

ELEVATOR BOLTS AND ACCESSORIES

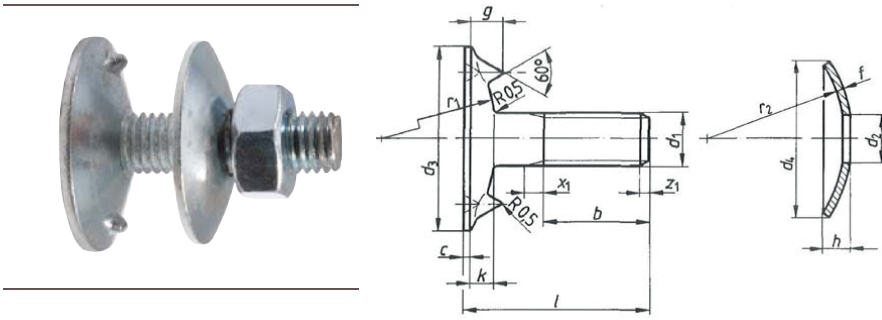

TECHNICAL SPECIFICATION - DIN 15237 ELEVATOR BOLTS

	Bolt head diameter	Allen key	Class	Weight (bolt only)	Packaging	Material	Material	Material
Dimensions (mm)	mm			gram	pcs.	zinc	carbon black	stainless steel
M6 x 25 small bolt head	Ø 18	optional	4.6	7,5	100	standard	optional	optional
M7 x 25	Ø 27	with and without	4.6	17,5	100	standard	optional	optional
M7 x 25 small bolt head	Ø 21	optional	4.6	10,5	100	standard	optional	standard
M8 x 25	Ø 30	with and without	4.6	19,5	100	standard	optional	optional
M8 x 25 small bolt head	Ø 24	optional	4.6	14,5	100	standard	optional	optional
M8 x 30	Ø 30	with and without	4.6	19,0	100	standard	optional	standard
M8 x 30 small bolt head	Ø 24	optional	4.6	16,5	100	standard	optional	optional
M8 x 35	Ø 30	with and without	4.6	21,5	100	standard	optional	standard
M8 x 35 small bolt head	Ø 24	optional	4.6	18,5	100	standard	optional	optional
M8 x 40	Ø 30	with and without	4.6	22,5	100	standard	optional	optional
M8 x 45	Ø 30	with and without	4.6	23,5	100	standard	optional	optional
M10 x 25	Ø 30	optional	4.6	31	100	standard	optional	optional
M10 x 30	Ø 30	with and without	4.6	37,5	100	standard	optional	standard
M10 x 35	Ø 30	with and without	4.6	38,5	100	standard	optional	standard
M10 x 40	Ø 30	with and without	4.6	39,5	100	standard	optional	standard
M10 x 45	Ø 30	with and without	4.6	40,5	100	standard	optional	standard
M10 x 50	Ø 30	with and without	4.6	43,5	100	standard	optional	optional
M10 x 55	Ø 30	with and without	4.6	46,5	100	standard	optional	optional
M12 x 45	Ø 42	with and without	4.6	68	100	standard	optional	optional
M12 x 50	Ø 42	with and without	4.6	70	100	standard	standard	optional
M12 x 55	Ø 42	with and without	4.6	73,5	100	standard	standard	optional
M12 x 60	Ø 42	with and without	4.6	83	100	standard	standard	optional
M12 x 65	Ø 42	with and without	4.6	92,5	100	standard	standard	optional
M12 x 70	Ø 42	with and without	4.6	102	100	standard	standard	optional

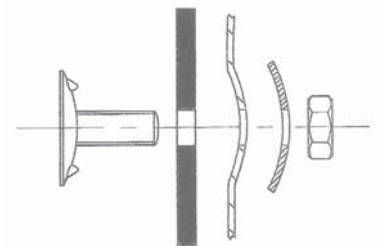

Elevator bucket installation with recessed elevator bucket bolt holes

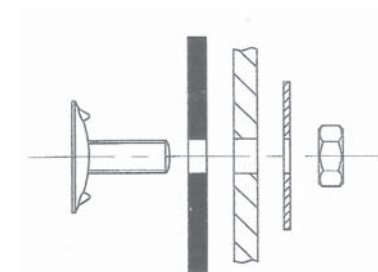

Elevator bucket installation with flat elevator bucket bolt holes

COMPONENTES FOR ELEVATORS

ELEVATOR BUCKET BOLTS

TECHNICAL SPECIFICATION - NORWAY STM (METRIC) ELEVATOR BOLT

	Bolt head diameter	Allen key	Class	Weight (bolt only)	Packaging	Material	Material	Material
								
Dimensions (mm)	mm			gram	pcs.	passivated	carbon black	stainless steel
M8 x 30	Ø 30	none		19,5	100	standard	optional	standard
M8 x 35	Ø 30	none		21,5	100	standard	optional	standard
M8 x 40	Ø 30	none		23	100	standard	optional	standard

ELEVATOR BOLTS AND ACCESSORIES

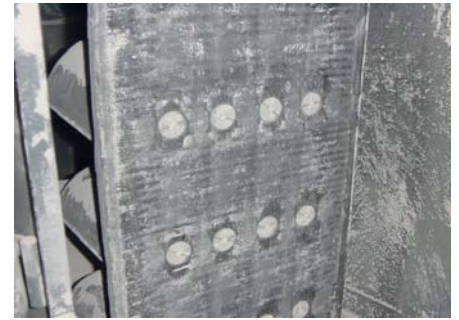

TECHNICAL SPECIFICATION - PTM ELEVATOR BOLT

	Bolt head diameter	Allen key	Class	Weight (bolt only)	Packaging	Material	Material	Material
								
Dimensions (mm)	mm			gram	pcs.	zinc	carbon black	stainless steel
M12 x 55	Ø 50	alleen met	10.9	76,0	100	optioneel	standaard	optioneel



PTM elevator bolt with Ø 50 mm bolt head and allen key

TECHNICAL SPECIFICATION - CONCAVE/DOMED WASHER

	s	d1	d2	Weight	Material	Material
						
Dimensions	mm	mm	mm	gram	zinc	stainless steel
M6	1,5	8,5	25	5,0	standard	standard
M7	1,5	8,5	25	5,0	standard	standard
M8	1,5	9,0	32	7,0	standard	standard
M10	2,0	12,0	41	15,5	standard	standard
M12	2,0	14,0	51	31,0	standard	standard

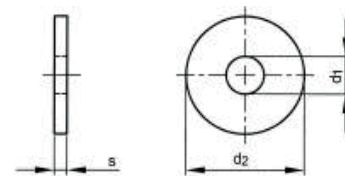

TECHNICAL SPECIFICATION - FLAT WASHER DIN9021

	s	d1	d2	Weight	Materiaal	Material
						
Dimensions	mm	mm	mm	gram	zinc	stainless steel
M6	1,9	7,5	21,5	5,0	standard	standard
M7	1,9	7,5	21,5	5,0	standard	standard
M8	2,0	8,5	23	6,0	standard	standard
M10	2,1	10,8	29,5	11,0	standard	standard
M12	2,5	13,0	36,5	19,0	standard	standard

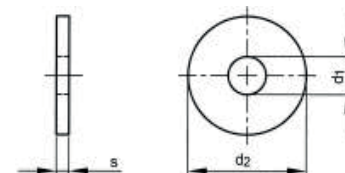

TECHNICAL SPECIFICATION - HEXAGON NUT DIN 934

	m	d	s	Weight	Material	Material
						
Dimensions	mm	mm	mm	gram	zinc	stainless steel
M6	5,0	5,0	10,0	3,0	standard	standard
M7	5,0	6,0	11,0	3,0	standard	standard
M8	6,5	7,0	13,0	5,0	standard	standard
M10	8,0	9,0	17,0	11,0	standard	standard
M12	10,0	11,0	19,0	16,0	standard	standard

ELEVATOR BOLTS AND ACCESSORIES

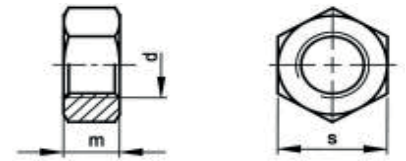

DIN15237 elevator bolt with allen key

TECHNICAL SPECIFICATION - NYLOCK NUT DIN 985

	h	d	s	Weight	Material	Material
						
Dimensions	mm	mm	mm	gram	zinc	stainless steel
M6	6,0	5,0	10,0	3,0	standard	standard
M7	7,5	5,0	11,0	3,0	standard	standard
M8	8,0	7,0	13,0	5,0	standard	standard
M10	9,8	9,0	17,0	11,0	standard	standard
M12	11,9	11,0	19,0	16,0	standard	standard

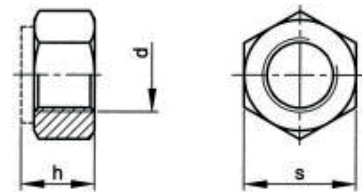

TECHNICAL SPECIFICATION - HEAT RESISTANT LOCK NUT DIN 980V

	h	d	s	Weight	Material	Material
						
Dimensions	mm	mm	mm	gram	zinc	stainless steel
M6	6,0	5,0	10,0	5,0	standard	standard
M7	7,5	6,0	11,0	5,0	standard	standard
M8	8,0	7,0	13,0	7,0	standard	standard
M10	9,8	9,0	17,0	13,0	standard	standard
M12	11,9	11,0	19,0	18,0	standard	standard

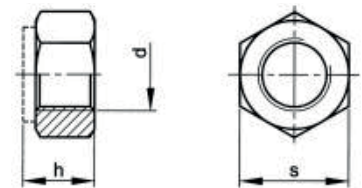

- The elevator bucket bolts en accessories as mentioned in this technical datasheet are our standard dimensions and materials available from stock. Non-standard dimensions en materials are available on request.
- Please contact your Muller Beltex representative to advise you on the correct bucket to belt attachment.