

Coaxial Gearmotor & Gear Unit

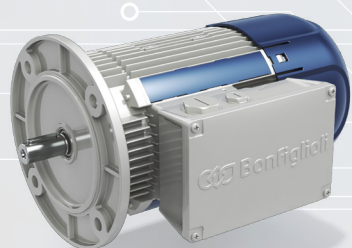

Asynchronous Motor

eVOX Platform

Product Catalog



PRODUCTS &
SOLUTIONS



Summary



Configuration Guidelines	2	Configuration	59
Environmental Conditions.....	3	Duty Cycle.....	59
Lubricant Tables.....	5	Ambient temperature and altitude	60
Product Selection Guidelines	6	Product Modularity.....	61
Application Inputs.....	6	Designation.....	62
Gear Unit Selection.....	8	Voltage/Frequency.....	63
Verification.....	10	Nameplate.....	64
EVOX Coaxial Gearmotor & Gear Unit	12	Protection class.....	65
Product Overview.....	13	Insulation class.....	66
Technical Features.....	14	Versions	67
Suitable applications	16	Performance	68
Configuration.....	18	EVOX E-Motor.....	68
Product Modularity.....	18	Brake EVOX Electric Motor	72
Designation.....	20	Product Overview.....	72
Versions	22	Designation.....	73
Mounting Positions.....	23	Performance	75
Performances	25	Options Brake.....	78
EVOX Coaxial Gearmotor	25	Options EVOX Electric Motor Side.....	86
EVOX Coaxial Gear Unit.....	37	Option List	86
Dimension	42	Dimensions.....	94
EVOX Coaxial Gearmotor	42	EVOX Electric Motor.....	94
EVOX Coaxial Gear Unit.....	43	Brake and E-motor options.....	95
Option EVOX Coaxial Gear Unit Side.....	44	Order info.....	96
Option List.....	44	Research & Development.....	97
Option List Deep Dive.....	46	Global Presence.....	98
EVOX Electric Motor	53		
Product Overview.....	54		
Bonfiglioli Portfolio.....	54		
Standards & Directives.....	58		

Configuration Guidelines



Environmental Conditions

Ambient Temperature

The ambient temperature influences the gearbox and motor performance (for derating data due to the motor ambient temperature, see the catalog section: [e-motor Configuration Guidelines & Setup](#)).

Please take into account the following guidelines for a correct product configuration:

- **Oil Seals:** please see the Oil seal options in each Gear Unit Section and select the correct alternative according to the operating conditions.
- **Lubricant:** if the operating temperature is outside the indicated range for the standard lubricant, please select SO to order the Gear Unit without oil and then refer to the [Lubricant table](#) to select the correct lubricant for your operating temperature range.
- **Housing and component resistance:** if the operating temperature is below -25°C, or above 50°C, please [contact Bonfiglioli Technical Service](#). From -25°C to -10°C, please start the gearmotor with partial loads.
- **Motor stator:** in case of special humidity and ambient temperature resistance requirements, please see the motor tropicalization option.

To allow a proper heat dissipation, make sure the product is installed with adequate air circulation, away from temperature-sensitive components.

For altitude < 3000m and environment temperature <50°C, these Gear Units thermal power is not a possible cause of fault. If the Gear Unit environment exceeds these limits, please [contact Bonfiglioli Technical Service](#).

Altitude

The installation altitude affects the gear unit and motor performance (for motor temperature derating data, see the [e-motor Configuration Guidelines & Setup](#) Catalog Section).

If the application altitude is above 1500 m and the gear unit is oil factory filled, place the product with the oil drain plug at the top and open it to balance out the internal air and the external atmosphere, then close the oil plug. Make sure that no object or substance falls into the gear unit, as it could damage its internal components during its operating lifetime.

If, during its lifetime, the gear unit operates with a difference of altitude higher than 1000 m, [contact Bonfiglioli Technical Service](#) to find the correct solution, based on the required performance, the seals equipped and the mounting position needed.

Noise Level

Gear unit noise levels tested according to UNI ISO 3746. The noise of the gear unit is always lower than the motor's, which is compliant with the CEI EN 60034-9 standard.

Environmental Conditions

Corrosion Protection

The gear unit and motors can be configured with several devices to enhance their protection against corrosion, see EVOX Painting Options against corrosion protection and FO option to add stainless steel components to your product.

Storage

See the Product Storage Guidelines on the EVOX user manual at www.bonfiglioli.com for a thorough description of every environment and treatment conditions (for less and more than 6 storage months).

Observe the following instructions to correctly store the products:

- a) Do not store outdoors, in areas exposed to the weather or with excessive humidity.
- b) Always place boards, wood or other materials between the products and the floor.

The gearboxes should not have direct contact with the floor.

- c) In case of long-term storage, all machined surfaces such as flanges, shafts and couplings must be coated with a suitable rust inhibiting product (Mobilarma 248 or equivalent).

In addition, the gear units must be placed with the fill plug in the highest position and filled up with oil.

Before putting the units into operation, top-up with the appropriate quantity and type of oil (refer to the User's manual available at www.bonfiglioli.com).

Gear Unit Efficiency

For Helical In-Line Gear units, consider as a general order of magnitude $0,98^{N_{st}}$ [N_{st} = stage number], for an efficient calculation.

Lubricant Table

Life lubricated gear units do not require any periodical oil changes.

Refer to the User's Manual available at www.bonfiglioli.com for indications regarding oil checks and replacement.

Do not mix synthetic and mineral oils and/or different brands.

In any case, check the oil level at regular intervals and top it up as required.

Check it monthly, if the unit operates under intermittent duty, or more frequently if duty is continuous.

As standard, factory-filled gear units are equipped with Shell Omala S4 WE320 (PAG).

Do not let the oil temperature drop below the pour point -39°C or rise above 100°C also in storage conditions.

The gear unit can be filled with different oils, according to the application needs. You can choose the gear unit SO option and fill the EVOX with one of the oils listed in the following table.

		Operating ambient temperature [C°]																					
		-40	-35	-30	-25	-20	-15	-10	-5	0	+5	+10	+15	+20	+25	+30	+35	+40	+45	+50			
		Seals conditions check			Standard seals provided in the catalog																		
Splash lubrication	Mineral oil	150 VG						*															
		220 VG	⊘						*													⚙	
		320 VG	⊘							*													⚙
		460 VG									*												⚙
	Synthetic oil (PAG)	150 VG				*																⚙	
		220 VG	⊘				*																⚙
		320 VG	⊘				*																⚙
	Synthetic oil (PAO)	32 VG	*																				⚙
		68 VG		*																			⚙
		150 VG	⊘		*																		⚙
		220 VG	⊘			*																	⚙
		320 VG					*																⚙

□ Recommended operating limits

⋯ Allowed operating limits. ⚙

⊘ Forbidden operating limits.

* = It is recommended to ramp-up and provide for greater absorption of the motor.

⚙ If needed, and in the event of impulse loads, contact Bonfiglioli Technical Service.

ATTENTION

Bonfiglioli's factory filled gear units shouldn't be operated outside the temperature range indicated in this catalog.

Bonfiglioli shall not be liable for use of lubricants outside the suggested temperature range or mix of different lubricant types or manufacturers.

Oils with the same viscosity and different brands may have different characteristics in terms of operating temperature ranges. The table above is a general guideline; however, you should always check the oil specifications before filling and using EVOX gear units.

The oil quantity for each gear unit size is:

Size	Volume (L)
07	0.35
17	0.7
37	1.1
47	1.8

Product Selection Guidelines

In order to correctly choose the product that fits your needs, please refer to the Application Input parameters listed below, choose the configuration in the performance table, then verify your EVOX with the [Verification parameters](#).

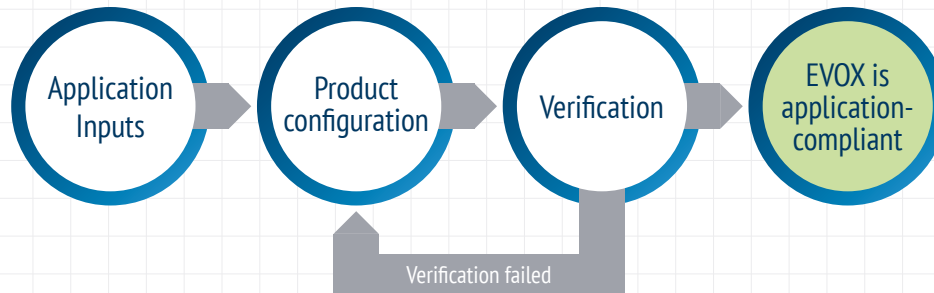

Application Inputs

Some fundamental data are necessary to assist the correct selection of a gearbox or gearmotor. The table below briefly sums up this information.

To simplify selection, fill in the table and send a copy to our [Bonfiglioli Technical Service](#) which will select the most suitable drive unit for your application.

Type of application	A_{c2} Thrust load on output shaft (+/-) (***)	N
P_{r2} Output power at n_2 max	A_{c1} Thrust load on input shaft (+/-) (***)	N
P_{r2}' Output power at n_2 min	J_c Moment of inertia of the load	Kgm ²
M_{r2} Output torque at n_2 max	t_a Ambient temperature	C°
n_2 Max.output speed	Altitude above sea level	m
n_2' Min.output speed	Duty type to IEC norms S...../.....%	
n_1 Max.input speed	Z Starting frequency	1/h
n_1' Min.input speed	Motor voltage	V
R_{c2} Radial load on output shaft	Brake voltage	V
x_2 Load application distance (*)	Frequency	Hz
Load orientation at output	M_b Brake torque	Nm
Output shaft rotation direction (CW-CCW) (**)	Motor protection degree IP.....	
R_{c1} Radial load on input shaft	Insulation class	
x_1 Load application distance (*)		
Load orientation at input		
Input shaft rotation direction (CW-CCW) (**)		

(*) Distance x1-2 is between force application point and shaft shoulder (if not indicated the force acting at mid-point of the shaft extension will be considered).

(**) CW = clockwise; CCW = counterclockwise

(***) + = push; - = pull

Application Service Factor

The service factor [f_s] is the ratio between the Nominal Table Torque [M_2] and the Calculated Torque [M_{c2}] needed by your Application.

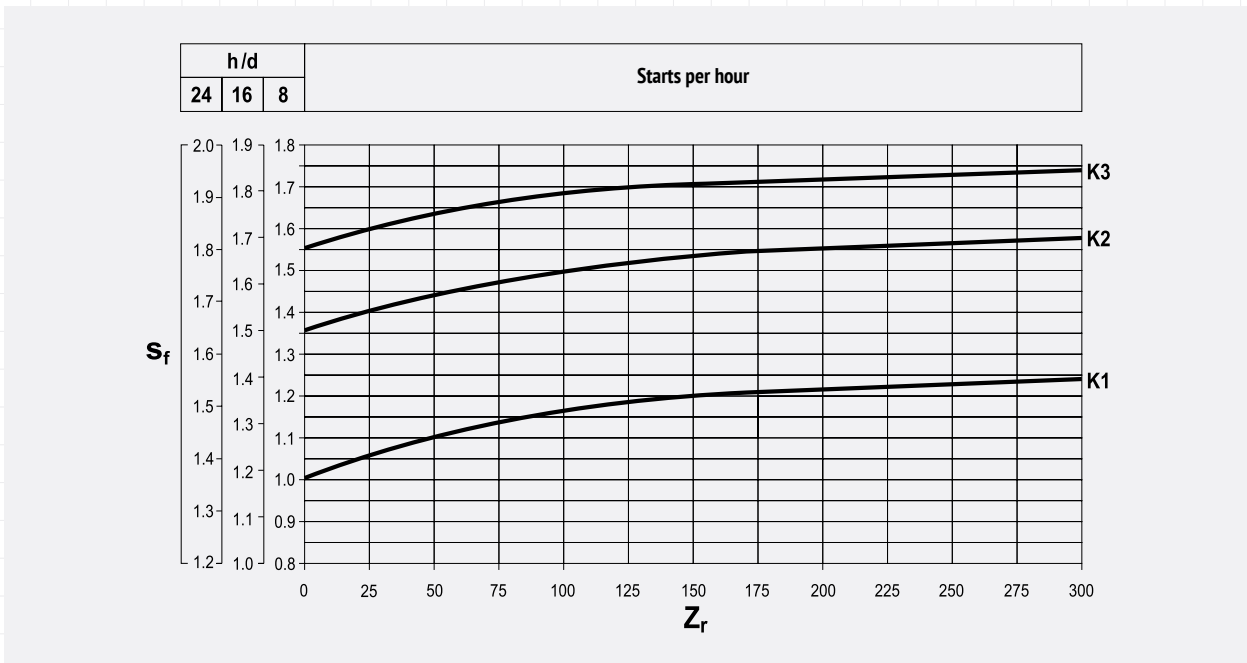

The [f_s] calculation depends on 3 factors in the previous diagram:

- **Startup frequency [Z_r]**: this parameter describes the Gear Unit start-ups per hour
- **Daily work hours**: this parameter selects the y axis where you can check your service factor [f_s]
- **Mass acceleration factor [K_x]**: this parameter describes the shock loads of your application on the Gear Unit and drives the f_s curve selection

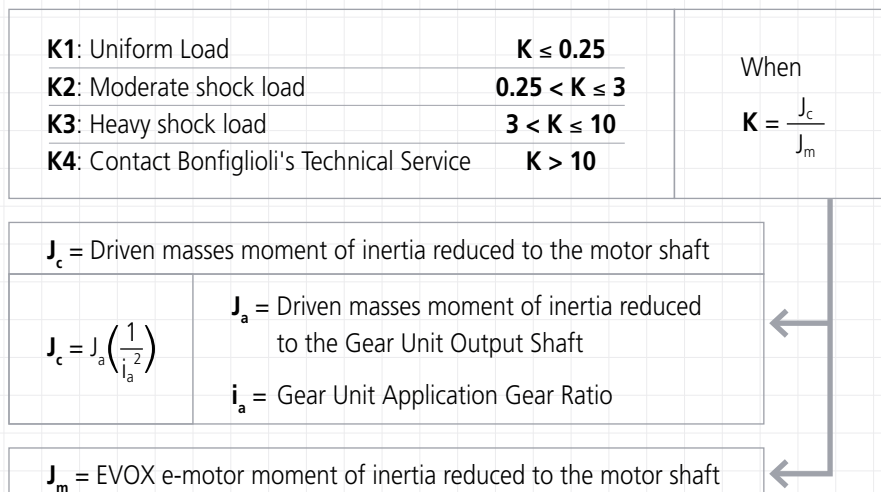

Product Selection Guidelines

Gear Unit Selection

Gear Unit Configuration

- Determine service factor [f_s] according to type of duty (factor K), number of starts per hour [Z_s] and hours of operation.
- From values of torque [M_{r2}], speed [n_2] and efficiency [η_d] the required input power can be calculated from the equation:

$$P_{r1} = \frac{M_{r2} \cdot n_2}{9550 \cdot \eta_d} \text{ [kW]}$$

Value of [η_d] for the captioned gear unit can be sorted out from [Gear Unit Efficiency paragraph](#).

- Consult the gearmotor selection charts and locate the table corresponding to normalised power [P_n]:

$$P_n \geq P_{r1}$$

Unless otherwise specified, power [P_n] of motors indicated in the catalogue refers to continuous duty S1. For motors used in conditions other than S1, the type of duty required by reference to CEI 2-3/IEC 34-1 Standards must be mentioned.

For duties from S2 to S8 in particular and for motor frame 132 or smaller, extra power output can be obtained with respect to continuous duty see the [e-motor Configuration Guidelines & Setup](#) catalog section

Accordingly the following condition must be satisfied:

$$P_n \geq \frac{P_{r1}}{f_m}$$

The adjusting factor [f_m] can be obtained from table above.

Intermittence ratio

$$I = \frac{t_f}{t_f + t_r} \cdot 100$$

t_f = work time at constant load
 t_r = rest time

	Duty						S4 - S8
	S2			S3*			
	Cycle duration [min]			Cycle duration factor [I]			
	10	30	60	25%	40%	60%	Please contact us
f_m	1.35	1.15	1.05	1.25	1.15	1.1	

* Cycle duration, in any event, must be 10 minutes or less. If it is longer, please [contact Bonfiglioli Technical Service](#)

Next, refer to the appropriate [P_n] section within the gearmotor selection charts and locate the unit that features the desired output speed [n_2], or closest to, along with a safety factor S that meets or exceeds the applicable service factor [f_s].

The safety factor is so defined:

$$S = \frac{M_{n2}}{M_2} = \frac{P_{n1}}{P_1}$$

Selection of speed reducer and gearbox with IEC motor adapter

- a) Determine service factor [f_s].
- b) Assuming the required output torque for the application [M_{r2}] is known, the calculation torque can be then defined as:

$$M_{c2} = M_{r2} \cdot f_s$$

- c) The gear ratio is calculated according to requested output speed [n_2] and drive speed [n_1]:

$$i = \frac{n_1}{n_2}$$

Once values for [M_{c2}] and [i] are known consult the rating charts under the appropriate input speed [n_1] and locate the gear unit that features the gear ratio closest to [i] and at same time offers a rated torque value [M_{n2}] so that:

$$M_{n2} \geq M_{c2}$$

If a IEC normalized motor must be fitted check geometrical compatibility with the gear unit in [Gear Units Performance tables](#).

Product Selection Guidelines

Verification

The maximum torque (intended as instantaneous peak load) applicable to the gearbox must not, in general, exceed 200% of rated torque [M_{n2}]. Therefore, check that this limit is not exceeded, using suitable torque limiting devices, if necessary.

After the selection of the speed reducer, or gearmotor, is complete it is recommended that the following verifications are conducted:

Thermal capacity

For altitude < 3000m and environment temperature < 50°C, these Gear Units thermal power is not a possible cause of fault. If the Gear Unit environment exceeds these limits, please [contact Bonfiglioli Technical Service](#).

To allow a proper heat dissipation, make sure the product is installed with adequate air circulation, away from temperaturesensitive components.

Load Conditions on Gear Unit Shafts

Radial loads have to be lower than the one shown in the [Catalog Performances Table](#).

Radial loads in the performance tables are the calculated at the worst condition on your Gear Unit:

- Nominal torque applied on output shaft
- Worst Gear Unit rotating direction [CW or CCW]
- The radial force applied with the worst calculated angle α for each gear ratio

The permitted radial loads can increase considerably when the parameters listed above vary. [contact Bonfiglioli technical Service](#) if the application requires radial loads higher than the values indicated in the tables, because they may be reachable with a standard Gear Unit or with a simple option instead of a tailored solution.

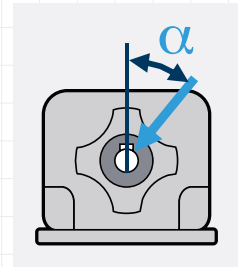



External Load Calculation on Gear Unit Shafts

External transmission could generate loads on the Gear Unit shafts.

The guidelines below are used to calculate the radial load.

This is a very simplified method to get the order of magnitude of the radial loads on the Gear Unit shafts. We recommend you follow more detailed considerations on your application to select the correct EVOX Gear Unit.

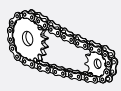
$$R_c = \frac{2000 \cdot M_a \cdot K_r}{d}$$

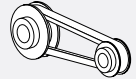
$K_r = 1$	
$K_r = 1.25$	
$K_r = 1.5 - 2.0$	

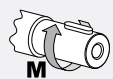
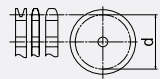
M_a [Nm]	
d [mm]	

Position of the Force Radial Component on the Gear Unit Shafts

Radial loads in performance tables are considered in the middle of the shaft.

If you want to compare them with the $[R_c]$ needed, you have to convert value $[R_{max}]$ in the performance tables with the following formula, to obtain the same stress on the bearing, considering a $[R_{max}]$ application straight shifting, in superposition with the $[R_c]$.

$$R_a = R_{max} \frac{l_1}{l_2 + x}$$

The following formula needs to be verified:

$$R_a > R_c$$

Check values $[l_1]$ and $[l_2]$ in the following tables:

Coaxial Gear Unit Output Shaft								
Size	l1	l2	ds	ls	l1	l2	ds	ls
	[mm]				[in]			
07	87	67	20	40	3.425	2.638	3/4	1-9/16
17	97.75	77.75	20	40	3.848	3.061	3/4	1-9/16
37	118	93	25	50	4.646	3.661	1	2
47	130.2	100.2	30	60	5.126	3.945	1-1/4	2-3/8

Solid input shaft				
Size	l1	l2	ds	ls
	[mm]			
HS1	97	77	16	40
HS2	81	61	19	40
HS3	117.5	92.5	24	50
	[in]			
NHS1	3.819	3.032	5/8	1-9/16
NHS2	3.189	2.402	3/4	1-9/16
NHS3	4.626	3.642	7/8	2

Axial Load on Shafts

On both input and output shafts, consider 50% of the max radial load in the Performance Tables as an axial load limit, if there isn't a radial force component on the shaft.

If the force on the output shaft has both radial and axial components, [contact Bonfiglioli technical Service](#) and check if your solution is suitable.

EVOX
Coaxial Gearmotor
& Gear Unit



Product Overview



EVOX is Bonfiglioli's new geared motor platform; the EVOX family starts with the new **CP**.

EVOX CP is an helical in-line product designed with a smooth surface and a performance/value focus.

Its footprint aligned with market standards allows fitting your machine without changing the gear unit interface. Thanks to the wide range of versions/options and motor technology available in **Bonfiglioli's portfolio**, this new product can be adapted to any machine need.

Features	Benefits
Market standard footprint	Fits easily on every machine interface
Smooth surface	Easy-clean shape
Every mounting position available with the standard Product	Lower stock codes
High torque density for in-line technology	High roughness and performances
Reinforced radial/axial bearing option	Product ready for decentralized transmission
Feet & flange output & high speed ratios	Product ready for pumps & compressors

EVOX CP sizes	Nominal torque	Gear ratio range	Max radial loads	Max Compact Gearmotor Power	
	[Nm]		[N] ¹	[kW]	[hp]
07	55	2.8-81.2	1600	0.37	0.5
17	100	2.4-85.9	1770	0.75	1
37	200	2.3-133	4500	up to 1.5kW; Higher Powers are Coming Soon	up to 2hp; Higher Powers are Coming Soon
47	335	2.4-172	5000		
57	500				
67	650				

(1) Max performances @ 1400 rpm in input, Nominal output torque and radial load, applied in the middle of the o. shaft.
This value could change with the gear ratio

Product Overview

Technical Features

Gear Unit – Coaxial CP

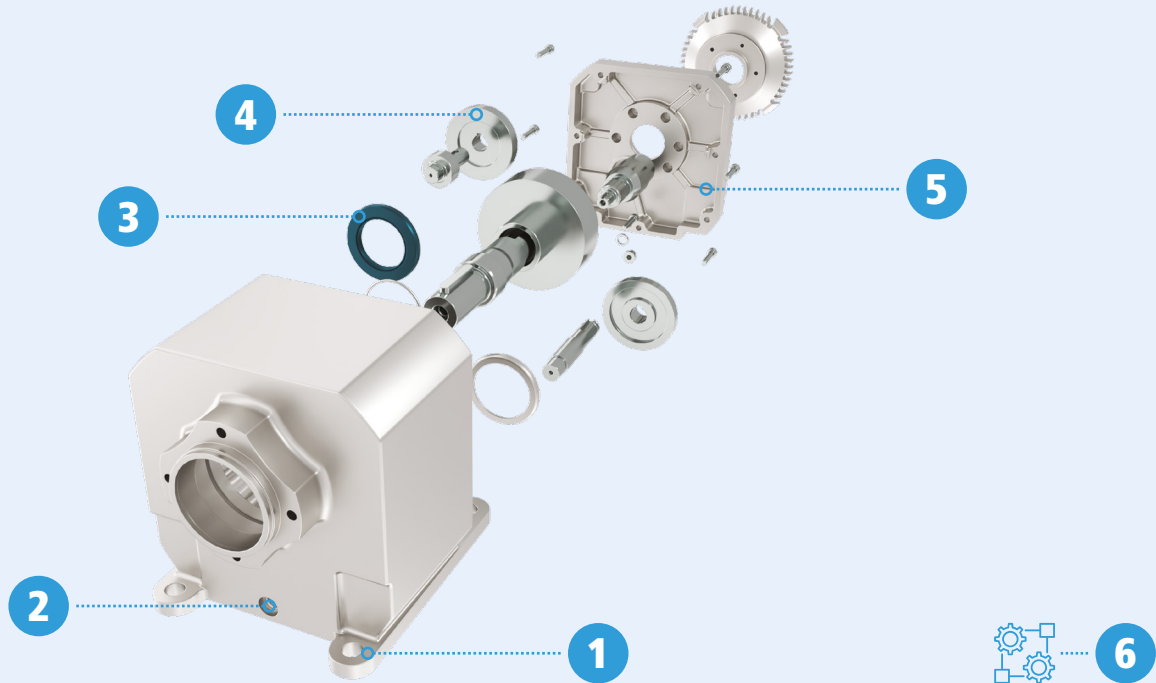

1 MKT standard footprint

2 Every mounting position possible with one product

With its unique oil level, this gear unit can be fitted on any position. This also means less plugs and leakages.

3 Reliability focus for every standard component

Using more reliable components improves the reliability of the whole product.

4 Efficiency and low noise gears set

These highly effective gears reduce oil heating, preventing its leakage through the seals.

5 Product flexibility/modularity

Easy assembly with simple tools.

6 Great set of versions and options

Electric Motor – MXN/MNN

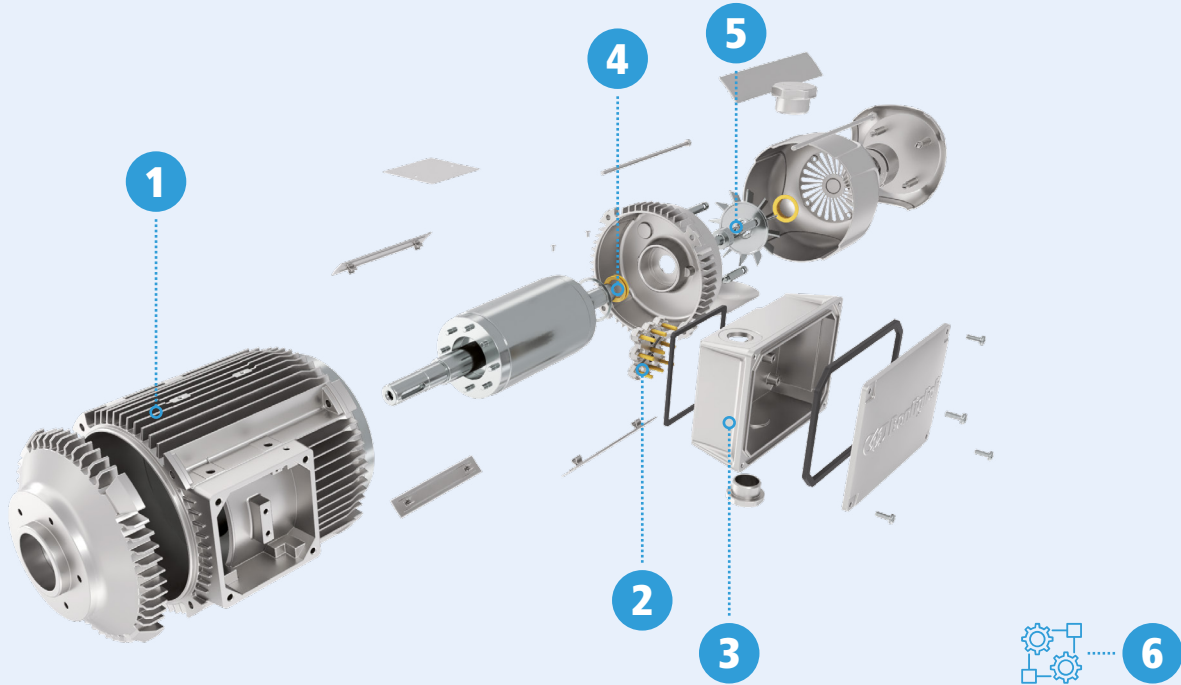

1 Uncompromised IE3/NEMA Premium Efficiency

This motor is compliant with the most severe regulations in the world in terms of efficiency.

2 One motor for EU, USA, India & Australia

With its particular 9 PIN connection, by simply changing the plugs arrangement, you could get the right tension for most Countries as Standard.

3 Reliability focus for every standard component

Using more reliable components improves the reliability of the whole product.

4 Rotating terminal box

With this feature, you could rotate the terminal box in every position you need.

5 Modular brakes, encoders and fans

6 Great set of versions and options

Product Overview

Suitable applications

- **Product fully interchangeable with MKT standard**
- **IE3/NEMA Premium uncompromised efficiency**
Making it technically ready for premium efficiency applications worldwide.

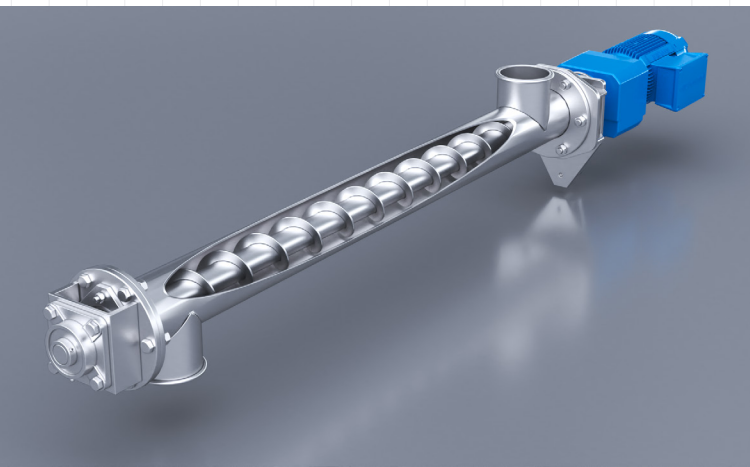

High axial & radial loads options

Making this product suitable for screw conveyors and/or decentralized transmissions.



Compact design

Making it compatible even with severe application constraints.

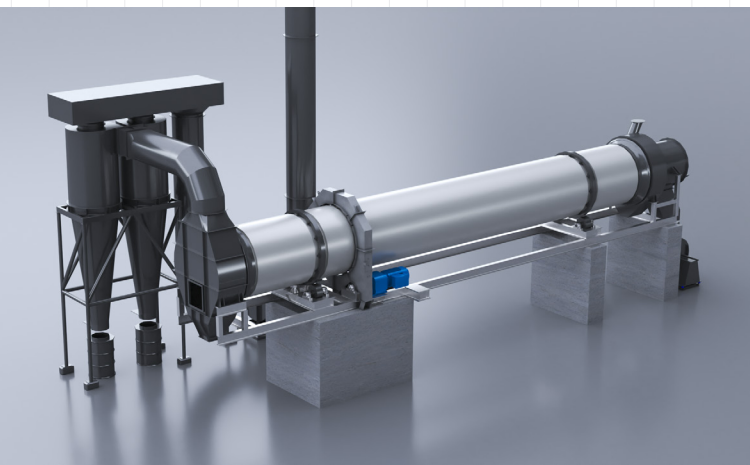

MKT best in class by torque

Making the product with the highest torque density of its category.



**AUTOMATIC GATES
& BARRIERS**



RECYCLING



TEXTILE



**FOOD &
BEVERAGE**



PACKAGING



**HEATING, VENTILATION
& AIR CONDITIONING**



**MATERIAL
HANDLING**



Configuration

Product Modularity

Gear Unit – Coaxial CP



These gear unit solutions can meet **all** basic **MKT needs**.
Soon to be followed by several other products.

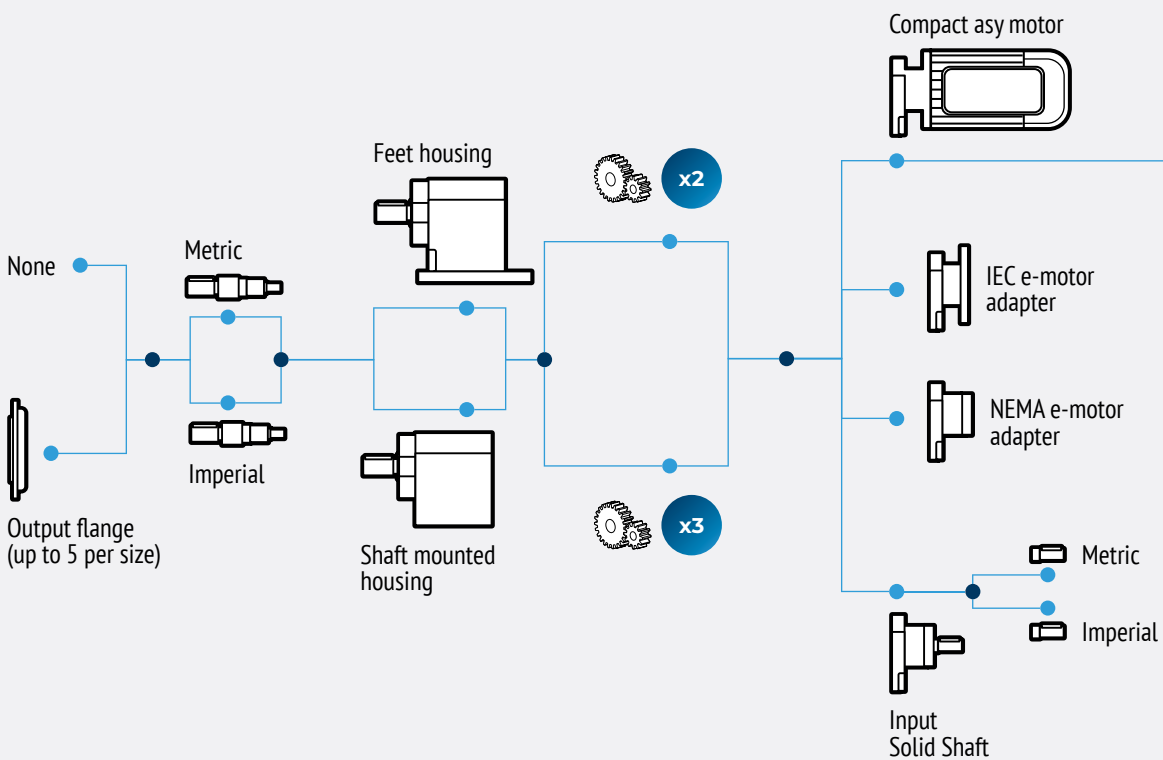

Electric Motor – MXN/MNN



Lots of e-motor versions available to perfectly match your application needs.

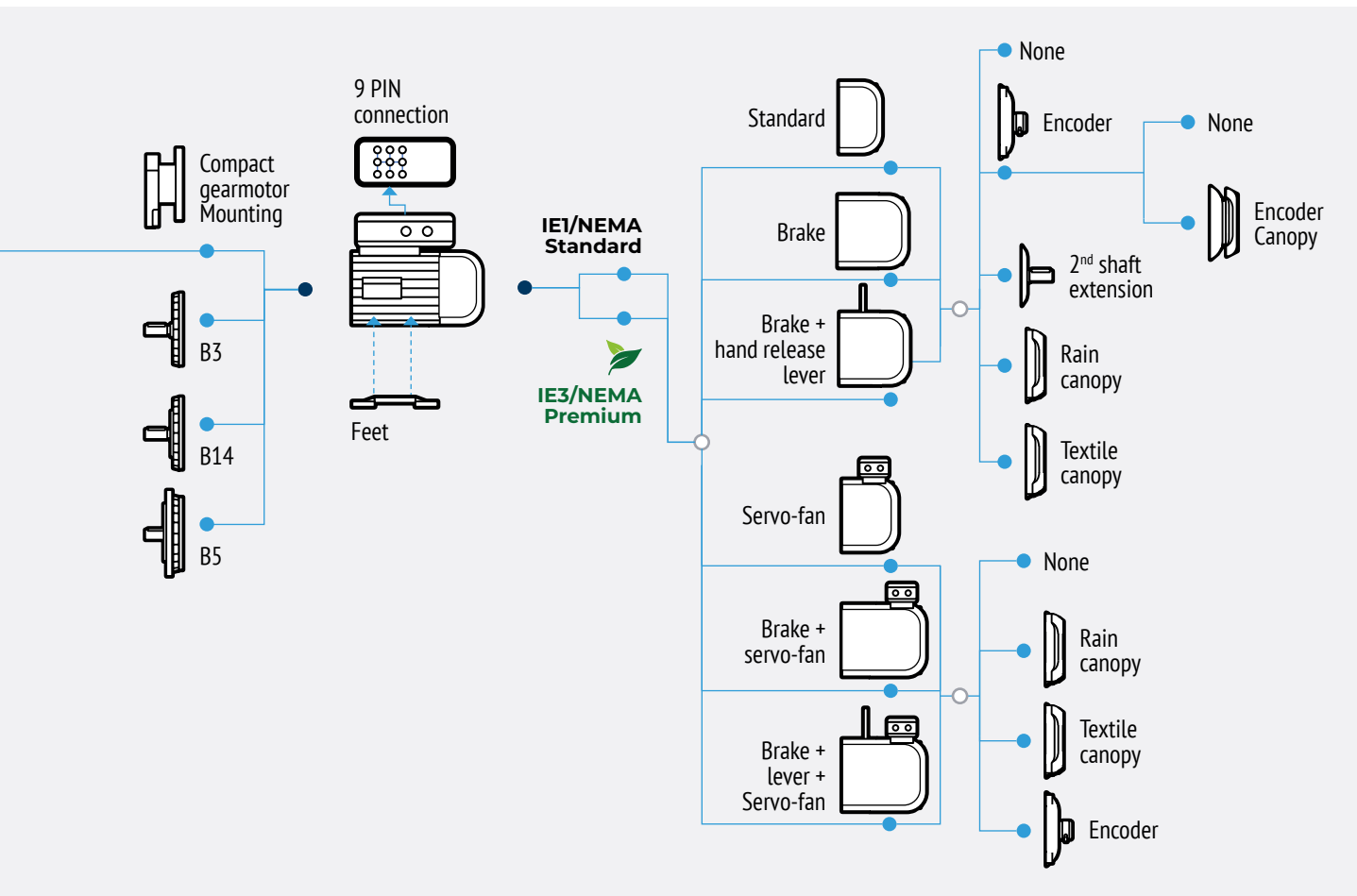

AC and DC brake are available.

Configuration

Designation

Gear Unit – Coaxial CP

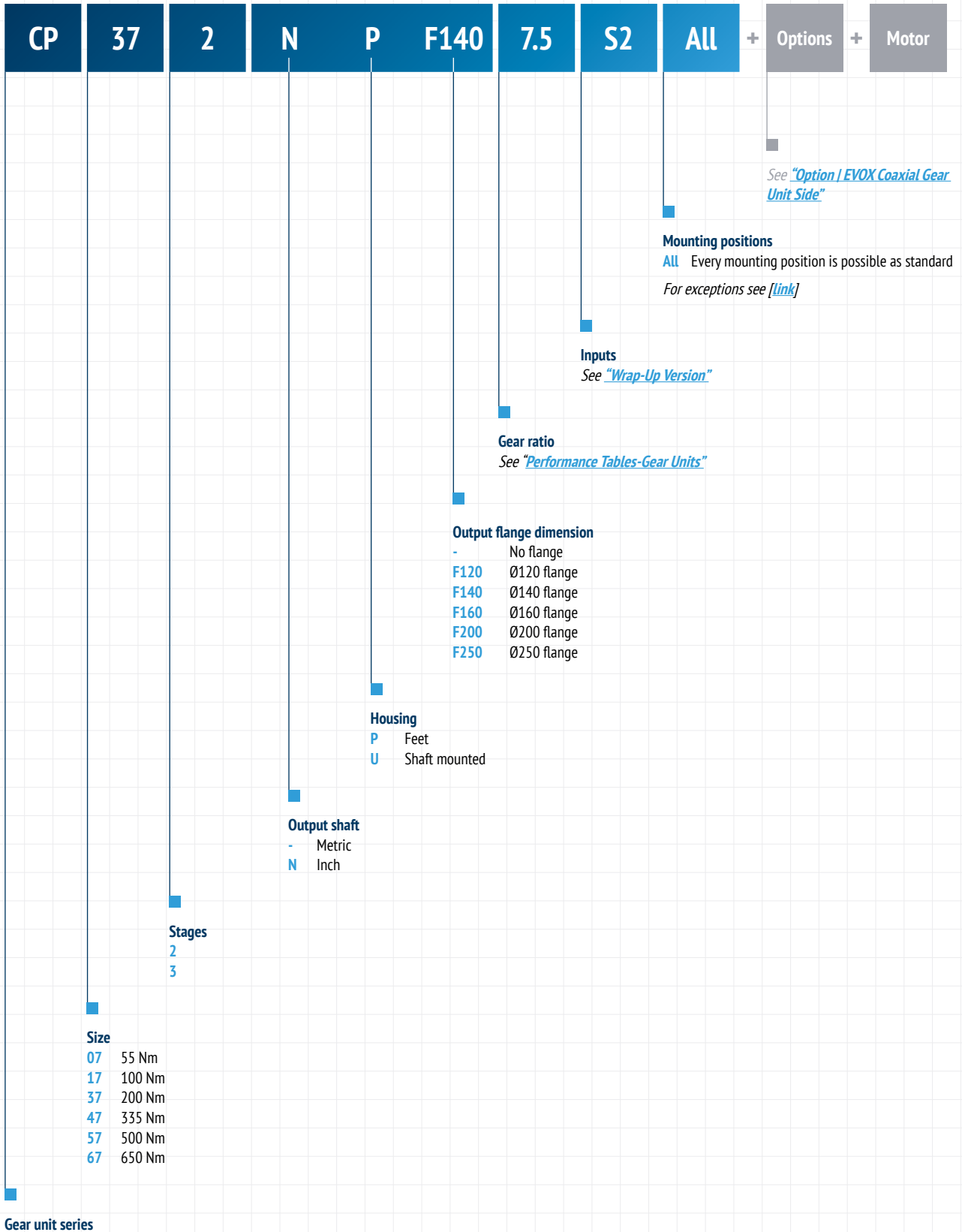

Electric Motor – MXN/MNN

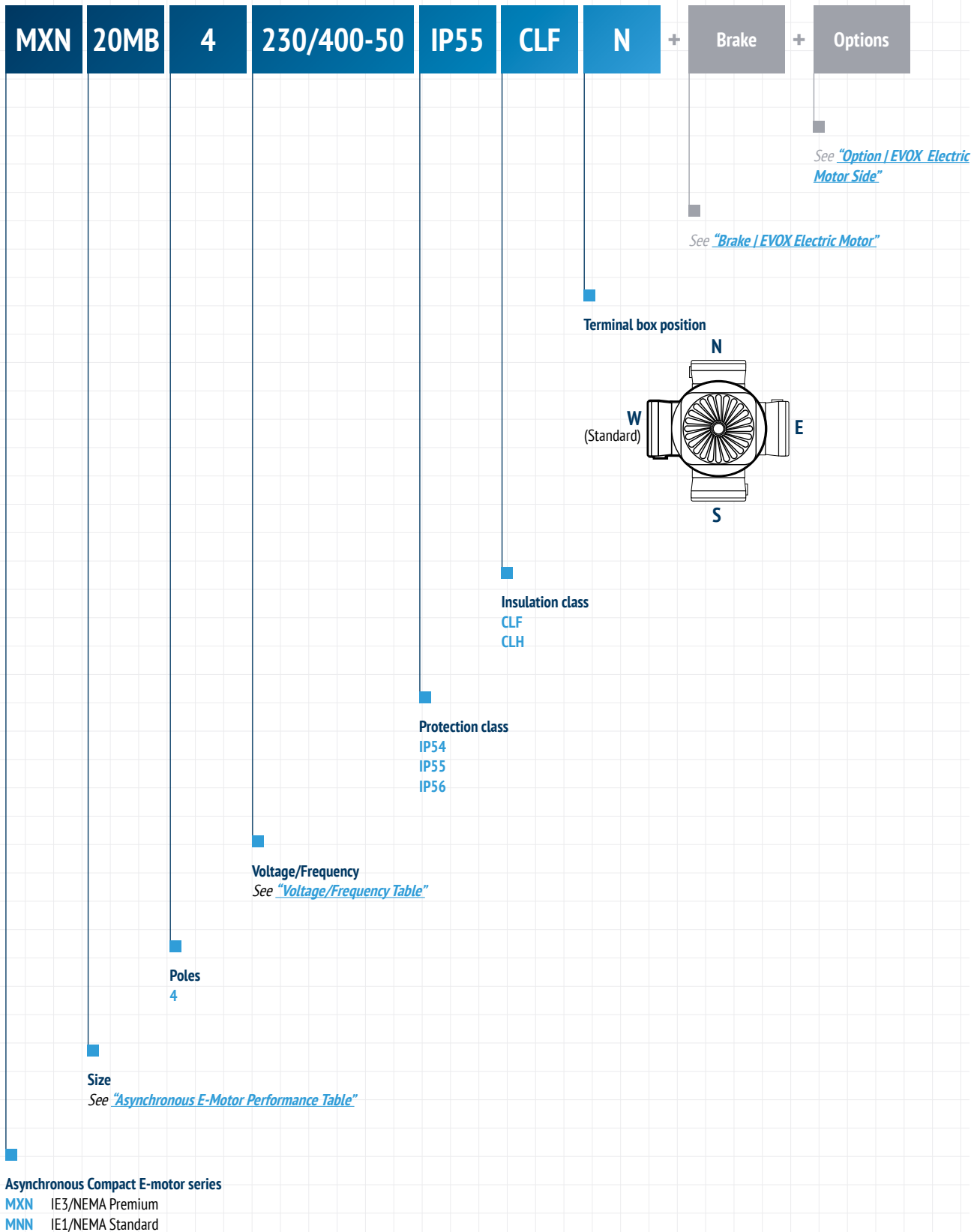

Configuration

Versions

Gear Unit – Coaxial CP

Input table

Input type	Sizes								
	P56	P63	P71	P80	P90	P100	P112	P132	
IEC motor adapter	P56	P63	P71	P80	P90	P100	P112	P132	
Compact motor adapters	-	S05	S10	S20	S25	Coming Soon			
Solid Shaft	HS1			HS2		HS3			
NEMA motor adapter			N56	N143	N145	N182	N184	N213	N215
CP07									
CP17		X							
CP37		X		X					
CP47				X		X			
CP57	Coming Soon								
CP67	Coming Soon								

 IEC and NEMA input coupling available

 Solid input shaft coupling available

Output flange table

	Sizes				
	F120	F140	F160	F200	F250
CP07	X				
CP17	X	X	X		
CP37	X	X	X	X	X
CP47		X	X	X	X
CP57	Coming Soon				
CP67	Coming Soon				

 Output flange compatible

 PF feet and flange version availability

Mounting Positions

Gear Unit – Coaxial CP

Every mounting position possible with one code

Thanks to the enhanced performances and the reliability of standards components, this gear unit can be mounted in every mounting position possible as standard.

The EVOX CP is supplied as standard with long life oil fill and a unique oil level for each mounting position; if the SO option is selected, the Gear Unit can be filled with a unique drain/fill plug between the feet.

This feature can boost your project flexibility and allow you to fit this product in positions that couldn't be reached without a tailored solution.

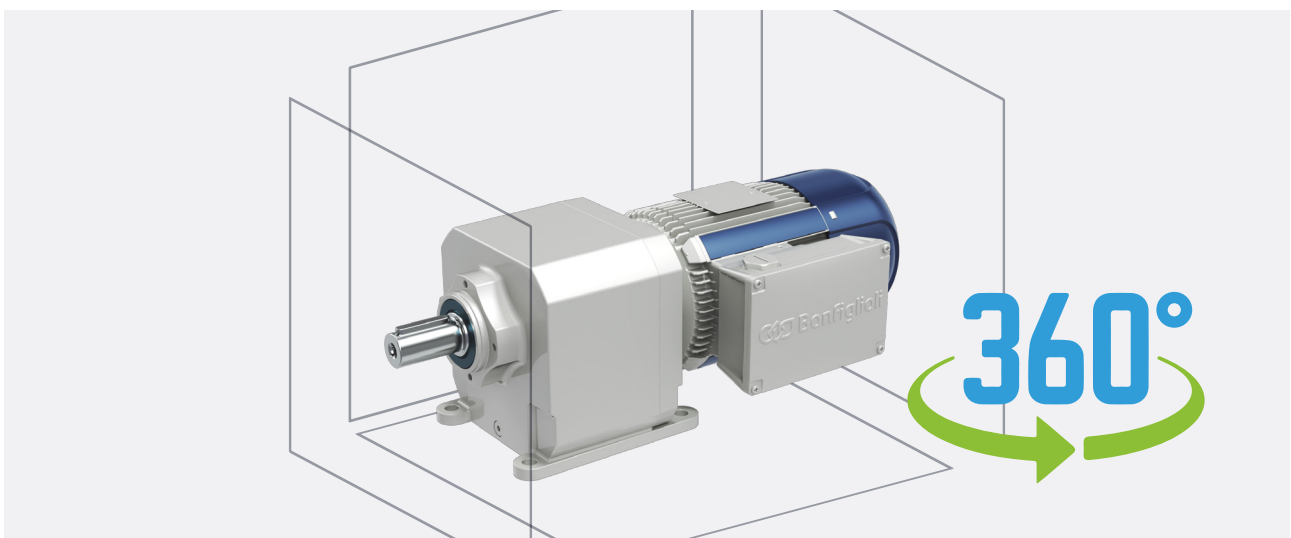

Mounting position limitations

Reinforced output bearings option [OHA - OHR]

If you need EVOX CP with both:

- OHR or OHA
- Vertical position with the output shaft on top, or a position within 60° from it, facing any direction,

[Contact Bonfiglioli's Technical Service](#) and check if the standard oil level is correct for your application, or if you require a tailored solution.

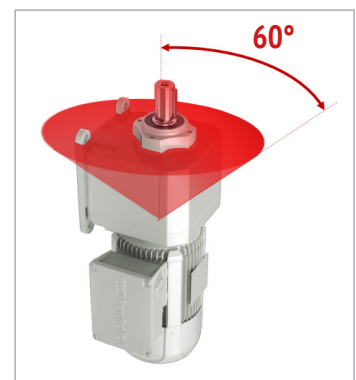

Explosion-proof Gear Unit option [EX]

If the gear unit is equipped with the EX option, only 6 mounting positions are available (check these positions in the Gear Unit Options Catalog section). The unique oil level allows you to fit EVOX CP in any of the 6 standard positions with a single product code; however, any degree variation in both directions should be avoided, to observe the oil check plug position. Refer to the user manual at www.bonfiglioli.com for compliant maintenance procedures.

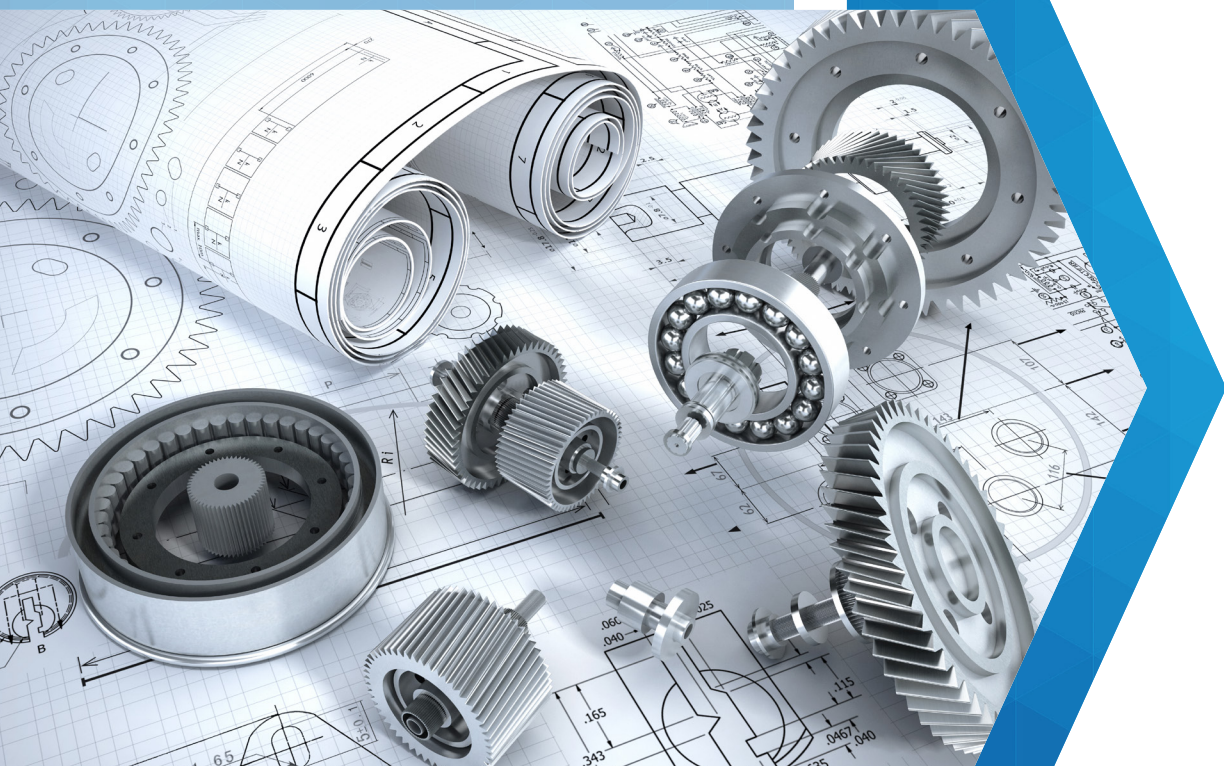

Performances

EVOX Coaxial Gearmotor

Tables introduction

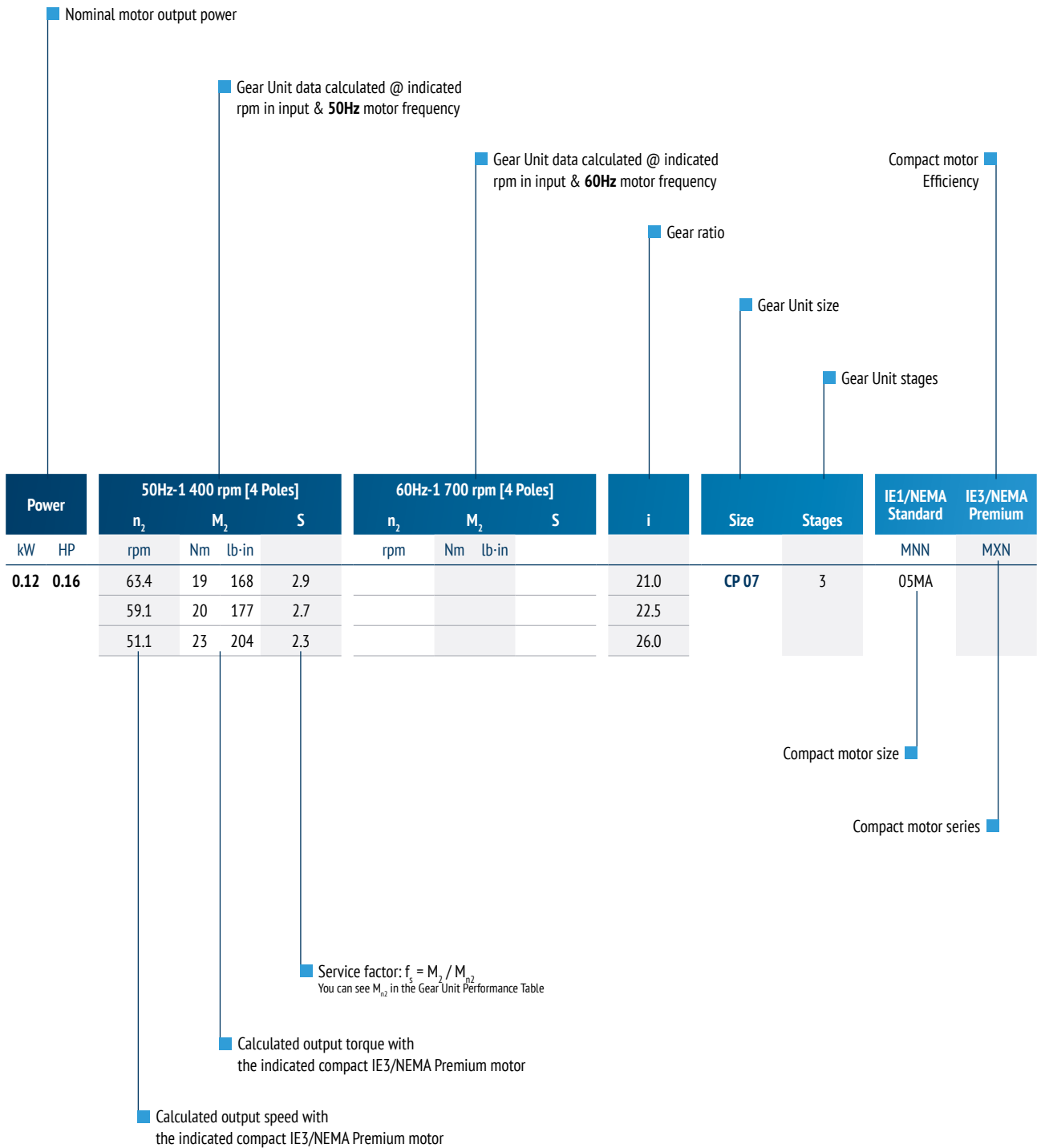

Performance data calculated at a temperature of 25°C, and altitude < 1000m.

Refer to the [Configuration Guidelines & Setup](#) section, before configuring the motor, to select the correct power.

Power		50Hz-1 400 rpm [4 Poles]				60Hz-1 700 rpm [4 Poles]				i	Size	Stages	IE1/NEMA Standard	IE3/NEMA Premium				
kW	HP	n ₂	M ₂	S	n ₂	M ₂	S					MNN	MXN					
		rpm	Nm	lb-in	rpm	Nm	lb-in											
0.18	0.25	47.2	35	310	2.8				27.2	CP 17	3	05MB	05MB					
		41.1	41	363	2.5				31.3									
		35.7	47	416	2.1	45.5	36	319	2.8					36.0				
		33.1	50	442	2	42.3	39	345	2.6					38.8				
		30.7	54	478	1.8	39.2	42	372	2.4					41.8				
		26.4	63	558	1.6	33.7	49	434	2.1					48.7				
		24.5	68	602	1.5	31.3	52	460	1.9					52.4				
		22.7	74	655	1.4	29.0	57	504	1.8					56.6				
		19.4	86	761	1.2	24.8	66	584	1.5					66.2				
		16.4	102	903	1	20.9	78	690	1.3					78.5				
					19.1	86	761	1.2	85.9									
		24.0	70	619	2.9				53.6	CP 37	3	05MB	05MB					
		22.1	76	673	2.6				58.2									
		21.3	79	699	2.5				60.4									
		18.8	89	788	2.2	24.0	68	602	2.9					68.5				
		17.6	95	841	2.1	22.5	73	646	2.7					73.1				
		15.4	109	965	1.8	19.6	84	743	2.4					83.6				
		14.3	117	1 035	1.7	18.3	90	796	2.2					89.7				
		12.4	135	1 195	1.5	15.8	104	920	1.9					104.0				
		10.5	159	1 407	1.3	13.4	122	1 080	1.6					122.1				
		9.7	173	1 531	1.2	12.3	133	1 177	1.5					133.2				
		14.2	117	1 035	2.9				90.4	CP 47	3	05MB	05MB					
		13.4	125	1 106	2.7				96.1									
		11.7	142	1 257	2.4				109.4									
		11.0	152	1 345	2.2	14.0	117	1 035	2.9					117.1				
		9.5	176	1 558	1.9	12.1	135	1 195	2.5					135.1				
		8.1	205	1 814	1.6	10.4	158	1 398	2.1					158.0				
		7.5	223	1 973	1.5	9.5	172	1 522	1.9					171.9				
0.25	0.33	126.1	19	168	2.9				10.6					CP 07	2	05MC		
		117.0	21	186	2.7				11.5									
		99.9	24	212	2.3	126.4	19	168	2.9									13.4
		84.3	29	257	1.9	106.7	22	195	2.5	15.9								
		77.0	31	274	1.8	97.4	24	212	2.3	17.4								
		63.9	38	336	1.5	80.8	29	257	1.9	21.0	CP 07	3	05MC					
		59.5	41	363	1.4	75.3	32	283	1.7	22.5								
		51.5	47	416	1.2	65.1	36	319	1.5	26.0								
		47.7	51	451	1.1	60.4	39	345	1.4	28.1								
		40.8	59	522	0.9	51.6	46	407	1.2	32.9								
				43.5	55	487	1	38.9										
				39.5	60	531	0.9	42.9										

EVOX Coaxial Gearmotor

Performance Table

Power		50Hz-1 400 rpm [4 Poles]				60Hz-1 700 rpm [4 Poles]				i	Size	Stages	IE1/NEMA Standard	IE3/NEMA Premium		
kW	HP	n ₂	M ₂		S	n ₂	M ₂		S				MNN	MXN		
		rpm	Nm	lb-in		rpm	Nm	lb-in								
0.25	0.33	68.0	35	310	2.8					19.7	CP 17	2	05MC			
		57.9	42	372	2.4				23.2							
		53.1	45	398	2.2	67.2	35	310	2.8	25.2						
		49.2	49	434	2	62.2	38	336	2.6	27.2	CP 17	3	05MC			
		42.9	56	496	1.8	54.2	44	389	2.3	31.3						
		37.2	65	575	1.5	47.0	50	442	2	36.0						
		34.6	70	619	1.4	43.7	54	478	1.8	38.8						
		32.0	75	664	1.3	40.5	59	522	1.7	41.8						
		27.5	88	779	1.1	34.8	68	602	1.5	48.7						
		25.6	94	832	1.1	32.3	73	646	1.4	52.4						
		23.7	102	903	1	30.0	79	699	1.3	56.6						
							25.6	93	823	1.1					66.2	
					21.6	110	973	0.9	78.5							
35.0	69	611	2.9					38.3	CP 37	3	05MC					
32.8	74	655	2.7				40.9									
28.6	84	743	2.4				46.8									
26.7	90	796	2.2	33.8	70	619	2.8	50.2								
25.0	96	850	2.1	31.6	75	664	2.7	53.6								
23.0	105	929	1.9	29.1	82	726	2.5	58.2								
22.2	109	965	1.8	28.0	85	752	2.4	60.4								
19.6	123	1 088	1.6	24.8	96	850	2.1	68.5								
18.3	131	1 159	1.5	23.2	102	903	2	73.1								
16.0	150	1 327	1.3	20.3	117	1 035	1.7	83.6								
14.9	161	1 425	1.2	18.9	126	1 115	1.6	89.7								
12.9	187	1 655	1.1	16.3	146	1 292	1.4	104.0								
11.0	220	1 947	0.9	13.9	171	1 513	1.2	122.1								
					12.7	186	1 646	1.1	133.2							
18.7	129	1 142	2.6					71.6	CP 47	3	05MC					
16.7	144	1 274	2.3	21.1	112	991	3	80.2								
14.8	163	1 442	2.1	18.8	127	1 124	2.6	90.4								
13.9	173	1 531	1.9	17.6	135	1 195	2.5	96.1								
12.3	197	1 743	1.7	15.5	153	1 354	2.2	109.4								
11.4	211	1 867	1.6	14.5	164	1 451	2	117.1								
9.9	243	2 150	1.4	12.5	189	1 673	1.8	135.1								
8.5	284	2 513	1.2	10.7	221	1 956	1.5	158.0								
7.8	309	2 735	1.1	9.9	241	2 133	1.4	171.9								
123.1	19	168	2.8					11.5					CP 07	2	10MA	10MA
105.1	23	204	2.4	128.6	19	168	2.9	13.4								
88.7	27	239	2	108.6	22	195	2.5	15.9								
81.1	30	265	1.9	99.2	24	212	2.3	17.4								

Power		50Hz-1 400 rpm [4 Poles]				60Hz-1 700 rpm [4 Poles]				i	Size	Stages	IE1/NEMA Standard	IE3/NEMA Premium					
kW	HP	n ₂	M ₂	S	n ₂	M ₂	S		MNN				MXN						
0.25	0.33	67.2	36	319	1.5	82.2	29	257	1.9	21.0	CP 07	3	10MA	10MA					
		62.7	38	336	1.4	76.6	32	283	1.7	22.5									
		54.2	44	389	1.2	66.3	36	319	1.5	26.0									
		50.2	48	425	1.2	61.5	39	345	1.4	28.1									
		42.9	56.0	496	1.0	52.5	46	407	1.2	32.9									
						44.3	55	487	1	38.9									
						40.2	60	531	0.9	42.9									
		71.5	34	301	3					19.7	19.7	CP 17	2	10MA	10MA				
		60.9	39	345	2.5					23.2	23.2								
		55.9	43	381	2.3	68.4	35	310	2.8	25.2	25.2								
		51.8	46	407	2.2	63.3	38	336	2.6	27.2	27.2	CP 17	3	10MA	10MA				
		45.1	53	469	1.9	55.2	44	389	2.3	31.3	31.3								
		39.1	61	540	1.6	47.9	50	442	2	36.0	36.0								
		36.4	66	584	1.5	44.5	54	478	1.8	38.8	38.8								
		33.7	71	628	1.4	41.3	59	522	1.7	41.8	41.8								
		28.9	83	735	1.2	35.4	68	602	1.5	48.7	48.7								
		26.9	89.0	788	1.1	32.9	73	646	1.4	52.4	52.4								
		24.9	96.0	850	1.0	30.5	79	699	1.3	56.6	56.6								
						26.1	93	823	1.1	66.2	66.2								
						22.0	110	973	0.9	78.5	78.5								
		34.5	70	619	2.9					40.9	40.9					CP 37	3	10MA	10MA
		30.1	80	708	2.5					46.8	46.8								
		28.1	85	752	2.3	34.4	70	619	2.8	50.2	50.2								
		26.3	91	805	2.2	32.2	75	664	2.7	53.6	53.6								
		24.2	99	876	2	29.6	82	726	2.5	58.2	58.2								
		23.3	103	912	1.9	28.5	85	752	2.4	60.4	60.4								
		20.6	116	1 027	1.7	25.2	96	850	2.1	68.5	68.5								
		19.3	124	1 097	1.6	23.6	102	903	2	73.1	73.1								
		16.9	142	1 257	1.4	20.6	117	1 035	1.7	83.6	83.6								
		15.7	152	1 345	1.3	19.2	126	1 115	1.6	89.7	89.7								
		13.6	177.0	1 566	1.1	16.6	146	1 292	1.4	104.0	104.0								
		11.5	208.0	1 841	1.0	14.1	171	1 513	1.2	122.1	122.1								
						13.0	186	1 646	1.1	133.2	133.2								
		19.7	122	1 080	2.8					71.6	71.6	CP 47	3	10MA	10MA				
		17.6	136	1 204	2.5	21.5	112	991	3	80.2	80.2								
		15.6	154	1 363	2.2	19.1	127	1 124	2.6	90.4	90.4								
14.7	163	1 442	2	17.9	135	1 195	2.5	96.1	96.1										
12.9	186	1 646	1.8	15.8	153	1 354	2.2	109.4	109.4										
12.0	199	1 761	1.7	14.7	164	1 451	2	117.1	117.1										
10.4	230	2 035	1.5	12.8	189	1 673	1.8	135.1	135.1										
8.9	269	2 381	1.2	10.9	221	1 956	1.5	158.0	158.0										
8.2	292	2 584	1.1	10.0	241	2 133	1.4	171.9	171.9										

EVOX Coaxial Gearmotor

Performance Table

Power		50Hz-1 400 rpm [4 Poles]				60Hz-1 700 rpm [4 Poles]				i	Size	Stages	IE1/NEMA Standard	IE3/NEMA Premium				
kW	HP	n ₂	M ₂	S	n ₂	M ₂	S	MNN	MXN									
0.37	0.50	208.3	17	150	2.9				6.9	CP 07	2	10MB	10MB					
		190.3	19	168	2.7				7.5									
		179.0	20	177	2.8				8.0									
		155.7	23	204	2.4	190.0	18	159	3					9.2				
		144.9	25	221	2.2	176.8	20	177	2.8					9.9				
		134.6	27	239	2.1	164.3	21	186	2.6					10.6				
		124.8	29	257	1.9	152.3	23	204	2.4					11.5				
		106.6	34	301	1.6	130.1	27	239	2.1					13.4				
		90.0	40	354	1.4	109.8	32	283	1.7					15.9				
		82.2	43	381	1.3	100.3	35	310	1.6					17.4				
		68.2	52	460	1	83.2	42	372	1.3	21.0	CP 07	3	10MB	10MB				
		63.5	56.0	496	1.0	77.5	45	398	1.2	22.5								
						67.0	52	460	1.1	26.0								
						62.2	56	496	1	28.1								
		103.3	35	310	2.9					13.8	CP 17	2	10MB	10MB				
		90.3	40	354	2.5					15.8								
		84.2	42	372	2.4	102.7	34	301	2.9	17.0								
		72.6	49	434	2	88.5	39	345	2.5	19.7								
		61.8	58	513	1.7	75.4	46	407	2.2	23.2								
		56.7	63	558	1.6	69.2	50	442	2	25.2								
		52.5	68	602	1.5	64.1	54	478	1.8	27.2					CP 17	3	10MB	10MB
		45.8	78	690	1.3	55.8	62	549	1.6	31.3								
		39.7	90	796	1.1	48.4	72	637	1.4	36.0								
		36.9	97	858	1	45.0	78	690	1.3	38.8								
		34.2	105	929	1	41.7	84	743	1.2	41.8								
						35.8	97	858	1	48.7								
						33.3	105	929	1	52.4	CP 37	3	10MB	10MB				
		47.7	75	664	2.7					30.0								
		42.3	85	752	2.4	51.6	68	602	3	33.8								
		37.3	96	850	2.1	45.5	77	681	2.6	38.3								
		35.0	102	903	2	42.7	82	726	2.4	40.9								
		30.6	117	1 035	1.7	37.3	94	832	2.1	46.8								
		28.5	126	1 115	1.6	34.8	100	885	2	50.2								
		26.7	134	1 186	1.5	32.6	107	947	1.9	53.6								
		24.6	146	1 292	1.4	30.0	116	1 027	1.7	58.2								
		23.7	151	1 336	1.3	28.9	121	1 071	1.7	60.4								
20.9	171	1 513	1.2	25.5	137	1 212	1.5	68.5										
19.6	183.0	1 619	1.1	23.9	146	1 292	1.4	73.1										
17.1	209.0	1 850	1.0	20.9	167	1 478	1.2	83.6										
				19.5	179	1 584	1.1	89.7										
				16.8	208	1 841	1	104.0										

Power		50Hz-1 400 rpm [4 Poles]				60Hz-1 700 rpm [4 Poles]				i	Size	Stages	IE1/NEMA Standard	IE3/NEMA Premium	
kW	HP	n ₂	M ₂		S	n ₂	M ₂		S				MNN	MXN	
		rpm	Nm	lb-in		rpm	Nm	lb-in							
0.37	0.50	33.9	105	929	2.9					42.1	CP 47	3	10MB	10MB	
		29.8	120	1 062	2.8					47.9					
		27.9	128	1 133	2.6					51.3					
		25.8	139	1 230	2.2	31.5	111	982	2.8	55.4					
		23.5	152	1 345	2.2	28.7	122	1 080	2.8	60.8					
		20.0	179	1 584	1.9	24.4	143	1 265	2.3	71.6					
		17.8	201	1 779	1.7	21.8	160	1 416	2.1	80.2					
		15.8	226	2 000	1.5	19.3	181	1 602	1.9	90.4					
		14.9	240	2 124	1.4	18.2	192	1 699	1.7	96.1					
		13.1	273	2 416	1.2	16.0	219	1 938	1.5	109.4					
		12.2	293.0	2 593	1.1	14.9	234	2 071	1.4	117.1					
		10.6	338.0	2 991	1.0	12.9	270	2 389	1.2	135.1					
							11.0	316	2 796	1.1					158.0
							10.2	344	3 044	1					171.9
		0.37	0.50	347.8	15	133	2.7								
300.8	17			150	2.6					4.6					
278.9	19			168	2.4	343.6	15	133	2.9	5.0					
238.2	22			195	2.3	293.5	18	159	2.8	5.8					
201.1	26			230	1.9	247.7	21	186	2.3	6.9					
183.7	29			257	1.8	226.3	23	204	2.2	7.5					
172.7	30			265	1.8	212.8	25	221	2.2	8.0					
150.2	35			310	1.6	185.1	28	248	1.9	9.2					
139.8	38			336	1.5	172.2	31	274	1.8	9.9					
129.9	40			354	1.4	160.0	33	292	1.7	10.6					
120.5	44			389	1.3	148.4	36	319	1.5	11.5					
102.9	51			451	1.1	126.8	42	372	1.3	13.4					
86.8	60.0			531	0.9	107.0	49	434	1.1	15.9					
						97.7	54	478	1	17.4					
0.37	0.50			196.0	27	239	3					7.0	CP 17	2	10MC
		182.8	29	257	2.8					7.6					
		161.8	32	283	2.8					8.5					
		136.0	39	345	2.5					10.2					
		120.5	44	389	2.3	148.5	35	310	2.8	11.5					
		106.3	49	434	2	131.0	40	354	2.5	13.0					
		99.7	53	469	1.9	122.8	43	381	2.3	13.8					
		87.1	60	531	1.7	107.3	49	434	2	15.8					
		81.2	65	575	1.5	100.1	53	469	1.9	17.0					
		70.0	75	664	1.3	86.3	61	540	1.6	19.7					
		59.6	88	779	1.1	73.4	72	637	1.4	23.2					
		54.7	96	850	1	67.4	78	690	1.3	25.2					

EVOX Coaxial Gearmotor

Performance Table

Power		50Hz-1 400 rpm [4 Poles]				60Hz-1 700 rpm [4 Poles]				i	Size	Stages	IE1/NEMA Standard	IE3/NEMA Premium	
kW	HP	n ₂	M ₂		S	n ₂	M ₂		S						
		rpm	Nm	lb-in		rpm	Nm	lb-in				MNN	MXN		
0.55	0.75	50.7	104	920	1	62.4	84	743	1.2	27.2	CP 17	3	10MC		
							54.4	97	858	1					31.3
		176.2	30	265	2.9										7.8
												CP 37	2	10MC	
		152.8	34	301	2.6	188.3	28	248	3	9.0					
		130.7	40	354	2.3	161.0	33	292	2.6	10.6					
		76.7	68	602	2.9					18.0					
		71.7	73	646	2.7					19.3					
		62.1	85	752	2.4	76.4	69	611	2.9	22.2					
		53.1	99	876	2	65.4	81	717	2.5	26.0		CP 37	3	10MC	
		46.0	114	1 009	1.8	56.7	93	823	2.2	30.0					
		40.8	129	1 142	1.6	50.2	105	929	1.9	33.8					
		36.0	146	1 292	1.4	44.3	119	1 053	1.7	38.3					
		33.7	155	1 372	1.3	41.6	127	1 124	1.6	40.9					
		29.5	178	1 575	1.1	36.3	145	1 283	1.4	46.8					
		27.5	191	1 690	1	33.9	156	1 381	1.3	50.2					
		25.8	204	1 805	1	31.7	166	1 469	1.2	53.6					
		23.7	221	1 956	0.9	29.2	181	1 602	1.1	58.2					
							28.1	187	1 655	1.1	60.4				
							24.8	212	1 876	0.9	68.5				
		60.8	86	761	2.9					22.7	CP 47				
		52.9	99	876	2.6	65.1	81	717	3	26.1					
		45.4	115	1 018	2.3	56.0	94	832	2.6	30.4					
		41.8	125	1 106	2.1	51.5	102	903	2.5	33.0		CP 47	3	10MC	
		51.8	101	894	2.9					26.6					
		44.0	119	1 053	2.6	54.2	97	858	3	31.4					
		39.2	134	1 186	2.3	48.4	109	965	2.7	35.2					
		34.8	150	1 327	2.1	42.9	123	1 088	2.5	39.6					
		32.8	160	1 416	1.9	40.4	131	1 159	2.4	42.1					
		28.8	182	1 611	1.8	35.5	149	1 319	2.2	47.9					
26.9	195	1 726	1.7	33.1	159	1 407	2.1	51.3							
24.9	211	1 867	1.5	30.7	172	1 522	1.8	55.4							
22.7	231	2 044	1.5	28.0	188	1 664	1.8	60.8							
19.3	272	2 407	1.2	23.8	222	1 965	1.5	71.6							
17.2	305	2 699	1.1	21.2	249	2 204	1.3	80.2							
15.3	343	3 035	1	18.8	280	2 478	1.2	90.4							
14.4	365	3 230	0.9	17.7	298	2 637	1.1	96.1							
					15.5	339	3 000	1	109.4						
					14.5	363	3 212	0.9	117.1						

Power		50Hz-1 400 rpm [4 Poles]				60Hz-1 700 rpm [4 Poles]				i	Size	Stages	IE1/NEMA Standard	IE3/NEMA Premium				
kW	HP	n ₂	M ₂		S	n ₂	M ₂		S				MNN	MXN				
		rpm	Nm	lb-in		rpm	Nm	lb-in										
0.55	0.75	193.4	27	239	2.9					7.6	CP 17	2	20MA	20MA				
		171.2	31	274	2.9				8.5									
		143.8	37	327	2.6				10.2									
		127.5	41	363	2.4	154.1	34	301	2.9	11.5								
		112.5	47	416	2.1	136.0	39	345	2.6	13.0								
		105.5	50	442	2	127.5	42	372	2.4	13.8								
		92.2	57	504	1.8	111.4	48	425	2.1	15.8								
		85.9	61	540	1.6	103.9	51	451	2	17.0								
		53.6	98	867	1	64.8	82	726	1.2	27.2					CP 17	3	20MA	20MA
						56.5	94	832	1.1	31.3								
						49.0	108	956	0.9	36.0								
				75.8	69	611	2.9				19.3	CP 37	2	20MA	20MA			
				48.7	108	956	1.9	58.8	90	796	2.2	30.0	CP 37	3	20MA	20MA		
				43.1	122	1 080	1.6	52.2	102	903	2	33.8						
				38.1	138	1 221	1.4	46.0	115	1 018	1.7	38.3						
				35.7	147	1 301	1.4	43.1	123	1 088	1.6	40.9						
				31.2	168	1 487	1.2	37.7	140	1 239	1.4	46.8						
				29.1	181	1 602	1.1	35.2	151	1 336	1.3	50.2						
				27.3	193	1 708	1	32.9	161	1 425	1.2	53.6						
				24.2	218	1 929	0.9	29.2	181	1 602	1.1	60.4						
								25.8	205	1 814	1	68.5						
								24.2	219	1 938	0.9	73.1						
				46.5	113	1 000	2.7				31.4	CP 47	3	20MA	20MA			
				41.5	127	1 124	2.4	50.2	105	929	2.8					35.2		
				36.9	143	1 265	2.2	44.6	119	1 053	2.6					39.6		
				34.7	152	1 345	2	41.9	126	1 115	2.5					42.1		
				30.5	173	1 531	1.9	36.8	144	1 274	2.3					47.9		
				28.5	185	1 637	1.8	34.4	154	1 363	2.2					51.3		
				26.3	200	1 770	1.6	31.8	166	1 469	1.9					55.4		
				24.0	219	1 938	1.5	29.0	182	1 611	1.8					60.8		
				20.4	258	2 283	1.3	24.7	215	1 903	1.6					71.6		
				18.2	289	2 558	1.2	22.0	241	2 133	1.4					80.2		
		16.2	325	2 876	1	19.5	271	2 398	1.2	90.4								
		15.2	346	3 062	1	18.4	288	2 549	1.2	96.1								
						16.1	328	2 903	1	109.4								
						15.1	351	3 106	1	117.1								

EVOX Coaxial Gearmotor

Performance Table

Power		50Hz-1 400 rpm [4 Poles]				60Hz-1 700 rpm [4 Poles]				i	Size	Stages	IE1/NEMA Standard	IE3/NEMA Premium	
kW	HP	n ₂	M ₂	S	n ₂	M ₂	S	MNN	MXN						
		rpm	Nm	lb-in		rpm	Nm	lb-in							
0.75	1.00	323.7	22	195	2.9					4.5	CP 17	2	20MB	20MB	
		286.8	25	221	2.8					5.1					
		253.5	28	248	2.7					5.8					
		237.4	30	265	2.5					6.2					
		207.4	34	301	2.3	251.4	28	248	2.8	7.0					
		193.4	37	327	2.2	234.4	30	265	2.6	7.6					
		171.2	42	372	2.2	207.5	34	301	2.6	8.5					
		143.8	50	442	1.9	174.4	41	363	2.3	10.2					
		127.5	56	496	1.8	154.6	46	407	2.2	11.5					
		112.5	64	566	1.6	136.4	52	460	1.9	13.0					
		105.5	68	602	1.5	127.9	55	487	1.8	13.8					
		92.2	78	690	1.3	111.7	63	558	1.6	15.8					
		85.9	83	735	1.2	104.2	68	602	1.5	17.0					
							65.0	109	965	0.9					27.2
											13.2	CP 37	2	20MB	20MB
											15.8				
							98.3	72	637	2.8	18.0				
							91.9	77	681	2.6	19.3				
							59.0	120	1 062	1.7	30.0				
							52.3	135	1 195	1.5	33.8				
							46.2	153	1 354	1.3	38.3				
							43.3	164	1 451	1.2	40.9				
							37.8	187	1 655	1.1	46.8				
							35.3	201	1 779	1	50.2				
							33.0	214	1 894	0.9	53.6				
											21.3	CP 47	2	20MB	20MB
											22.7				
											24.3	CP 47	3	20MB	20MB
					72.9	97	858	2.7	26.6						
					66.5	107	947	2.6	31.4						
					56.4	125	1 106	2.3	35.2						
					50.3	141	1 248	2.1	39.6						
					44.7	158	1 398	2	42.1						
					42.0	169	1 496	1.8	47.9						
					36.9	192	1 699	1.7	51.3						
					34.5	205	1 814	1.6	55.4						
					31.9	222	1 965	1.4	60.8						
					29.1	243	2 150	1.4	71.6						
					24.7	286	2 531	1.2	80.2						
					22.1	321	2 841	1	90.4						
					19.6	361	3 195	0.9							

Power		50Hz-1 400 rpm [4 Poles]				60Hz-1 700 rpm [4 Poles]				i	Size	Stages	IE1/NEMA Standard	IE3/NEMA Premium	
kW	HP	n ₂	M ₂	S	n ₂	M ₂	S	MNN	MXN						
		rpm	Nm	lb-in	rpm	Nm	lb-in								
1.1	1.50	339.6	31	274	2.8				4.3	CP 37	2			25S	
		225.5	46	407	2.8				6.4						
		185.2	56	496	2.4	225.4	47	416	2.7						7.8
		145.0	72	637	2.3	176.5	60	531	2.7						10.0
		123.1	85	752	2.1	149.8	71	628	2.5						11.8
		109.8	95	841	1.9	133.7	79	699	2.3						13.2
		91.7	114	1 009	1.7	111.6	95	841	2						15.8
		80.6	130	1 150	1.5	98.1	108	956	1.9						18.0
		75.3	139	1 230	1.4	91.6	116	1 027	1.7						19.3
		48.3	216	1 912	0.9	58.8	180	1 593	1.1						30.0
				52.2	203	1 796	1	33.8	CP 37	3			25S		
								8.0	CP 47	2			25S		
182.2	57	504	2.9					12.2							
119.3	87	770	2.9					14.2							
102.3	102	903	2.6					15.8							
91.8	114	1 009	2.4	111.7	95	841	2.9	17.7							
81.9	127	1 124	2.3	99.7	106	938	2.7	18.8							
77.2	135	1 195	2.2	94.0	113	1 000	2.6	21.3							
68.2	153	1 354	2	83.0	128	1 133	2.4	22.7							
63.8	164	1 451	1.9	77.7	136	1 204	2.3	24.3							
59.7	175	1 549	1.6	72.7	146	1 292	1.8	26.6							
54.4	192	1 699	1.5	66.3	160	1 416	1.7	31.4							
46.2	226	2 000	1.4	56.3	188	1 664	1.5	35.2							
41.2	253	2 239	1.2	50.2	211	1 867	1.4	39.6							
36.6	285	2 522	1.1	44.6	238	2 106	1.3	42.1							
34.4	303	2 681	1	41.9	253	2 239	1.2	47.9							
30.2	345	3 053	1	36.8	288	2 549	1.1	51.3							
28.3	369	3 265	0.9	34.4	308	2 726	1.1	55.4							
				31.8	333	2 947	0.9	60.8							
				29.0	365	3 230	0.9								
1.5	2.00	538.9	26	230	2.8				2.7	CP 37	2			25L	
		457.5	31	274	2.5	553.5	26	230	2.8						3.2
		358.4	40	354	2.8										4.1
		340.7	42	372	2	412.2	35	310	2.3						4.3
		304.4	47	416	2.5	368.2	39	345	2.8						4.8
		271.5	53	469	2.3	328.4	43	381	2.6						5.4
		226.3	63	558	2	273.7	52	460	2.3						6.4
		185.8	77	681	1.8	224.8	63	558	2						7.8
		145.5	98	867	1.7	176.0	81	717	2						10.0
		123.5	115	1 018	1.5	149.4	95	841	1.8						11.8
		110.2	129	1 142	1.4	133.3	107	947	1.7						13.2
		92.0	155	1 372	1.3	111.3	128	1 133	1.5						15.8
		80.8	176	1 558	1.1	97.8	146	1 292	1.4						18.0
		75.5	189	1 673	1.1	91.4	156	1 381	1.3						19.3

EVOX Coaxial Gearmotor

Performance Table

Power		50Hz-1 400 rpm [4 Poles]				60Hz-1 700 rpm [4 Poles]				i	Size	Stages	IE1/NEMA Standard	IE3/NEMA Premium
kW	HP	n ₂	M ₂	S	n ₂	M ₂	S	MNN	MXN					
1.5	2.00	485.0	29	257	2.8					3.0	CP 47	2		25L
		436.9	33	292	2.8					3.3				
		295.7	48	425	2.8					4.9				
		266.0	54	478	2.8					5.5				
		228.1	63	558	2.5	275.9	52	460	2.8	6.4				
		204.6	70	619	2.3	247.5	58	513	2.6	7.1				
		182.8	78	690	2.1	221.1	64	566	2.4	8.0				
		169.4	84	743	2.6					8.6				
		150.3	95	841	2.4	181.8	78	690	2.9	9.7				
		133.0	107	947	2.3	160.9	89	788	2.8	10.9				
		119.8	119	1 053	2.1	144.9	98	867	2.5	12.2				
		102.6	139	1 230	1.9	124.1	115	1 018	2.3	14.2				
		92.1	155	1 372	1.8	111.4	128	1 133	2.2	15.8				
		82.2	173	1 531	1.7	99.4	143	1 265	2	17.7				
		77.5	184	1 628	1.6	93.7	152	1 345	2	18.8				
		68.4	208	1 841	1.5	82.7	172	1 522	1.8	21.3				
		64.1	223	1 973	1.4	77.5	184	1 628	1.7	22.7				
		59.9	238	2 106	1.2	72.5	197	1 743	1.3	24.3	CP 47	3		25L
		54.6	261	2 310	1.1	66.1	216	1 912	1.3	26.6				
		46.4	307	2 717	1	56.1	254	2 248	1.1	31.4				
				50.1	285	2 522	1	35.2						
				44.4	321	2 841	1	39.6						
				41.8	341	3 018	0.9	42.1						

2.2

From 2,2 to 7,5 kW coming soon

Performances

EVOX Coaxial Gear Unit

Tables introduction

The following tables show geometrically possible combinations between gear ratios and inputs for each gear unit size.

For each of these combinations, we have calculated a possible service factor using the maximum motor power that can be coupled in Bonfiglioli's asynchronous electric motors portfolio (considering different poles and efficiency levels). In the table, combinations with a service factor below 0.9 are highlighted with a lighter color. Here you should pay attention to the power of the electric motor coupled with the gear unit, because it shouldn't exceed the "Maximum input power" shown in the table.

The left table section shows the inputs that are geometrically compatible with each gear ratio by IEC, NEMA and solid input shaft size. For further information on the input interface dimensions, see the Dimension section of this document.

Nominal output torque calculated at maximum radial load on the output shaft.

Performance data calculated at a temperature of 25°C and altitude < 1000m.

Gear unit size

Nominal output torque
[Service factor =1]

Input speed

Output speed
Gearbox performance data is calculated at 1400 rpm, data at 1700 rpm will be available soon. For IEC asynchronous gearmotors, consider the performance table of the EVOX CP gearmotor as a reference. For configurations not listed in that section, please consider the Max Input Power Pn on these pages as a limit not to be exceeded even at 60Hz.

Max input power
[@ 1400rpm input & service factor =1]

Max radial loads are calculated with:

- M_{r2} torque applied on output shaft
- Worst Gear Unit rotating direction [CW or CCW]
- The radial force applied with the worst calculated angle α for each gear ratio
- Radial load installed in the middle of the output shaft

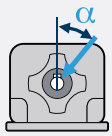

The permitted radial loads can increase considerably when the parameters listed above vary. [Contact Bonfiglioli's Technical Service](#) if your application requires radial loads greater than the values indicated in the tables, because they may be available with a standard gear unit or with a simple option

Nominal output torque

NEMA motor adapters size

IEC motor adapters size

... Nm

	EVOX CP						Motor adapters										Solid shaft								
	[n ₁ =1 400rpm]			Max guaranteed Radial loads			IEC	P56	P63	P71	P80	P90	P100	P112	P132	NEMA		N56	N143	N145	N182	N184	N213	N215	
	i	Mn ₂	n ₂	Pn ₁	Standard	OHR																			
		Nm	rpm	kW	N	N																			
2 stages	24	45	583	2.7	CTS	CTS																			HS1/NHS1

Stage no.

Gear ratio

Max guaranteed radial loads with standard bearings

Max guaranteed radial loads with OHR option active

Adapter can be coupled
[Input power shouldn't exceed the "Max input power"]

Adapter cannot be coupled

Solid input shaft size
[Compatible with gear ratio]

EVOX Coaxial Gear Unit

Performance Table

EVOX CP07

55 Nm

	i	[n ₁ =1 400rpm]		Max Guaranteed Radial Loads		Motor adapters											
		Mn ₂ Nm	n ₂ rpm	Pn ₁ kW	Standard N	OHR N	IEC	P56	P63	P71	P80	P90	P100	P112	P132		
2 stages	2.8	35	497	1.8	CTS	800	CTS	NEMA	-	-	N56C	N143TC	N145TC	N182TC	N184TC	N213TC	N215TC
	3.2	37	434	1.7													
	3.5	40	406	1.7													
	4.0	40	353	1.5													
	4.6	45	305	1.4													
	4.9	45	283	1.3													
	5.8	50	242	1.3													
	6.9	50	204	1.1													
	7.5	51	186	1.0													
	8.0	55	175	1.0													
	9.2	55	152	0.9													
	9.9	55	142	0.8													
	10.6	55	132	0.8													
	11.5	55	122	0.7													
	13.4	55	104	0.6													
	15.9	55	88	0.5													
	17.4	55	80	0.5													
3 stages	21.0	55	67	0.4	1 600	CTS	CTS	NEMA	-	-	N56C	N143TC	N145TC	N182TC	N184TC	N213TC	N215TC
	22.5	55	62	0.4													
	26.0	55	54	0.3													
	28.1	55	50	0.3													
	32.9	55	43	0.2													
	38.9	55	36	0.2													
	42.9	55	33	0.2													
	46.1	55	30	0.2													
	49.6	55	28	0.2													
	53.5	55	26	0.2													
	62.6	55	22	0.1													
	74.2	55	19	0.1													
	81.2	55	17	0.1													

Gearbox performance data is calculated at 1400 rpm, data at 1700 rpm will be available soon. For IEC asynchronous gearmotors, consider the performance table of the EVOX CP gearmotor as a reference. For configurations not listed in that section, please consider the Max Input Power Pn on this page as a limit not to be exceeded even at 60Hz.

Maximum Guaranteed Radial Loads: if table value is CST or required values exceed the one indicated on the table, please [contact Bonfiglioli technical service](#)

Maximum Guaranteed Axial Loads: for more information about Standards values or OHA options, please [contact Bonfiglioli technical service](#)

Input power shouldn't exceed the "Max input power"

Please, configure N140TC, to have the N143TC or N145TC input flange; or configure N180TC, if you want the N182TC or N184TC; or select N210TC, to have the N213TC or N215TC

EVOX CP17

100 Nm

	[n ₁ =1 400rpm]				Max Guaranteed Radial Loads		Motor adapters									Solid shaft	
	i	Mn ₂	n ₂	Pn ₁	Standard	OHR	IEC	P56	P63	P71	P80	P90	P100	P112	P132		
	Nm	rpm	kW	N	N		NEMA	-	-	N56C	N143TC	N145TC	N182TC	N184TC	N213TC	N215TC	
2 stages	2.4	45	583	2.7	CTS	CTS											HS1/NHS1
	2.9	50	483	2.5													
	3.3	55	428	2.5													
	3.8	60	369	2.3													
	4.5	65	310	2.1													
	5.1	70	275	2.0													
	5.8	75	243	1.9													
	6.2	75	228	1.8													
	7.0	80	199	1.7													
	7.6	80	185	1.6													
	8.5	90	164	1.5													
	10.2	95	138	1.4													
	11.5	100	122	1.3													
	13.0	100	108	1.1													
	13.8	100	101	1.1													
	15.8	100	88	0.9													
	17.0	100	82	0.9													
	19.7	100	71	0.7													
	23.2	100	60	0.6													
25.2	100	55	0.6														
3 stages	27.2	100	51	0.5	1 770	3 500											
	31.3	100	45	0.5													
	36.0	100	39	0.4													
	38.8	100	36	0.4													
	41.8	100	33	0.4													
	48.7	100	29	0.3													
	52.4	100	27	0.3													
	56.6	100	25	0.3													
	66.2	100	21	0.2													
	78.5	100	18	0.2													
	85.9	100	16	0.2													

Gearbox performance data is calculated at 1400 rpm, data at 1700 rpm will be available soon. For IEC asynchronous gearmotors, consider the performance table of the EVOX CP gearmotor as a reference. For configurations not listed in that section, please consider the Max Input Power Pn on this page as a limit not to be exceeded even at 60Hz.

Maximum Guaranteed Radial Loads: if table value is CST or required values exceed the one indicated on the table, please [contact Bonfiglioli technical service](#)

Maximum Guaranteed Axial Loads: for more information about Standards values or OHA options, please [contact Bonfiglioli technical service](#)

Input power shouldn't exceed the "Max input power"

Please, configure N140TC, to have the N143TC or N145TC input flange; or configure N180TC, if you want the N182TC or N184TC; or select N210TC, to have the N213TC or N215TC

EVOX Coaxial Gear Unit

Performance Table

EVOX CP37

200 Nm

	[n ₁ =1 400rpm]				Max Guaranteed Radial Loads		Motor adapters									Solid shaft				
	i	Mn ₂	n ₂	Pn ₁	Standard	OHR	IEC	P56	P63	P71	P80	P90	P100	P112	P132					
	Nm	rpm	kW	N	N		NEMA	-	-	N56C	N143TC	N145TC	N182TC	N184TC	N213TC	N215TC				
2 stages	2.3	73	622	4.8	CTS	CTS														
	2.7	84	519	4.6																
	3.2	94	440	4.3																
	3.4	103	412	4.4																
	4.1	113	345	4.1																
	4.3	110	328	3.8																
	4.8	121	293	3.7																
	5.4	127	261	3.5																
	6.4	137	218	3.1																
	7.8	148	179	2.8																
	9.0	156	155	2.5																
	10.0	163	140	2.4																
	10.6	166	133	2.3																
	11.8	174	119	2.2																
	13.2	181	106	2.0																
	15.8	194	88	1.8																
	18.0	200	78	1.6																
	19.3	200	73	1.5																
22.2	200	63	1.3	2 250	3 550															
26.0	200	54	1.1																	
3 stages	30.0	200	47	1.0																
	33.8	200	41	0.9																
	38.3	200	37	0.8																
	40.9	200	34	0.7																
	46.8	200	30	0.6																
	50.2	200	28	0.6																
	53.6	200	26	0.5																
	58.2	200	24	0.5																
	60.4	200	23	0.5																
	68.5	200	20	0.4																
	73.1	200	19	0.4	4 500	7 100														
	83.6	200	17	0.4																
	89.7	200	16	0.3																
	104.0	200	13	0.3																
	122.1	200	11	0.2																
133.2	200	11	0.2																	

Gearbox performance data is calculated at 1400 rpm, data at 1700 rpm will be available soon. For IEC asynchronous gearmotors, consider the performance table of the EVOX CP gearmotor as a reference. For configurations not listed in that section, please consider the Max Input Power Pn on this page as a limit not to be exceeded even at 60Hz.

Maximum Guaranteed Radial Loads: if table value is CST or required values exceed the one indicated on the table, please [contact Bonfiglioli technical service](#)

Maximum Guaranteed Axial Loads: for more information about Standards values or OHA options, please [contact Bonfiglioli technical service](#)

Input power shouldn't exceed the "Max input power"

Motor Adapters available only in NEMA version. Input power shouldn't exceed the "Max Input power"

Please, configure N140TC, to have the N143TC or N145TC input flange; or configure N180TC, if you want the N182TC or N184TC; or select N210TC, to have the N213TC or N215TC

EVOX CP47

335 Nm

	[n ₁ =1 400rpm]				Max Guaranteed Radial Loads		Motor adapters									Solid shaft	
	i	Mn ₂	n ₂	Pn ₁	Standard	OHR	IEC	P56	P63	P71	P80	P90	P100	P112	P132		NEMA
	Nm	rpm	kW	N	N		-	-	N56C	N143TC	N145TC	N182TC	N184TC	N213TC	N215TC		
2 stages	2.4	100	593	6.2													HS3/NHS3
	3.0	115	467	5.6													
	3.3	145	420	6.4													
	3.9	152	363	5.8													
	4.4	160	322	5.4													
	4.9	170	285	5.1													
	5.5	180	256	4.8													
	6.4	190	219	4.4													
	7.1	200	197	4.1													
	8.0	210	176	3.9	CTS	CTS											
	8.6	215	163	3.7													
	9.7	225	145	3.4													
	10.9	245	128	3.3													
	12.2	250	115	3.0													
	14.2	265	99	2.7													
	15.8	278	89	2.6													
	17.7	290	79	2.4													
	18.8	297	75	2.3													
	21.3	310	66	2.1													
	22.7	315	62	2.0													
3 stages	24.3	280	58	1.7													HS3/NHS3
	26.6	290	53	1.6													
	31.4	310	45	1.4	2 500	4 250											
	35.2	310	40	1.3													
	39.6	310	35	1.1													
	42.1	310	33	1.1													
	47.9	330	29	1.0													
	51.3	335	27	1.0													
	55.4	310	25	0.8													
	60.8	335	23	0.8													
	71.6	335	20	0.7													
	80.2	335	17	0.6													
	90.4	335	15	0.5													
	96.1	335	15	0.5	5 000	8 500											
	109.4	335	13	0.4													
	117.1	335	12	0.4													
	135.1	335	10	0.4													
	158.0	335	9	0.3													
	171.9	335	8	0.3													

Gearbox performance data is calculated at 1400 rpm, data at 1700 rpm will be available soon. For IEC asynchronous gearmotors, consider the performance table of the EVOX CP gearmotor as a reference. For configurations not listed in that section, please consider the Max Input Power Pn on this page as a limit not to be exceeded even at 60Hz.

Maximum Guaranteed Radial Loads: if table value is CST or required values exceed the one indicated on the table, please [contact Bonfiglioli technical service](#)

Maximum Guaranteed Axial Loads: for more information about Standards values or OHA options, please [contact Bonfiglioli technical service](#)

■ Input power shouldn't exceed the "Max input power"

Please, configure N140TC, to have the N143TC or N145TC input flange; or configure N180TC, if you want the N182TC or N184TC; or select N210TC, to have the N213TC or N215TC

Dimension

EVOX Coaxial Gearmotor

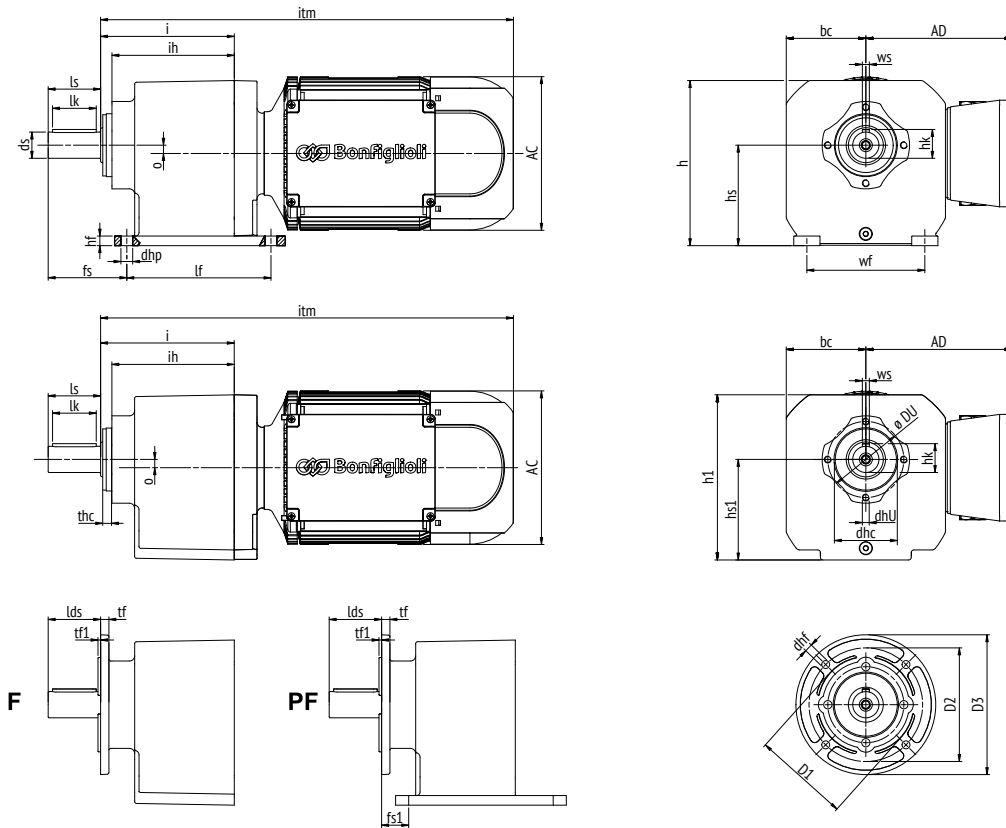

	lf	wf	dhp	hf	hs	h	ih	i	o	bc	h1	hs1	DU	dhU	dhc	lds	thc	tf	tf1
CP07	95	85	6.5	6	65	107	79	84.5	0	51.5	106.5	64.5	60	M6	50	40	4 f7	4.5	4.0
CP17	110	110	9	11	75	134	99	108	0	70	133.5	74.5	87	M8	70	40	5.5 f7	9.5	3.0
CP37	130	110	9	11	90	145	117.5	131	6.4	75	144.5	89.5	87	M8	70	50	6 f7	9.5	3.0
CP47	165	135	13.5	11	115	189	140	153	9.5	91	188.5	114.5	87	M8	70	60	6.5 f7	9.5	3.5
CP57	Coming Soon																		
CP67	Coming Soon																		

MXN - [Compact IE3/NEMA Premium] & MNN - [Compact IE1/NEMA Standard]

Motor size (kW)	05MA (0.12)	10MA (0.25)	20MA (0.55)	25S (1.1)	30LA (2.2)	35M (4)	40S (5.5)	D1	D2	D3	dhf	
05MB (0.18)		10MB (0,37)	20MB (0.75)	25L (1.5)	30LB (3)		40M (7.5)	F120	80 f7	100	120	6.5
05MC (0.25)		10MC (0.55)						F140	95 f7	115	140	6.5
AC	122	138	158	177	Coming Soon							
AD	136	138	148	170	Coming Soon							
itm	Coming soon											
CP07	377	381	-	-	Coming soon							
CP17	389	393	438	443	Coming soon							
CP37	407	411	456	461	Coming soon							
CP47	430	434	479	484	Coming soon							
CP57	Coming soon											
CP67	Coming soon											

Metric [Standard output shaft version]

	ds	ls	lk	hk	ws	fs	fs1
CP07	20 h6	40	32	22.5	6 h9	48	8
CP17	20 h6	40	32	22.5	6 h9	58	18
CP37	25 h6	50	40	33	8 h9	75	25
CP47	30 h6	60	50	33	8 h9	90	30
CP57	Coming Soon						
CP67	Coming Soon						

Imperial [N-output shaft version] - Dimensions expressed in inches

	ds	ls	lk	hk	ws	fs	fs1
CP07	3/4 ^{+0.0000} / _{-0.0005}	1-9/16	-	27/32	3/16 ^{+0.000} / _{-0.001}	1.890	0.315
CP17	3/4 ^{+0.0000} / _{-0.0005}	1-9/16	-	27/32	3/16 ^{+0.000} / _{-0.001}	2.283	0.709
CP37	1 ^{+0.0000} / _{-0.0005}	2	-	1-3/32	1/4 ^{+0.000} / _{-0.001}	2.953	0.984
CP47	1-1/4 ^{+0.0000} / _{-0.0005}	2-3/8	-	1-3/8	1/4 ^{+0.000} / _{-0.001}	3.543	1.181
CP57	Coming Soon						
CP67	Coming Soon						

If not specified, dimensions are expressed in mm

For motor brake and options dimension see [EVOX Electric Motor and Brake Dimension](#)

EVOX Coaxial Gear Unit

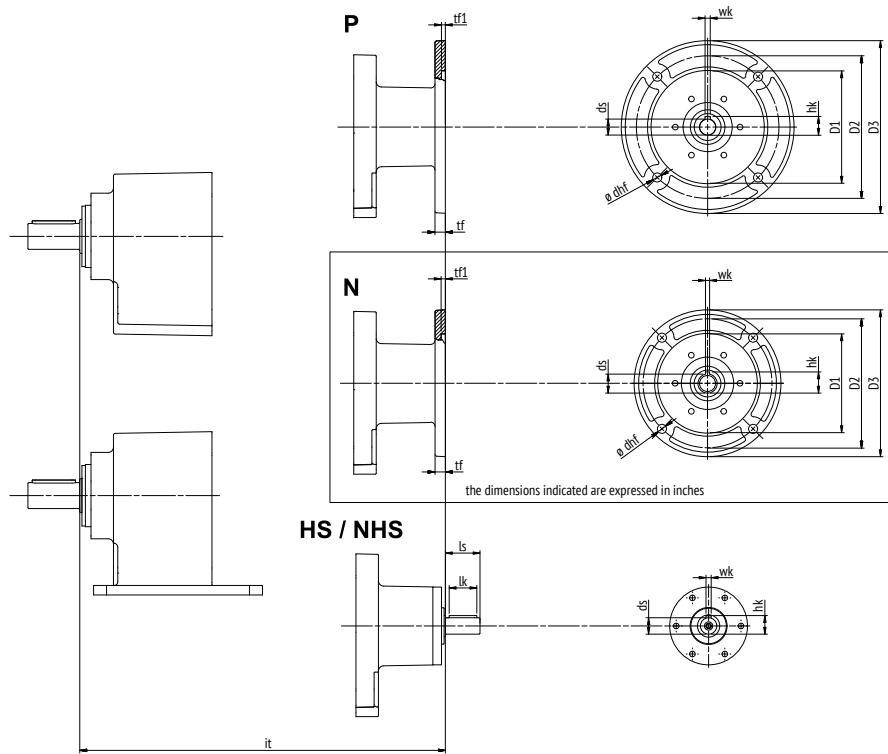

IEC Standard Flanges

	D3	D2	tf	dhf	D1	tf1	ds	hk	wk
Metric dimensions									
P56	Coming soon								
P63	140	115	10	9	110 f7	4	11 E7	12.8	4 H9
P71	160	130	10	9	110 f7	4	14 E7	16.3	5 H9
P80	200	165	12	10.5	130 f7	4.5	19 E7	21.8	6 H9
P90	200	165	12	10.5	130 f7	4.5	24 E7	27.3	8 H9
P100	250	215	15	13	180 f7	4.5	28 E7	31.3	8 H9
P112	250	215	15	13	180 f7	4.5	28 E7	31.3	8 H9
P132	300	265	15	13	230 f7	4.5	38 E7	41.3	10 H9

it	CP07	CP17	CP37	CP47	CP57	CP67
	Coming soon					
	186	198	216	239		
	186	198	216	239		
	-	218	236	259		
	-	-	236	259		
	-	-	-	297		
	-	-	-	297		
	-	-	-	-		

NEMA Standard Flanges - Dimensions expressed in inches

	D3	D2	tf	dhf	D1	tf1	ds	hk	wk
Inch dimensions									
N56	6-1/2	5-7/8	1/32	0.472	4-1/2	0.197	5/8	45/64	3/16
N143	6-1/2	5-7/8	1/32	0.472	4-1/2	0.197	7/8	61/64	3/16
N145	6-1/2	5-7/8	1/32	0.472	4-1/2	0.197	7/8	61/64	3/16
N182	9	7-1/4	1/32	0.63	8-1/2	0.197	1-1/8	1-15/64	1/4
N184	9	7-1/4	1/32	0.63	8-1/2	0.197	1-1/8	1-15/64	1/4
N213	9	7-1/4	1/32	0.63	8-1/2	0.197	1-3/8	1-33/64	5/16
N215	9	7-1/4	1/32	0.63	8-1/2	0.197	1-3/8	1-33/64	5/16

it	CP07	CP17	CP37	CP47	CP57	CP67
	7362	7834	8543	9448		
	-	8582	9291	10196		
	-	-	9291	10196		
	-	-	-	11732		
	-	-	-	11732		
	-	-	-	-		
	-	-	-	-		

Solid input shaft

	ds	ls	hk	wk	lk
Metric dimensions					
HS1	16 h6	40	18	5 h9	32
HS2	19 h6	40	21.5	6 h9	32
HS3	24 h6	50	27	8 h9	40
Inch dimensions					
NHS1	5/8	1-9/16	23/32	3/16	1.26
NHS2	3/4	1-9/16	27/32	3/16	1.26
NHS3	7/8	2	31/32	3/16	1.575

it	CP07	CP17	CP37	CP47	CP57	CP67
	-	196	214	-		
	-	-	234	257		
	-	-	-	297		
	-	7716	8425	-		
	-	-	9192	10098		
	-	-	-	11.692		

If not specified, dimensions are expressed in mm

Option | EVOX Coaxial Gear Unit Side

Option List

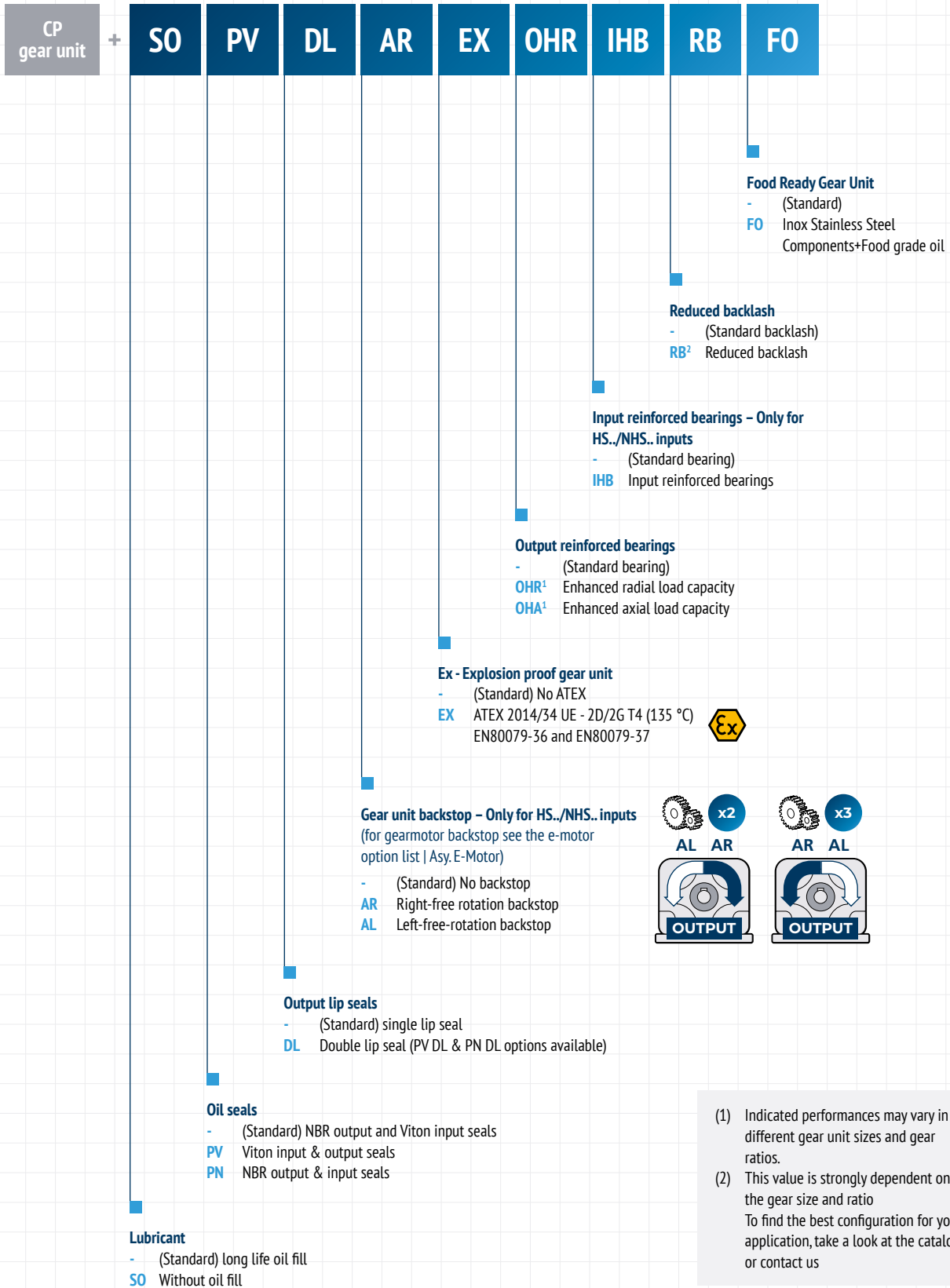

- (1) Indicated performances may vary in different gear unit sizes and gear ratios.
- (2) This value is strongly dependent on the gear size and ratio
To find the best configuration for your application, take a look at the catalog or contact us

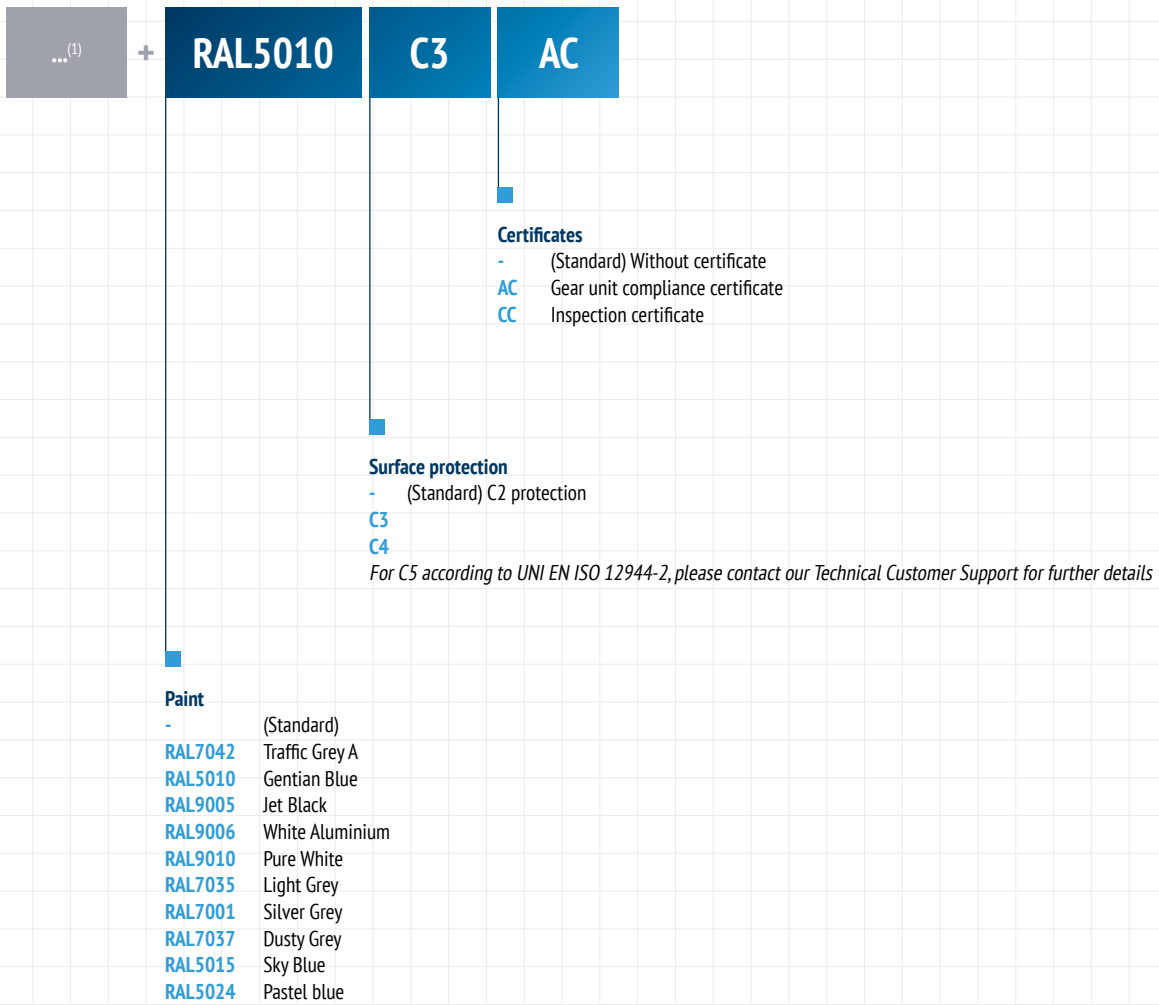

(1) Those options are available for Gear Units, Gearmotors, Gearbrakemotors, Stand alone motors and Stand alone Brakemotors

Option | EVOX Coaxial Gear Unit Side

Option List Deep Dive

Lubricant

Gear Units are supplied as standard with the correct amount of oil necessary in their lifetime.

SO

Without oil fill

With this option active, Gear Units are supplied without lubricant. See the [Lubricant Oil Table](#) to fill your gear unit with the correct lubricant according to the application's ambient conditions.

Oil seals

Gear Units are supplied as standard with a Viton Seal in input and a single lip NBR Seal in output.

Suggested versions:

Below -25°C
CTS

From -25°C to 0°C
Suggested PN

From 0°C to 3°C
Suggested standard

From 35°C to 60°C
Suggested PV

Over 60°C
CTS

CTS = [Contact Bonfiglioli's Technical Services.](#)

PV

Viton input and output seals

With this option active, Gear Units are supplied with Viton seals both in input and output.
Operative temperature range: min -25, max 160°C.

PN

NBR output & input seals

With this option active, Gear Units are supplied with NBR seals both in input and output.
Operative temperature range: min -40, max 100°C.

Output lip seals

Gear Units are supplied as standard with a single output lip seal, based on the previous option.

DL

Double lip seal

With this option active, Gear Units are supplied with a double lip NBR seal in output.
Select with this option also the "PV", if you want the double lip Viton seals in output.

Gear unit backstop – Only for HS./NHS.. inputs

Gear Units may be supplied with a backstop with HS input. For gearmotor backstops, see the [Motor Option List](#). Be mindful that the Clockwise [CW] and Counterclockwise [CCW] rotation option depends on the Gear Unit stage number.

AR/AL

Free right/left rotation backstop

Gear Units may be supplied with a backstop with HS input. For gearmotor backstops, see the [Motor Option List](#)

- **AR:** free right rotation
- **AL:** free left rotation

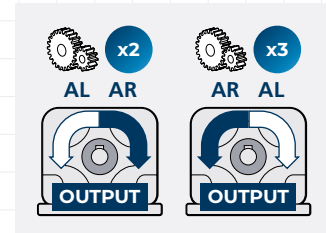

Output reinforced bearings

Gear Units are supplied with rough and reliable roller bearings from leading brands as standard; however, if your application requires higher performances, you can choose heavy duty bearings in output with these options.

In tables below, parameters are calculated with the following criterias:

- $[M_{n2}]$ torque applied on output shaft
- Worst Gear Unit rotating direction [CW or CCW]
- The radial force applied with the worst calculated

angle α for each gear ratio

- Radial load installed in the middle of the output shaft

The permitted radial loads can increase considerably when the parameters listed above vary. [Contact Bonfiglioli's Technical Service](#) if your application requires radial loads greater than the values indicated in the tables, because they may be available with a standard gear unit or with a simple option.

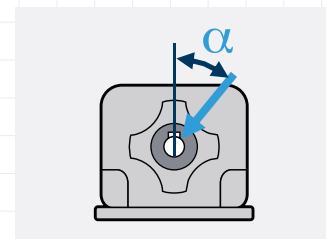

OHR

Enhanced radial load capacity

With those bearing, the radial loads at the gearbox output would be increased. This is the right solution for a belt and pulley or a chain-pinion transmission. Values listed below vary with Gear Ratio and calculating conditions. Please [contact Bonfiglioli's Technical Service](#) to select the right solution for you.

		CP07	CP17	CP37	CP47	CP57	CP67
Max permitted pure radial loads [kN]	Standard version	1.6	1.8	4.5	5.0	Coming Soon	
	OHR option	CTS	3.5	7.1	8.5		

CTS = [Contact Bonfiglioli's Technical Services](#).

OHA

Enhanced axial load capacity

With those bearing, the axial loads at the gearbox output would be increased. This is the right solution for axial pumps or screw conveyors. Values listed below vary with Gear Ratio and calculating conditions. Please [contact Bonfiglioli's Technical Service](#) to select the right solution for you.

		CP07	CP17	CP37	CP47	CP57	CP67
Max permitted pure Axial loads [kN]	OHA option			15.0	18.0	Coming Soon	

CTS = [Contact Bonfiglioli's Technical Services](#).

Option | EVOX Coaxial Gear Unit Side

Option List Deep Dive

Input reinforced bearings – Only for HS./NHS.. inputs

Gear Units are supplied with rough and reliable roller bearings from leading brands; however, if your application has different requirements, we can provide:

IHB

Compatibility: All sizes

With those bearing, the radial loads capacity in input of the gear unit could be enhanced. This is the right solution for a belt and pulley or a chain-pinion transmission. Please [contact Bonfiglioli's Technical Service](#) to select the right solution for you.

Reduced backlash

RB

Compatibility: All sizes

With this option active, Gear Units are supplied with a reduced angular backlash compared to the standard version.

Size	Standard backlash		Reduced backlash	
	2 stages	3 stages	2 stages	3 stages
07	11-18	20-25	7-12	10-16
17	11-18	20-25	7-12	10-16
37	11-18	20-25	7-12	10-16
47	11-18	20-25	7-12	10-16
57	Coming Soon			
67				

CTS = [Contact Bonfiglioli's Technical Services](#).

Value expressed in inch

Paint

Gearboxes with optional protection to class C3 or C4 are available in the colors listed in the following table.

Painting	Color	RAL number
RAL7042 *	Traffic Grey A	7042
RAL5010	Gentian Blue	5010
RAL9005	Jet Black	9005
RAL9006	White Aluminum	9006
RAL9010	Pure White	9010
RAL7035	Light Grey	7035
RAL7001	Silver Grey	7001
RAL7037	Dusty Grey	7037
RAL5015	Sky Blue	5015
RAL5024	Pastel blue	5024

* Gearboxes are supplied in this standard color if no other color is specified.

NOTE: "Paint" options can only be specified in conjunction with "Surface protection" options.

Surface protection

When no specific protection class is requested, the painted (ferrous) surface of the gearboxes is protected at least to corrosion class C2 (UNI EN ISO 12944-2). For improved resistance to atmospheric corrosion, gearboxes can be delivered with **C3** and **C4** surface protection, obtained by painting the entire gearbox.

Surface protection	Typical environments	Maximum surface temperature	Corrosion class according to UNI EN ISO 12944-2
C3	Urban and industrial environments with up to 100% relative humidity (medium air pollution)	120°C	C3
C4	Industrial areas, coastal areas, chemical plants, with up to 100% relative humidity (high air pollution)	120°C	C4

Gearboxes with optional protection class **C3** or **C4** are available in a choice of colors.

Gearboxes can also be supplied with surface protection for corrosion class **C5** according to UNI EN ISO 12944-2.

[Contact Bonfiglioli Technical Service](#) for further details.

Food-Ready Gear Unit

F0

Enhanced radial load capacity

With this shaft option, plugs, screws and nameplates are made of stainless steel (INOX). The gear unit is factory-filled with Klübersynth UH16-320. The oil pour point is -30°C and max temperature is 100°C.

Option | EVOX Coaxial Gear Unit Side

Option List Deep Dive



Explosion Proof Gear Unit

EX

ATEX 2014/34/ EU -2D/2G T4 (135 °C)

With this option active, the gear unit can be installed in Ex 1 and 21 areas (categories 2G and 2D). The temperature class is T4 (max 135°C).

To comply with this particular environment, Gear Units are equipped with:

- Service plugs for periodic lubricant level checks
- Factory-charged with lubricant (synthetic oil)
- Fluoro elastomer seal rings as standard
- Nameplate indication of the product category and type of protection
- Components that can operate above the max temperature indicated as a limit in the regulation
- Temperature indicator supplied with each unit

If the Gear Unit is equipped with the EX option, only 6 mounting positions are available. The unique oil level allows you to fit EVOX CP in any of the 6 standard positions with a single product code; however, any degree variation in both directions should be avoided, to observe the oil check plug position. Refer to the user manual at www.bonfiglioli.com for compliant maintenance procedures.

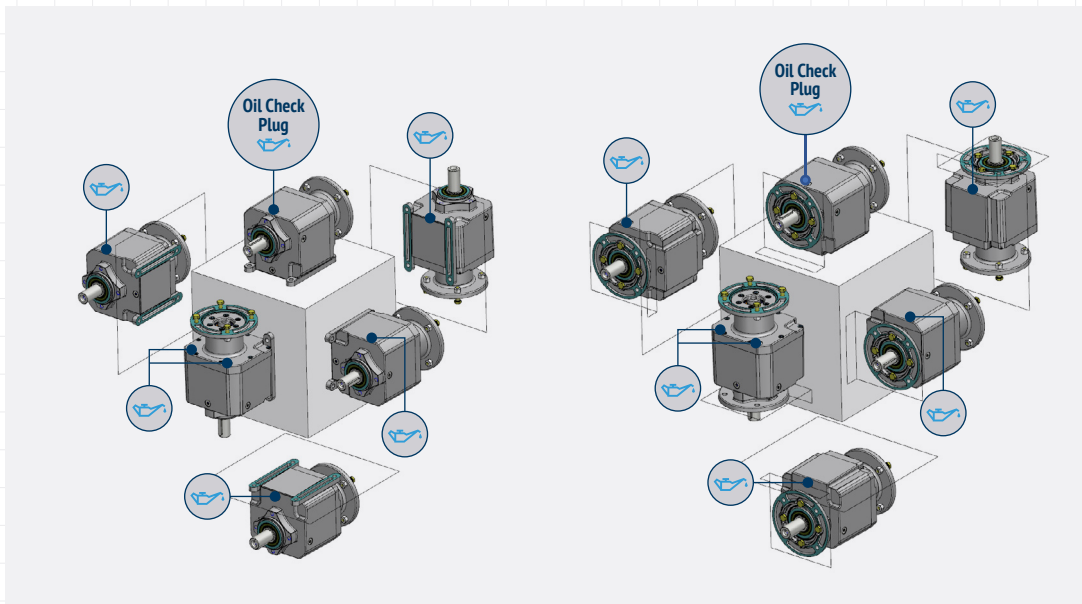

Oil quantity is the same as in the standard version, please see the [oil fill table](#) for further information.

Explosive atmosphere

An **explosive atmosphere**, for the purposes of Directive 2014/34/EU, is defined as a mixture:

- a. of **flammable substances**, in the form of gases, vapors, mists or dusts;
- b. with **air**;
- c. under atmospheric conditions;
- d. in which, after ignition, combustion spreads to the entire unburned mixture (sometimes, mainly with dust, the combustion does not consume the whole quantity of combustible material).

An atmosphere that could become explosive due to local and/or operational conditions is called a **potentially explosive atmosphere**.

Products falling under Directive 2014/34/EU are designed only for this kind of potentially explosive atmosphere.

European harmonized Atex standards

Directive 2014/34/EU establishes the minimum safety requirements for products intended for use in potentially explosive atmospheres, within the member countries of the European Union. The directive also divides such equipment into **categories** defined by the directive itself.

The following table describes the potentially explosive atmosphere **areas** where the equipment must be divided into different application categories.

Areas		Formation frequency of a potentially explosive atmosphere	Type of danger
Gaseous atmosphere	Dusty atmosphere		
G	D		
0	20	Present continuously or for long periods	Permanent
1	21	Likely to occur occasionally in normal operating conditions	Potential
2	22	Not likely to occur in normal operation, but if it does occur, will persist for short periods only	Minimal

BONFIGLIOLI RIDUTTORI gear units selected from this catalog are marked for installation in areas 1, 21, highlighted in light gray in the above diagram, and are also suitable for installation in areas with a lower level of protection (areas 2 and 22).

As of 20 April 2016, the ATEX Directive 2014/34/EU has been applied throughout the entire European Union, replacing any existing conflicting national and European laws on explosive atmospheres and previous Directive 94/9/EC.

It should be emphasized that, for the first time, the Directive also govern mechanical, hydraulic and pneumatic equipment, and not just electrical equipment as had been the case so far.

With regard to Machine Directive 2006/42/EC it should be noted that Directive 2014/34/EU is a set of extremely specific requirements describing the dangers resulting from potentially explosive atmospheres, whereas the Machine Directive contains only very general explosion safety requirements (Annex I).

Consequently, regarding the protection against explosion in potentially explosive atmospheres, Directive 2014/34/EU takes precedence over the Machine Directive.

The requirements of the Machine Directive apply to all other risks regarding machinery.

Option | EVOX Coaxial Gear Unit Side

Option List Deep Dive

Levels of protection for the various categories of equipment

The various categories of equipment must be able to operate in conformity with the Manufacturer's operational specifications, at certain defined levels of protection.

The availability of BONFIGLIOLI RIDUTTORI products is highlighted in gray.

Protection level	Category		Type of protection	Operating conditions
	Group I	Group II		
Very high	M1		Two independent means of protection or safety, capable of operating even when two independent faults occur.	The equipment remains powered and operational even in the presence of an explosive atmosphere.
Very high		1	Two independent means of protection or safety, capable of operating even when two independent faults occur.	The equipment remains powered and operational in areas 0, 1, 2 (G) and/or areas 20, 21, 22 (D).
High	M2		Protection suitable for normal operation and heavy duty conditions.	Power to the equipment is shut off in the presence of a potentially explosive atmosphere.
High		2	Protection suitable for normal operation and frequent faults or equipment in which malfunction is normal.	The equipment remains powered and operational in areas 1, 2 (G) and/or areas 21, 22 (D).
Normal		3	Protection suitable for normal operation.	The equipment remains powered and operational in areas 2 (G) and/or areas 22 (D).

Group definition

Group I Applies to equipment intended for use underground in parts of mines and those parts of surface installations of such mines, subject to being endangered by firedamp and/or combustible dust.

Group II Applies to equipment intended for use in other places, subject to being endangered by explosive atmospheres. BONFIGLIOLI RIDUTTORI products may not therefore be installed in mines, classified in **Group I** and in **Group II**, category 1. To summarize, the classification of equipment into groups, categories and areas is illustrated in the table below, whereby the availability of BONFIGLIOLI RIDUTTORI products is highlighted in gray.

Group	I Mines, firedamp		II Other potentially explosive areas (gas, dust)					
	M1	M2	1	2	3			
Atmosphere ⁽¹⁾			G	D	G	D	G	D
Areas			0	20	1	21	2	22
Type of protection gear unit					Ex h Gb	Ex h Db	Ex h Gc	Ex h Dc

⁽¹⁾ G = gas / D = dust

The products described herein conform to the minimum safety requirements of European Directive 2014/34/EU, which is part of the directives known as ATEX (ATmosphères EXplosibles).

Declaration of conformity

The Declaration of Conformity is the document that attests to the conformity of the product with Directive 2014/34/EU.

The validity of the Declaration is bound to observance of the instructions given in the User, Installation and Service Manual for safe use of the product throughout its service life on www.bonfiglioli.com.

The instructions regarding ambient conditions are of particular importance inasmuch as failure to observe them during operation of the product renders the certificate null and void. In case of doubt regarding the validity of the certificate of conformity, contact BONFIGLIOLI RIDUTTORI Technical Department.

EVOX Electric Motor



Product Overview

Bonfiglioli Portfolio

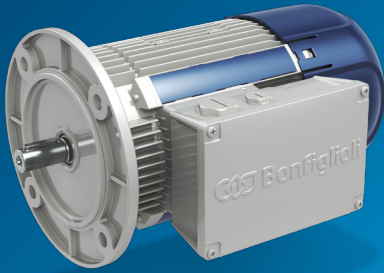

EVOX BXN, MXN and MNN are asynchronous low voltage (<1000V) e-motors and brakemotors, developed in the sign of modularity, efficiency and reliability.

The aim of this product is to be compliant with your needs, both in standalone version and in a compact coupling with Bonfiglioli Gear Units.

Efficiency	Compact		IEC	Power [kW]
	IE1/NEMA Standard	IE3/NEMA Premium	IE3/NEMA Premium	
Series	MNN	MXN	BXN	
Poles	4	4	4	
	05MA	05MA	63MA	0,12
	05MB	05MB	63MB	0,18
	05MC	10MA	71MA	0,25
	10MA			0,25
	10MB	10MB	71MB	0,37
	10MC	20MA	80MA	0,55
	20MA			0,55
	20MB	20MB	80MB	0,75
		25S	90S	1,1
		25L	90L	1,5
		30LA	100LA	2,2
		30LB	100LB	3
		35M	112M	3,7
		40S	132S	5,5
		40M	132M	7,5

Coming soon

The Motor and Inverter in Bonfiglioli History



In the 1990s, Bonfiglioli integrated its gear unit design within the portfolio and the know-how of an important local company, and started designing its own electric motors to create robust and efficient gearmotors.

Over the last years, Bonfiglioli has integrated its offering with servo and reluctance motors and, with the acquisition of Vectron in 2001, now it can design and manufacture also inverters, and it has become a **Solution Provider**.

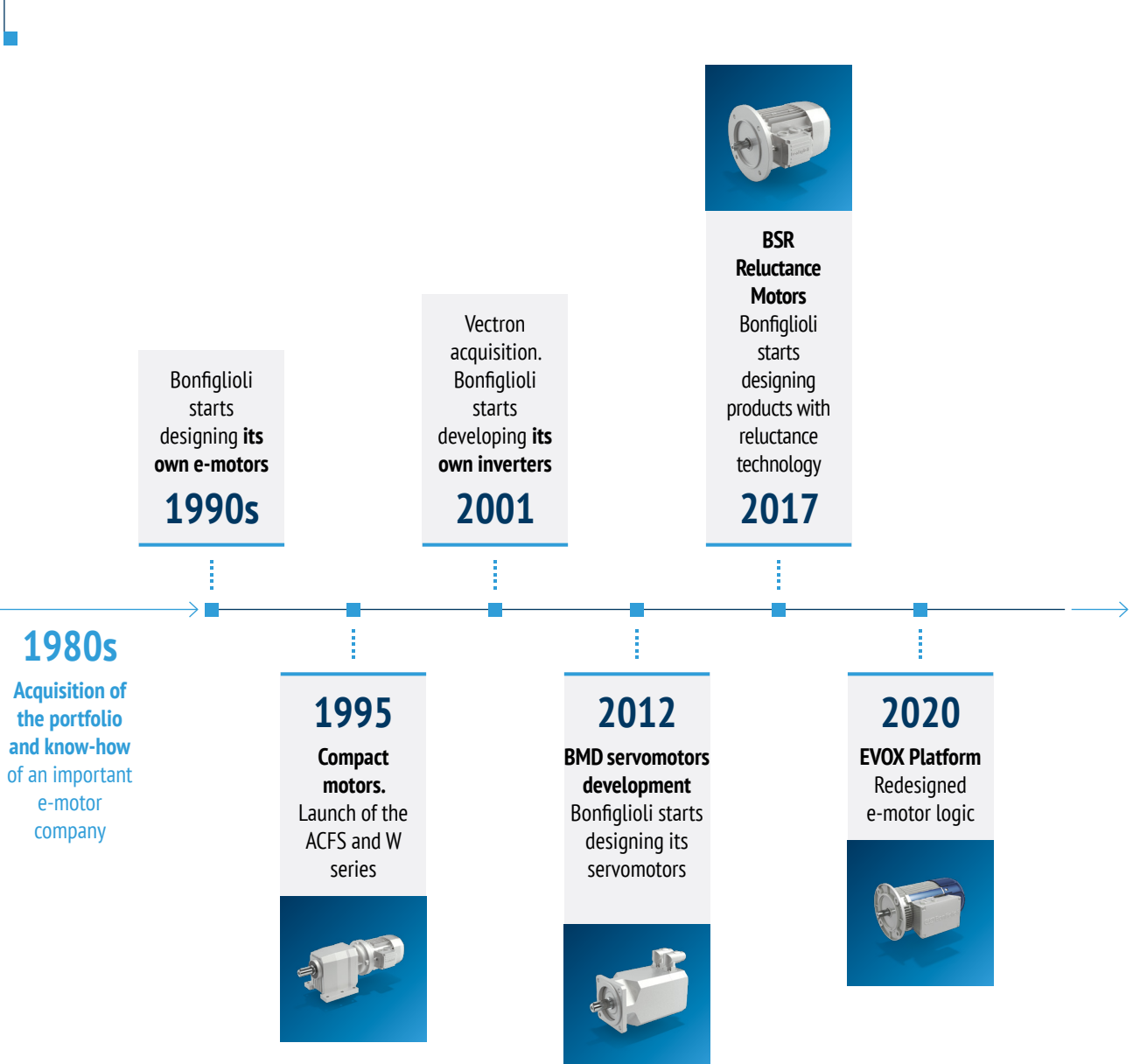

Product Overview

Bonfiglioli Portfolio

E-motor Offer

Bonfiglioli offers a great set of opportunities to match your application requirements around the world: you just need to choose your solution.

eVOX Gear Unit

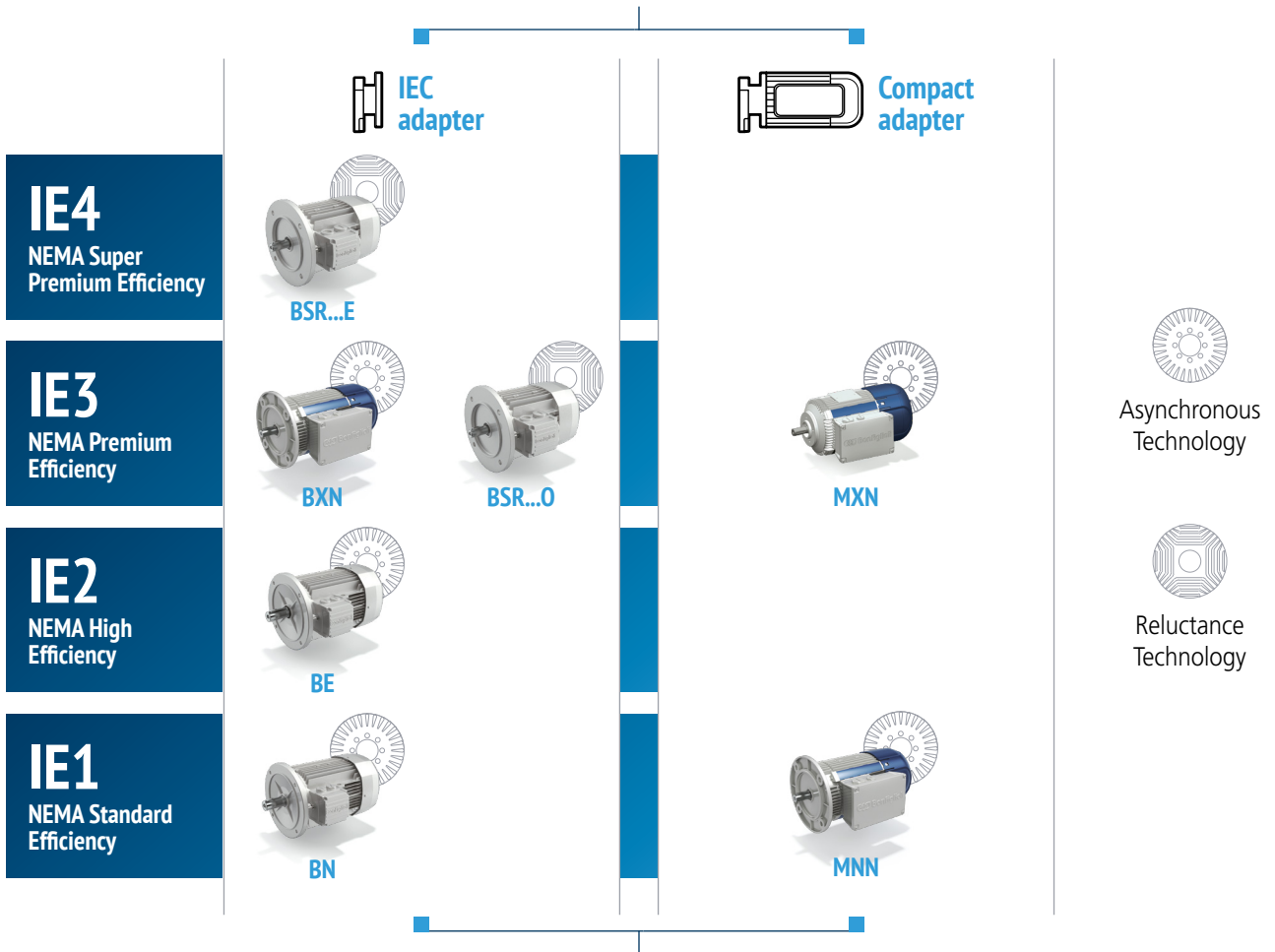

Complete your solution



Suitable applications

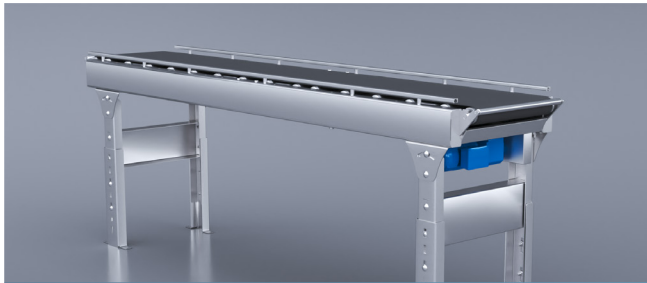

Smart conveyor



Features	Benefits
Advanced and accurate sensorless vector control providing high starting torque at low speed	Reducing current consumption at starting phase
Built-in PLC functions	Programming smart conveyor without PLC
Standby mode	Energy saving
Integrated monitoring tool	Inverter failure prevention and diagnostics analysis

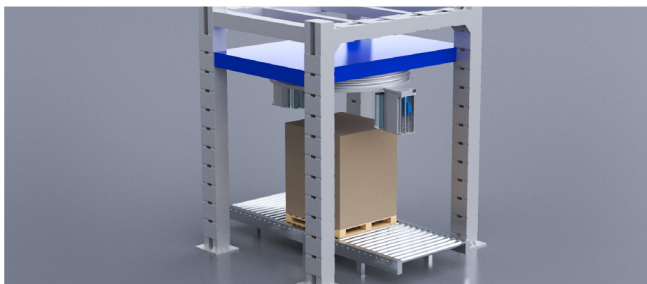

Wrapping machine



Features	Benefits
Advanced and accurate sensorless and closed loop vector control	Pallet wrapping machine soft start and soft stop
PI control with advanced derivative control	Optimized film tension control
Configurable position and speed control via parameters	Variable lift speed and up/down controls
Built-in PLC functions	Wrap cycle adjustment
Possible sync between several drives	Machine can operate without any PLC

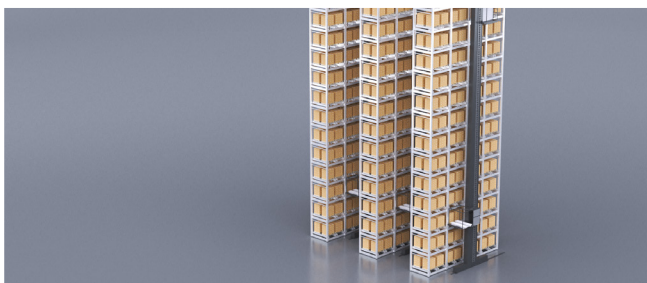

Vertical automatic storage



Features	Benefits
SBC (Safety Brake Control)	Minimized application risks
Sensor-connected ready	Scheduled maintenance-ready
See Bonfiglioli BMC  < Connectable with Motion Controller (CSP mode)	<ul style="list-style-type: none"> Machine complete integration One stop shop
All EVOX encoders are compatible with AxiaVert	Flexible application
iOS & Desktop user-friendly application and Bluetooth/Wi-Fi inverter connection	<ul style="list-style-type: none"> Plug & Play solution Easy troubleshooting

Product Overview

Standards & Directives

CE Mark on label

Motors are CE marked, that means they meet Directive LVD 2006/95/EC and Directive EMC 2004/108/EC. As for Directive EMC 2004/108/EC, it is also in accordance with CEI EN 60034-1, CEI EN 61000-6-1 and CEI EN 61000-6-3.

Motors with FD brakes, when fitted with the suitable capacitive filter at rectifier input (option CF), meet the emission limits required by Standards CEI EN 61000-6-3 and CEI EN 60204-1.

The responsibility for final product safety and compliance with applicable directives rests with the manufacturer or the assembler who incorporate the motors as component parts.

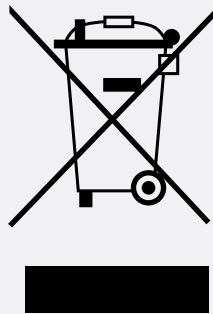

This product should not be mixed with general household waste.

Disposal has to be carried out in conformity with Directive 2012/19/EU, where established, and in accordance to national regulations.

They should be disposed of in accordance with any other legislation in force through the country.

National Standards

Motors are externally ventilated (IC 411) according to CEI EN 60034-6 and are equipped with a plastic fan cooling working in both directions.

Motors must be installed allowing access for maintenance purposes on motor and brake, if supplied.

For other cooling devices, please see the options section in this catalog.

Noise

Noise levels, measured using ISO 1680, within the maximum levels specified in CEI EN 60034-9.

Vibration balancing

Rotor shaft are balanced with half key fitted, and fall within vibration class N, as CEI EN 60034-14.

Configuration

Duty Cycle

Unless specified, catalog motor power refers to continuous duty S1. Any different condition has to be classified in the correct Duty Cycle, according with CEI EN 60034-1.

S2 Duty Cycle (Limited duration duty)

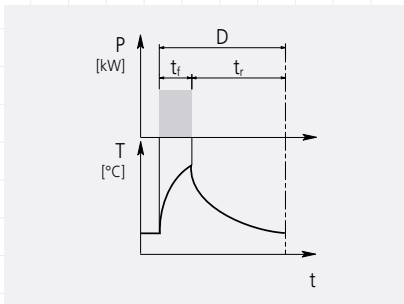

This type of duty is characterized by operation at a constant load for a limited time [t_f], which is shorter than the time required to reach thermal balance, followed by an idle period [t_r] where the motor can return to the ambient temperature.

The duration of the duty cycle is: $D=t_f+t_r$

t_f = work time under constant load

t_r = idle period

S3 Duty Cycle (Periodical intermittent duty)

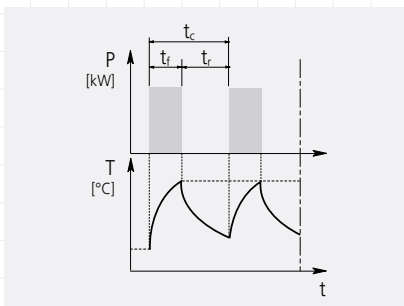

This type of duty is characterized by a sequence of identical operation cycles formed by a constant load operation and an idle period.

For this type of duty, the starting current does not significantly affect overtemperature.

t_f = work time under constant load

t_r = idle period

t_c = cycle time

$$I = \frac{t_f}{t_f + t_r} \cdot 100$$

t_f = work time under constant load

t_r = idle period

For a S2 & S3 duty cycle motor, the required motor power should be multiplied by the coefficient reported in the following table.

	Type of duty						
	S2			S3			S4 - S9
	D (min)			Intermittance (I)			
	10	30	60	25%	40%	70%	Contact us
f_m	1.35	1.15	1.05	1.25	1.15	1.1	

If cycles from S2 to S9 are chosen, the motor nameplate will be marked with the cycle name, an increased power rating and electrical data to suit the type of duty.

For further details, please contact [Bonfiglioli's Technical Service](#)

Configuration

Ambient temperature and altitude

Rating values are calculated for standard environmental conditions (40°C; altitude < 1000m a.s.l.) as specified in CEI EN 60034-1.

Motors can be used within the temperature range of -25°C and +60°C as standard. For temperature higher than 40°C the rated power output should be adjusted by factors given in the table below.

Ambient temperature (°C)	-25°C ≤ T < 40	40°	45°	50°	55°	60°
kft coefficient		100%	95%	90%	85%	80%

$$\text{Permitted power} = Pn_1 \cdot k_{ft} \cdot f_m$$

In cases in which the combination of the adjusting factors decreases the motor rated power by more than 15%, please [contact Bonfiglioli Technical Service](#).

e.g.

1) (S3 Duty cycle with I = 70%, $f_m = 1.1$), (T=60°C, $k_{ft} = 0.8$) = $1.1 \cdot 0.8 = 0.88$ -> OK

2) (S2 Duty cycle with D = 60min, $f_m = 1.05$), (T=60°C, $k_{ft} = 0.8$) = $1.05 \cdot 0.8 = 0.84$ -> [Contact Bonfiglioli Technical Service](#)

Product Modularity



Lots of e-motor versions available to perfectly match your application needs.

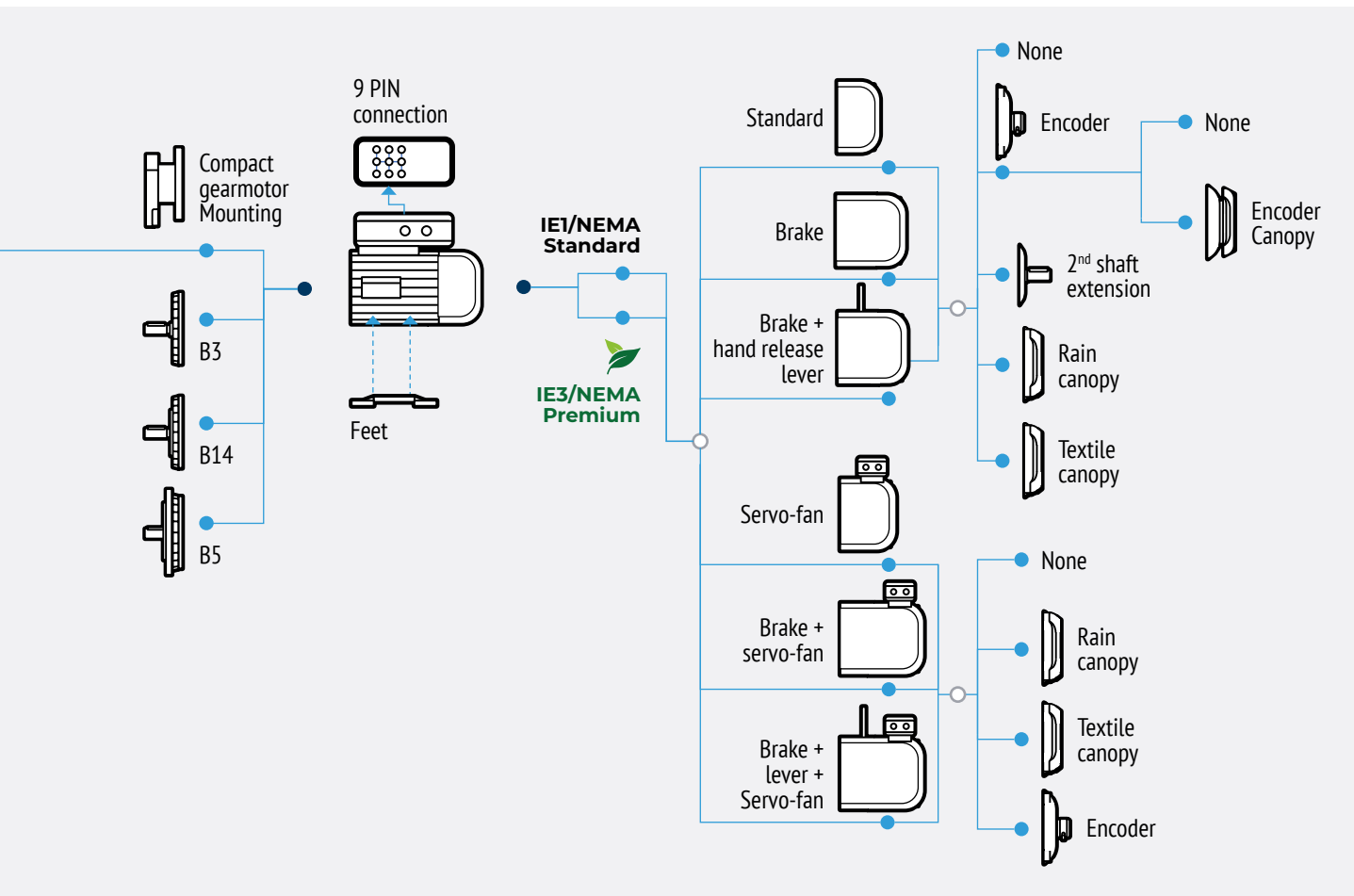

AC and DC brake are available.

Configuration

Designation

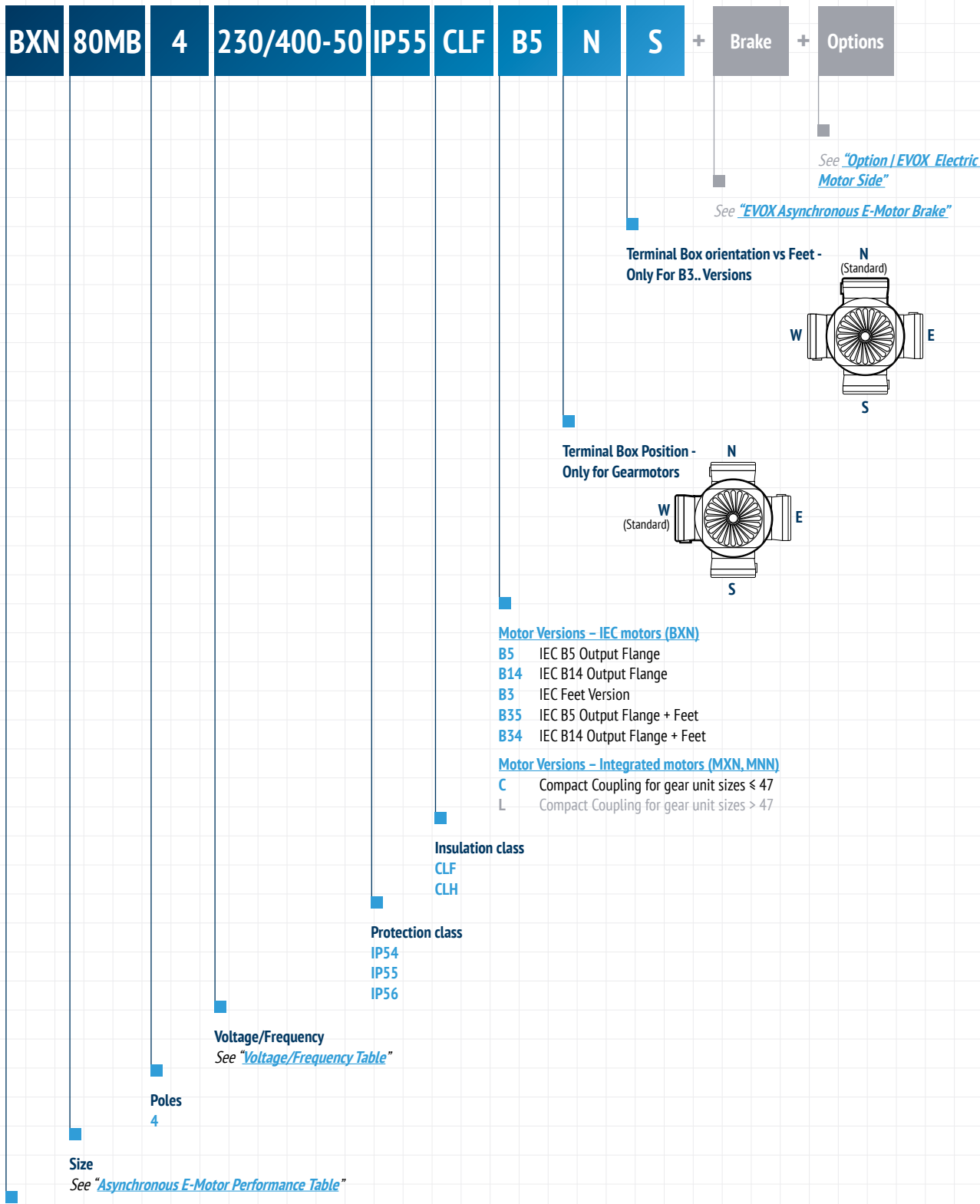

Asynchronous E-motor series

- BXN** Stand alone motor IE3/NEMA Premium
- MXN** Integrated Motor IE3/NEMA Premium
- MNN** Integrated Motor IE1/NEMA Standard

Voltage/Frequency

Terminal box 9 PIN arrangement

Rotation is possible in both directions. If terminals U1, V1, and W1 are connected to line phases L1, L2 and L3, clockwise rotation (from drive end) is obtained. For counterclockwise rotation, switch two phases.

On all EVOX motors, the voltage tolerance is reduced to $\pm 5\%$. For out-of-tolerance operation, temperature may exceed the limit provided in the relevant insulation class by 10 K. The motors are suitable for operation on distribution European grid with voltage complying with Publication IEC 60038.

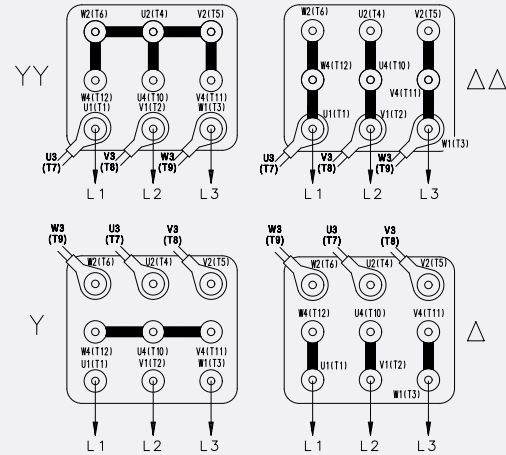

Motor sizes between IEC 63-112 or Compact 05-35

	Voltage
Winding 1	230/400V - 50Hz Δ/Y
	115/200V - 50Hz $\Delta\Delta/YY$
	230/460V - 60Hz YY/Y
	132/265V - 60Hz $\Delta\Delta/\Delta$
Winding 2	400/690V - 50Hz Δ/Y
	200/346V - 50Hz $\Delta\Delta/YY$
	230/400V - 60Hz $\Delta\Delta/YY$
	400/460V - 60Hz YY/Δ
Winding 3	220/380V - 50Hz Δ/Y
	110/190V - 50Hz $\Delta\Delta/YY$
	220/440V - 60Hz YY/Y
	127/255V - 60Hz $\Delta\Delta/\Delta$
Winding 4	190/330V - 50Hz Δ/Y
	95/165V - 50Hz $\Delta\Delta/YY$
	220/380V - 60Hz Δ/Y
	110/190V - 60Hz $\Delta\Delta/YY$
Winding 5	240/415V - 50Hz Δ/Y
	120/208V - 50Hz $\Delta\Delta/YY$
	280/480V - 60Hz Δ/Y
	140/240V - 60Hz $\Delta\Delta/YY$
Winding 6	415/720V - 50Hz Δ/Y
	208/360V - 50Hz $\Delta\Delta/YY$
	240/415V - 60Hz $\Delta\Delta/YY$
	415/480V - 60Hz YY/Δ
Winding 7	290/500V - 50Hz Δ/Y
	147/255V - 50Hz $\Delta\Delta/YY$
	330/575V - 60Hz Δ/Y
	165/290V - 60Hz $\Delta\Delta/YY$

Most used voltage/frequencies

Motor sizes above IEC 132 or Compact 40

	Voltage
Winding 1	400/690V - 50Hz Δ/Y
	200/346V - 50Hz $\Delta\Delta/YY$
	230/460V - 60Hz $\Delta\Delta/\Delta$
	230/400V - 60Hz $\Delta\Delta/YY$
Winding 2	230/400V - 50Hz $\Delta\Delta/YY$
	230/460V - 50Hz $\Delta\Delta/\Delta$
	265/460V - 60Hz $\Delta\Delta/YY$
	460/530V - 60Hz YY/Δ
Winding 3	220/380V - 50Hz $\Delta\Delta/YY$
	440/760V - 50Hz Δ/Y
	255/440V - 60Hz $\Delta\Delta/YY$
	440/510V - 60Hz YY/Δ
Winding 4	380/660V - 50Hz Δ/Y
	190/330V - 50Hz $\Delta\Delta/YY$
	220/380V - 60Hz $\Delta\Delta/YY$
	440/760V - 60Hz Δ/Y
Winding 5	240/415V - 50Hz $\Delta\Delta/YY$
	240/480V - 50Hz $\Delta\Delta/\Delta$
	280/480V - 60Hz $\Delta\Delta/YY$
	480/550V - 60Hz YY/Δ
Winding 6	415/720V - 50Hz Δ/Y
	208/360V - 50Hz $\Delta\Delta/YY$
	240/480V - 60Hz $\Delta\Delta/\Delta$
	240/415V - 60Hz $\Delta\Delta/YY$
Winding 7	290/500V - 50Hz $\Delta\Delta/YY$
	500/575V - 50Hz YY/Δ
	330/575V - 60Hz $\Delta\Delta/YY$
	575/660V - 60Hz YY/Δ

Configuration

Nameplate

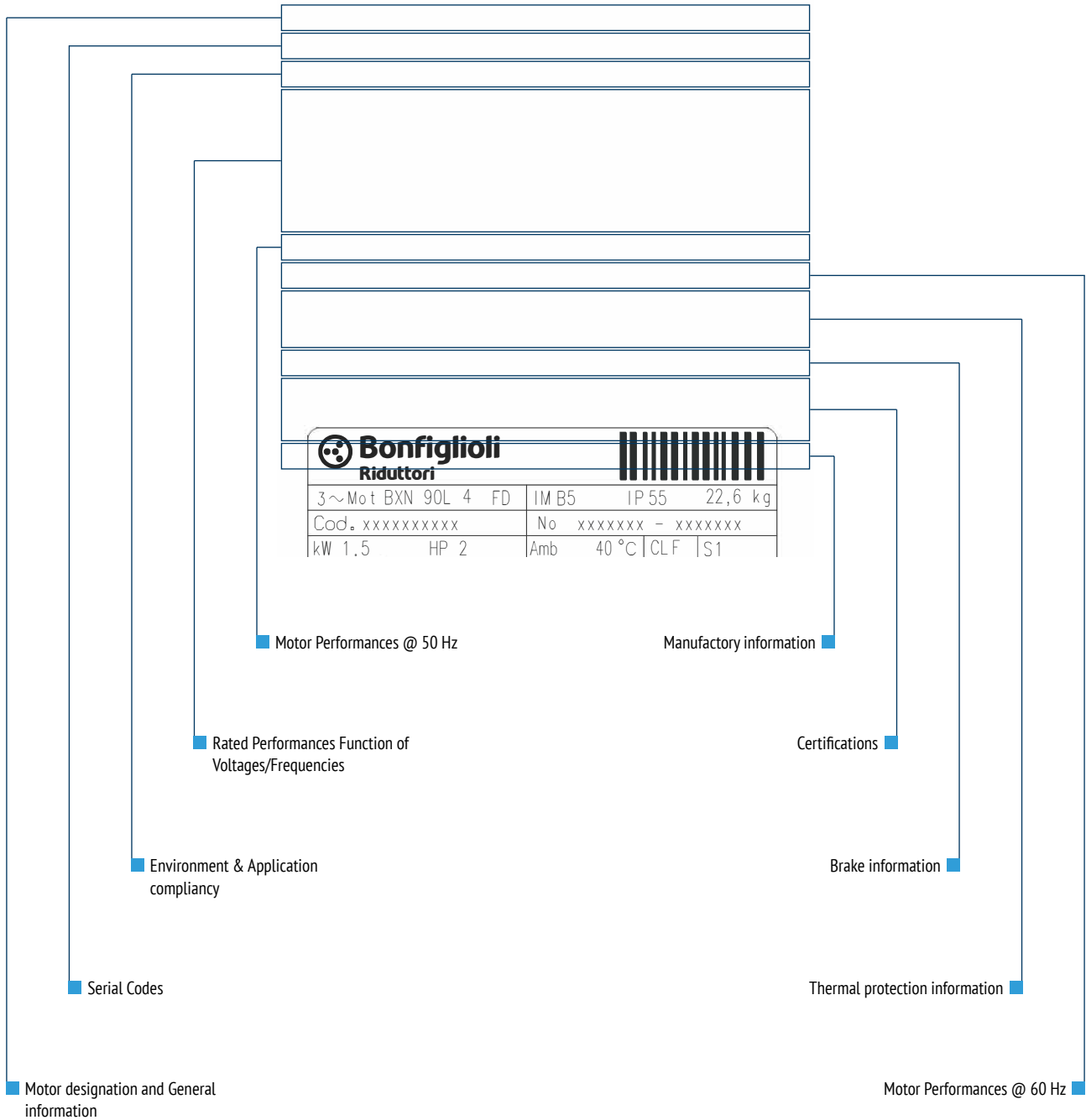

Protection class

IPxx

Index of protection

The IP – index of protection – shows the protection rate of the device from any external agents. It is composed of IP and 2 numbers, which show:

- the first digit describes the degree of protection rate against solid objects, dust, the solid particles and bodies.
- the second digit describes the degree of protection offered against liquids.

Solids Particles < 50 mm 1	Solids Particles < 12.5 mm 2	Solids Particles < 2.5 mm 3	Solids Particles < 1 mm 4	Solids Particles protected 5	Solids Particles tight 6		
Water Vertical dripping water 1	Water Dripping water < 15° 2	Water Spraying water 3	Water Splashing of water 4	Water Water jet 5	Water Pressure water jet 6	Water Immersion < 1 meter 7	Water Immersion ≥ 3 meters 8
Low level of protection			Standard level of protection		High level of protection		

Standard motors are designed to IP55 degree of protection and IP54 in case of brake motors. They can be installed in dusty or humid environments.

IP examples:

- IP54:
 - Protection against dust deposits
 - Protected against spray water
- IP55:
 - Protection against dust deposits
 - Protection against water jets from any direction
- IP56:
 - Protection against dust deposits
 - Protection against powerful water jets from any direction

Configuration

Insulation class

NEMA motor insulation classes describes the ability of motor insulation in the windings to handle heat (Ref. IEC 60085 and IEC 60034-1). There are four insulation classes in use namely: A, B, F, and H. All four classes identify the allowable temperature rise from an ambient temperature of 40° C (104° F). Classes B and F are the most common in many applications.

Temperature rise (T) and maximum temperatures at hot spots (Tmax) for insulation classes (IEC 60034-1).

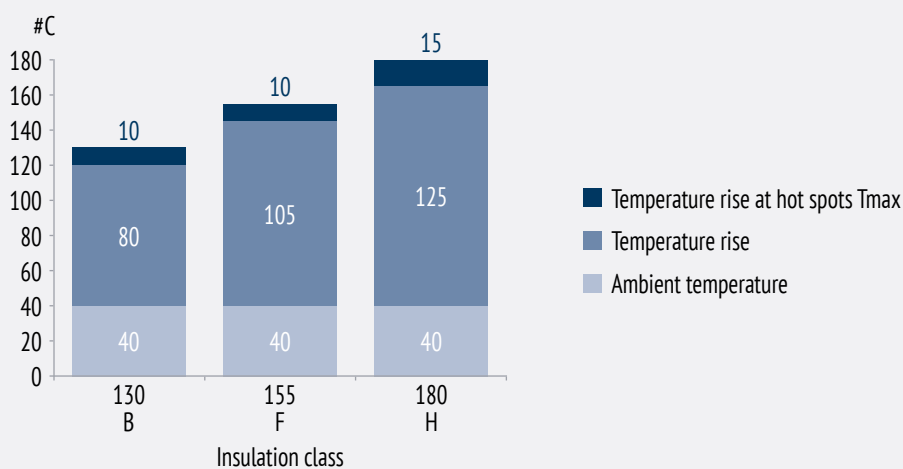

CLF

Class F insulation

The Bonfiglioli electric motors have been designed as standard with a class F insulation system (enamelled wire, insulators, impregnation resins). In standard motors, stator windings over temperature normally stays below the 80 K limit corresponding to class B over temperature. Class F allows for temperature rises of 105K (measured by the resistance variation method) and maximum temperatures at the hot spots in the motor of 155°C.

A careful selection of insulating components makes the motors compatible with tropical climates and normal vibration. For applications involving the presence of aggressive chemicals or high humidity, contact Bonfiglioli Engineering for assistance with product selection.

CLH

Class H insulation

Motors manufactured in insulation class H are available at request. This option fits for special constructions, where the necessary winding is class H and impregnated with special varnishes which enable it to operate in conditions of high temperatures with relative air humidity of up to 100%.

Versions

Motor Versions – IEC motors (BXN)

BXN motors are available in the design versions as indicated in the table below as per Standards EN 60034-7. Motor reporting on nameplate the standard mounting position can be mounted in the position illustrated in the following table:

B3

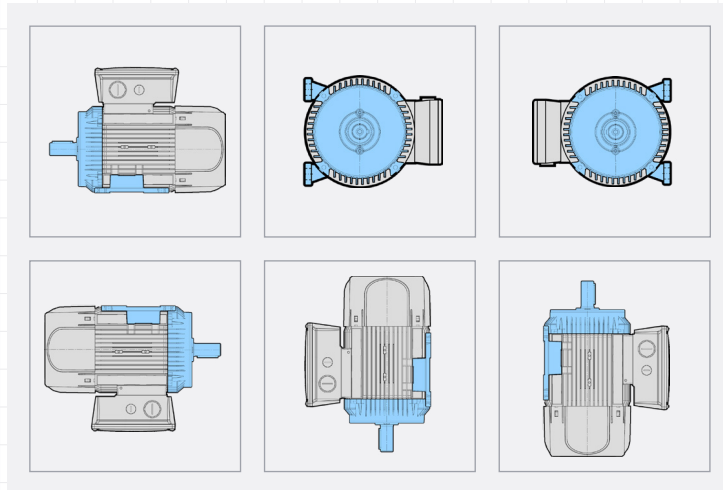

B5

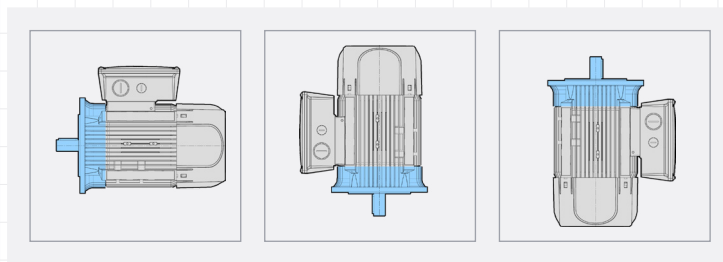

B14

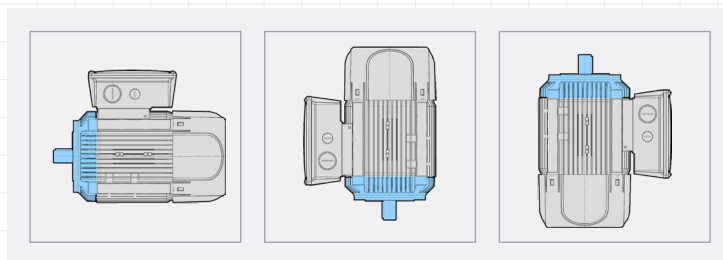

B3 mounting can be combined with B5 or B14 thus becoming B35 in the first case and B34 in the second one. For outdoor applications where the motor is mounted with the output shaft facing downwards, the selection of rain canopy (RC) option is recommended. This has to be specified during the ordering phase, because it is not present in standard motor versions.

Motor Versions – Integrated motors (MXN, MNN)

In case a compact motors of the EVOX platform (MXN and MNN) is configured as a stand alone product, please refer to the following list:

- C flanges: gear unit size ≤ 47
- L flanges: gear unit size > 47

Performance

EVOX E-Motor

Tables introduction

Motor designation		Output power		Output speed	Inertia	η			Torque			Weight
IEC	Compact	P_{n1}		n_1	$J \times 10^{-4}$	50%	75%	100%	T_N	T_S/T_N	T_A/T_N	(IEC B5 version)
		[kW]	[HP]	[rpm]	[kgm ²]	[%]	[%]	[%]	[Nm]	[Nm]	[Nm]	[kg]
BXN 63MA 4	MXN 05MA 4	0.12	0.16	1 407	1.82	52.5	60.3	64.8	0.8	2.9	1.7	4.6
BXN 63MB 4	MXN 05MB 4	0.18	0.25	1 373	2.92	63.3	68.8	69.9	1.3	3.1	1.8	5.7

■ Rated Voltage V_N

Motor designation		380 V				400 V				415 V			
IEC	Compact	Current		KVA	Code	Current		KVA	Code	Current		KVA	Code
		$\cos\phi$	I_N	I_S/I_N		$\cos\phi$	I_N	I_S/I_N		$\cos\phi$	I_N	I_S/I_N	
			[A]				[A]					[A]	
BXN 63MA 4	MXN 05MA 4	0.61	0.48	3.4	H	0.58	0.47	3.4	H	0.57	0.46	3.4	H
BXN 63MB 4	MXN 05MB 4	0.61	0.65	3.5	G	0.61	0.61	3.5	G	0.62	0.59	3.5	G

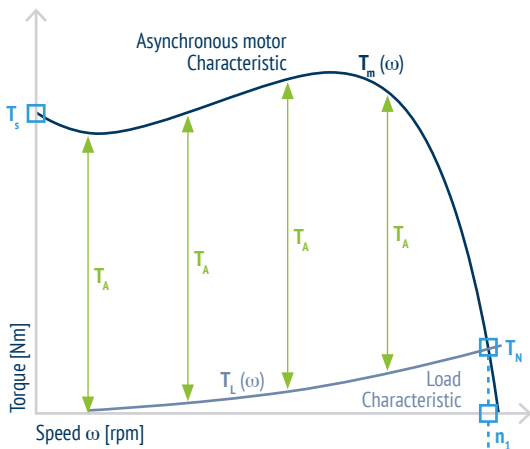

T_A = Acceleration torque

The T_A indicated in this catalogue is calculated with a finite element method because it is dependent from the Load Characteristic and the time.

$$T_A(t) = T_m(t) - T_L(t) = J \frac{\delta\omega}{\delta t}$$

(J is the motor + load inertia, both reduced at the output motor shaft)

T_A in this catalogue is calculated without a Load Characteristics and with only the EVOX motor inertia.

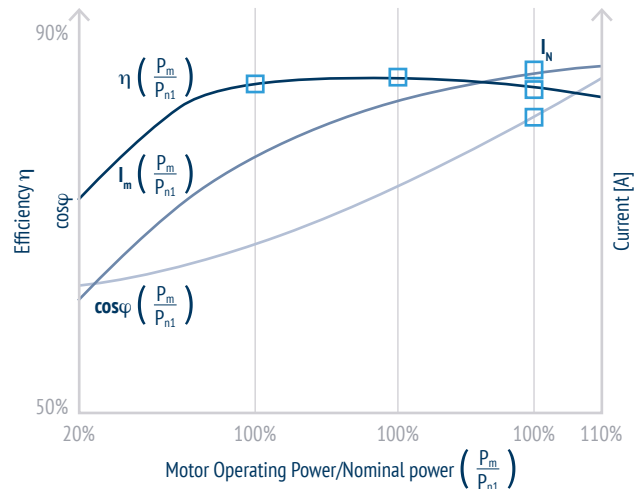
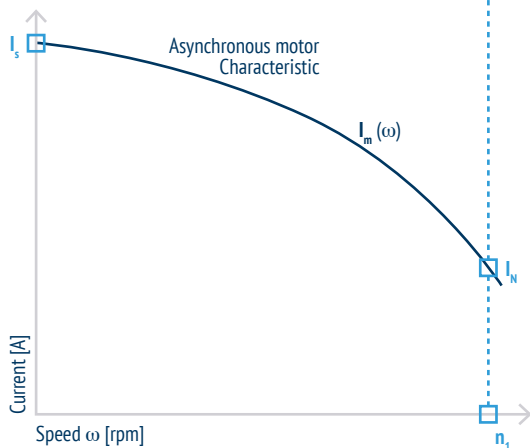

Please, refer to [Configuration Guidelines & Setup](#) section before the motor configuration, in order to select the correct Power

Tolerances

As per the Norms CEI EN 60034-1, applicable the tolerances here below apply to the following quantities.

Tolerance rule	Tolerance parameter
-0.15 (1 - η) P≤50kW	η
-(1 - cosφ)/6 min 0.02 max 0.07	cosφ
±20%*	Slip
+20%	I _s
-15% +25%	T _s
-10%	Max torque

(*) ≤30% for motors with P_n < 1kw

Code letters for locked-rotor KVA - Nameplate marking

KVA coefficient is a good solution to compare the inrush of different manufactures' motors than % inrush current. The reason being that if a motor has a high full load current, the % inrush will be lower than a motor with the same inrush current but a lower full load current.

Letter designation	KVA per horsepower*	Letter designation	KVA per horsepower*
A	0 - 3.15	L	9.0 - 10.0
B	3.15 - 3.55	M	10.0 - 11.2
C	3.55 - 4.0	N	11.2 - 12.5
D	4.0 - 4.5	P	12.5 - 14.0
E	4.5 - 5.0	R	14.0 - 16.0
F	5.0 - 5.6	S	16.0 - 18.0
G	5.6 - 6.3	T	18.0 - 20.0
H	6.3 - 7.1	U	20.0 - 22.4
J	7.1 - 8.0	V	22.4 and up
K	8.0 - 9.0		

(*) locked KVA per horsepower range includes the lower figure up to, but not including, the higher figure.

To determinate KVA per HP, use the following formula:

$$\frac{\text{KVA}}{P_{n1} \text{ [express in HP]}} \text{ where } \text{KVA} = V_n \cdot I_s \frac{\sqrt{3}}{1000}$$

EVOX E-Motor

Performance Table – 50Hz

IE3/NEMA Premium - 400 V - 50 Hz - 4 poles

Motor designation		Output power		Output speed	Inertia	η			Torque			Weight
IEC	Compact	P_{n1}		n_1	$J \times 10^{-4}$	50%	75%	100%	T_N	T_s/T_N	T_A/T_N	(IEC B5 version)
		[kW]	[HP]	[rpm]	[kgm ²]	[%]	[%]	[%]	[Nm]	[Nm]	[Nm]	[kg]
BXN 63MA 4	MXN 05MA 4	0.12	0.16	1 407	1.82	52.5	60.3	64.8	0.8	2.9	1.7	4.6
BXN 63MB 4	MXN 05MB 4	0.18	0.25	1 373	2.92	63.3	68.8	69.9	1.3	3.1	1.8	5.7
BXN 71MA 4	MXN 10MA 4	0.25	0.33	1 388	6.28	67.9	72.8	73.5	1.7	1.6	2.4	6.5
BXN 71MB 4	MXN 10MB 4	0.37	0.50	1 419	9.70	70.8	76.0	77.3	2.5	2.6	2.5	8.3
BXN 80MA 4	MXN 20MA 4	0.55	0.75	1 447	17.78	77.4	80.9	80.8	3.6	1.9	1.6	10.7
BXN 80MB 4	MXN 20MB 4	0.75	1.00	1 451	28.89	82.5	85.1	82.5	4.9	2.4	2.0	14.4
BXN 90S 4	MXN 25S 4	1.1	1.50	1 448	31.76	83.5	85.9	84.1	7.3	2.4	3.4	15.6
BXN 90L 4	MXN 25L 4	1.5	2.00	1 441	34.96	81.7	84.3	85.3	9.9	2.6	2.4	16.6

Motor designation		380 V				400 V				415 V			
IEC	Compact	Current			KVA	Current			KVA	Current			KVA
		$\cos\varphi$	IN	I_s/I_N	Code	$\cos\varphi$	IN	I_s/I_N	Code	$\cos\varphi$	IN	I_s/I_N	Code
			[A]				[A]				[A]		
BXN 63MA 4	MXN 05MA 4	0.61	0.48	3.4	H	0.58	0.47	3.4	H	0.57	0.46	3.4	H
BXN 63MB 4	MXN 05MB 4	0.61	0.65	3.5	G	0.61	0.61	3.5	G	0.62	0.59	3.5	G
BXN 71MA 4	MXN 10MA 4	0.73	0.71	4.8	H	0.74	0.67	4.8	H	0.73	0.65	4.8	H
BXN 71MB 4	MXN 10MB 4	0.65	1.12	6.3	L	0.66	1.05	6.3	L	0.63	1.06	6.3	L
BXN 80MA 4	MXN 20MA 4	0.73	1.40	6.1	J	0.75	1.31	6.1	J	0.73	1.29	6.1	J
BXN 80MB 4	MXN 20MB 4	0.78	1.71	7.4	K	0.78	1.63	7.4	K	0.79	1.56	7.4	K
BXN 90S 4	MXN 25S 4		2.51	7.3	J	0.78	2.38	7.3	J	0.77	1.33	7.3	J
BXN 90L 4	MXN 25L 4	0.75	3.59	6.7	J	0.75	3.44	6.7	J	0.75	3.31	6.7	J

IE1/NEMA Standard - 400 V - 50 Hz - 4 poles

Motor designation		Output power		Output speed	Inertia	η			Torque			Weight
IEC	Compact	P_{n1}		n_1	$J \times 10^{-4}$	50%	75%	100%	T_N	T_s/T_N	T_A/T_N	(IEC B5 version)
		[kW]	[HP]	[rpm]	[kgm ²]	[%]	[%]	[%]	[Nm]	[Nm]	[Nm]	[kg]
	MNN 05MA 4	0.12	0.16	1 362	1.45	52.0	60.2	50.0	0.8	1.9	1.3	4.2
	MNN 05MB 4	0.18	0.25	1 256	1.82	67.1	71.4	57.0	1.4	1.8	1.2	4.6
	MNN 05MC 4	0.25	0.33	1 317	2.92	60.4	65.5	61.5	1.8	2.6	1.4	5.7
	MNN 10MA 4	0.25	0.33	1 375	4.58	58.0	65.4	61.5	1.7	1.5	1.8	5.6
	MNN 10MB 4	0.37	0.50	1 368	6.28	65.4	70.8	66.0	2.6	1.5	1.6	6.5
	MNN 10MC 4	0.55	0.75	1 360	7.99	67.9	72.7	70.0	3.9	1.8	1.5	7.4
	MNN 20MA 4	0.6	0.75	1 423	12.23	70.3	74.9	70.0	3.7	1.3	1.0	8.8
	MNN 20MB 4	0.8	1.00	1 414	15.56	73.8	77.4	72.1	5.1	1.4	1.4	9.9

Motor designation		380 V				400 V				415 V			
IEC	Compact	Current			KVA	Current			KVA	Current			KVA
		$\cos\varphi$	IN	I_s/I_N	Code	$\cos\varphi$	IN	I_s/I_N	Code	$\cos\varphi$	IN	I_s/I_N	Code
			[A]				[A]				[A]		
	MNN 05MA 4	0.72	0.43	2.8	F	0.69	0.42	2.8	F	0.67	0.41	2.8	F
	MNN 05MB 4	0.78	0.64	2.4	D	0.75	0.62	2.4	D	0.75	0.60	2.4	D
	MNN 05MC 4	0.65	0.91	2.9	F	0.67	0.85	2.9	F	0.67	0.82	2.9	F
	MNN 10MA 4	0.73	0.78	3.9	G	0.70	0.77	3.9	G	0.69	0.75	3.9	G
	MNN 10MB 4	0.75	1.07	4.3	G	0.74	1.03	4.3	G	0.74	0.99	4.3	G
	MNN 10MC 4	0.75	1.57	4.3	G	0.75	1.49	4.3	G	0.75	1.44	4.3	G
	MNN 20MA 4	0.80	1.40	4.2	F	0.78	1.38	4.2	F	0.76	1.35	4.2	F
	MNN 20MB 4	0.79	1.89	4.5	F	0.80	1.77	4.5	F	0.78	1.74	4.5	F

Performance Table – 60Hz

IE3/NEMA Premium - 460 V - 60 Hz - 4 poles

Motor designation		Output power		Output speed	Inertia	η			Torque			Weight
IEC	Compact	P _{n1}		n ₁	J x10 ⁻⁴	50%	75%	100%	T _N	T _s /T _N	T _A /T _N	(IEC B5 version)
		[kW]	[HP]	[rpm]	[kgm ²]	[%]	[%]	[%]	[Nm]	[Nm]	[Nm]	[kg]
BXN 63MA 4	MXN 05MA 4	0.12	0.16	1 724	1.82	54.2	62.2	66.0	0.7	3.8	2.7	4.6
BXN 63MB 4	MXN 05MB 4	0.18	0.25	1 719	2.92	65.0	71.1	69.5	1.0	3.9	3.0	5.7
BXN 71MA 4	MXN 10MA 4	0.25	0.33	1 706	6.28	68.5	74.1	73.4	1.4	1.8	2.1	6.5
BXN 71MB 4	MXN 10MB 4	0.37	0.50	1 731	9.70	70.7	76.6	78.2	2.0	3.1	4.4	8.3
BXN 80MA 4	MXN 20MA 4	0.55	0.75	1 755	17.76	77.7	82.1	81.1	3.0	2.2	2.2	10.7
BXN 80MB 4	MXN 20MB 4	0.75	1.00	1 757	28.85	82.3	85.8	85.5	4.1	2.7	3.0	14.4
BXN 90S 4	MXN 25S 4	1.1	1.50	1 754	31.76	83.5	86.6	86.5	6.0	2.7	2.9	15.6
BXN 90L 4	MXN 25L 4	1.5	2.00	1 750	35.11	83.4	86.5	86.5	8.2	2.8	2.4	16.6

Motor designation		380 V				460 V				575 V			
IEC	Compact	Current			KVA	Current			KVA	Current			KVA
		cosφ	IN	I _s /I _N	Code	cosφ	IN	I _s /I _N	Code	cosφ	IN	I _s /I _N	Code
			[A]				[A]				[A]		
BXN 63MA 4	MXN 05MA 4	0.52	0.53	4.1	L	0.52	0.44	4.1	L	0.51	0.35	4.1	L
BXN 63MB 4	MXN 05MB 4	0.56	0.67	4.7	K	0.55	0.56	4.7	K	0.51	0.48	4.7	K
BXN 71MA 4	MXN 10MA 4	0.70	0.72	6.0	K	0.70	0.59	6.0	K	0.71	0.47	6.0	K
BXN 71MB 4	MXN 10MB 4	0.60	1.19	7.7	N	0.61	0.96	7.7	N	0.60	0.79	7.7	N
BXN 80MA 4	MXN 20MA 4	0.71	1.41	7.3	K	0.72	1.15	7.3	K	0.75	0.88	7.3	K
BXN 80MB 4	MXN 20MB 4	0.77	1.71	8.8	L	0.76	1.43	8.8	L	0.75	1.16	8.8	L
BXN 90S 4	MXN 25S 4	0.77	1.33	7.3	J	0.75	2.10	8.5	L	0.75	2.10	8.5	L
BXN 90L 4	MXN 25L 4	0.75	3.50	8.3	L	0.74	2.92	8.3	L	0.74	2.34	8.3	L

IE1/NEMA Standard - 460 V - 60 Hz - 4 poles

Motor designation		Output power		Output speed	Inertia	η			Torque			Weight
IEC	Compact	P _{n1}		n ₁	J x10 ⁻⁴	50%	75%	100%	T _N	T _s /T _N	T _A /T _N	(IEC B5 version)
		[kW]	[HP]	[rpm]	[kgm ²]	[%]	[%]	[%]	[Nm]	[Nm]	[Nm]	[kg]
	MNN 05MA 4	0.12	0.16	1 684	1.45	53.3	60.7	62.0	0.7	2.5	2.0	4.2
	MNN 05MB 4	0.18	0.25	1 658	1.82	59.3	65.6	66.0	1.0	2.3	1.8	4.6
	MNN 05MC 4	0.25	0.33	1 672	2.92	63.1	68.9	68.0	1.4	3.6	2.1	5.7
	MNN 10MA 4	0.25	0.33	1 696	4.58	59.6	67.0	68.0	1.4	1.8	2.8	5.6
	MNN 10MB 4	0.37	0.50	1 694	6.28	66.8	72.6	70.0	2.1	1.8	2.6	6.5
	MNN 10MC 4	0.55	0.75	1 689	7.99	70.5	75.4	74.0	3.1	2.2	2.4	7.4
	MNN 20MA 4	0.6	0.75	1 736	12.22	71.5	76.3	74.0	3.0	1.4	1.6	8.8
	MNN 20MB 4	0.8	1.00	1 730	15.56	75.6	79.5	77.0	4.1	1.7	1.6	9.9

Motor designation		380 V				460 V				575 V			
IEC	Compact	Current			KVA	Current			KVA	Current			KVA
		cosφ	IN	I _s /I _N	Code	cosφ	IN	I _s /I _N	Code	cosφ	IN	I _s /I _N	Code
			[A]				[A]				[A]		
	MNN 05MA 4	0.62	0.46	3.4	H	0.62	0.38	3.4	H	0.62	0.31	3.4	H
	MNN 05MB 4	0.68	0.62	3.3	F	0.67	0.51	3.3	F	0.67	0.41	3.3	F
	MNN 05MC 4	0.58	0.92	3.9	J	0.59	0.76	3.9	J	0.60	0.60	3.9	J
	MNN 10MA 4	0.65	0.84	4.8	J	0.66	0.68	4.8	J	0.66	0.55	4.8	J
	MNN 10MB 4	0.70	1.09	5.4	J	0.69	0.91	5.4	J	0.69	0.73	5.4	J
	MNN 10MC 4	0.70	1.58	5.6	J	0.69	1.31	5.6	J	0.67	1.08	5.6	J
	MNN 20MA 4	0.74	1.45	5.1	H	0.74	1.20	5.1	H	0.70	1.02	5.1	H
	MNN 20MB 4	0.76	1.87	5.5	H	0.77	1.54	5.5	H	0.80	1.19	5.5	H

Brake | EVOX Electric Motor

Product Overview

Asynchronous brake motors

Standard electric motors can be equipped with a brake thus creating a self-braking motor. The brake helps in situation where it is necessary a quickly and safely stop of the machine. The Bonfiglioli electric brakemotors incorporate a spring-applied electromagnetic brake which can be powered by a continuous (DC) or asynchronous (AC) power source.

All brakes are designed to provide fail-safe operation, meaning that they are applied by spring-action in the event of power failure.

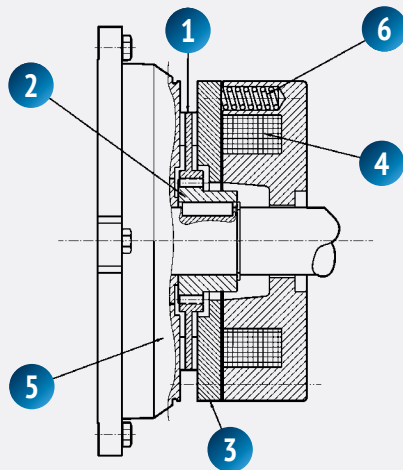

Key:

- 1 Brake disc
- 2 Disc carrier
- 3 Pressure plate
- 4 Brake coil
- 5 Motor rear shield
- 6 Brake springs

When voltage is interrupted, pressure springs push the reinforcement plate against the brake disc. The disc becomes trapped between the reinforcement plate and the motor shield and stops the shaft from rotating. When the coil is energized, a magnetic field strong enough to overcome the spring action attracts the reinforcement plate, so that the brake disc – which is integral with the motor shaft – is released.

Brake type selection

FA brakes [AC brake power supply]: they are suitable for applications where a fast reaction time and a quick stop is requested.

FD brakes [DC brake power supply]: they are suitable for applications where a smooth, progressive, silent and soft reaction time is requested.

Case	E-motor supply	Brake supply	Brake choices	Separate brake supply
1	AC	Connected on e-motor terminal box	FA FD + rectifier	-
2	AC	Dedicated AC	FA FD + rectifier	SA
3	AC	Dedicated DC	FD	SD

Bonfiglioli solution

Designation

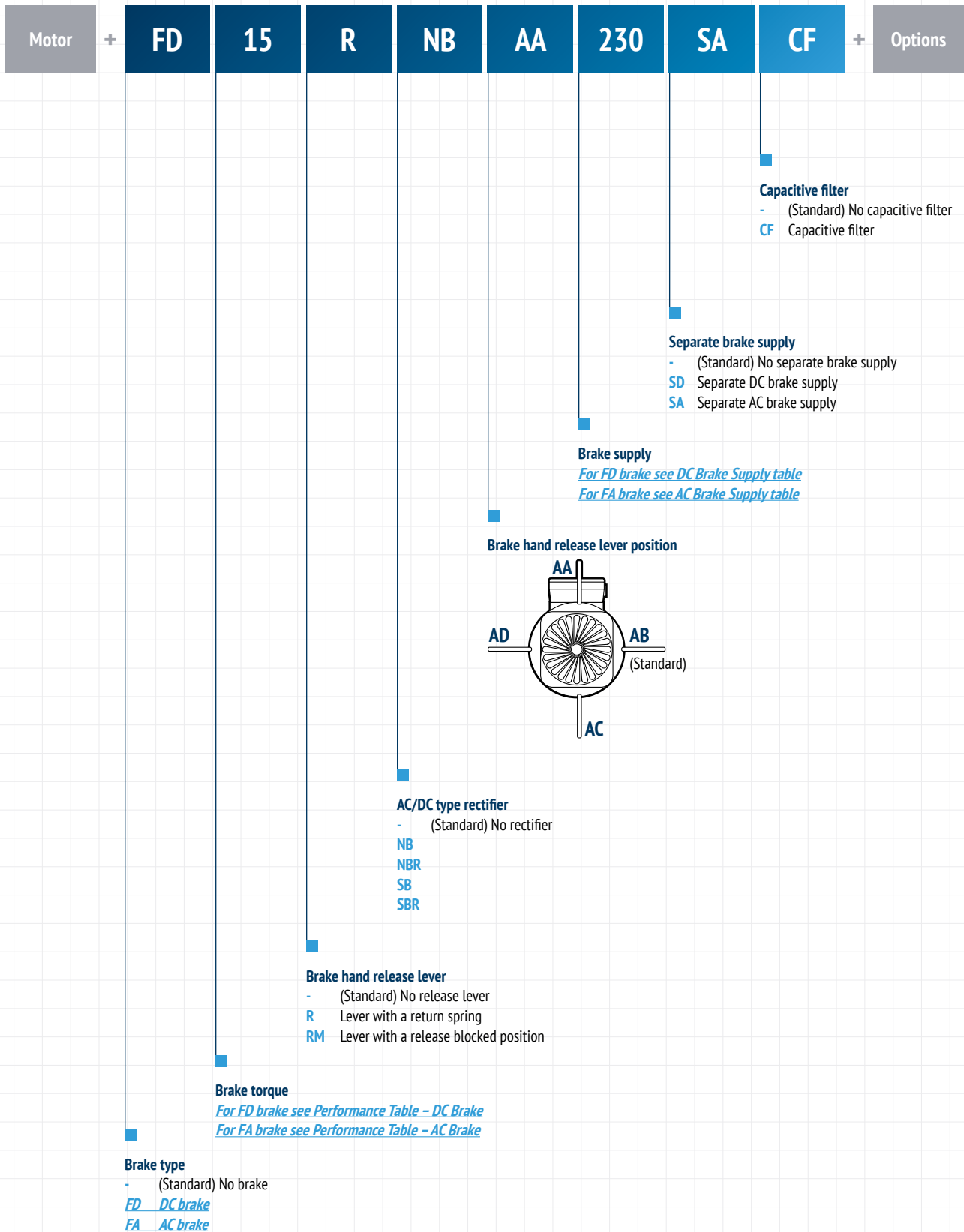



Brake | EVOX Electric Motor

Performance

Tables introduction

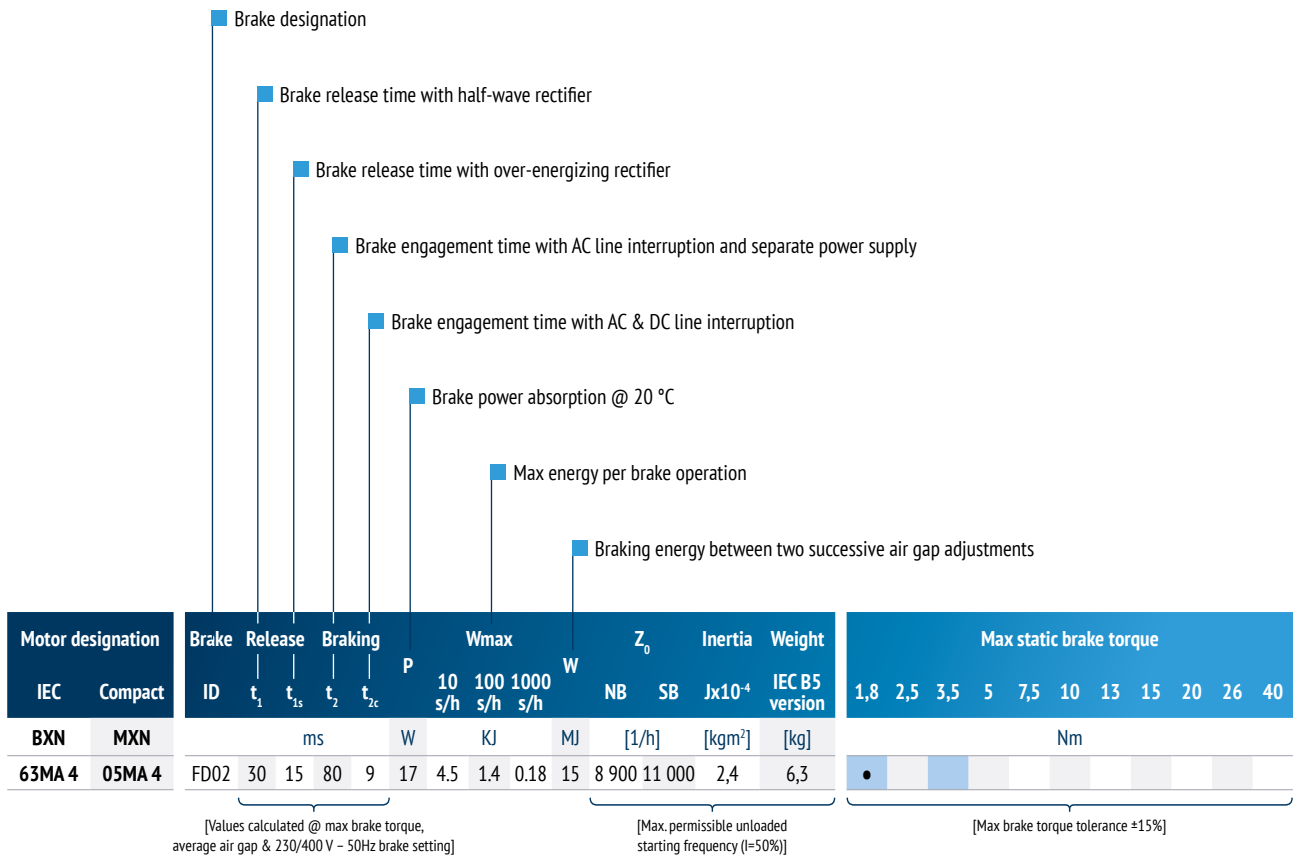

Brake | EVOX Electric Motor

Performance Table – DC Brake

Motor designation		Brake ID	Release				Braking				Wmax			Z ₀		Inertia	Weight	Max static brake torque									
IEC	Compact		t ₁	t _{1s}	t ₂	t _{2c}	P	10 s/h	100 s/h	1000 s/h	W	NB	SB	Jx10 ⁻⁴	IEC B5 version	1.8	2.5	3.5	5	7.5	10	13	15	20	26	40	
BXN	MXN	ms				W	KJ			MJ	[1/h]	[kgm ²]		[kg]	Nm												
63MA 4	05MA 4	FD02	30	15	80	9	17	4.5	1.4	0.18	15	8 900	11 000	2.4	6.3	•											
63MB 4	05MB 4	FD02	30	15	80	9	17	4.5	1.4	0.18	15	7 000	9 000	3.5	7.4		•										
71MA 4	10MA 4	FD53	60	30	100	12	24	7	1.9	0.23	25	5 700	8 100	7.4	9.2			•									
71MB 4	10MB 4	FD53	60	30	100	12	24	7	1.9	0.23	25	6 400	9 900	10.8	11.0			•									
80MA 4	20MA 4	FD04	80	35	140	15	33	10	3.1	0.35	30	2 500	5 200	19.8	14.6				•								
80MB 4	20MB 4	FD04	80	35	140	15	33	10	3.1	0.35	30	2 000	4 100	30.8	18.3					•							
90S 4	25S 4	FD05	130	65	170	20	45	18	4.5	0.5	50	2 800	6 600	35.8	21.6										•		
90L 4	25L 4	FD05	130	65	170	20	45	18	4.5	0.5	50	1 400	3 100	39.1	22.6										•		

Motor designation		Brake ID	Release				Braking				Wmax			Z ₀		Inertia	Weight	Max static brake torque									
IEC	Compact		t ₁	t _{1s}	t ₂	t _{2c}	P	10 s/h	100 s/h	1000 s/h	W	NB	SB	Jx10 ⁻⁴	IEC B5 version	1.8	2.5	3.5	5	7.5	10	13	15	20	26	40	
	MNN	ms				W	KJ			MJ	[1/h]	[kgm ²]		[kg]	Nm												
	05MA 4	FD02	30	15	80	9	17	4.5	1.4	0.18	15	8 000	10 000	2.1	5.9	•											
	05MB 4	FD02	30	15	80	9	17	4.5	1.4	0.18	15	6 400	8 200	2.4	6.3		•										
	05MC 4	FD02	30	15	80	9	17	4.5	1.4	0.18	15	5 700	7 300	3.5	7.4			•									
	10MA 4	FD53	60	30	100	12	24	7	1.9	0.23	25	9 900	14 000	5.7	8.3				•								
	10MB 4	FD53	60	30	100	12	24	7	1.9	0.23	25	5 600	8 800	7.4	9.2				•								
	10MC 4	FD53	60	30	100	12	24	7	1.9	0.23	25	3 300	6 700	9.1	10.1					•							
	20MA 4	FD04	80	35	140	15	33	10	3.1	0.35	30	2 600	5 300	14.2	12.7						•						
	20MB 4	FD04	80	35	140	15	33	10	3.1	0.35	30	1 900	3 900	17.6	13.8							•					

- DC brake torque
- Suggested torque

Performance Table – AC Brake

Motor designation		Brake ID	Release t_1	Braking t_2	P	Wmax			W	Z_0	Inertia $J \times 10^{-4}$	Weight IEC B5 version	Max static brake torque													
IEC	Compact					10 s/h	100 s/h	1000 s/h					W	Z_0	$J \times 10^{-4}$	IEC B5 version	1,8	2,5	3,5	5	7,5	10	13	15	20	26
BXN	MXN	ms			W	KJ				[1/h]	[kgm ²]	[kg]	Nm													
63MA 4	05MA 4	FA02	4	20	60	4.5	1.4	0.18	15	11 000	2.4	6.1	•													
63MB 4	05MB 4	FA02	4	20	60	4.5	1.4	0.18	15	9 000	3.5	7.2		•												
71MA 4	10MA 4	FA03	4	40	80	7	1.9	0.23	25	8 100	7.4	8.9			•											
71MB 4	10MB 4	FA03	4	40	80	7	1.9	0.23	25	9 900	10.8	10.7			•											
80MA 4	20MA 4	FA04	6	60	110	10	3.1	0.35	30	5 200	19.8	14.5				•										
80MB 4	20MB 4	FA04	6	60	110	10	3.1	0.35	30	4 100	30.8	18.2					•									
90S 4	25S 4	FA05	8	90	250	18	4.5	0.5	50	6 600	35.8	22.3											•			
90L 4	25L 4	FA05	8	90	250	18	4.5	0.5	50	3 100	39.1	23.3											•			

Motor designation		Brake ID	Release t_1	Braking t_2	P	Wmax			W	Z_0	Inertia $J \times 10^{-4}$	Weight IEC B5 version	Max static brake torque													
IEC	Compact					10 s/h	100 s/h	1000 s/h					W	Z_0	$J \times 10^{-4}$	IEC B5 version	1,8	2,5	3,5	5	7,5	10	13	15	20	26
	MNN	ms			W	KJ				[1/h]	[kgm ²]	[kg]	Nm													
	05MA 4	FA02	4	20	60	4.5	1.4	0.18	15	10 000	2.1	5.7	•													
	05MB 4	FA02	4	20	60	4.5	1.4	0.18	15	8 200	2.4	6.1		•												
	05MC 4	FA02	4	20	60	4.5	1.4	0.18	15	7 300	3.5	7.2		•												
	10MA 4	FA03	4	40	80	7	1.9	0.23	25	14 000	5.7	8.0			•											
	10MB 4	FA03	4	40	80	7	1.9	0.23	25	8 800	7.4	8.9			•											
	10MC 4	FA03	4	40	80	7	1.9	0.23	25	6 700	9.1	9.8				•										
	20MA 4	FA04	6	60	110	10	3.1	0.35	30	5 300	14.2	12.6					•									
	20MB 4	FA04	6	60	110	10	3.1	0.35	30	3 900	17.6	13.7						•								

- AC brake torque
- Suggested torque

Brake | EVOX Electric Motor

Options | Brake

Brake type

FD

DC brake type

Direct current toroidal-coil electromagnetic brake bolted onto the motor shield. Preloading springs provide axial positioning of magnet body. Brake disc slides axially on steel hub shrunk onto motor shaft with anti-vibration device. Brake torque factory setting is indicated in the corresponding motor rating charts. Braking torque may be modified by changing the type and/or number of springs. If requested, the motors may be equipped with a manual release lever with automatic return (R) or a system for holding the brake in the released position (RM). See variant in paragraph "BRAKE RELEASE SYSTEMS" for available release lever locations. FD brakes ensure excellent dynamic performance with low noise. DC brake operating characteristics may be optimized to meet the application requirements by choosing from the various rectifier/power supply and wiring connection options available.

For applications involving lifting and/or high hourly energy dissipation, contact Bonfiglioli's Technical Service.

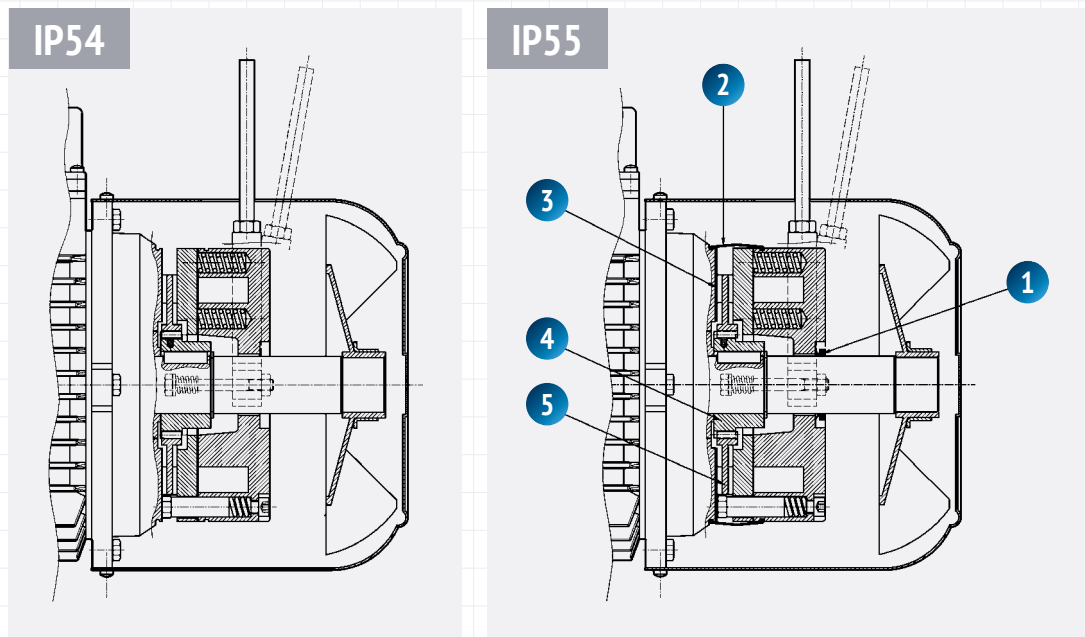

The standard protection degree for BN and $BX \leq 180$ is IP54, while for $BX \geq 200$ and $BX \geq 200K$ the standard protection degree is IP55.

BN and $BX \leq 180$ brakemotor with standard protection degree IP54 can be requested with a IP55 protection degree. If **IP55** is selected, the following construction variants will be applied:

- 1 V-ring at N.D.E. of motor shaft
- 2 Dust and waterproof rubber boot
- 3 Stainless steel ring placed between motor shield and brake disc
- 4 Stainless steel hub
- 5 Stainless steel brake disc

For FD technical specifications, refer to the performance section ([link](#))

FA

AC brake type

Electromagnetic brake operates from three-phase alternated current power supply and is bolted onto conveyor shield. Preloading springs provide axial positioning of magnet body.

Steel brake disc slides axially on steel hub shrunk onto motor shaft with anti-vibration device.

Brake torque factory setting is indicated in the corresponding motor rating charts.

Spring preloading screws provide stepless braking torque adjustment.

Torque adjustment range is $30\% M_{bMAX} < M_b < M_{bMAX}$ (where M_{bMAX} is maximum braking torque as shown in the tab).

Thanks to their high dynamic characteristics, FA brakes are ideal for heavy-duty applications as well as applications requiring frequent stops/starts and very fast response times.

If requested, the motors may be equipped with a manual release lever with automatic return (R). See variant in paragraph "BRAKE RELEASE SYSTEMS" for available release lever locations.

For applications involving lifting and/or high hourly energy dissipation, contact Bonfiglioli's Technical Service.

IP54

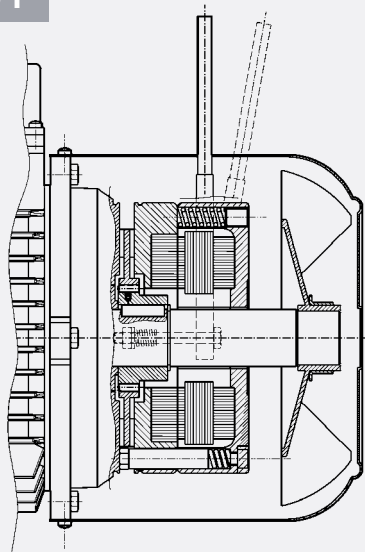

IP55

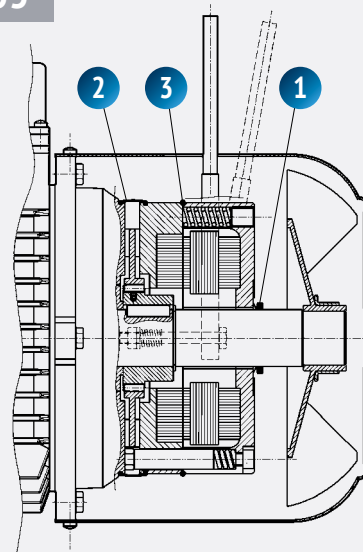

Standard protection class is IP54.

Brake motor FA is also available in protection class **IP55**, which mandates the following variants:

- 1 V-ring at N.D.E. of motor shaft
- 2 Dust and waterproof rubber boot
- 3 O-ring

For FA technical specifications please refer to the performance section ([link](#))

Brake | EVOX Electric Motor

Options | Brake

Brake hand release systems

Spring-applied brakes type FD and FA may be equipped with optional manual release devices. These are typically used for manually releasing the brake before servicing any machine or system parts operated by the motor.

Availability of the various disengagement devices is indicated below:

	R	RM
BXN_FD	BXN 63 ... BXN 90 BXN 100 ... BXN 132	BXN 63 ... BXN 90 BXN 100 ... BXN 132
BXN_FA	BXN 63 ... BXN 90 BXN 100 ... BXN 132	☐

R

Lever with return spring

With this options, the return spring brings the release lever back in the original position.

RM

Lever with a release blocked position

On brake motors type FD, if the RM option is specified, the release device may be locked in the "release" position by tightening the lever until its end becomes engaged with a brake housing projection.

Availability of the various disengagement devices is indicated below:

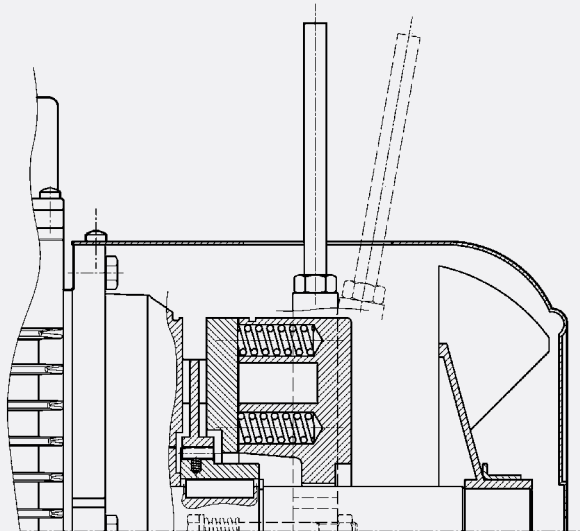

AC/DC rectifier type

The FD brake coil can be directly fed with DC current or by an AC/DC connection operated by a diode half-wave rectifier ($V_{DC} \approx 0,45 \times V_{AC}$). A rectifier is a circuit that converts the Alternating Current (AC) input power into a Direct Current (DC) output power. Evox products are available in versions NB and SB, as detailed in the table below:

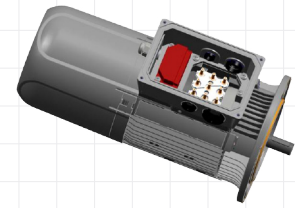

	Brake	Standard	At request
BXN 63	FD 02		
BXN 71	FD 03 - FD 53		
BXN 80	FD 04		
BXN 90S	FD 14		
BXN 90L	FD 05		
BXN 100	FD 15		
BXN 112	FD 06S		
BXN 132	FD 56 - FD 06 - FD 07		

(*) $t_{1c} < t_{1r} < t_2$

NB

Simple half-wave rectifiers

Rectifier **NB** lets just one half of each complete AC supply wave through, to transform it into a DC supply. The brake release response time is reduced.

SB

Double half-wave rectifiers:

Rectifier **SB** with electronic energizing control over-energizes the electromagnet upon power-up to cut brake release response times and then switches to normal half-wave operation once the brake has been released.

Use of the **SB** rectifier is mandatory in the event of:

- High number of operations per hour
- Reduced brake release response times
- Brake exposed to extreme thermal stress

Brake hand release lever position

AA

Release lever orientation

Unless otherwise specified, the release lever is located 90° away from the terminal box – identified by letters [AB] in the diagram on the right – in a clockwise direction on both R and RM options.

Alternative lever positions [AA], [AC] and [AD] are also possible when the corresponding option is specified.

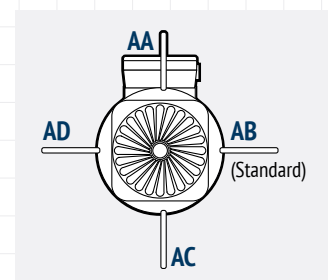

Brake | EVOX Electric Motor

Options | Brake

Brake supply

230

FD brake power supply

A rectifier installed inside the terminal box feeds the DC brake coil. Wiring connection across rectifier and brake coil is performed as factory standard.

On all single-pole motors, the rectifier is connected to the motor terminal board.

Brake power supply voltage is indicated in the following table, regardless of the mains frequency:

4P 	Motor power supply	Brake connected to terminal board power supply	Brake connected to a separate power supply		
			Voltage	FD SD	FD SA
BXN 63 ... BXN 90 BXN100 .. BXN 132	More options depending on the chosen winding and frequency	The brake works with the chosen winding configuration of the motor power supply. For more information please refer to the voltage and frequency section. In any case, you can find connection info on the terminal kit integrated in the motor.	24		
			48		
			56		
			74		
			90		
			100		
			110		
			115		
			120		
			127		
			132		
			150		
			165		
			180		
			200		
			208		
			220		
			230		
			240		
			330		
380					
400					
415					
440					
460					

Configurable for motors with 50Hz and 60Hz power supply

At request - Not configurable with power supply as standard

FD brake connection

For switch-pole motors, and where a separate brake power supply is required, connection to rectifier must comply with brake winding voltage stated in the motor nameplate.

Because of the inductive load type, brake control and DC line interruption must use contacts from usage class AC-3 to IEC 60947-4-1.

Table (1) – Brake coil with power supply from motor terminals, a.c. line interruption.

Table (2) – Brake coil with separate power supply, a.c. line interruption.

Table (3) – Brake coil with power supply from motor terminals, a.c. and d.c. lines interruption.

Table (4) – Brake coil with separate power supply, a.c. and d.c. lines interruption.

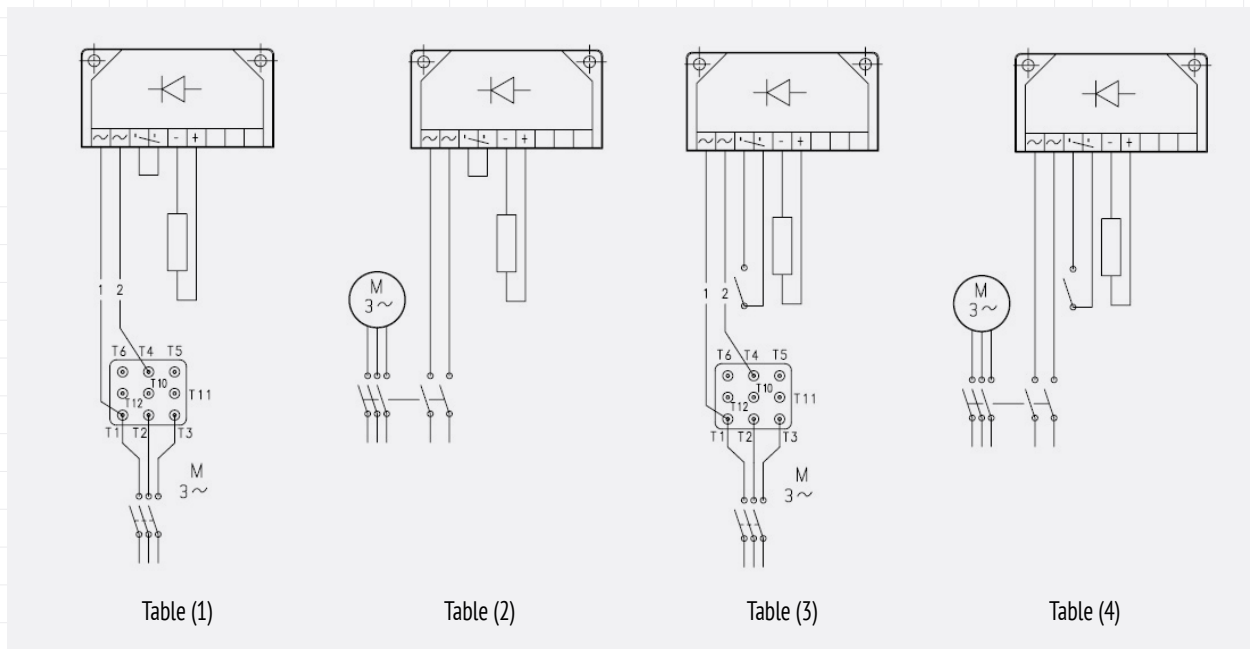

Brake connection when equipped with the CF option:

Motors with FD brake, when fitted with the suitable capacitive filter at rectifier input (option CF), meet the emission limits required by Standard EN 61000-6-3:

«Electromagnetic compatibility - Generic Emission Standard - Part 6.3: Residential, commercial and light industrial environments»

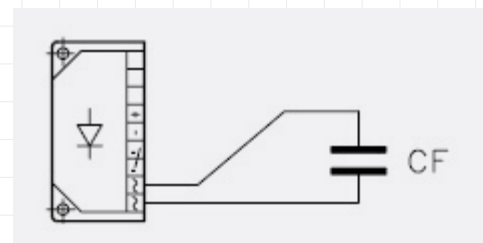

Brake | EVOX Electric Motor



Options | Brake

Brake supply

230

FA brake power supply

In single speed motors, power supply is brought to the brake coil directly from the motor terminal box. As a result, brake voltage and motor voltage are the same. In this case, brake voltage indication may be omitted in the designation. The following table reports standard AC brake power supply ratings for single pole motors:

4P		Motor power supply	Brake connected to terminal board power supply	Brake connected to a separate power supply	
				Voltage	FA SA
BXN 63 ... BXN 90 BXN100 .. BXN 132		More options depending on the chosen winding and frequency	The brake works with the chosen winding configuration of the motor power supply. For more information please refer to the voltage and frequency section. In any case, you can find connection info on the terminal kit integrated in the motor.	200	
				220	
				230	
				240	
				330	
				380	
				400	
				415	
				440	
				460	
				575	

- Configurable for motors with 50Hz and 60Hz power supply
- Configurable only for motors with 50Hz power supply (220/380-50, 230/400-50, 240/415-50, 400/690-50 and 415/720-50)
- Configurable only for motors with 60Hz power supply (220/380-60, 230/460-60 and 330/575-60)

FA brake connection

The diagram below shows the wiring when the brake is connected directly to same power supply of the motor:

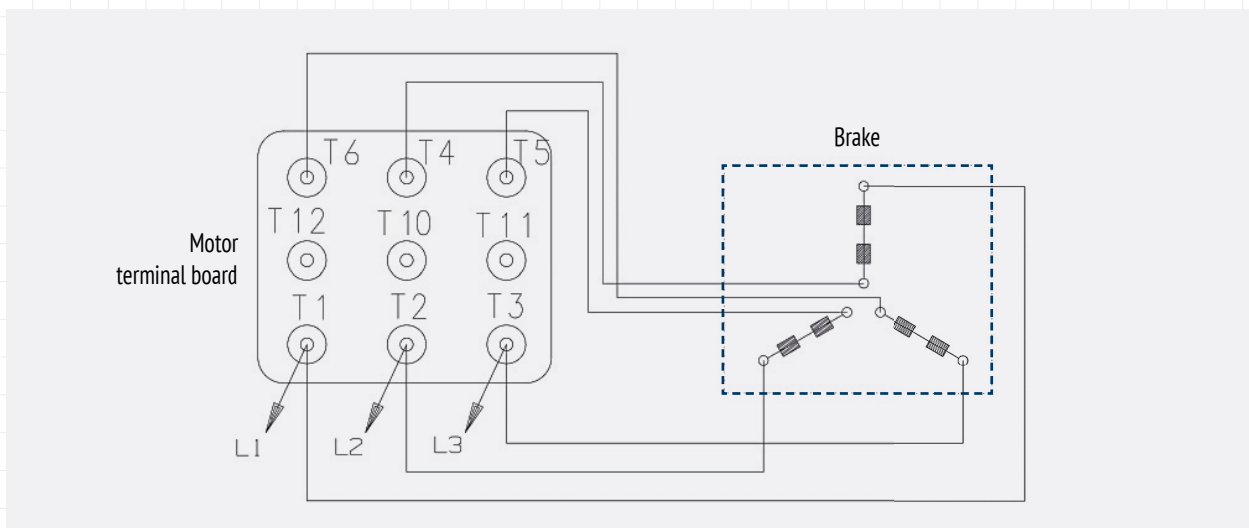

Switch-pole motors and, at request, single-pole motors with separate power supply are equipped with an auxiliary terminal board with 6 terminals for brake connections. In this version, the motors feature a larger terminal box. See diagram below.

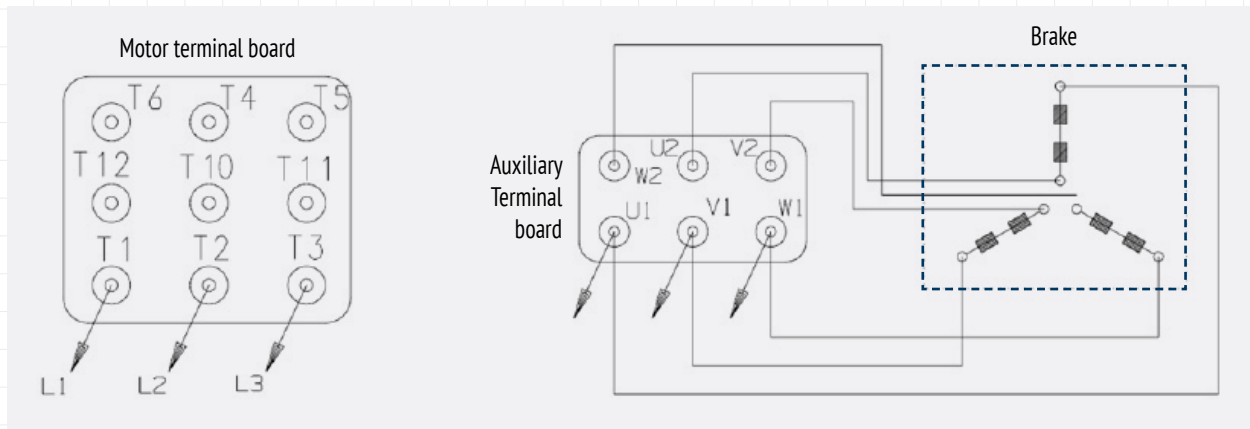

Separate brake supply

SD

Separate DC brake supply

The brake coil is directly fed with DC current and the rectifier is out of the scope of the supply. The rated coil voltage must be specified, e.g. 24SD.

SA

Separate AC brake supply

The brake coil is directly fed through an independent line, separately from the motor. In this case, the rated coil voltage must be specified, e.g. 230SA. The option is applicable to all motors with FD and FA brake type.

Options | EVOX Electric Motor Side

Option List

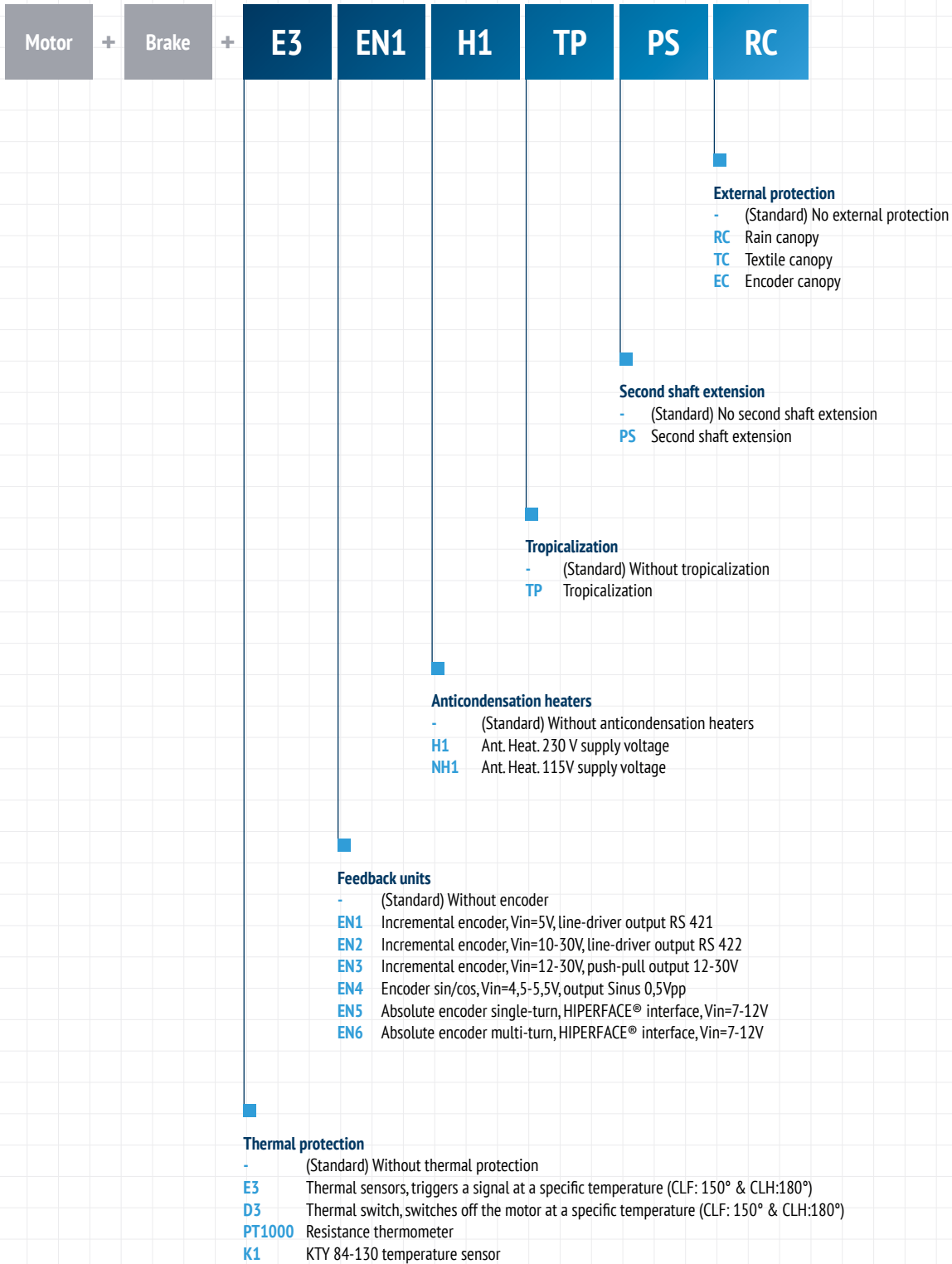

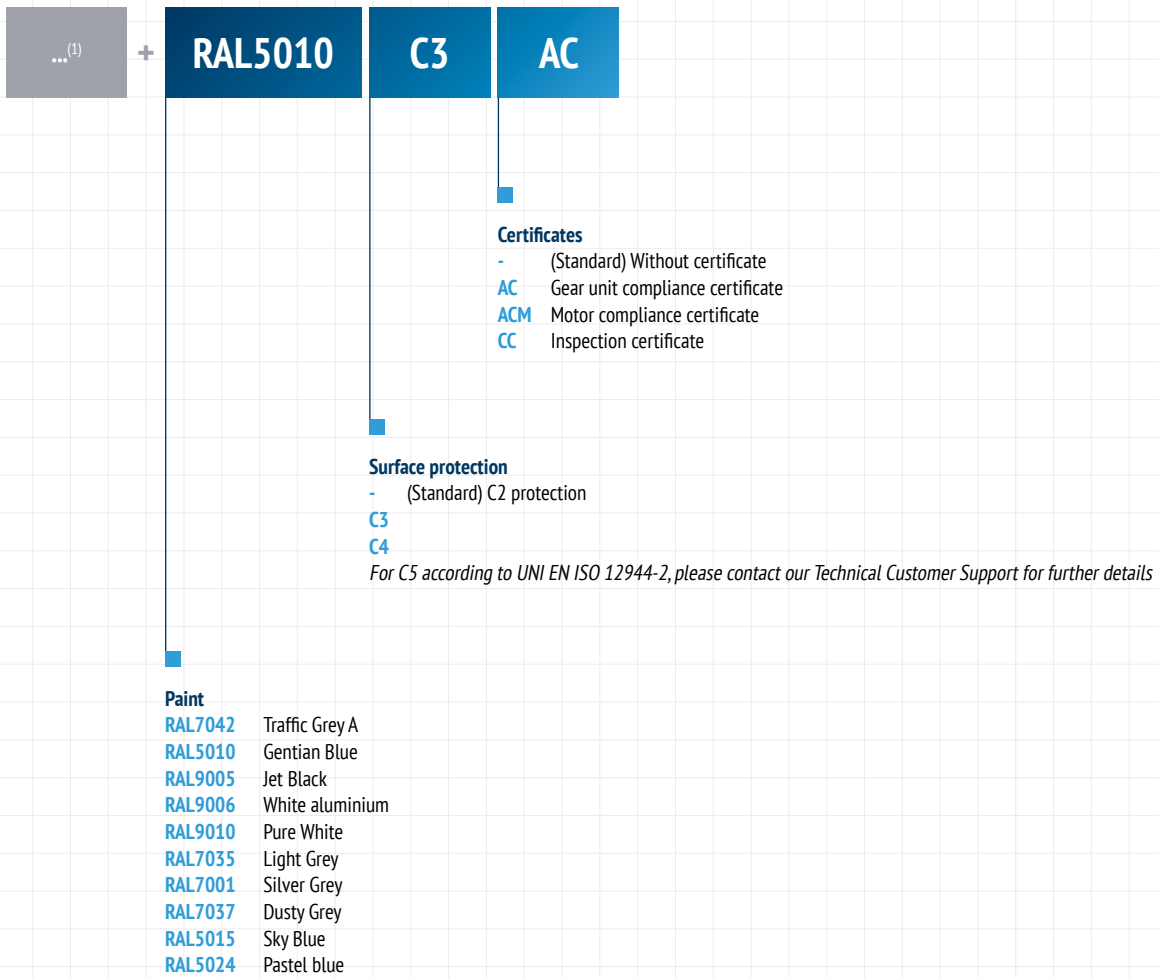

(1) Those options are available for Gear Units, Gearmotors, Gearbrakemotors, Stand alone and Stand alone Brakemotors

Options | EVOX Electric Motor Side

Option List

Capacitive filter

CF

Capacitive filter

An optional capacitive filter is available for brake motors type FD only. When the suitable capacitive filter is installed upstream of the rectifier (option CF), motors comply with the emission limits required by standard EN6100-6-3:2007 "Electromagnetic Compatibility – Generic Emission Standard – Part 6-3_ Residential, commercial and light industrial environment".

Essentially, the capacitive filter absorbs some of the electromagnetic waves interference so that the motor will be suitable for light industrial, residential and commercial applications.

Thermal protection

In addition to the standard protection provided by the magneto-thermal device, motors can be supplied with built-in thermal probes to protect the winding against overheating caused by severe and demanding application or by an insufficient ventilation of the environment.

This additional protection is highly recommended on servo-ventilated motors (IC416).

E3

Thermistors

These are semi-conductors having rapid resistance variation when they are close to the rated switch off temperature (150°C for CLF or 180° for CLH insulation class). Variations of the $R=f(T)$ characteristic are specified under DIN 44081, IEC 34-11 Standards. Positive temperature coefficient thermistors are normally used (also known as PTC "cold conductor resistors"). Usually this kind of thermal protection is easy to be found on inverters.

Thermistors cannot control relays directly and must be connected to a suitable disconnect device. Thus protected, three PTCs connected in series are installed in the winding, the terminals of which are located on the auxiliary terminal-board.

D3

Bimetallic thermostats

These types of protective devices house a bimetal disk. Bimetal switches operate on the principle of mechanical deformation as a result of long-term heating. Bimetal strips bent as a result of such heating have a spring action that results in sudden reversal of the curvature (concave to convex or vice-versa). When the rated switch off temperature (temperature (150°C for CLF or 180° for CLH insulation class) is reached, these temperature detectors (NC contacts) can deactivate an auxiliary circuit. The circuit can only be reclosed following a considerable fall in temperature. Three bimetallic thermostats connected in series are usually employed, with normally closed contacts. The terminals are located on an auxiliary terminal-board.

Bimetal switches are suitable protection devices in the case of slowly rising motor temperatures. When the motor current rises quickly (e.g. with a locked rotor), these switches are not suitable due to their large thermal time constants.

PT₁₀₀₀

Resistance thermometer

The resistance thermometer has a chip for a temperature sensor, the resistance of which changes in relation to temperature according to a series of reproducible basic values. The changes in resistance are transferred as changes in current.

At 0 °C, the measurement resistances are adjusted to 1000 Ω for the Pt1000 and correspond to the accuracy class B (i.e. the relationship between resistance and temperature). The limit deviation is ±0.3 °C, and the admissible deviations are defined in EN 60751. The Pt1000 resistance thermometer will, in the future, gradually replace the KTY84-130 temperature sensors available today. The relationship between the temperature and the electrical resistance of conductors is utilized in the Pt1000 to measure the temperature, just like with the additional resistance thermometers described above. Pure metals undergo larger changes in resistance than alloys and have a relatively constant temperature coefficient.

°C	Ω	°C	Ω
-40	843	110	1 423
-30	882	120	1 461
-20	922	130	1 498
-10	961	140	1 536
0	1 000	150	1 573
10	1 039	160	1 611
20	1 078	170	1 648
30	1 117	180	1 685
40	1 155	190	1 722
50	1 194	200	1 759
60	1 232	210	1 795
70	1 271	220	1 832
80	1 309	230	1 868
90	1 347	240	1 905
100	1 385	250	1 941

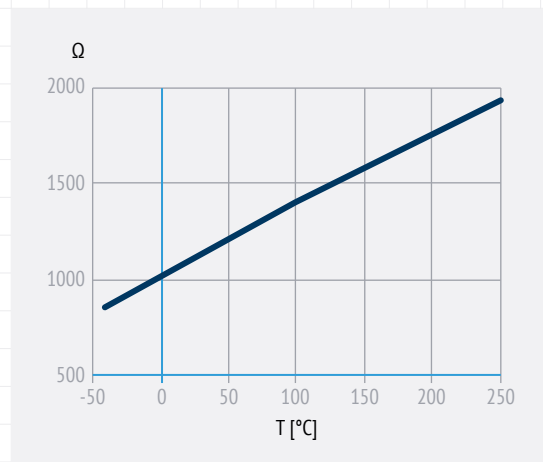

K1

KTY 84-130 temperature sensor

The design characteristics of this sub-group of PTC thermistors allow them to be used as positive temperature coefficient sensors with variable resistance. Functioning temperature range: 0°C ... +260°C. Within the measuring range, however, the KTY 84-130 characteristic rises almost linearly. The temperature sensor is embedded in the winding overhang of the motor in the same way as the components mentioned above. It is characterized by its outstanding precision, high reliability, and temperature stability, as well as a fast response time. Thanks to these properties, which permit the almost analog monitoring of winding temperature, the KTY 84-130 is preferred for converter operation. Thermistors cannot control relays directly and must be connected to a suitable disconnect device. Terminals (polarized) for 1 x KTY 84-130 are provided on an auxiliary terminal strip.

°C	Ω min	Ω max	°C	Ω min	Ω max
0	474	522	130	1 152	1 235
10	514	563	140	1 216	1 309
20	555	607	150	1 282	1 385
25	577	629	160	1 350	1 463
30	599	652	170	1 420	1 544
40	645	700	180	1 492	1 628
50	694	750	190	1 566	1 714
60	744	801	200	1 641	1 803
70	797	855	210	1 719	1 894
80	852	912	220	1 798	1 988
90	910	970	230	1 879	2 085
100	970	1 030	240	1 962	2 184
110	1 029	1 096	250	2 046	2 286
120	1 089	1 164	260	2 132	2 390

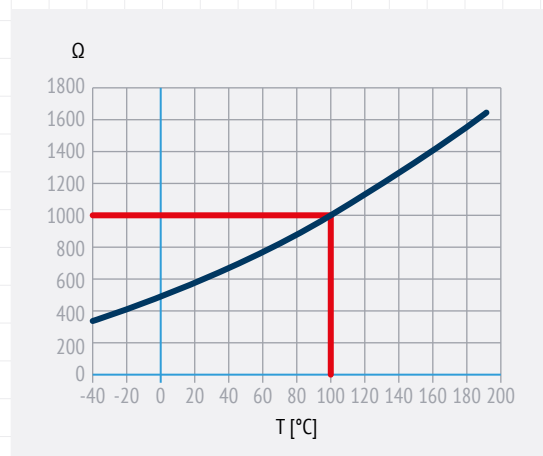

Options | EVOX Electric Motor Side

Option List

Feedback units

Motors can be combined with six different types of encoders in order to achieve feedback circuits. The installation requires an expansion module which depends on the type of the encoder selected.

Configurations with double-extended shaft (PS) and rain/fabric canopy (RC, TC) are not compatible with encoder installation.

EN1

Incremental encoder

These encoders are speed sensors obtained with optic-electronic technology and can be utilized as speed transducers. They are composed by an electric circuit and an optic disk integral with the shaft. Usually, there are 2 main standards for incremental encoder outputs: the Push-pull and the Line driver. The first one is useful in case of long wirings, the second one for applications in high electromagnetic pollution environments.

EN2

EN3

EN4

SIN/COS encoder

These encoders are both speed and position sensors obtained with optic-electronic technology and can be used as position and speed transducers at the same time. Usually employed for applications that require very high dynamic features.

EN5

Absolute encoder

These encoders are position sensors obtained with optic-electronic technology and can be utilized as position transducers. Usually employed for applications that require high precision

EN6

	EN1	EN2	EN3	EN4	EN5	EN6
Encoder type	Incremental	Incremental	Incremental	sin/cos	Absolute singleturn	Absolute multiturn
Output interface	TTL/RS 442	TTL/RS 442	HTL push-pull	Sinus 0.5 VPP	HIPERFACE®	HIPERFACE®
Power supply voltage VIN [V]	4 ... 6	10 ... 30	12 ... 30	4.4 ... 5.5	7 ... 12	7 ... 12
Output voltage [V]	5	5	12 ... 30	-	-	-
No-load operating current [mA]	120	100	100	40	80	80
Pulses per revolution	1024					
Steps per revolution	-	-	-	-	15 bit	15 bit
Revolutions	-	-	-	-	-	12 bit
Number of signals	6 (A, B, Z + inverted signals)			6 (cos-, cos+, sin-, sin+, Z, Z)		-
Max. output frequency [kHz]	600				200	
Max. speed [min ⁻¹]	6 000 (9 000 min ⁻¹ for 10s)					
Temperature range [°C]	-30 ... +100					
Protection class	IP65					

The Bonfiglioli ACU and ANG inverter series can manage all 6 types of encoders mentioned above and can be easily selected through the product configurator platform.

Anti – condensation heaters

H1

Anti – condensation heaters

Where an application involves high humidity or extreme temperature fluctuations, e.g. inactive motors in humid atmospheres or motors that are subject to widely fluctuating temperatures, motors may be equipped with an anti-condensate heater. A single-phase power supply is available in the auxiliary terminal board inside the main terminal box.

Values for the absorbed power are listed below:

	H1 1~230V ± 10% P[W]
BXN 63 ... BXN 80	10
BXN 90 BXN100 .. BXN 132	25

Warning! Always cut off the anti-condensation heater power before operating the motor.

Tropicalization

TP

Tropicalization

The TP option uses stators that are impregnated with highly hydrolysis-resistant resins. This allows the motors to be used in areas with increased air humidity and temperature, such as in tropical climate conditions.

The used wiring insulation materials and the impregnating resin protect the motor against termite-related damage

Second shaft extension

PS

Second shaft extension

The PS option provides the motor for an additional shaft end. This second shaft end is designed with a conventional keyway and key in accordance with DIN 6885 Sheet 1 (ISO 773).

This option is not compatible with variants RC, TC, EC, U1, EN1, EN2, EN3, EN4, EN5, EN6. For shaft dimensions please see motor dimensions tables.

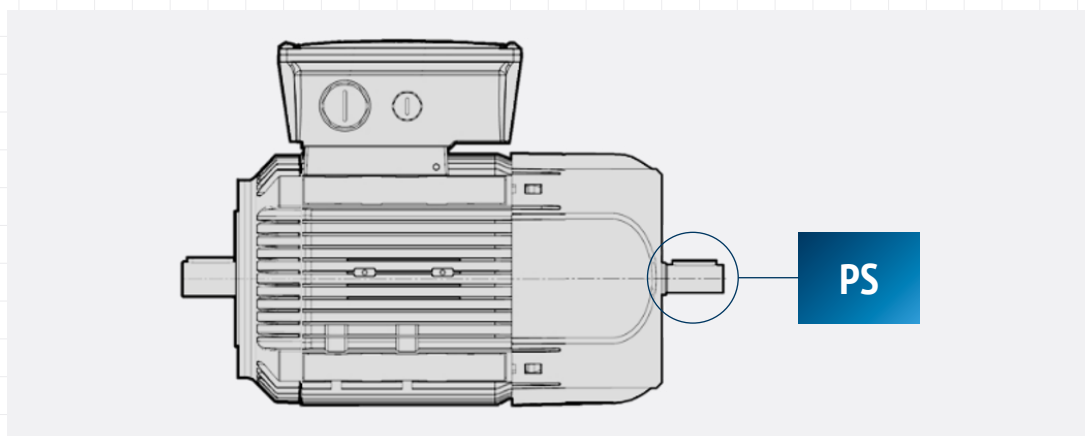

Options | EVOX Electric Motor Side

Option List

External protection

External protection canopies are used to prevent damages caused by external conditions, such as rain or cellulose particles to the electrical motor.

RC

Rain canopy

The rain canopy protects the motor from dripping and avoids the penetration of solid bodies. It is recommended when motor is installed in a vertical position with the shaft downwards. Only in this position a perfect coverage from rain is granted. The canopy extends the motor or brake motor length, please check the dimension table ([link](#)).

The drip cover is not compatible with variants PS, EN1, EN2, EN3, EN4, EN5, EN6.

TC

Textile canopy

Option TC is a cover variant for textile industry environments, where lint may obstruct the fan grid and prevent a regular flow of cooling air. The overall dimensions are the same as drip cover type RC.

This option with variants PS, EN1, EN2, EN3, EN4, EN5, EN6.

**EC**

Encoder canopy

Option EC is a cover variant specifically made for our encoders. It protects them from impacts and may help in prolonging their productive life.

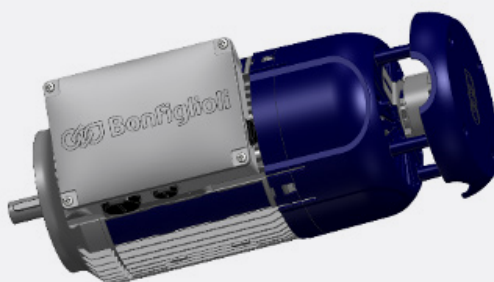

Certificates

ACM

Motor certificate of compliance

The document certifies the compliance of the product with the purchase order and the construction in conformity with the applicable procedures of Bonfiglioli's Quality System.

CC

Inspection certificate

The document entails checking the order compliance, visual inspection of external conditions and instrumental testing of the electrical characteristics in unloaded conditions. Inspected units are sampled within the shipping batch and marked individually.

Dimensions

EVOX Electric Motor

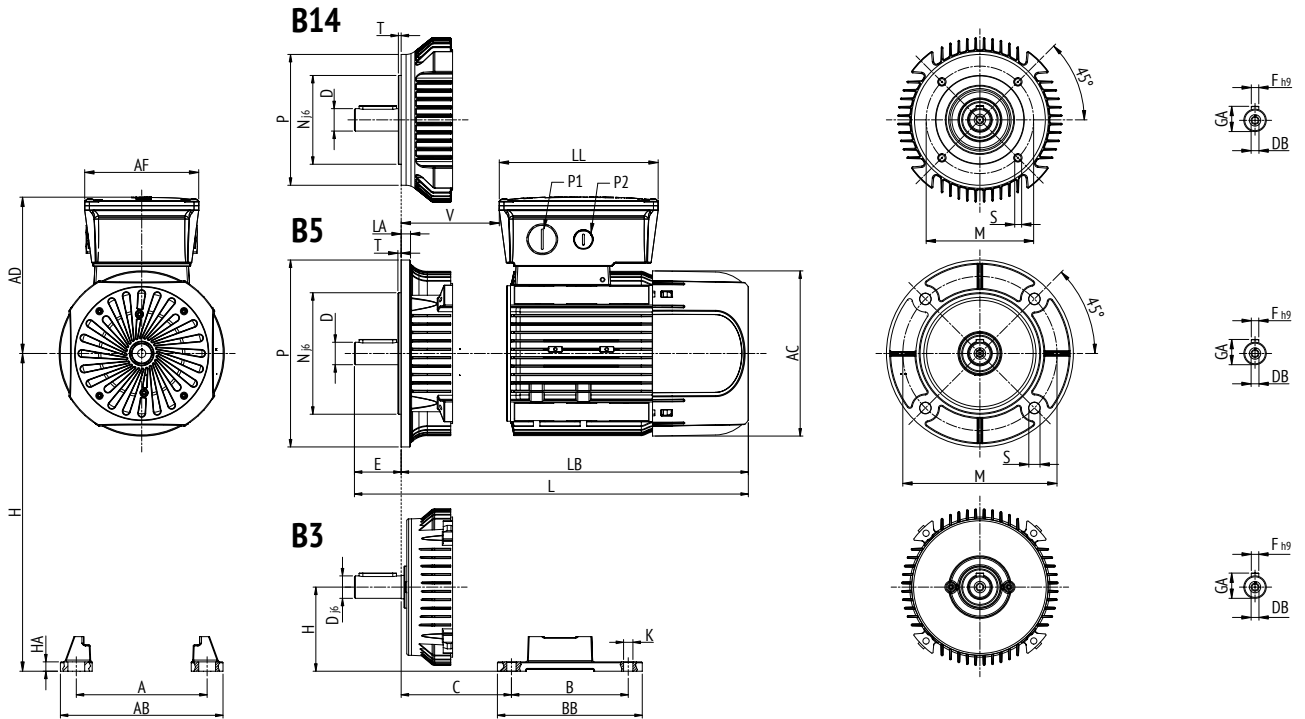

Motor Size	Output Shaft					Motor Overall Dimensions							Cable Entry	
	D	E	DB	GA	F	AC	L	LB	AD	AF	LL	V	P1	P2
	[mm]					[mm]								
BXN63	11	23	M4	12.5	4	122	291	258	136	112	165	37	M20	M16
BXN71	14	30	M5	16	5	138	292	262	138	112	165	34	M25	M16
BXN80	19	40	M6	21.5	6	158	346	306	148	112	165	40	M25	M16
BXN90	24	50	M8	27	8	177	365	315	170	122	170	43	M25	M16

Motor Size	B5 Version						B14 Version				
	M	N	P	S	T	LA	M	N	P	S	T
	[mm]						[mm]				
BXN63	115	95	140	9.5	3	9	75	60	90	M5	2.5
BXN71	130	110	160	9.5	3.5	9	85	70	105	M6	2.5
BXN80	165	130	200	11.5	3.5	10	100	80	120	M6	3
BXN90	165	130	200	11.5	3.5	10	115	95	140	M8	3

Motor Size	B3 Version							
	B	A	HA	BB	AB	K	C	H
	[mm]							
BXN63	80	100	8	96	120	7	40	63
BXN71	90	112	8	112	135	7	45	71
BXN80	100	125	8	124	153	10	50	80
BXN90S	100	140	8	155	174	10	56	90
BXN90L	125	140	8	155	174	10	56	90

Brake and E-motor options

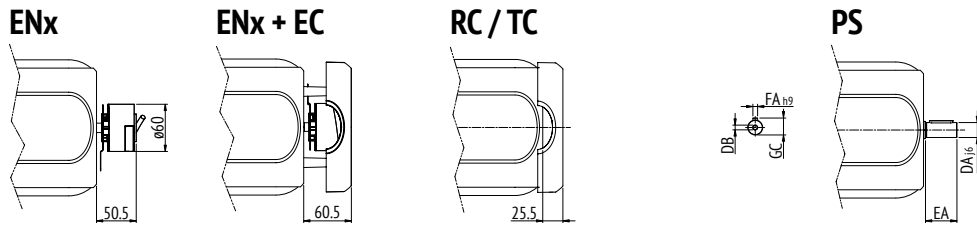
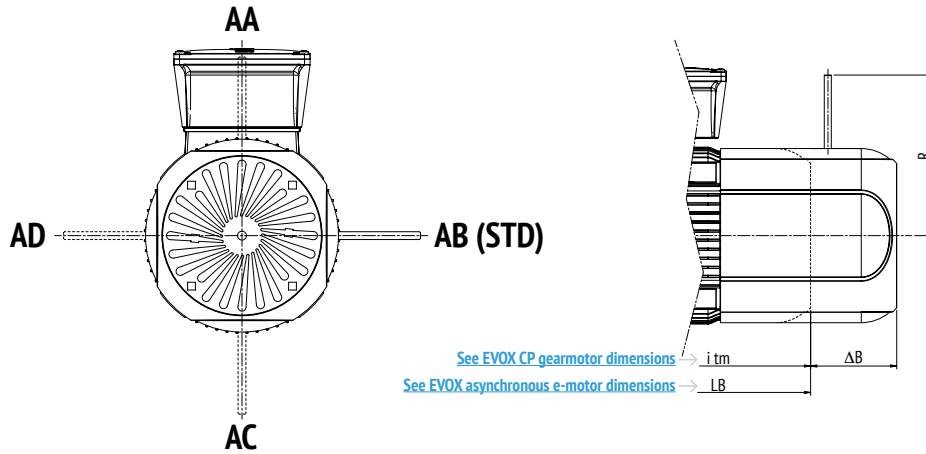

Motor Size	ΔB	R		PS Double Extended Motor Shaft				
		FD	FA	DA	EA	DB	GC	FA
	[mm]							
			[mm]					
BXN63	47	96	116	9	20	M3	10.2	3
BXN71	59	103	121	11	23	M4	12.5	4
BXN80	71	129	131	14	30	M5	16	5
BXN90	68	160	160	19	40	M6	21.5	6

Order info



Research & Development



Bonfiglioli's global research and development create breakthrough solutions that integrate the most advanced mechanical, electrical and hydraulic technologies. They meet the most demanding application requirements and support our customers' growth.

More than 200 employees around the world are involved in the group's research and development.



DESIGN YOUR SOLUTIONS



CO-ENGINEERING

We support our customers' projects from beginning to end.

At Bonfiglioli, we believe that product development relies on passion, efficient processes, and the ability to understand our customers' needs accurately.

First, our team identify the customer's needs after in-depth analysis drawn from our specific application expertise.

Through dedicated calculation tools, we can simulate the transmission's capabilities and performance allowing reducing development time.

The alignment phase allows us then to adapt our proposal according to key factors of performance, installation and maintenance.



The test centers at Bonfiglioli

Bonfiglioli's test laboratories support the various phases of the product life cycle, including development, certification and the production of solutions developed and manufactured in our plants around the world.

Our specialists are true partners to the R&D, technical and quality departments. They help validate each Bonfiglioli product from the smallest critical component to the overall solution.

The test centers regularly conduct additional tests to ensure the product durability and confirm the specifications declared during the official approval stage.

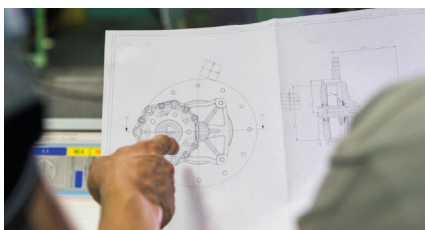

Global Presence



Bonfiglioli is a market force with a presence spanning 22 countries on 5 continents. Our organization makes the most of geographic proximity to offer complete solutions combining efficiency and competence.



3780
EMPLOYEES



20
BRANCHES



13
PLANTS



550
DISTRIBUTORS



80
COUNTRIES

We Are a Global Company

Thanks to an international network of sales branches and closely interconnecting production plants, we can guarantee the same high standards of Bonfiglioli quality anywhere at any given time. Aware that our direct presence in local markets is the key to long-lasting success, our family includes 20 sales branches, 13 production plants and more than 500 distributors around the world.

Our organization is always close by, offering complete and efficient solutions and supporting our customers with dedicated services, such as co-engineering or after-sales assistance.



Bonfiglioli Worldwide Locations

Australia

Bonfiglioli Transmission (Aust.) Pty Ltd.

2, Cox Place Glendenning NSW 2761
Locked Bag 1000 Plumpton NSW 2761
Tel. +61 2 8811 8000

Brazil

Bonfiglioli Redutores do Brasil Ltda.

Travessa Cláudio Armando 171 - Bloco 3 - CEP 09861-730
Bairro Assunção - São Bernardo do Campo - São Paulo
Tel. +55 11 4344 2322

China

Bonfiglioli Drives (Shanghai) Co. Ltd.

#68, Hui-Lian Road, QingPu District,
201707 Shanghai
Tel. +86 21 6700 2000

France

Bonfiglioli Transmission s.a.

14 Rue Eugène Pottier
Zone Industrielle de Moimont II - 95670 Marly la Ville
Tel. +33 1 34474510

Germany

Bonfiglioli Deutschland GmbH

Sperberweg 12 - 41468 Neuss
Tel. +49 0 2131 2988 0

Bonfiglioli Vectron GmbH

Europark Fichtenhain B6 - 47807 Krefeld
Tel. +49 0 2151 8396 0

O&K Antriebstechnik GmbH

Ruhrallee 8-12 - 45525 Hattingen
Tel. +49 0 2324 2050 1

India

Bonfiglioli Transmissions Pvt. Ltd.

Mobile, Wind

AC 7 - AC 11 Sidco Industrial Estate
Thirumudivakkam Chennai - 600 044
Tel. +91 844 844 8649

Industrial

Survey No. 528/1, Perambakkam High Road Mannur Village,
Sriperumbudur Taluk Chennai - 602 105
Tel. +91 844 844 8649

Industrial

Plot No.A-9/5, Phase IV MIDC Chakan,
Village Nighoje Pune - 410 501
Tel. +91 844 844 8649

Italy

Bonfiglioli S.p.A.

Headquarters

Via Bazzane, 33 - 40012 Calderara di Reno
Tel. +39 051 647 3111

EVO - Industrial

Via Bazzane, 33/A - 40012 Calderara di Reno
Tel. +39 051 6473111

Mobile, Wind

Via Enrico Mattei, 12 Z.I. Villa Selva - 47100 Forlì
Tel. +39 0543 789111

Bonfiglioli Riduttori S.p.A.

Via Bazzane, 33 - 40012 Calderara di Reno
Tel. +39 051 6473111

Bonfiglioli Mechatronic Research S.p.A

Via Unione 49 - 38068 Rovereto
Tel. +39 0464 443435/36

New Zealand

Bonfiglioli Transmission (Aust.) Pty Ltd.

88 Hastie Avenue, Mangere Bridge, 2022 Auckland
PO Box 11795, Ellerslie
Tel. +64 09 634 6441

Singapore

Bonfiglioli South East Asia Pte Ltd.

8 Boon Lay Way, #04-09,
8@ Tadehub 21, Singapore 609964
Tel. +65 6268 9869

Slovakia

Bonfiglioli Slovakia s.r.o.

Robotnícka 2129
Považská Bystrica, 01701 Slovakia
Tel. +421 42 430 75 64

South Africa

Bonfiglioli South Africa Pty Ltd.

55 Galaxy Avenue, Linbro Business Park, Sandton,
Johannesburg, 2090 South Africa
Tel. +27 11 608 2030

Spain

Tecnotrans Bonfiglioli, S.A.

Pol. Ind. Zona Franca, Sector C, Calle F, nº 6
08040 Barcelona
Tel. +34 93 447 84 00

Turkey

Bonfiglioli Turkey Jsc

Atatürk Organize Sanayi Bölgesi, 10007 Sk. No. 30
Atatürk Organize Sanayi Bölgesi, 35620 Çiğli - Izmir
Tel. +90 0 232 328 22 77

United Kingdom

Bonfiglioli UK Ltd.

Unit 1 Calver Quay, Calver Road, Winwick
Warrington, Cheshire - WA2 8UD
Tel. +44 1925 852667

USA

Bonfiglioli USA Inc.

3541 Hargrave Drive
Hebron, Kentucky 41048
Tel. +1 859 334 3333

Vietnam

Bonfiglioli Vietnam Ltd.

Lot C-9D-CN My Phuoc Industrial Park 3
Ben Cat - Binh Duong Province
Tel. +84 650 3577411



We have a relentless commitment to excellence, innovation and sustainability. Our team creates, distributes and services world-class power transmission and drive solutions to keep the world in motion.

HEADQUARTERS

Bonfiglioli S.p.A.
Via Bazzane, 33
40012 Calderara di Reno
Bologna (Italy)
www.bonfiglioli.com

