

CATALOGO GENERALE GENERAL CATALOGUE

CATENE MECCANICHE - CATENE SPECIALI
MECHANICAL CHAINS - SPECIAL CHAINS



To link for passion



To link for passion

A Maria Luisa nel vivo ricordo dei tuoi cari
In memory of our dearly beloved Maria Luisa



Cav. Giuseppe Vismara (1922 - 2008)



PROFILO AZIENDALE



COMPANY PROFILE

Manifattura Catene Viganò M.C.V. SpA nasce nel 1962 dall'intuizione e dalla tenacia del suo fondatore Cav. Giuseppe Vismara. 50 anni dopo la MCV è una azienda affermata, ed è punto di riferimento a livello mondiale nel settore delle catene industriali. La passione per il lavoro che il fondatore Cav. Vismara ha saputo trasmettere a tutti i collaboratori viene sottolineata nel motto "To Link for Passion", che MCV è orgogliosa di esibire vicino al tradizionale logo aziendale. La filosofia MCV, soddisfare le esigenze del cliente curando ogni dettaglio e proponendo soluzioni con un rapporto qualità prezzo estremamente conveniente, è stata perseguita negli anni portando MCV a raggiungere elevatissimi traguardi nella progettazione, costruzione e commercializzazione di catene industriali ed accessori. La gamma di produzione è molto vasta e comprende catene a maglie stampate, catene meccaniche per trasmissione e trasporto, catene per trazione e accessori. La produzione delle catene avviene completamente in Italia presso l'unità produttiva a Viganò, a cui si è aggiunta di recente la nuova unità produttiva di Missaglia. I processi produttivi sono certificati dal 1997 secondo la norma UNI EN ISO 9001, e particolare cura è prestata alla qualità sia del prodotto sia del servizio fornito.

Manifattura Catene Viganò M.C.V. Spa was founded in 1962 for the intuition and the tenacy of its founder Mr. Giuseppe Vismara. 50 years after MCV is a well established company and a world wide point of reference in the field of industrial chains. The passion for the work that the founder Mr Giuseppe Vismara has managed to convey to all his cooperators is emphasized by the motto "To Link for Passion", which MCV is proud to present near to the traditional corporate logo. MCV philosophy to meet customer requirements taking care of every detail and offering solutions at very good quality/price ratios has been pursued in years leading MCV to reach very high goals in design, construction and sale of industrial chains and accessories. The range of production is very wide comprising forged steel scraper chains, mechanical chains for transmission and conveying, traction chains and accessories. The chains are manufactured entirely in Italy at the production site in Viganò to which the new production unit in Missaglia has been recently added. The manufacturing processes are certified since 1997 according to the Norm UNI EN ISO 9001, giving special care to product and service quality.



Presenza globale

MCV è una azienda del cuore italiano ma oggi fortemente orientata all'estero. Negli ultimi anni la società si è strutturata commercialmente attraverso una rete di distributori e rivenditori che coprono a livello capillare Italia, Europa, Asia, Americhe, Australia e Africa.

Global presence

MCV is an "Italian heart company " today strongly oriented towards overseas. In recent years it received a renewed commercial structure supported by a network of distributors covering widespread Italy, Europe, Asia, America and Australia.



PROFILO AZIENDALE



COMPANY PROFILE

Sistema qualità e controllo qualità

I prodotti MCV sono conosciuti nel mondo per la elevata qualità e l'ottimo rapporto qualità/prezzo. Questi obiettivi sono stati raggiunti lavorando sulla efficienza produttiva e sul controllo qualità in tutte le fasi del processo. La certificazione UNI EN ISO 9001 attestata attualmente da TUV, da più di 10 anni supporta lo sviluppo della azienda e garantisce all'esterno la qualità del processo di progettazione e produzione.

Quality system and quality control

The MCV products are known worldwide for their top quality and their high quality/price ratio. These targets were reached working on the production efficiency and on the quality controls at all process stages. The UNI EN ISO 9001 certification assigned at present by TUV, supports has been supporting the company development in design and production quality since more than 10 years.





Ciclo produttivo catene meccaniche

Our production process mechanical chains



COMPANY PROFILE

TORNITURA A CONTROLLO NUMERICO
CNC TURNING



1
UFFICIO TECNICO
TECHNICAL DEPARTMENT

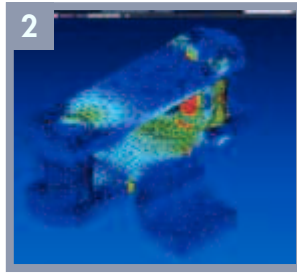

2
PROGETTAZIONE
ENGINEERING

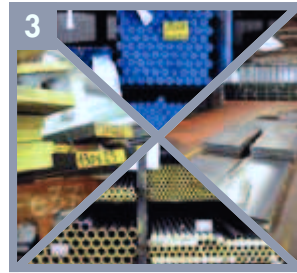

3
MAGAZZINO
WAREHOUSING

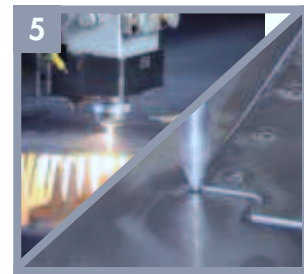

TAGLIO LASER/TAGLIO AD ACQUA
LASER/WATERJET CUTTING

PIEGATURA
BENDING

CENTRI DI LAVORO
MACHINING CENTERS

LAVORAZIONI SPECIALI
SPECIALITY MACHINING



TRATTAMENTO TERMICO
HEAT-TREATMENT

REPARTO TRANCIATURA
CUTTING PRESS

CONTROLLO
QUALITÀ
QUALITY
ASSURANCE

SALDATURA
WELDING

ASSEMBLAGGIO
ASSEMBLING

IMBALLAGGIO
PACKAGING





PROFILO AZIENDALE



COMPANY PROFILE



Ciclo produttivo catene a maglie stampate

Our production process drop forged chains

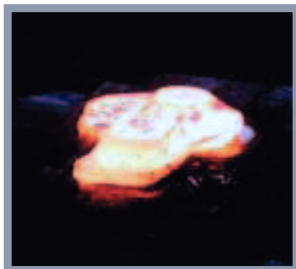

STAMPAGGIO A CALDO
DROP FORGING

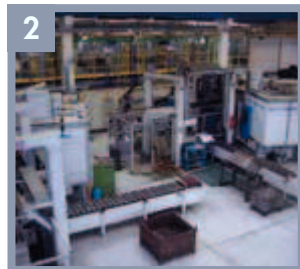

LAVORAZIONE MECCANICA
MACHINING



LAVORAZIONE MECCANICA
MACHINING



TRATTAMENTO TERMICO
HEAT TREATMENT

SALDATURA ROBOTIZZATA
ROBOT WELDING SYSTEM



MASCHERE DI SALDATURA
WELDING PREPARATION



PROVA DI TRAZIONE
TRACTION TEST

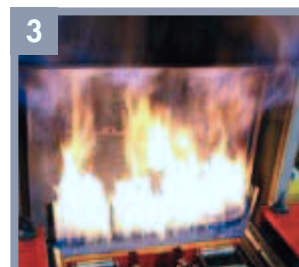
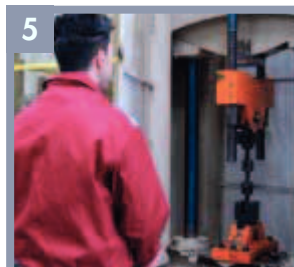

3

TRATTAMENTO TERMICO
HEAT TREATMENT



CONTROLLO SALDATURA
WELDING QUALITY



CONTROLLO QUALITÀ
QUALITY TESTING



ASSEMBLAGGIO
ASSEMBLING



IMBALLAGGIO
PACKING



Principali aree di applicazione

Industria del cemento e laterizi

Cemento e materiali sfusi
Trasporto clinker, gesso e sabbia
Elevatori a tazze
Trasportatori Apron
Trasportatori raschianti

Industria dell'acciaio

Banchi di trafilatura per tubi e profilati
Trasporto tubi
Trasporto coil e nastri
Trasporto fogli di lamiera
Trasporto billette
Trasporto sfridi di lavorazione meccanica
Trasporto rottame
Trasporto carbone, ferro e additivi

Industria mineraria

Grattatrici carbone, minerali a grana grossa e argilla
Frantoi

Industria del legno e della carta

Trasportatori raschianti
Trasporto tronchi
Linee segatrici
Trasporto tavole
Trasporto trucioli legno
Industria del mobile
Industria dei pannelli truciolari
Trasporto bobine di carta

Centrali elettriche

Trasporto carbone, biomasse, scorie e quarzo
Trasporto ceneri
Catene per trazione per movimentazione paratoie, dighe e chiuse
Trasportatori Apron
Industria dell'ambiente
Impianti trattamento rifiuti
Trasporto polveri (secco e umido)
Grattatrici negli impianti per biomasse
Trasporto sinterizzati
Impianti per trattamento acque e fanghi

Industria alimentare e molitoria

Trasporto materiali sfusi
Imbottigliamento e lavaggio bottiglie
Trasporto mais e soia
Olio e Biodiesel
Carico e scarico navi
Industria dello zucchero

Altre applicazioni

Industria automobilistica
Macchine posacatrame
Trasportatori per l'industria della produzione dell'asfalto
Scale mobili
Ascensori
Attrazioni parchi divertimento
Macchine scavafossi
Catene per macchine per il pane
Trasporto scatole e bottiglie

Industria chimica e fertilizzanti

Trasporto polveri e grani per la gomma
Filtri di precipitazione

Main areas of application

Cement and Concrete Industries

Cement and Concrete Industry
Clinker, Gypsum, Clay Reclaimers
Bucket Elevators
Apron Conveyors
Scraper Reclaimers

Steel Industry

Traction chains for Draw Benches
Piping conveyors
Strip coil conveyors
Steel sheet and structural steel conveyors
Billet conveyors
Steel chips for the metalworking industry
Scrap conveyors
Coal, iron ore and additive, conveyors

Mineral Industry

Coal, coarse-grained ore, limestone, slate reclaimer
Stone crusher

Wood and Paper Industry

Scraper Reclaimers
Log conveyors
Sawing lines
Plank transports
Woodchip handling
Furniture Industry
Laminated wood Industry
Paper Coil conveyors

Power Stations

Coal, biomass, slag, quartz conveyors
Hot Bottom Ash Conveyors
Traction chains for Hydro Electric Power Plants
Apron Conveyors
Environmental Industry
Waste treatment plants
Powder Transport (dry and wet)
Reclaimer in biomass plants
Sinter conveyors
Water and sludge treatment plants

Food Industry

Bulk material conveyors
Bottle transport and washing
Mais and Soy conveyors
Oil & Biofuel
Port and ship handling
Sugar industry

Other Applications

Automotive
Tar-layer Machines
Drag conveyor chains for the Asphalt Industry
Escalators
Elevators
Theme Parks
Trench Digging Machines
Bakery chains
Box and bottle conveyors

Chemical and Fertilizer Industry

Polymers and Granules for the rubber & dust
Precipitators from filter holders





Composizione di una catena meccanica

Una catena è un organo meccanico che, nella sua forma più semplice, è caratterizzato da cinque elementi: rulli, bussole, che insieme alle piastre interne, formano la maglia interna; mentre i perni, insieme alle piastre esterne, formano la maglia esterna. L'articolazione e quindi la possibilità di ingranare su di una ruota dentata, è resa possibile dal gioco esistente tra bussola e perno, il primo dei quali presenta un diametro interno leggermente superiore rispetto al secondo.

Le principali dimensioni di una trasmissione a catena sono: il passo (P), il diametro dei rulli (Dr) o il diametro bussola (Db) e la larghezza interna (Li). Il passo è la misura che identifica la distanza nominale tra i due perni consecutivi di una catena; il diametro rullo o il diametro bussola indicano i rispettivi diametri esterni; mentre la larghezza interna è la distanza tra le due facce delle piastre interne. Una catena è una successione di maglie interne ed esterne che articolano tra di loro dando luogo ad un organo flessibile per una trasmissione di moto.

Maglia interna

È formata da due piastre. Ciascuna piastra presenta due fori dove vengono forzate le bussole. Sulle bussole vengono montati i rulli che hanno lo scopo di ridurre l'attrito durante l'ingranamento con la ruota dentata. Nelle catene a bussole, mancano i rulli.

Maglia esterna

È formata da due piastre. I perni, passanti all'interno dei fori delle bussole, e forzati all'interno dei fori delle piastre esterne, sono l'elemento di collegamento alle maglie interne. Possono esistere svariate tipologie di perni: non smontabili o smontabili.

Maglia giunto

È una maglia esterna smontabile e viene utilizzata per congiungere uno o più spezzoni di catena.

Maglia falsa

È una maglia speciale, smontabile, che permette di ottenere spezzoni di catena con passi dispari. È formata da: un rullo, una bussola, un perno e due piastre piegate. La maglia falsa funziona quindi per metà come maglia interna e per metà come maglia esterna.

Materiali e trattamenti termici

Riportiamo di seguito alcune indicazioni sul tipo di acciaio generalmente utilizzato per le catene meccaniche.

La scelta del tipo di acciaio deve essere fatta sulla base delle condizioni di esercizio della catena o su indicazione del costruttore dell'impianto di cui la catena è parte.

Piastre

- Acciaio al carbonio non trattato o trattato
- Acciaio legato non trattato o trattato
- Acciaio Inox

Perni

- Acciaio al carbonio trattato
- Acciaio legato trattato
- Acciaio Inox

Bussole

- Acciaio al carbonio trattato
- Acciaio legato trattato
- Acciaio Inox

Rulli

- Acciaio al carbonio trattato
- Acciaio legato trattato
- Acciaio Inox

Attacchi

- Acciaio Dolce



To link for passion

Catene Meccaniche
CATENE SPECIALI

How is a chain made up

Chains are mechanical components in their simplest conception composed by five elements: roller, bushings, assembled with inner sideplates are forming the inner link; while pins together with sideplates form the outer link. The chain articulation that is the ability to engage on a toothed wheel is made possible by the gap between the bushing and the pin, the bushing presenting a slightly bigger diameter respect to the pin.

The main dimensions of a chain transmission are: the pitch (P), the roller diameter (D_r) or the bush diameter (D_b), and the inner width (L_i). The pitch dimension is the nominal distance between two consecutive pins of the chain; the roller and the bush diameter correspond to the respective outer diameters; the inner width is the distance between the inner sides of the inner sideplates. Chains are made by sequences of inner and outer links articulating together and become a flexible part of the drive transmission.

Inner link

It is composed by two sideplates. Each sideplate has two bores into which bushings are forced. Rollers are mounted on the bushings and reduce the friction while they engage the toothed wheel. In the chains named "bush chains" the rollers are not present.

Outer link

It is composed by two sideplates. The pins pass through the bores of the bushings, they are forced into the outer sideplates and by that the linking element of the inner links. They can be supplied in two different types: undetachable and detachable.

Connecting link

It is a demontable outer link and it is used to connect one or more chain lengths together.

Off-set link

It is a special demontable link which permits to obtain chain lengths with an odd number of pitches. It is composed by: one roller, one bushing, one pin and two bent sideplates. The off-set sideplate works half as inner link and half as outer link.

Materials and heat treatments:

We give you as follows some indications on the type of steels generally used for mechanical chains. The choice must depend on the working conditions of the chain or on the information given by the plant manufacturer of which the chain is constituent element.

Sideplates

- Carbon steel treated or untreated
- Alloy steel treated or untreated
- Stainless steel

Pins

- Carbon steel treated or untreated
- Alloy steel treated or untreated
- Stainless steel

Bushings

- Carbon steel treated
- Alloy steel treated
- Stainless steel

Rollers

- Carbon steel treated
- Alloy steel treated
- Stainless steel

Attachments

- Mild steel

Mechanical Chains
SPECIAL CHAINS



Composizione di una catena / Chain composition

Mechanical Chains
SPECIAL CHAINS

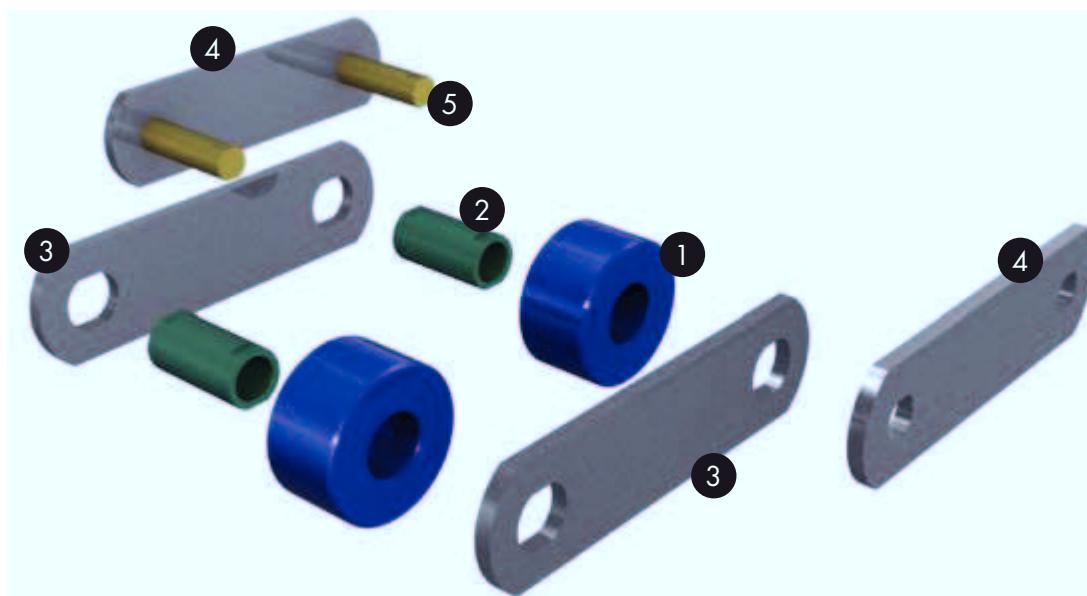

1 Rulli

I rulli ruotano generalmente sulle bussole e svolgono due funzioni: ridurre il coefficiente d'attrito sui trasportatori; ridurre al minimo l'attrito sui pignoni quando la catena entra ed esce dai denti di un pignone. I rulli possono essere temprati oppure cementati.

2 Bussole

Le bussole costituiscono la struttura portante per la rotazione del perno nell'articolazione sopra ad un pignone. Inoltre servono come superficie portante per i rulli della catena, oppure per il contatto sui pignoni quando la catena è senza rulli. Generalmente sono cementate.

3 4 Piastre (interne e esterne)

Le piastre sono elementi di trazione della catena e determinano il passo della stessa. Possono essere disassate, dritte o di qualsiasi altra forma. Per una maggiore resistenza e durata, le piastre, possono essere trattate a caldo.

5 Perni

I perni collegano le maglie della catena. Sono fermati nelle piastre per mezzo di un accoppiamento (d'interferenza) in modo tale che la rotazione avviene tra il perno e la bussola. I perni possono essere forniti trattati a caldo e non, oppure cementati e temprati; dipende solitamente dal tipo di applicazione.

1 Rollers

The rollers generally rotate in the bushing and have two functions: to reduce the coefficient of friction on conveyors; to minimize the friction on sprockets as the chain engages and disengages the teeth of the same. Rollers can be either hardened or case hardened.

2 Bushing

The bushings constitute the bearing structure in the rotation of the pin articulating over a sprocket. They serve also as a bearing surface for the rollers of the chain or, if the chain has no rollers, for the contact with the sprocket. They are generally case hardened.

3 4 Plates (inner and outer)

The plates are the traction members of the chain and determine its pitch. They can be off-set, straight or of any other shape. In order to guarantee a major resistance and longer service life, the plates can be heat treated.

5 Pins

The pins connect the chain links. They are locked in the plates by a coupling (of interference) so that the rotation takes place between the pin and the bushing. The pins can be supplied either with or without heat treatment or case hardened, usually depending on the type of application.



To link for passion

Catene Meccaniche
CATENE SPECIALI**Materiali e trattamenti termici / Materials and heat treatment**Mechanical Chains
SPECIAL CHAINS

L'articolazione della catena ed il continuo attrito tra il diametro esterno del perno ed il diametro interno della bussola provocano fenomeni di usura con conseguente aumento dei giochi e riduzione nella vita utile della catena stessa.

Per limitare l'usura nell'articolazione tra perno e bussola è necessario eseguire dei trattamenti termici di indurimento superficiale su queste parti, e questi trattamenti devono essere eseguiti secondo i più alti standard qualitativi.

MCV dispone di una linea di trattamento termico di ultima generazione, che consente di eseguire, controllare e certificare tutti i trattamenti termici sulle parti delle catene e degli accessori.

Nella tabella di seguito riportiamo i materiali standard impiegati ed i relativi trattamenti termici.

The articulating of the chain with continuous friction between the pin outer diameter and the inner bush diameter, causes wearing, with consequent increase of the clearances and reduction of the running life of the chain itself.

To prevent this articulation wearing the most, it becomes necessary to carry out heat treatments of hardening on the surface of these parts, treatments to be performed according to the highest quality standards.

MCV is equipped with a heat treatment line of high technologic level, able to execute, check and certify all the heat treatments on the parts of the chains and accessories.

Kindly please refer to the following table with our standard materials and correspondent heat treatments.

COMPONENTI CATENA CON MATERIALI E TRATTAMENTI TERMICI CHAIN PARTS WITH MATERIALS AND HEAT TREATMENTS			
PIASTRE / PLATES	PERNI / PINS	BUSSOLE / BUSHES	RULLI / ROLLERS
AC	AC/BON	AC/CT	AC/CT
AC/BON	AL/CT	AC/BON+TI	AC/BON
AL/BON	AL/BON+TI	AL/CT	AC/BON+TI
SS3	AC/BON+TI	AL/BON+TI	AL/CT
	SS3	SS3	AL/BON
	SS4/BON	SS4/BON	AL/BON+TI
	SS4/BON+TI		SS3
			SS4/BON
			SS4/BON+TI

MATERIALI - MATERIALS

AC - Acciaio al carbonio - Carbon Steel

AL - Acciaio legato - Alloyed Steel

SS3 - Acciaio INOX Serie 300 - Stainless Steel Series 300

SS4 - Acciaio INOX Serie 400 - Stainless Steel Series 400

TRATTAMENTI TERMICI - HEAT TREATMENTS**ACCIAIO AL CARBONIO - CARBON STEEL**

Bonifica - Hardening and Tempering

(BON)

Bonifica + Tempra ad Induzione - Harden. and tempering + Induction Hardening

(BON+TI)

Cementazione + Tempra - Case Hardening

(CT)

ACCIAIO LEGATO - ALLOYED STEEL

Bonifica - Hardening and Tempering

(BON)

Bonifica + Tempra ad Induzione - Harden. and tempering + Induction Hardening

(BON+TI)

Cementazione + Tempra - Case Hardening

(CT)



Catene a blocchi
Block chains

Mechanical Chains
SPECIAL CHAINS

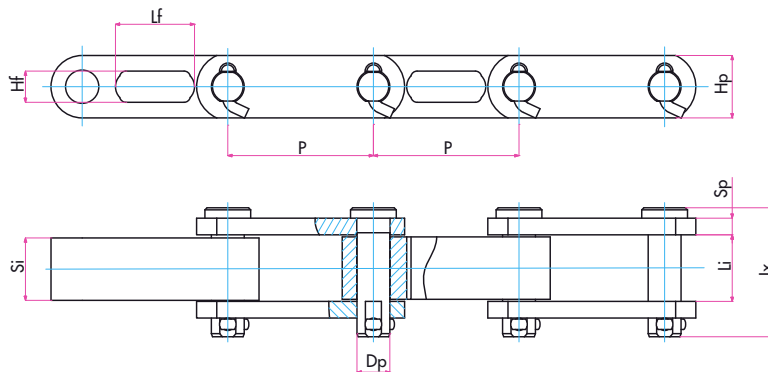

STILE M - STYLE M

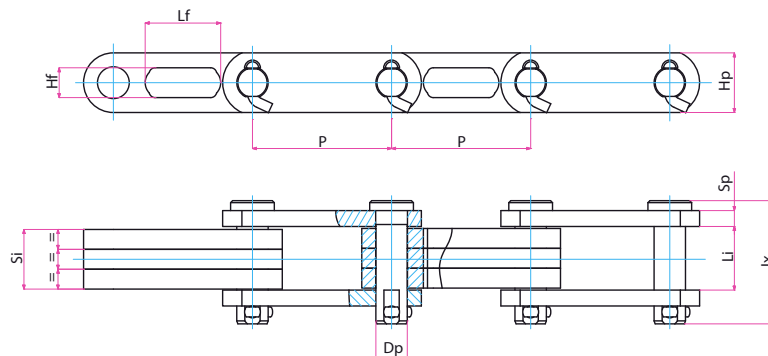

STILE C - STYLE C

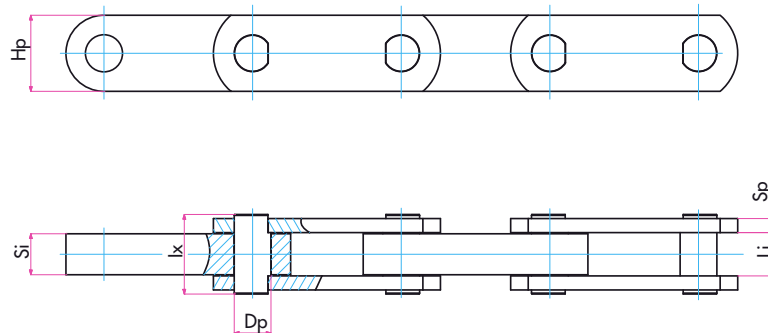

STILE V - STYLE V

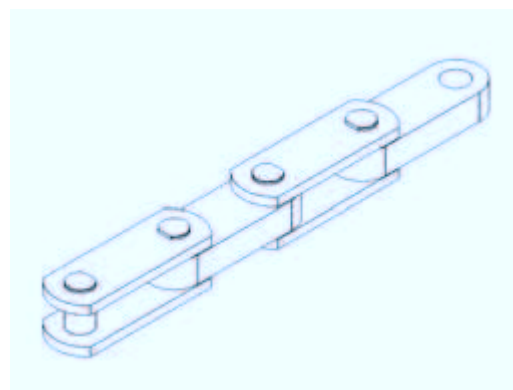
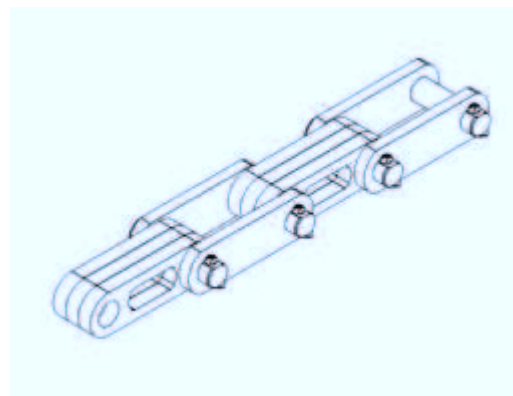
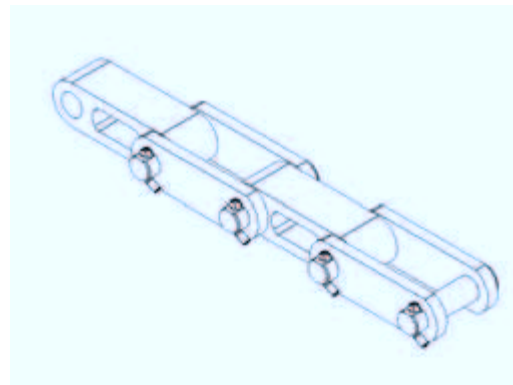

Codice/Code	Stile Style	Dimensioni / Dimensions									Carico medio di rottura Average breaking load kN	Peso al metro Weight per meter kg/m
		P	Dp	Li	Hp	Si	Se	Hf	Lf	lx		
		mm	mm	mm	mm	mm	mm	mm	mm	mm		
636	M	70,0	15,8	30	30	29	8	15	38	62	130	3,5
637	C	80,0	17,8	31	40	30	10	22	38	70	250	4,75
638	V	127,0	22,0	22	40	20	10	—	—	48	285	6,50
639	V	127,0	28,5	27	50	25	12	—	—	56	410	16,30
640	V	127,0	31,4	38	65	35	12	—	—	68	640	28,5
641	V	152,4	31,4	38	65	35	12	—	—	68	640	24,0
642	V	254,0	31,4	38	65	35	12	—	—	68	640	31,0



Catene a blocchi con attacchi
Block chains with attachments



Mechanical Chains
SPECIAL CHAINS

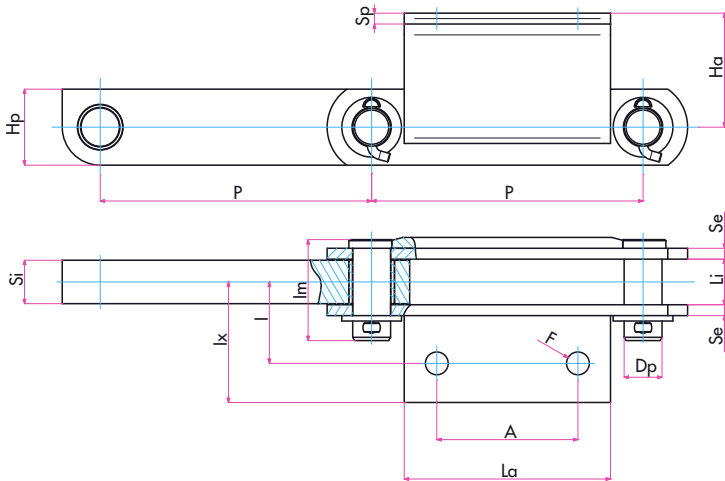

STILE V - STYLE V

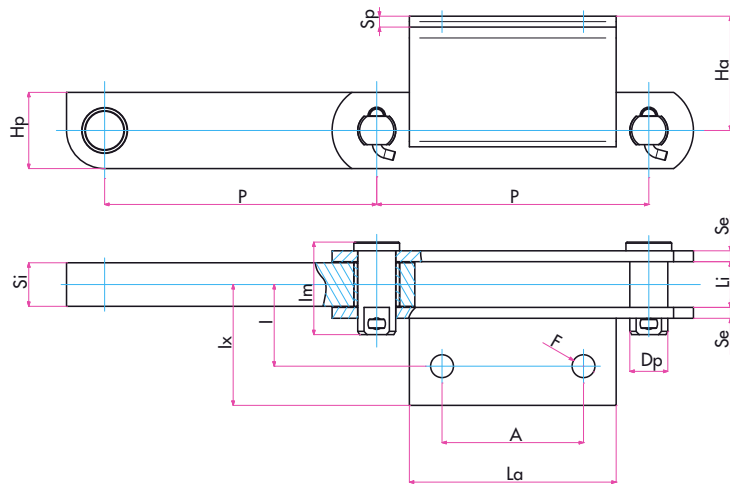

STILE M - STYLE M

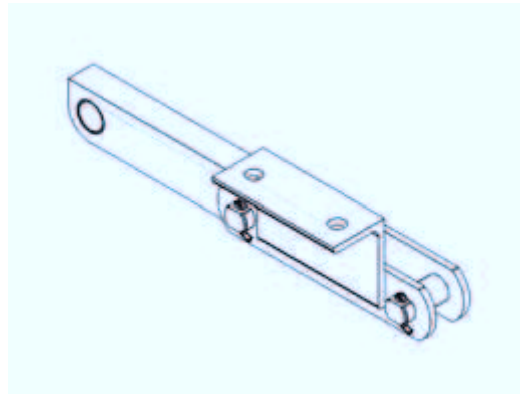

Codice/Code	Stile Style	Dimensioni / Dimensions														Carico medio di rottura / Average breaking load kN
		P	Li	Dp	Hp	Si	Se	Im	La	A	F	Sp	Ix	Ha	I	
		mm	mm	mm	mm	mm	mm	mm	mm	mm	mm	mm	mm	mm	mm	
643/250	M	250	42	36	70	40	18	106	145	70	25	15	150	55	100	700
644/200	M	200	22	25	50	20	8	60	110	55	18	10	100	70	53	280
645/250	V	250	42	35	70	40	20	115	150	70	26	15	165	90	120	800
646/250	V	250	32	30	60	30	15	90	140	70	26	15	140	85	98	550



Catene trasporto casse
Case conveyor chains

Mechanical Chains
SPECIAL CHAINS

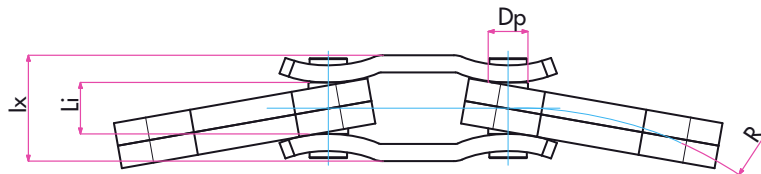
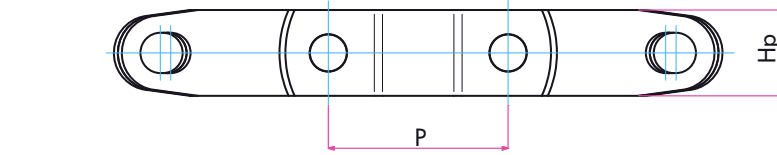

STILE V - STYLE V

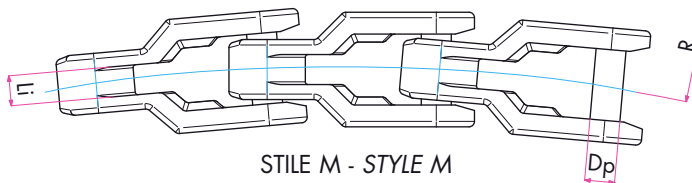
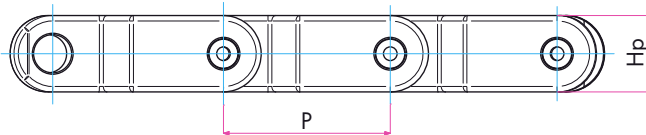

STILE M - STYLE M

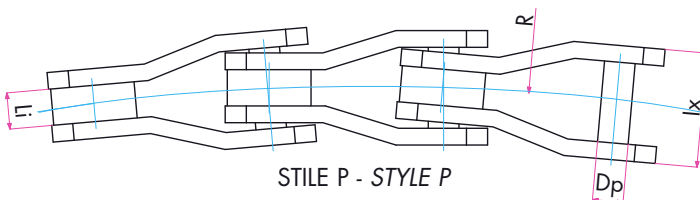
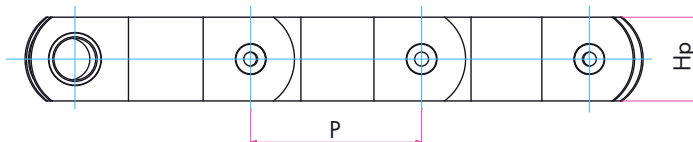

STILE P - STYLE P

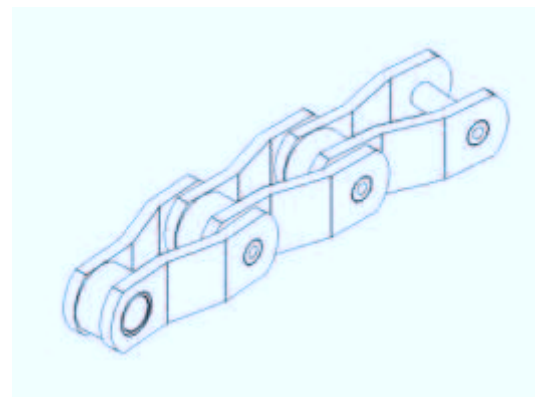
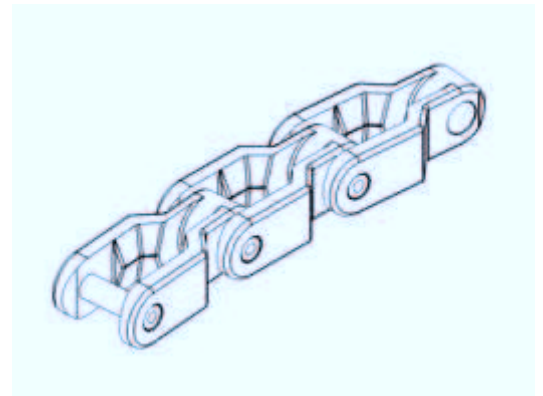
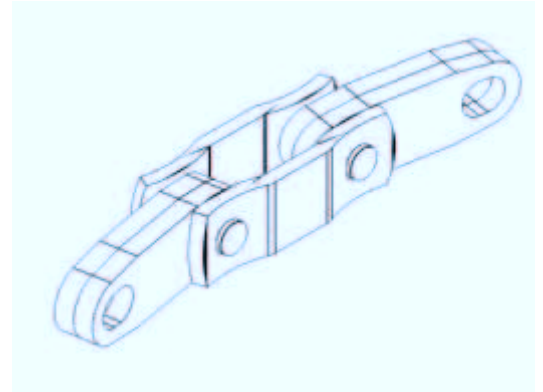

Codice/Code	Stile Style	Dimensioni / Dimensions						Carico medio di rottura Average breaking load
		P	Li	Dp	Hp	lx	R*	
		mm	mm	mm	mm	mm	mm	kN
635/635	M	63,50	13	11	29	43	485	46
635/635 A	P	63,50	13	11	30	41	400	70
635/6285	V	62,85	18	14	30	38	600	175
635/762 A	V	76,20	18	14	30	38	600	175
635/1016	V	101,60	19	14	30	39	600	175

*R = raggio minimo di curvatura
minimum bending radius



To link for passion

Catene Meccaniche
CATENE SPECIALI

Catene per elevatori portatazze
Chains for bucket elevators



Mechanical Chains
SPECIAL CHAINS

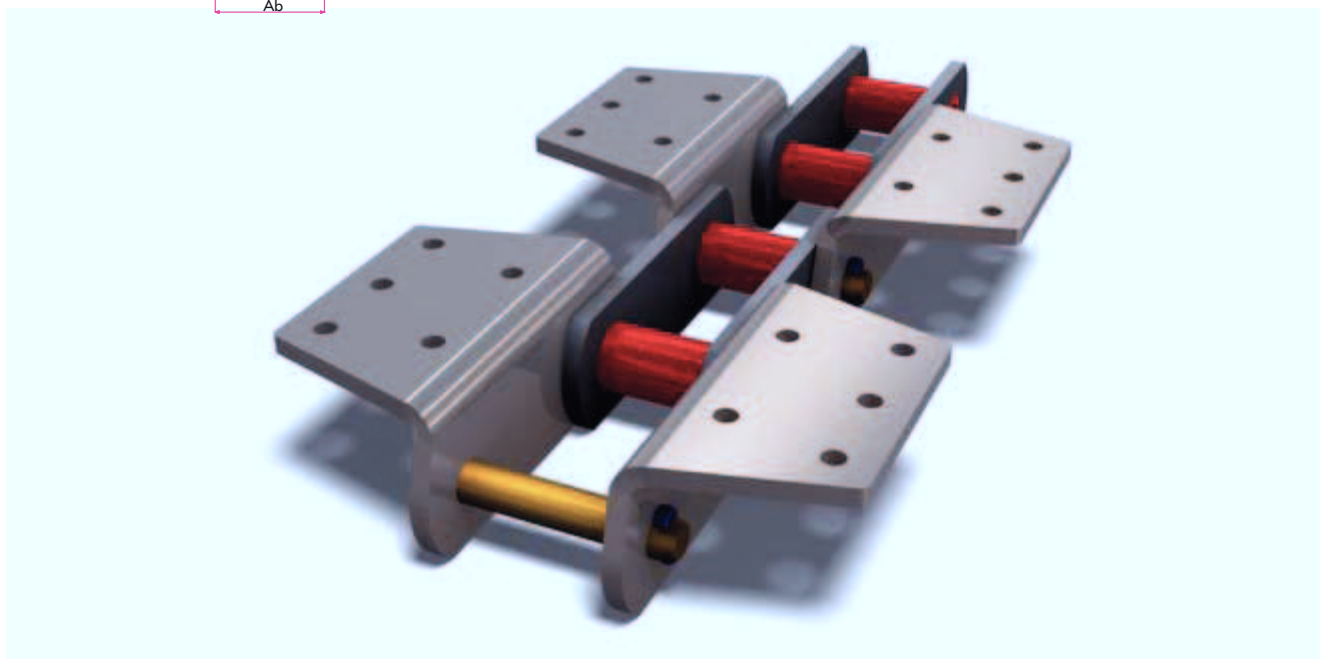
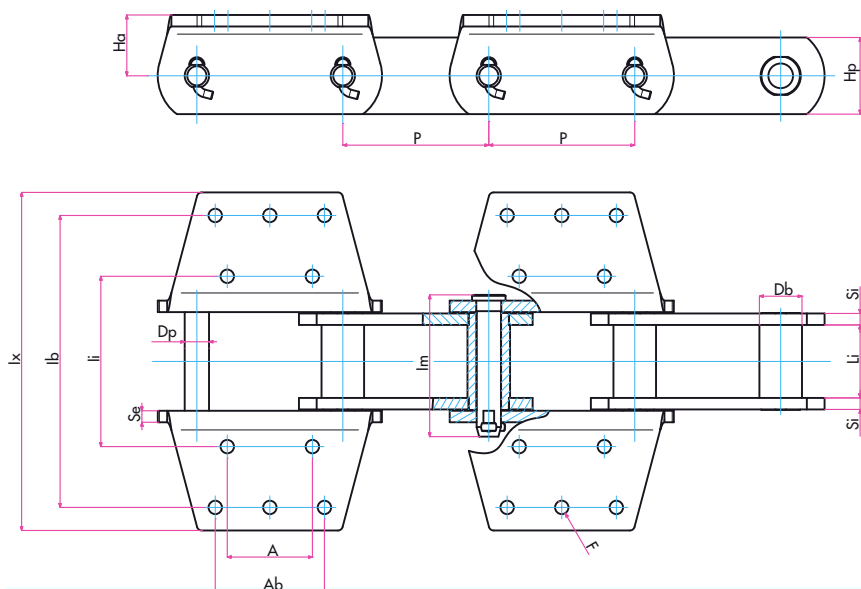

Codice/Code	Dimensioni / Dimensions															Carico medio di rottura Average breaking load kN
	P	Li	Db	Dp	Hp	Si	Se	F	Im	A	Ab	li	lb	Ha	lx	
	mm	mm	mm	mm	mm	mm	mm	mm	mm	mm	mm	mm	mm	mm	mm	
4856	152,4	76,2	44,45	25,40	65	12	12	18	148	63,5	—	184,0	—	47,6	240	470
4857	152,4	76,2	44,45	25,40	80	12	12	14	148	88,9	88,9	177,8	304,8	63,5	360	750
4859	152,4	94,0	60,00	31,75	100	15	15	18	182	70,0	114,3	228,6	330,2	76,2	382	900
4861	160,0	119,0	62,00	36,00	110	15	15	18	205	100,0	150,0	250,0	310,0	70,0	380	1.100
4864	177,8	94,0	60,00	31,75	100	15	15	18	182	95,2	139,7	228,6	330,2	76,2	382	900

N.B.: A richiesta gli attacchi possono essere forniti con 3 o 4 fori.
NOTE: On request the attachments can be supplied with 3 or 4 holes.

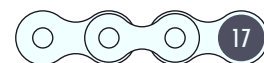



Catene per elevatori portatazze
Chains for bucket elevators

Mechanical Chains
SPECIAL CHAINS

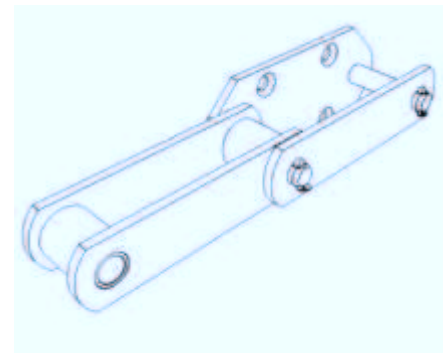
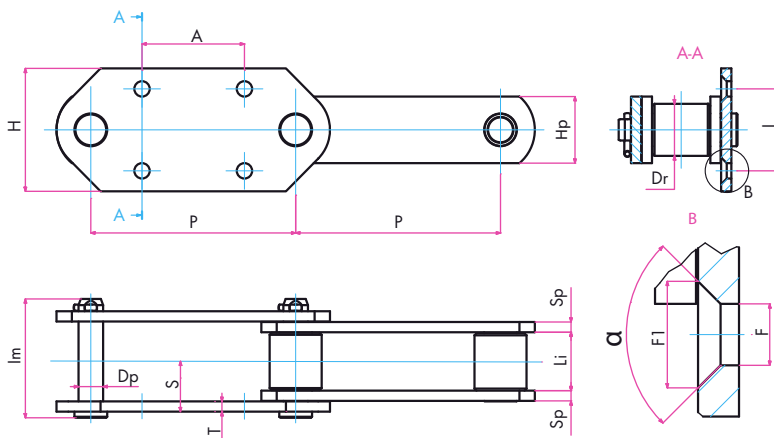

STILE G4-1 / STYLE G4-1

Codice/Code	Dimensioni / Dimensions							Carico medio di rottura serie standard Average breaking load standard series kN	Carico medio di rottura serie rinforzata Average breaking load reinforced series kN
	P	Li	Dp	Dr	Hp	Sp	lm		
	mm	mm	mm	mm	mm	mm	mm		
S10150	150,0	30	14,50	29,00	40	6,00	68	125	230
S12152	152,4	37	15,90	35,00	45	8,00	83	200	290
S12200	200,0	37	15,90	35,00	45	8,00	83	200	290
S17200	200,0	51	19,00	40,00	50	10,00	109	260	400
S26200	200,0	57	24,00	50,80	65	10,00	116	350	580
S17250	250,0	51	19,00	40,00	50	10,00	109	260	400
S26250	250,0	57	24,00	50,80	65	10,00	116	350	580
S36250	250,0	67	28,00	57,20	80	12,00	145	550	950
S26300	300,0	57	24,00	50,80	65	10,00	129	350	580
S36300	300,0	67	28,00	57,20	80	12,00	158	550	950
S60300	300,0	77	35,00	70,00	90	12,50	168	-	1.100
S36350	350,0	67	28,00	57,20	80	12,00	158	-	950
S60350	350,0	77	35,00	70,00	90	12,50	168	-	1.100
S90350	350,0	88	42,00	85,00	110	15,00	194	-	1.750
S60400	400,0	77	35,00	70,00	90	12,70	171	-	1.100
S90400	400,0	88	42,00	85,00	110	15,00	197	-	1.750
S120400	400,0	100	50,00	100,00	130	20,00	225	-	2.600

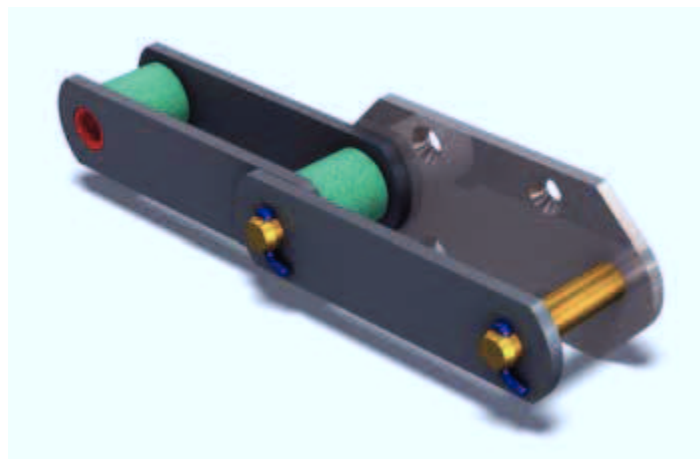



To link for passion

Catene Meccaniche
CATENE SPECIALI

Catene per elevatori portatazze
Chains for bucket elevators



Mechanical Chains
SPECIAL CHAINS

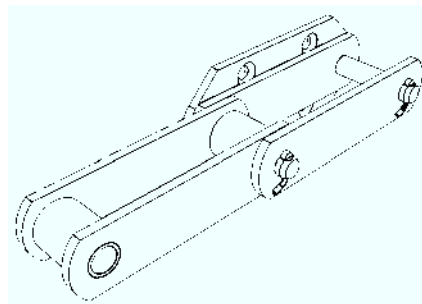
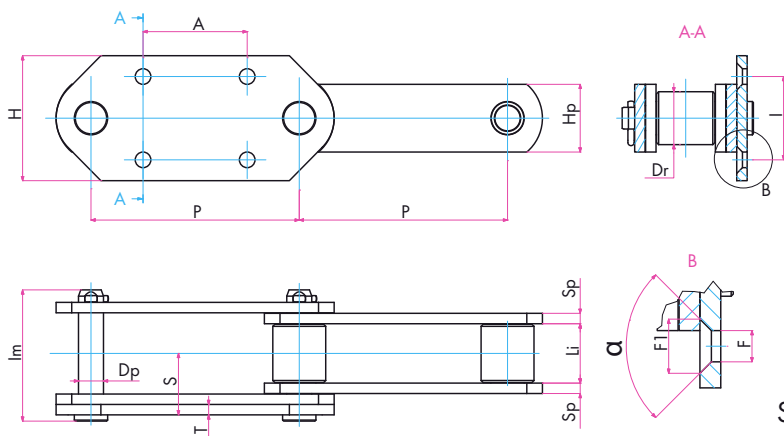

STILE G4-2 / STYLE G4-2

Codice/Code	Stile attacco Attachement style	Dimensioni / Dimensions							
		S	A	I	H	T	F	α	F1
		mm	mm	mm	mm	mm	mm	mm	mm
S 10150	G4 - 1	28,0	75	70	110	6	15	90	25
S 12152	G4 - 1	35,5	100	80	120	8	15	90	26
S 12200	G4 - 1	35,5	100	80	120	8	15	90	26
S 17200	G4 - 1	45,5	100	80	120	10	15	90	26
S 26200	G4 - 1	49,0	100	80	120	10	15	90	26
S 17250	G4 - 1	46,0	140	100	150	10	19	90	32
S 26250	G4 - 1	49,0	140	100	150	10	19	90	32
S 36250	G4 - 1	60,0	140	100	150	12	19	90	32
S 26300	G4 - 2	60,0	170	140	200	12	24	90	38
S 36300	G4 - 2	72,0	170	140	200	12	24	90	38
S 60300	G4 - 2	77,0	170	140	200	12	24	90	38
S 36350	G4 - 2	72,0	200	170	240	12	28	60	40
S 60350	G4 - 2	77,0	200	170	240	12	28	60	40
S 90350	G4 - 2	89,5	200	170	240	12	28	60	40
S 60400	G4 - 2	81,0	230	200	280	15	35	60	50
S 90400	G4 - 2	92,0	230	200	280	15	35	60	50
S 120400	G4 - 2	106,0	230	200	280	15	35	60	50

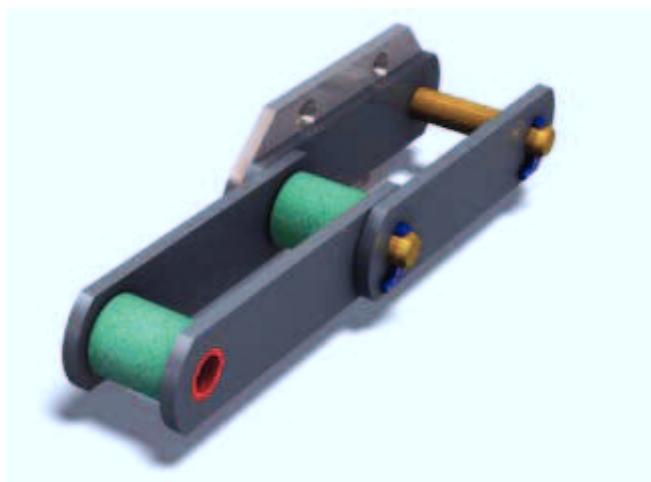



Catene per elevatori portatazze
Chains for bucket elevators

Mechanical Chains
SPECIAL CHAINS

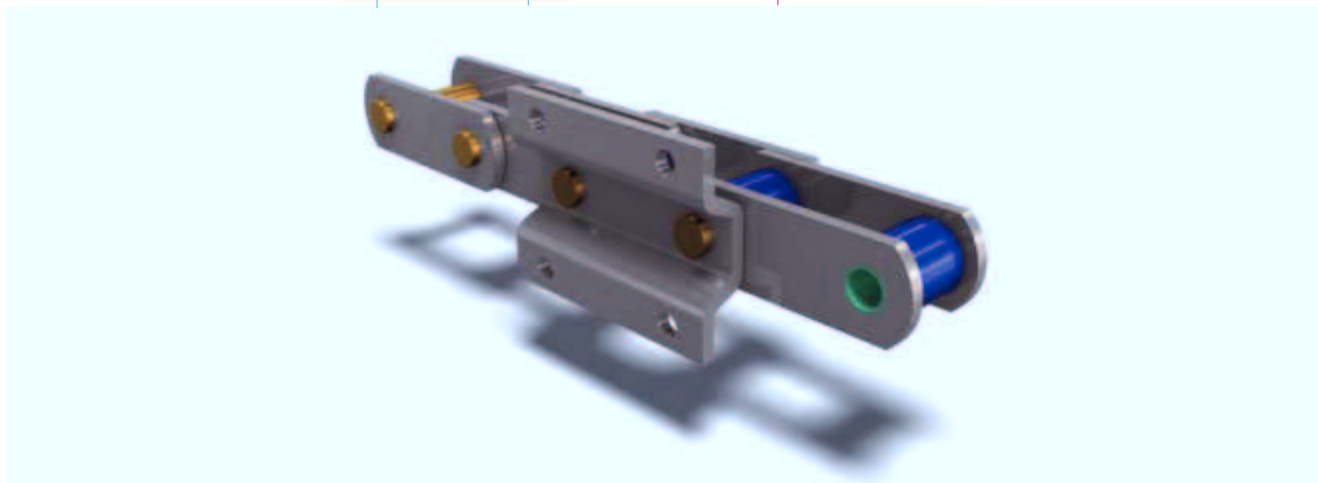
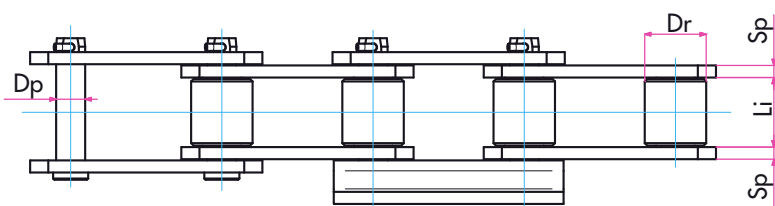
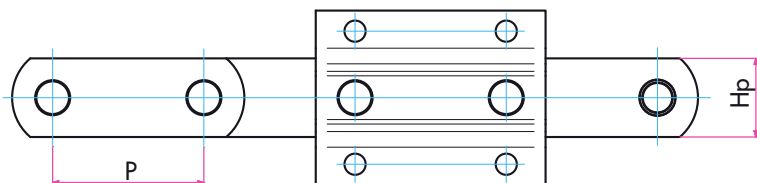

Codice/Code	Dimensioni / Dimensions						Carico minimo di rottura Minimum breaking load kN	Peso al metro Weight per meter kg/m
	P	Li	Dp	Dr	Hp	S		
CPE H300-B10-A	75	30	14,5	29	40	6	225	11
CPE H300-B12-A	76,2	37,1	15,9	34,9	45	8	280	17
CPE H450-B12-A	100	37,1	15,9	34,9	45	8	280	16
CPE H450-B17-A	100	51,4	19,10	40,1	50	10	385	23
CPE H450-B26-A	100	57,2	24	50,8	65	10	563	30
CPE H600-B17-A	125	51,4	19,1	40,10	50	10	385	20
CPE H600-B26-A	125	57,2	24	50,8	65	10	563	26
CPE H600-B36-A	125	66,7	28	57,2	80	12	870	43
CPE H800-B26-A	150	57,2	24	50,8	65	10	563	23
CPE H800-B36-A	150	66,7	28	57,2	80	12	870	42
CPE H800-B60-A	150	77	35	70	90	12	1040	55
CPE H011-B36-A	175	66,7	28	57,2	80	12	870	41
CPE H011-B60-A	175	77	35	70	90	12	1040	52
CPE H011-B90-A	175	88	42	85	110	15	1630	81



Catene per industria saccarifera serie DIN 654
Chains for sugar industry DIN 654 series



Mechanical Chains
SPECIAL CHAINS

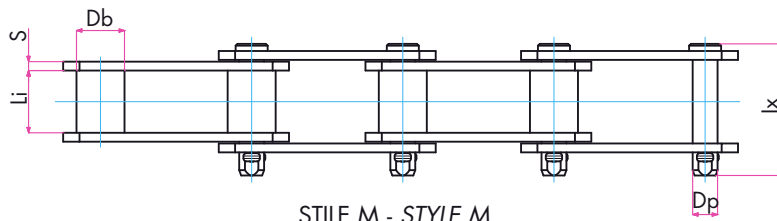
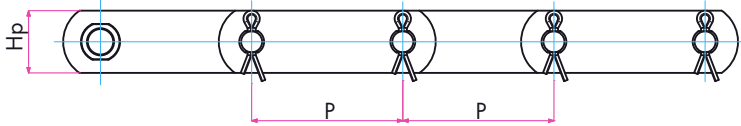

STILE M - STYLE M

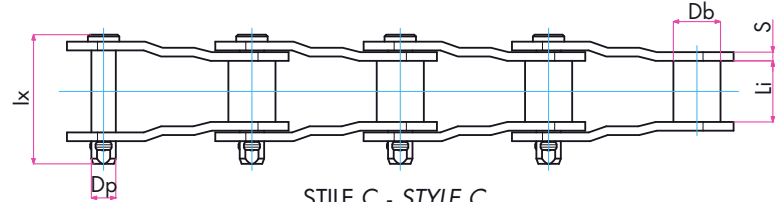
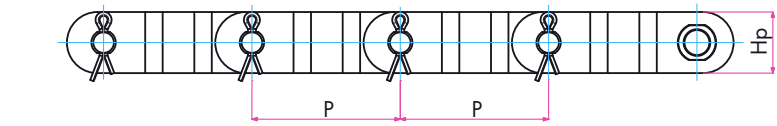
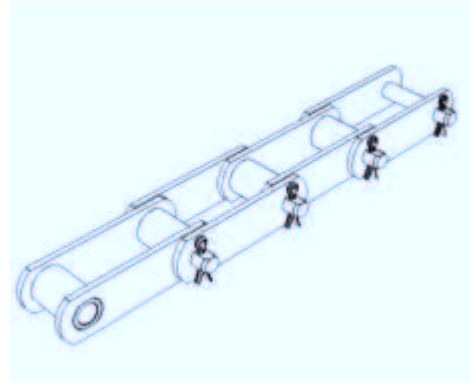

STILE C - STYLE C

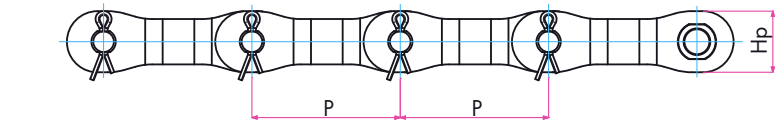
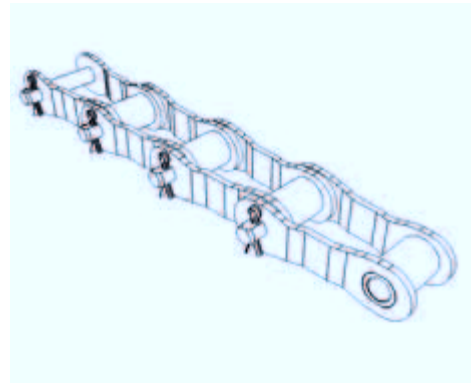

STILE V - STYLE V

Dimensioni / Dimensions

Codice/Code	Stile Style	Dimensioni / Dimensions							Carico medio di rottura Average breaking load kN
		P	Li	Db	Dp	Hp	S	lx	
		mm	mm	mm	mm	mm	mm	mm	
415 / Z	M	41,5	20,0	17	8	25	4	48	40
420 / Z	M	42,0	25,0	19	10	25	4	55	40
595 / Z	M	59,5	28,0	21	10	30	5	62	56
630 / Z	M	63,0	29,5	21	10	30	5	64	56
650 / Z	M	65,0	33,0	25	12	30	5	70	56
850 / Z	M - C	85,0	35,0	27	14	35	5	74	80
100 / Z	V	100,0	31,0	23	12	32	5	69	80
100 / ZA	M - C	100,0	29,0	27	13	35	6	71	100
100 / ZB	M - C	100,0	41,0	30	15	40	7	85	130
135 / Z	M - C	135,0	33,0	27	15	35	8	82	130



> **Attacchi per catene industria saccarifera**
Attachments for sugar industry chains

Mechanical Chains
SPECIAL CHAINS

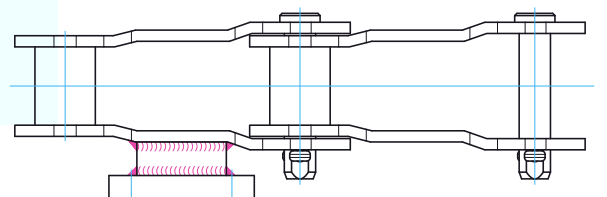
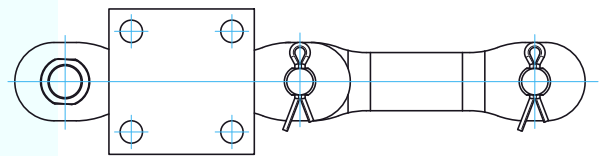
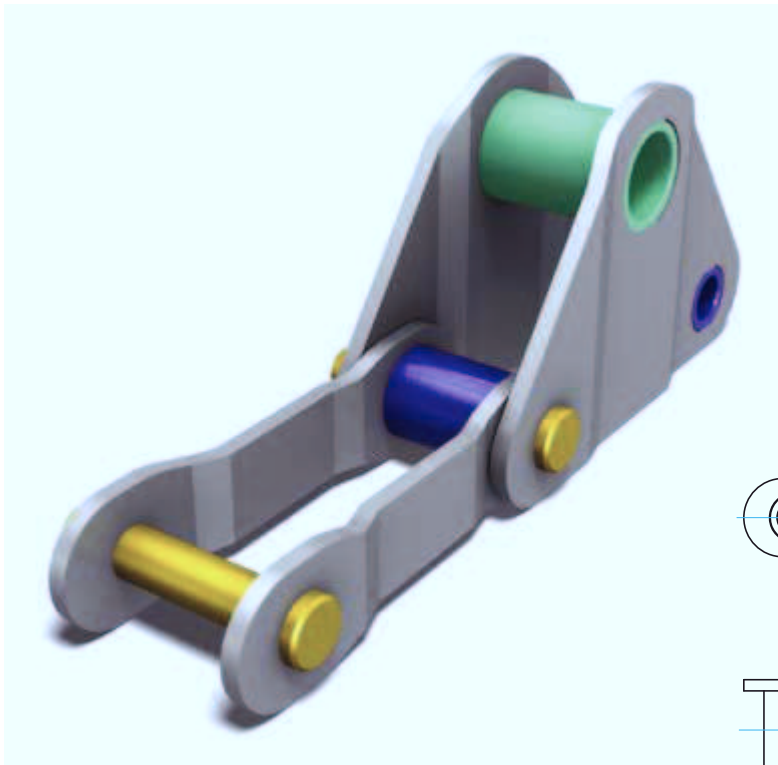
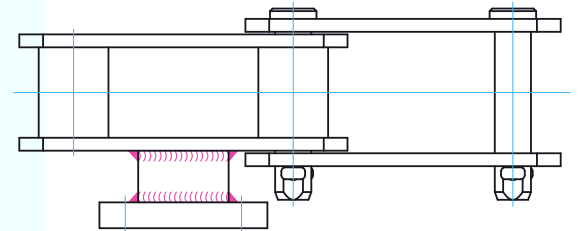
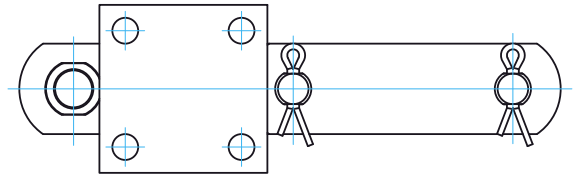
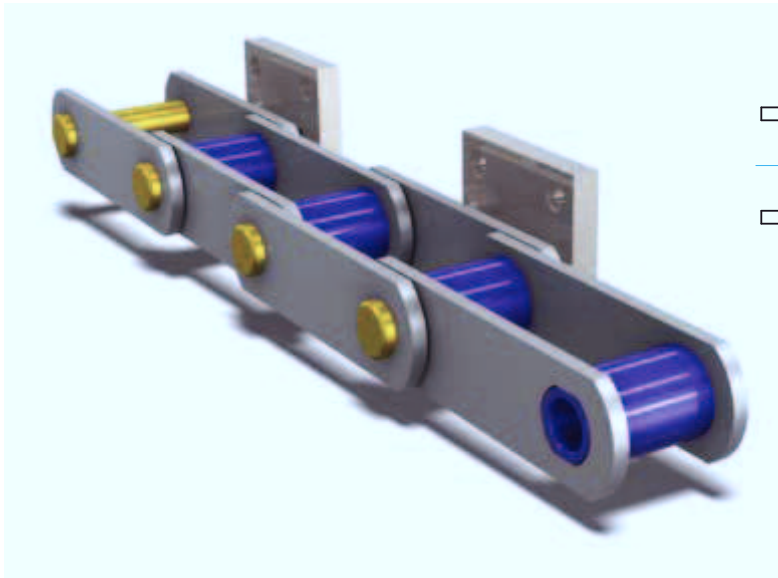



Catene per industria zaccarifera
Chains for sugar industry



Mechanical Chains
SPECIAL CHAINS

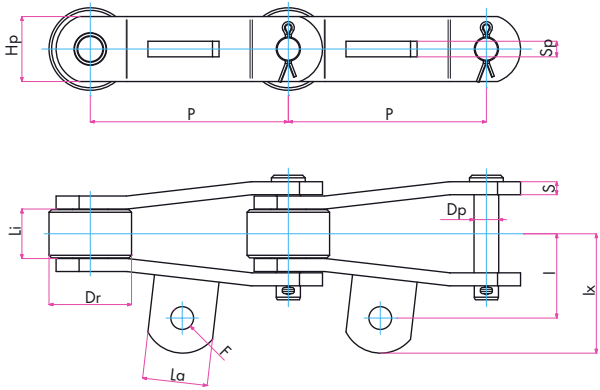

STILE M CON ATTACCO A42
M STYLE WITH A42 ATTACHMENT

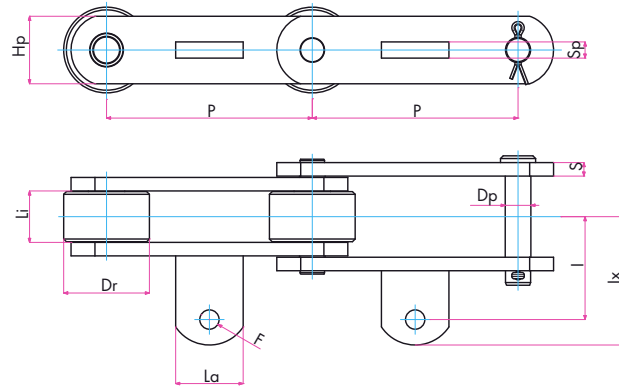

STILE V CON ATTACCO A42
V STYLE WITH A42 ATTACHMENT

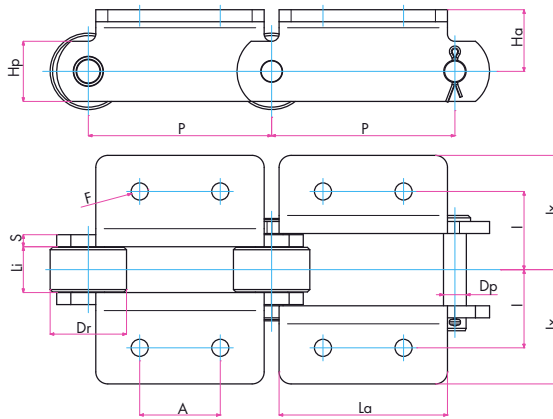

STILE V CON ATTACCO B2
V STYLE WITH B2 ATTACHMENT

Codice/Code	Stile Style	Dimensioni / Dimensions													Tipo di attacco Attachment style	Carico medio di rottura Average breaking load
		P	Li	Dr	Dp	Hp	S	Sp	F	La	I	Ix	Ha	A		
		mm	mm	mm	mm	mm	mm	mm	mm	mm	mm	mm	mm	mm		
21300	M	152,4	38,1	63,5	19,0	50	10	12	17,5	50	65,0	92	—	—	A42	310
960	V	152,4	38,1	69,8	19,0	50	10	—	14,3	140	56,0	75	41,3	76,2	B2	310
21840	M	152,4	38,1	76,2	22,0	50	10	12	17,5	50	67,0	91	—	—	A42	300
11311	V	152,4	38,1	76,2	19,0	50	10	—	14,3	140	76,2	95	41,3	67,0	B2	310
17960	V	152,4	38,1	69,8	22,0	60	10	—	14,3	110	56,0	73	41,3	76,2	B2	400
9600	V	152,4	38,1	69,8	22,0	60	12	—	14,3	110	56,0	76	41,3	76,2	B2	460
8000	V	203,2	46,0	88,9	25,4	80	12	—	14,3	178	66,0	91	56,0	114,3	B2	65



> **Catene per posa catrame**
Chains for asphalt machinery

Mechanical Chains
SPECIAL CHAINS

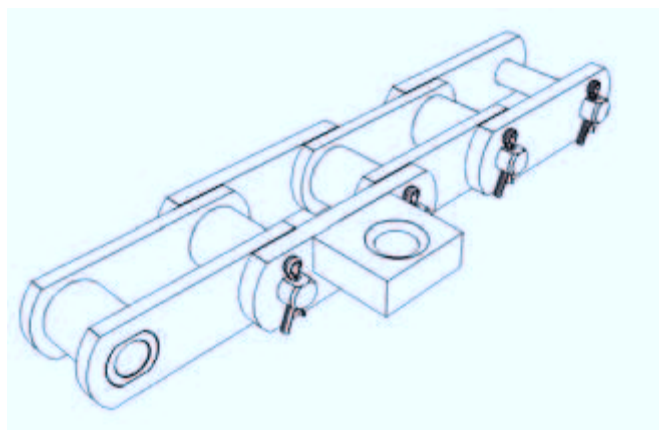
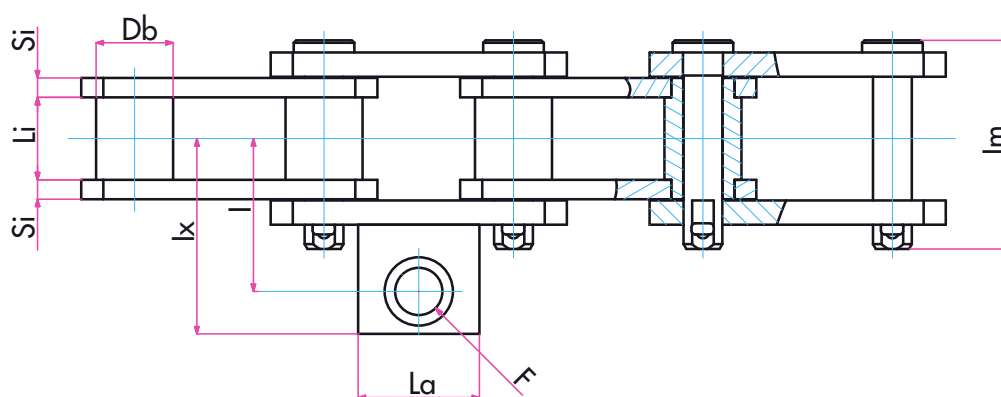
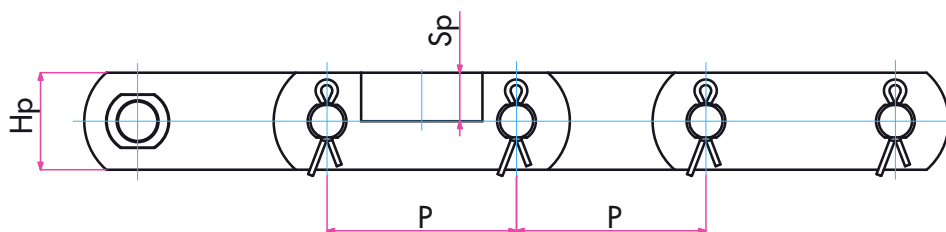

Codice/Code	Dimensioni / Dimensions													Carico medio di rottura / Average breaking load
	P	Li	Db	Dp	Hp	Si	Se	Im	F	La	lx	Sp	l	
781/SC	78,1	34	31,75	16,0	40	8	10	86	19,5	50	81	20	63	150
800/SC	80,0	34	27,94	15,9	45	6	8	69	22,0	50	82	18	57	190

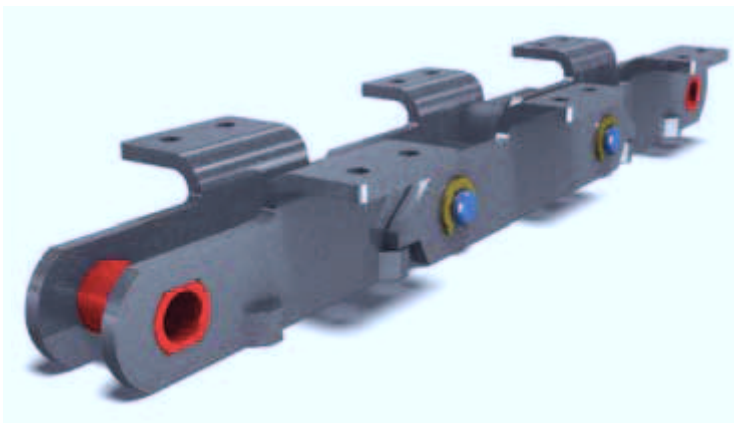
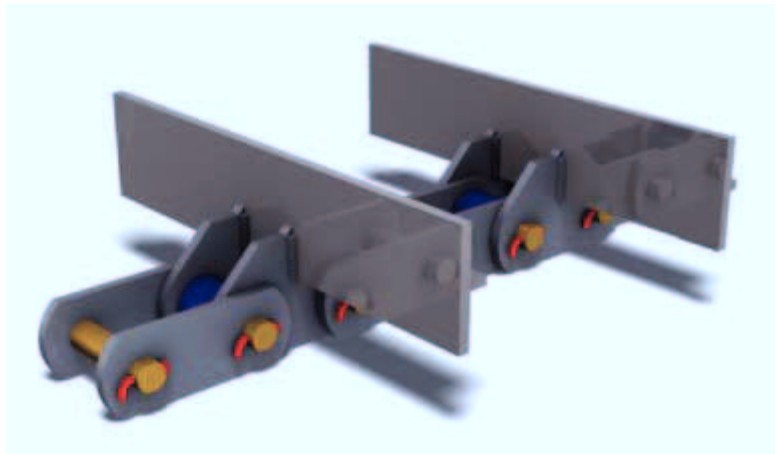
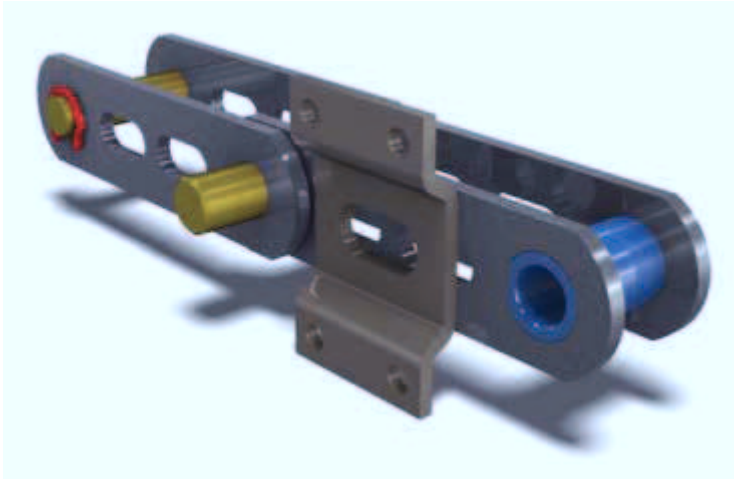





Mechanical Chains
SPECIAL CHAINS

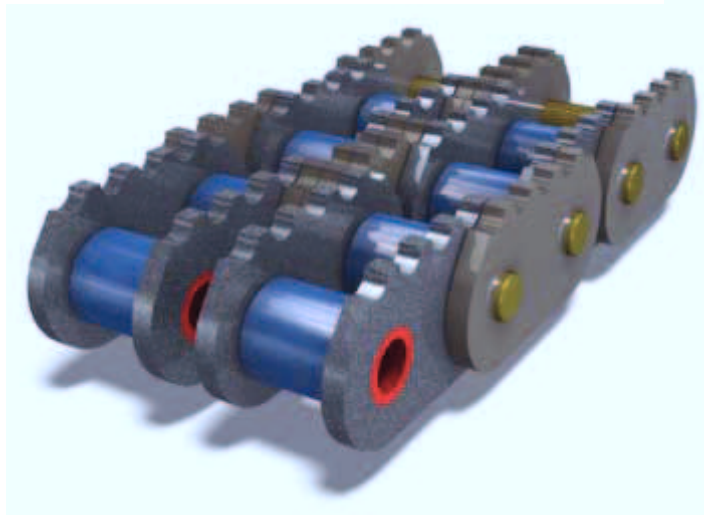
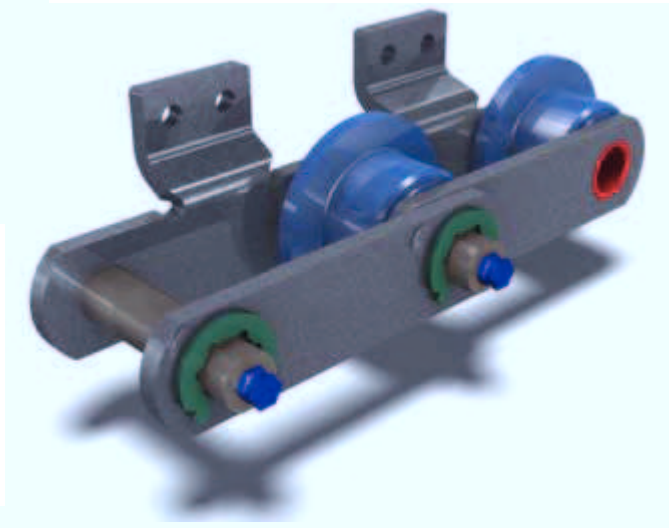
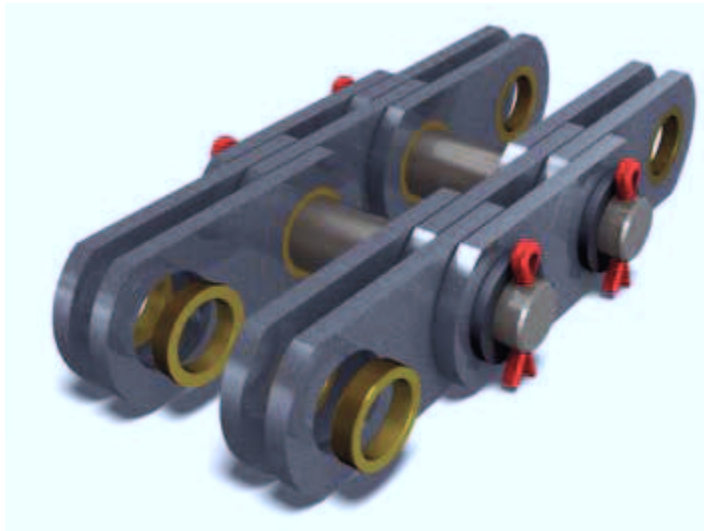
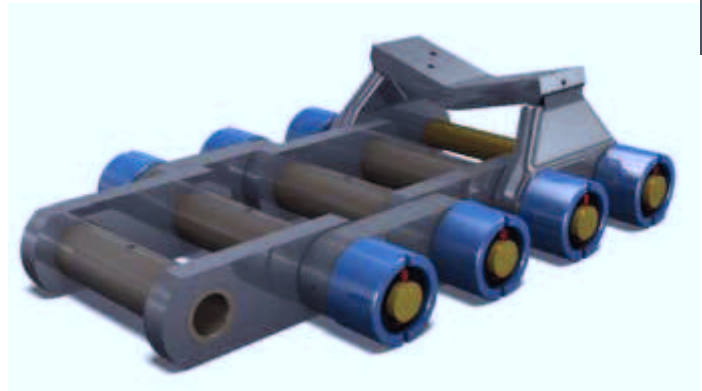

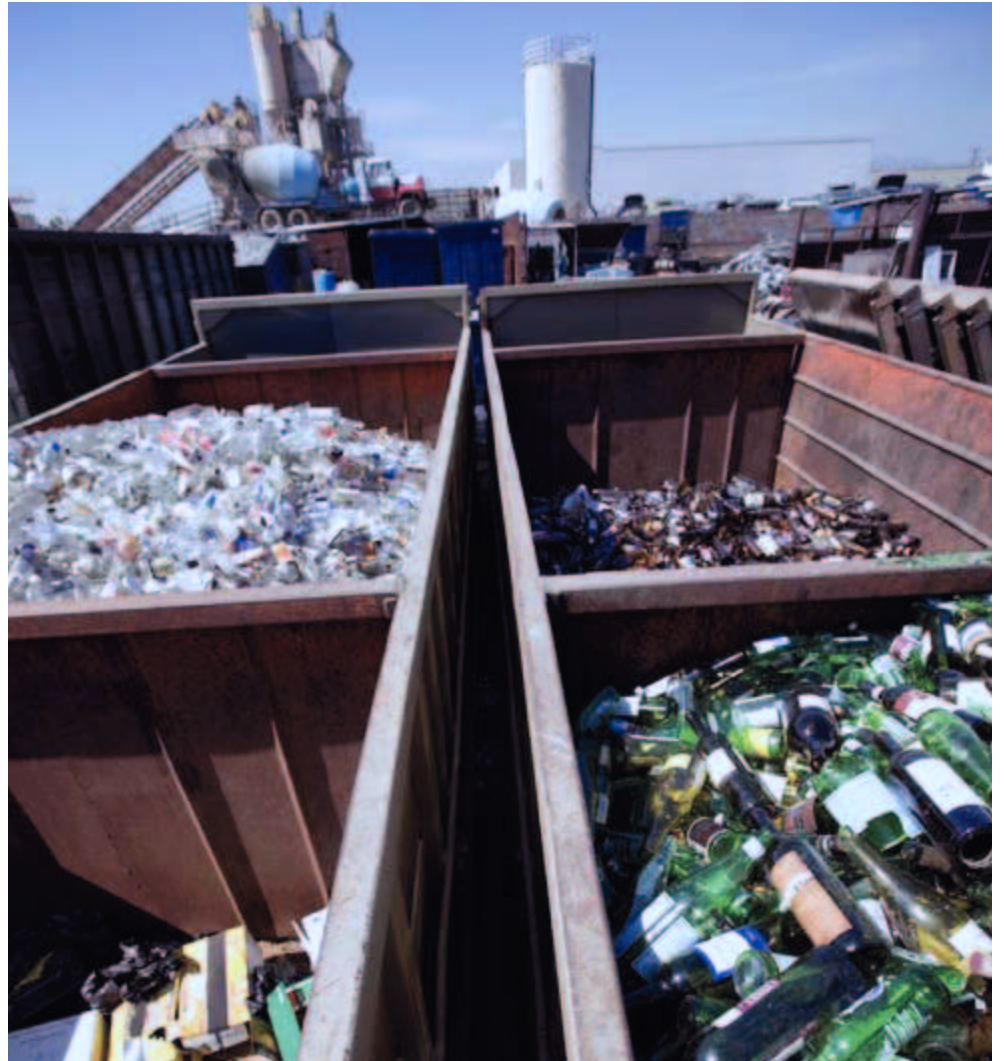



Mechanical Chains
SPECIAL CHAINS

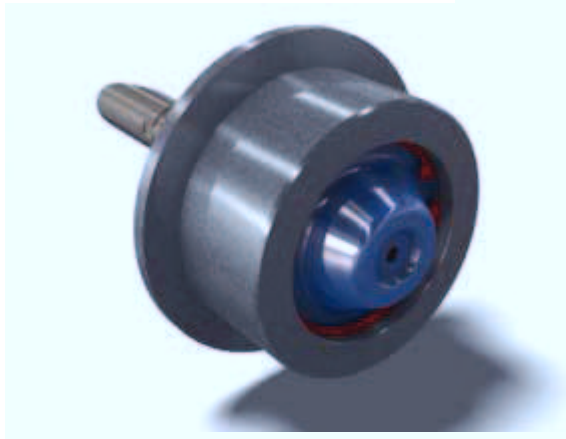
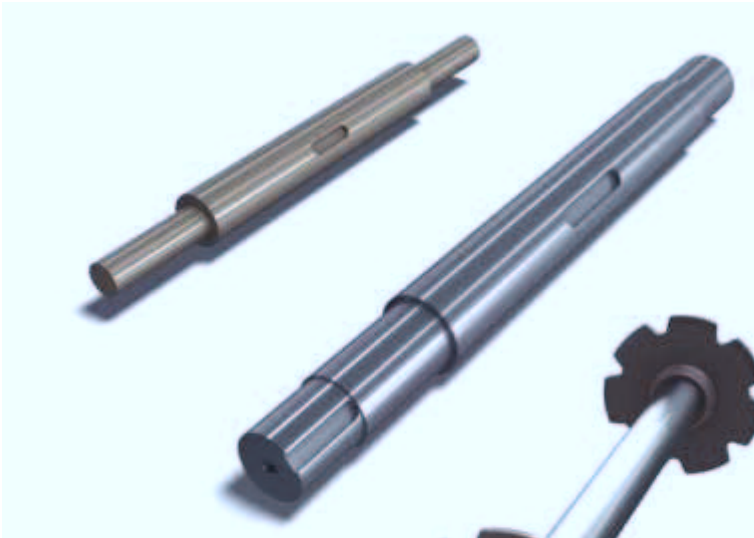

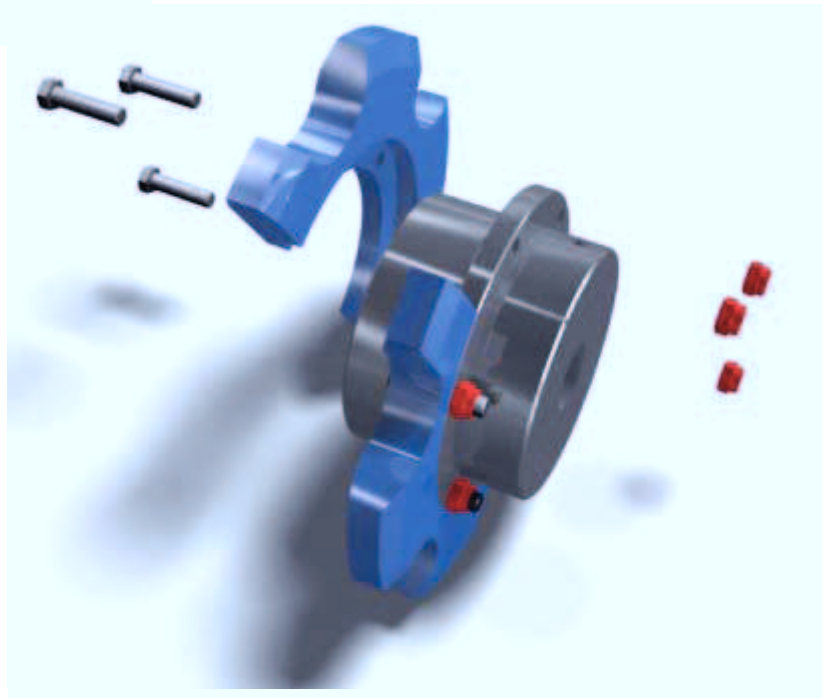

Altri prodotti MCV

Other MCV products

CATALOGO GENERALE
GENERAL CATALOGUE

CATENE MECCANICHE - CATENE TRASPORTO
MECHANICAL CHAINS - CONVEYOR CHAINS

1

To link for passion

MCV
To link for passion

CATALOGO GENERALE
GENERAL CATALOGUE

CATENE MAGLIE STAMPATE - CATENE RASCHIANTI A MAGLIE STAMPATE
CHAINS FORGED LINKS - SCRAPER CHAINS FORGED LINKS

CATENE MECCANICHE - CATENE RASCHIANTI A PIASTRE DIRITTE
MECHANICAL CHAINS - SCRAPER CHAINS STRAIGHT SIDEPLATES

2

To link for passion

MCV
To link for passion

CATALOGO GENERALE
GENERAL CATALOGUE

CATENE MECCANICHE - CATENE SPECIALI
MECHANICAL CHAINS - SPECIAL CHAINS

3

To link for passion

MCV
To link for passion

CATALOGO GENERALE
GENERAL CATALOGUE

CATENE MECCANICHE - CATENE PER TRASMISSIONE DI POTENZA E TRAZIONE
MECHANICAL CHAINS - POWER TRANSMISSION AND TRACTION CHAINS

4

To link for passion

MCV
To link for passion

1
CATENE MECCANICHE
CATENE TRASPORTO
MECHANICAL CHAINS
CONVEYOR CHAINS

2
CATENE MAGLIE STAMPATE
CATENE RASCHIANTI
A MAGLIE STAMPATE
CHAINS FORGED LINKS
SCRAPER CHAINS FORGED LINKS

CATENE MECCANICHE
CATENE RASCHIANTI
A PIASTRE DIRITTE
MECHANICAL CHAINS
SCRAPER CHAINS STRAIGHT
SIDEPLATES

3
CATENE MECCANICHE
CATENE SPECIALI
MECHANICAL CHAINS
SPECIAL CHAINS

4
CATENE MECCANICHE
CATENE PER TRASMISSIONE
DI POTENZA E TRAZIONE
MECHANICAL CHAINS
POWER TRANSMISSION AND
TRACTION CHAINS



Unità produttiva di Viganò Brianza
Production unit of Viganò Brianza



Unità produttiva di Missaglia
Production unit of Missaglia



To link for passion

Manifattura Catene Viganò M.C.V. Spa
Via dell'Industria, 11 - 23897 Viganò (LC) Italy
Tel. +39 039 92134.1 - Fax +39 039 92134.25
mcv.catene@mcvcatene.com - www.mcvcatene.com