

**HIMMEL® -**  
DRUM MOTORS

**HIMMEL®**  
technologies  
YOUR DRIVE FOR SUCCESS.



## **| WHO WE ARE**

HIMMEL® technologies – Eight companies from the fields of machine and drive technology, automation technology, plant engineering, water treatment and environmental technology are united under this umbrella.

The headquarters of the group of companies is located in Gescher - in the western Münsterland region. HIMMEL® technologies employs a total of approx. 350 people on a production area of over 35,000 m<sup>2</sup>.

The group of companies represents a wide range of expertise that more and more customers worldwide are relying on. Whether for the development of individual components or turnkey systems - the companies of HIMMEL® technologies offer solutions that are tailored to your individual requirements.

All companies work closely together to realize complex projects. The special feature: You always deal with the same contact person - from planning and production through assembly and commissioning to turnkey handover. This shortens decision-making processes and helps to ensure that your project is completed on time.

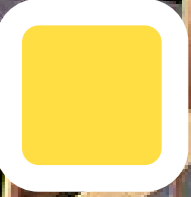

# LAT Maschinen- und Antriebstechnik GmbH & Co. KG

Founded in 1947, the company focuses on the drum motor, which has been used for decades with ever-growing success in many areas of conveyor technology. With diameters between 60 and 800 mm, we manufacture them both as

standard and as custom-made products. Due to its space-saving design and its good adaptability to individual conditions on site, it is constantly finding new areas of application.

This has made LAT one of the leading companies

in machine and drive technology. With numerous competent partners and agencies at home and abroad, we offer products and service for customers around the globe.

LAT also produces our world-renowned ELC852

servo-hydraulic high-speed pusher. This is a highly specialized niche product for the hollow glass industry for transporting sensitive glass bottles.

# CONTENTS



GENERAL INFORMATION

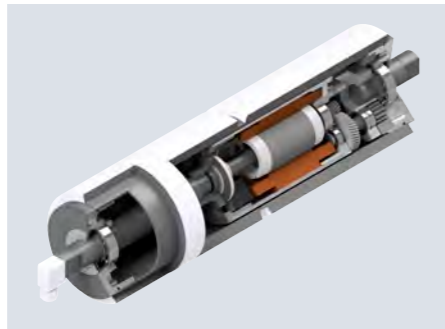
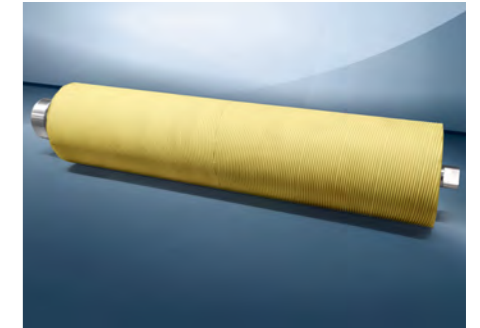

TECHNICAL EXPLANATIONS

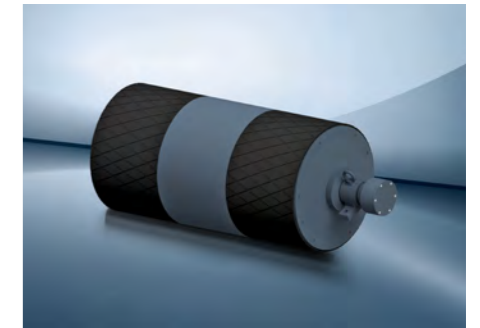
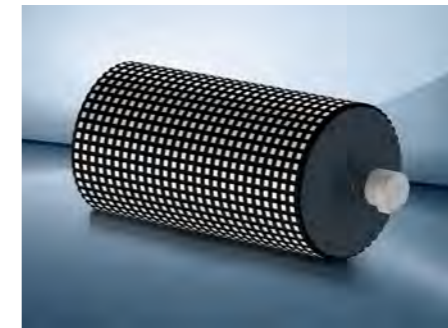
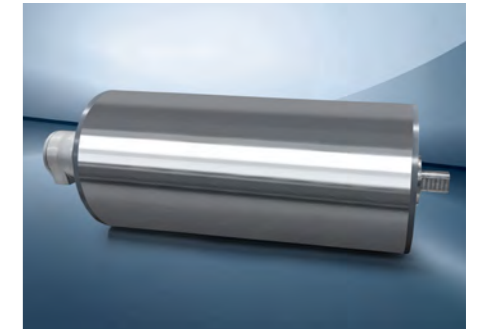
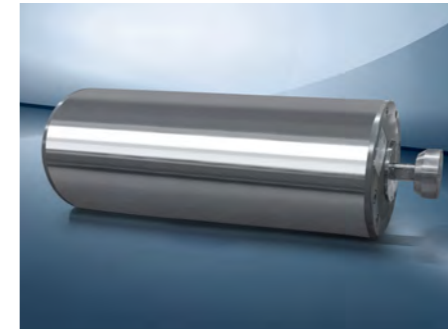
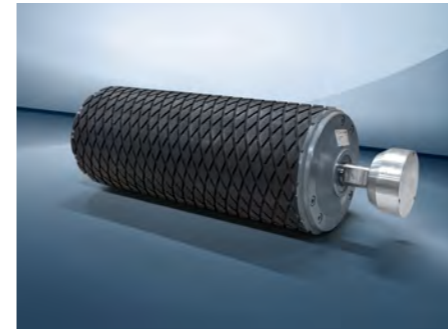

SIZE TM60

- | Dimension sheets
- | Overview of services
- | Execution types & options



SIZE TM82

- | Dimension sheets
- | Overview of services
- | Execution types & options

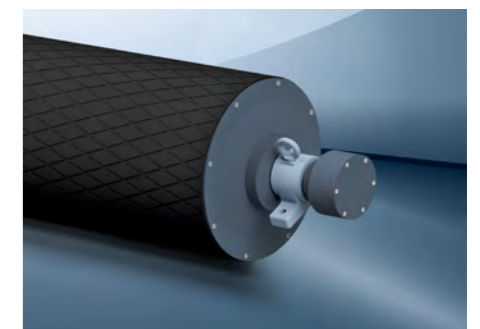
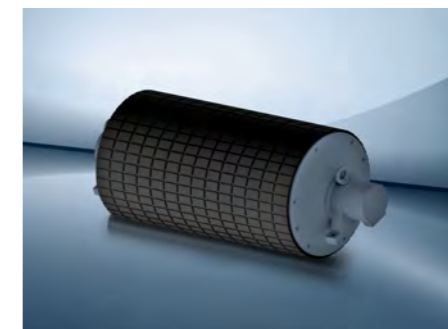
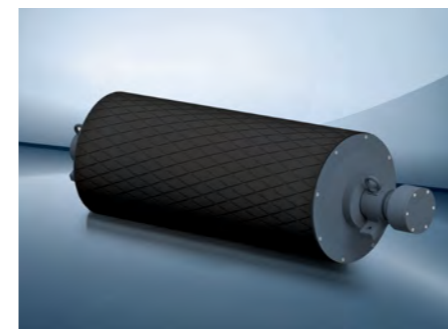



## WHAT SETS US APART

HIMMEL® drum motors are used to drive stationary or transportable conveyor belts for the transportation of all kinds of bulk goods; they are also used in beltless conveyor systems. Due to its space-saving design and its good adaptability to given operating conditions, the HIMMEL® drum motor has opened up more and more areas of

application in drive technology. HIMMEL® Drum Motors have been used successfully for decades in many areas of conveyor technology.

## CUSTOM-MADE PRODUCTS

HIMMEL® drum motors are available in various designs that can be adapted to suit the application and environment. In addition to the standard dimensions in the catalog, we can also offer special shafts and various special drum bodies for a wide range of customer requirements. Some of these are shown on pages (12 and 13) of the catalog. You will also find a selection of special designs that we can produce.

The winding design of our HIMMEL® drum motors can be adapted to special voltages and frequencies to enable the drives to be used worldwide.

Overall, our HIMMEL® drum motors therefore offer a high degree of flexibility and adaptability to different requirements and areas of application.

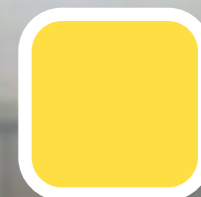

# GENERAL INFORMATION

## General information

### Mechanical structure

The electric motor and reduction gearbox are housed inside the drum shell and form a closed drive unit that is largely protected against external influences. Ample dimensioning of the individual parts ensures a long service life even under harsh operating conditions. State-of-the-art production methods ensure low-noise operation and high efficiency.

The clamping journals on both sides are flattened and enable simple and time-saving installation using two-part clamping bearings.

In all HIMMEL® drum motors, the power is supplied from the terminal box to the built-in electric motor through the hollow shaft clamping journal; the mains connection is made on the fixed terminal board, as with normal electric motors.

As there are no moving transmission elements subject to wear (slip rings, brushes), the power supply requires no maintenance.

### Protection class

HIMMEL® drum motors are manufactured in a fully enclosed design, dust-tight and protected against water jets to protection class IP65 or higher in accordance with DIN EN 60034-5 (IEC 60034-5); they are therefore suitable for use outdoors and in dusty or damp rooms.

### Magnetic brakes

HIMMEL® drum motors in oil-cooled design can be supplied with a magnetic brake at an extra charge.

HIMMEL® drum motors with brakes are used when it is not desirable for the drum to run on after being switched off.

The HIMMEL® TM82 to TM620 drum motors can be supplied with an internal brake.

The HIMMEL® TM630 to TM800 drum motors can be supplied with an external brake shaft.

If HIMMEL® drum motors are supplied with an internal electromagnetic brake, the minimum widths of the drums increase; see selection table.

### Drive motors

Normally, these are three-phase asynchronous motors with special slotted rotors, which give the HIMMEL® drum motor the desired high starting torque with maximum operational safety.

### Operating voltage

The HIMMEL® drum motors are supplied in the standard voltages 230 V, 400 V at 50 Hz and can be operated in accordance with DIN EN 60034 (IEC 60034) without changing the rated power if the rated voltage fluctuates. Voltages and frequencies deviating from this require an additional charge. The type of starting (direct or star/delta or with frequency inverter) must be specified when ordering. The motors are designed with a cable

lead-out or a terminal box. The motors can be connected in a delta or star configuration using the appropriate wiring. For star/delta starting, the operating voltage must be specified; in this case, the operating circuit of the motor must be the delta circuit.

Operating voltage 400 V delta: Motor winding 400/690 V Operating voltage 230 V delta: Motor winding 230/400 V. In many cases, star/delta connection is not possible because, for example, loaded conveyor belts require a starting torque; with star/delta connection, only 1/3 of the starting torque is available compared to direct connection.

### Frequency

All listed specifications refer to a mains frequency of 50 Hz. At other frequencies, the speed and therefore also the belt speed changes in proportion to the frequency.

### Insulation of the motor winding

The winding and insulation of the standard version of HIMMEL® drum motors comply with insulation class F in accordance with DIN EN 60034-1 (IEC 60034-1) (maximum permissible temperature 155 °C)

### HIMMEL® drum motors for the North American market

HIMMEL® drum motors in sizes TM60-TM165 are also available in the cCSAus version.

### Motor protection

For an additional charge, HIMMEL® drum motors can be equipped with winding protection contacts (WT) or with PTC thermistor temperature sensors (PTC) to protect the motor winding from impermissible heating.

### HIMMEL® drum motors with pole-changing built-in motors

By installing pole-changing motors, HIMMEL® drum motors can be manufactured for several belt speeds. For corresponding inquiries, we request precise details of the required power and corresponding belt speeds as well as the available mains voltage.

# GENERAL INFORMATION

## Program overview



Drum diameter		Power range			Belt speed			
		P <sub>2</sub> [kW]			V [m/s]			
	[mm]	See page	Minimum	Maximum	Minimum	Maximum		
Ø	60	20	0,03	→	0,08	0,09	→	1,90
Ø	82	25	0,018	→	0,12	0,03	→	0,97
Ø	113	30	0,075	→	0,55	0,09	→	3,47
Ø	138	37	0,09	→	1,00	0,04	→	2,73
Ø	165	44	0,37	→	3,0	0,19	→	5,18
Ø	216	49	0,37	→	3,0	0,25	→	2,20
Ø	321	54	1,5	→	7,5	0,39	→	3,28
Ø	415	59	3,0	→	15	0,60	→	2,17
Ø	518	63	4,0	→	22	0,51	→	2,14
Ø	620	67	7,5	→	22	0,77	→	2,56
Ø	630	72	30	→	55	1,25	→	4,00
Ø	800	75	22	→	132	1,00	→	4,50
Ø	1000	78	160	→	250	1,60	→	9,50

\* on request

## GENERAL INFORMATION

### Application examples for HIMMEL® drum motors



Standard HIMMEL® drum motor



Examples of positive drive belts

#### Drum shell

HIMMEL® drum motors are designed with a crowned drum shell. The corresponding dimensions can be found in the dimension sheet (dimension D2 and D1).

#### Drum lagging

In the standard version, HIMMEL® drum motors are supplied without rubber laggings.

On request, HIMMEL® drum motors can be supplied with rubber linings or ceramic friction linings where this is thermally possible.

#### Rubber coverings

HIMMEL® drum motors can be supplied with different rubber laggings. The exact lagging thickness depends on the drum diameter:

Cold glued:

- 3-4 mm smooth for TM113-TM138
  - 5 mm smooth from TM165
  - 8 mm diamond profile from TM165
  - 10 mm diamond profile from TM518
  - 2 mm food-resistant dimpled profile hot-vulcanized according to customer requirements.
- The increased circumferential speed must be taken into account.

## GENERAL INFORMATION

### Application examples for HIMMEL® drum motors



TM with round brush



TM with multiple crowning



TM as screw conveyor



TM with coating and center keyway



TM with sprocket

#### Ceramic friction linings

HIMMEL® drum motors can also be designed with ceramic friction linings. The ceramic friction lining is applied to the drum shell and has a lining thickness of approx. 3-5 mm.

The rubber or ceramic friction lining increases the drum diameter by 2x the lining thickness. The circumferential speed increases accordingly.

#### Special versions

All special versions deviating from the list specifications require longer delivery times and additional prices.

- Winding for deviating frequencies between 40 and 60 Hz (normal 50 Hz)
- Winding for deviating voltage (normal up to 2.2 kW 400 V star, from 3.0 kW 400 V delta)

- Winding for deviating voltage and frequency
- Thermal protection of the winding by installing winding protection contacts (WT) or PTC thermistor temperature sensors (PTC)
- Corrosion protection (rust or acid protection coating of the metal parts)
- Pole switching
- Increased ambient temperature (normal up to 40 °C)
- Rubber coverings, ceramic friction lining
- Cylindrical drum shell
- Clamping spigot round or other dimensions
- Labyrinth seal, gap seal
- Backstop, brake
- Rotary encoder on request

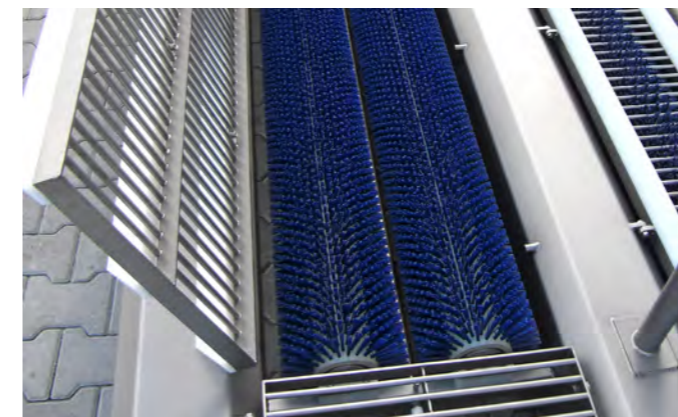

## APPLICATION EXAMPLES



Drum motors with sprockets for driving modular conveyor belts

## APPLICATION EXAMPLES



Drum motors in fish processing

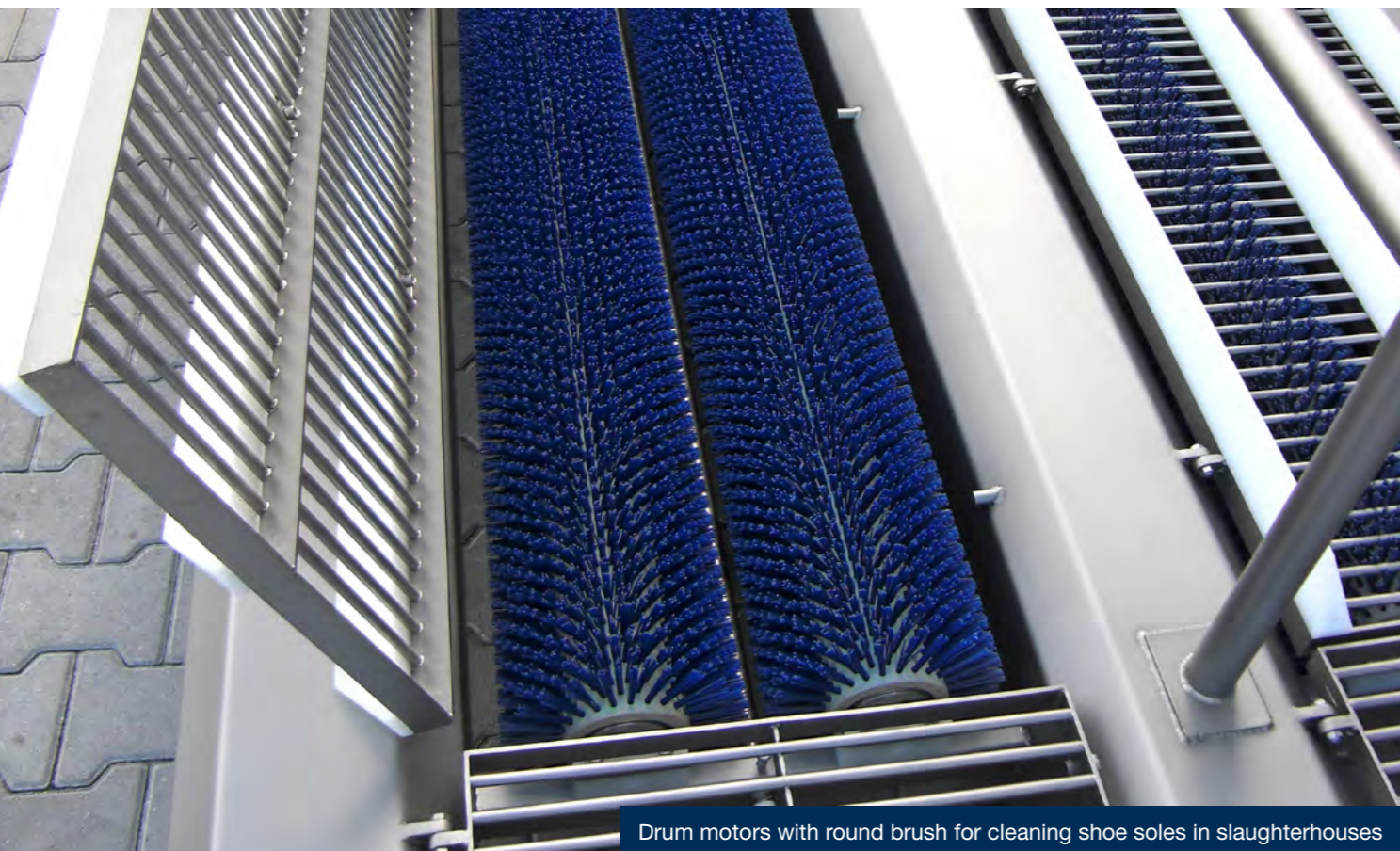

Drum motors with round brush for cleaning shoe soles in slaughterhouses



Drum motors for the food sector



## APPLICATION EXAMPLES



Drum motors in wood processing



Drum motors in the furniture industry

## APPLICATION EXAMPLES

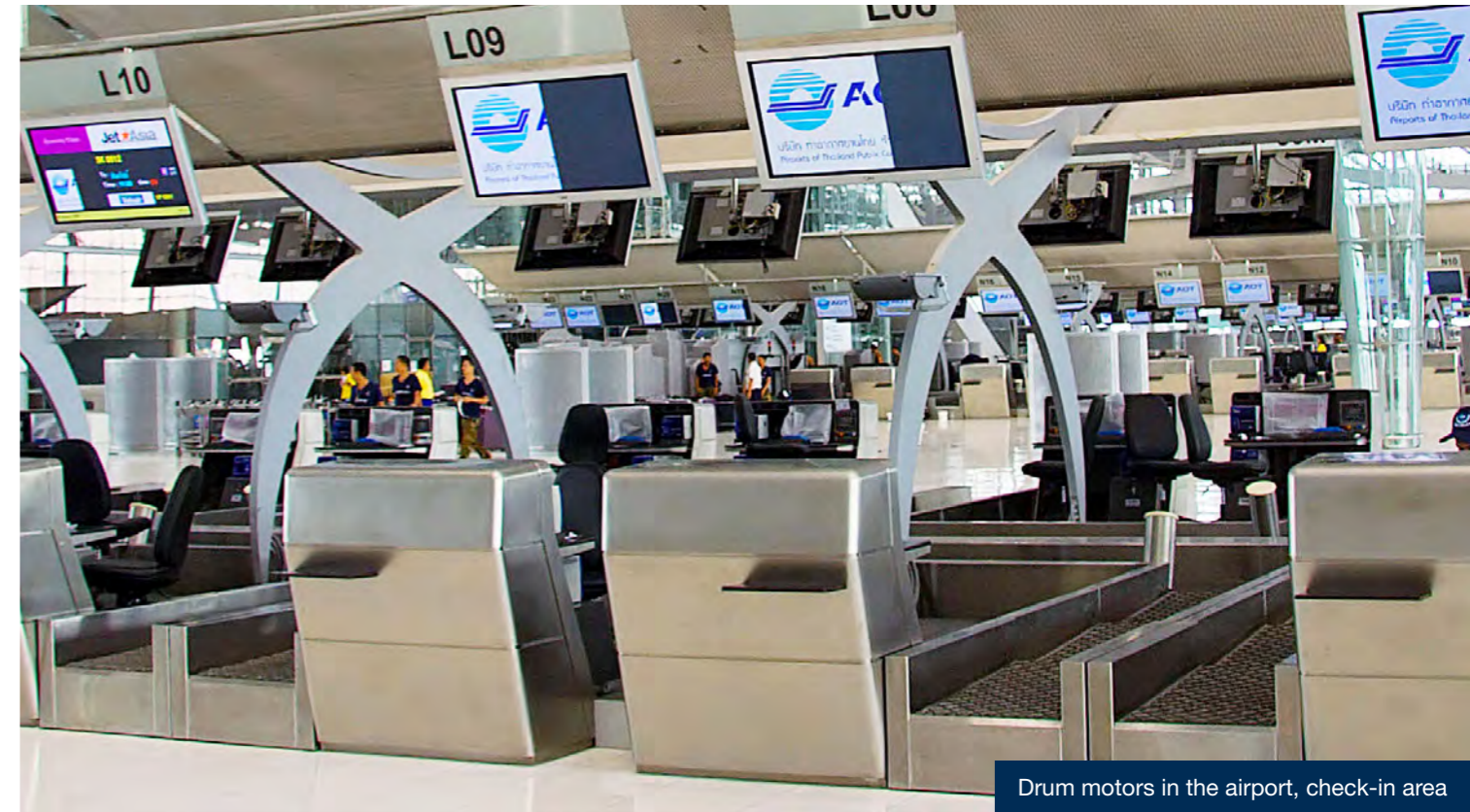

Drum motors in the airport, check-in area



Drum motors for the production of railroad sleepers

## APPLICATION EXAMPLES



Drum motors in the packaging industry



Drum motors in the packaging industry

## APPLICATION EXAMPLES

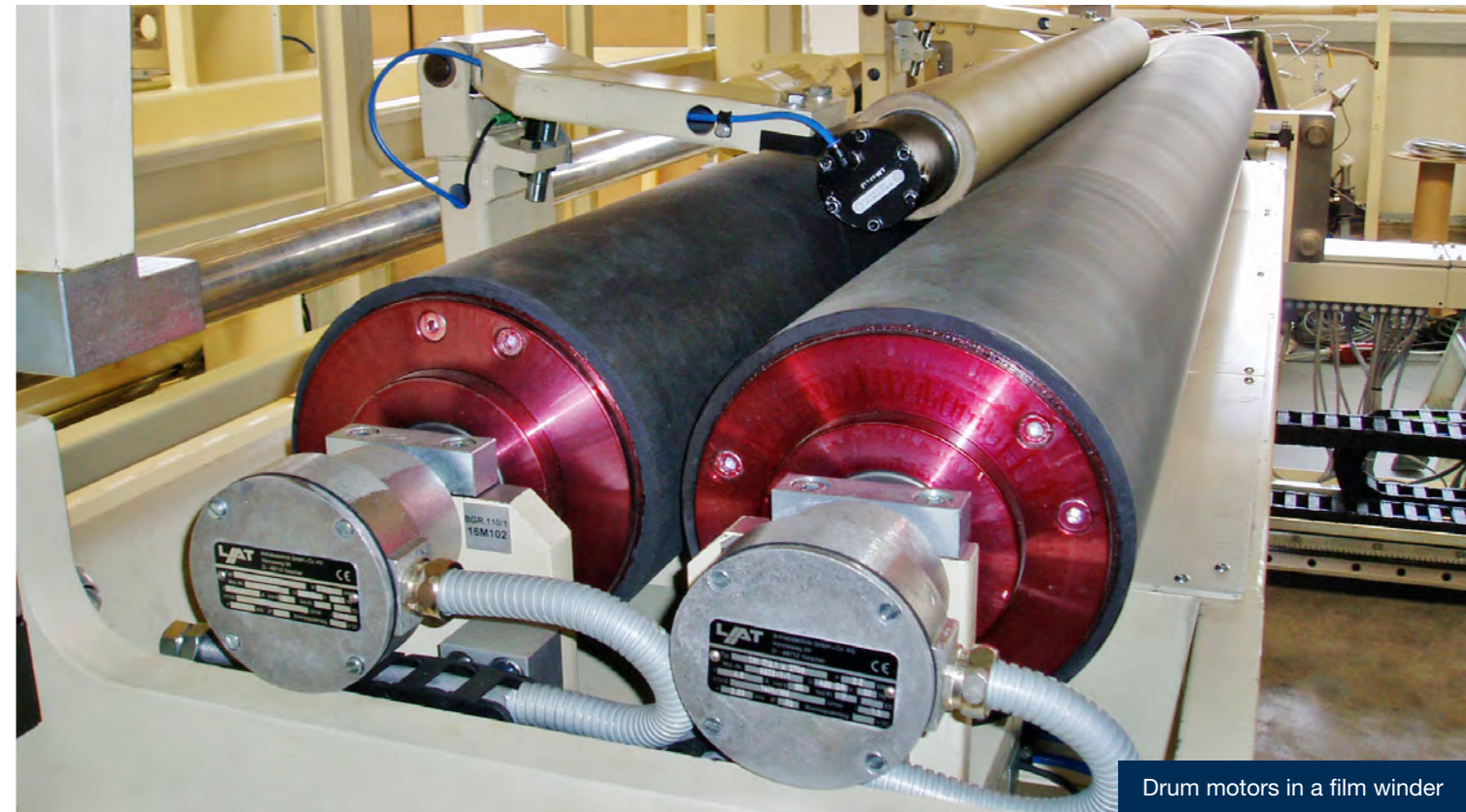

Drum motors in a film winder



Drum motors in a screening machine

## MODEL SERIES TM60.1

### Drum motor TM60, standard

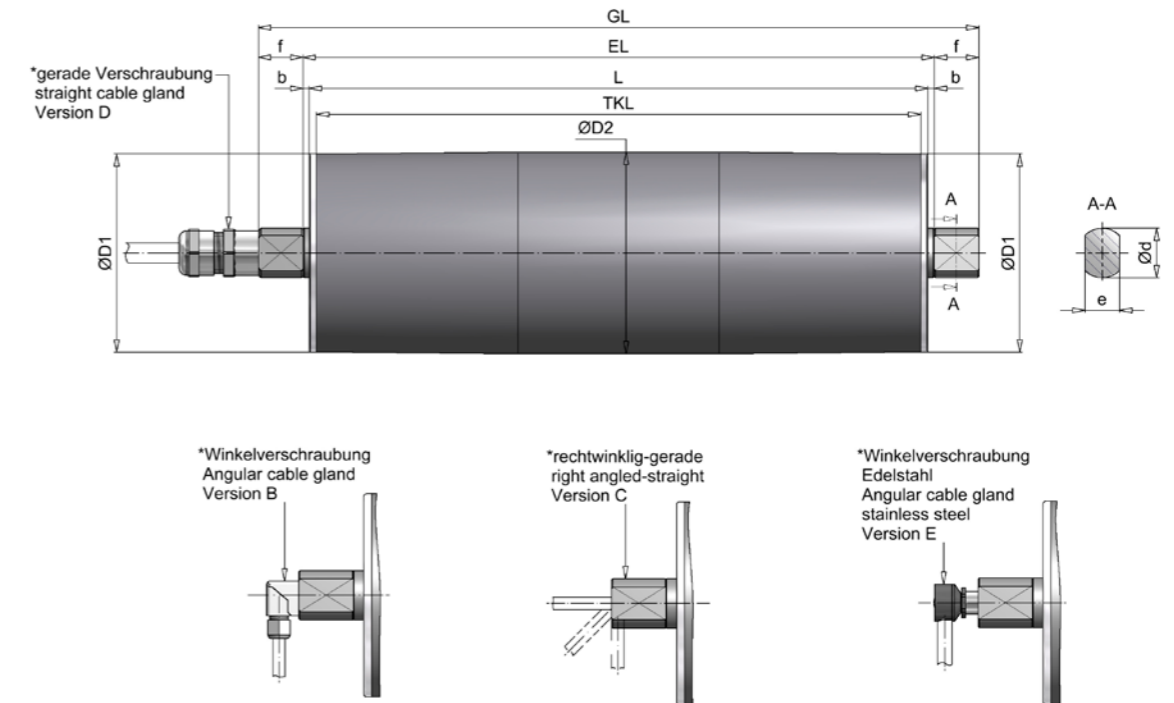

### deflection drum UT60, standard

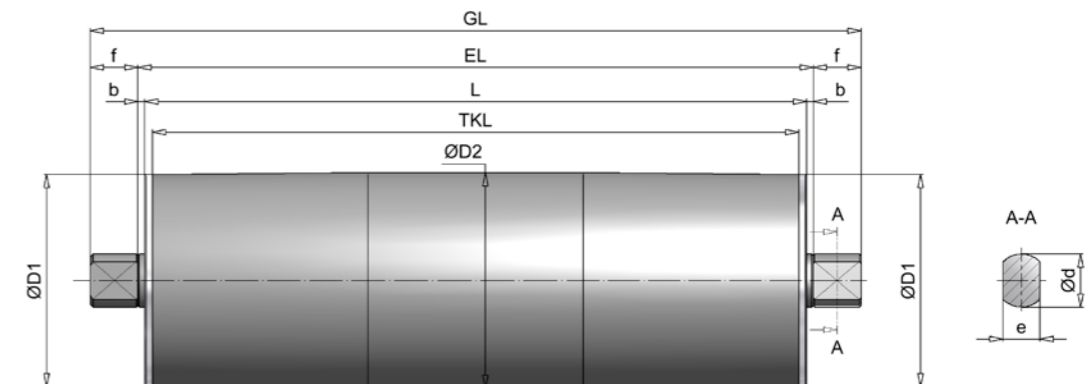

all dimensions in mm

HIMMEL <sup>®</sup> drum motor			Standard IP65							
Size	Material	Type	Ø D1	Ø D2	Ø d	e	f	TKL	b	EL
60	Steel	TM60.1	61,5	62,5	20	14	18	L - 6	2,5	L + 5
	Stainless steel		63,5	64,5						
HIMMEL <sup>®</sup> deflection drum										
60	Steel	UT60.1	61,5	62,5	20	14	18	L - 6	2,5	L + 5
	Stainless steel		63,5	64,5						

\* with 3 m cable

Diameter for cylindrical drum body: steel  $\text{Ø} 62.5$ ; stainless steel  $\text{Ø} 64$

## MODEL SERIES TM60

# MODEL SERIES TM60

## Overview of services

Type	Performance	Speed	Rotational speed	Belt tension	Drum torque	Power consumption at 400 V / 50 Hz	Drum length L min.	Weight
	P2	v	n2	F	T2			L=450 mm
	[kW]	[m/s]	[1/min]	[N]	[Nm]			[A]
TM60.1	0,03 4-pole	0,09	26	345	11	0,19	355 with IP65 365 with IP66	6
		0,11	34	265	8			
		0,14	41	219	7			
		0,15	45	204	6			
		0,18	54	168	5			
		0,22	65	139	4			
		0,59	178	51	2			
		0,76	232	39	1			
0,92	280	32	1					
TM60.1	0,08 2-pole	0,18	54	447	14	0,24	355 with IP65 365 with IP66	6
		0,23	71	343	11			
		0,28	85	284	9			
		0,30	92	264	8			
		0,37	111	218	7			
		0,44	134	180	6			
		1,21	366	66	2			
		1,57	477	51	2			
		1,90	576	42	1			

- Different performance data and speeds on request
- Weight incl. oil filling (ready for operation)
- Additional weight: approx. 0.5 kg per 100 mm additional length

Standard widths [L] : 355, 365, 400, 450 ... 800 mm, from 800 mm reinforced version

# MODEL SERIES TM60

## Execution types and options

Standard version	Options
<ul style="list-style-type: none"> <li>• spherically turned steel jacket, bright steel, coated with rust protection</li> <li>• IP65</li> <li>• Aluminum bearing end caps</li> <li>• Clamping spigot made of steel, coated with rust protection</li> <li>• Planetary gearbox with steel gearing</li> <li>• Straight screw connection (incl. 3 m cable)</li> </ul>	<ul style="list-style-type: none"> <li>• Elbow fitting (with 3 m cable)</li> <li>• Stainless steel elbow fitting (with 3 m cable)</li> <li>• Right-angled straight screw connection (with 3 m cable)</li> <li>• Sprocket/toothed belt pulley</li> <li>• Cylindrical drum body, galvanized (customer-specific)</li> <li>• Stainless steel version</li> <li>• IP66</li> <li>• Suitable for frequency inverter operation</li> <li>• for plastic modular belts</li> <li>• Vertical installation possible</li> <li>• Food oil</li> <li>• HIMMEL® drum motor as built-in cartridge</li> <li>• Single-phase alternating current motors on request</li> <li>• cCSAus</li> </ul> <p>Other versions available on request.</p>

## Clamping bearing for HIMMEL® drum motor / HIMMEL® deflection drum type 60

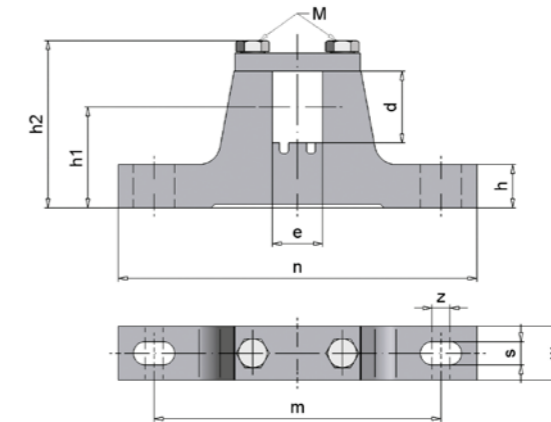

all dimensions in mm

Drum type	Clamping bearing	d	e	h	h1	h2	m	n	s	w	z	M	Material	approx. kg
TM/UT60.1	EL20/14	20	14	12	28	47	80	100	6,5	15	5	M5	Steel	0,25

Color of the clamping bearings in RAL 7031

# MODEL SERIES TM60

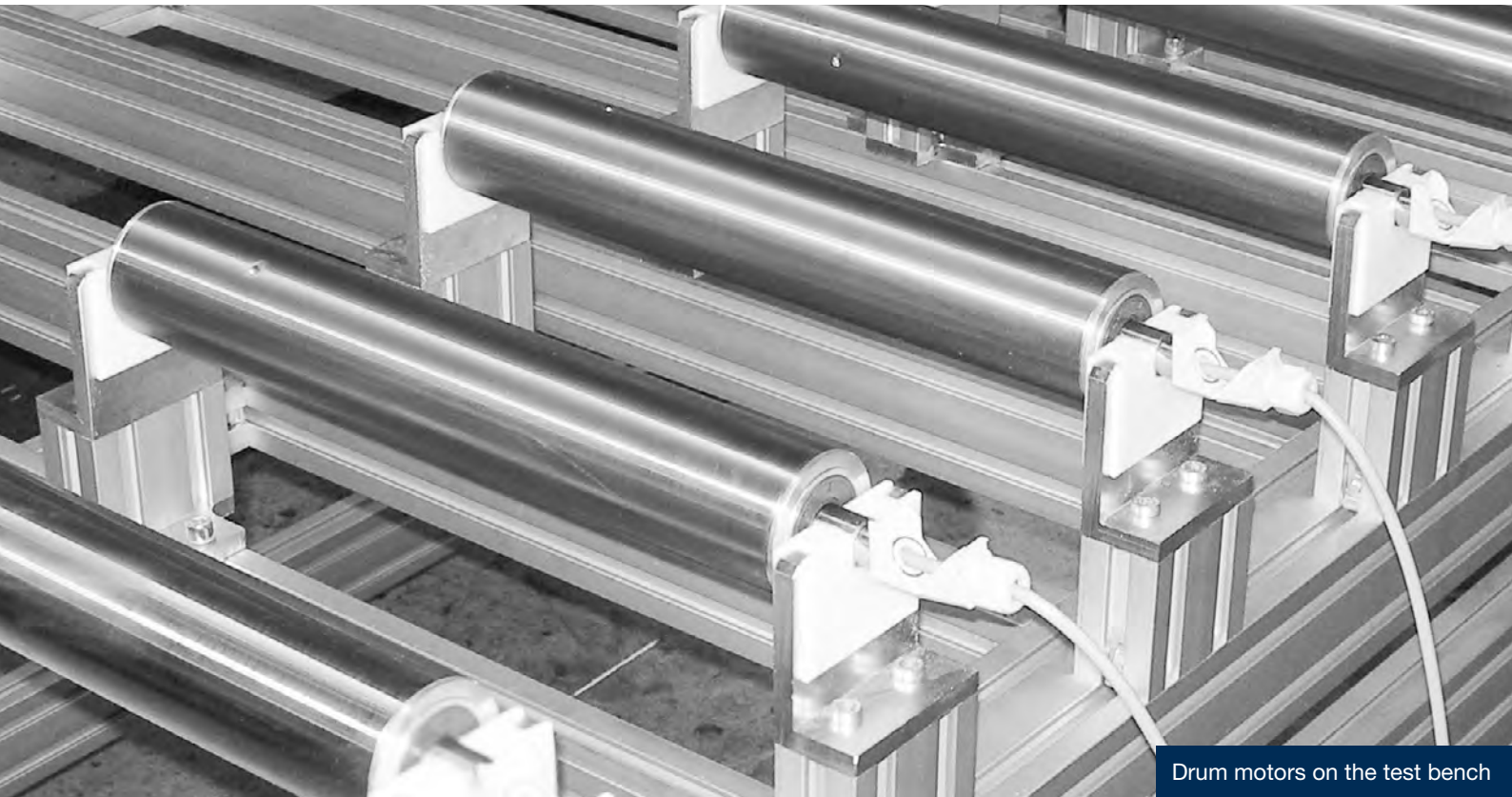

Drum motors on the test bench

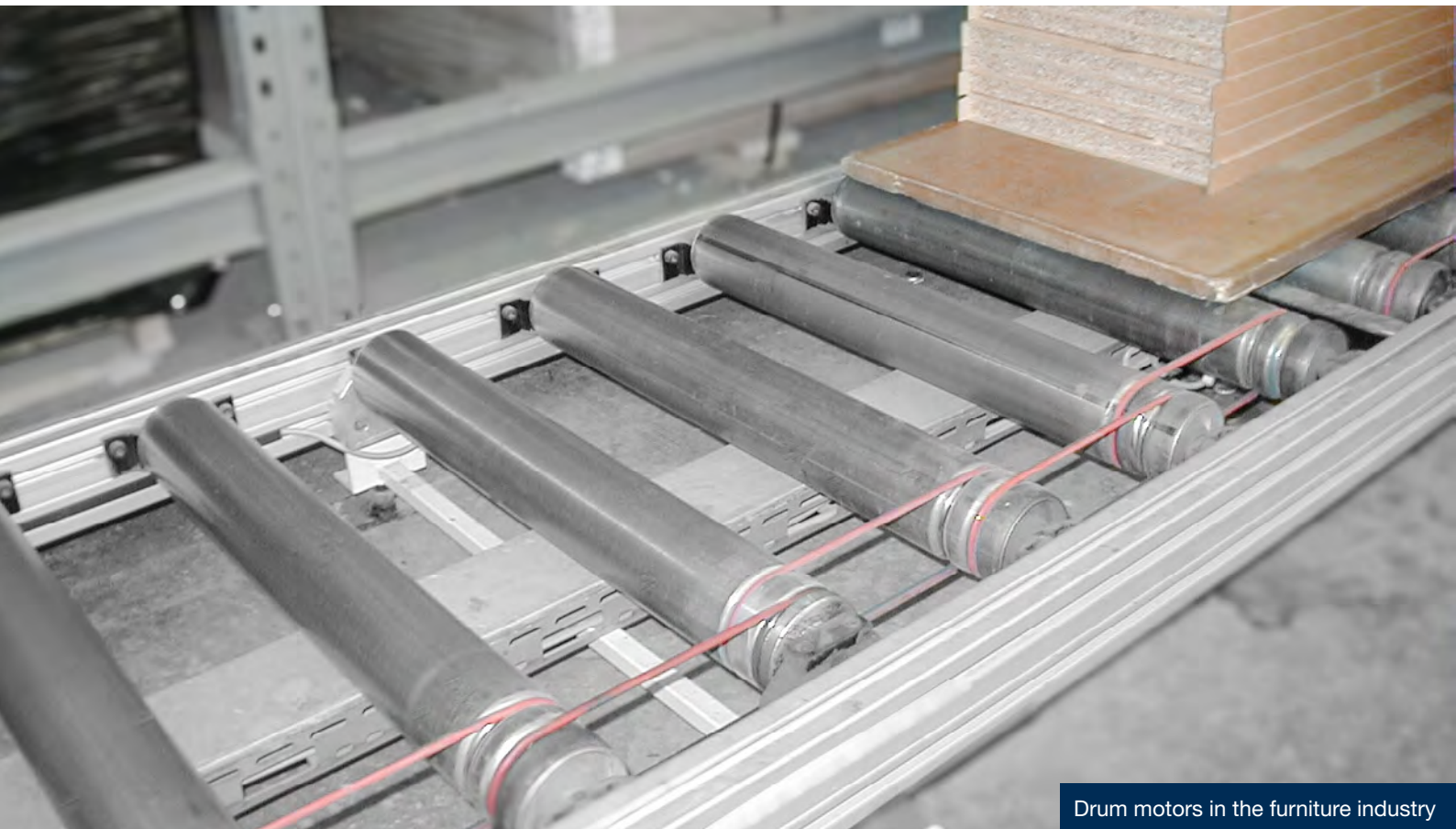

Drum motors in the furniture industry



**| MODEL SERIES TM82**

# MODEL SERIES TM82

## Drum motor TM82, standard

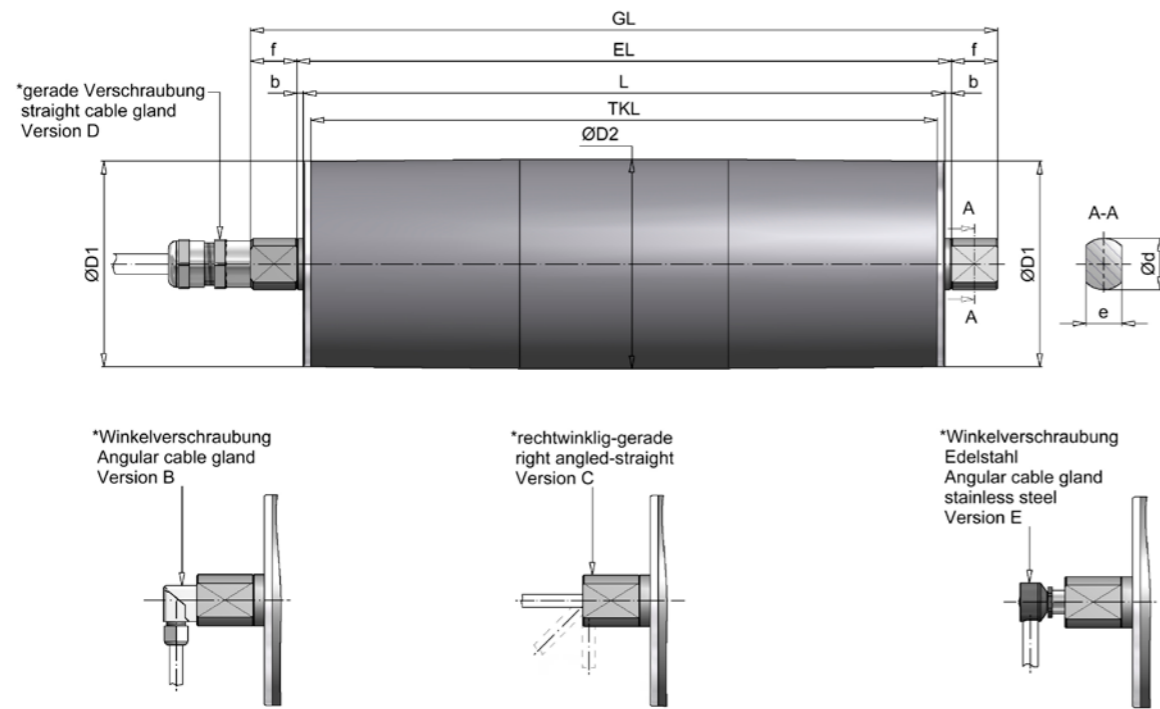

## deflection drum UT82, standard

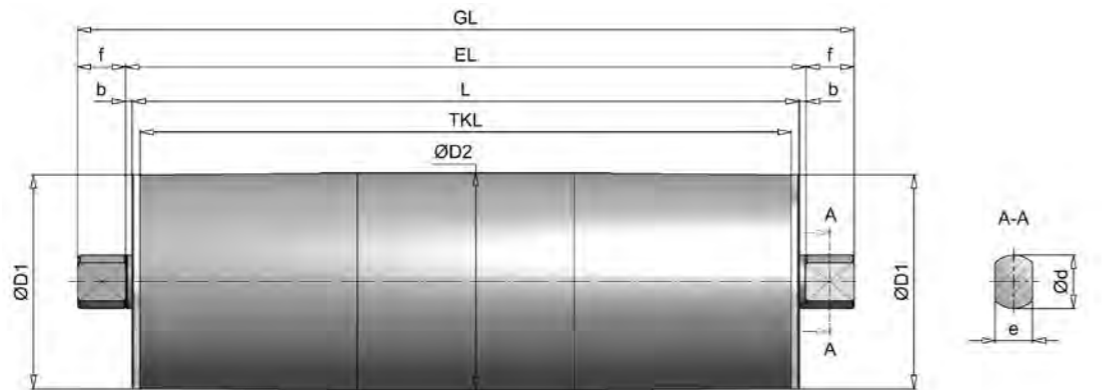

all dimensions in mm

HIMMEL® drum motor												
Size	Type	Ø D1**	Ø D2**	a	Ø N	Ø d	e	f	f1	TKL	b	EL
82	TM82.1	80	81,5			20	14	18		L - 6	2,5	L + 5

HIMMEL® deflection drum												
Size	Type	Ø D1**	Ø D2**	a	Ø N	Ø d	e	f	f1	TKL	b	EL
82	UT82.1	80	81,5			20	14	18		L - 6	2,5	L + 5

\* with 3 m cable

\*\* Diameter with cylindrical drum body Ø 81 mm

# MODEL SERIES TM82

## Overview of services

Type	Performance	Speed	Rotational speed	Belt tension	Drum torque	Power consumption at 400 V / 50 Hz	Drum length L min.	Weight
	[kW]	[m/s]	[1/min]	[N]	[Nm]			
TM82.1	0,018 8-pole	0,03	8	537	22	0,18	IP66 250 IP67 250 IP69K 280	4,5
		0,05	11	375	15			
		0,06	14	305	12			
		0,09	20	209	9			
		0,12	29	146	6			
TM82.1	0,04 4-pole	0,15	36	119	5	0,23	IP66 200 IP67 200 IP69K 240	3,5
		0,08	19	482	20			
		0,10	22	419	17			
		0,14	32	292	12			
		0,17	39	238	10			
		0,25	58	163	7			
TM82.1	0,07 2-pole	0,35	83	114	5	0,20	IP66 200 IP67 200 IP69K 240	3,5
		0,43	101	93	4			
		0,18	43	384	16			
		0,21	49	334	14			
		0,30	70	233	9			
		0,37	87	190	8			
TM82.1	0,07 4-pole	0,54	126	130	5	0,37	IP66 250 IP67 250 IP69K 280	4,5
		0,77	181	91	4			
		0,95	222	74	3			
		0,08	20	827	34			
		0,10	23	718	29			
		0,14	33	501	20			
TM82.1	0,12 2-pole	0,17	40	408	17	0,31	IP66 250 IP67 250 IP69K 280	4,5
		0,25	59	279	11			
		0,36	84	195	8			
		0,44	103	159	6			
		0,19	43	647	26			
		0,21	50	562	23			
		0,31	72	392	16			
0,38	88	319	13					
0,55	129	218	9					
0,79	185	152	6					
0,97	227	124	5					

- Deviating performance data and speeds on request
- Weight incl. oil filling (ready for operation)
- Additional weight: approx. 0.8 kg for 100 mm additional length
- The L min. dimension increases by 100 mm when the brakes are fitted

Standard widths [L] : 200, 250, 300, 350 ... 800 mm, above 800 mm please contact us

## MODEL SERIES TM82

### Execution types and options

Standard version
<ul style="list-style-type: none"> <li>spherically turned steel jacket, bright steel, coated with rust protection</li> <li>IP66</li> <li>Aluminum bearing end caps</li> <li>Clamping spigot made of steel, coated with rust protection</li> <li>Spur gearbox with steel gearing (low-noise)</li> <li>Straight screw connection (incl. 3 m cable)</li> </ul>

Options
<ul style="list-style-type: none"> <li>Internal brake</li> <li>Elbow fitting (with 3 m cable)</li> <li>Stainless steel elbow fitting (with 3 m cable)</li> <li>Right-angled straight screw connection (with 3 m cable)</li> <li>Backstop (ball bearing freewheel)</li> <li>Sprocket/toothed belt pulley</li> <li>Sensor bearing unit (rotary encoder)</li> <li>Cylindrical drum body, rubberized, galvanized</li> <li>(customer-specific)</li> <li>Stainless steel version</li> <li>Thermal contacts</li> <li>IP67</li> <li>IP69K</li> <li>Suitable for frequency inverter operation</li> <li>for plastic modular belts and profile rubberizing</li> <li>Vertical installation possible (specify when ordering)</li> <li>Food oil</li> <li>HIMMEL® drum motor as built-in cartridge</li> <li>Single-phase alternating current motors on request</li> <li>cCSAus</li> </ul>
Other versions available on request.

### Clamping bearing for HIMMEL®-drum motor / HIMMEL® deflection drum type 82

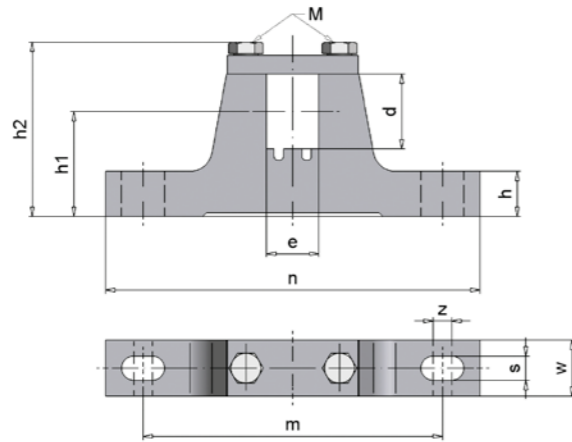

all dimensions in mm

Drum type	Clamping bearing	d	e	h	h1	h2	m	n	s	w	z	M	Material	approx. kg
TM/UT82.1	EL20/14	20	14	12	28	47	80	100	6,5	15	5	M5	Steel	0,25

Color of the clamping bearings in RAL 7031

## MODEL SERIES TM82







**| MODEL SERIES TM113**

# MODEL SERIES TM113

## Drum motor TM113, standard

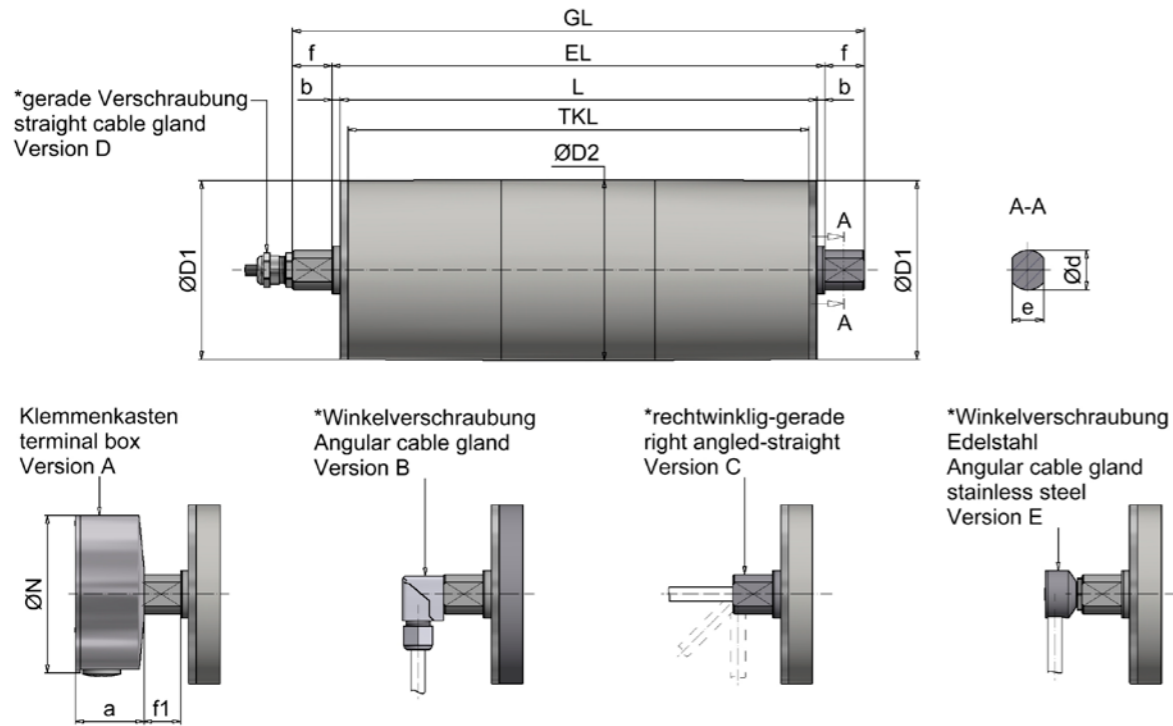

## Deflection drum UT113, standard

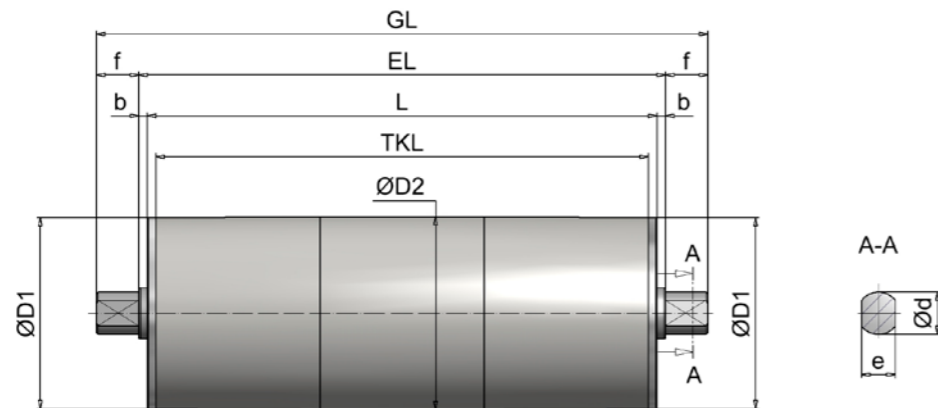

all dimensions in mm

HIMMEL® drum motor												
Size	Type	Ø D1**	Ø D2**	a	Ø N	Ø d	e	f	f1	TKL	b	EL
113	TM113.1	112,5	113,5	43	100	25	20	25	23	L - 10	5	L + 10

HIMMEL® deflection drum												
Size	Type	Ø D1**	Ø D2**	a	Ø N	Ø d	e	f	f1	TKL	b	EL
113	TM113.1	112,5	113,5			25	20	25		L - 10	5	L + 10

\* with 3 m cable

\*\* Diameter with cylindrical drum body 113

# MODEL SERIES TM113

## Overview of services

Type	Performance	Speed	Rotational speed	Belt tension	Drum torque	Power Consumption at 400 V / 50 Hz	Drum length L min.	Weight
	P2	v	n2	F	T2			
	[kW]	[m/s]	[1/min]	[N]	[Nm]	[A]	[mm]	[kg]
TM113.1	0,075 8-pole	0,09	16	795	45	0,45	IP66 260 IP67 260 IP69K 305	12,5
		0,12	19	650	37			
		0,14	23	541	31			
		0,16	28	456	26			
		0,19	33	388	22			
		0,23	38	333	19			
		0,26	44	286	16			
		0,28	47	271	15			
		0,34	57	221	13			
		0,41	68	184	10			
		0,48	81	155	9			
		0,57	95	132	8			
0,66	111	113	6					
0,77	129	98	6					
TM113.1	0,12 6-pole	0,14	23	876	50	0,57	IP66 260 IP67 260 IP69K 305	12,5
		0,17	28	716	41			
		0,20	34	596	34			
		0,24	40	503	29			
		0,28	47	428	24			
		0,33	55	367	21			
		0,38	64	316	18			
		0,40	68	299	17			
		0,49	83	244	14			
		0,59	99	203	12			
		0,70	118	171	10			
		0,82	138	146	8			
0,96	162	125	7					
1,11	188	108	6					
TM113.1	0,18 4-pole	0,21	36	845	48	0,68	IP66 260 IP67 260 IP69K 305	12,5
		0,26	44	690	39			
		0,31	53	575	33			
		0,37	63	485	27			
		0,44	73	413	23			
		0,51	86	354	20			
		0,59	99	304	17			
		0,63	105	288	16			
		0,76	129	235	13			
		0,92	155	196	11			
		1,09	183	165	9			
		1,28	215	141	8			
		1,49	251	121	7			
		1,73	292	104	6			

# MODEL SERIES TM113

## Performance data

Type	Performance	Speed	Rotational speed	Belt tension	Drum torque	Power consumption at 400 V / 50 Hz	Drum length L min.	Weight
	P2	v	n2	F	T2			L=400 mm
	[kW]	[m/s]	[1/min]	[N]	[Nm]			[A]
TM113.1	0,25 4-pole	0,21	36	1173	67	0,94	IP66 260 IP67 260 IP69K 305	12,5
		0,26	44	959	54			
		0,31	53	798	45			
		0,37	63	673	38			
		0,44	73	573	33			
		0,51	86	491	28			
		0,59	99	423	24			
		0,63	105	400	23			
		0,76	129	327	19			
		0,92	155	272	15			
		1,09	183	229	13			
		1,28	215	195	11			
		1,49	251	167	10			
		1,73	292	144	8			
TM113.1	0,30 4-pole	0,21	36	1408	80	1,10	IP66 280 IP67 280 IP69K 325	13,6
		0,26	44	1151	65			
		0,31	53	958	54			
		0,37	63	808	46			
		0,44	73	688	39			
		0,51	86	589	33			
		0,59	99	507	29			
		0,63	105	480	27			
		0,76	129	392	22			
		0,92	155	326	19			
		1,09	183	275	16			
		1,28	215	234	13			
		1,49	251	201	11			
		1,73	292	173	10			
TM113.1	0,37 2-pole	0,43	72	868	49	0,95	IP66 260 IP67 260 IP69K 305	12,5
		0,52	88	710	40			
		0,63	105	591	34			
		0,74	125	498	28			
		0,87	147	424	24			
		1,02	171	363	21			
		1,18	199	313	18			
		1,25	210	296	17			
		1,53	257	242	14			
		1,84	309	201	11			
		2,18	367	170	10			
		2,56	431	145	8			
		2,99	503	124	7			
		3,47	584	107	6			

# MODEL SERIES TM113

## Performance data

Type	Performance	Speed	Rotational speed	Belt tension	Drum torque	Power consumption at 400 V / 50 Hz	Drum length L min.	Weight
	P2	v	n2	F	T2			L=400 mm
	[kW]	[m/s]	[1/min]	[N]	[Nm]			[A]
TM113.1	0,55 2-pole	0,42	71	1300	74	1,26	IP66 280 IP67 280 IP69K 325	13,6
		0,52	87	1062	60			
		0,62	105	884	50			
		0,74	124	746	42			
		0,87	146	635	36			
		1,01	170	544	31			
		1,17	198	469	27			
		1,24	209	443	25			
		1,52	256	362	21			
		1,82	307	301	17			
		2,16	364	254	14			
		2,54	428	216	12			
		2,97	499	185	11			
		3,44	579	160	9			

- Deviating performance data and speeds on request
  - Weight incl. oil filling (ready for operation)
  - Additional weight: approx. 1 kg per 100 mm additional length
  - The L min. dimension increases by 65 mm when the brakes are fitted
- Standard widths [L] : 260, 280, 310, 360 ... 810 mm from 810 mm reinforced version.**

## MODEL SERIES TM113

### Execution types and options

Standard version
<ul style="list-style-type: none"> <li>spherically turned steel jacket, bright steel, coated with rust protection</li> <li>IP66</li> <li>Aluminum bearing end caps</li> <li>Clamping spigot made of steel, coated with rust protection</li> <li>Spur gearbox with steel gearing (low-noise)</li> <li>Straight screw connection (incl. 3 m cable)</li> </ul>

Options
<ul style="list-style-type: none"> <li>Internal brake</li> <li>with terminal box</li> <li>Elbow fitting (with 3 m cable)</li> <li>Right-angled straight screw connection (with 3 m cable)</li> <li>Backstop (ball bearing freewheel)</li> <li>Sprocket/toothed belt pulley</li> <li>Sensor bearing unit (rotary encoder)</li> <li>Cylindrical drum body, rubberized, galvanized (customized)</li> <li>Stainless steel version</li> <li>Thermal contacts</li> <li>IP67</li> <li>IP69K</li> <li>Suitable for frequency inverter operation</li> <li>for plastic modular belts and profile rubberizing</li> <li>Terminal box design in stainless steel</li> <li>Vertical installation possible (specify when ordering)</li> <li>Food oil</li> <li>HIMMEL® drum motor as built-in cartridge</li> <li>Single-phase alternating current motors on request</li> <li>cCSAus</li> </ul>
Other versions available on request.

### Clamping bearing for HIMMEL®-drum motor / HIMMEL® deflection drum type 113

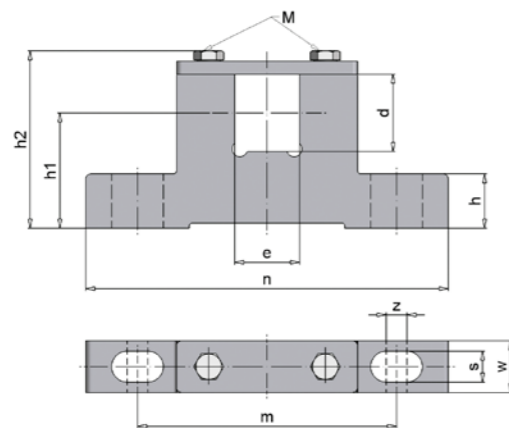

all dimensions in mm

Drum type	Clamping bearing	d	e	h	h1	h2	m	n	s	w	z	M	Material	approx. kg
TM113.1	EL25/20	25	20	21	44,5	66	100	140	12	20	8	M6	Steel	0,7

Color of the clamping bearings in RAL 7031

## MODEL SERIES TM113

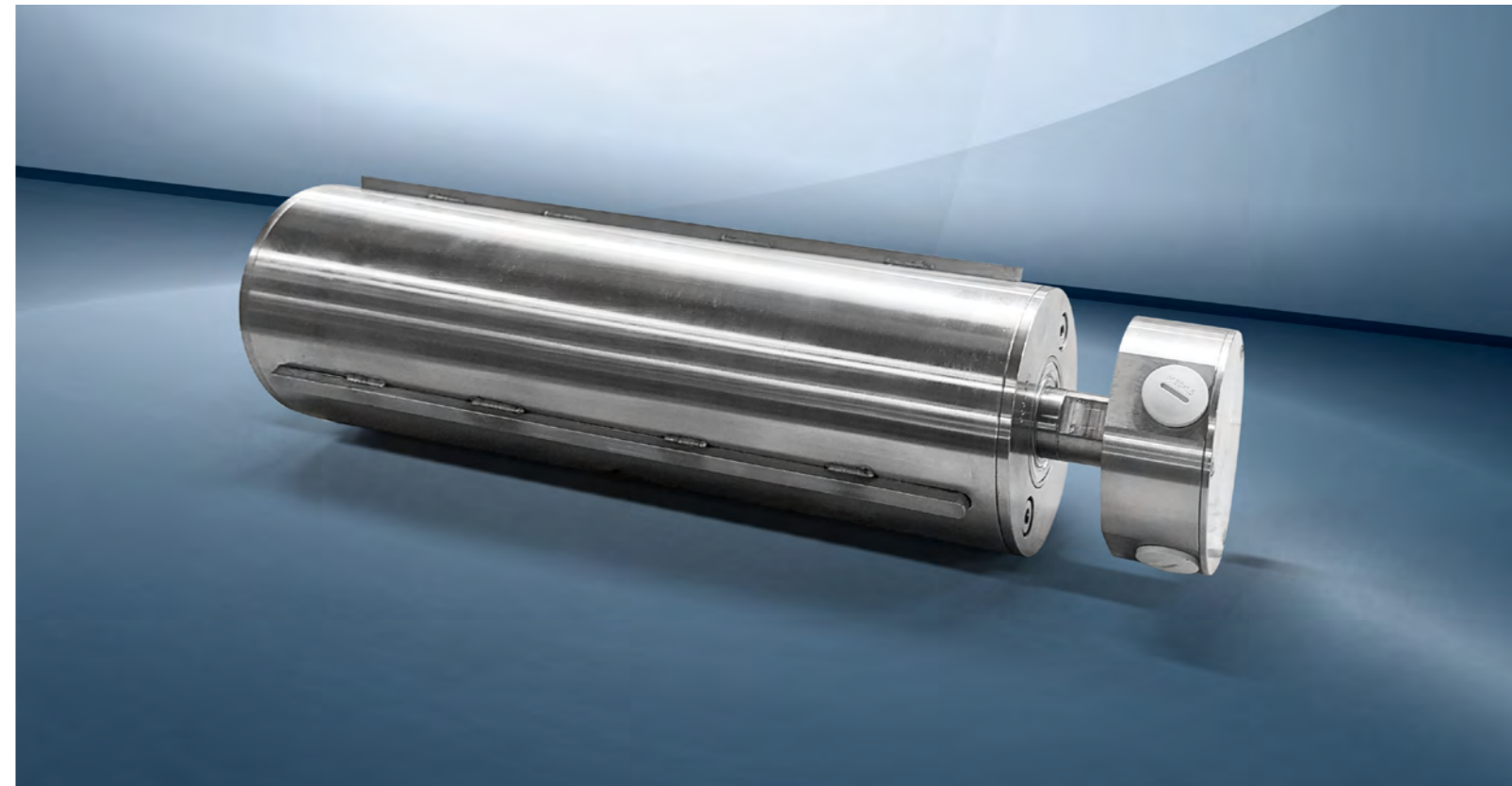



**| MODEL SERIES TM138**

# MODEL SERIES TM138

## Drum motor TM138, standard

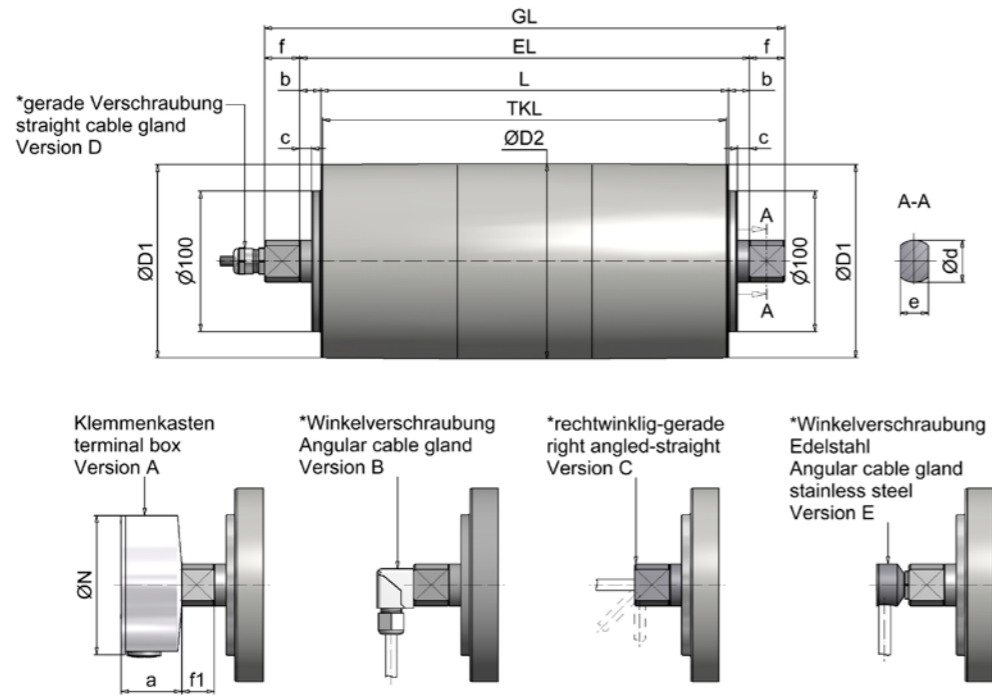

## deflection drum UT138, standard

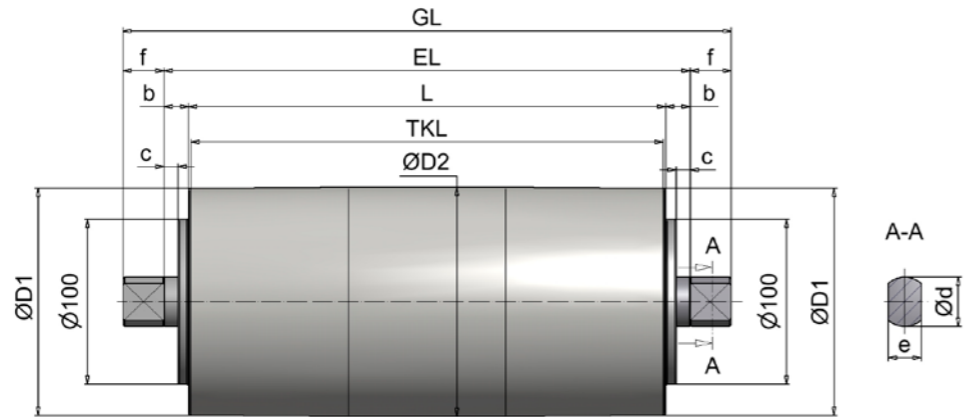

all dimensions in mm

HIMMEL® drum motor													
Size	Type	Ø D1	Ø D2**	a	Ø N	c	Ø d	e	f	f1	TKL	b	EL
138	TM138.1	137,5	139	43	100	8,5	30	20	25	23	L - 3	15	L + 30
HIMMEL® deflection drum													
138	UT138.1	137,5	139			8,5	30	20	25		L - 3	15	L + 30

\* with 3 m cable

\*\* Diameter with cylindrical drum body 138 mm

# MODEL SERIES TM138

## Overview of services

Type	Performance	Speed	Rotational speed	Belt tension	Drum torque	Power consumption at 400 V / 50 Hz	Drum length L min.	Weight	
	P2	v	n2	F	T2				L=400 mm
	[kW]	[m/s]	[1/min]	[N]	[Nm]				[A]
TM138.1	0,09 12-pole	0,04	6	2218	153	0,82	IP66 300 IP67 300 IP69K 320	15	
		0,05	7	1797	124				
		0,06	8	1478	102				
		0,07	9	1362	94				
		0,075	10	1198	83				
		0,08	11	1093	75				
		0,1	14	908	63				
		0,11	15	826	57				
		0,12	17	728	50				
		0,15	21	591	41				
		0,16	23	550	38				
		0,19	26	497	33				
TM138.1	0,18 8-pole	0,07	9	2739	189	0,80	IP66 300 IP67 300 IP69K 320	15	
		0,08	11	2219	153				
		0,1	14	1826	126				
		0,11	15	1683	116				
		0,12	17	1480	102				
		0,13	18	1350	93				
		0,16	22	1122	77				
		0,18	24	1020	70				
		0,2	28	900	62				
		0,25	34	731	50				
		0,26	37	680	47				
		0,3	42	592	41				
0,4	56	449	31						
0,5	69	360	25						
0,66	92	272	19						
TM138.1	0,25 6-pole	0,09	12	2782	192	0,85	IP66 300 IP67 300 IP69K 320	15	
		0,11	15	2254	156				
		0,13	19	1855	128				
		0,15	20	1709	118				
		0,17	23	1503	104				
		0,18	25	1371	95				
		0,22	30	1139	79				
		0,24	33	1036	71				
		0,27	38	914	63				
		0,34	47	742	51				
		0,36	50	691	48				
		0,42	58	601	41				
0,55	76	456	31						
0,68	95	366	25						
0,91	125	276	19						

# MODEL SERIES TM138

## Overview of services

Type	Performance	Speed	Rotational speed	Belt tension	Drum torque	Power consumption at 400 V / 50 Hz	Drum length L min.	Weight
	P2	v	n2	F	T2			L=400 mm
	[kW]	[m/s]	[1/min]	[N]	[Nm]			[A]
TM138.1	0,25 4-pole	0,14	19	1848	128	0,80	IP66 300 IP67 300 IP69K 320	15
		0,17	23	1497	103			
		0,2	28	1232	85			
		0,22	30	1135	78			
		0,25	35	998	69			
		0,27	38	911	63			
		0,33	46	757	52			
		0,35	50	688	47			
		0,41	57	607	42			
		0,51	70	493	34			
		0,55	75	459	32			
		0,63	87	399	28			
		0,83	114	303	21			
		1,03	143	243	17			
1,36	189	183	13					
TM138.1	0,37 4-pole	0,14	19	2735	189	1,10	IP66 300 IP67 300 IP69K 320	15
		0,17	23	2216	153			
		0,2	28	1823	126			
		0,22	30	1680	116			
		0,25	35	1477	102			
		0,27	38	1348	93			
		0,33	46	1120	77			
		0,36	50	1018	70			
		0,41	57	898	62			
		0,51	70	729	50			
		0,55	75	679	47			
		0,63	87	591	41			
		0,83	114	448	31			
		1,03	143	359	25			
1,36	189	271	19					
TM138.1	0,55 4-pole	0,2	28	2740	189	1,60	IP66 300 IP67 300 IP69K 320	15
		0,22	30	2525	174			
		0,25	34	2220	153			
		0,27	38	2025	140			
		0,33	45	1683	116			
		0,36	50	1530	106			
		0,41	56	1350	93			
		0,5	69	1096	76			
		0,54	75	1020	70			
		0,62	86	888	61			
		0,82	113	673	46			
		1,02	141	540	37			
		1,35	187	408	28			

# MODEL SERIES TM138

## Overview of services

Type	Performance	Speed	Rotational speed	Belt tension	Drum torque	Power consumption at 400 V / 50 Hz	Drum length L min.	Weight
	P2	v	n2	F	T2			L=400 mm
	[kW]	[m/s]	[1/min]	[N]	[Nm]			[A]
TM138.1	0,75 4-pole	0,32	44	2338	161	2,20	IP66 300 IP67 300 IP69K 320	15
		0,35	49	2125	147			
		0,4	55	1875	129			
		0,49	68	1522	105			
		0,53	73	1417	98			
		0,61	84	1233	85			
		0,8	111	935	65			
		1	138	750	52			
		1,32	183	566	39			
		TM138.1	0,75 2-pole	0,27	37			
0,33	46			2270	157			
0,4	56			1868	129			
0,44	60			1721	119			
0,5	69			1513	104			
0,54	75			1381	95			
0,65	90			1148	79			
0,72	99			1043	72			
0,81	113			920	64			
1	139			747	52			
1,08	149			696	48			
1,24	171			605	42			
1,63	226			459	32			
2,04	282			368	25			
2,7	373	278	19					
TM138.1	0,90 2-pole	0,33	46	2695	186	1,95	IP66 300 IP67 300 IP69K 320	15
		0,41	56	2218	153			
		0,44	61	2044	141			
		0,5	69	1797	124			
		0,55	76	1639	113			
		0,66	91	1362	94			
		0,73	101	1239	85			
		0,82	114	1093	75			
		1,01	140	887	61			
		1,09	151	826	57			
		1,25	173	719	50			
		1,65	229	545	38			
		2,06	285	437	30			
2,73	377	330	23					

# MODEL SERIES TM138

## Overview of services

Type	Performance	Speed	Rotational speed	Belt tension	Drum torque	Power consumption at 400 V / 50 Hz	Drum length L min.	Weight
	P <sub>2</sub>	v	n <sub>2</sub>	F	T <sub>2</sub>			L=400 mm
	[kW]	[m/s]	[1/min]	[N]	[Nm]			[kg]
TM138.1	1,00 4-pole	0,4	56	2241	155	2,6	IP66 360 IP67 360 IP69K 390	15
		0,49	68	1820	126			
		0,53	74	1694	117			
		0,61	85	1474	102			
		0,81	111	1118	77			
		1	139	897	62			
		1,33	184	677	47			

- Deviating performance data and speeds on request
- Weight incl. oil filling (ready for operation)
- Additional weight: approx. 2 kg per 100 mm additional length
- The L min. dimension increases by 100 mm for brake attachment

Standard widths [L] : 300, 350, 400 ... 1000 mm from 1000 mm reinforced version.

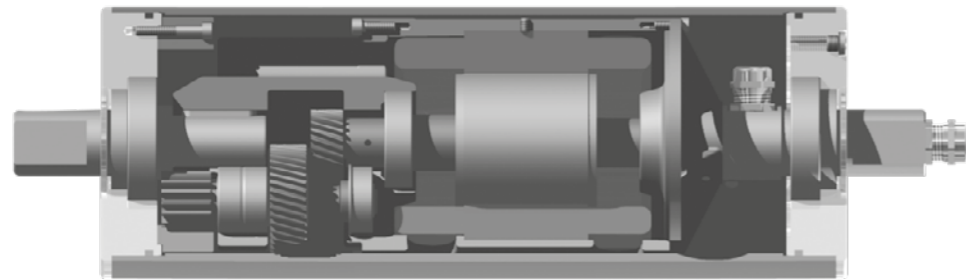

# MODEL SERIES TM138

## Execution types and options

Standard version	Optionen
<ul style="list-style-type: none"> <li>• Spherically turned steel jacket, bright steel, coated with rust protection</li> <li>• IP66</li> <li>• Aluminum bearing end caps</li> <li>• Clamping spigot made of steel, coated with rust protection</li> <li>• Spur gearbox with steel gearing (low-noise)</li> <li>• Straight screw connection (incl. 3 m cable)</li> </ul>	<ul style="list-style-type: none"> <li>• Internal brake</li> <li>• with terminal box</li> <li>• Elbow fitting (with 3 m cable)</li> <li>• Stainless steel elbow fitting (with 3 m cable)</li> <li>• Right-angled straight screw connection (with 3 m cable)</li> <li>• Backstop (ball bearing freewheel)</li> <li>• Sprocket/toothed belt pulley</li> <li>• Sensor bearing unit (rotary encoder)</li> <li>• Cylindrical drum body, rubberized, galvanized (customized)</li> <li>• Stainless steel version</li> <li>• Thermal contacts</li> <li>• IP67</li> <li>• IP69K</li> <li>• Suitable for frequency inverter operation</li> <li>• for plastic modular belts and profile rubberizing</li> <li>• Terminal box design in stainless steel</li> <li>• Vertical installation possible (specify when ordering)</li> <li>• Food oil</li> <li>• Single-phase AC motors on request</li> <li>• cCSAus</li> </ul>
	Other versions available on request.

## Clamping bearing for HIMMEL®-drum motor / HIMMEL® deflection drum type 138

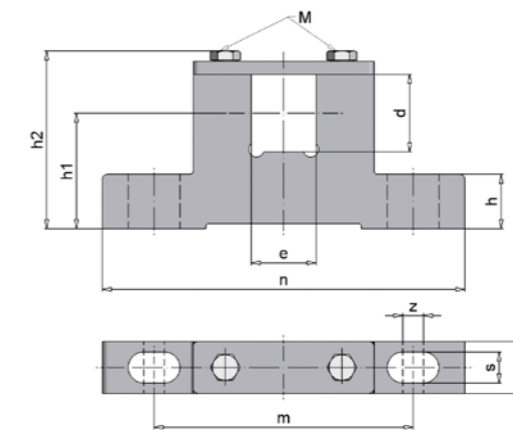

all dimensions in mm

Drum type	Clamping bearing	d	e	h	h1	h2	m	n	s	w	z	M	Material	approx. kg
TM138.1	EL30/20	30	20	21	44,5	68,5	100	140	12	24	8	M6	Steel	0,7

Color of the clamping bearings in RAL 7031



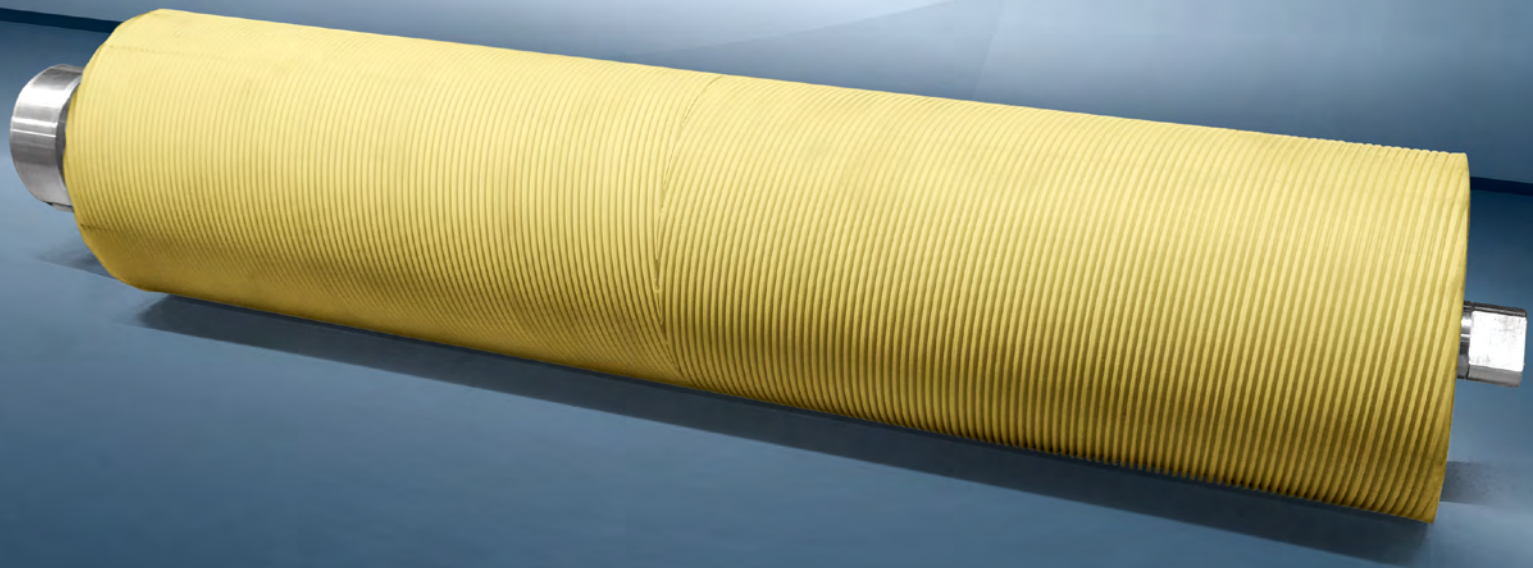

**| MODEL SERIES TM165**

# MODEL SERIES TM165

## Drum motor TM165, standard

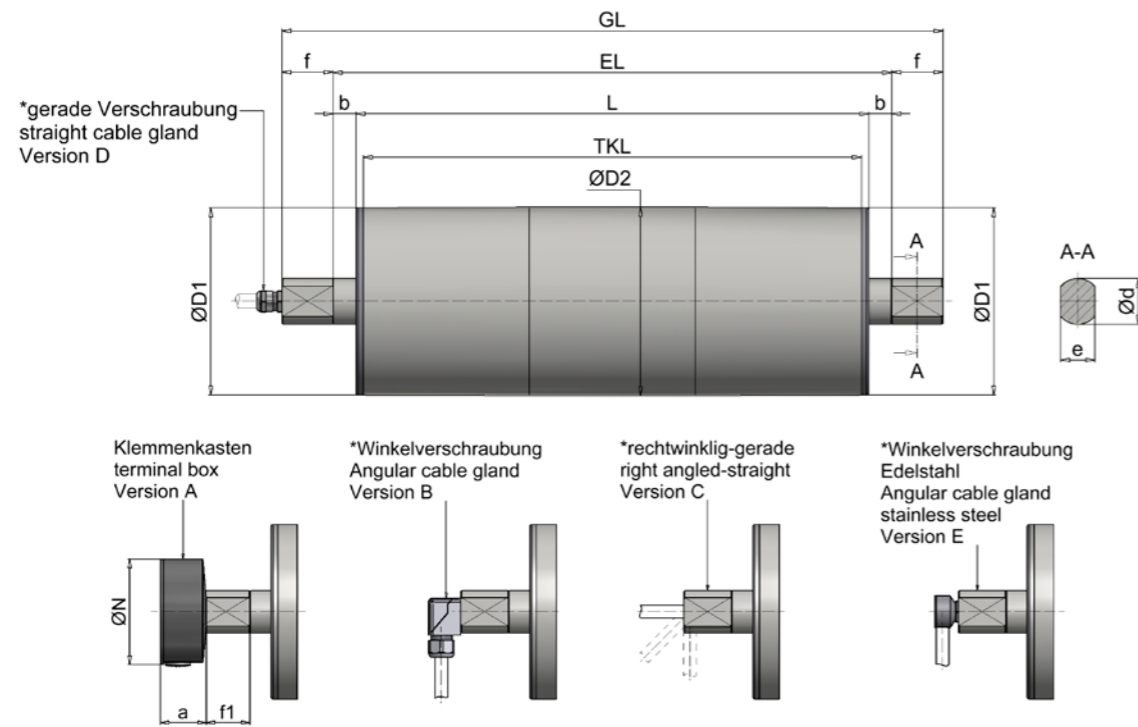

## Deflection drum UT165, standard

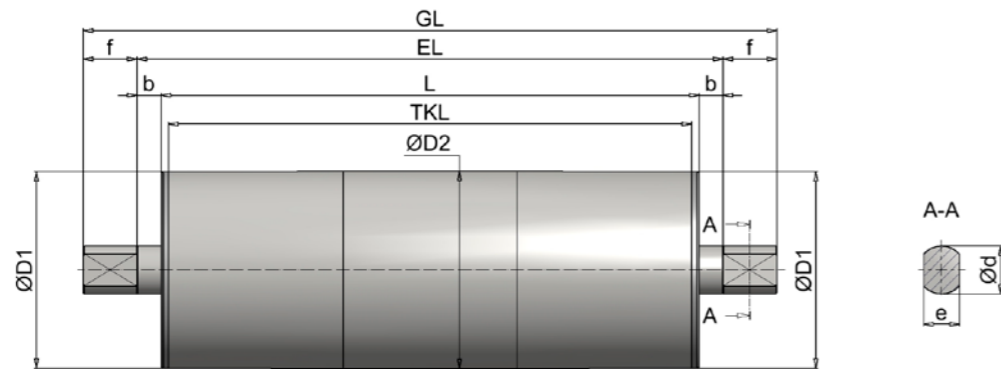

all dimensions in mm

HIMMEL® drum motor												
Size	Type	Ø D1	Ø D2**	a	Ø N	Ø d	e	f	f1	TKL	b	EL
165	TM165.1	164	165	43	100	40	30	45	43	L - 13	20	L + 40
HIMMEL® deflection drum												
165	UT165.1	164	165			40	30	45		L - 13	20	L + 40

\* with 3 m cable

\*\* Diameter with cylindrical drum body

# MODEL SERIES TM165

## Overview of services

Type	Performance	Speed	Rotational speed	Belt tension	Drum torque	Power consumption at 400 V / 50 Hz	Drum length L min.	Weight
	P2	v	n2	F	T2			
	[kW]	[m/s]	[1/min]	[N]	[Nm]	[A]	[mm]	[kg]
TM165.1	0,37 8-pole	0,19	22	1911	158	1,50	IP66 400 IP67 400 IP69K 450	44,0
		0,24	27	1573	130			
		0,28	33	1315	108			
		0,33	39	1111	92			
		0,39	45	946	78			
		0,46	53	810	67			
		0,54	63	682	56			
		0,66	76	562	46			
		0,79	91	470	39			
		0,93	108	397	33			
1,09	127	338	28					
1,28	148	289	24					
TM165.1	0,75 6-pole	0,25	29	2947	243	2,20	IP66 400 IP67 400 IP69K 450	44,0
		0,31	36	2427	200			
		0,37	43	2028	167			
		0,44	51	1714	141			
		0,51	59	1460	120			
		0,60	69	1249	103			
		0,71	82	1053	87			
		0,87	100	867	71			
		1,04	120	724	60			
		1,23	142	612	51			
1,44	167	521	43					
1,68	195	446	37					
TM165.1	1,10 4-pole	0,39	45	2841	234	3,00	IP66 400 IP67 400 IP69K 450	44,0
		0,47	54	2339	193			
		0,56	65	1955	161			
		0,67	77	1652	136			
		0,78	91	1407	116			
		0,91	106	1204	99			
		1,08	126	1014	84			
		1,32	152	835	69			
		1,58	182	698	58			
		1,86	216	590	49			
2,19	253	502	41					
2,56	296	430	35					
TM165.1	1,50 4-pole	0,56	65	2656	219	3,60	IP66 425 IP67 425 IP69K 475	47,0
		0,67	77	2245	185			
		0,78	91	1911	158			
		0,92	106	1636	135			
		1,09	126	1378	114			
		1,32	153	1135	94			
		1,58	183	949	78			
		1,87	217	802	66			
		2,20	254	683	56			
		2,57	297	584	48			

# MODEL SERIES TM165

## Overview of services

Type	Performance	Speed	Rotational speed	Belt tension	Drum torque	Power consumption at 400 V / 50 Hz	Drum length L min.	Weight	
	P2	v	n2	F	T2				L=500 mm
	[kW]	[m/s]	[1/min]	[N]	[Nm]				[A]
TM165.1	2,20 2-pole	0,78	91	2805	231	4,30	IP66 425 IP67 425 IP69K 475	47,0	
		0,95	110	2310	191				
		1,14	132	1931	159				
		1,35	156	1632	135				
		1,58	183	1389	115				
		1,85	214	1189	98				
		2,20	254	1002	83				
		2,67	309	825	68				
		3,19	369	690	57				
		3,78	437	583	48				
TM165.1	3,00 2-pole	1,10	127	2561	212	6,80	IP66 470 IP67 470 IP69K 500	48,0	
		1,30	151	2163	179				
		1,53	177	1843	152				
		1,79	207	1577	130				
		2,12	246	1357	112				
		2,58	300	1117	93				
		3,08	357	934	78				
		3,65	423	789	66				
		4,28	496	672	56				
		5,01	580	575	48				

- Deviating performance data and speeds on request
- Weight incl. oil filling (ready for operation)
- Additional weight: approx. 3 kg for 100 mm additional length
- With brake attachment, the L min. dimension increases by 110 mm

Standard widths [L] : 400, 425, 450, 500 ... 1300 mm from 1300 mm reinforced version.



Drum motors in mobile conveyor systems

# MODEL SERIES TM165

## Execution types and options

Standard version	Options
<ul style="list-style-type: none"> <li>• Spherically turned steel jacket, bright steel, coated with rust protection</li> <li>• IP66</li> <li>• Aluminum bearing end caps</li> <li>• Clamping spigot made of steel, coated with rust protection</li> <li>• Spur gearbox with steel gearing (low-noise)</li> <li>• Straight screw connection (incl. 3m cable)</li> </ul>	<ul style="list-style-type: none"> <li>• Internal brake</li> <li>• With terminal box</li> <li>• Elbow fitting (with 3 m cable)</li> <li>• Stainless steel elbow fitting (with 3 m cable)</li> <li>• Right-angled straight screw connection (with 3 m cable)</li> <li>• Backstop (ball bearing freewheel)</li> <li>• Sprocket/toothed belt pulley</li> <li>• Sensor bearing unit (rotary encoder)</li> <li>• Cylindrical drum body, rubberized, galvanized (customized)</li> <li>• Stainless steel version</li> <li>• Thermal contacts</li> <li>• IP67</li> <li>• IP69K</li> <li>• Suitable for frequency inverter operation</li> <li>• for plastic modular belts and profile rubberizing</li> <li>• Terminal box design in stainless steel</li> <li>• Vertical installation possible (specify when ordering)</li> <li>• Food oil</li> <li>• Single-phase AC motors on request</li> <li>• cCSAus</li> </ul>
	Other versions available on request.

## Clamping bearing for HIMMEL®-drum motor / HIMMEL® deflection drum type 165

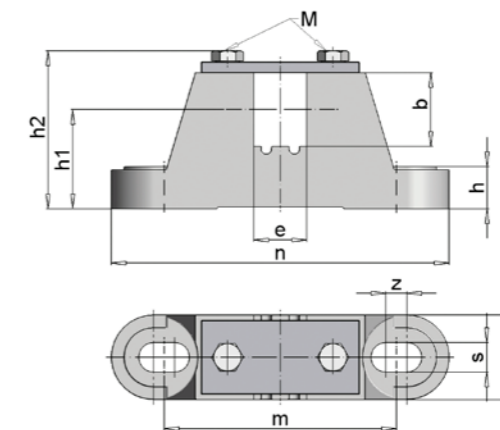

all dimensions in mm

Drum type	Clamping bearing	d	e	h	h1	h2	m	n	s	w	z	M	Material	approx. kg
TM/UT165.1	EL40/30 A	40	30	20	47	78,5	110	160	14	40	10	M8	Cast iron	1,5

Color of the clamping bearings in RAL 7031



**| MODEL SERIES TM216**

# MODEL SERIES TM216

## Drum motor TM216.0, standard



\*gerade Verschraubung  
straight cable gland  
Version D

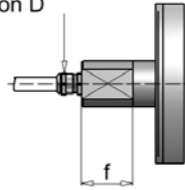

\*Winkelverschraubung  
Angular cable gland  
Version B

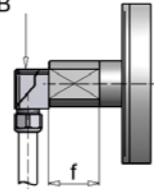

## Deflection drum UT165, standard

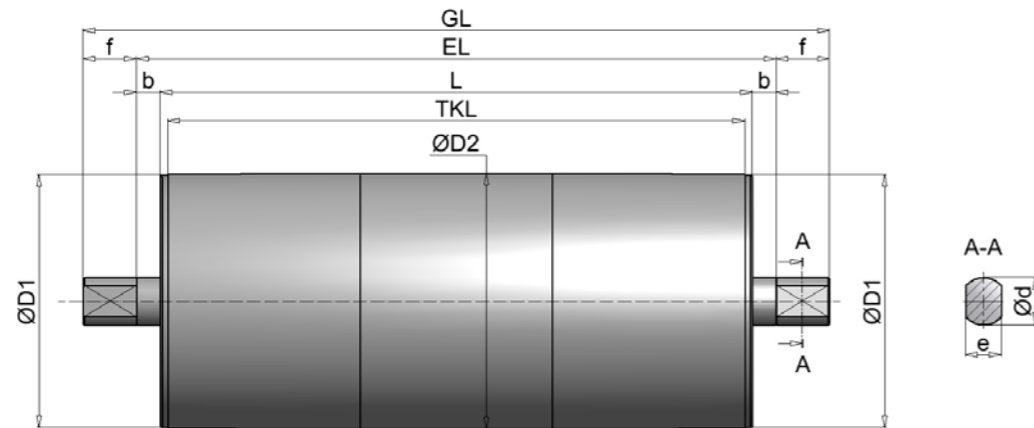

all dimensions in mm

HIMMEL® drum motor													
Size	Type	Ø D1	Ø D2**	a	Ø N	c	Ø d	e	f	f1	TKL	b	EL
216	TM216.0	213,5	216	43	100		40	30	45	45	L - 13	20	L + 40

HIMMEL® deflection drum													
Size	Type	Ø D1	Ø D2**	a	Ø N	c	Ø d	e	f	f1	TKL	b	EL
216	UT216.0	213,5	216				40	30	45		L - 13	20	L + 40

\* with 3 m cable

\*\* Diameter with cylindrical drum body

# MODEL SERIES TM216

## Drum motor TM216.1, standard

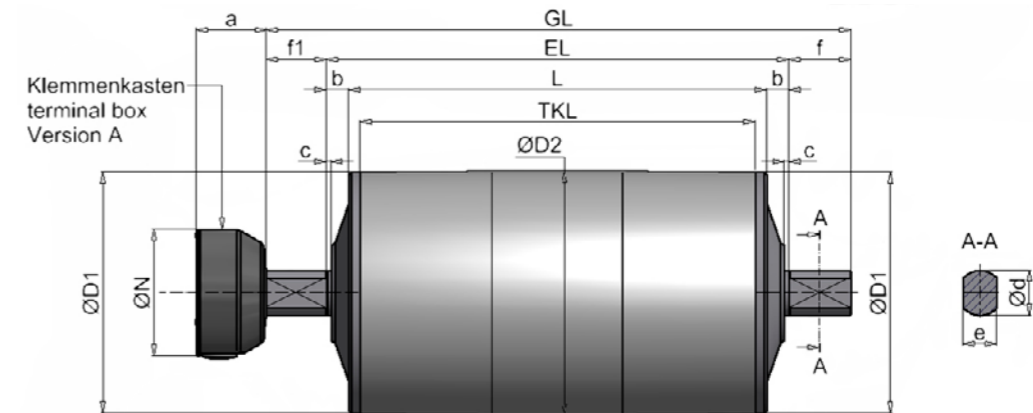

\*gerade Verschraubung  
straight cable gland  
Version D

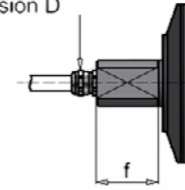

\*Winkelverschraubung  
Angular cable gland  
Version B

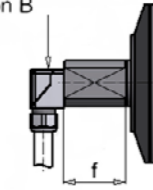

## Deflection drum UT216.1, standard

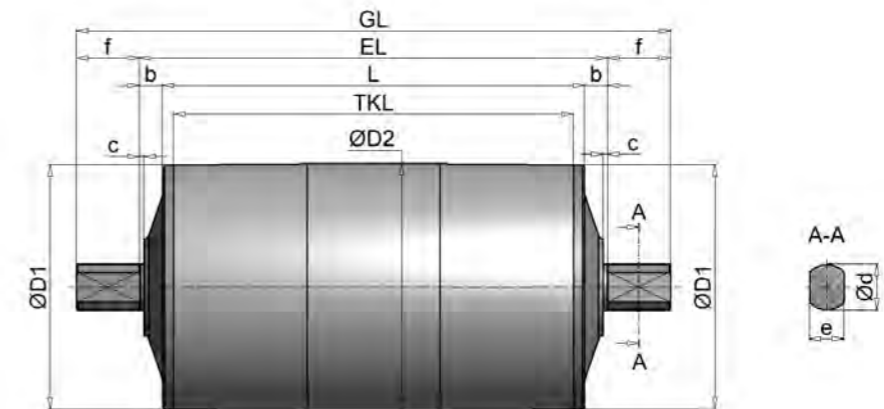

all dimensions in mm

HIMMEL® drum motor												Standard IP65		optional IP66		optional IP67	
Size	Type	Ø D1	Ø D2**	a	Ø N	c	Ø d	e	f	f1	TKL	b	EL	b	EL	b	EL
216	TM216.1	213,5	216	62	112	4	40	30	55	53	L - 20	20	L + 40	20	L + 40	37	L + 74

HIMMEL® deflection drum																		
Size	Type	Ø D1	Ø D2**	a	Ø N	c	Ø d	e	f	f1	TKL	b	EL	b	EL	b	EL	
216	UT216.1	213,5	216				4	40	30	55		L - 20	20	L + 40	20	L + 40	37	L + 74

\* with 3 m cable

\*\* Diameter with cylindrical drum body

# MODEL SERIES TM216

## Overview of services type TM216.0-TM216.1

Type	Performance	Speed	Rotational speed	Belt tension	Drum torque	Power consumption at 400 V / 50 Hz	Drum length L min.	Weight				
	P2	v	n2	F	T2			L=500 mm				
	[kW]	[m/s]	[1/min]	[N]	[Nm]			[A]	[mm]	[kg]		
TM216.0	0,37 8-pole	0,25	22	1460	158	1,50	400	50				
		0,31	27	1202	130							
		0,37	33	1005	108							
		0,44	39	849	92							
		0,51	45	723	78							
		0,60	53	619	67							
		0,71	63	521	56							
		0,86	76	429	46							
		1,03	91	359	39							
		1,22	108	303	33							
TM216.0	0,75 6-pole	0,33	29	2251	243	2,20	400	50				
		0,40	36	1854	200							
		0,48	43	1549	167							
		0,57	51	1309	141							
		0,67	59	1115	120							
		0,79	69	954	103							
		0,93	82	804	87							
		1,13	100	662	71							
		1,36	120	553	60							
		1,60	142	468	51							
TM216.1	1,50 4-pole	0,33	29	4604	497	3,20	420	57,0				
		0,37	33	4016	434							
		0,48	42	3134	338							
		0,60	53	2504	270							
		TM216.1	2,20 4-pole	0,47	42			4679	505	4,80	420	59,0
				0,59	52			3738	404			
				0,84	75			2610	282			
				1,15	102			1909	206			
TM216.1	3,00 4-pole	0,85	75	3547	383	6,60	450	57,0				
		1,16	102	2594	280							
		1,33	117	2263	244							
		1,70	150	1766	191							
		2,13	188	1411	152							

- Deviating performance data and speeds on request
- Weight incl. oil filling (ready for operation)
- Additional weight: approx. 5 kg per 100 mm additional length
- With brake attachment, the L min. dimension increases by 110 mm

Standard widths [L] : 400, 425, 450, 500 ... 1350 mm from 1350 mm reinforced version.

# MODEL SERIES TM216

## Execution types and options

Standard version	Options
<ul style="list-style-type: none"> <li>• Spherically turned steel jacket, bright steel, coated with rust protection</li> <li>• IP66 with TM216.0</li> <li>• IP65 with TM216.1</li> <li>• 216.0 – Aluminum bearing end caps</li> <li>• 216.1 – Bearing end cover made of gray cast iron, painted to RAL 7031</li> <li>• Clamping spigot made of steel, coated with rust protection</li> <li>• Spur gearbox with steel gearing (low-noise)</li> <li>• Terminal box</li> </ul>	<ul style="list-style-type: none"> <li>• Internal brake</li> <li>• Elbow fitting (with 3 m cable)</li> <li>• Straight screw connection (incl. 3 m cable)</li> <li>• Backstop (ball bearing freewheel)</li> <li>• Sprocket/toothed belt pulley</li> <li>• Sensor bearing unit (rotary encoder)</li> <li>• Cylindrical drum body, rubberized, galvanized</li> <li>• (customized)</li> <li>• Stainless steel version</li> <li>• Thermal contacts</li> <li>• IP66</li> <li>• IP67</li> <li>• Suitable for frequency inverter operation</li> <li>• Terminal box design in stainless steel</li> <li>• Vertical installation possible (specify when ordering)</li> <li>• Food oil</li> </ul> <p>Other versions available on request.</p>

## Clamping bearing for HIMMEL®-drum motor / HIMMEL® deflection drum type 216

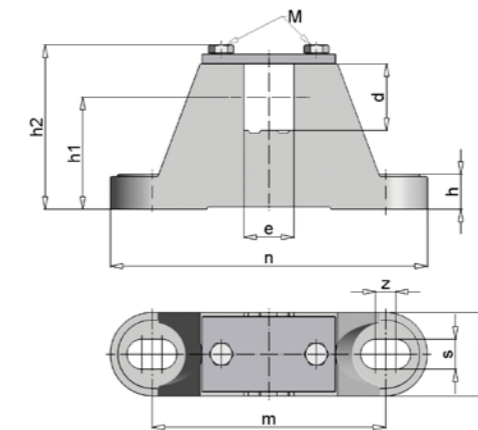

all dimensions in mm

Drum type	Clamping bearing	d	e	h	h1	h2	m	n	s	w	z	M	Material	approx. kg
TM/UT216.0	EL40/30 A	40	30	20	47	76	110	160	14	40	10	M8	Cast iron	1,5
TM/UT216.1	EL40/30 B	40	30	21	67	102,5	140	190	18	50	12	M8		2,8

Color of the clamping bearings in RAL 7031

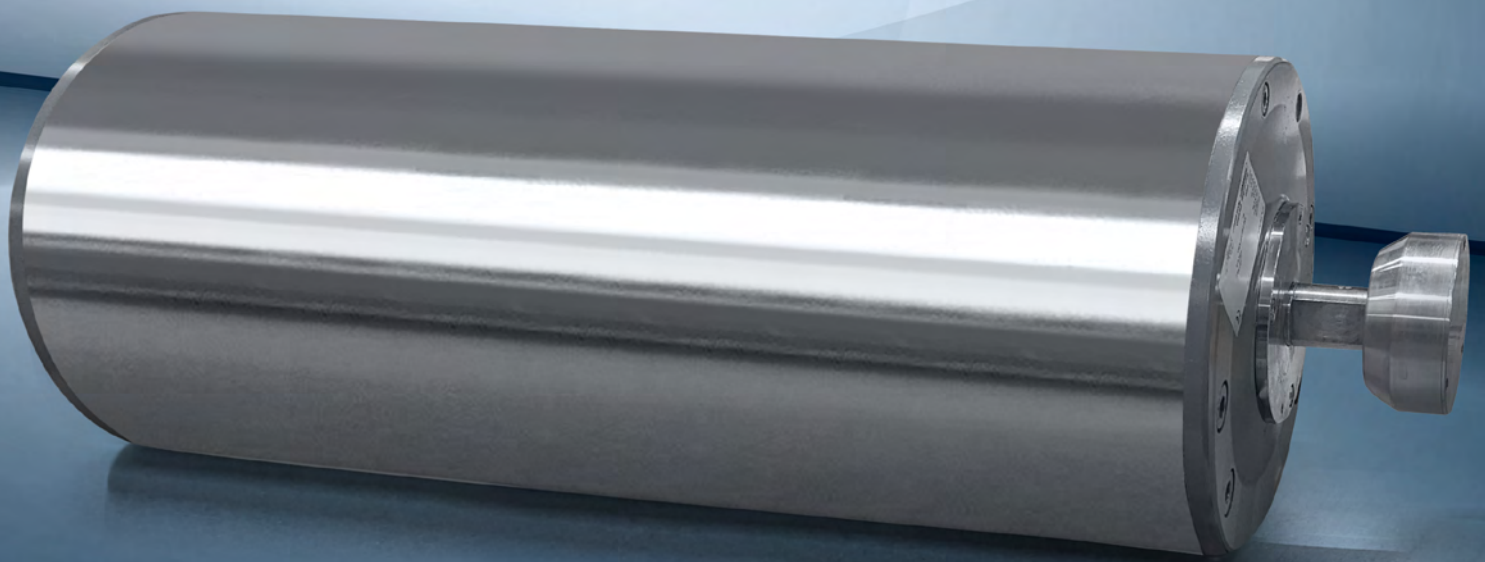

**| MODEL SERIES TM321**

# MODEL SERIES TM321

## Drum motor TM321, standard

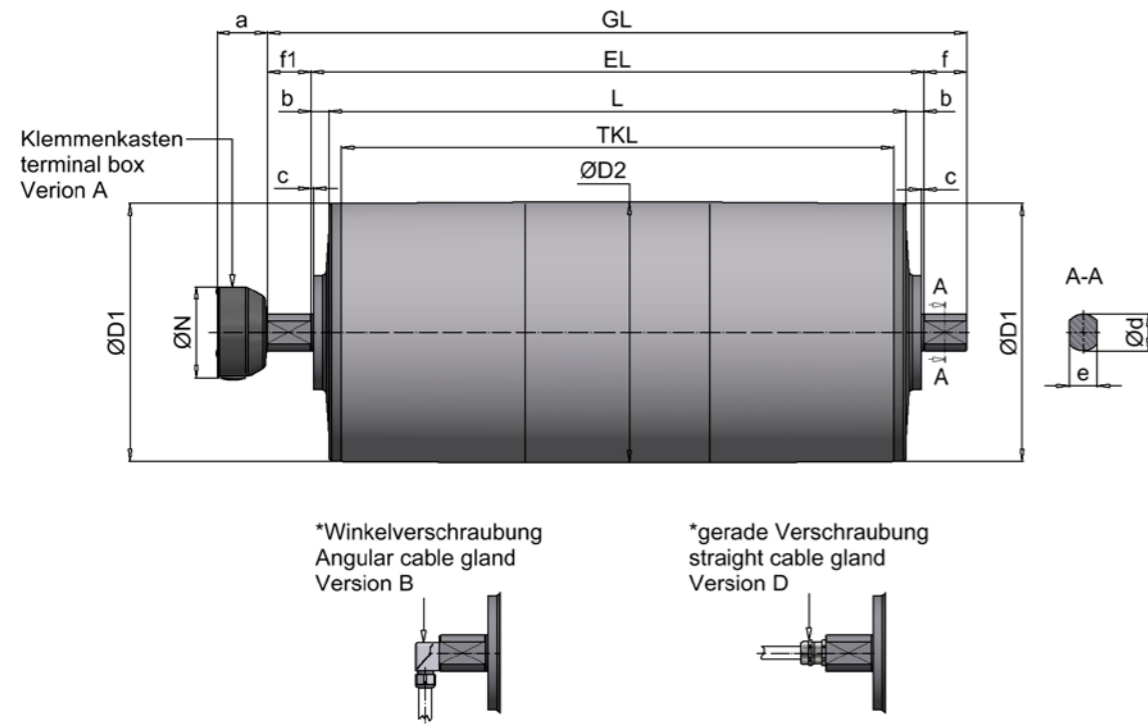

## deflection drum UT321, standard

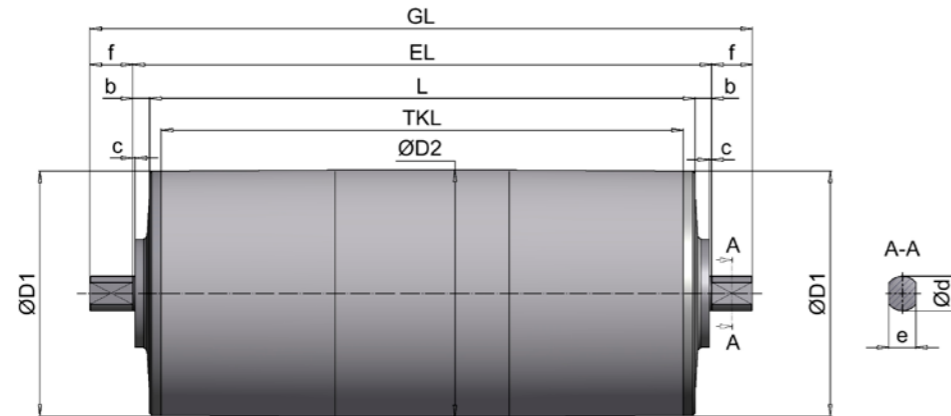

all dimensions in mm

HIMMEL® drum motor												Standard IP66		optional IP67	
Size	Type	Ø D1	Ø D2**	a	Ø N	c	Ø d	e	f	f1	TKL	b	EL	b	EL
321	TM321.0	318	321	62	112	3	40	30	55	53	L - 30	20	L + 40	45	L + 90
321	TM321.1	318	321			3	45	35	53	51	L - 30	22	L + 44	45	L + 90
HIMMEL® deflection drum															
321	UT321.0	318	321			3	40	30	55		L - 30	20	L + 40	45	L + 90
321	UT321.1	318	321			3	45	35	53		L - 30	22	L + 44	45	L + 90

\* with 3 m cable

\*\* Diameter with cylindrical drum body

# MODEL SERIES TM321

## Overview of services type TM321.0-TM321.1

Type	Performance	Speed	Rotational speed	Belt tension	Drum torque	Power consumption at 400 V / 50 Hz	Drum length L min.	Weight
	P2	v	n2	F	T2			
	[kW]	[m/s]	[1/min]	[N]	[Nm]			[A]
TM321.0	1,50 4-pole	0,48	29	3098	497	3,20	520	95
		0,56	33	2702	434			
		0,71	42	2109	338			
		0,89	53	1685	270			
		1,11	66	1356	218			
		1,27	76	1177	189			
		1,74	104	861	138			
		2,00	119	751	120			
2,34	139	641	103					
TM321.1	2,20 4-pole	0,39	23	5622	902	4,80	550	120
0,48		28	4593	737				
0,70		42	3148	505				
0,87		52	2516	404				
1,09		65	2025	325				
1,25		75	1756	282				
1,71		102	1285	206				
1,96		117	1121	180				
2,30	137	957	154					
TM321.1	3,00 4-pole	0,60	36	4986	800	6,60	550	125
0,74		44	4070	653				
0,84		50	3564	572				
1,09		65	2751	442				
1,26		75	2387	383				
1,72		102	1746	280				
1,97		117	1523	244				
TM321.1	4,00 4-pole	0,73	44	5465	877	9,00	550	130
1,08		64	3694	593				
1,33		79	3019	484				
1,66		99	2411	387				
2,03		121	1968	316				
TM321.1	5,50 4-pole	1,04	62	5282	848	11,50	680	140
1,28		76	4312	692				
1,65		98	3324	533				
2,04		121	2697	433				
2,68		159	2054	330				
3,28	195	1677	269					
TM321.1	7,50 4-pole	1,65	98	4532	727	15,50	680	150
2,04		121	3678	590				
2,68		159	2801	450				
3,28		195	2287	367				

- Deviating performance data and speeds on request
- Weight incl. oil filling (ready for operation)
- Additional weight: approx. 6 kg for 100 mm additional length
- The L min. dimension increases by 130 mm when the brakes are fitted

Standard widths [L] : 520, 550, 600, 680 ... 1600 mm from 1600 mm reinforced version.



# MODEL SERIES TM321

## Execution types and options

Standardausführung	Optionen
<ul style="list-style-type: none"> <li>Spherically turned steel jacket, bright steel, coated with rust protection</li> <li>IP66</li> <li>Bearing end cover made of gray cast iron, painted to RAL 7031</li> <li>Clamping spigot made of steel, coated with rust protection</li> <li>Spur gearbox with steel gearing (low-noise)</li> <li>Terminal box</li> </ul>	<ul style="list-style-type: none"> <li>Internal brake</li> <li>Elbow fitting (with 3 m cable)</li> <li>Straight screw connection (incl. 3 m cable)</li> <li>Backstop (ball bearing freewheel)</li> <li>Sprocket/toothed belt pulley</li> <li>Cylindrical drum body, rubberized, galvanized</li> <li>(customized)</li> <li>Stainless steel version</li> <li>Thermal contacts</li> <li>IP67</li> <li>Suitable for frequency inverter operation</li> <li>Terminal box design in stainless steel</li> <li>Vertical installation possible (specify when ordering)</li> <li>Food oil</li> </ul> <p>Other versions available on request.</p>

## Clamping bearing for HIMMEL® drum motor / HIMMEL® deflection drum type 321

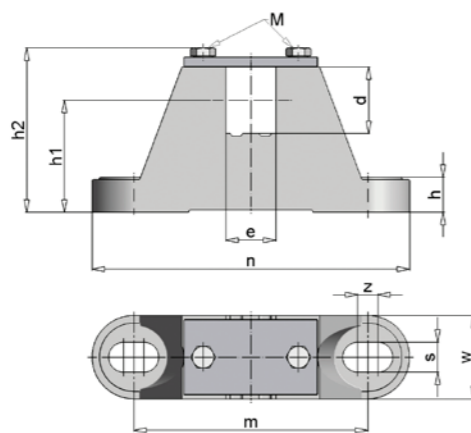

all dimensions in mm

Drum type	Clamping bearing	d	e	h	h1	h2	m	n	s	w	z	M	Material	approx. kg
TM/UT321.0	EL40/30 B	40	30	21	67	102,5	140	190	18	50	12	M8	Cast iron	2,8
TM/UT321.1	EL45/35	45	35	21	67	105	140	190	18	50	12	M8		2,8

Color of the clamping bearings in RAL 7031

# MODEL SERIES TM321



Drum motors in a screening machine



Drum motors in a screening machine

## MODEL SERIES TM415

### Drum motor TM415, default

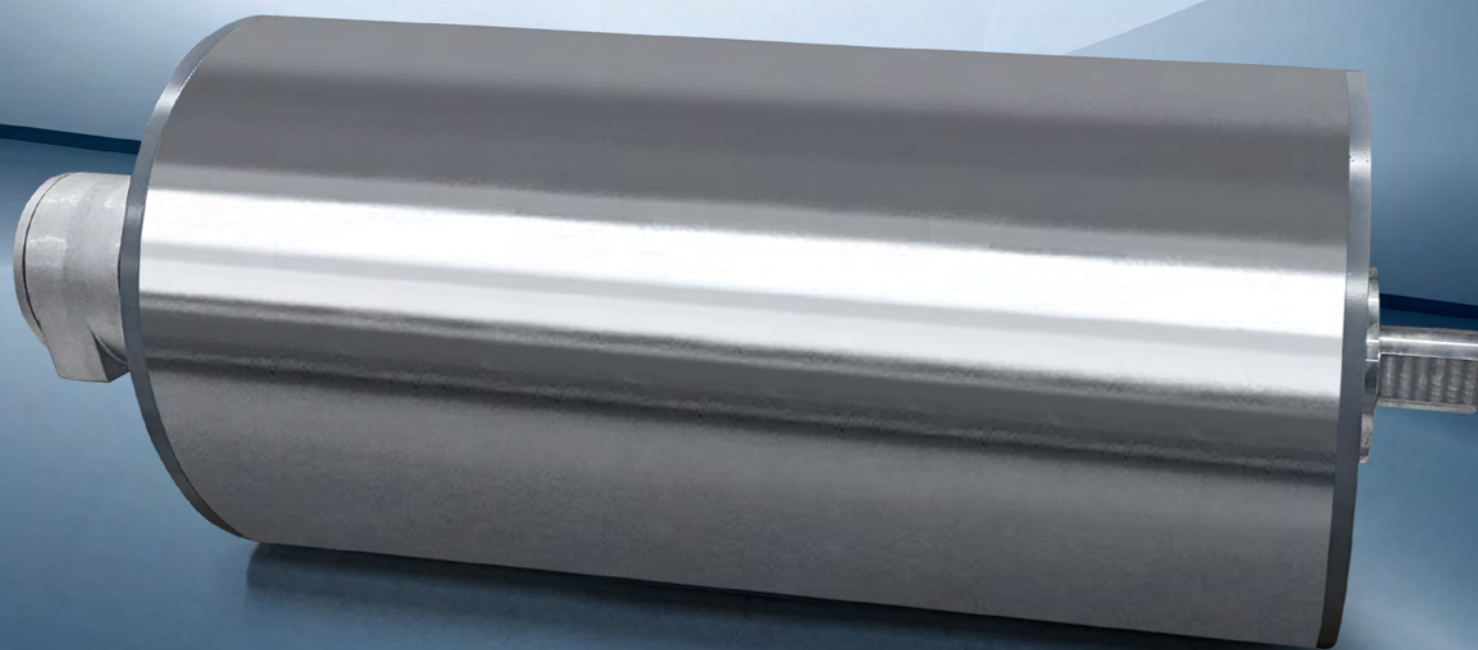
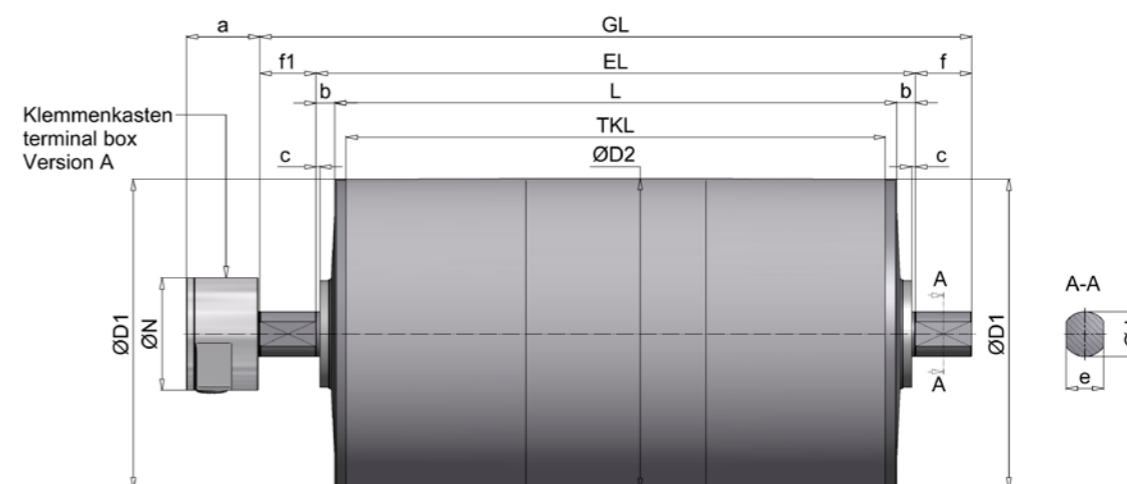

### deflection drum UT415, standard



all dimensions in mm

HIMMEL <sup>®</sup> drum motor												Standard IP66		optional IP67	
Size	Type	Ø D1	Ø D2*	a	Ø N	c	Ød	e	f	f1	TKL	b	EL	b	EL
415	TM415.0	413	415	62	112	3	45	35	53	51	L - 30	22	L + 44	32	L + 64
415	TM415.1	413	415	100	150	5	60	50	75	75	L - 30	25	L + 50	35	L + 70
HIMMEL <sup>®</sup> deflection drum															
415	UT415.0	413	415			3	45	35	53		L - 30	22	L + 44	32	L + 64
415	UT415.1	413	415			5	60	50	75		L - 30	25	L + 50	35	L + 70

\* Diameter with cylindrical drum body

# MODEL SERIES TM415

## Overview of services type TM415.0-TM415.1

Type	Performance	Speed	Rotational speed	Belt tension	Drum torque	Power consumption at 400 V / 50 Hz	Drum length L min.	Weight
	P2	v	n2	F	T2			L=750 mm
	[kW]	[m/s]	[1/min]	[N]	[Nm]			[kg]
TM415.0	3,00 4-pole	0,78	36	3857	800	3,20	550	160
		0,95	44	3148	653			
		1,32	61	2276	472			
		1,61	74	1858	386			
TM415.1	4,00 4-pole	0,60	28	6678	1386	9,00	750	275
0,84		39	4746	985	550		170	
0,95		44	4227	877				
1,31		60	3056	634				
1,60		74	2495	518				
2,08		96	1923	399				
TM415.1	5,50 4-pole	0,87	40	6344	1316	11,50	750	290
		1,04	48	5267	1093			
		1,29	59	4266	885			
		1,56	72	3530	733			
		1,72	79	3201	664			
		2,17	100	2534	526			
TM415.1	7,50 4-pole	1,04	48	7182	1490	15,50	750	300
		1,29	59	5818	1207			
		1,56	72	4814	999			
		1,72	79	4365	906			
		2,17	100	3456	717			
TM415.1	10,00 4-pole	1,28	59	7811	1621	21,00	750	320
		1,55	71	6464	1341			
		1,71	79	5861	1216			
		2,16	99	4640	963			
TM415.1	15,00 4-pole	1,71	79	8792	1824	29,50	750	360
		2,16	99	6959	1444			

- Deviating performance data and speeds on request
- Weight incl. oil filling (ready for operation)
- Additional weight: approx. 10 kg per 100 mm additional length
- The L min. dimension increases by 200 mm for brake attachment

Standard widths [L] : 550, 600, 650 ... 1400 mm from 1400 mm reinforced version.

# MODEL SERIES TM415

## Execution types and options

Standard version
<ul style="list-style-type: none"> <li>• Spherically turned steel jacket, bright steel, coated with rust protection</li> <li>• IP66</li> <li>• Bearing end cover made of gray cast iron, painted to RAL 7031</li> <li>• Clamping spigot made of steel, coated with rust protection</li> <li>• Spur gearbox with steel gearing (low-noise)</li> <li>• Terminal box</li> </ul>

Options
<ul style="list-style-type: none"> <li>• Internal brake</li> <li>• Backstop (ball bearing freewheel)</li> <li>• Sprocket/toothed belt pulley</li> <li>• Cylindrical drum body, rubberized, galvanized (customized)</li> <li>• Stainless steel version</li> <li>• Thermal contacts</li> <li>• IP67</li> <li>• Suitable for frequency inverter operation</li> <li>• Terminal box design in stainless steel</li> <li>• Vertical installation possible (specify when ordering)</li> <li>• Food oil</li> </ul> <p>Other versions available on request.</p>

## Clamping bearing for HIMMEL®-drum motor / HIMMEL® deflection drum type 415

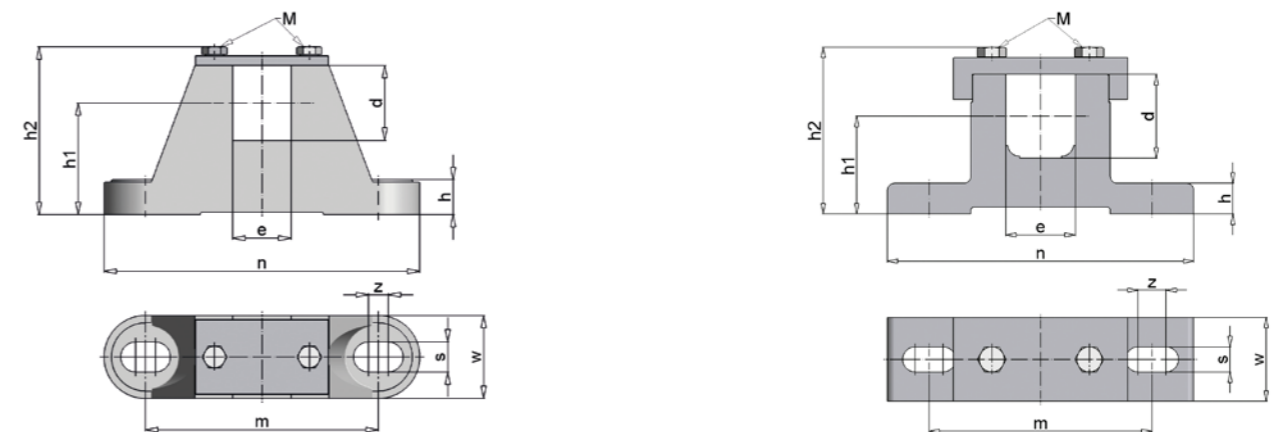

all dimensions in mm

Drum type	Clamping bearing	d	e	h	h1	h2	m	n	s	w	z	M	Material	approx. kg
TM/UT415.0	EL45/35	45	35	21	67	105	140	190	18	50	12	M8	Cast iron	2,8
TM/UT415.1	EL60/50	60	50	22	70	119,5	160	220	18	60	20	M12	Steel	5

Color of the clamping bearings in RAL 7031

## MODEL SERIES TM518

### Drum motor TM518, standard

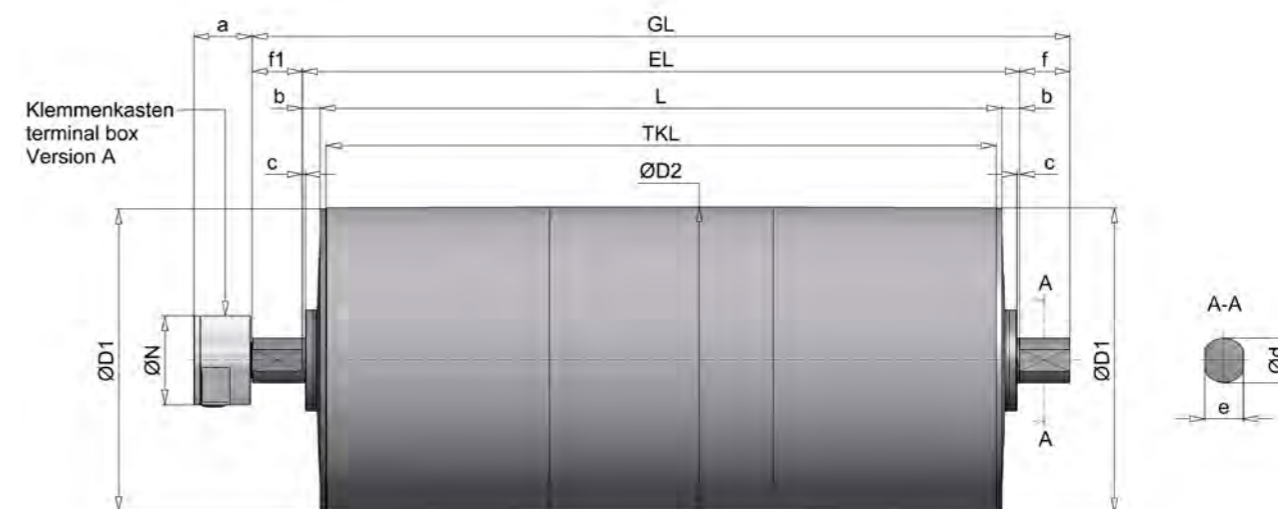

### deflection drum UT518, standard

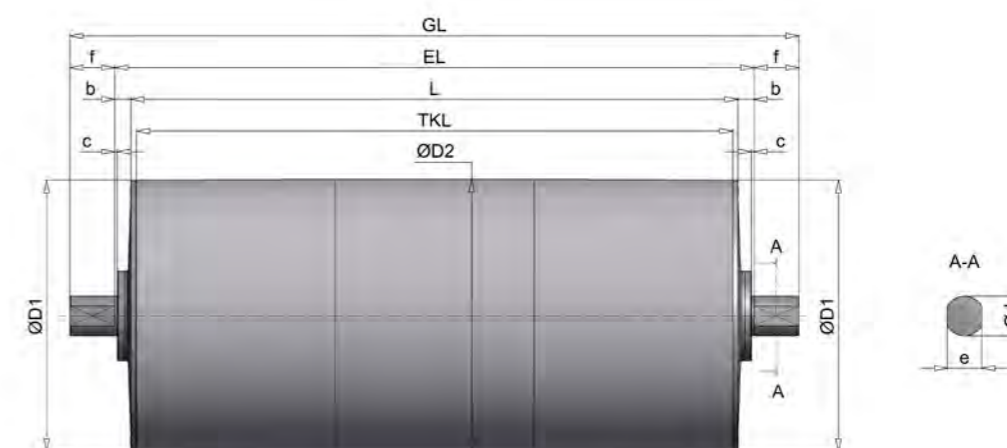

all dimensions in mm

HIMMEL <sup>®</sup> drum motor												optional IP65	Standard IP66	optional IP67			
Size	Type	Ø D1	Ø D2*	a	Ø N	c	Ø d	e	f	f1	TKL	b	EL	b	EL	b	EL
518	TM518.0	515	518	100	150	5	60	50	75	75	L - 20			25	L + 50	35	L + 70
518	TM518.1	515	518			5	75	65	85	85	L - 20	30	L + 60	45	L + 90	60	L + 120

HIMMEL <sup>®</sup> deflection drum																	
Size	Type	Ø D1	Ø D2*	a	Ø N	c	Ø d	e	f	f1	TKL	b	EL	b	EL	b	EL
518	UT518.0	515	518			5	60	50	75		L - 20			25	L + 50	35	L + 70
518	UT518.1	515	518			5	75	65	85		L - 20	30	L + 60	45	L + 90	60	L + 120

\* Diameter with cylindrical drum body

# MODEL SERIES TM518

## Overview of services type TM518.0-TM518.1

Type	Performance	Speed	Rotational speed	Belt tension	Drum torque	Power consumption at 400 V / 50 Hz	Drum length L min.	Weight
	P2	v	n2	F	T2			L=950 mm
	[kW]	[m/s]	[1/min]	[N]	[Nm]			[kg]
TM518.1	4,00 4-pole	0,51 0,63	19 23	7813 6396	2024 1657	9,00	750	350
TM518.1	5,50 4-pole	0,53	19	10445	2705			
TM518.0		0,64	24	8551	2215			
		0,84	31	6545	1695			
		1,08	40	5083	1316			
		1,30	48	4219	1093			
1,61	59	3418	885					
TM518.1	7,50 4-pole	0,64	24	11660	3020	15,50	820	375
TM518.0		0,84	31	8924	2311			
		1,07	39	7012	1816			
		1,31	48	5740	1487			
		1,55	57	4845	1255			
		1,61	59	4661	1207			
		1,94	72	3857	999			
2,14	79	3497	906					
TM518.1	10,00 4-pole	0,83	31	11982	3103	21,00	820	462
TM518.0		1,06	39	9415	2438			
		1,30	48	7707	1996			
		1,54	57	6506	1685			
		1,7	63	5899	1528			
		2,08	77	4817	1248			
TM518.1	15,00 4-pole	1,31	48	11480	2973	29,50	800	448
TM518.0		1,55	57	9691	2510			
		1,71	63	8787	2276			
		2,09	77	7176	1859			
TM518.1	18,50 4-pole	1,59	58	11668	3022	37,00	850	470
TM518.0		1,75	64	10580	2740			
		2,14	79	8640	2238			
TM518.1	22,00 4-pole	1,75	64	12582	3259	43,50	850	470
TM518.0		2,14	79	10275	2661			

- Deviating performance data and speeds on request
- Weight incl. oil filling (ready for operation)
- Additional weight: approx. 10 kg per 100 mm additional length
- The L min. dimension increases by 200 mm for brake attachment

Standard widths [L] : 750, 800, 820, 850 ... 1600 mm from 1600 mm reinforced version.

# MODEL SERIES TM518

## Execution types and options

Standard version	Options
<ul style="list-style-type: none"> <li>• Spherically turned steel jacket, bright steel, coated with rust protection</li> <li>• IP66</li> <li>• Bearing end cover made of gray cast iron, painted to RAL 7031</li> <li>• Clamping spigot made of steel, coated with rust protection</li> <li>• Spur gearbox with steel gearing (low-noise)</li> <li>• Terminal box</li> </ul>	<ul style="list-style-type: none"> <li>• Internal brake</li> <li>• Backstop (ball bearing freewheel)</li> <li>• Sprocket/toothed belt pulley</li> <li>• Cylindrical drum body, rubberized, galvanized (customized)</li> <li>• Stainless steel version</li> <li>• Thermal contacts</li> <li>• IP65 with (TM/UT518.1)</li> <li>• IP67</li> <li>• Suitable for frequency inverter operation</li> <li>• Terminal box design in stainless steel</li> <li>• Vertical installation possible (specify when ordering)</li> <li>• Food oil</li> </ul> <p>Other versions available on request.</p>

## Clamping bearing for HIMMEL® drum motor / HIMMEL® deflection drum type 518

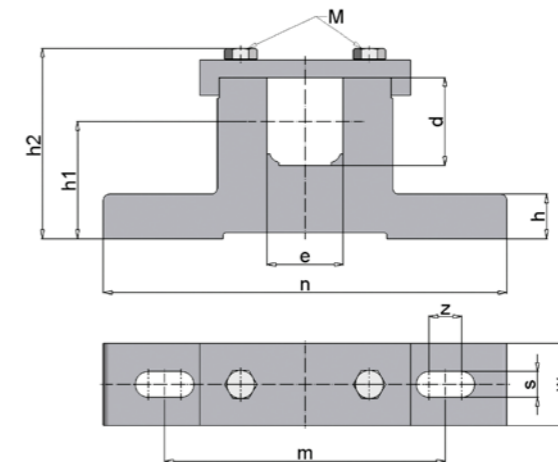

all dimensions in mm

Drum type	Clamping bearing	d	e	h	h1	h2	m	n	s	w	z	M	Material	approx. kg
TM/UT518.0	EL60/50	60	50	22	70	119,5	160	2220	18	60	20	M12	Cast iron	5
TM/UT518.1	EL75/65	75	65	38	100	162,5	240	345	22	70	28	M16	Steel	13,5

Color of the clamping bearings in RAL 7031

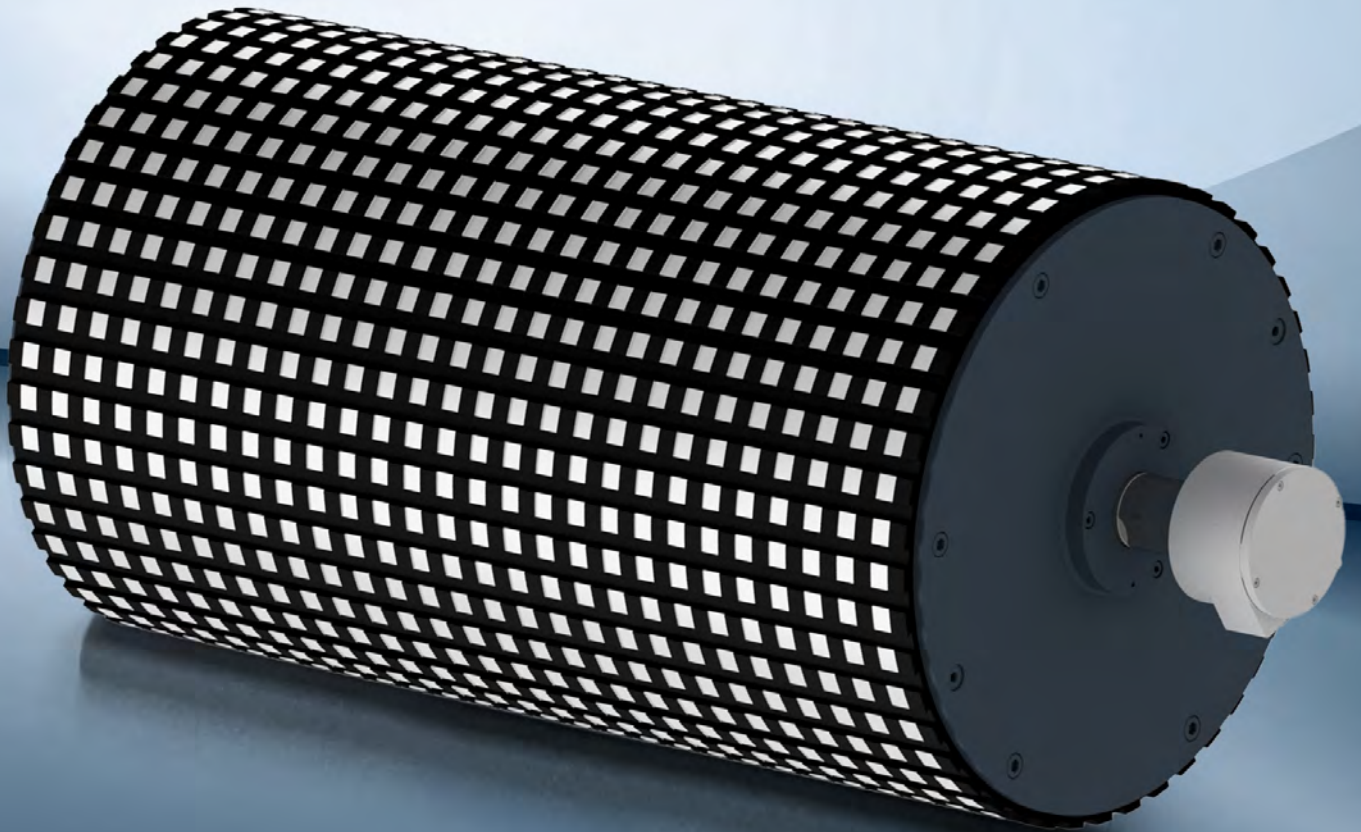

**| MODEL SERIES TM620**

## MODEL SERIES TM620

### Drum motor TM620, standard

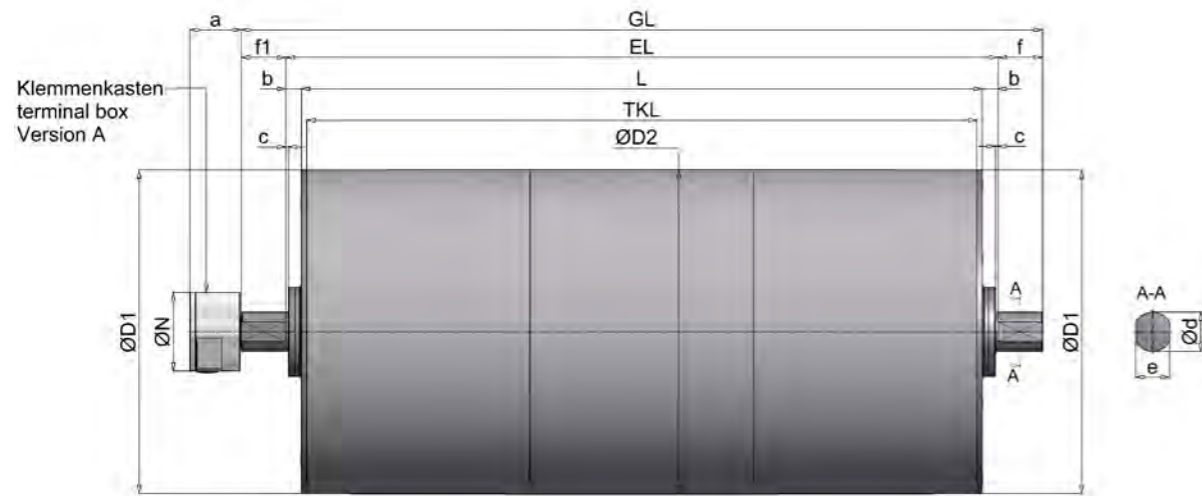

### deflection drum UT620, standard

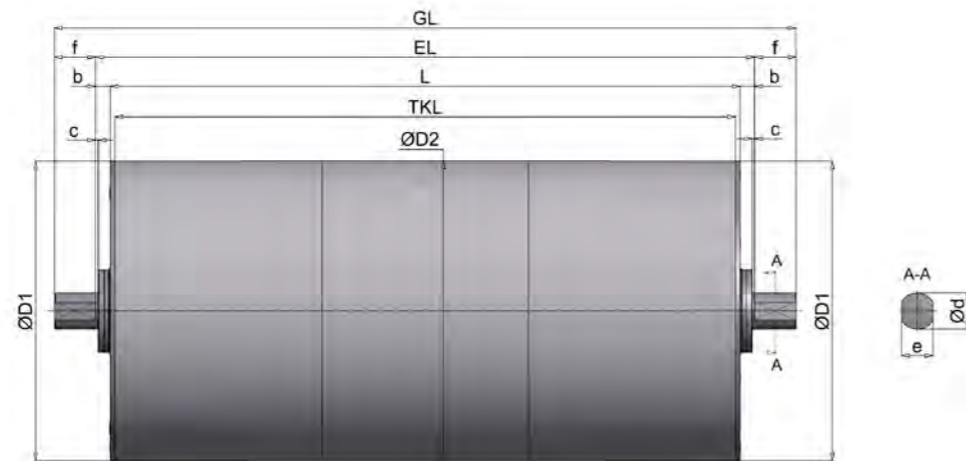

all dimensions in mm

HIMMEL® drum motor												Standard IP65		optional IP66		optional IP67	
Size	Type	Ø D1	Ø D2*	a	Ø N	c	Ø d	e	f	f1	TKL	b	EL	b	EL	b	EL
620	TM620.0	618	620	100	150	5	75	65	85	85	L - 20	30	L + 60	45	L + 90	60	L + 120
HIMMEL® deflection drum																	
620	UT620.0	618	820			5	75	65	85		L - 20	30	L + 60	45	L + 90	60	L + 120

\* Diameter with cylindrical drum body

## MODEL SERIES TM620

### Overview of services type TM620.0

Type	Performance	Speed	Rotational speed	Belt tension	Drum torque	Power consumption at 400 V / 50 Hz	Drum length L min.	Weight
	[kW]	[m/s]	[1/min]	[N]	[Nm]			[A]
TM620.0	7,50 4-pole	0,77	24	9742	3020	15,50	820	520
		1,01	31	7456	2311			
		1,28	39	5858	1816			
TM620.0	10,00 4-pole	1,00	31	10011	3103	21,00	820	530
		1,27	39	7866	2438			
		1,55	48	6439	1996			
		1,84	57	5435	1685			
		2,03	63	4929	1528			
TM620.0	15,00 4-pole	1,56	48	9592	2973	29,50	820	555
		1,85	57	8097	2510			
		2,04	63	7342	2276			
		2,50	77	5995	1859			
TM620.0	18,50 4-pole	1,90	58	9749	3022	37,00	850	595
		2,09	64	8840	2740			
		2,56	79	7219	2238			
TM620.0	22,00 4-pole	2,09	64	10512	3259	43,50	850	600
		2,56	79	8584	2661			

- Deviating performance data and speeds on request
- Weight incl. oil filling (ready for operation)
- Additional weight: approx. 25 kg for 100 mm additional length
- The L min. dimension increases by 200 mm for brake attachment

Standard widths [L] : 820, 850, 900 ... 1700 mm from 1700 mm reinforced version.

# MODEL SERIES TM620

## Execution types and options

Standard version
<ul style="list-style-type: none"> <li>Spherically turned steel casing, bright steel, coated with rust protection</li> <li>IP65</li> <li>Bearing end cover made of gray cast iron, painted to RAL 7031</li> <li>Clamping spigot made of steel, coated with rust protection</li> <li>Spur gear with steel gearing (low-noise)</li> <li>Terminal box</li> </ul>

Options
<ul style="list-style-type: none"> <li>Internal brake</li> <li>Backstop (ball bearing freewheel)</li> <li>Sprocket/toothed belt pulley</li> <li>Drum body cylindrical, rubberized, galvanized (customized)</li> <li>Stainless steel design</li> <li>Thermal contacts</li> <li>IP66</li> <li>IP67</li> <li>Suitable for frequency converter operation</li> <li>Terminal box design in stainless steel</li> <li>Vertical installation possible (specify when ordering)</li> <li>Food grade oil</li> </ul>
Other versions available on request.

# MODEL SERIES TM620

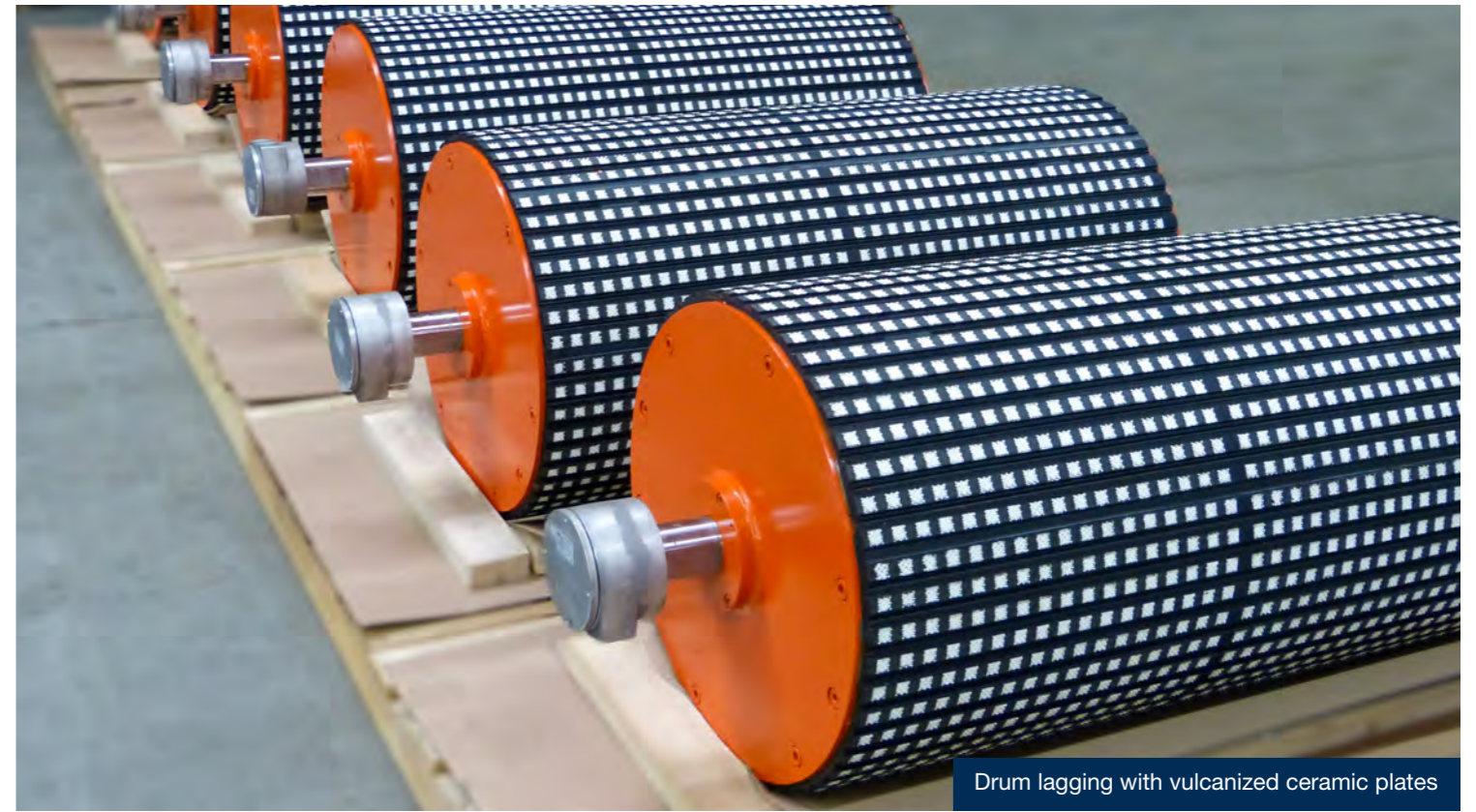

Drum lagging with vulcanized ceramic plates

## Clamping bearing for HIMMEL®-drum motor / HIMMEL® deflection drum type 620

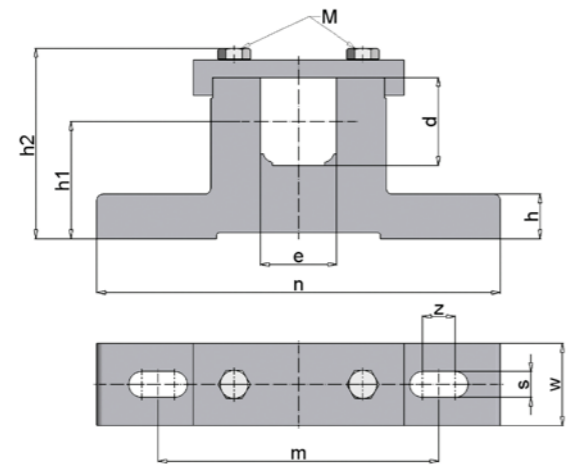

all dimensions in mm

Drum type	Clamping bearing	d	e	h	h1	h2	m	n	s	w	z	M	Material	approx. kg
TM/UT620.0	EL75/65	75	65	38	100	162,5	240	345	22	70	28	M16	Steel	13,5

Color of the clamping bearings in RAL 7031

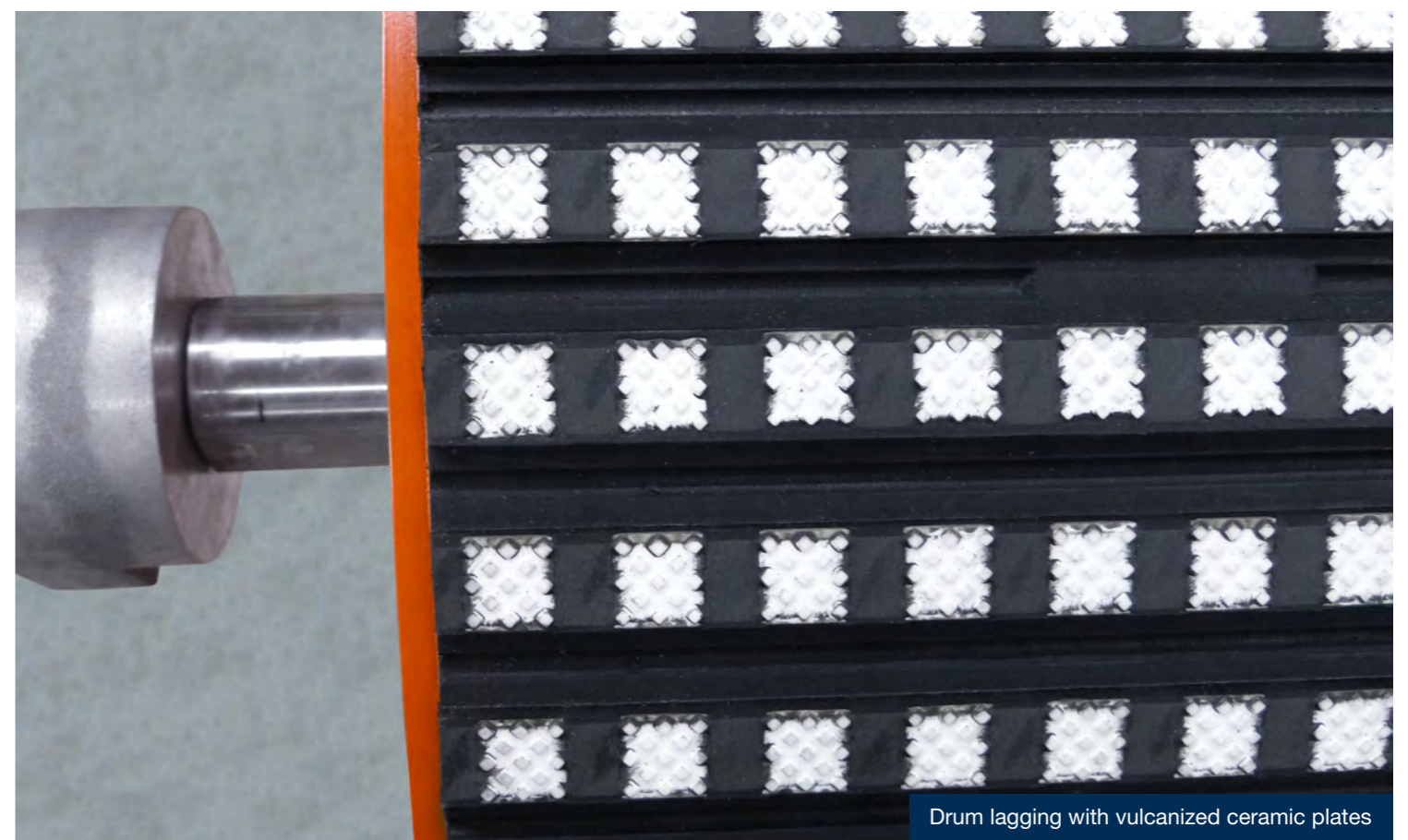

Drum lagging with vulcanized ceramic plates



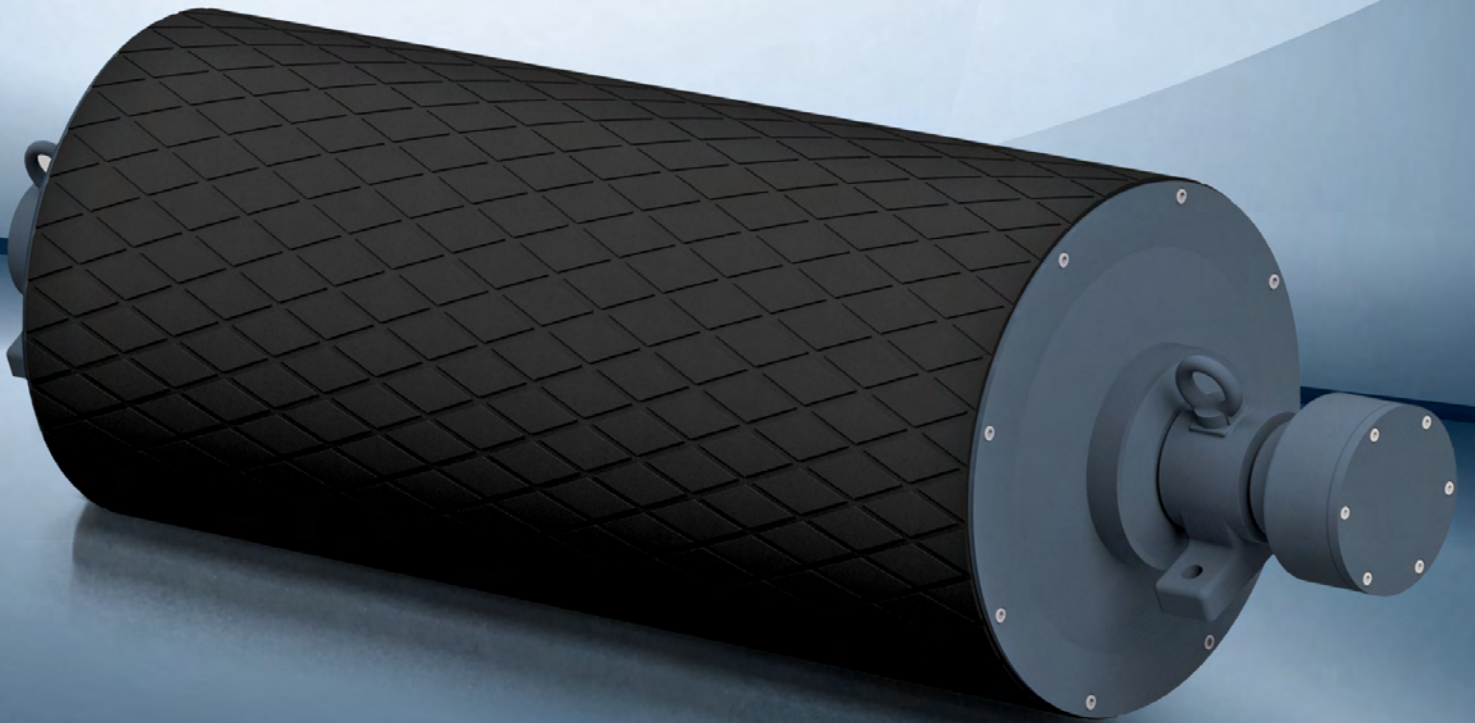

**| MODEL SERIES TM630**

# MODEL SERIES TM630

## Drum motor TM630, standard

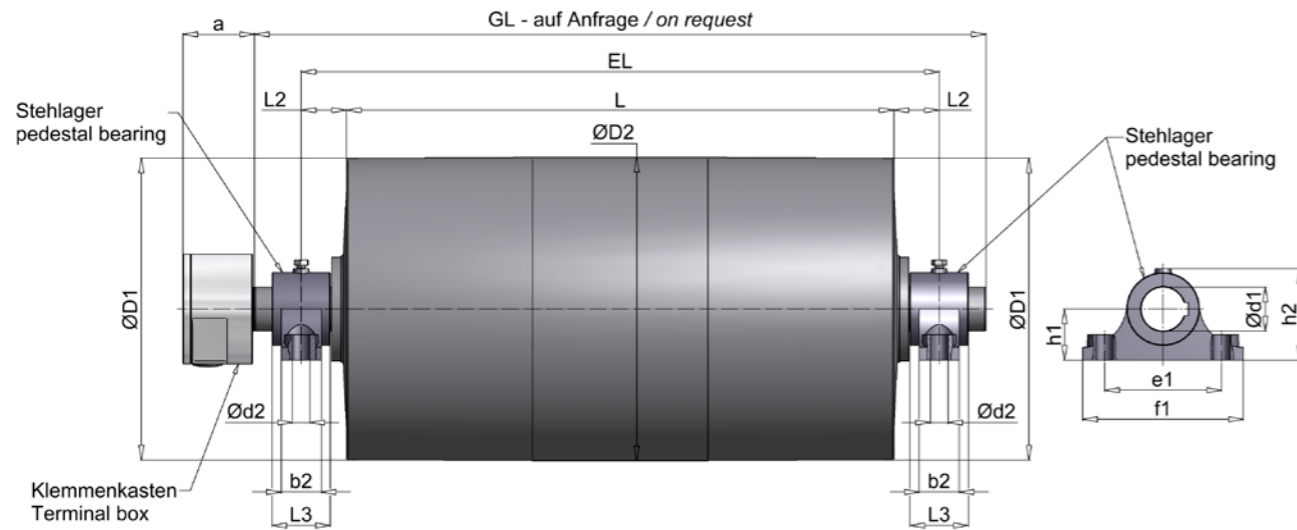

## deflection drum UT623, standard

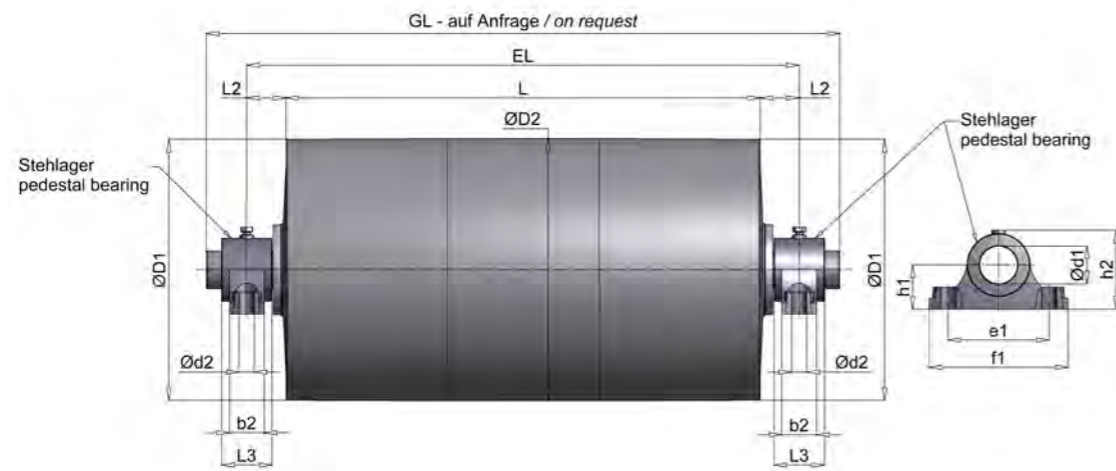

all dimensions in mm

HIMMEL® drum motor														IP66	IP67
Size	Type	Ø D1	Ø D2*	a	b2	Ø d1	Ø d2	e1	f1	h1	h2	L2	L3	EL	EL
630	TM630.1	626	630	165	80	90	26	250	320	100	183	150	117	L + 300	L + 300

HIMMEL® deflection drum															
Size	Type	Ø D1	Ø D2*		b2	Ø d1	Ø d2	e1	f1	h1	h2	L2	L3		
630	TM630.1	626	630		80	90	26	250	320	100	183	150	117		L + 300

\* Diameter with cylindrical drum body

# MODEL SERIES TM630

## Overview of services type TM630

Type	Performance	Speed	Rotational speed	Belt tension	Drum torque	Power consumption at 400 V / 50 Hz	Drum length L min.	Weight
	P2	v	n2	F	T2			L=950 mm
	[kW]	[m/s]	[1/min]	[N]	[Nm]	[A]	[mm]	[kg]
TM630.1	30,00 8-pole	1,25	38	22791	7179	57,00	950	825
		1,60	49	17807	5609			
		2,00	61	14245	4487			
		2,50	76	11394	3589			
TM630.1	37,00 6-pole	1,60	49	21969	6920	70,00	950	825
		2,00	61	17569	5534			
		2,50	76	14054	4427			
		3,15	95	11153	3513			
TM630.1	45,00 4-pole	2,50	76	17092	5384	85,00	950	845
		3,15	95	13565	4273			
		4,00	121	10683	3365			
TM630.1	55,00 4-pole	2,50	76	20902	6584	105,00	950	845
		3,15	95	16581	5223			
		4,00	121	13057	4115			

- Deviating performance data and speeds on request
- Weight incl. oil filling (ready for operation)
- Additional weight: approx. 25 kg for 100 mm additional length

Standard widths [L] : 950, 1000, 1050 ... 2000 mm from 2000 mm reinforced version.

## Execution types and options

Standard version
<ul style="list-style-type: none"> <li>• Spherically turned steel jacket</li> <li>• Bolted bearing end caps made of steel or gray cast iron</li> <li>• IP66/67</li> <li>• Steel clamping spigot</li> <li>• Spur gearbox with steel gearing (low-noise)</li> <li>• Terminal box</li> <li>• Cast steel eyelet bearing (fitted to the product as standard mounted)</li> <li>• Thermal contacts</li> </ul>

Options
<ul style="list-style-type: none"> <li>• Backstop</li> <li>• Cylindrical drum body, rubberized, galvanized (customized)</li> <li>• Stainless steel version</li> <li>• Cast iron terminal box IP66/67</li> <li>• Special friction lining on request</li> <li>• Terminal box design in stainless steel</li> <li>• Equipped with brake shaft for external brake</li> </ul>
Other versions available on request.

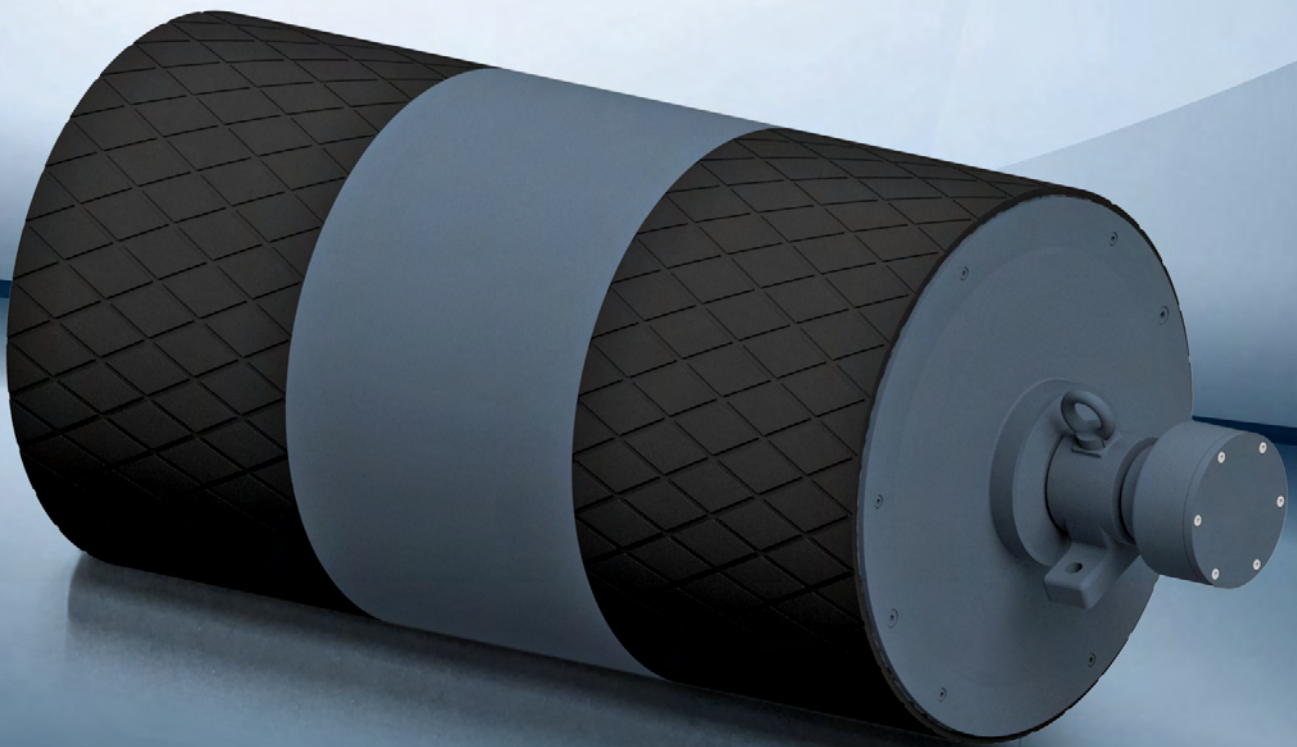

**| MODEL SERIES TM800**

# MODEL SERIES TM800

## Drum motor TM800, standard

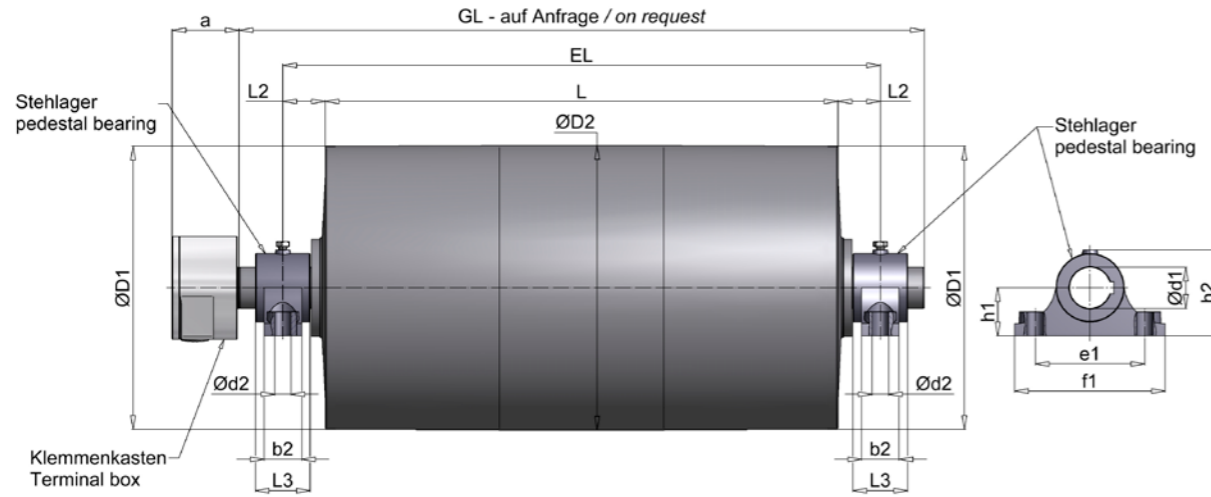

## deflection drum UT800, standard

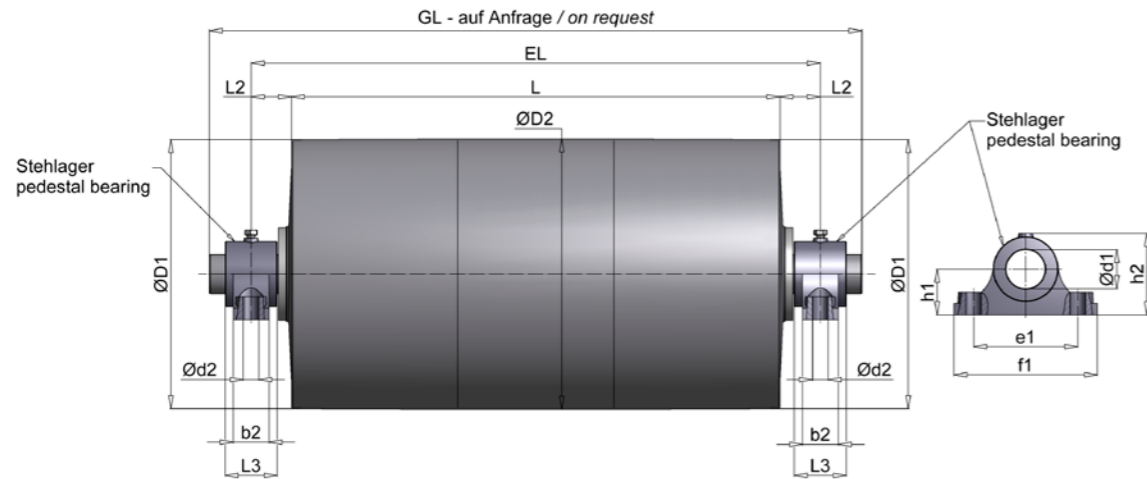

all dimensions in mm

HIMMEL® drum motor														IP66	IP67
Size	Type	Ø D1	Ø D2	a	b2	Ø d1	Ø d2	e1	f1	h1	h2	L2	L3	EL	EL
800	TM800.0	796	800	165	80	90	26	250	320	100	183	150	117		L + 300
800	TM800.1	796	800	200	120	120	33	300	370	110	213	150	160		L + 300

HIMMEL® deflection drum															
Size	Type	Ø D1	Ø D2		b2	Ø d1	Ø d2	e1	f1	h1	h2	L2	L3		
800	UT800.0	626	630		80	90	26	250	320	100	183	150	117		L + 300
800	UT800.1	626	630		120	120	33	300	370	110	213	150	160		L + 300

- Deviating performance data and speeds on request
- Weight incl. oil filling (ready for operation)
- Additional weight: approx. 25 kg for 100 mm additional length

Standard widths [L] : 950, 1000, 1050 ... 2000 mm from 2000 mm reinforced version.

For versions and options see TM630

# MODEL SERIES TM800

## Overview of services type TM800

Type	Performance	Speed	Rotational speed	Belt tension	Drum torque	Power consumption at 400 V / 50 Hz	Drum length L min.	Weight
	P2	v	n2	F	T2			
	[kW]	[m/s]	[1/min]	[N]	[Nm]	[A]	[mm]	[kg]
TM800.0	22,00 8-pole	1,25	30	16720	6688	42	950	935
		1,60	38	13058	5223			
		2,00	48	10445	4178			
		2,50	60	8358	3343			
		3,15	75	6633	2653			
TM800.0	30,00 8-pole	1,60	38	17805	7122	56	950	975
		2,00	48	14245	5698			
		2,50	60	11395	4558			
		3,15	75	9043	3617			
TM800.0	37,00 6-pole	2,00	48	17575	7030	70	950	975
		2,50	60	14055	5622			
		3,15	75	11155	4462			
		4,00	96	8783	3513			
TM800.0	45,00 4-pole	3,15	75	13565	5426	84	950	995
		4,00	96	10683	4273			
TM800.0	55,00 4-pole	3,15	75	14581	6584	95	950	995
		4,00	96	13058	5223			
TM800.1	8-pole	1,00	24	54974	20884	95	1300	2390
	6-pole	1,25	30	41300	16707			
	8-pole	1,60	38	32630	13052		1150	2150
	55,00 6-pole	2,00	48	26125	10450			
		2,50	60	20900	8360			
		3,15	75	16588	6635			
		4,00	96	13063	5225			
		4,50	108	11610	4644			
TM800.1	75,00 6-pole	1,25	30	56318	22527	134	1300	2390
		1,60	38	46240	18496			
		2,00	48	35610	14244		1150	2150
		2,50	60	28488	11395			
		3,15	75	22610	9044			
		4,00	96	17805	7122			
		4,50	108	15828	6331			
TM800.1	90,00 6-pole	1,60	38	52953	21181	158	1550	2575
		2,00	48	46240	18496			
		2,50	60	34185	13674		1400	2200
		3,15	75	27130	10852			
		4,00	96	21365	8546			
		4,50	108	18993	7597			
TM800.1	110,00 4-pole	2,00	48	54789	21915	196	1550	2575
		2,50	60	44984	17994			
		3,15	75	33160	13264		1400	2175
		4,00	96	26113	10445			
		4,50	108	23163	9265			
TM800.1	132,00 4-pole	2,50	60	53981	21592	238	1550	2615
		3,15	75	37882	15153			
		4,00	96	31338	12535		1400	2215
		4,50	108	27855	11142			

## MODEL SERIES TM1000

### Drum motor TM1000

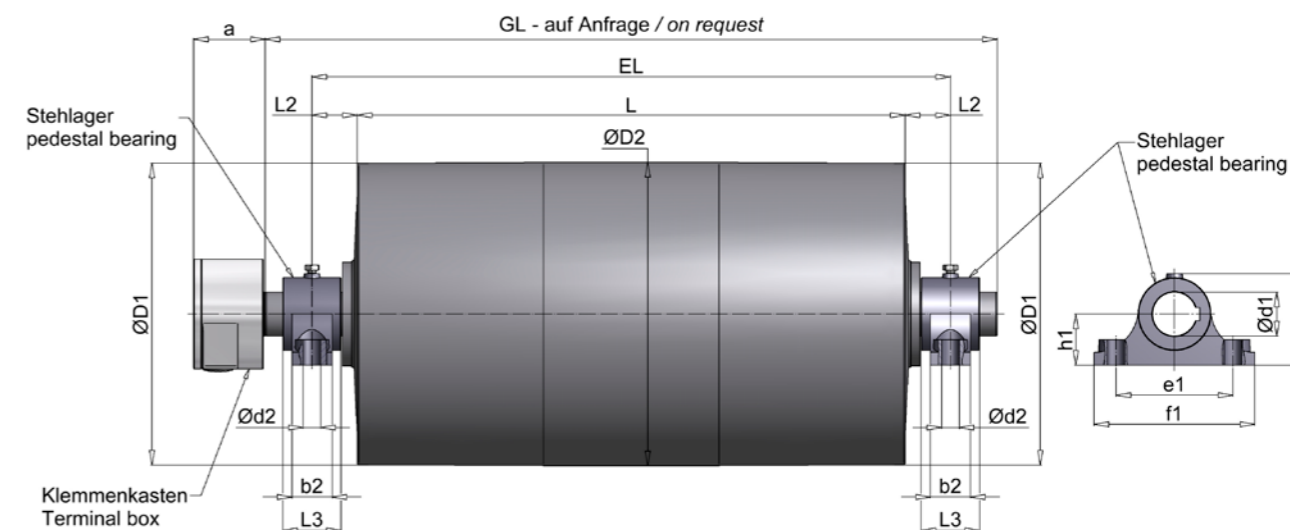

HIMMEL <sup>®</sup> drum motor													IP66 / IP67	
Size	Type	Ø D1	Ø D2	a	b2	Ø d1	Ø d2	e1	f1	h1	h2	L2	L3	EL
1000	TM1000.0 TM1000.1	1014	1020	218	130	203	50	560	717	215	412	215	208	L + 430

# MODEL SERIES TM1000

## Overview of services

Type	Performance	Speed	Rotational speed	Belt tension	Drum torque	Power consumption at 400 V / 50 Hz	Drum length L min.	Weight
	P2	v	n2	F	T2			L=950 mm
	[kW]	[m/s]	[1/min]	[N]	[Nm]			[A]
TM1000.1	160,00 6-pole	1,60	30	89280	45540	293	1450	4520
		2,00	37	71200	36310			
	160,00 4-pole	2,50	47	59530	30360	271	1400	4315
3,15		59	47800	24400				
TM1000.0	160,00 6-pole	3,00	56	49330	25160	293	1300	4520
		3,60	67	41240	21030			
	160,00 4-pole	4,50	84	32890	16770	271	1250	4065
		5,50	103	27500	14020			
		6,50	122	22170	11310			
		7,80	146	19110	9740			
		8,50	159	17390	8870			
		9,50	178	15180	7740			
TM1000.1	200,00 4-pole	2,00	37	89000	45390	345	1450	4520
		2,50	47	74410	37950			
		3,15	59	60010	30600			
		3,60	67	51720	26830			
		4,00	75	47060	24000			
		4,50	84	41110	20960			
TM1000.0	200,00 4-pole	5,50	103	34370	17530	345	1300	4250
		6,50	122	27720	14130			
		7,80	146	23890	12180			
		8,50	159	21740	11089			
		9,50	178	18970	9670			
TM1000.1	250,00 4-pole	2,50	47	93010	47430	449	1500	4700
		3,15	59	75010	38250			
		3,60	67	64650	32970			
		4,00	75	58830	30000			
TM1000.0	250,00 4-pole	4,50	84	51390	26200	449	1350	4435
		5,50	103	42950	21900			
		6,50	122	34650	17650			
		7,80	146	29860	15230			
		8,50	159	27170	13850			
		9,50	178	23710	12000			

- Deviating performance data and speeds on request
- Weight incl. oil filling (ready for operation)
- Additional weight: approx. 130 kg on 100 mm additional length

Standard widths [L] : 1250, 1300, 1350 ... 2500 mm

# MODEL SERIES TM1000

## Execution types and options

Standard version
<ul style="list-style-type: none"> <li>• Spherically turned steel shell + ceramic coating</li> <li>• Screwed bearing end caps made of steel or gray cast iron</li> <li>• IP 66/67</li> <li>• Clamping spigot made of steel</li> <li>• spur gear with steel gearing (low noise)</li> <li>• Cast iron terminal box</li> <li>• Cast steel eye bearings (mounted on the product as standard)</li> <li>• Thermal contacts</li> <li>• Color RAL 7001</li> </ul>

Optionen
<ul style="list-style-type: none"> <li>• Backstop</li> <li>• Equipped with brake shaft for external brake</li> </ul> <p>Other versions available on request.</p>



Drum motors in the bulk goods sector

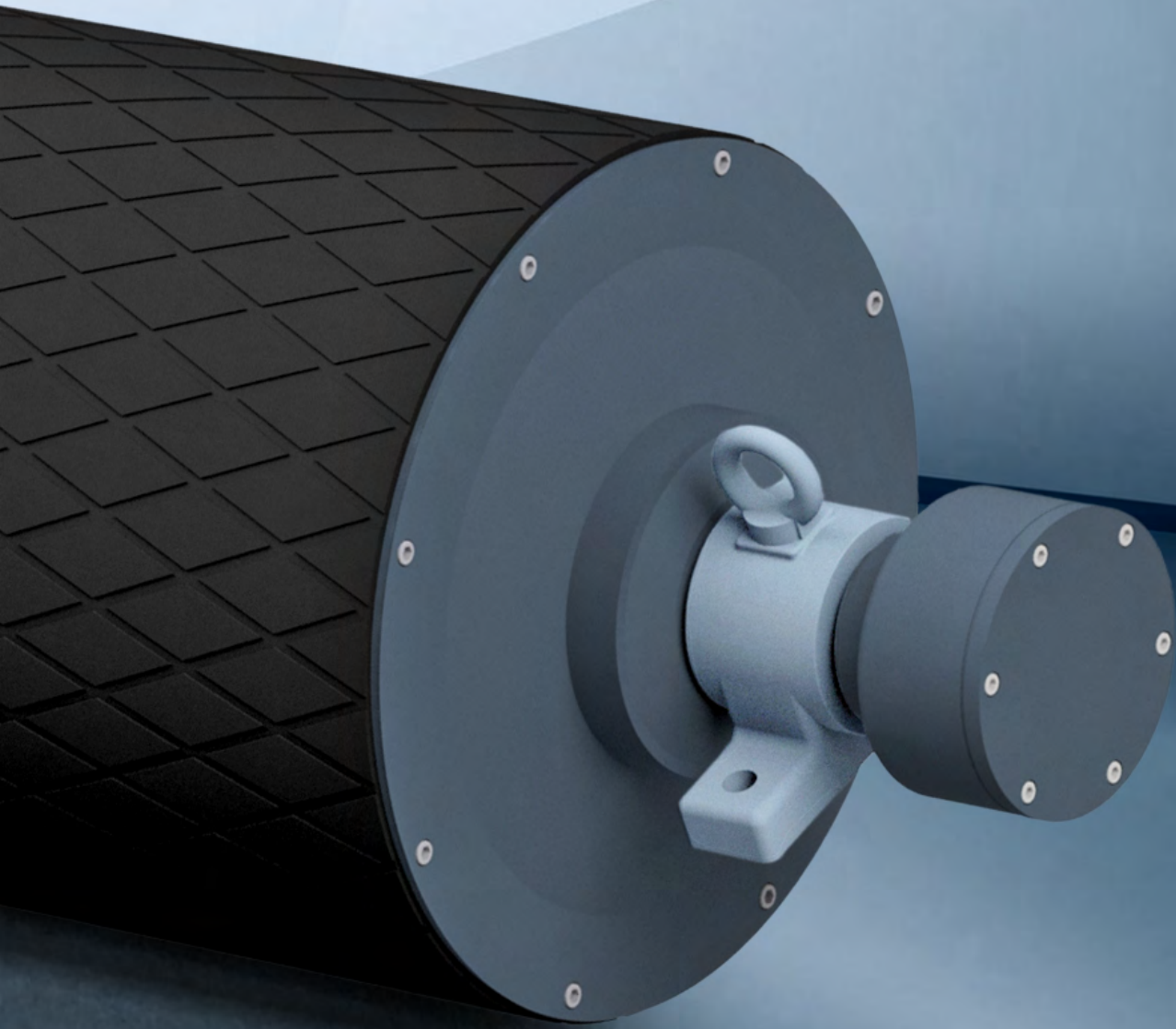

# MODEL SERIES TM165-TM620 WITH PEDESTAL BEARING

## MODEL SERIES TM165-TM620SL

### Drum motor TM165-TM620, pedestal bearing

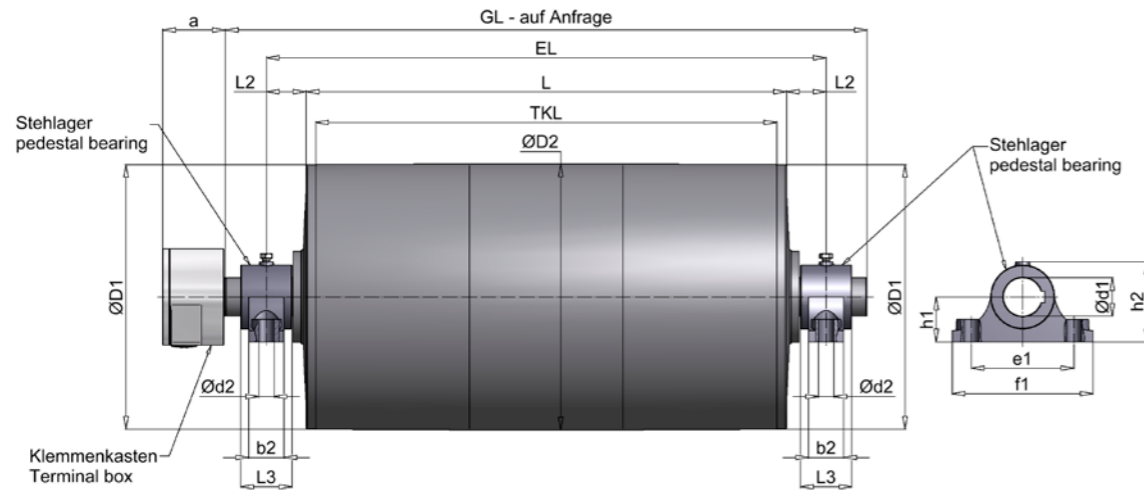

### Deflection drum UT165-UT620, pedestal bearing

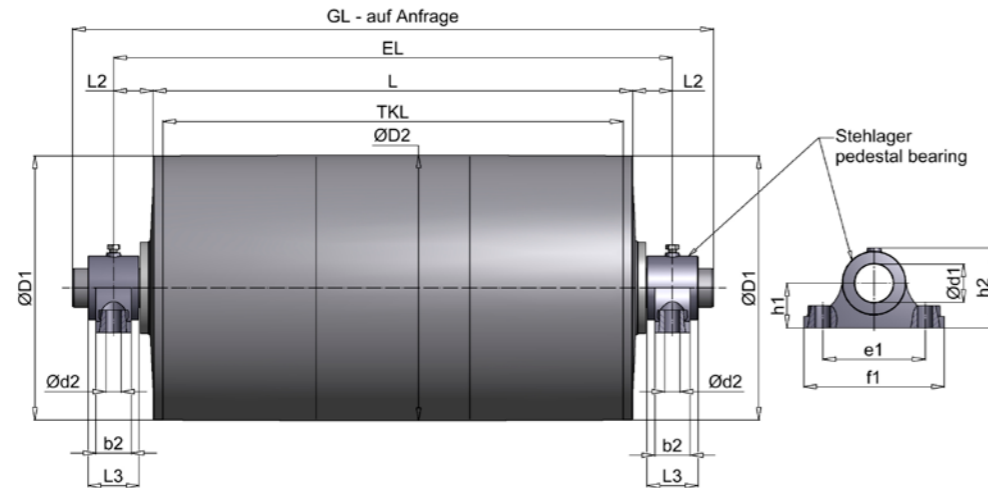

Standard widths of HIMMEL® drums can be found  
for versions with clamping bearing.

## MODEL SERIES TM165-TM620SL

### Selection tables HIMMEL® drum motor with pedestal bearing TM165SL-TM620SL

HIMMEL® drum motor														IP65	IP66/67
Size	Type	Ø D1	Ø d2	a	b2	Ø d1	Ø d2	e1	f1	h1	h2	L2	L3	EL	EL
165	TM165.1	165	164	95	45	40	15	120	160	50	95	38,5	60	L + 77	L + 104
HIMMEL® deflection drum															
165	TM165.1	165	164	-	45	40	15	120	160	50	95	38,5	60	L + 77	L + 104

HIMMEL® drum motor															
Size	Type	Ø D1	Ø d2	a	b2	Ø d1	Ø d2	e1	f1	h1	h2	L2	L3	EL	EL
216	TM216.0	216	213,5	95	45	35	15	120	160	50	95	45	60	L + 90	L + 122
216	TM216.1	216	213,5	95	45	40	15	120	160	50	95	50	60	L + 100	L + 134
HIMMEL® deflection drum															
216	TM216.0	216	213,5	95	45	35	15	120	160	50	95	45	60	L + 90	L + 122
216	TM216.1	216	213,5	95	45	40	15	120	160	50	95	50	60	L + 100	L + 134

HIMMEL® drum motor															
Size	Type	Ø D1	Ø d2	a	b2	Ø d1	Ø d2	e1	f1	h1	h2	L2	L3	EL	EL
321	TM321.0	321	317,5	95	45	40	15	120	160	50	95	50	60	L + 100	L + 150
321	TM321.1	321	317,5	95	50	45	19	140	190	60	110	57	70	L + 114	L + 156
HIMMEL® deflection drum															
321	TM321.0	321	317,5	-	45	40	15	120	160	50	95	50	60	L + 100	L + 150
321	TM321.1	321	317,5	-	50	45	19	140	190	60	110	57	70	L + 114	L + 156

HIMMEL® drum motor															
Size	Type	Ø D1	Ø d2	a	b2	Ø d1	Ø d2	e1	f1	h1	h2	L2	L3	EL	EL
415	TM415.0	415	413	100	50	45	19	140	190	60	110	57	70	L + 114	L + 156
415	TM415.1	415	413	100	55	60	24	160	220	70	125	62	80	L + 124	L + 194
HIMMEL® deflection drum															
415	TM415.0	415	413	-	50	45	19	140	190	60	110	57	70	L + 114	L + 156
415	TM415.1	415	413	-	55	60	24	160	220	70	125	62	80	L + 124	L + 194

HIMMEL® drum motor															
Size	Type	Ø D1	Ø d2	a	b2	Ø d1	Ø d2	e1	f1	h1	h2	L2	L3	EL	EL
518	TM518.0	518	513	100	55	60	24	160	220	70	125	62	80	L + 124	L + 194
518	TM518.1	518	513	100	70	75	28	210	270	90	165	80	100	L + 160	L + 220
HIMMEL® deflection drum															
518	TM518.0	518	513	-	55	60	24	160	220	70	125	62	80	L + 124	L + 194
518	TM518.1	518	513	-	70	75	28	210	270	90	165	80	100	L + 160	L + 220

HIMMEL® drum motor															
Size	Type	Ø D1	Ø d2	a	b2	Ø d1	Ø d2	e1	f1	h1	h2	L2	L3	EL	EL
620	TM620.0	620	618	100	70	75	28	210	270	90	165	80	100	L + 160	L + 220
HIMMEL® deflection drum															
620	TM620.0	620	618	-	70	75	28	210	270	90	165	80	100	L + 160	L + 220



## TECHNICAL EXPLANATIONS

### Additional equipment

TMType	60	82	113	138	165	216	321	415	518	620	630	800
Mechanical Backstop	X	X	X	X	X	X	X	X	X	X	X	X
Brake electromagnetic		X	X	X	X	X	X	X	X	X	X	X
Winding thermostat		X	X	X	X	X	X	X	X	X	X	X
Stainless steel version	X	X	X	X	X	X	on request					
Black rubber coating		X	X	X	X	X	X	X	X	X	X	X
Rubber coating white / food quality		X	X	X	X	X						
Galvanized finish	X	X	X	X	X	X	X	X	X	X		
Motor with 2 speeds					X	X	X	X	X	X		
Labyrinth seal IP 66	X	Standard	Standard	Standard	Standard	X	X	X	X	X		
Protection class IP69K		X	X	X	X							
Cable version	Standard	Standard	Standard	Standard	Standard	X	X					
Version with terminal box			X	X	X	Standard	Standard	Standard	Standard	Standard	Standard	Standard
Version for 2 voltages		X	X	X	X	X	X	X	X	X	X	X
with pedestal bearing					X	X	X	X	X	X	Standard	Standard
with clamping bearing	X	X	X	X	X	X	X	X	X	X		

## TECHNICAL EXPLANATIONS

### Rubberized HIMMEL® drum motors with keyway

With a central wedge groove in the coating of the drum, conveyor belts with a correspondingly welded wedge can be used. In this design, good central running of the conveyor belt can be

guaranteed. However, the belt should be guided via the slider or roller bed.

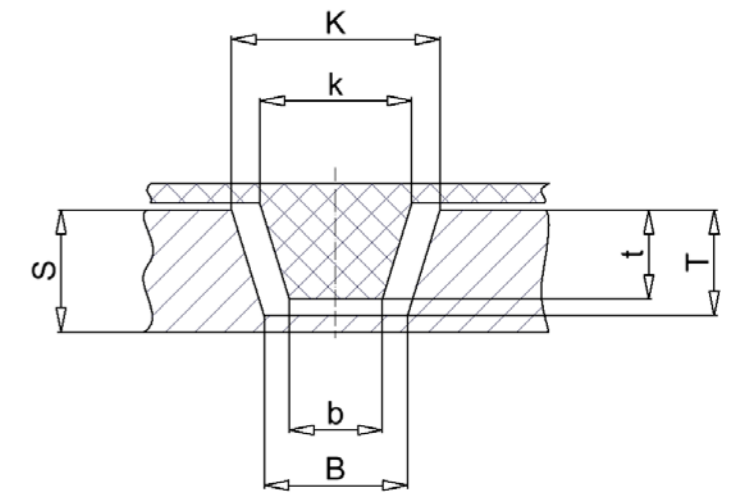

V -Groove	S <sub>min.</sub> [mm]	S <sub>max.</sub> [mm]	Groove			Wedge		
			K [mm]	B [mm]	T [mm]	k [mm]	b [mm]	t [mm]
<b>K6</b>	6	8	10	8	5	6	4	4
<b>K8</b>	6	8	12	8	6	8	5	5
<b>K10</b>	8	10	14	10	7	10	6	6
<b>K13</b>	10	12	17	11	9	13	7,5	8
<b>K15</b>	10	12	19	13	9	15	9,5	8
<b>K17</b>	12	14	21	13	12	17	9,5	11

## TECHNICAL EXPLANATIONS

### Coatings and sprockets for modular plastic belts

Our HIMMEL® drum motors can be designed with profiled coatings or with sprockets to drive form-fit modular plastic conveyor belts. We are familiar with various profiles from well-known

manufacturers such as Ammeraal/Uni-chains, Habasit, Intralox, Scanbelt, Siegling and Volta.



Drum motor with profiled coating for driving modular conveyor belts

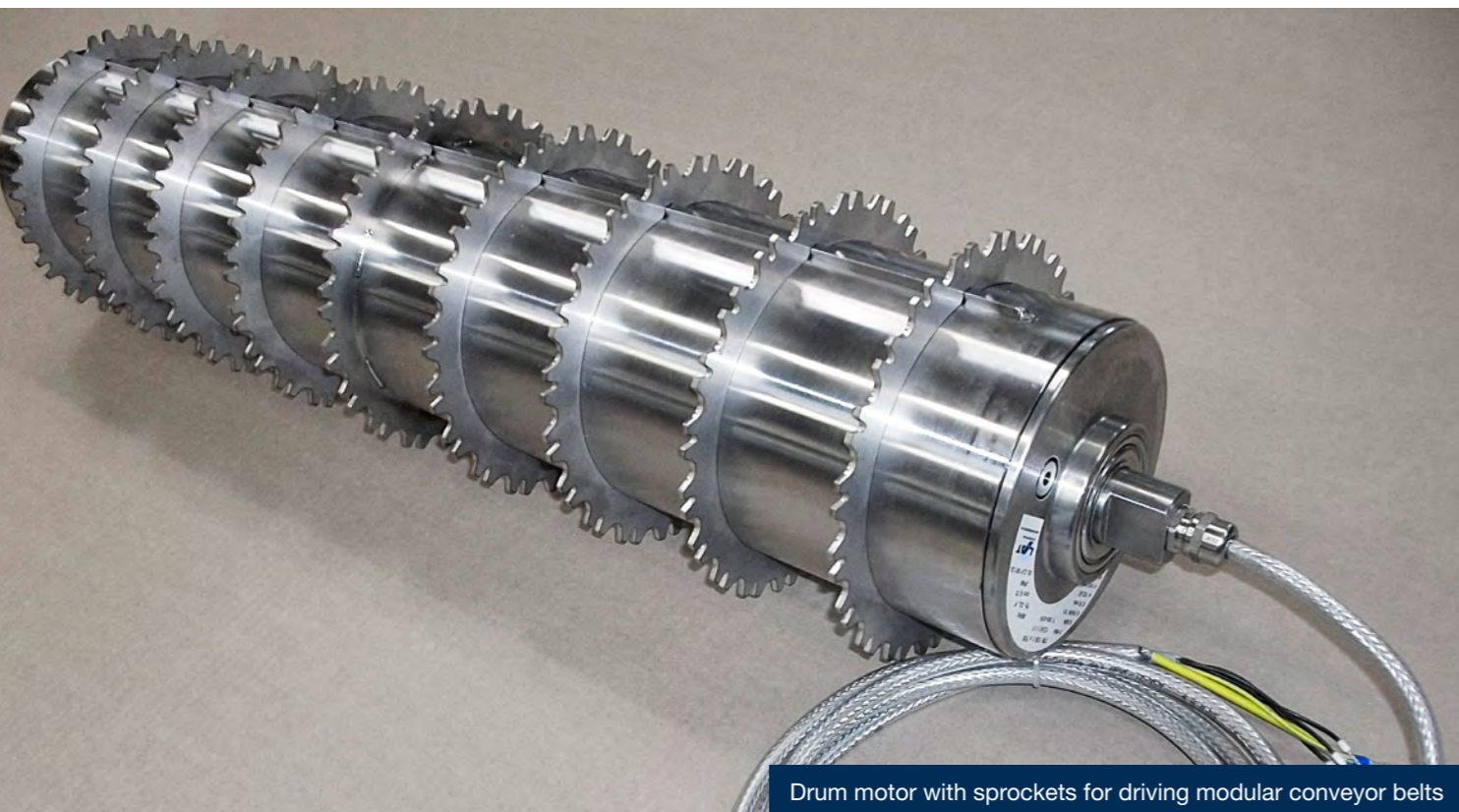

Drum motor with sprockets for driving modular conveyor belts

## TECHNICAL EXPLANATIONS

### Electrical connection

#### Operating voltages

To determine the motor winding, the operating voltage and type of switch-on must be clearly specified.

Standard winding design for HIMMEL® drum motors:

Motors up to 2.2 kW for 230/400 V delta/star.

Motors from 3.0 kW for 400 V delta.

Special voltages and frequencies are available on request.

#### Connection

During commissioning, the operating voltage available at the place of use must be compared with the factory-switched voltage. If they do not match, the circuit on the terminal plate must be changed. The terminal plate is accessible after opening the terminal box.

All HIMMEL® drum motors must be provided with a protective conductor connection (VDE 0530).

#### Motor protection

Fuses are not motor protection, but cable protection against short circuits. To protect the winding of a three-phase motor against thermal overload due to blocking and two-phase operation, the following can be provided on request:

**PTC thermistor** – Temperature sensor (internal) (PTC) in conjunction with a trigger device.

**Winding earthing contact** (internal) (WT) as normally closed or normally open contact in the stator winding, which switches the motor off via a contactor in the event of an overload. These do not protect if the rotor is blocked, so additional motor protection switches must be provided if necessary.

**Motor protection switch** (external) with bimetal release, which triggers in the event of an impermissible power supply.

# TECHNICAL EXPLANATIONS

## Frequency inverter



© 2018 Siemens AG

HIMMEL® drum motors can be operated with a frequency converter. This allows the circumferential speed to be controlled. In addition, starts and stops can be controlled smoothly. Three-phase motors can be operated on a single-phase network with

the appropriate frequency inverter. On request, we can offer you the right frequency inverter for the HIMMEL® drum motor.

# TECHNICAL EXPLANATIONS

## Standard connection diagram for three-phase HIMMEL® drum motor

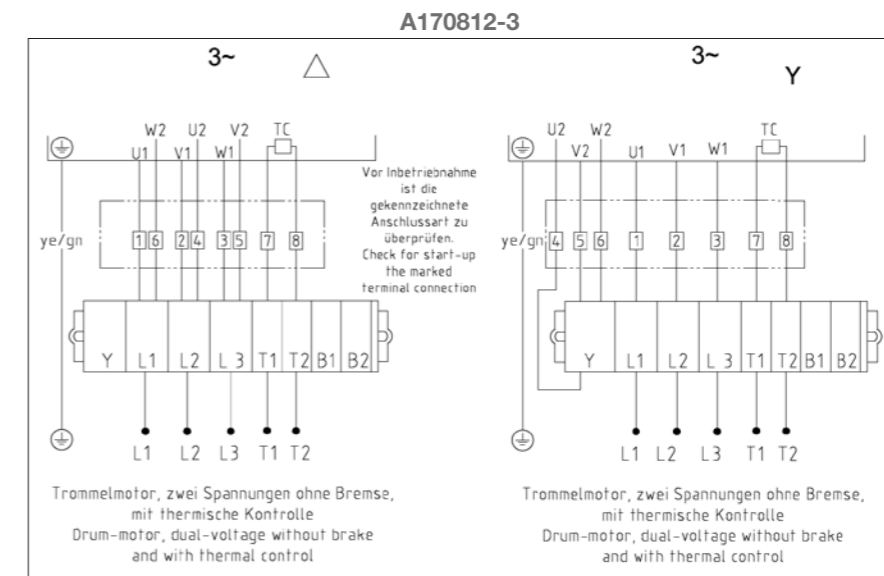
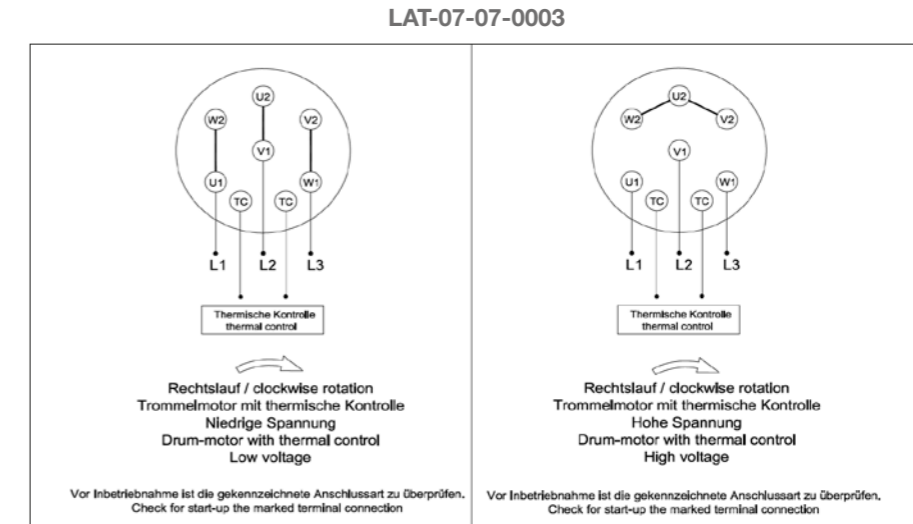

## Electrical connection HIMMEL® drum motor with cable connection 3 ~ motor

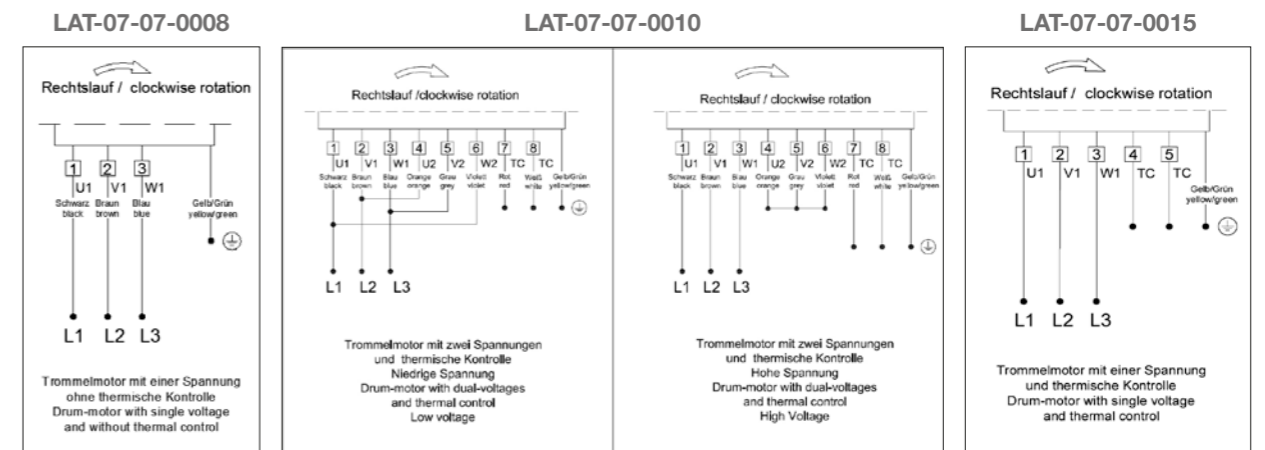

# TECHNICAL EXPLANATIONS

## Electrical connection versions

	TM60 – TM82	TM113 – TM165	TM216 – ...
Type B: Angled cable gland, plastic with 3 m cable			on request
Type C: Variable cable design, internal strain relief with 3 m cable			on request
Type D: Straight cable gland with 3 m cable			on request
Type E: elbow fitting, stainless steel with 3 m cable			on request
Type A: Terminal box			
	TM113 – TM165		
	TM216 – TM321		
	TM415 – TM620		

**Caution:** If the HIMMEL® drum motor is equipped with an encoder or brake, a shielded cable should be used. The same

applies when connecting the motor to a frequency inverter or similar control device.

# TECHNICAL EXPLANATIONS

## Sealings IP65 - IP69K

	IP 65	IP 66	IP 67	IP 69K
TM60.1	 Standard		on request	on request
TM82.1 / TM113.1 / TM138.1 / TM165.1 / TM216.0	on request	 Standard	on request	
TM216.1	 Standard			on request
TM321.0 / TM321.1 / TM415.0 / TM415.1 / TM518.0	on request	 Standard		on request
TM518.1 / TM620.0		 Standard		on request

# TECHNICAL EXPLANATIONS

## HIMMEL® drum motors with electromagnetic brake

### HIMMEL® TM82 to 620 drum motors with internally built-in brake

HIMMEL® drum motor with built-in spring-applied brake, specially developed for under-oil operation.

The switching frequency and the masses to be braked determine the brake size. For safety reasons, a spring-applied brake is always used, which brakes immediately by means of spring force in the event of a power failure or when the motor is swit-

ched off. The brake is also released when the motor is switched on. The motor and brake are connected in the terminal box. The brake is supplied with alternating current, usually 230 volts at 50 Hz. The externally mounted rectifier supplies the brake winding with direct current. It is advantageous to use a rapid brake switching device to prevent the motor from starting against the closed brake.

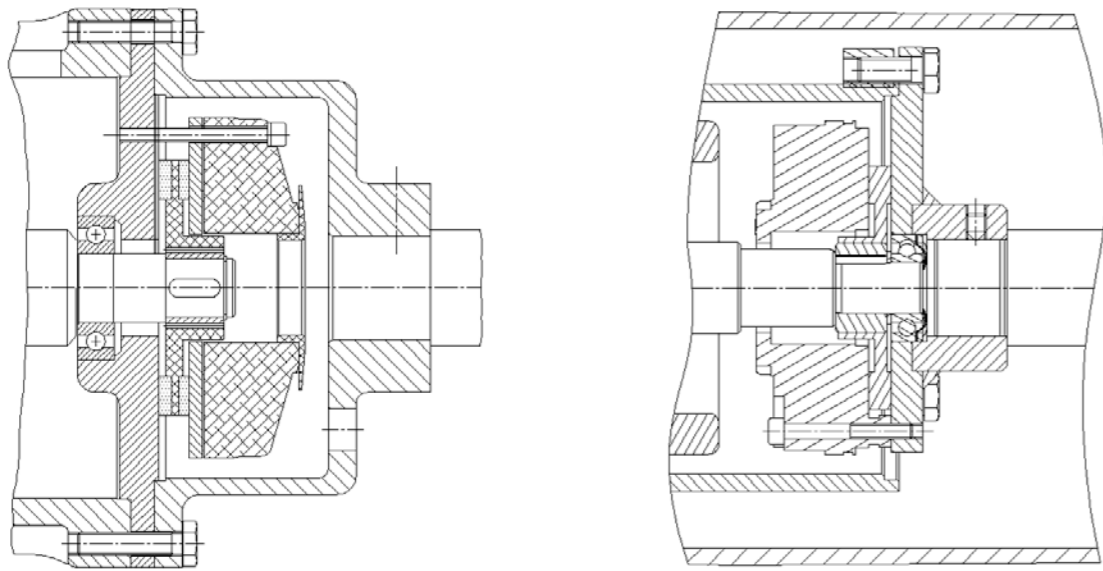

### Standard connection diagram for brake rectifier

Brake only switched on AC side!

With contact K: Brake switched on the DC and AC sides switched!

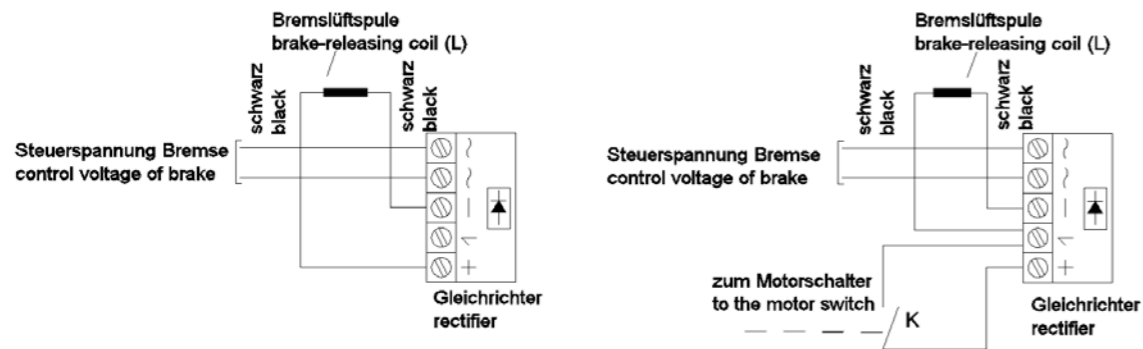

# TECHNICAL EXPLANATIONS

## HIMMEL® drum motor with built-in backstop

### General

All HIMMEL® drum motors are available with a built-in backstop. For smaller types with roller bearing freewheel, for larger types with centrifugal lift-off backstop. This prevents the stopped drive from running backwards on rising conveyors. The locking direction must be specified when ordering, as seen from the terminal box. The backstop is completely maintenance-free.

### Direction of rotation

An arrow on the end shield indicates the free direction of rotation, the opposite direction is blocked. Pay attention to the phase sequence when connecting. After connecting in phase sequence L1 - L2 - L3 on the terminal board to U - V - W, the drum motor will run in the free direction of rotation. Do not attempt to run the drum motor in the blocking direction!

## Design examples

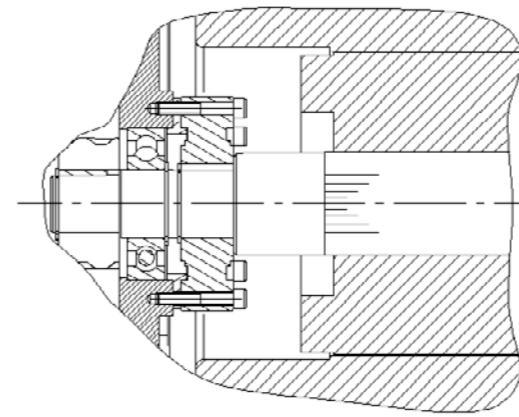

Application for power from 5.5 kW

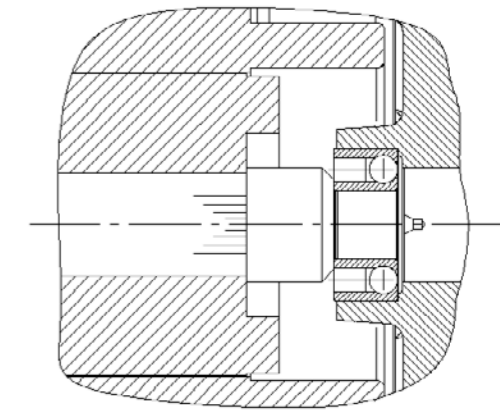

Application for power less than 4 kW

# TECHNICAL EXPLANATIONS

## Selecting the drive

Calculation of the resistance to movement (unit loads)

The following calculation data, based on the determination method in accordance with DIN 22101, is used to roughly determine the resistance to movement of belt conveyors.

The forces resisting the movement of a belt conveyor system consist of friction, weight and mass forces in the stationary operating state. The power requirement of the conveyor is the product of these movement resistances and the belt speed.

To calculate the resistances, these are divided into main, secondary, incline and special resistances. The sum of these movement resistances is equal to the circumferential force F to be transferred from the drive pulley to the belt, i.e.:

$$F = 9.81 (F_0 + F_1 + F_2 + F_3) \text{ [N]}$$

The required drive power is then calculated as follows:

$$P = F \cdot v / 1000 \cdot \eta_t \text{ [kW]}$$

**Formula symbols and units:**

- F = required belt tension [N]
- $m'_n$  = belt weight in [kg/m]
- $m'_{pr}$  = weight of the moving masses of the belt conveyor in [kg/m]
- $m'_{m1}$  = Conveyed material weight in [kg/m]
- $C_1$  = Coefficient of friction between conveyed goods and belt
- $C_2$  = Coefficient of friction between belt and sliding plate (upper run)
- L = Axis distance between drum motor and deflection drum [m]
- H = Height difference [m]
- v = Belt speed in m/s
- P = Drive power for entire belt [kW]
- $\eta_t$  = Drum motor efficiency [approx. 0.94]

Förderart form of conveyance	ohne Beladung without load	horizontaler transport horizontal transportation	ansteigendes Band increasing belt-drive	Staubetrieb duty on accumulation
rollender Transport rolling conveyance	$F_0=0,04 (2m'n + m'pr) L$	$F_1=0,04 \times m'm_1 \times L$	$F_2=m'm_1 \times H$	$F_3=m'm_1 \times L \times C_1$
gleitender Transport sliding conveyance	$F_0=1,1 \times m'n \times L \times C_2$	$F_1=1,1 \times m'm_1 \times L \times C_2$	$F_2=m'm_1 \times H$	$F_3=m'm_1 \times L \times C_1$

# TECHNICAL EXPLANATIONS

Calculation of the movement resistance (piece goods)

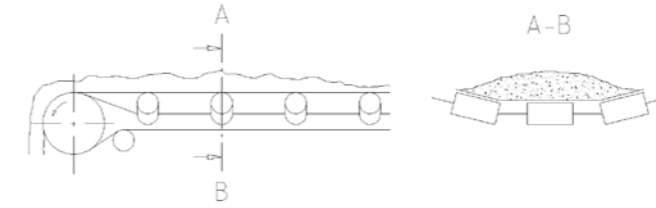

The power required by a uniformly loaded belt conveyor system with a filling degree  $\phi$  in the range 0.7 to 1.1 at the circumference of the drive pulley(s) is  $P = F \cdot v$

Taking into account the factors C and G<sub>m</sub> given in the tables, an approximate determination of the successful drive power is therefore possible: (DIN 22101)

$$P = C \cdot f \cdot L / 376 (3.6 - G_m \cdot v + Q_t) + Q_t \cdot H / 367 \text{ [kW]}$$

**Formula symbols and units:**

- P = Drive power for entire belt [kW]
- C = Coefficient "C" for belt, ball bearing, etc. (see table A)
- f = Coefficient "f" takes into account the influence of operating conditions due to deflection rollers and idlers. (factor 0.025-0.030)

- L = Axis distance between drum motor and deflection drum [m]
- G<sub>m</sub> = Weight of the belt and the moving parts of the conveyor belt in kg/m (see Table B)
- v = Belt speed in m/s
- Q<sub>t</sub> = Theoretical delivery rate in tons per hour (t/h)
- H = Height difference [m]
- B = Belt width in mm

The calculation scheme shown above does not include the additional power required for wipers, sealing strips, etc.

Table "A"

Standard values for coefficient "C" for belt conveyor system with filling level "phi" in the range 0.7 to 1.1											
L [m]	3	4	5	6	7	8	10	16	20	25	32
C	9,0	7,6	6,6	5,9	5,1	4,5	4,1	3,6	3,2	2,9	2,6
L [m]	40	50	63	80	100	125	160	200	250	300	400
C	2,4	2,2	2,0	1,92	1,78	1,65	1,59	1,45	1,38	1,31	1,25
L [m]	500	600	700	800	900	1000	1200	1400	1600	1800	2000
C	1,20	1,17	1,14	1,12	1,10	1,09	1,09	1,06	1,06	1,05	1,05

Table "B"

B [m] Belt width	500	600	650	800	1000	1200	1400	1600	1800
G <sub>m</sub> [kg/m] for standard conveyor belts	17	26	28	40	56	70	85	105	120
G <sub>m</sub> [kg/m] For heavy and profiled belts	20	30	32	45	63	80	110	135	160

# TECHNICAL EXPLANATIONS



## Lubrication

### Oil types

All HIMMEL® drum motors are supplied ready for operation with the required oil filling. The factory filling consists of SAE 100 gear oil with the following technical specifications: Viscosity CLP100 cST/40 °C or 8°Engler/50 °C, the pour point is -20 °C. The oil is suitable for ambient temperatures from -20 °C to +50 °C.

When using other types of oil, it must be ensured that the oil does not contain any additives that could damage the motor insulation. In addition, oil types containing graphite, molybdenum sulphide or other electrically conductive components must NOT be used, as this will damage the motor.

NSF/H1 quality (food industry) can also be supplied on customer request.

### Oil change

An oil change is not necessary, but can be carried out for special reasons. A change is recommended after 10,000 operating hours.

There are two screw plugs on the flange of the HIMMEL® drum motor, on the side of the terminal box. When changing the oil, remove the two screws and turn the HIMMEL® drum motor until the outer threaded opening is turned downwards so that the old oil can run out.

**CAUTION:** It must be ensured that the "UP" marking on the connection side or output side never points downwards, as otherwise cooling/lubrication is no longer guaranteed.

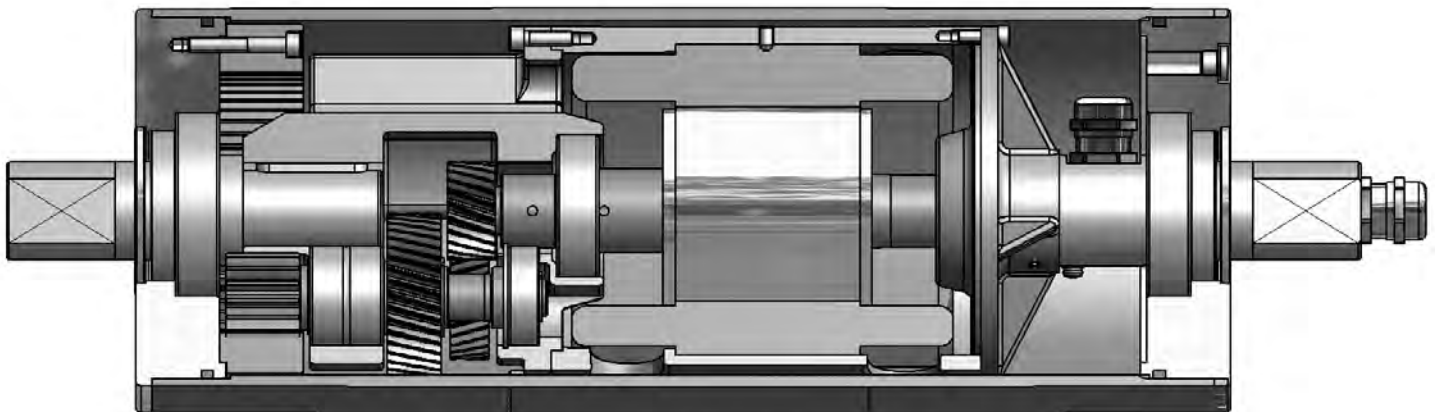



## **| SIMULATION**

Optimum winding design and structural-mechanical evaluation of the components are of crucial importance, especially when it comes to the highest demands placed on our motors. All electrical data is calculated by our experts. New winding designs are checked and adapted using numerical simulation with the latest standards. This ensures that the optimum is always achieved under the given framework conditions.

Mechanical design is also supported by modern software solutions that help us with a wide range of issues. For example, the bearing service life can be calculated taking a wide range of factors into account.

We also use numerical methods such as the finite element method (FEM). This enables us to detect weak points at an early stage in the development process and carry out contour optimization if necessary.





## **| TEST FIELD**

The factory test facility includes two test benches for HIMMEL® drum motors, whereby all HIMMEL® drum motors are subjected to a test run after assembly.

In addition to a high-voltage test, all electrical and mechanical data is checked. If required, we can also test our HIMMEL® drum motors on a performance test bench or on more customer-specific test benches.



# YOUR DRIVE FOR SUCCESS

**LAT Maschinen- und Antriebstechnik GmbH & Co. KG**

Venneweg 28 | 48712 Gescher

Germany

Fon: +49 (0) 2542 / 910-0

Fax: +49 (0) 2542 / 910-290

E-Mail: [info@himmelinfo.de](mailto:info@himmelinfo.de)

Web: [www.himmelinfo.de](http://www.himmelinfo.de)



**HIMMEL**<sup>®</sup>

technologies

YOUR DRIVE FOR SUCCESS.

**LAT**<sup>®</sup>  
ANTRIEBSTECHNIK