

## CHAIN, BELT AND SLIDING GUIDES

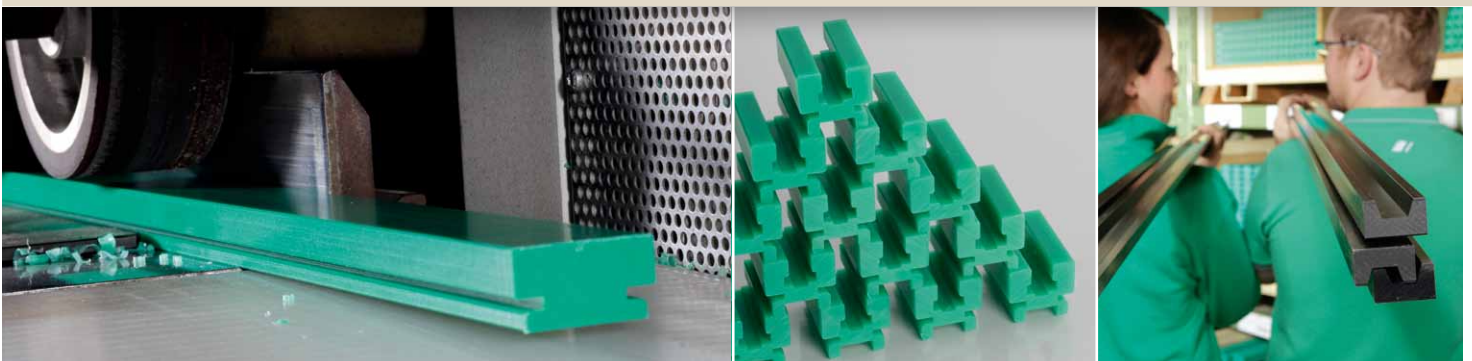

## CHAIN, BELT, AND SLIDING GUIDES – TABLE OF CONTENTS

Introduction	<b>64</b>
Overview of Chain Guides	<b>65</b>
Special Profiles	<b>66 – 67</b>
Chain, Belt, and Sliding Guides	<b>68</b>
Construction with Plastic Guides	<b>69</b>
Steel C Profiles	<b>70</b>
Selection Table for Steel C Profiles	<b>71</b>
Fastening of Steel C Profiles	<b>72</b>
T-Head Bolts	<b>73</b>
Fixing the Steel C-Profile with stud welding bolts	<b>74</b>
Chain Guides for Roller Chains as per DIN 8187	<b>75 – 91</b>
Types: T, CT, T-Duplex, CT-Duplex, T-Triplex, CT-Triplex, TU, CTU, TS, CTS, U, CU, K, CK, CKG, CKG 14H, CKG 15V, ETA	
Chain Guides for Round Link Chains as per DIN 766/764	<b>92 – 93</b>
Types: R, CRU, CRG, CRO	
Overview of Belt Guides/Belt Guides	<b>94 – 99</b>
Types: RR, RRC, KR, KRC, FR, FRC, FK, FKC	
Chain Racks	<b>100</b>
Profiles for Conveying and Transportation	<b>101 – 109</b>
Sliding Guides, Type CF, Rail guides as insertion and Clip Profiles, Bands, Slip-On Profiles, Profiles for Slat Band Chains, Curve Guides for Slat Band Chains	
Guides for modular belts	<b>110 – 112</b>

# OVERVIEW OF CHAIN GUIDES

For roller chains (DIN 8187) and round link chains (DIN 766/764)

Murtfeldt offers an extensive standard range of guides for roller chains. We have a total of 20 different types of guide for roller chains and four for round link chains. You can also choose between our high-quality Original Material "S"<sup>®</sup> green and our more economical Material "S"<sup>®</sup> 1000 green.

## Chain guides for roller chains as per DIN 8187 (DIN 8188 catalogue on request)

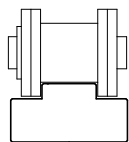

Type T – page 75

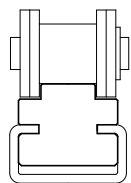

Type CT – page 76

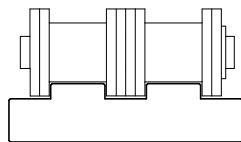

Type T-Duplex – page 77

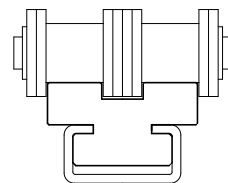

Type CT-Duplex – page 78

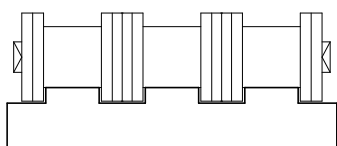

Type T-Triplex – page 79

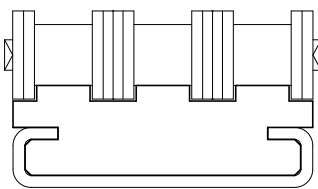

Type CT-Triplex – page 80

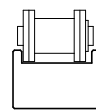

Type TU – page 81

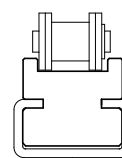

Type CTU – page 81

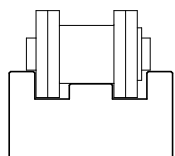

Type TS – page 82

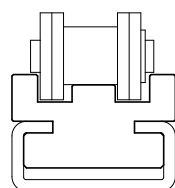

Type CTS – page 83

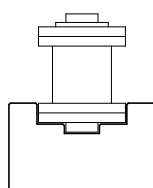

Type U – page 84

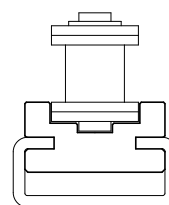

Type CU – page 85

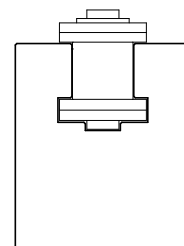

Type K – page 86

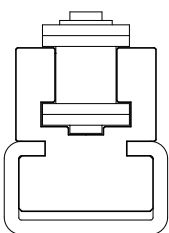

Type CK – page 87

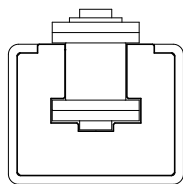

Type CKG – page 88

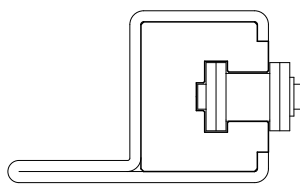

Type CKG 14H – page 89

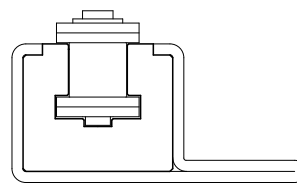

Type CKG 15V – page 90

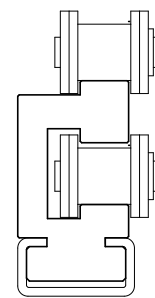

Type ETA – page 91

## Chain guides for round link chains as per DIN 766/764

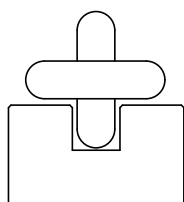

Type R – page 92

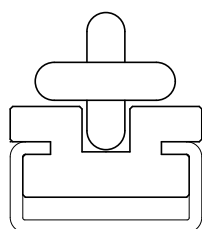

Type CRU – page 92

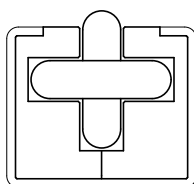

Type CRG – page 93

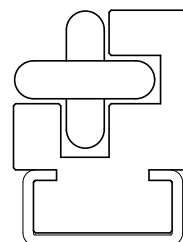

Type CRO – page 93

## SPECIAL PROFILES

When the standard designs are not enough

Our standard range of profiles offers many solutions for equipping your machines. Should we not have the design you require in our range, we would be happy to manufacture it to your individual specification. Get in touch with our application engineers or our Field Sales team.

We can also offer you the option of processing documents and drawings online and in real time together with our staff.

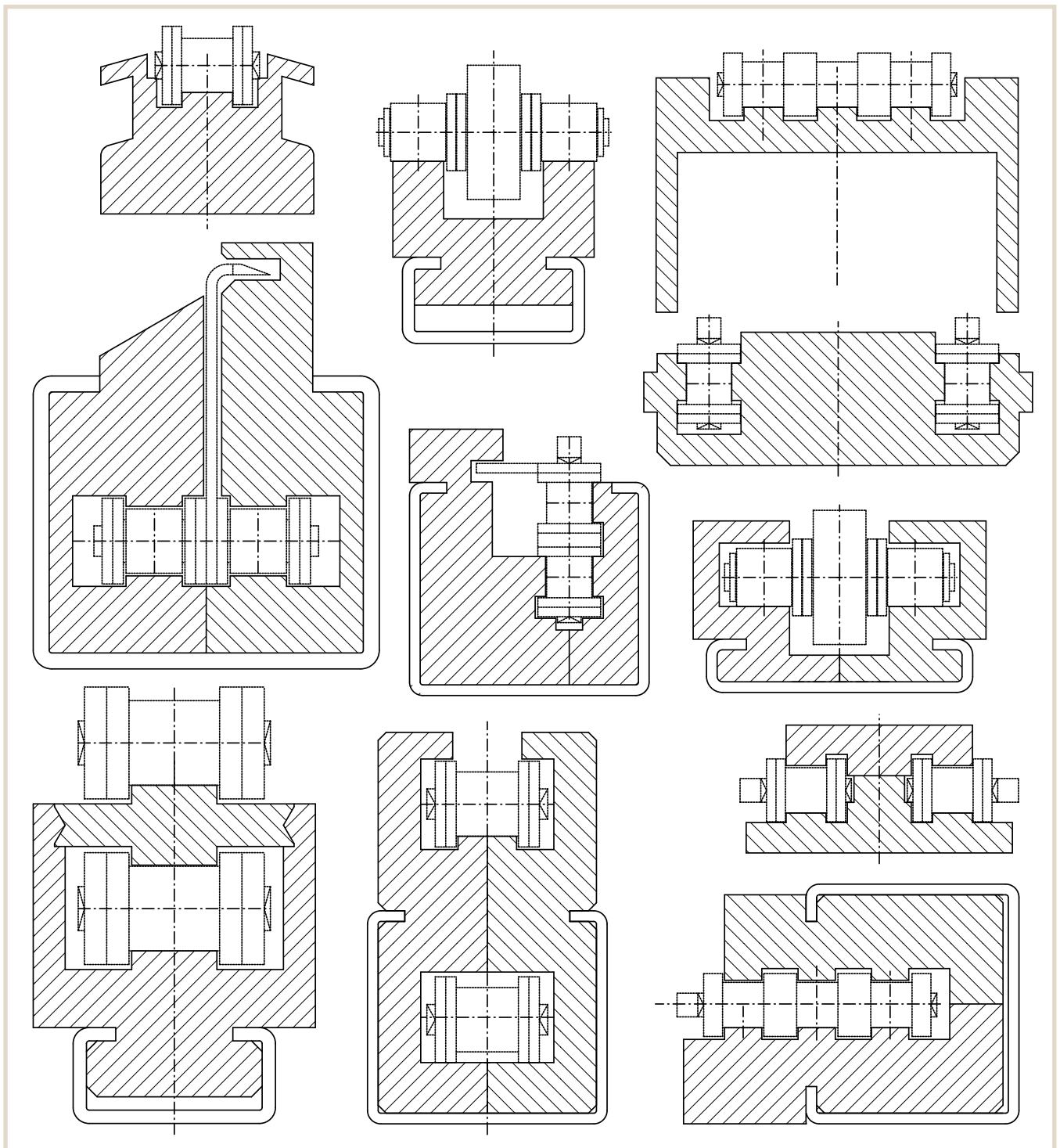

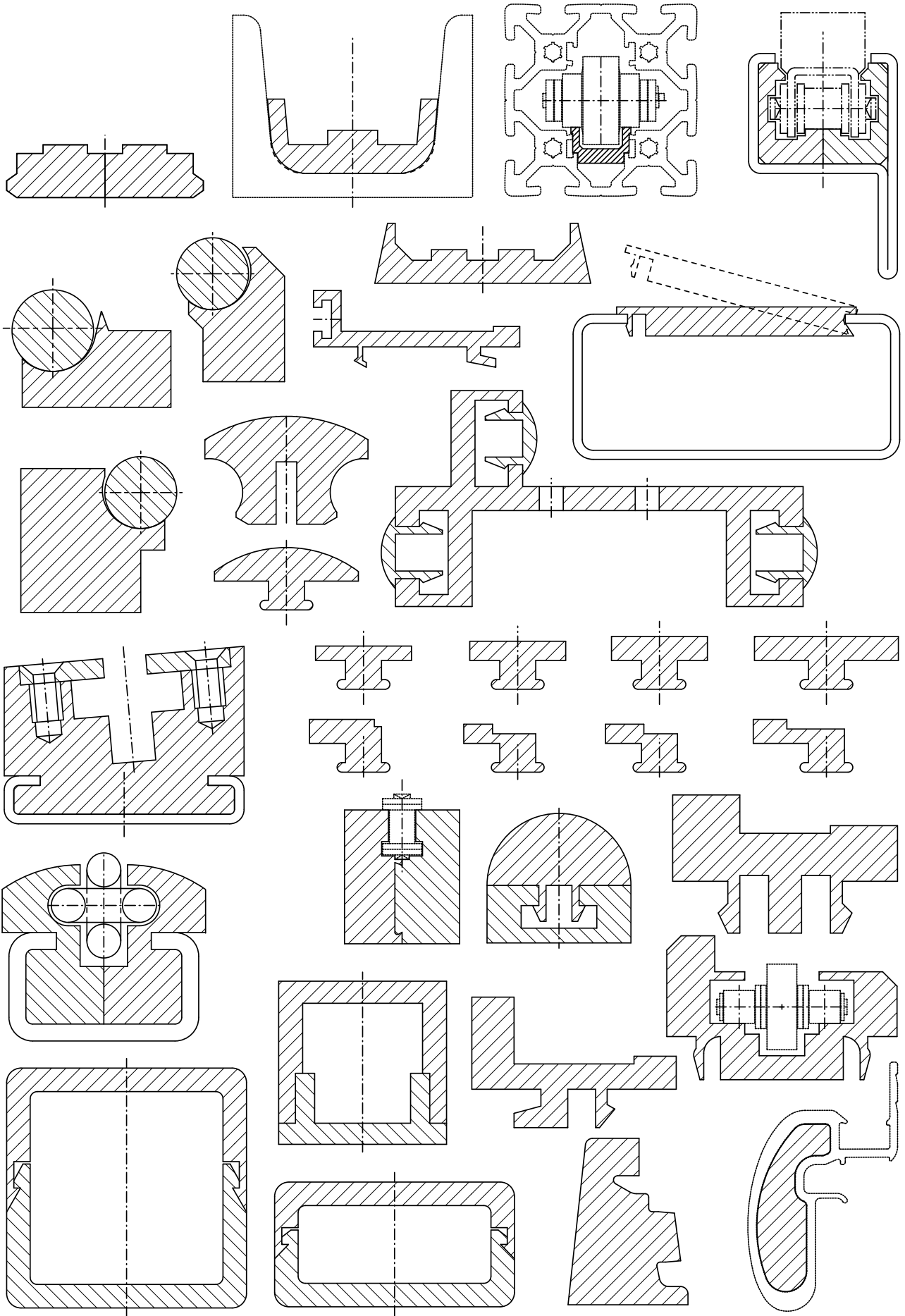

# CHAIN, BELT, AND SLIDING GUIDES

## Chain guides

Where there is friction, there is wear. This is especially the case for applications where metallic materials are used. For example, for chains that run on metal guides, regular lubrication is absolutely vital. The aim is to achieve quiet, smooth running and long-term functional reliability.

Murtfeldt chain guides protect your chains. They guarantee optimum running properties at the same time as extremely high wear resistance. The tried-and-tested Material "S"<sup>®</sup> and the economical alternative "S"<sup>®</sup>1000 have ideal material properties that make them well-suited for use as guides for roller and round link chains.

## Stock and individual production

Our warehouse stocks an extensive range of guides for roller chains that comply with DIN 8187 and round link chains that comply with DIN 766 and DIN 764.

In addition, we can manufacture economical and reliable special guides in accordance with your specifications – even in small lot sizes.

## Advantages of Murtfeldt chain guides

- High wear resistance
- Very good slide properties
- Self-lubricating (no need for any oil lubrication at all)
- Extremely impact and break resistant, even at very low temperatures (up to -250°C)
- High chemical resistance
- Vibration-reducing properties
- No moisture absorption
- No corrosion
- Approved for use in the food industry – EU and FDA (Original Material "S"<sup>®</sup> [FS])

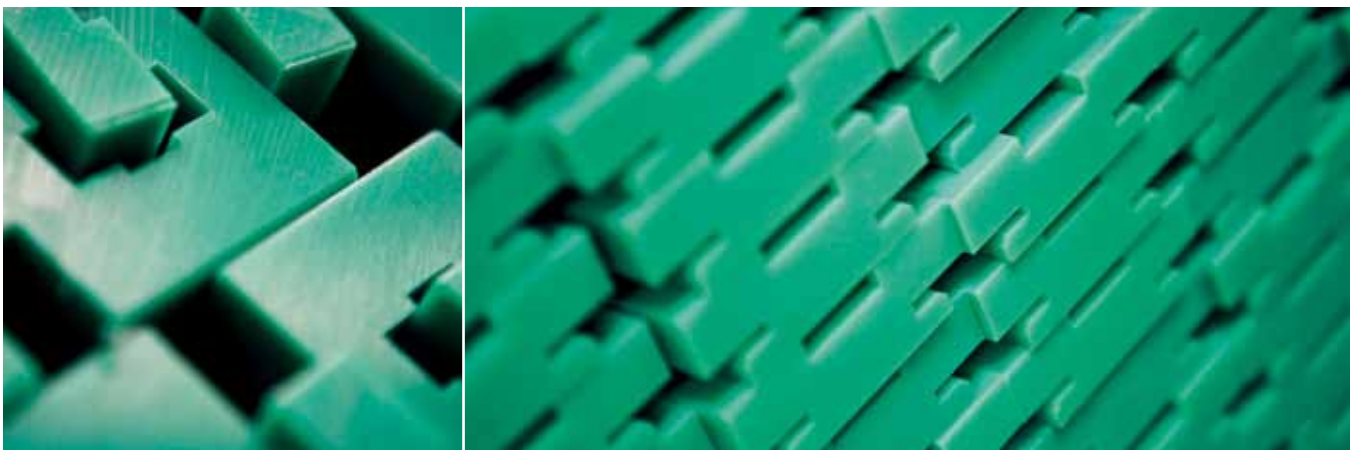

## CONSTRUCTION WITH PLASTIC GUIDES

Construction using thermoplastics requires careful consideration beforehand. The conditions of use have a direct influence on the material selection and design of the plastic guides. You should answer the following questions in advance:

- 
- To what static and dynamic loads will the guide be exposed?

---

  - To what environmental factors, such as chemicals, hot or cold water, steam, or contaminants will the material be exposed?

---

  - Will there be direct contact with foods?

---

  - How high is the working temperature?

---

  - How is the guide to be attached to a C profile (screwed on or inserted)?

---

In comparison with metallic materials, thermoplastics have a higher coefficient of linear thermal expansion.

### Calculation

When calculating the expansion, the anticipated difference between the assembly and minimum and maximum working temperatures is to be taken into account. The coefficient of linear thermal expansion of the material is used to precisely calculate the maximum elongation when the temperature rises and the reduction when the temperature drops (see formula below). The required movement space for the material can thus be taken into account before installation takes place. There are different fastening options depending on the application.

#### Formula for calculating elongation

$$\Delta L = L \times \alpha \times \Delta T$$

$\Delta L$  = Elongation

$L$  = Initial length

$\alpha$  = Coefficient of linear thermal expansion

$\Delta T$  = Temperature difference in °C



# STEEL C PROFILES

Regardless of the fastening method chosen, you should design your plant so that the material can expand. The easiest and most efficient fastening method is to fasten the guide using our steel C profiles. Unlike metals, thermoplastics are particularly predisposed to an increase/reduction in length when temperature variations occur. Mounting a guide in a steel C profile makes sense because of the freedom of movement afforded to the slide bar. This method also makes it easy to replace plastic guides. Steel C profiles also act as stable fasteners and can be welded or screwed on as required. We recommend the use of DIN screws or special assembly using T-head bolts (see page 66). We also offer fixing of steel C profiles with stud welding bolts.

## AVAILABLE VARIANTS

- Galvanized (Stocked)
- Stainless steel (Stocked)
- Untreated/nongalvanized (upon request)

## The advantages of Murtfeldt steel C profiles

- Simple assembly/disassembly of the guide system
- Quick replacement procedure if wear occurs
- Plastic profiles only need to be secured against being pushed out once
- Simple alignment of the guide system
- No distortion occurs when mounting the steel C profile if screws are used
- Guide can increase/decrease in length if temperature variations occur

## Single or varying chain/belt/cargo direction

When expansion takes place, the plastic guide moves up in the opposite direction to the running/conveying direction. You should therefore make sure that sufficient space for the anticipated expansion is provided at the start of the plastic guide.

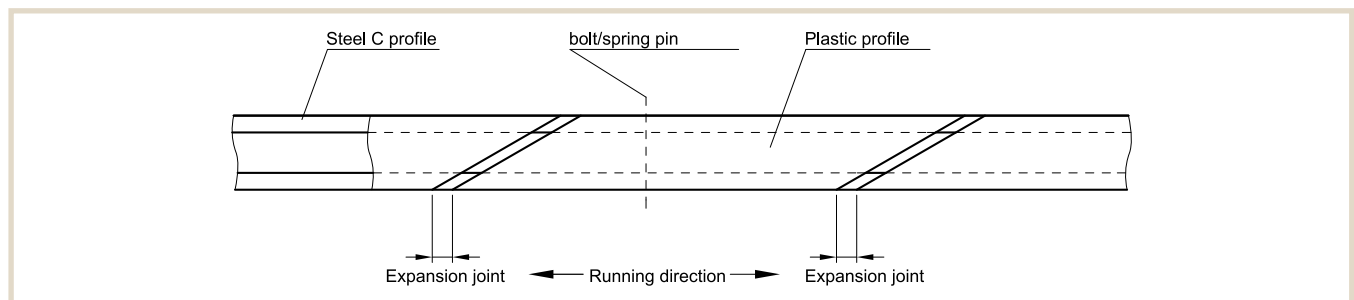
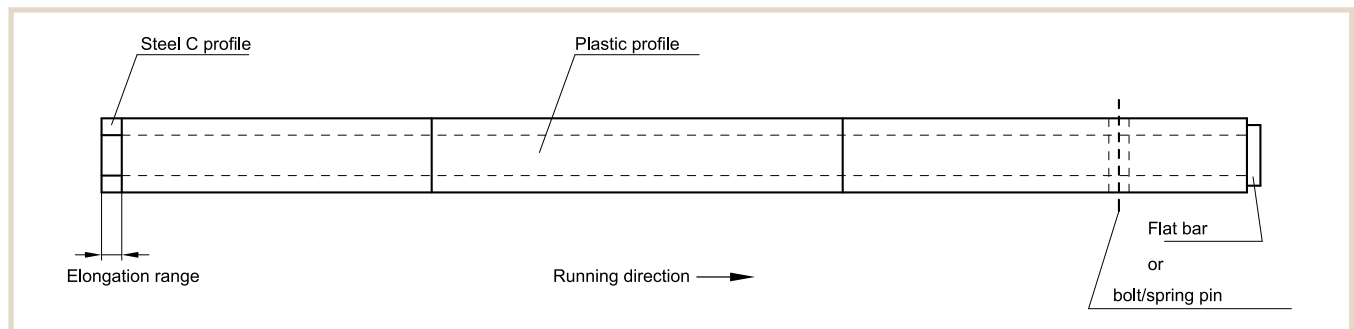



# SELECTION TABLE

Galvanized, untreated/nongalvanized or stainless steel C profiles

Profile No.	B	H	b	s	L	Length	Article no. galvanized	Article no. stainless steel	Article no. nongalvanized
C1	24	5.2	17.5	1	-	2000	351 020 001	351 020 101	
						3000	351 030 001	351 030 101	
						6000	351 060 001	351 060 101	
C3	20	10	10	1.5	-	2000	351 020 003	351 020 103	
						3000	351 030 003	351 030 103	
						6000	351 060 003	351 060 103	351 060 203
C4	50	10	35	2	-	2000	351 020 004	351 020 104	
						6000	351 060 004	351 060 104	
C5	28	12	14	2	-	2000	351 020 005	351 020 105	
						3000	351 030 005	351 030 105	
						6000	351 060 005	351 060 105	351 060 205
C6	80	10	65	2	-	2000	351 020 006	351 020 106	
						6000	351 060 006	351 060 106	
C7	28	16	14	2.5	-	2000	351 020 007	351 020 107	
						6000	351 060 007	351 060 107	351 060 207
C9	38	18	22	2.5	-	2000	351 020 009	351 020 109	
						3000	351 030 009	351 030 109	
						6000	351 060 009	351 060 109	351 060 209
C10	30	24	20	1.5	-	2000	351 020 010	351 020 110	
						6000	351 060 010	351 060 110	351 060 210
C11	45	40	31	2	-	2000	351 020 011	351 020 111	
						6000	351 060 011	351 060 111	351 060 211
C12	60	20	36	2.5	-	2000	351 020 012	351 020 112	
						6000	351 060 012	351 060 112	
C13	65	55	40	3	-	2000	351 020 013	351 020 113	
						6000	351 060 013	351 060 113	
C14 H	31	25	20	2	47	2000	351 020 014	351 020 114	
						3000	351 030 014	351 030 114	
						6000	351 060 014	351 060 114	
C15 V	31	25	20	2	53	2000	351 020 015	351 020 115	
						3000	351 030 015	351 030 115	
						6000	351 060 015	351 060 115	

Dimensions in mm

## C 14H and C 15V steel profiles with punch hole in mounting rail

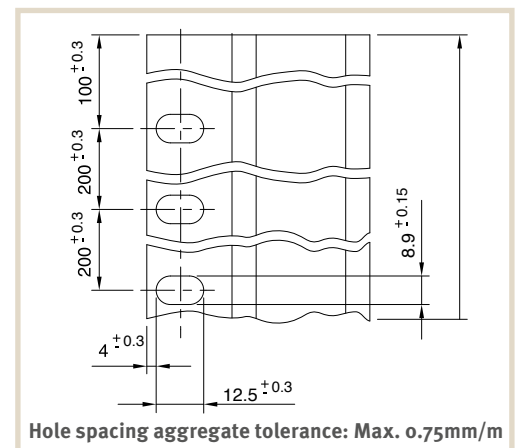
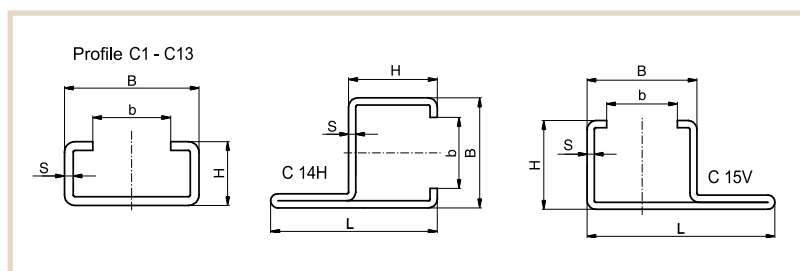

# FASTENING OF STEEL C PROFILES

## With T-head bolts

T-head bolts provide a secure connection between your machine element and our C profiles. As a rule, a simplex connection is used. Duplex connections are available if desired. Our application technology department will be glad to advise you to ensure that you obtain the best implementation for your requirements.

We can bore or punch individual hole patterns if you provide us with an appropriate drawing. For T-head bolt dimensions, see the following page.

---

■ Milled groove for bolt head prevents simultaneous turning of T-head bolt

---

■ Fastening of screw nuts from below (with T-head bolts)

---

■ Punching and boring of required hole pattern in accordance with individual drawings

---

### One-track fastening (standard)

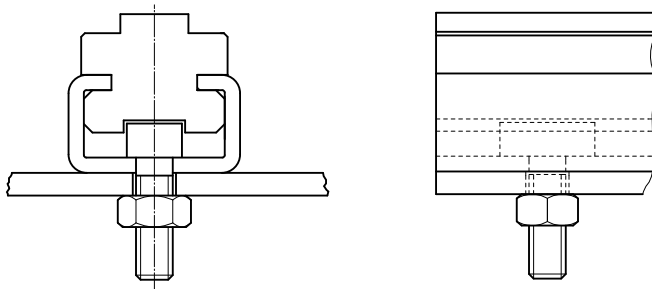

### Two-track fastening

(optional for wide C6 and C12 profiles)

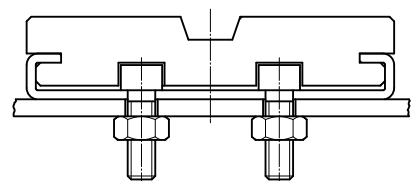

# T-HEAD BOLTS

Galvanized/stainless steel

Thread (M x L)	Suitable for these steel C profiles	A in mm	B in mm	h in mm	Material	Article no.	Type
M6x20	C1, C3, C4, C5, C6, C7, C9, C10, C11, C12, C13	18.0	9.5	4	galvanized	352010001	-
M6x20	C1, C4, C5, C6, C7, C9, C12	15.5	9.0	6	galvanized	352010005	20/12
M6x30	C1, C4, C5, C6, C7, C9, C12	15.5	9.0	6	galvanized	352010003	20/12
M6x40	C1, C4, C5, C6, C7, C9, C12	15.5	9.0	6	galvanized	352010004	20/12
M8x20	C4, C6, C7, C9, C12	15.5	9.0	6	galvanized	352010008	20/12
M8x30	C4, C6, C7, C9, C12	15.5	9.0	6	galvanized	352010006	20/12
M8x40	C4, C6, C7, C9, C12	15.5	9.0	6	galvanized	352010007	20/12
M8x20	C4, C6, C7, C9, C12	23.0	11.0	6	galvanized	352010011	28/15
M8x30	C4, C6, C7, C9, C12	23.0	11.0	6	galvanized	352010019	28/15
M8x40	C4, C6, C7, C9, C12	23.0	11.0	6	galvanized	352010014	28/15
M10x20	C4, C6, C7, C9, C11, C12, C13	23.0	11.0	7	galvanized	352010020	28/15
M10x30	C4, C6, C7, C9, C11, C12, C13	23.0	11.0	7	galvanized	352010012	28/15
M10x40	C4, C6, C7, C9, C11, C12, C13	23.0	11.0	7	galvanized	352010013	28/15
M10x20	C6, C9, C12	31.0	13.5	9	galvanized	352010015	38/17
M10x30	C6, C9, C12	31.0	13.5	9	galvanized	352010016	38/17
M12x40	C6, C11, C12, C13	31.0	13.5	9	galvanized	352010017	38/17
M6x20	C1, C3, C4, C5, C6, C7, C9, C10, C11, C12, C13	18.0	9.5	4	stainless steel	352010002	-
M8x20	C4, C6, C7, C9, C12	15.5	9.0	6	stainless steel	352010025	20/12
M8x30	C4, C6, C7, C9, C12	15.5	9.0	6	stainless steel	352010026	20/12

Please speak with our application technology department to determine the best T-head screw for your needs. We can provide the appropriate models including nuts for one-track and two-track connections.

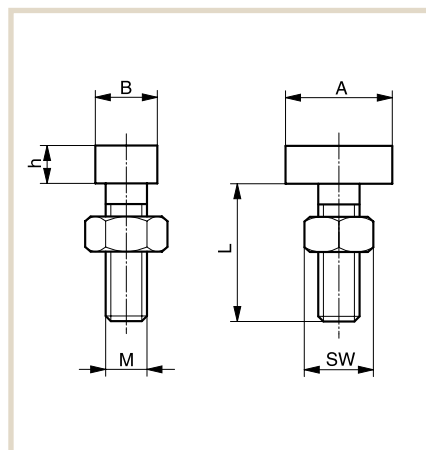

# FIXING THE STEEL C-PROFILE WITH STUD WELDING BOLTS TECHNOLOGY



- Individual fixing of the welded bolt to your specification at any position on the steel-C-profile
- Cost-effective process as no need for complex preparatory work
- Available for galvanized and stainless steel profiles
- Threaded bolts up to M8
- Max. bolt length 40 mm

Thread size	Length	Material
M4	12	stainless steel
M5	8	stainless steel
M5	20	stainless steel
M5	20	steel
M6	25	stainless steel
M6	25	steel
M8	15	stainless steel
M8	15	steel
M8	20	stainless steel
M8	20	steel
M8	30	stainless steel
M8	30	steel

Other dimensions on request.

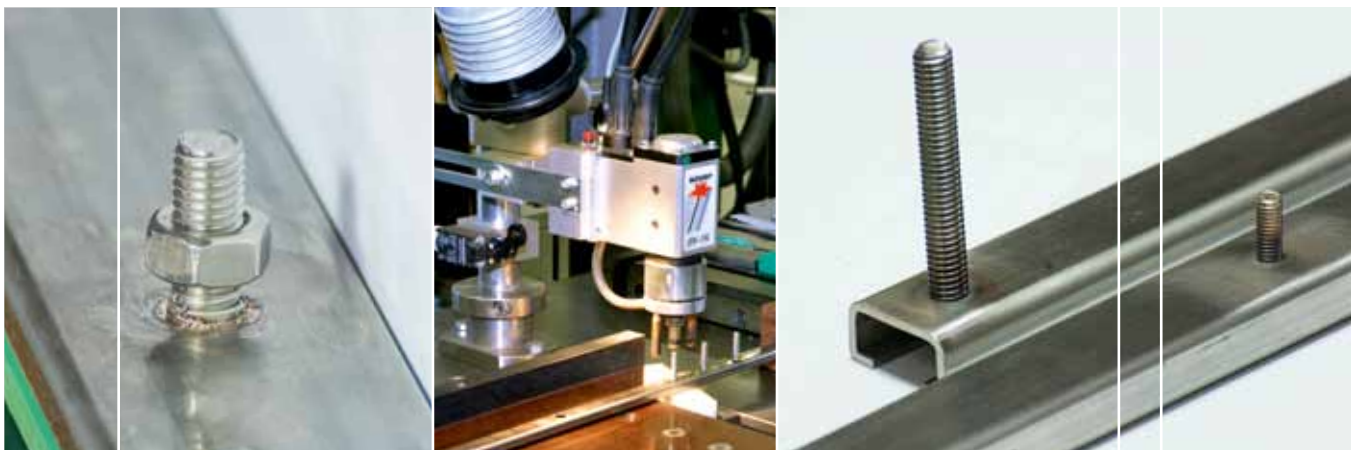

# Chain Guides for Roller Chains as per DIN 8187

## TYPE T



DIN 8187 chain no.	Chain dimensions in inches	B	H	b	h	Article no.
06B-1	3/8" x 7/32"	15	10	5,4	1,5	221 010 002
083-1	1/2" x 3/16"	15	10	4,5	1,5	221 010 003
085-1	1/2" x 1/4"	20	10	6,2	2,2	221 010 004
08B-1	1/2" x 5/16"	20	10	7,4	2,2	221 010 005
08B-1	1/2" x 5/16"	20	15	7,4	2,2	221 010 006
08B-1	1/2" x 5/16"	20	20	7,4	2,2	221 010 007
08B-1	1/2" x 5/16"	20	30	7,4	2,2	221 010 008
-	5/8" x 1/4"	20	10	6,2	2,6	221 010 009
10B-1	5/8" x 3/8"	20	10	9,3	2,6	221 010 010
10B-1	5/8" x 3/8"	20	15	9,3	2,6	221 010 011
10B-1	5/8" x 3/8"	20	20	9,3	2,6	221 010 012
10B-1	5/8" x 3/8"	20	30	9,3	2,6	221 010 013
12B-1	3/4" x 7/16"	25	10	11,3	2,4	221 010 014
12B-1	3/4" x 7/16"	25	15	11,3	2,4	221 010 015
12B-1	3/4" x 7/16"	25	20	11,3	2,4	221 010 016
12B-1	3/4" x 7/16"	25	30	11,3	2,4	221 010 017
16B-1	1" x 17 mm	40	15	16,0	3,5	221 010 018
16B-1	1" x 17 mm	40	20	16,0	3,5	221 010 019
16B-1	1" x 17 mm	40	30	16,0	3,5	221 010 020
20B-1	1 1/4" x 3/4"	45	15	18,0	4,2	221 010 021
24B-1	1 1/2" x 1"	60	15	24,0	5,5	221 010 022
28B-1	1 3/4" x 31 mm	75	20	30,0	6,8	221 010 023
32B-1	2" x 31 mm	80	20	30,0	7,7	221 010 024

Dimensions in mm - Separate ASA/JIS product catalogue available.

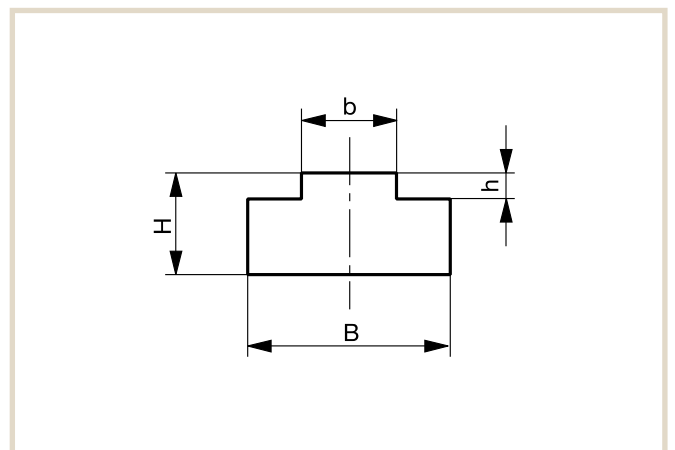

# TYPE CT



DIN 8187 chain no.	Chain dimensions in inches	C profile type	B1	B2	H	Hc	b	h	Article no.
06B-1	3/8" x 7/32"	C3	17	20	14	17	5.4	1.5	221 210 015 351 020 003
083-1	1/2" x 3/16"	C3	17	20	14	17	4.5	1.5	221 210 002 351 020 003
085-1	1/2" x 1/4"	C3	17	20	14	17	6.2	2.2	221 210 003 351 020 003
08B-1	1/2" x 5/16"	C1	20	24	10	11	7.4	2.2	221 210 001 351 020 001
08B-1	1/2" x 5/16"	C3	17	20	14	17	7.4	2.2	221 210 004 351 020 003
-	5/8" x 1/4"	C3	17	20	14	17	6.2	2.6	221 210 005 351 020 003
10B-1	5/8" x 3/8"	C3	17	20	14	17	9.3	2.6	221 210 006 351 020 003
12B-1	3/4" x 7/16"	C3	20	20	14	17	11.3	2.4	221 210 007 351 020 003
12B-1	3/4" x 7/16"	C5	24	28	14	18	11.3	2.4	221 210 008 351 020 005
16B-1	1" x 17 mm	C5	24	28	14	18	16	3.5	221 210 009 351 020 005
20B-1	1 1/4" x 3/4"	C5	28	28	14	18	18	4.2	221 210 010 351 020 005
24B-1	1 1/2" x 1"	C9	33	38	23	30	24	5.5	221 210 011 351 020 009
28B-1	1 3/4" x 31 mm	C9	38	38	23	30	30	6.8	221 210 012 351 020 009
32B-1	2" x 31 mm	C9	38	38	23	30	30	7.7	221 210 013 351 020 009
32B-1	2" x 31 mm	C12	60	60	25	35	30	7.7	221 210 014 351 020 012

Dimensions in mm · Separate ASA/JIS product catalogue available.

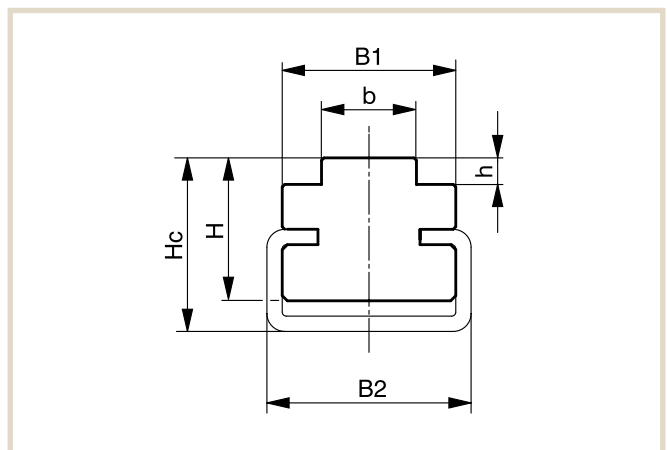

# TYPE T-DUPLEX



DIN 8187 chain no.	Chain dimensions in inches	B	H	b	h	e+b	Article no.
06B-2	3/8" x 7/32"	25.0	10	5.3	1.5	15.6	221 010 025
08B-2	1/2" x 5/16"	35.0	10	7.2	2.2	21.2	221 010 026
08B-2	1/2" x 5/16"	35.0	15	7.2	2.2	21.2	221 010 027
08B-2	1/2" x 5/16"	35.0	20	7.2	2.2	21.2	221 010 028
08B-2	1/2" x 5/16"	35.0	30	7.2	2.2	21.2	221 010 029
10B-2	5/8" x 3/8"	40.0	10	9.0	2.6	25.6	221 010 030
12B-2	3/4" x 7/16"	45.0	15	10.9	2.4	30.4	221 010 031
12B-2	3/4" x 7/16"	45.0	10	10.9	2.4	30.4	221 010 032
16B-2	1" x 17 mm	47.8	15	15.8	3.5	47.8	221 010 033
20B-2	1 1/4" x 3/4"	54.7	15	18.2	4.2	54.7	221 010 034
24B-2	1 1/2" x 1"	72.0	20	23.6	5.5	72.0	221 010 035
28B-2	1 3/4" x 31 mm	88.4	25	28.8	6.8	88.4	221 010 036
32B-2	2" x 31 mm	87.4	30	28.8	7.7	87.4	221 010 037

Dimensions in mm - Separate ASA/JIS product catalogue available.

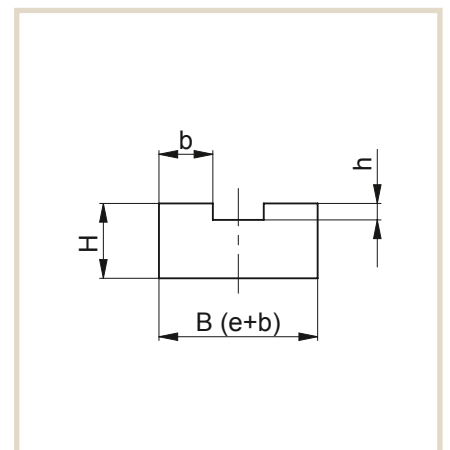
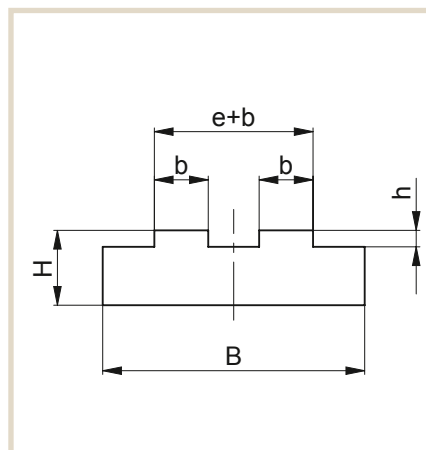

# TYPE CT-DUPLEX



DIN 8187 chain no.	Chain dimensions in inches	C profile type 	B1	B2	H	Hc	b	h	Article no.
06B-2	3/8" x 7/32"	C3	15.6	20	14	17	5.3	1.5	221 210 022 351 020 003
08B-2	1/2" x 5/16"	C3	21.2	20	14	17	7.2	2.2	221 210 016 351 020 003
10B-2	5/8" x 3/8"	C3	25.6	20	14	17	9.0	2.6	221 210 017 351 020 003
12B-2	3/4" x 7/16"	C5	30.4	28	15	20	10.9	2.4	221 210 018 351 020 005
16B-2	1" x 17 mm	C9	47.8	38	20	27	15.8	3.5	221 210 019 351 020 009
20B-2	1 1/4" x 3/4"	C12	54.7	60	22	30	18.2	4.2	221 210 020 351 020 012
24B-2	1 1/2" x 1"	C12	72.0	60	25	35	23.6	5.5	221 210 021 351 020 012

Dimensions in mm - Separate ASA/JIS product catalogue available.

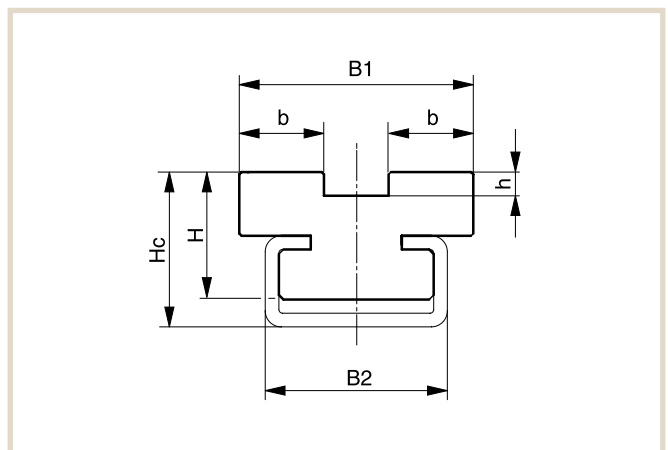
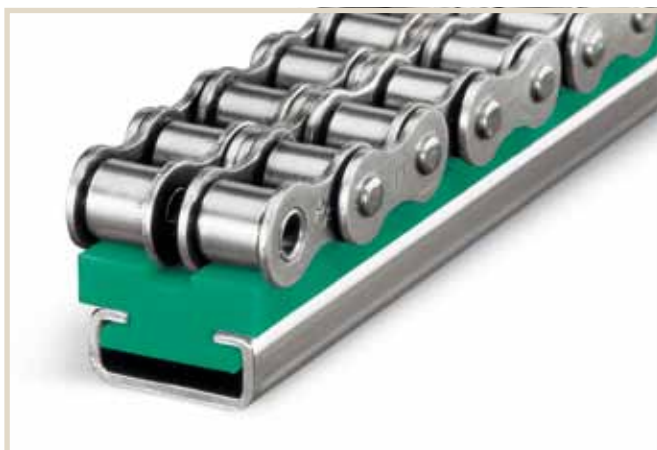



# TYPE T-TRIPLEX



DIN 8187 chain no.	Chain dimensions in inches	B	H	b	h	2e+b	Article no.
06B-3	3/8" x 7/32"	35.0	10	5.3	1.5	25.9	221 010 038
08B-3	1/2" x 5/16"	45.0	10	7.1	2.2	34.9	221 010 039
10B-3	5/8" x 3/8"	55.0	10	8.9	2.6	42.1	221 010 040
12B-3	3/4" x 7/16"	60.0	15	10.7	2.4	49.7	221 010 041
16B-3	1" x 17 mm	79.5	20	15.7	3.5	79.5	221 010 042
20B-3	1 1/4" x 3/4"	91.0	20	18.0	4.2	91.0	221 010 043
24B-3	1 1/2" x 1"	120.0	25	23.4	5.5	120.0	221 010 044

Dimensions in mm - Separate ASA/JIS product catalogue available.

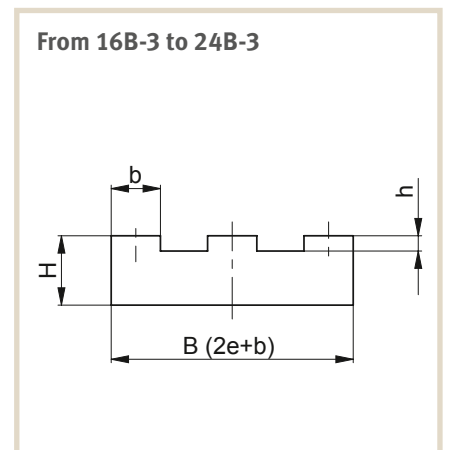
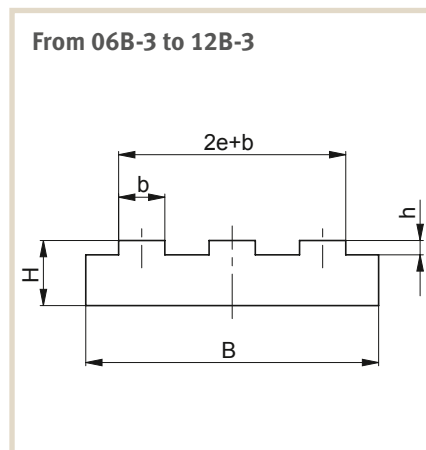

# TYPE CT-TRIPLEX



DIN 8187 chain no.	Chain dimensions in inches	C profile type 	B1	B2	H	Hc	b	h	2e + b	Article no.
06B-3	3/8" x 7/32"		30.0		15	20	5.3	1.5	25.9	221 210 023
		C5		28						351 020 005
08B-3	1/2" x 5/16"		34.9		15	20	7.1	2.2	34.9	221 210 024
		C5		28						351 020 005
10B-3	5/8" x 3/8"		50.0		15	17	8.9	2.6	42.1	221 210 025
		C4		50						351 020 004
12B-3	3/4" x 7/16"		49.7		18	20	10.7	2.4	49.7	221 210 026
		C4		50						351 020 004
16B-3	1" x 17 mm		79.5		20	22	15.7	3.5	79.5	221 210 027
		C6		80						351 020 006
20B-3	1 1/4" x 3/4"		91.0		20	22	18.0	4.2	91.0	221 210 028
		C6		80						351 020 006

Dimensions in mm - Separate ASA/JIS product catalogue available.

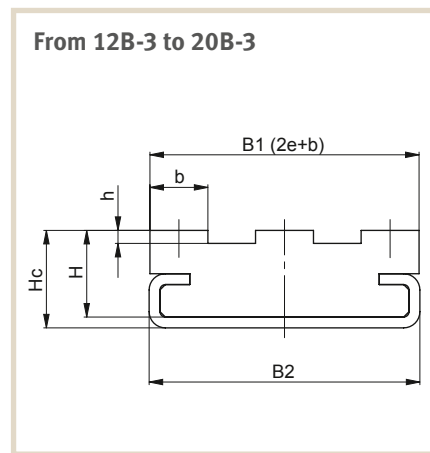
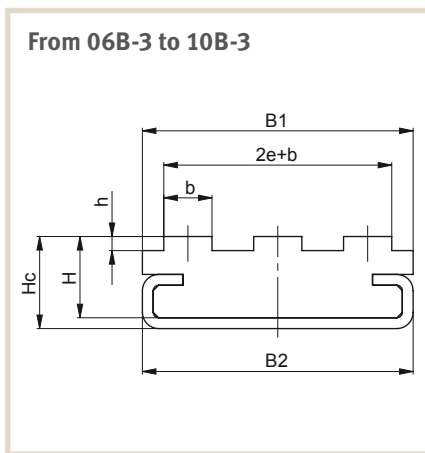
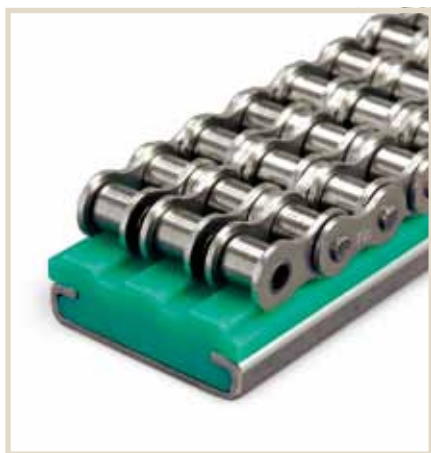

# TYPE TU



DIN 8187 chain no.	Chain dimensions in inches	B	H	b	h	Article no.
-	3/8" x 5/32"	15	10	12	2.2	221 110 010
083-1	1/2" x 3/16"	15	10	12	2.2	221 110 011

Dimensions in mm · Separate ASA/JIS product catalogue available.

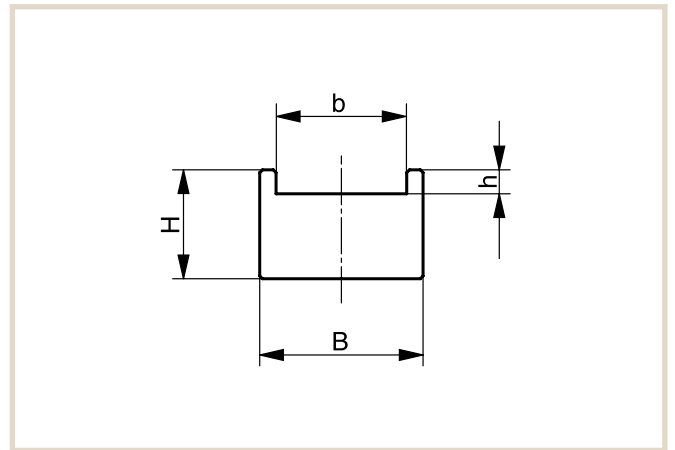

# TYPE CTU



DIN 8187 chain no.	Chain dimensions in inches	C profile type	B1	B2	H	Hc	b	h	Article no.
-	3/8" x 5/32"	C3	17	20	14	17	12	2.2	221 310 010
									351 020 003
083-1	1/2" x 3/16"	C3	17	20	14	17	12	2.2	221 310 010
									351 020 003

Dimensions in mm · Separate ASA/JIS product catalogue available.

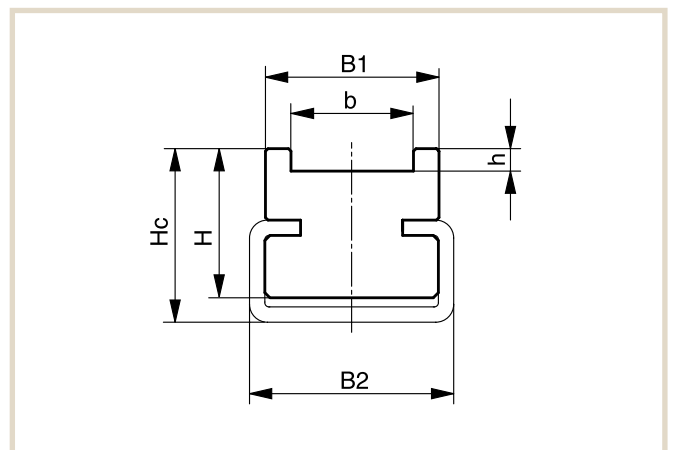

# TYPE TS



DIN 8187 chain no.	Chain dimensions in inches	B	H	b1	b2	h1	h2	Article no.
06B-1	3/8" x 7/32"	20	10	3.8	13.0	1.5	1.1	221 110 001
083-1	1/2" x 3/16"	20	10	3.0	12.4	1.6	1.4	221 110 002
085-1	1/2" x 1/4"	22	10	4.5	15.1	2.2	1.6	221 110 003
08B-1	1/2" x 5/16"	25	15	5.7	16.3	2.2	1.6	221 110 004
-	5/8" x 1/4"	25	15	4.1	16.1	2.6	2.1	221 110 005
10B-1	5/8" x 3/8"	28	15	7.4	19.2	2.6	2.1	221 110 006
12B-1	3/4" x 7/16"	30	20	9.2	21.8	2.4	2.8	221 110 007
16B-1	1" x 17 mm	42	25	15.0	35.0	3.5	3.3	221 110 008
20B-1	1 1/4" x 3/4"	50	25	16.8	40.0	4.2	4.0	221 110 009

Dimensions in mm · Separate ASA/JIS product catalogue available.

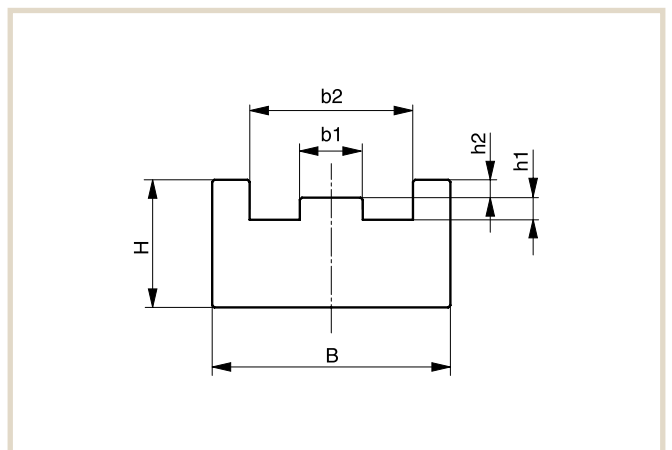

# TYPE CTS



DIN 8187 chain no.	Chain dimensions in inches	C profile type	B1	B2	H	Hc	b1	b2	h1	h2	Article no.
06B-1	3/8" x 7/32"	C3	20	20	14	17	3.8	13.0	1.5	1.1	221 310 001 351 020 003
083-1	1/2" x 3/16"	C3	20	20	14	17	3.0	12.4	1.6	1.4	221 310 002 351 020 003
085-1	1/2" x 1/4"	C3	22	20	14	17	4.5	15.1	2.2	1.6	221 310 003 351 020 003
08B-1	1/2" x 5/16"	C3	25	20	16	20	5.7	16.3	2.2	1.6	221 310 004 351 020 003
-	5/8" x 1/4"	C3	25	20	16	20	4.1	16.1	2.6	2.1	221 310 005 351 020 003
10B-1	5/8" x 3/8"	C5	28	28	16	20	7.4	19.2	2.6	2.1	221 310 006 351 020 005
12B-1	3/4" x 7/16"	C5	30	28	18	22	9.2	21.8	2.4	2.8	221 310 007 351 020 005
16B-1	1" x 17 mm	C9	42	38	25	30	15.0	35.0	3.5	3.3	221 310 008 351 020 009
20B-1	1 1/4" x 3/4"	C9	50	38	30	35	16.8	40.0	4.2	4.0	221 310 009 351 020 009

Dimensions in mm - Separate ASA/JIS product catalogue available.

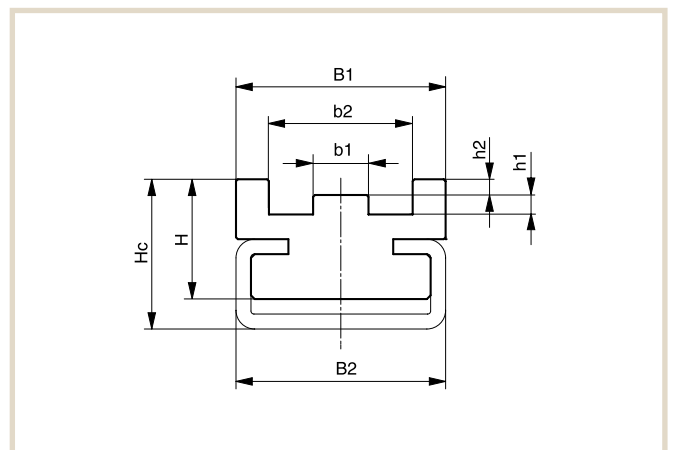

# TYPE U



DIN 8187 chain no.	Chain dimensions in inches	B	H	d <sub>2</sub>	g	h <sub>2</sub>	h <sub>3</sub>	Article no.
-	3/8" x 5/32"	20	15	4	9.4	2.8	4.2	221 110 012
06B-1	3/8" x 7/32"	20	15	4	9.4	2.8	4.2	221 110 013
083-1	1/2" x 3/16"	20	15	5	10.8	2.3	3.8	221 110 014
g=12,8mm	1/2" x 1/4"	25	15	5	12.8	3.5	5.0	221 110 015
08B-1	1/2" x 5/16"	25	15	5	12.8	3.5	5.0	221 110 017
-	5/8" x 1/4"	25	15	6	15.4	3.6	5.2	221 110 016
085-1	1/2 x 1/4"	20	15	5	11.8	3.2	4.7	221 110 018
10B-1	5/8" x 3/8"	25	15	6	15.4	3.6	5.0	221 110 019
12B-1	3/4" x 7/16"	25	20	7	17.0	3.9	5.7	221 110 020
16B-1	1" x 17 mm	33	25	10	24.0	8.4	10.6	221 110 021
20B-1	1 1/4" x 3/4"	55	25	11	28.0	10.0	12.2	221 110 022
24B-1	1 1/2" x 1"	60	30	16	36.6	13.0	16.0	221 110 023
28B-1	1 3/4" x 31 mm	65	30	17	40.0	16.0	18.0	221 110 024
32B-1	2" x 31 mm	70	30	20	44.6	16.0	20.0	221 110 025

Dimensions in mm · Separate ASA/JIS product catalogue available.

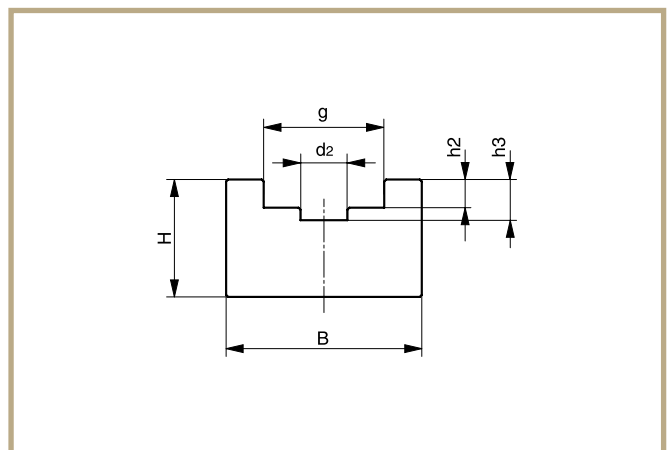

# TYPE CU



DIN 8187 chain no.	Chain dimensions in inches	C profile type 	B1	B2	H	Hc	d2	g	h2	h3	Article no.
-	3/8" x 5/32"	C3	20	20	14	17	4	9.4	2.8	4.2	221 310 011 351 020 003
06B-1	3/8" x 7/32"	C3	20	20	14	17	4	9.4	2.8	4.2	221 310 013 351 020 003
083-1	1/2" x 3/16"	C3	20	20	14	17	5	10.8	2.3	3.8	221 310 015 351 020 003
085-1	1/2" x 1/4"	C5	28	28	14	18	5	11.8	3.2	4.7	221 310 017 351 020 005
g=12,8mm	1/2" x 1/4"	C5	28	28	14	18	5	12.8	3.5	5.0	221 310 019 351 020 005
08B-1	1/2" x 5/16"	C1	20	24	10	11	5	12.8	3.5	5.0	221 310 012 351 020 001
-	5/8" x 1/4"	C5	24	28	12	18	6	15.4	3.6	5.2	221 310 021 351 020 005
10B-1	5/8" x 3/8"	C5	24	28	12	18	6	15.4	3.6	5.0	221 310 014 351 020 005
12B-1	3/4" x 7/16"	C5	24	28	12	18	7	17.0	3.9	5.7	221 310 016 351 020 005
16B-1	1" x 17 mm	C9	33	38	20	30	10	24.0	8.4	10.6	221 310 018 351 020 009
20B-1	1 1/4" x 3/4"	C12	60	60	25	35	11	28.0	10.0	12.2	221 310 020 351 020 012
24B-1	1 1/2" x 1"	C12	60	60	30	40	16	36.6	13.0	16.0	221 310 022 351 020 012
28B-1	1 3/4" x 31 mm	C12	65	60	38	45	17	40.0	16.0	18.0	221 310 023 351 020 012
32B-1	2" x 31 mm	C12	70	60	38	45	20	44.6	16.0	20.0	221 310 024 351 020 012

Dimensions in mm · Separate ASA/JIS product catalogue available.

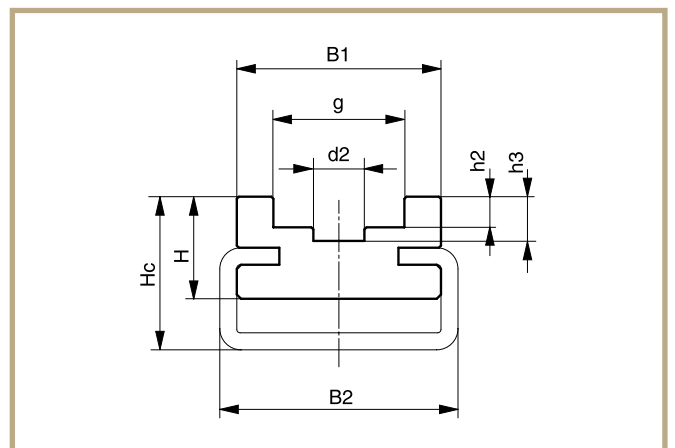

# TYPE K



DIN 8187 chain no.	Chain dimensions in inches	B	H	d1	d2	g	h1	h2	h3	Article no.
-	3/8" x 5/32"	20	25	6.6	4	9.4	3.6	7.0	8.0	221 110 026
06B-1	3/8" x 7/32"	20	25	6.6	4	9.4	5.5	8.9	10.0	221 110 027
083-1	1/2" x 3/16"	20	25	8.0	5	10.8	4.5	8.0	9.5	221 110 028
085-1	1/2" x 1/4"	24	30	8.0	5	11.8	6.2	9.8	11.3	221 110 029
g=12,8mm	1/2" x 1/4"	24	30	8.8	5	12.8	6.2	10.2	11.7	221 110 030
08B-1	1/2" x 5/16"	24	30	8.9	5	12.8	7.4	11.5	13.0	221 110 031
-	5/8" x 1/4"	30	30	10.6	6	15.4	6.2	10.2	11.6	221 110 032
10B-1	5/8" x 3/8"	30	35	10.6	6	15.4	9.3	13.5	14.9	221 110 033
12B-1	3/4" x 7/16"	40	35	12.4	7	17.0	11.3	15.9	17.5	221 110 034
16B-1	1" x 17 mm	40	45	16.4	10	24.0	16.0	25.7	27.7	221 110 035
20B-1	1 1/4" x 3/4"	50	50	20.0	11	28.0	18.0	29.5	31.7	221 110 036
24B-1	1 1/2" x 1"	60	60	27.0	16	36.6	24.0	38.2	41.2	221 110 037
28B-1	1 3/4" x 31 mm	60	70	30.0	17	41.0	30.0	47.0	49.0	221 110 038
32B-1	2" x 31 mm	70	75	31.0	19	44.6	30.0	47.3	50.0	221 110 039

Dimensions in mm - Separate ASA/JIS product catalogue available.

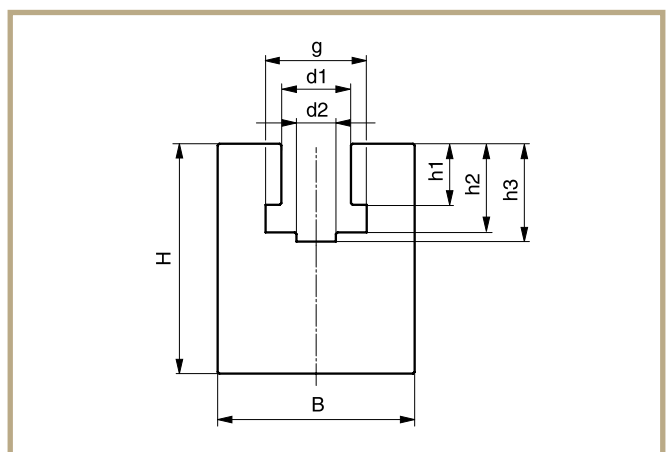



# TYPE CK



DIN 8187 chain no.	Chain dimensions in inches	C profile type	B1	B2	H	Hc	d1	d2	g	h1	h2	h3	Article no.
-	3/8" x 5/32"	C3	20	20	18	21	6.6	4	9.4	3.6	7.0	8.0	221 310 025 351 020 003
06B-1	3/8" x 7/32"	C3	20	20	18	21	6.6	4	9.4	5.5	8.9	10.0	221 310 026 351 020 003
083-1	1/2" x 3/16"	C3	20	20	18	21	8.0	5	10.8	4.5	8.0	9.5	221 310 027 351 020 003
085-1	1/2" x 1/4"	C7	24	28	28	32	8.0	5	11.8	6.2	9.8	11.3	221 310 028 351 020 007
g=12,8mm	1/2" x 1/4"	C7	24	28	28	32	8.8	5	12.8	6.2	10.2	11.7	221 310 029 351 020 007
08B-1	1/2" x 5/16"	C7	24	28	28	32	8.9	5	12.8	7.4	11.5	13.0	221 310 030 351 020 007
-	5/8" x 1/4"	C7	24	28	28	32	10.6	6	15.4	6.2	10.2	11.6	221 310 031 351 020 007
10B-1	5/8" x 3/8"	C7	24	28	28	32	10.6	6	15.4	9.3	13.5	14.9	221 310 032 351 020 007
12B-1	3/4" x 7/16"	C9	32	38	35	43	12.4	7	17.0	11.3	15.9	17.5	221 310 033 351 020 009
16B-1	1" x 17 mm	C9	40	38	45	50	16.4	10	24.0	16.0	25.7	27.7	221 310 034 351 020 009
20B-1	1 1/4" x 3/4"	C12	60	60	50	55	20.0	11	28.0	18.0	29.5	31.7	221 310 035 351 020 012
24B-1	1 1/2" x 1"	C12	60	60	60	65	27.0	16	36.6	24.0	38.2	41.2	221 310 036 351 020 012
28B-1	1 3/4" x 31 mm	C12	70	60	75	80	30.0	17	40.0	30.0	47.0	49.0	221 310 037 351 020 012
32B-1	2" x 31 mm	C12	70	60	75	80	31.0	19	44.6	30.0	47.3	50.0	221 310 038 351 020 012

Dimensions in mm - Separate ASA/JIS product catalogue available.

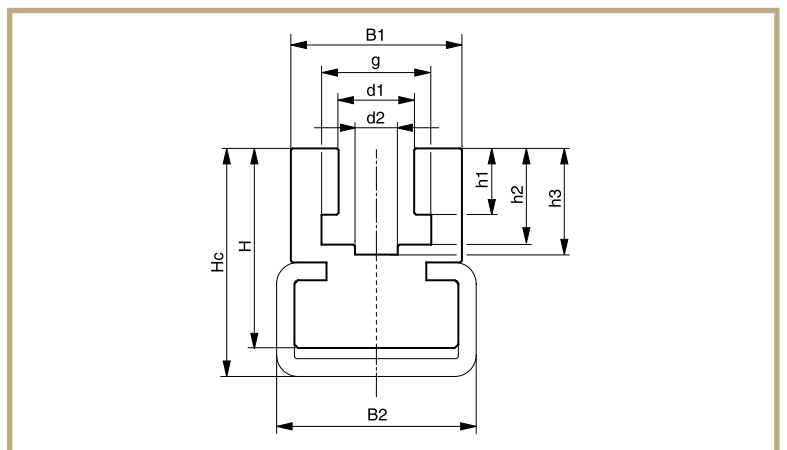

# TYPE CKG



DIN 8187 chain no.	Chain dimensions in inches	C profile type 	B	Hc	d1	d2	g	h1	h2	h3	Article no.
-	3/8" x 5/32"	C10	30	24	6.6	4	9.4	3.6	7.0	8.0	221 410 001 351 020 010
06B-1	3/8" x 7/32"	C10	30	24	6.6	4	9.4	5.5	8.9	10.0	221 410 002 351 020 010
083-1	1/2" x 3/16"	C10	30	24	8.0	5	10.8	4.5	8.0	9.5	221 410 003 351 020 010
085-1	1/2" x 1/4"	C10	30	24	8.0	5	11.8	6.2	9.8	11.3	221 410 020 351 020 010
g=12,8mm	1/2" x 1/4"	C10	30	24	8.8	5	12.8	6.2	10.2	11.7	221 410 021 351 020 010
08B-1	1/2" x 5/16"	C10	30	24	8.9	5	12.8	7.4	11.5	13.0	221 410 004 351 020 010
-	5/8" x 1/4"	C10	30	24	10.6	6	15.4	6.2	10.2	11.6	221 410 022 351 020 010
10B-1	5/8" x 3/8"	C10	30	24	10.6	6	15.4	9.3	13.5	14.9	221 410 005 351 020 010
12B-1	3/4" x 7/16"	C10	30	24	12.4	7	17.0	11.3	15.9	17.5	221 410 006 351 020 010
16B-1	1" x 17 mm	C11	45	40	16.4	10	24.0	16.0	25.7	27.7	221 410 007 351 020 011
20B-1	1 1/4" x 3/4"	C11	45	40	20.0	11	28.0	18.0	29.5	31.7	221 410 008 351 020 011
24B-1	1 1/2" x 1"	C13	65	55	27.0	16	36.6	24.0	38.2	41.2	221 410 009 351 020 013
28B-1	1 3/4" x 31 mm	C13	65	60	30.0	17	41.0	30.0	47.0	49.0	221 410 010 351 020 013
32B-1	2" x 31 mm	C13	65	60	31.0	19	44.6	30.0	47.3	50.0	221 410 011 351 020 013

Dimensions in mm - Separate ASA/JIS product catalogue available.

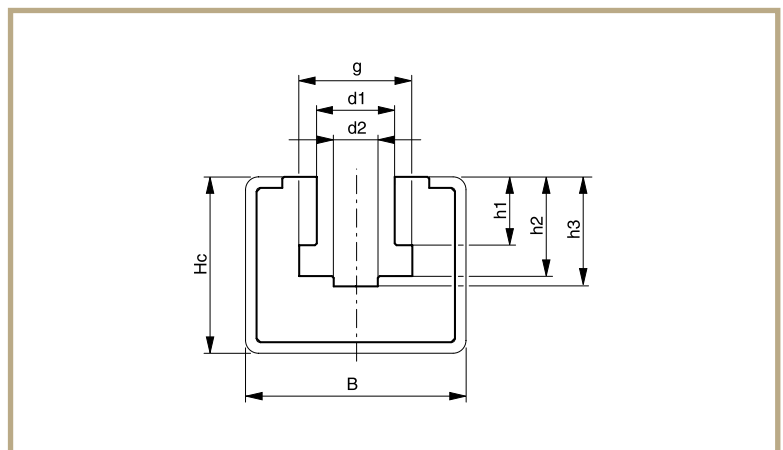

# TYPE CKG 14 H



DIN 8187 chain no.	Chain dimensions in inches	C profile type 	B	Hc	L	d1	d2	g	h1	h2	h3	Article no.
-	3/8" x 5/32"	C14H	31	25	47	6.6	4	9.4	3.6	7.0	8.0	221 410 001 351 020 014
06B-1	3/8" x 7/32"	C14H	31	25	47	6.6	4	9.4	5.5	8.9	10.0	221 410 002 351 020 014
083-1	1/2" x 3/16"	C14H	31	25	47	8.0	5	10.8	4.5	8.0	9.5	221 410 003 351 020 014
085-1	1/2" x 1/4"	C14H	31	25	47	8.0	5	11.8	6.2	9.8	11.3	221 410 020 351 020 014
g=12,8mm	1/2" x 1/4"	C14H	31	25	47	8.8	5	12.8	6.2	10.2	11.7	221 410 021 351 020 014
08B-1	1/2" x 5/16"	C14H	31	25	47	8.9	5	12.8	7.4	11.5	13.0	221 410 004 351 020 014
-	5/8" x 1/4"	C14H	31	25	47	10.6	6	15.4	6.2	10.2	11.6	221 410 022 351 020 014
10B-1	5/8" x 3/8"	C14H	31	25	47	10.6	6	15.4	9.3	13.5	14.9	221 410 005 351 020 014
12B-1	3/4" x 7/16"	C14H	31	25	47	12.4	7	17.0	11.3	15.9	17.5	221 410 006 351 020 014

Dimensions in mm · Separate ASA/JIS product catalogue available.

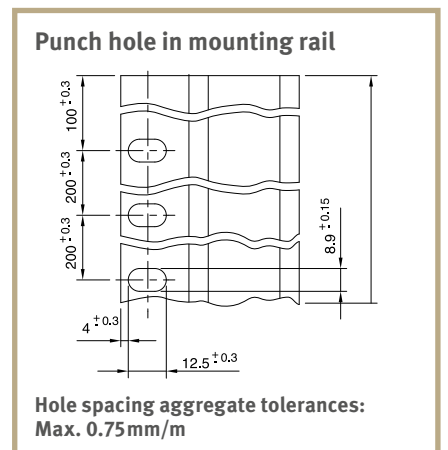
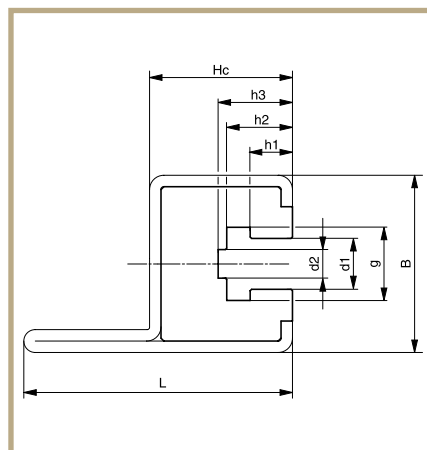

# TYPE CKG 15 V



DIN 8187 chain no.	Chain dimensions in inches	C profile type	B	Hc	L	d1	d2	g	h1	h2	h3	Article no.
-	3/8" x 5/32"	C15V	31	25	53	6.6	4	9.4	3.6	7.0	8.0	221 410 001 351 020 015
06B-1	3/8" x 7/32"	C15V	31	25	53	6.6	4	9.4	5.5	8.9	10.0	221 410 002 351 020 015
083-1	1/2" x 3/16"	C15V	31	25	53	8.0	5	10.8	4.5	8.0	9.5	221 410 003 351 020 015
085-1	1/2" x 1/4"	C15V	31	25	53	8.0	5	11.8	6.2	9.8	11.3	221 410 020 351 020 015
g=12,8mm	1/2" x 1/4"	C15V	31	25	53	8.8	5	12.8	6.2	10.2	11.7	221 410 021 351 020 015
08B-1	1/2" x 5/16"	C15V	31	25	53	8.9	5	12.8	7.4	11.5	13.0	221 410 004 351 020 015
-	5/8" x 1/4"	C15V	31	25	53	10.6	6	15.4	6.2	10.2	11.6	221 410 022 351 020 015
10B-1	5/8" x 3/8"	C15V	31	25	53	10.6	6	15.4	9.3	13.5	14.9	221 410 005 351 020 015
12B-1	3/4" x 7/16"	C15V	31	25	53	12.4	7	17.0	11.3	15.9	17.5	221 410 006 351 020 015

Dimensions in mm - Separate ASA/JIS product catalogue available.

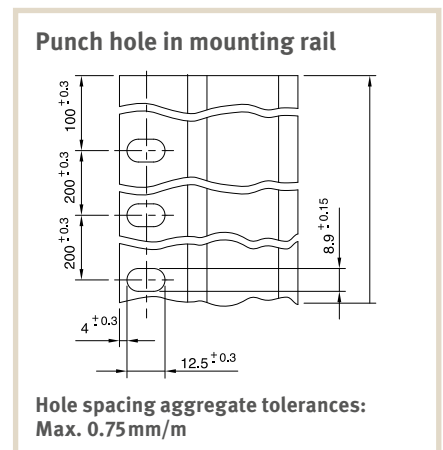
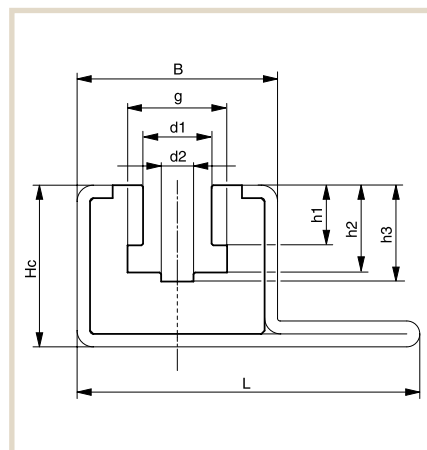

# Double-Decker Guides for Roller Chains as per DIN 8187

TYPE ETA



DIN 8187 chain no.	Chain dimensions in inches	C profile type	B	Hm	b	Bm	hm	Article no.
06B-1	3/8" x 7/32"		20	30.2	17	14.5	17	221 310 039
		C3						351 020 003
08B-1	1/2" x 5/16"		20	33.8	20	16.5	18	221 310 040
		C3						351 020 003
10B-1	5/8" x 3/8"		20	41.1	20	15.5	21	221 310 041
		C3						351 020 003
12B-1	3/4" x 7/16"		28	46.5	24	18.5	24	221 310 042
		C5						351 020 005
16B-1	1" x 17 mm		38	62.0	33	25.0	34	221 310 043
		C9						351 020 009

Dimensions in mm · Separate ASA/JIS product catalogue available.

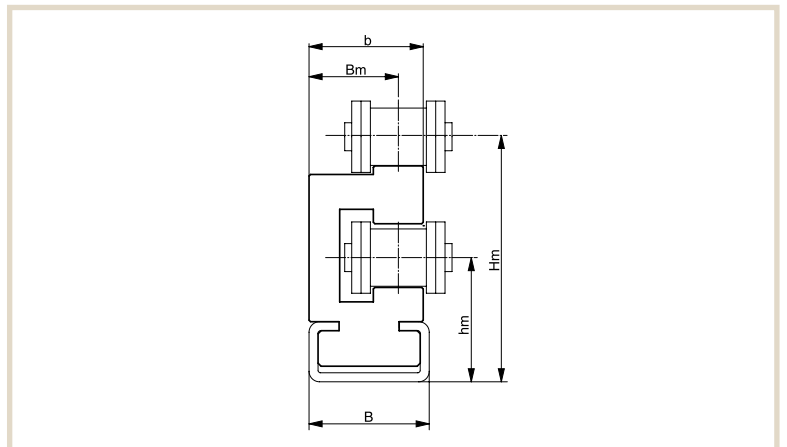

# Chain guides for round link chains as per DIN 766/764

## TYPE R



Nominal thickness d, DIN 766/764	B	H	d	h <sub>1</sub>	Article no.
6	30	15	7.0	7	231 010 001
8	38	20	9.0	9	231 010 002
10	45	25	11.5	11	231 010 003
13	55	30	15.0	15	231 010 004

Dimensions in mm

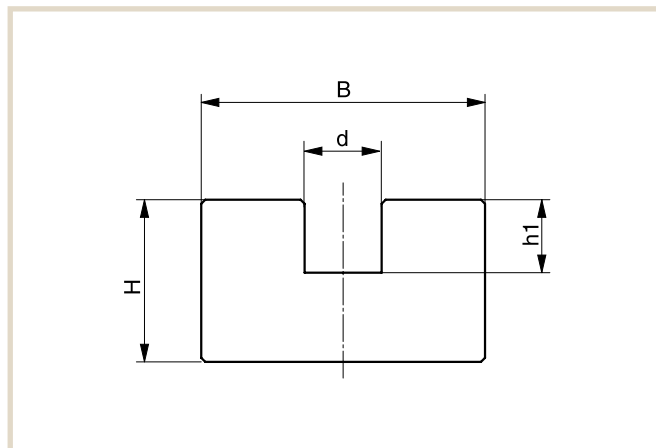

## TYPE CRU



Nominal thickness d, DIN 766/764	C profile type	B <sub>1</sub>	B <sub>2</sub>	H	H <sub>c</sub>	d	h <sub>1</sub>	Article no.
6		30		14	18	7.0	7	231 110 005
	C5		28					351 020 005
8		38		18	25	9.5	9	231 110 006
	C9		38					351 020 009
10		45		18	28	11.5	11	231 110 007
	C9		38					351 020 009
13		60		25	33	15.0	15	231 110 008
	C12		60					351 020 012

Dimensions in mm For round link chains that do not comply with DIN 766 or DIN 764 please specify dimensions.

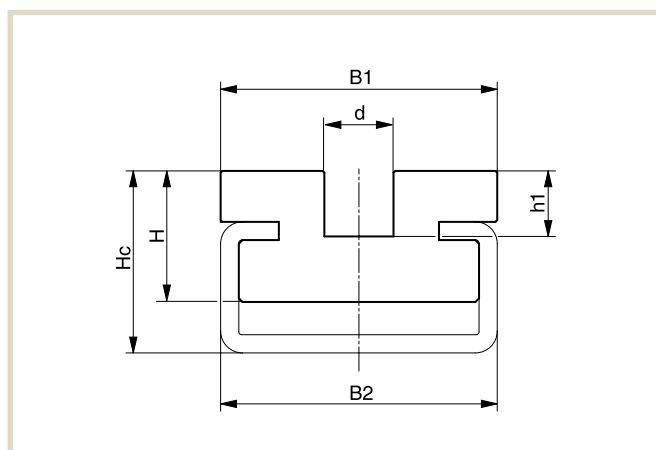

# TYPE CRG



Nominal thickness d, DIN 766/764	C profile type	B	Hc	d	h	Article no.
6	C11	45	40	7.0	8.0	231 110 009
						351 020 011
8	C11	45	40	9.5	9.5	231 110 010
						351 020 011
10	C13	65	55	11.5	14.0	231 110 011
						351 020 013
13	C13	65	55	15.0	18.0	231 110 012
						351 020 013

Dimensions in mm

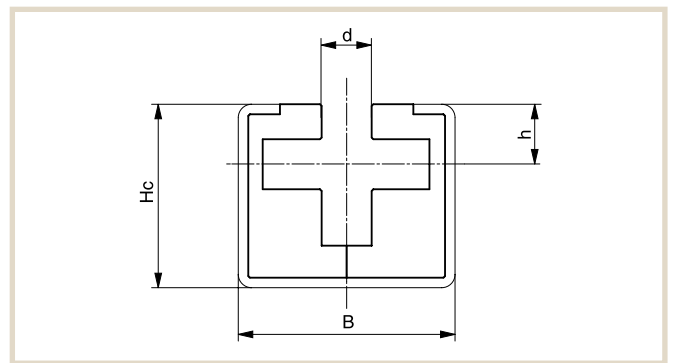

# TYPE CRO



Nominal thickness d, DIN 766/764	C profile type	B1	B2	H	Hc	d	h1	h2	Article no.
6	C3	27.0	20	32	34	7.0	17.5	10.5	231 110 001
									351 020 003
8	C5	32.0	28	39	42	9.5	20.5	12.5	231 110 002
									351 020 005
10	C9	42.5	38	53	56	11.5	25.5	16.5	231 110 003
									351 020 009
13	C12	60.0	60	67	70	15.0	33.5	20.5	231 110 004
									351 020 012

Dimensions in mm For round link chains that do not comply with DIN 766 or DIN 764 please specify dimensions.

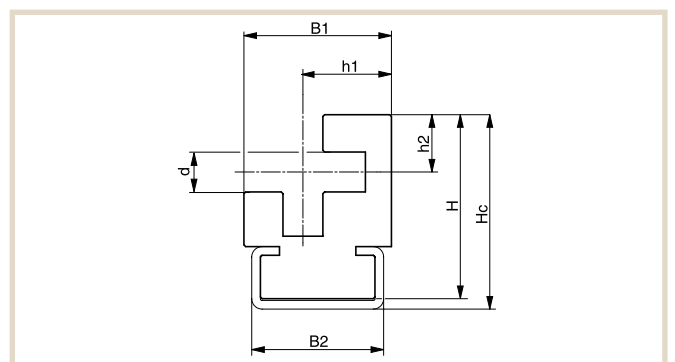

# OVERVIEW OF BELT GUIDES

## Plastic instead of metal

Belt guides made of metal cause a great deal of friction on the belts. By choosing a belt guide made of Material "S"<sup>®</sup> Black Antistatic, you considerably reduce this wear. In addition, you

save on drive energy thanks to the reduced static friction. Material "S"<sup>®</sup> Black Antistatic is suitable for use for round belts, V-belts, tooth belts and tracked tooth belts.

### For round belts

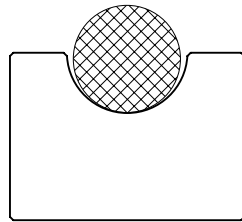

Type RR – page 95

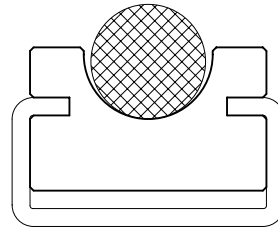

Type RRC – page 95

### For V-belts as per DIN 2215

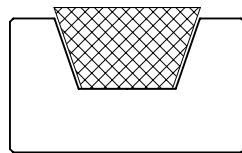

Type KR – page 96

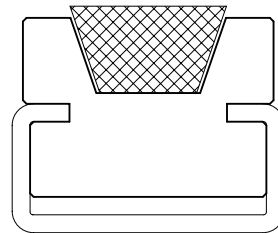

Type KRC – page 97

### For tooth belts

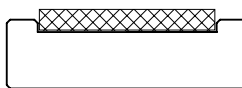

Type FR – page 98

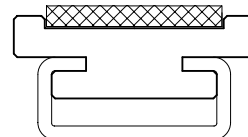

Type FRC – page 98

### For tracked tooth belts

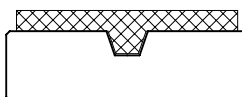

Type FK – page 99

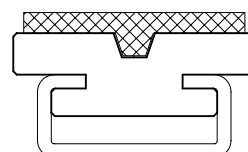

Type FKC – page 99



# Guides for Round Belts

## TYPE RR



Belt type / Ø	B	H	h	r	Article no.
5.0	20	10	3	3	231 010 027
6.3	20	10	4	4	231 010 028
8.0	20	12	5	5	231 010 029
9.5	25	15	6	6	231 010 030
12.5	28	20	8	7	231 010 031
15.0	33	25	10	9	231 010 032
18.0	38	25	12	10	231 010 033

Dimensions in mm

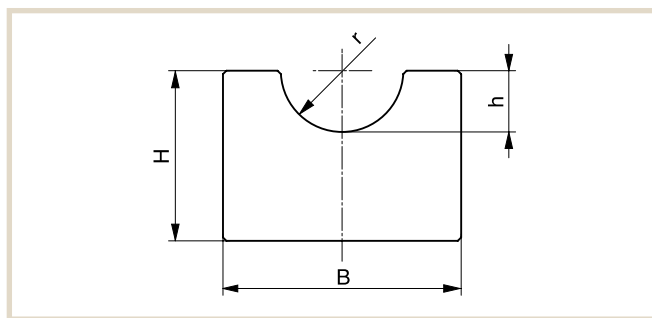

## TYPE RRC



Belt type / Ø	C profile type	B1	B2	H	Hc	h	r	Article no.
5.0	C3	20	20	10	15	3	3	231 110 035
								351 020 003
6.3	C3	20	20	15	18	4	4	231 110 036
								351 020 003
8.0	C3	20	20	15	18	5	5	231 110 037
								351 020 003
9.5	C5	25	28	15	20	6	6	231 110 038
								351 020 005
12.5	C5	28	28	15	20	8	7	231 110 039
								351 020 005
15.0	C9	33	38	20	25	10	9	231 110 040
								351 020 009
18.0	C9	38	38	20	25	12	10	231 110 041
								351 020 009

Dimensions in mm

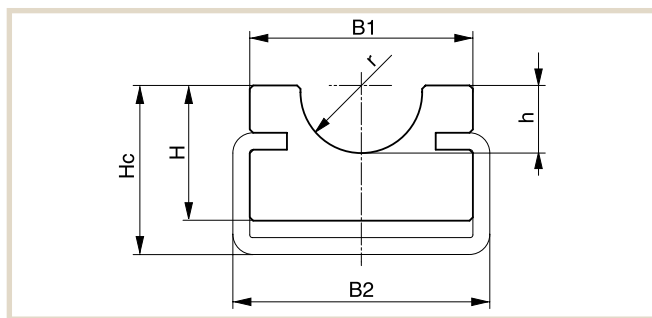

# Guides for V-belts as per DIN 2215

## TYPE KR



Belt type/b x h	B	H	b	h	Article no.
8 x 5	20	10	6.0	3.5	231 010 005
10 x 6	20	10	7.2	4.5	231 010 006
13 x 8	20	12	9.2	6.0	231 010 007
17 x 11	30	15	11.5	8.0	231 010 008
20 x 12.5	30	20	13.5	9.0	231 010 009
22 x 14	35	20	14.5	10.5	231 010 010
25 x 16	40	25	16.5	12.0	231 010 011
32 x 20	50	30	21.0	16.0	231 010 012
40 x 25	60	35	26.0	21.0	231 010 013

Dimensions in mm

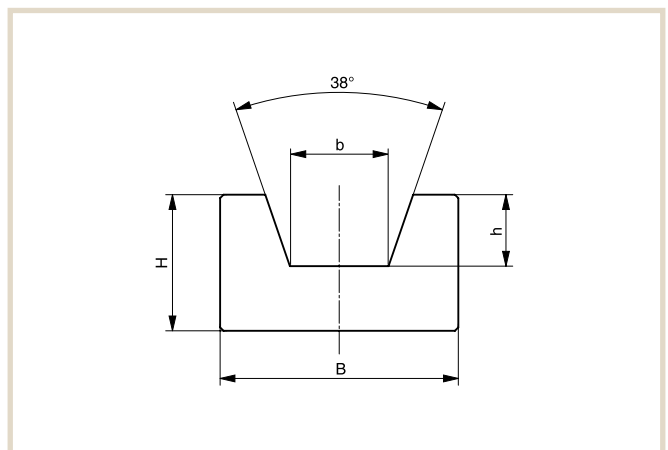

# TYPE KRC



Belt type/b x h	C profile type	B1	B2	H	Hc	b	h	Article no.
8 x 5	C3	20	20	10	15	6.0	3.5	231 110 013
								351 020 003
10 x 6	C3	20	20	15	18	7.2	4.5	231 110 014
								351 020 003
13 x 8	C5	25	28	18	22	9.2	6.0	231 110 015
								351 020 005
17 x 11	C5	30	28	18	24	11.5	8.0	231 110 016
								351 020 005
20 x 12.5	C5	30	28	18	24	13.5	9.0	231 110 017
								351 020 005
22 x 14	C9	35	38	25	30	14.5	10.5	231 110 018
								351 020 009
25 x 16	C9	40	38	25	32	16.5	12.0	231 110 019
								351 020 009
32 x 20	C12	60	60	35	40	21.0	16.0	231 110 020
								351 020 012
40 x 25	C12	60	60	35	40	26.0	21.0	231 110 021
								351 020 012

Dimensions in mm

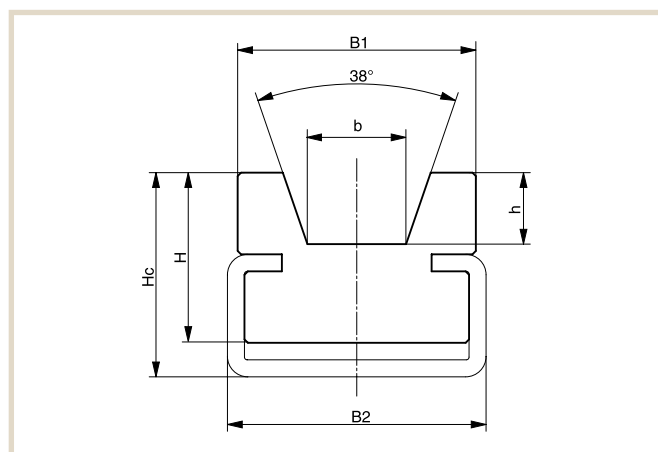

## Guides for tooth belts

### TYPE FR



Belt type	B	H	b	h	Article no.
25/T5	35	10	26	1.8	231 010 014
32/T5	45	12	33	1.8	231 010 015
25/T10	35	12	26	3.8	231 010 016
32/T10	45	12	33	3.8	231 010 017
50/T10	65	15	51	3.8	231 010 018
75/T10	90	15	76	3.8	231 010 019
100/T10	115	18	101	3.8	231 010 020

Dimensions in mm

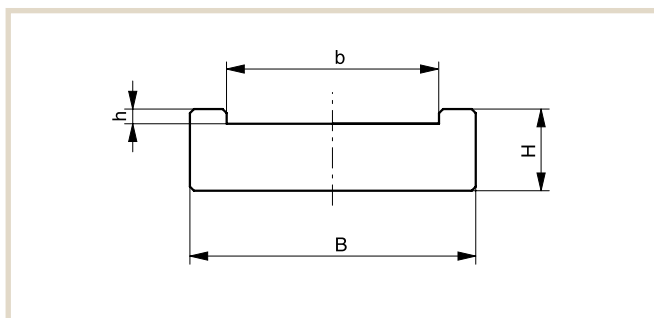

### TYPE FRC



Belt type	C profile type	B1	B2	H	Hc	b	h	Article no.
25/T5		35		12	18	26	1.8	231 110 022
	C5		28					351 020 005
32/T5		45		12	18	33	1.8	231 110 023
	C5		28					351 020 005
25/T10		35		15	20	26	3.8	231 110 024
	C5		28					351 020 005
32/T10		45		15	20	33	3.8	231 110 025
	C5		28					351 020 005
50/T10		65		18	20	51	3.8	231 110 026
	C4		50					351 020 004
75/T10		90		18	20	76	3.8	231 110 027
	C6		80					351 020 006
100/T10		115		18	20	101	3.8	231 110 028
	C6		80					351 020 006

Dimensions in mm

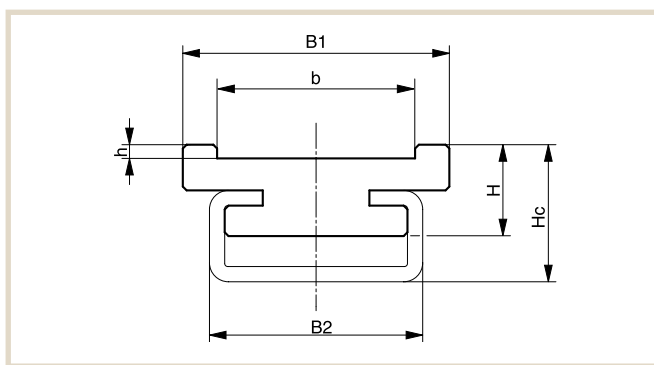

# Guides for tracked tooth belts

## TYPE FK



Belt type	B	H	b	h	Article no.
25/TK5	28	10	6.0	3.5	231 010 021
32/TK5	35	10	6.0	3.5	231 010 022
32/TK10*	35	12	9.5	4.0	231 010 023
50/TK10*	55	12	9.5	4.0	231 010 024
75/TK10	80	15	13.0	5.0	231 010 025
100/TK 10	105	15	13.0	5.0	231 010 026

Dimensions in mm

\* Standard for V-profile 10 x 6; specify any deviations!

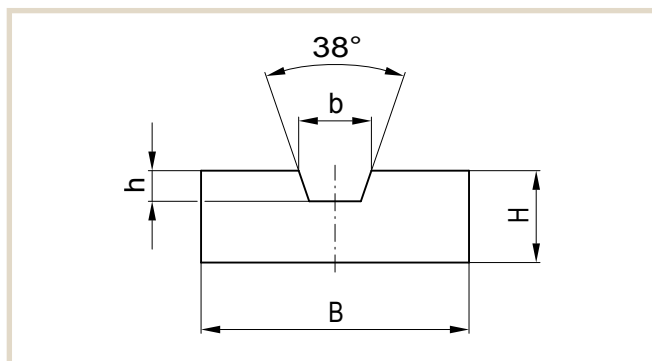

## TYPE FKC



Belt type	C profile type	B1	B2	H	Hc	b	h	Article no.
25/TK 5		28		12	18	6.0	3.5	231 110 029
	C5		28					351 020 005
32/TK 5		35		12	18	6.0	3.5	231 110 030
	C5		28					351 020 005
32/TK10*		35		12	18	9.5	4.0	231 110 031
	C5		28					351 020 005
50/TK10*		55		15	18	9.5	4.0	231 110 032
	C4		50					351 020 004
75/TK10		80		15	18	13.0	5.0	231 110 033
	C6		80					351 020 006
100/TK10		105		15	18	13.0	5.0	231 110 034
	C6		80					351 020 006

Dimensions in mm

\* Standard for V-profile 10 x 6; specify any deviations!

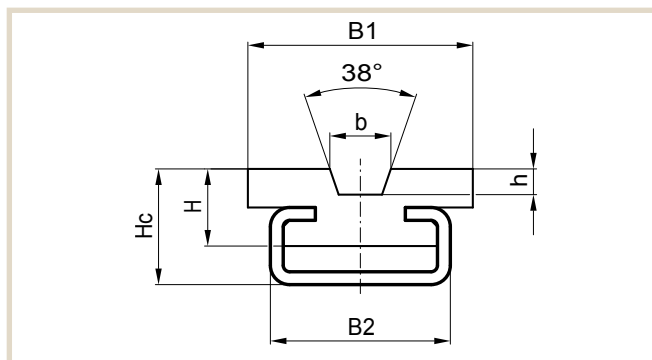

# CHAIN RACKS

Good value, flexible, and robust

Our chain racks have more than proven themselves as an economical alternative to milled racks. The system is characterized by ease of installation and simple adjustment, and is attached using an anchor plate at one end and a clamping set at the other end.

## Design

The clamping set is connected with the actual chain rack using a simplex chain connecting link. The chain is guided using a cage profile made of Material "S"<sup>®</sup>1000 green. This is clasped by a steel C profile from the outside. The steel C profiles are fixed to the base using clamps. For chain lengths of more than 2,500 mm, fastening brackets are also provided. They are integrated into the rack using duplex connection elements. This prevents the chain rack from moving in the cage profile during start-up and deceleration. Chain racks are available in chain sizes of 1/2", 5/8", 3/4" and 1".

For the full range of chain racks and prices, see [www.murtefeldt.com](http://www.murtefeldt.com).

## Advantages

- Less sensitive to tooth backlash changes. Alignment errors can thus be corrected through smaller sprocket widths
- High level of acoustic insulation
- High stability
- Cage profile can expand if temperature varies
- Simple assembly
- Economical alternative to milled racks

## Chain rack composition

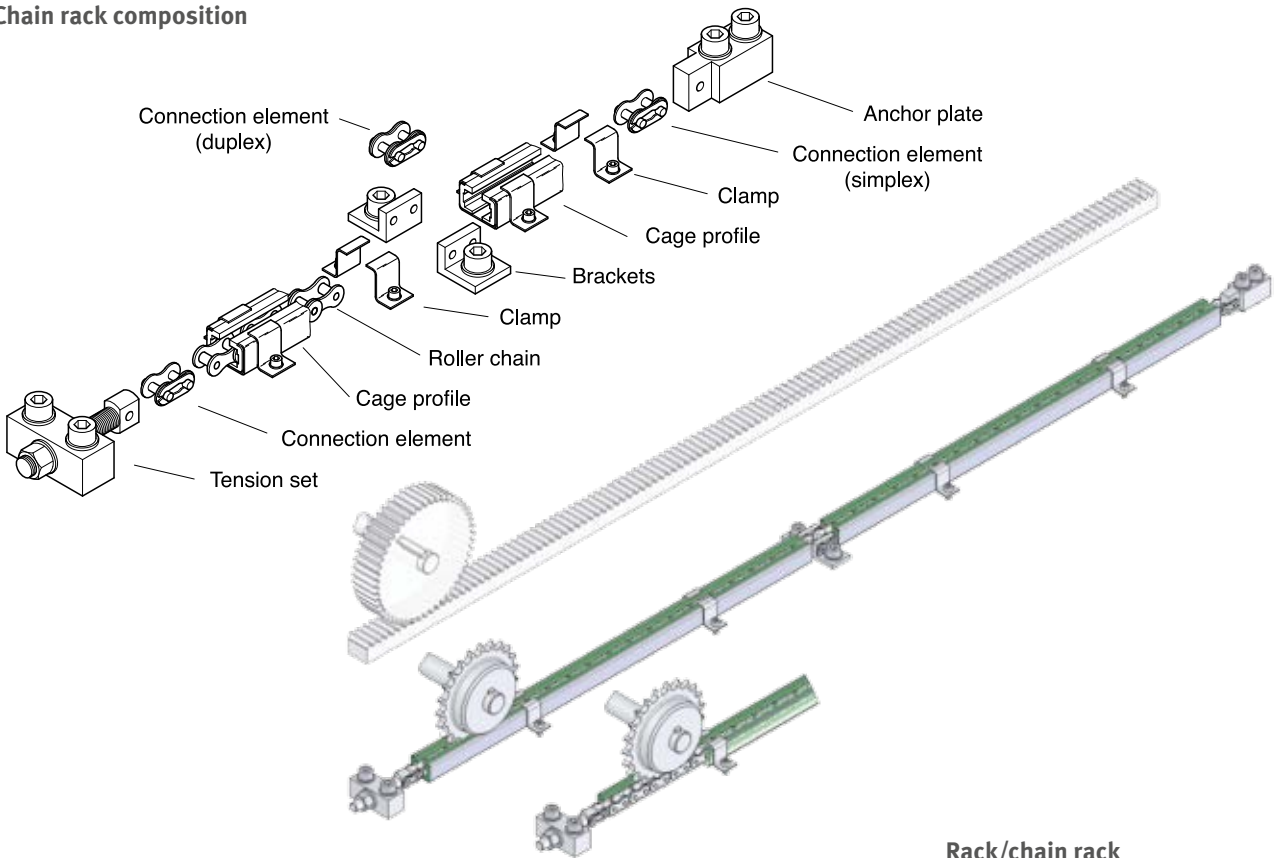

Rack/chain rack

# PROFILES FOR CONVEYING AND TRANSPORTATION

In the beverage, packaging, food, and frozen food sectors in particular, goods and products must be transported in a reliable manner that protects them from damage. We offer a wide range of products to meet this requirement.

We are happy to manufacture products on the basis of your drawings to meet the demands of your custom conveying and transport tasks. For example, we can produce carriers and work piece bearers for your conveyor belts. You can also obtain accessories such as switches and star wheels quickly and economically and in line with your requirements.

Please contact our application technology department or one of our field staff. You can also join our consultants at an online conference where you can work together on your documents in real time.

For information on the required access software for online collaboration, see [www.murtfeldt.com](http://www.murtfeldt.com).

## We offer the following products for conveying/ transportation technology:

- Sliding guides
- Rail guides
- Bands
- Clip-on profiles
- Profiles for slat band chains
- Curve guides for slat band chains

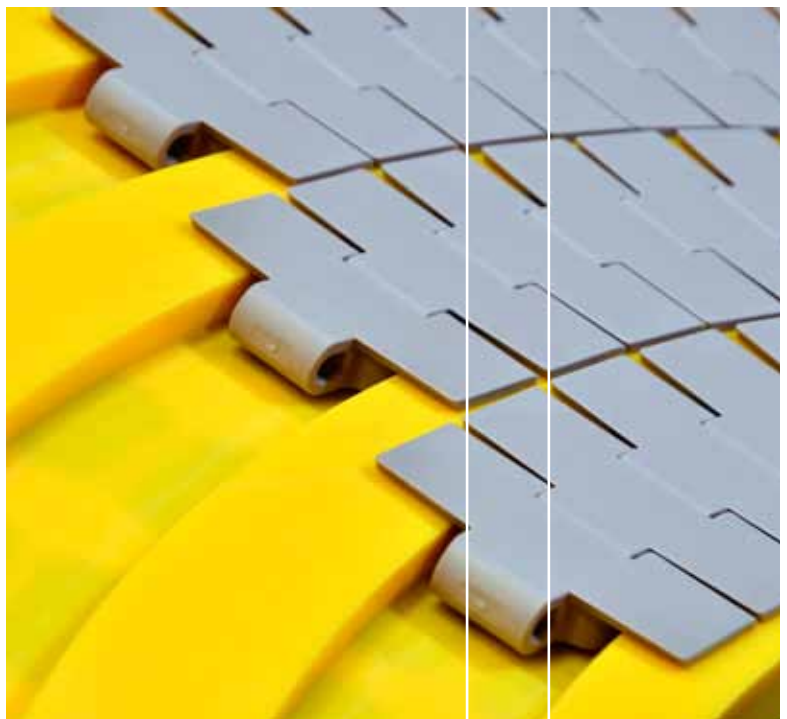
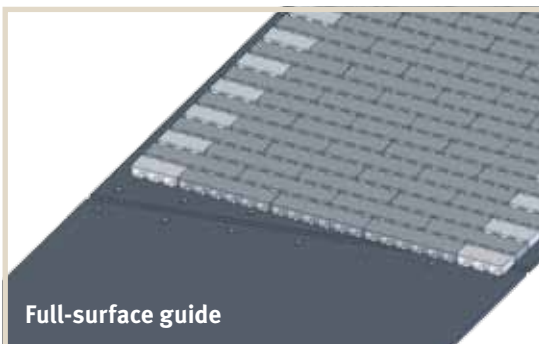
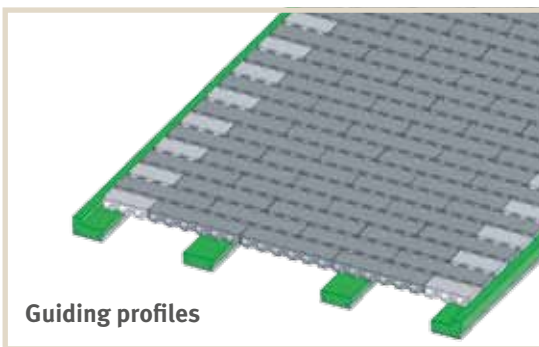

# Sliding guides

## SLIDING GUIDES TYPE CF



Type	C profile type	B1	B2	H	Hc	h	Article no.
CF		20		5	6	1.0	211 010 001
	C1		24				351 020 001
CF		20		10	11	5.8	211 010 002
	C1		24				351 020 001
CF		20		10	14	4.0	211 010 003
	C3		20				351 020 003
CF		20		14	17	7.0	211 010 004
	C3		20				351 020 003
CF		20		16	20	10.0	211 010 005
	C3		20				351 020 003
CF		28		10	15	3.0	211 010 006
	C5		28				351 020 005
CF		28		14	18	6.0	211 010 007
	C5		28				351 020 005
CF		38		12	22	4.0	211 010 008
	C9		38				351 020 009
CF		38		18	25	7.0	211 010 009
	C9		38				351 020 009
CF		60		20	30	10.0	211 010 010
	C12		60				351 020 012
CF		50		18	20	10.0	211 010 011
	C4		50				351 020 004
CF		80		18	20	10.0	211 010 012
	C6		80				351 020 006

Dimensions in mm

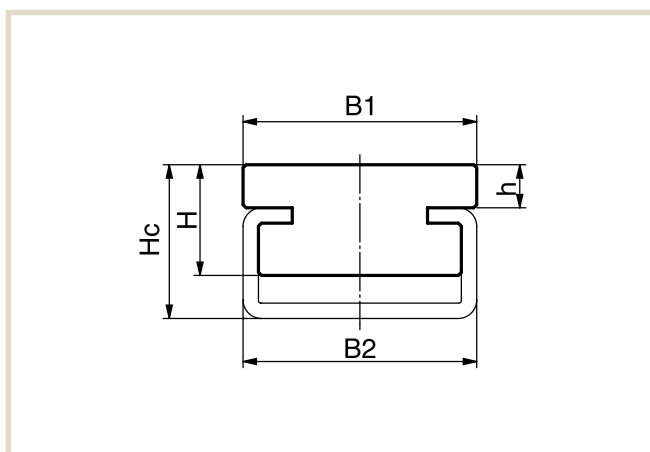



# RAIL GUIDES

## As insertion and clip profiles



Here, we present a small selection of our wide range of profiles for exemplary purposes. For our full range, see [www.murtefeldt.com](http://www.murtefeldt.com).

Rail profile	Delivery form	Delivery length in mm	Production method	Original Material "S" <sup>®</sup>	Article no.
Mushroom profile HR 2020	profile	2000	milled	green	211 210 001
	C3	2000			351 020 003
	profile	2000	milled	black antistatic	211 210 002
	C3	2000			351 020 003
	profile	2000	extruded	green	211 210 003
	C3	2000			351 020 003

Dimensions in mm Extruded profiles made of Material "S" Black are **not** antistatic.

\* For milled profiles. Tolerances as per DIN 16941 for extruded profiles.

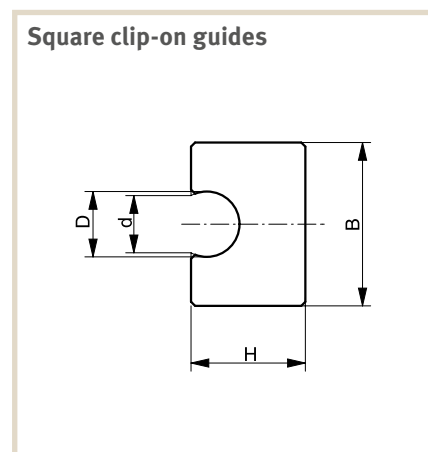
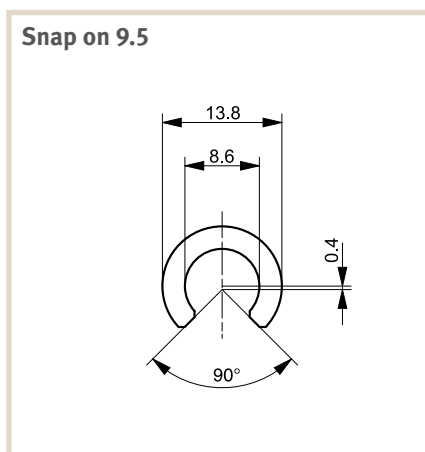
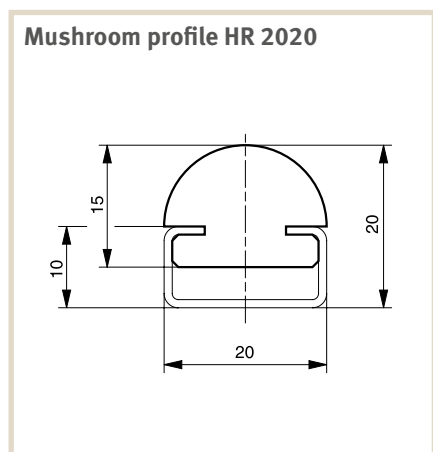



Murtfeldt plastic bands are ideally suited for transporting sensitive goods. They are available in three standard sizes. Intermediate and special dimensions are available on request.

We are happy to advise you on the correct choice of band. Please contact us.

### Design

- Either in Original Material "S"<sup>®</sup> green or Original Material "S"<sup>®</sup> Black Antistatic
- On request: Pre-treatment in the form of scraping and flaming on one side for later adhesion

### Special designs

- 6, 8 and 10mm in widths of between 10 and 60mm

### Applications

- Beverage, packaging, food, and frozen food sectors

### Special properties

- Extremely good wear resistance
- High shock and impact resistance

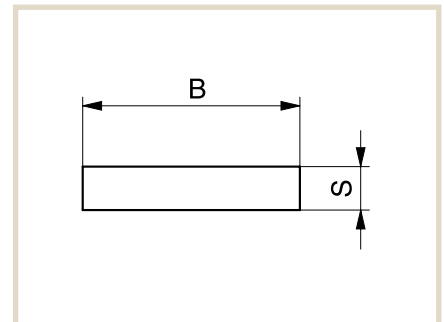

## Bands made from Original Material "S"<sup>®</sup> green

Width (B) x thickness (S)	Article no.
15 x 3	171 010 007
18 x 3	171 010 008
20 x 3	171 010 009
22 x 3	171 010 010
25 x 3	171 010 011
30 x 3	171 010 012
35 x 3	171 010 013
40 x 3	171 010 014
45 x 3	171 010 016
50 x 3	171 010 017
60 x 3	171 010 019
70 x 3	171 010 020
80 x 3	171 010 021
90 x 3	171 010 023
100 x 3	171 010 024
111 x 3	171 010 025

Width (B) x thickness (S)	Article no.
20 x 4	171 010 026
25 x 4	171 010 027
30 x 4	171 010 028
40 x 4	171 010 030
50 x 4	171 010 032

Width (B) x thickness (S)	Article no.
15 x 5	171 010 034
18 x 5	171 010 035
20 x 5	171 010 036
22 x 5	171 010 037
25 x 5	171 010 038
30 x 5	171 010 039
35 x 5	171 010 040
40 x 5	171 010 041
45 x 5	171 010 042
50 x 5	171 010 043
60 x 5	171 010 044

\* Tolerances: Thickness ± 0.1 / width ± 0.5. Roll length on request

# SLIP-ON PROFILES



Here is a small selection of our extensive range of profiles.  
View our complete range at [www.murtefeldt.com](http://www.murtefeldt.com).

**Plastic C profile for flat steel, 30 × 3 milled/extruded**

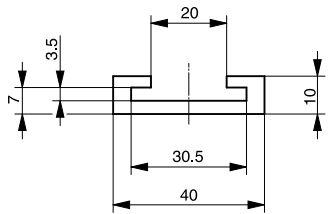

**Plastic C profile for flat steel, 40 × 8 milled**

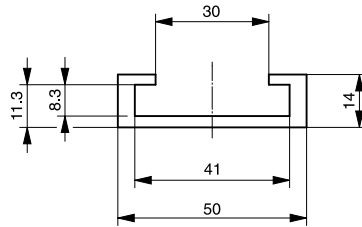

**Plastic C profile for flat steel, 40 × 8 extruded**

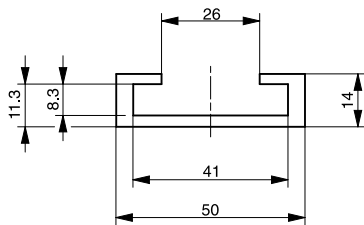

**Plastic C profile for flat steel, 40 × 10 milled**

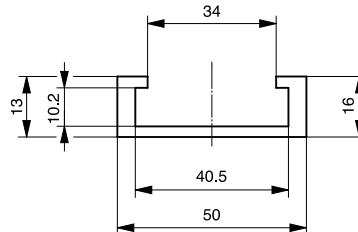

**Plastic C profile for flat steel, 40 × 10 extruded**

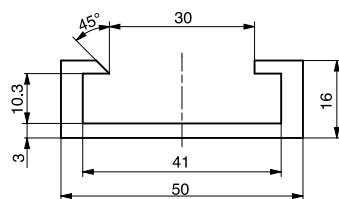

**Plastic C profile for flat steel, 50 × 6 milled**

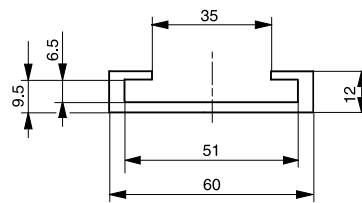

**Plastic C profile for flat steel, 50 × 6 extruded**

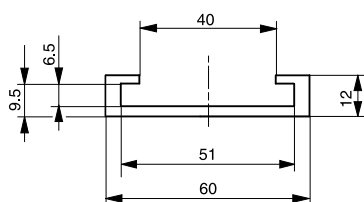

**Plastic L profile for flat steel, 40 × 8 milled**

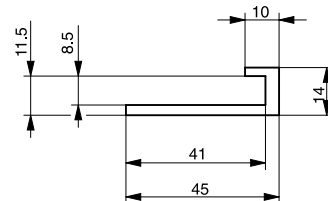

\* For milled profiles. Tolerances as per DIN 16941 for extruded profiles.

# PROFILES FOR SLAT BAND CHAINS



**L profile 20 x 5**

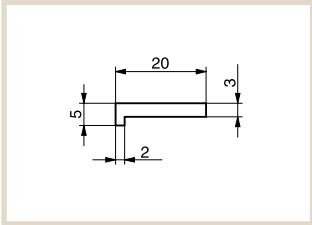

**L profile 20 x 5.5**

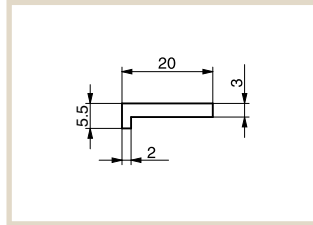

**L profile 20 x 6**

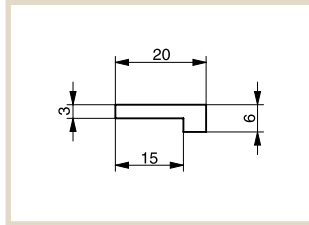

**L profile 25 x 6**

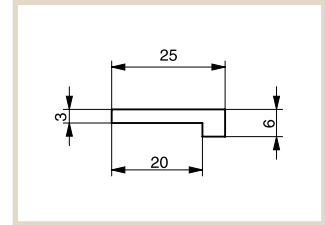

Profile	Roll length (in m)	Production method	Original Material™S™®	Article no.
L profile 20 x 5	35	milled	green	211 310 034
L profile 20 x 5.5	50	extruded	green	211 310 044
L profile 20 x 6	45	milled	green	211 310 035
L profile 25 x 6	45	milled	green	211 310 036

**Slide profile type U 45 x 6**

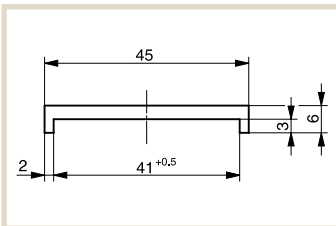

**Centre profile 40 x 6**

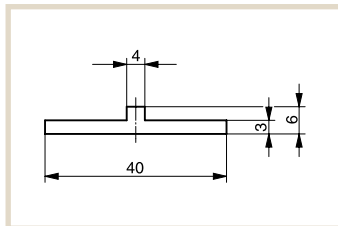

**Centre profile 40 x 5.5**

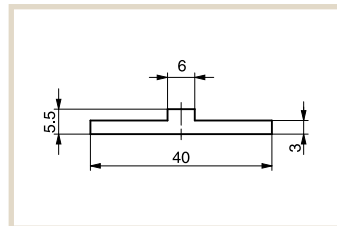

Profile	Roll length (in m)	Production method	Original Material™S™®	Article no.
Slide profile type U 45 x 6	35	milled	green	211 310 037
Centre profile 40 x 6	35	milled	green	211 310 033
Centre profile 40 x 6	50	extruded	green	211 310 042
Centre profile 40 x 5.5	50	extruded	green	211 310 001

**Bridge centre profile 40 x 7.5**

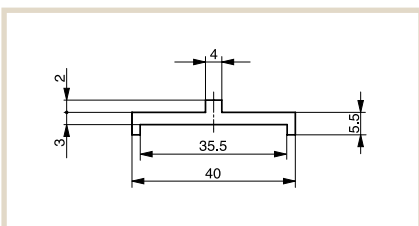

**Bridge centre profile 45 x 15**

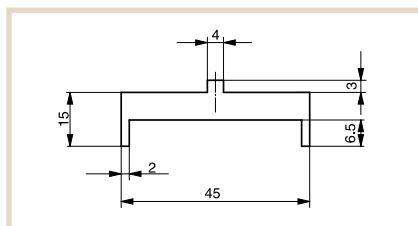

Profil	Roll length (in m)	Production method	Original Material™S™®	Article no.
Bridge centre profile 40 x 7.5	50	extruded	green	211 310 043
Bridge centre profile 45 x 15	6	extruded	green	211 310 002

Dimensions in mm Extruded profiles made of Material "S" black are **not** antistatic.

\* For milled profiles. Tolerances as per DIN 16941 for extruded profiles.

# PROFILES FOR SLAT BAND CHAINS



**Flat clamping profile 21 x 9**

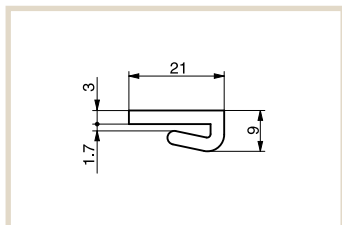

**Flat clamping profile 26 x 11.8**

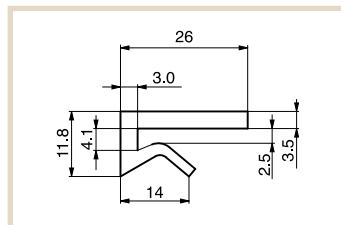

Profile	Roll length (in m)	Production method	Original Material™S™®	Article no.
Flat clamping profile 21 x 9	50	extruded	green	211 310 004
Flat clamping profile 26 x 11.8	50	extruded	natural	211 310 039

**L clamping profile 21 x 11**

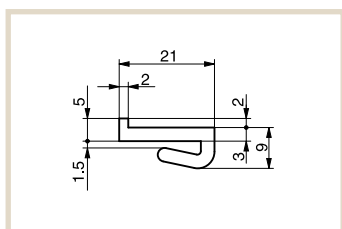

**L clamping profile 22 x 11**

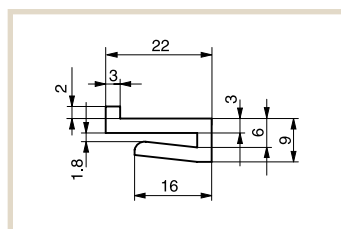

**L clamping profile 26 x 14.8**

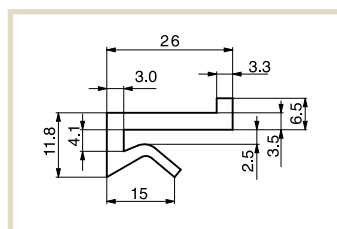

Band profile	Roll length (in m)	Production method	Original Material™S™®	Article no.
L clamping profile 21 x 11	50	extruded	green	211 310 005
L clamping profile 22 x 11	65	extruded	green	211 310 041
L clamping profile 26 x 14.8	30	extruded	natural	211 310 040

**Clamping U profile 6.3 x 8.7**

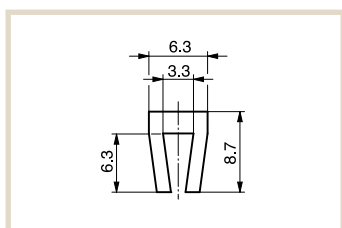

**T clip-on profile 40 x 20.5**

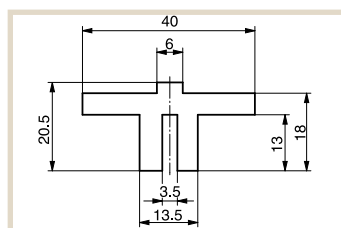

**Z profile 20 x 8**

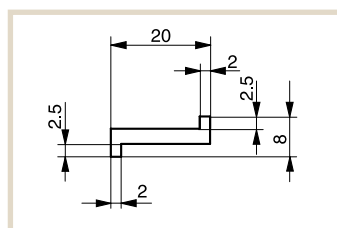

Profile	Roll length (in m)	Production method	Original Material™S™®	Article no.
Clamping U profile 6.3 x 8.7	50	extruded	natural	211 310 007
T clip-on profile 40 x 20.5	2	milled	green	211 310 030
Z profile 20 x 8	35	milled	green	211 310 031
	50	extruded	green	211 310 038

## CURVE GUIDES FOR SLAT BAND CHAINS

### Made-to-measure or off the shelf

Steel slat-band chains are preferable for the transport of bottles and components, like coupling components, bearings or gears. To significantly reduce abrasion as well as background noise when handling these components, Murtfeldt recommends the use of plastic curve guides. These guides are ideal for the transport of sensitive products, avoiding breakage of glass bottles, preventing crushing with dairy products and avoiding scratching with PET bottles.

These curve guides form part of Murtfeldt's standard range. However, Murtfeldt's capacity to produce curve guides tailored to the customers' specific requirements is even greater.

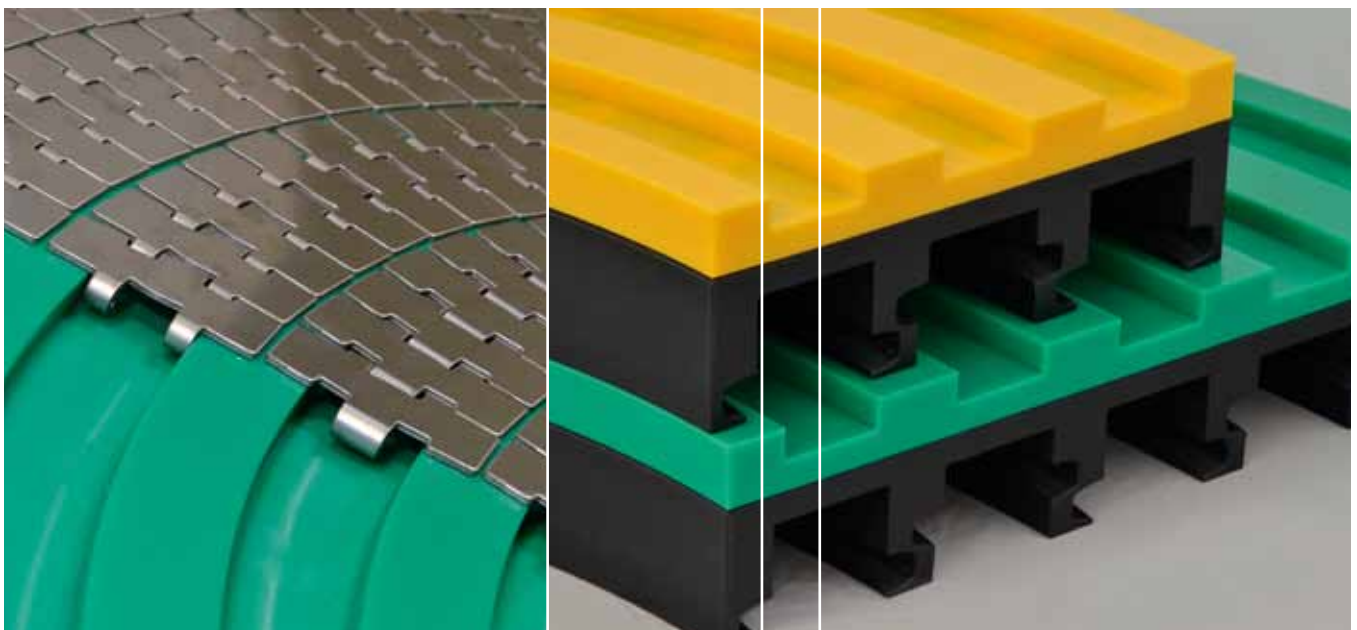

# CURVE GUIDES FOR SLAT BAND CHAINS

Shown with TAB guide, with and without straight ends

Our production plant is state of the art and professionally set up for the production of individual TAB, dovetail and magnetic curve guides. We can make your detailed requirements a reality. Download the TAB design questionnaire below on our website, as well as the questionnaires for dovetail and magnetic curve guides.

Further questionnaires are available to download at [www.murtfeldt.com/services/design-questionnaires/](http://www.murtfeldt.com/services/design-questionnaires/)

Please use the questionnaire to provide us with the necessary technical data or get in touch with our application engineers who will be pleased to help you immediately with producing the necessary drawings.

## YOUR CONTACT DETAILS

Name, first name	
Company	
Postal code, city	
Street	
Phone	
Fax	
E-Mail	

## TEAM APPLICATION TECHNOLOGY

We are happy to provide free, non-binding advice on selecting the suitable design and material of your curve guide.

Please send the fill-out form to:

**technik@murtfeldt.de**

or print it out and send it by fax to:

**Fax 0049 (0) 231 20609-518**

## DIMENSIONS IN MM

H		R1		Segment angle	
B		R2		Length (with straight ends)	
b1		R3		a	
b2		R4			
h1		R5			
h2		R6			

## BAUART

Countersunk hole	YES	NO	Quantity		/
Thread insert	YES	NO	Quantity		/
Material for curve guide					
Type of chain					

## REMARKS

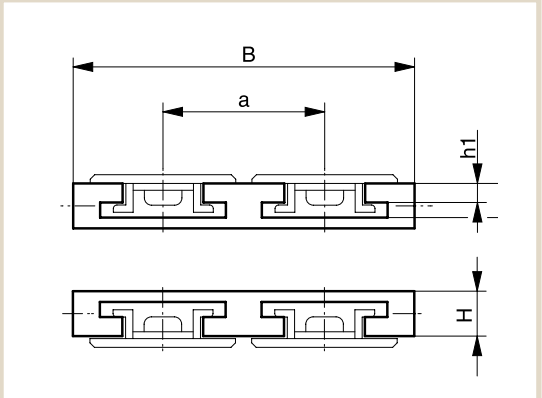
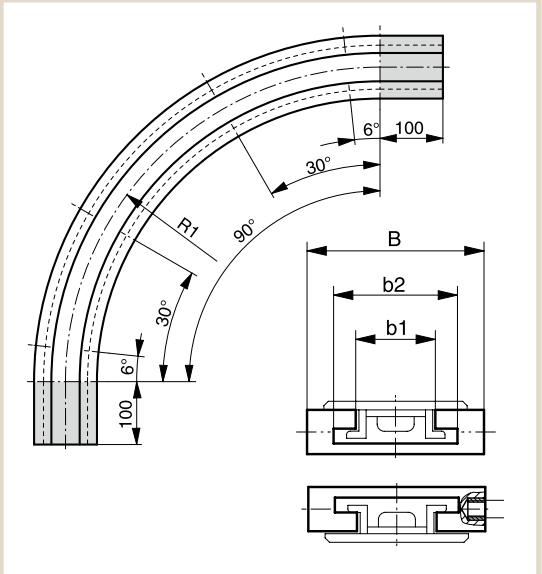
# GUIDES FOR MODULAR BELTS

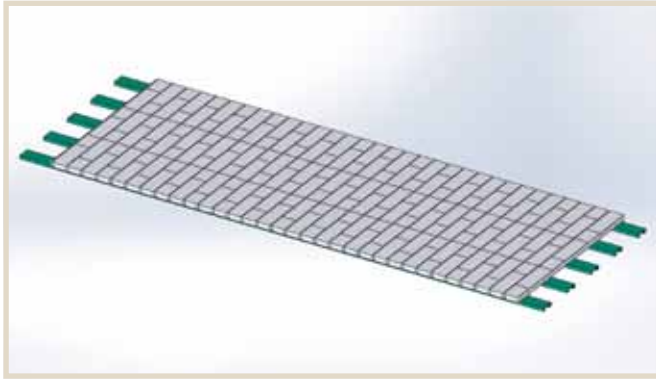

Slip-on profiles

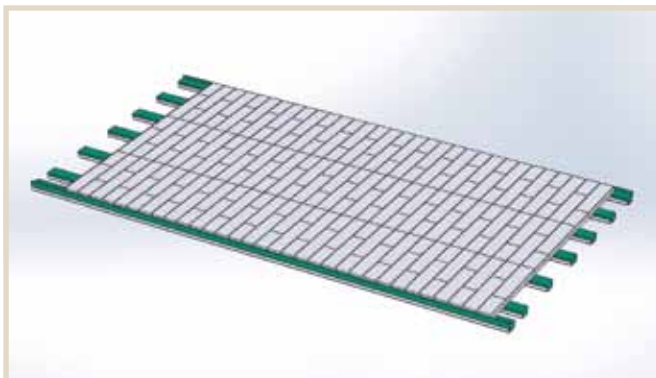

CF profiles

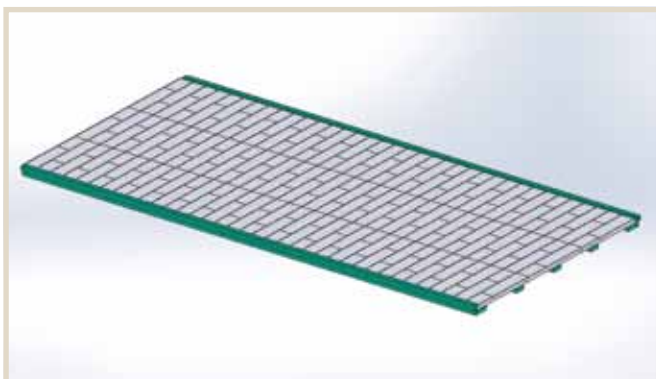

Flat profiles with hold-down clips

Conveyor belts are highly modular and can even be integrated into the most complex systems. Murtfeldt Plastics produces guides for modular belts, manufactured from highly wear-resistant, low-friction plastics like Original Material "S"<sup>®</sup> green, "S"<sup>®</sup> plus+ LF or "S"<sup>®</sup> plus+ ESD. These guides are used as solid sliding bases, and also as CF profiles, slip-on profiles or sliding guides with tongue and groove in a straight or an arrow-shaped arrangement. You will find our solutions in almost all sectors, in the packaging industry, as well as in filling plants or in the automotive sector.

## At a glance: Guides for modular chains

- Flat profiles
- Profiles with hold-down clips
- Slip-on profiles (C for flat steel)
- CF profiles
- Flat profiles with tongue and groove
- V-shaped flat profiles
- Solid guides (based on a drawing)

## Materials

- Original Material "S"<sup>®</sup> plus+ LF
- Original Material "S"<sup>®</sup> plus+ LF ESD
- Original Material "S"<sup>®</sup> plus+ ESD
- Original Material "S"<sup>®</sup> plus+ Bright ESD
- Original Material "S"<sup>®</sup> black antistatic

## Benefits

- Low sliding friction
- Excellent wear resistance
- No static charge depending on the design



# GUIDES FOR MODULAR BELTS

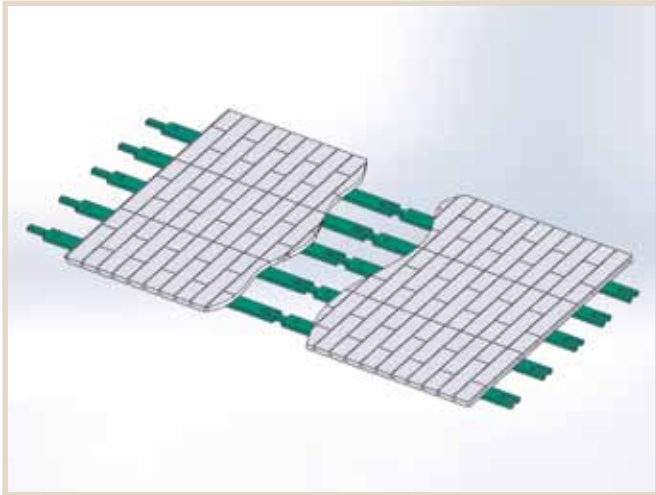

Flat profiles with tongue and groove

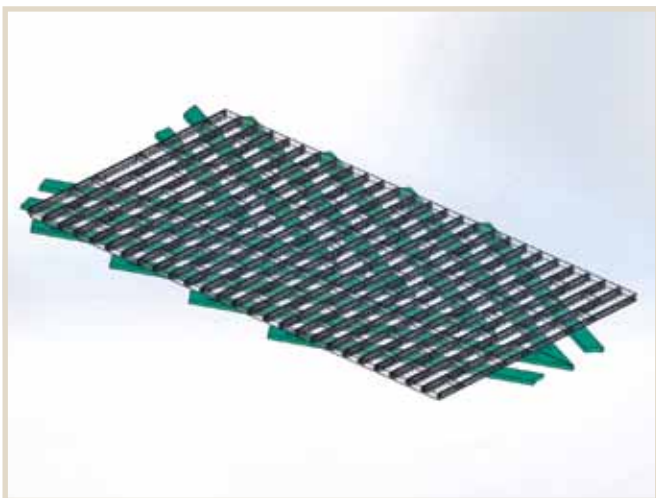
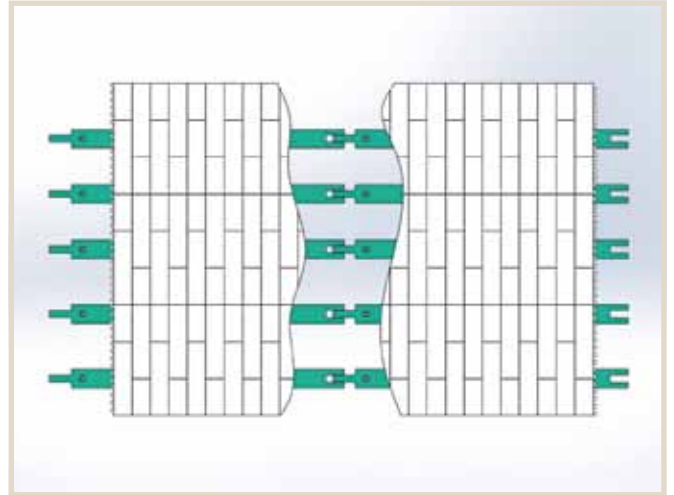

Arrow shape

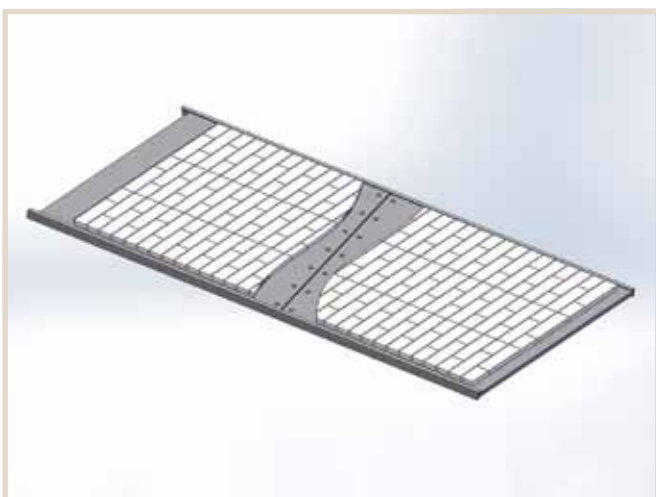
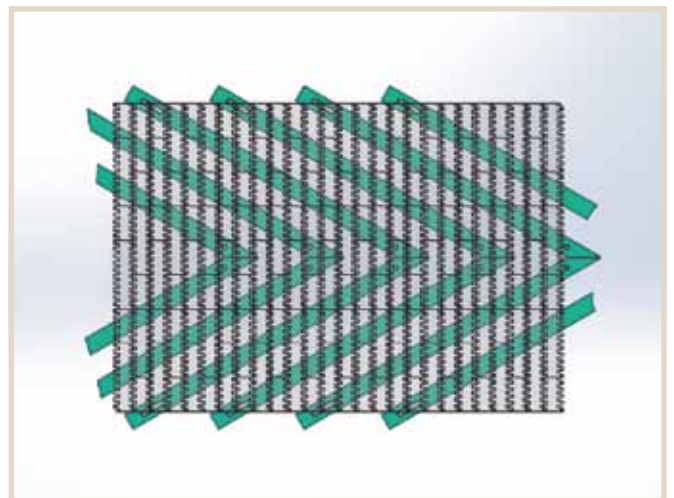

Solid sliding base

