

ROLLON[®]
BY TIMKEN

Telescopic Line



General catalogue
English

Interactive catalogs
on: www.rollon.com



We design and produce in order to support you

*An international group
for technology,
a local support for service*

*Over 40 years of know how
in design and production*

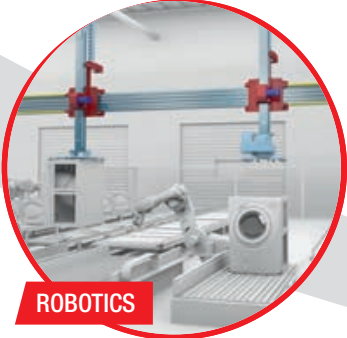
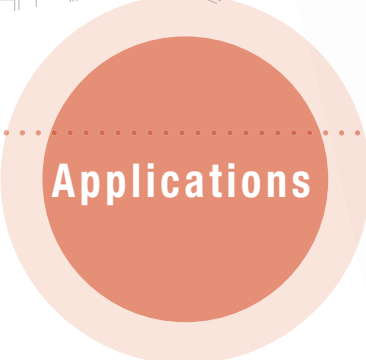
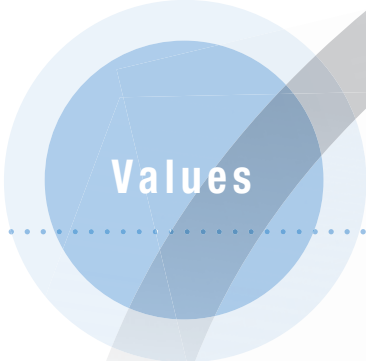
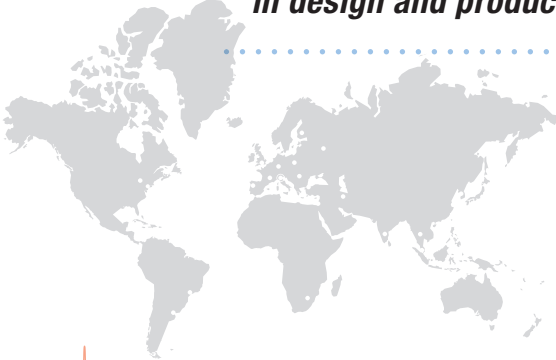

ROBOTICS

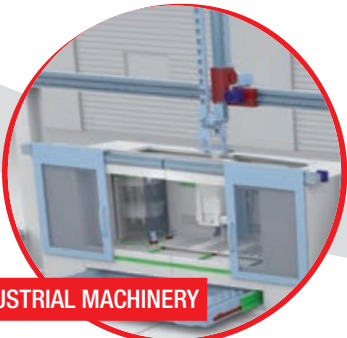

INDUSTRIAL MACHINERY

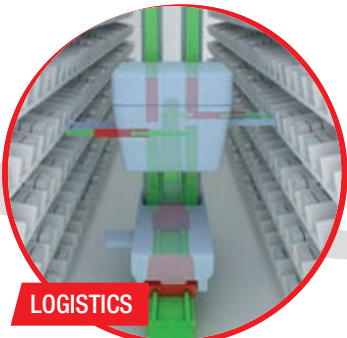

LOGISTICS



RAILWAY

Collaboration

High level technical consulting

Cross competences in several industrial sectors for an effective problem-solving

Solutions

From a full range of standard products to fit-to-customer solutions for best performances

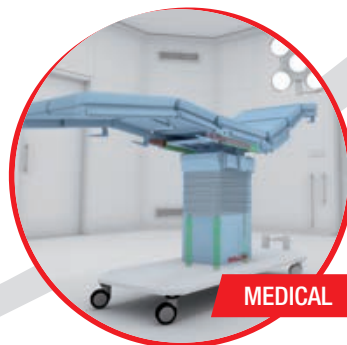

A complete range for linear motion which reaches every customer



Linear and curved guides with ball and roller bearings, with hardened raceways, high load capacities, self-alignment and capable of working in dirty environments.

Linear Line



Telescopic Line

Telescopic guides with ball bearings, with hardened raceways, high load capacities, and low bending, resistant to shocks and vibrations. For partial, total or extended extraction up to 200% of the length of the guide.



Actuator Line

Linear actuators with different guide configurations and drives, available with belt, screw or rack and pinion drives according to different needs in terms of precision and speed. Guides with bearings or ball recirculating systems for different load capacities and critical environments.

*A global provider
of solutions
for applications
for linear motion*



Actuator System Line

Integrated actuators for industrial automation, they find applications in numerous industrial sectors: from machinery servo systems to high precision assembly systems, packaging lines and high speed production lines. It has evolved from Actuator Line series in order to meet the most demanding needs of our customers.

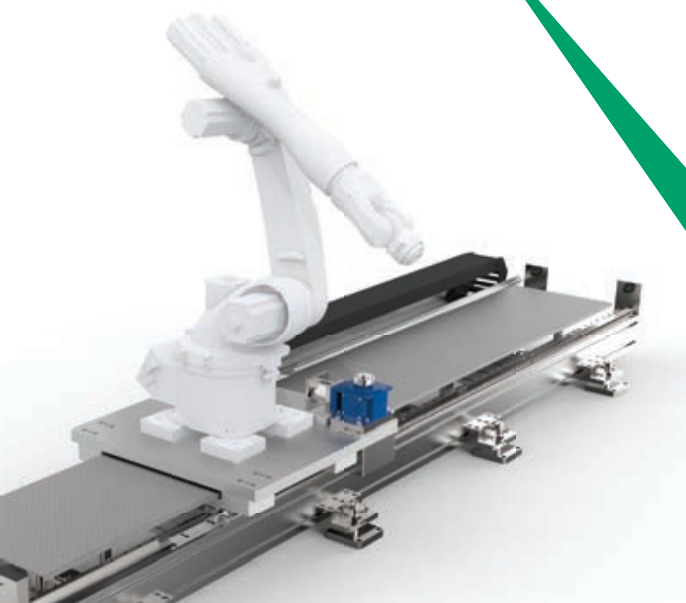

> **Telescopic Rail**



Technical features overview

1 Product explanation

Telescopic Rail: Seven models with full and partial extension

TR-2

2 Product cross sections

TR-5

3 Technical data

Performance characteristics and notes

TR-7

4 Dimensions and load capacity

ASN

TR-8

DSS

TR-12

DSS...S

TR-14

DSB

TR-16

DSD

TR-17

DSE

TR-19

DSC

TR-21

DE

TR-23

DE...S

TR-26

DE...D

TR-28

DE...Z

TR-30

DBN

TR-32

DMS

TR-34

5 Technical instructions

Telescopic rail selection, Static load check

TR-36

Deflection

TR-37

Static load

TR-38

Service life

TR-39

Speed, Extension and extraction force,

Double-sided stroke, Temperature

TR-42

Anticorrosive protection, Lubrication, Clearance and preload

TR-43

Fixing screws

TR-44

Installation instructions

TR-45

Ordering key

Ordering key with explanations

TR-47

> Hegra Rail



1 Product explanation Partial and full extension guides of different types	HR-2
2 Product cross sections	HR-4
3 Technical data Performance characteristics and notes	HR-6
4 Load capacities and dimensions HTT HVC H1C H1T H2H LTH HGT LTF HGS	HR-7 HR-11 HR-16 HR-18 HR-22 HR-24 HR-31 HR-35 HR-37
5 Accessories Locking, driving disc, damping	HR-39
6 Technical information Selecting a suitable telescoping rail, Mounting tolerances, Life cycle, Load capacity, Deflection, Operating temperature, Corrosion protection, Ball cage displacement, Moving force, Lubrication, Clearance and preload Maintenance intervals, Assembly information	HR-40 HR-41 HR-42
Ordering key Ordering key with explanations	HR-43

> Telerace



1 Product explanation

Telerace roller telescopic slides

TLR-2

2 Overview product cross sections

Series TLR-TLQ, series TLN-TQN, series TLAX-TQAX

TLR-4

3 General characteristics

TLR-TLQ series

TLR-5

TLN-TQN and TLAX-TQAX series

TLR-6

4 Dimensions and load capacity

TLR

TLR-7

TLQ

TLR-10

TLN

TLR-13

TQN

TLR-15

TLAX

TLR-18

TQAX

TLR-20

Sizing of telescopic applications

TLR-22

Verification of load capacity

TLR-23

Lifetime calculation

TLR-24

Ordering key

> **Light Rail**



1 Product explanation

Light telescopic rails, with full or partial extension

LR-2

2 Product cross sections

LR-4

3 Technical data

Performance characteristics and notes

LR-5

4 Dimensions and load capacity

LPS

LR-6

LFS

LR-7

LFS

LR-8

LFS SC

LR-9

LFS

LR-10

LFX

LR-11

Fixing screws

LR-12

5 Technical instructions

Load capacities

LR-13

Speed, Temperature, Lubrication, Corrosion protection

LR-14

Installation instructions

LR-15

Ordering key

Ordering key with explanations

LR-16

Guides suitable for all applications

Technical features overview



Reference			Product name	Extraction	Size	Profile		Self alignment	Slider		Steel
Product Family	Product	Section				Type	Hardened raceways		Balls	Rollers	
Telescopic Rail	ASN		ASN22		22	Cold Draw	■	+	■		■
			ASN28		28						
			ASN35		35						
			ASN43		43						
			ASN63		63						
	DE		DE...22		22	Cold Draw	■	++	■		■
			DE...28		28						
			DE...35		35						
			DE...43		43						
			DE...63		63						
			DE...28S		28						
			DE...35S		35						
			DE...43S		43						
			DE...28D		28						
			DE...35D		35						
			DE...43D		43						
			DE...63D		63						
			DS								
	DSS35	35									
	DSS43	43									
	DSS63	63									
	DSS43S	43									
	DSB28	28									
	DSB35	35									
	DSB43	43									
	DSD28	28									
	DSD35	35									
	DSD43	43									
DSC		DSC43		43	Cold Draw	■	++	■		■	
		DSC43		43							
DBN		DBN22		22	Cold Draw	■	++	■		■	
		DBN28		28							
		DBN35		35							
		DBN43		43							
DMS		DMS63		63	Cold Draw	■	++	■		■	
DSE		DSE28		28	Cold Draw	■	++	■		■	
		DSE35		35							
		DSE43		43							
		DSE63		63							

Reported data must be verified according to the application.

* The maximum value is defined by the application. For more information, please contact our technical department.

■ standard

X steel
A stainless steel
aluminum

B stroke in both directions
BM stroke in both directions with driving disc



Material		Stroke direction		Snap	Locking closed position	Damping closed position	Max. load capacity per pair [N]		Max. rail length [mm]	Max. stroke [mm]	Max. extension speed* [m/s]	Rigidity (deflection)	Operating temperature [°C]
X	A	B	BM				C _{0rad}	C _{0ax}					
			■				5934	4154	770	394	0,8	+++	-20°C/+170°C
			■				15736	11014	1170	601	0,8		
			■				26520	18564	1490	759	0,8		
			■				48596	34018	1970	1013	0,8		
			■				88494	61946	1970	1013	0,8		
			■				1348	546	770	788	0,8		
			■				2338	1074	1170	1202	0,8		
			■				3816	1586	1490	1518	0,8		
			■				6182	2868	1970	2026	0,8		
			■				14396	6124	1970	2026	0,8		
					■		2100	758	1170	1186	0,8		
					■		3540	1574	1490	1510	0,8		
					■		5964	2522	1970	2066	0,8		
						■	2014	856	1170	1216	0,8		
						■	3460	1534	1490	1503	0,8		
						■	5784	2484	1970	2011	0,8		
						■	15512	6514	1970	1962	0,8		
						■	7524	3830	1970	1923	0,8		
						■	4480	-	1490	1518	0,8		
						■	7016	-	1730	1758	0,8		
						■	9816	-	1970	2026	0,8		
						■	25664	-	1970	2026	0,8		
						■	10208	-	1970	2026	0,8		
					■		4480	-	1490	1518	0,8		
					■		7016	-	1730	1758	0,8		
					■		9816	-	1970	2026	0,8		
						■	5162	-	1490	1446	0,8		
						■	9736	-	1730	1630	0,8		
						■	11660	-	1970	1916	0,8		
						■	38018	-	1970	1758	0,8		
						■	11058	4150	1970	2028	0,8		
							562	472	770	788	0,8		
							1244	1074	1170	1202	0,8		
							1334	1120	1490	1518	0,8		
							2662	2558	1970	2026	0,8		
						■	39624	-	2210	2266	0,8		
							1702	-	1170	1803	0,8		
							3182	-	1490	2277	0,8		
							5012	-	1970	3039	0,8		
							11344	-	1970	3039	0,8		

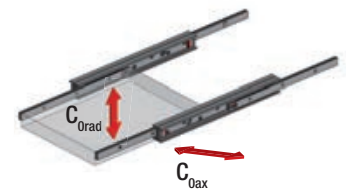

T
R

H
R

T
L
R

L
R

Technical features overview



Reference			Product name	Extraction	Size	Profile		Self alignment	Slider		Steel
Product Family	Product	Section				Type	Hardened raceways		Balls	Rollers	
Hegra Rail		HTT		HTT030	 60 % to 66 %	30	Machined		+	●	●
				HTT040		40					
				HTT050		50					
		HVC		HVC045	 100 %	45	Bended sheetmetal & cold drawn		++	●	●
				HVC050		50					
				HVC058		58					
				HVC075		75					
		H1C*1		H1C075	 150%	75	Machined, cold drawn & bended sheetmetal		++	●	●
		H1T*1		H1T060	 150 % to 200 %	60	Machined & cold drawn		++	●	●
				H1T080		80					
				H1T100		100					
				H1T150		150					
		H2H		H2H080	 150 % to 200 %	80			++	●	●
		LTH		LTH30	 100 %	30	Cold drawn		++	●	●
				LTH45		45					
				LTH30S		30					
				LTH45S		45					
		HGT		HGT060	 100 %	60	Machined & cold drawn		++	●	●
				HGT080		80					
HGT100				100							
HGT120				120							
HGT150				150							
HGT200				200							
HGT240				250							
	LTF		LTF44	 100 %	44	Cold drawn		++	●	●	
	HGS		HGS060	 100 %	60	Machined		++	●	●	

Reported data must be verified according to the application.

In many cases, special designs or alternative surface coatings are possible. For more information, please contact our technical department.

*1 The over extension corresponds to 150 % stroke (1=150 % extraction). For a 200 % stroke (2=200 % extraction) please contact our technical department.

*2 Different temperature ranges from -30 °C to +250 °C, This must be verified according to the application.

*3 The load capacity for aluminum is 40 % and for stainless steel 60 % of the stated values, if available in this material variant.

*4 Different stainless steels, such as the «electropolishing» option, are available. For more information, please contact our technical department.

*5 The availability of locking systems depends on the system length and varies per product group. For more information, please contact our technical department.

*6 The operating temperature is maximum +50°C if damping is used. For more information, please contact our technical department.

*7 The maximum value is defined by the application. For more information, please contact our technical department.

- feasible
- ▲ only to length 1000
- standard

Material		Stroke direction			Snap			Locking*5			Damp- ing	Max. load capacity per pair [N]		Max. rail length [mm]	Max. stroke [mm]	Max. extension speed*7 [m/s]	Rigidity (deflec- tion)	Operating tempera- ture*2*6 [°C]
X*4	A	B	BM	EG	EO	EB	VG	VO	VB	DG	C _{0rad} *3	C _{0ax}						
•	•	•		•	•	•				■	1200	on request	1000	660	0,8	+++	-20°C/+170°C	
				•	•	•				■	2550		1000	660				
				•	•	•	•	•	•	■	2900		1200	720				
											1200	on request	1200	1200	0,8	+	-20°C/+170°C	
							•	•	•	•	1500		1500	1500				
							•	•	•	•	2100		1500	1500				
							•	•	•	•	3300		2000	2000				
										•	1350	-	1500	2250	0,5	+	-20°C/+170°C	
										•	2600	-	1500	2250	0,5	++	-20°C/+170°C	
										•	3200	-	1500	2250				
										•	5500	-	2000	3000				
										•	7500	-	2000	3000				
										•	on request	-	2000	3000	0,5	++	-20°C/+170°C	
											1470	on request	1200	1215	0,5	++	-20°C/+170°C	
											3346		1500	1522				
										•	1498		1200	1217				
										•	3084		1500	1522				
											5500	on request	1500	1500	0,5	+++	-20°C/+170°C	
				▲	▲	▲				•	9350		2000	2000				
										•	11000		2000	2000				
										•	11800		2000	2000				
										•	13900		2000	2000				
										•	17500		2300	2300				
										•	20000		2000	2000				
											1296		-	1010				1010
											1400	-	1000	1000	0,5	+++	-20°C/+170°C	

X steel
 stainless steel
 A aluminum

B stroke in both directions
 BM stroke in both directions
 with driving disc

EG snap on closed position
 EO snap on opened position
 EB snap on both positions

VG locking closed position
 VO locking opened position
 VB locking both positions

DG damping closed position

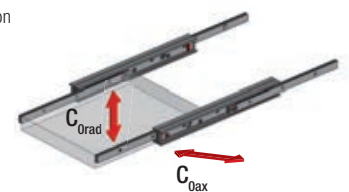

T
R

H
R

T
L
R

L
R

Technical features overview



Reference			Product name	Extraction	Size	Profile		Self alignment	Slider			
Product Family	Product	Section				Type	Rollon NOX hardening*1		Balls	Rollers	Steel	
Telerace		TLR		TLR18	 100%	18	Cold Draw	■	+++		■	■
				TLR28		28						
				TLR43		43						
		TLQ		TLQ18FF	 80% A 120%	18	Cold Draw	■	+		■	■
				TLQ28		28						
				TLR43		43						
		TLN		TLN30	 100%	30	Formed Sheetmetal	■	+		■	■
				TLN40		40						
		TON		TON30	 80% A 120%	30	Formed Sheetmetal	■	+		■	■
				TON40		40						
		TLAX		TLAX26	 100%	26	Formed Sheetmetal		+		■	
				TLAX40		40						
		TQAX		TQAX26	 80% A 120%	26	Formed Sheetmetal		+		■	
				TQAX40		40						

Reported data must be verified according to the application.

*1 High dept nitride hardening treatment and oxidation.

*2 Also available in TLN.HP version with greater load capacity.

*3 The maximum value is defined by the application. For more information, please contact our technical department.

■ standard

X steel

A stainless steel

A aluminum

B

BM

stroke in both directions

stroke in both directions with driving disc

Reference			Product name	Extraction	Size	Profile		Self alignment	Slider			
Product Family	Product	Section				Type	Hardened raceways		Balls	Rollers	Steel	
Light Rail		LPS		LPS38	 50%	38	Formed Sheetmetal		++	■		■
		LFS		LFS46	 100%	46	Formed Sheetmetal		++	■		■
				LFS57		57						
				LFS58		58						
				LFS70		70						
	LFX		LFX27	 100%	27	Formed Sheetmetal		++	■			

Reported data must be verified according to the application.

* The maximum value is defined by the application. For more information, please contact our technical department.

■ standard

X steel

A stainless steel

A aluminum

B

BM

stroke in both directions

stroke in both directions with driving disc

Material		Stroke direction		Suitable for variable stroke cycles	Suitable for vertical stroke	Damping closed position	Max. load capacity per pair [N]		Max. rail length [mm]	Max. stroke [mm]	Max. extension speed* ³ [m/s]	Rigidity (deflection)	Operating temperature [°C]
X	A	B	BM				C _{Orad}	C _{Oax}					
				■		■	1304	-	770	770	1,0	++++	-20 °C/+110 °C
							3264	-	1490	1500			
							7672	-	1970	1980			
				■	■	■	946	426	770	770	1,0	+++	-20 °C/+110 °C
							2058	808	1490	1490			
							4978	1784	1970	1970			
				■		■	1776* ²	-	1490	1500	1,0	++++	-20 °C/+80 °C
							3648* ²	-	1970	1980			
				■	■	■	1362	476	1490	1490	1,0	+++	-20 °C/+80 °C
							2592	906	1970	1970			
■				■		■	1330	-	1200	1200	1,0	++++	-20 °C/+80 °C
							2422	-	1600	1600			
■				■	■	■	1008	352	1200	1200	1,0	+++	-20 °C/+80 °C
							2170	760	1600	1600			

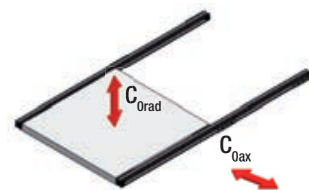

Material		Stroke direction		Snap closed position	Locking	Damping closed position	Max. load capacity per pair [N]		Max. rail length [mm]	Max. stroke [mm]	Max. extension speed* [m/s]	Rigidity (deflection)	Operating temperature [°C]
X	A	B	BM				C _{Orad}	C _{Oax}					
							350	100	473	373	0,5	+	+10 °C/+40 °C
						■	400	100	600	610	0,5	+	+10 °C/+40 °C
						■	800	160	750	800			
				■		■	600	-	550	584			
						■	2000	300	1100	1100			
■							350	50	550	576	0,5	+	-30 °C/+200 °C

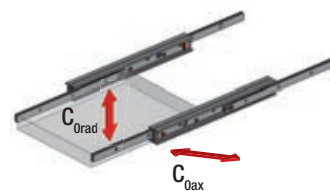

T R

H R

T L R

L R

ROLLON[®]
BY TIMKEN

Telescopic Rail



Product explanation



➤ Telescopic Rail: Seven models with full and partial extension



Fig. 1

The Telescopic Rail product line is made up of seven models with full and partial extension and various cross-sections and intermediate elements in S-shape, I-beam or square. High loads in combination with cost-efficiency and free movement have long been the outstanding properties of the Telescopic Rail product line.

The most important characteristics:

- High load capacity with low deflection
- Rigid intermediate elements
- Standardized hole locations
- Zero-play running even with maximum load
- Space saving design
- High reliability

Preferred areas of application of the Telescopic Rail product family:

- Railcars (e. g. maintenance and battery extensions, doors)
- Construction and machine technology (e.g., housings and doors)
- Logistics (e.g., extensions for containers or gripper movements)
- Automotive technology
- Packaging machines
- Beverage industry
- Special machines

ASN

Partially extending telescopic rail consisting of a guide rail and a slider. This compact and simple design allows for very high load capacities. When the guide rail is mounted to a structure a very high rigidity system is created.



Fig. 2

DS

Fully extending telescopic rail consisting of a fixed guide rail, an identical moving guide rail, and an S-shaped intermediate element. This has a high moment of inertia and high rigidity in a slim size. This results in a high loading capacity with low deflection in the extended state.

The DS series is available in three different designs: DSS version with single direction stroke, DSB version with single direction stroke and locking capability in the extended state, and DSD version with double direction stroke. DS...S version available with reinforced and damped stainless steel end stops.



Fig. 3

DSE

Telescopic rail with a 150% extension of its length, made by four elements. It has a high rigidity, thanks to the intermediate elements with a high moment of inertia, in a streamlined shape.

This results in a high load capacity, with reduced bending even when the telescopic guide is fully extended.



Fig. 4

DSC

Fully extending telescopic rail consisting of a compact and flexurally rigid intermediate element that connects two different sized guide rails with each other as a fixed and moving element.

This design makes it possible to reduce all components to the necessary size and length for achieving the full stroke. The DSC series features high rigidity and a high load capacity in a compact size. This results in an optimal combination of performance and weight reduction.



Fig. 5

DE

Fully extending telescopic rail consisting of two guide rails, which are mounted on an I-beam profile to form the intermediate element, one moveable slider and one fixed slider which mounts onto the structure. The square cross-section allows a compact size with high load capacities and low deflection, especially with radial loading. Also available with a double stroke design, which includes an eccentrically located driving disc for simultaneous movement. For double sided extensions, a dedicated DE...D version is available with a driving disc.

DE...S version available with reinforced and damped stainless steel end stops.



Fig. 6

DBN

Fully extending telescopic rail consisting of two guide rails, one which is fixed to a structure, and one which is moveable, and two sliders which are mounted together and form the intermediate element. The size is similar to the DE series and offers good protection from contamination of the ballcage.



Fig. 7

DMS

Heavy load telescopic consisting of elements from the ASN series and an extremely rigid I-beam profile as the intermediate element. This fully extending telescopic rail is used to accept very heavy loads with low deflection.



Fig. 8

Overview product cross sections

> Partial extension guides

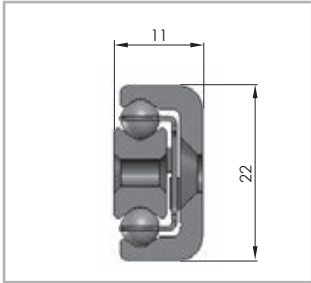

Fig. 9

ASN22

Load capacities p. TR-8

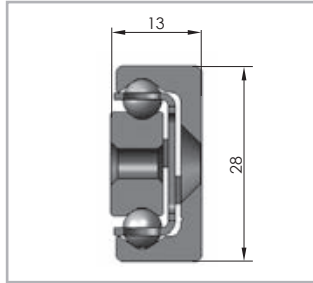

Fig. 10

ASN28

Load capacities p. TR-9

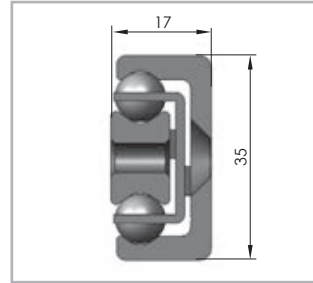

Fig. 11

ASN35

Load capacities p. TR-9

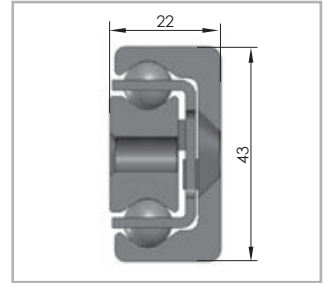

Fig. 12

ASN43

Load capacities p. TR-10

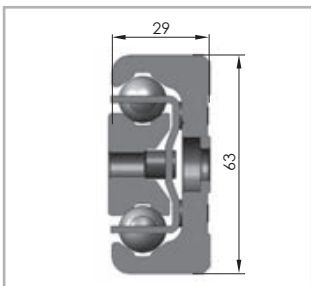

Fig. 13

ASN63

Load capacities p. TR-10

> Full extension guides

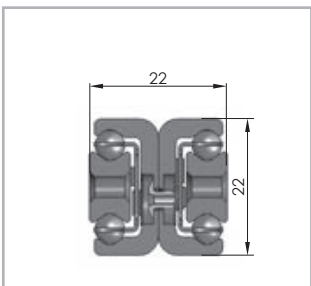

Fig. 14

DE22

Load capacities p. TR-23

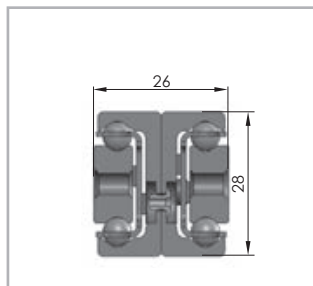

Fig. 15

DE28

Load capacities p. TR-23

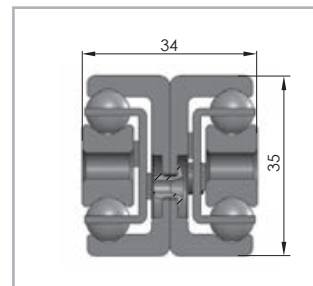

Fig. 16

DE35

Load capacities p. TR-24

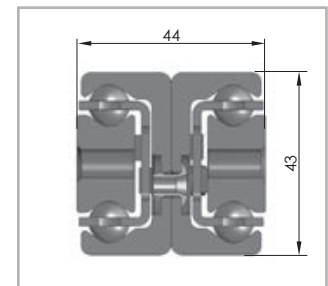

Fig. 17

DE43

Load capacities p. TR-24

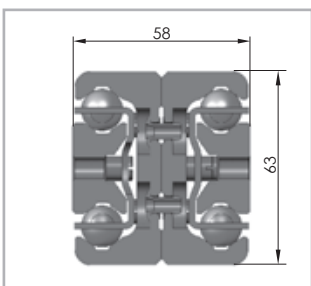

Fig. 18

DEF63

Load capacities p. TR-24

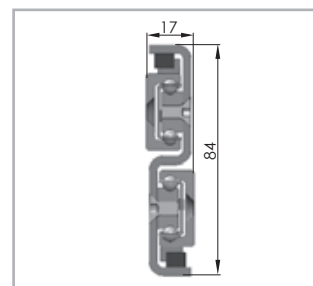

Fig. 19

DSS28

Load capacities p. TR-12

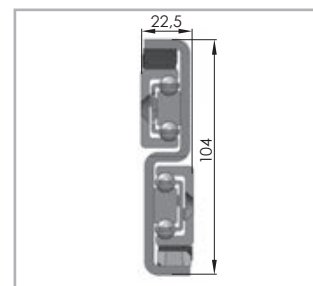

Fig. 20

DSS35

Load capacities p. TR-12

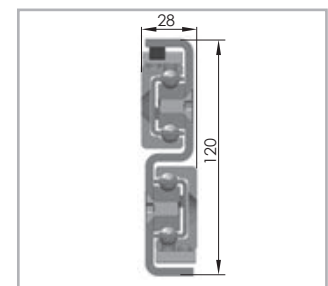

Fig. 21

DSS43

Load capacities p. TR-13

> Full extension guides

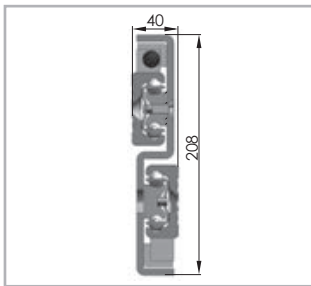

Fig. 22

DSS63

Load capacities p. TR-13

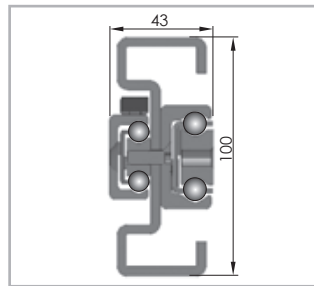

Fig. 23

DSC43

Load capacities p. TR-21

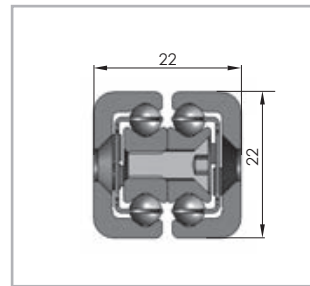

Fig. 24

DBN22

Load capacities p. TR-32

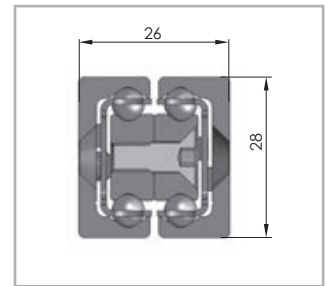

Fig. 25

DBN28

Load capacities p. TR-32

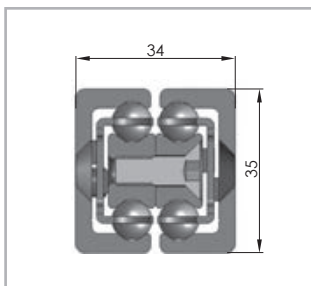

Fig. 26

DBN35

Load capacities p. TR-33

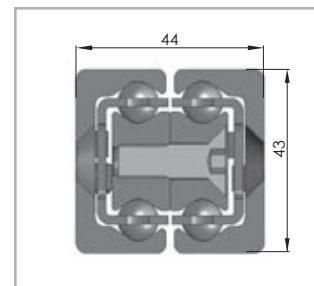

Fig. 27

DBN43

Load capacities p. TR-33

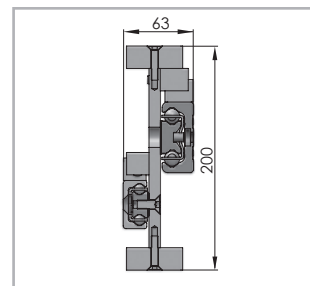

Fig. 28

DMS63

Load capacities p. TR-34

> Overextending guides

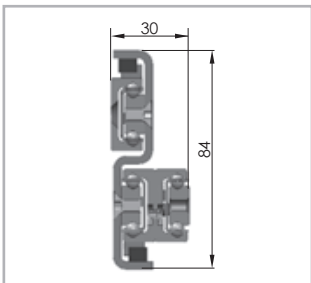

Fig. 29

DSE28

Load capacities p. TR-19

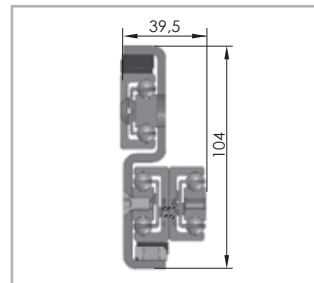

Fig. 30

DSE35

Load capacities p. TR-19

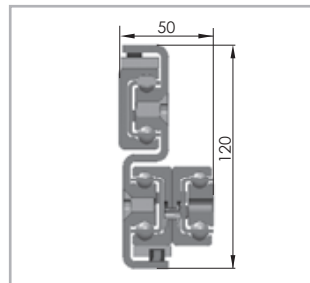

Fig. 31

DSE43

Load capacities p. TR-20

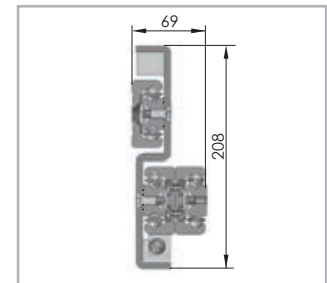

Fig. 32

DSE63

Load capacities p. TR-20

Technical data

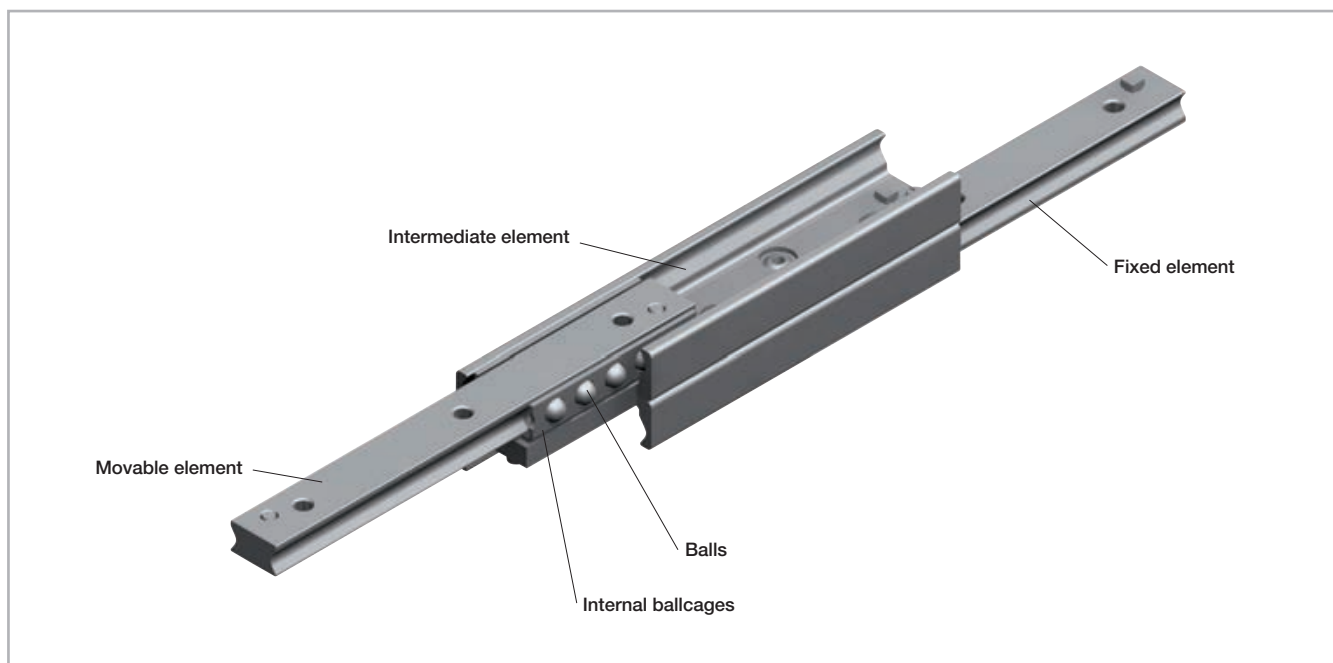

Fig. 33

Performance characteristics:

- Available sizes ASN / DE: 22, 28, 35, 43, 63
- Available sizes DS: 28, 35, 43, 63
- Available sizes DSE: 28, 35, 43, 63
- Available sizes DSC: 43
- Available sizes DBN: 22, 28, 35, 43
- Available size DMS: 63
- Induction hardened raceways
- Rails and sliders made of cold-drawn roller bearing carbon steel
- Balls made of hardened roller bearing carbon steel
- Max. operating speed: 0.8 m/s (31.5 in/s)
(depending on application)
- DE...S and DSS...S temperature range: -20°C to +50°C (-4°F to +122°F)
- ASN, DE, DBN, temperature range: -20 °C to +170 °C (-4 °F to +338 °F), DS, DSE, DSC and DMS: -20 °C to +80 °C (-4 °F to +176 °F)
- Electrolytic galvanised as per ISO 2081, increased anticorrosive protection on request (see pg. TR-45 Anticorrosive protection)

Remarks:

- All load capacity data are based on a pair of telescopic rails except the value M_x of ASN series (see pag. TR-8, TR-9, TR-10)
- Horizontal movement installation is recommended
- Vertical movement installation on request
- External end stops are recommended
- Double-sided stroke in ASN, DSD, DE, DBN series (DMS on request)
- Custom strokes on request
- All load capacity data is based on continuous operation
- Calculation of the service life is based exclusively on the loaded rows of balls
- For models DMS, DSB, and DSE, please observe right or left side use
- Fixing screws of property class 10.9 must be used for all telescopic rails
- Internal stops are used to stop the unloaded slider and the ball cage. Please use external stops as end stops for a loaded system

Dimensions and load capacity



> ASN

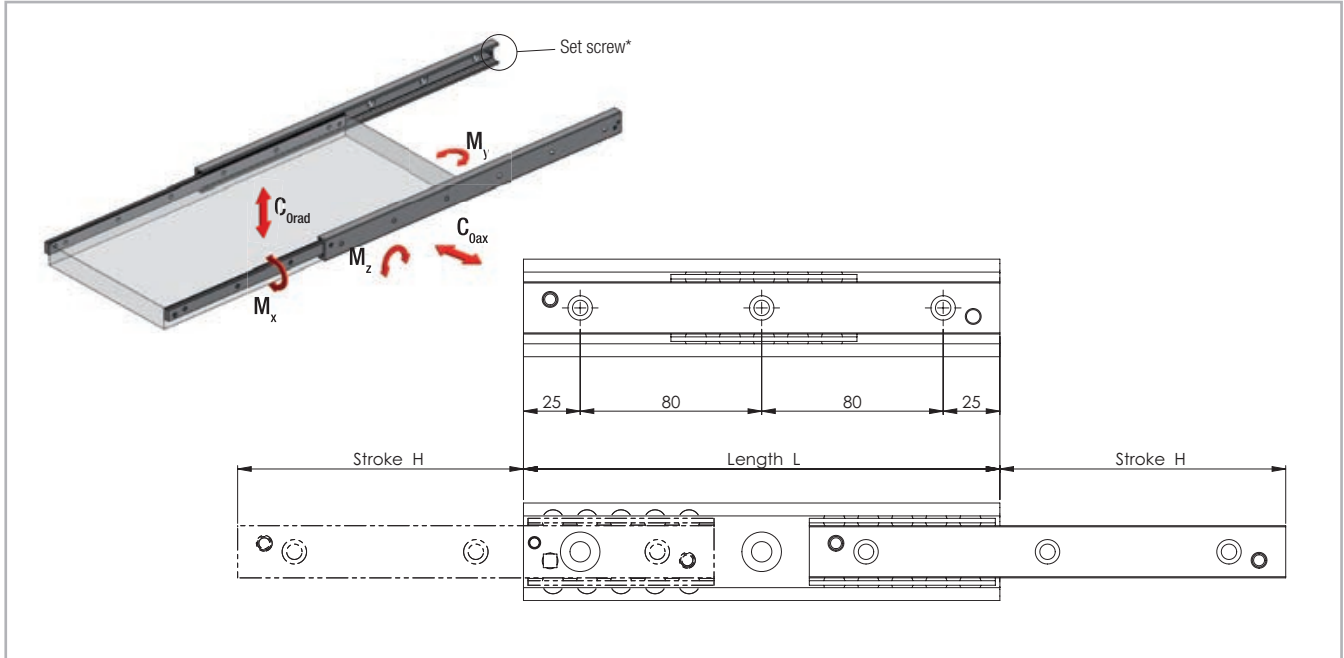

* Remove the set screw to reach all the fixing holes. See also assembly instructions on page TR-45f.

Fig. 34

Type	Size	Length L [mm]	Stroke H [mm]	Load capacity and moments for a pair of rails					No. of holes
				C_{0rad} [N]	C_{0ax} [N]	M_x^* [Nm]	M_y [Nm]	M_z [Nm]	
ASN	22	130	76	626	438	5.7	20	30	2
		210	111	1430	1002	10.7	72	102	3
		290	154	1988	1392	14.9	138	198	4
		370	196	2556	1790	19	226	324	5
		450	231	3402	2380	24	360	516	6
		530	274	3958	2770	28.2	496	710	7
		610	316	4524	3168	32.3	654	934	8
		690	351	5378	3764	37.3	872	1246	9
		770	394	5934	4154	41.5	1078	1538	10

* The value M_x refers to a single rail

Tab. 1

Type	Size	Length L [mm]	Stroke H [mm]	Load capacity and moments for a pair of rails					No. of holes
				C_{0rad} [N]	C_{0ax} [N]	M_x^* [Nm]	M_y [Nm]	M_z [Nm]	
ASN	28	130	74	1226	858	15.3	40	56	2
		210	116	2232	1562	26.1	114	164	3
		290	148	3868	2708	39.6	264	376	4
		370	190	4890	3422	50.4	426	610	5
		450	232	5910	4138	61.2	628	898	6
		530	274	6932	4852	72	870	1242	7
		610	316	7952	5566	82.8	1150	1642	8
		690	358	8974	6282	93.6	1470	2100	9
		770	400	9994	6996	104.4	1828	2612	10
		850	433	11656	8160	117.9	2330	3330	11
		930	475	12676	8872	128.7	2778	3968	12
		1010	517	13696	9586	139.5	3262	4660	13
		1090	559	14716	10300	150.3	3788	5410	14
1170	601	15736	11014	161.1	4350	6216	15		
ASN	35	210	127	2130	1492	29.4	114	164	3
		290	159	4120	2884	46.9	292	416	4
		370	203	5276	3694	59.9	476	680	5
		450	247	6434	4504	73	708	1010	6
		530	279	8564	5994	90.4	1086	1550	7
		610	323	9716	6802	103.5	1422	2030	8
		690	367	10870	7608	116.6	1804	2576	9
		770	399	13042	9130	134	2382	3404	10
		850	443	14190	9932	147.1	2870	4100	11
		930	487	15338	10736	160.2	3404	4862	12
		1010	519	17530	12272	177.6	4184	5978	13
		1090	563	18674	13072	190.7	4824	6890	14
		1170	607	19818	13874	203.8	5508	7868	15
1250	639	22024	15416	221.2	6490	9272	16		
1330	683	23164	16214	234.3	7280	10400	17		
1410	727	24306	17014	247.4	8116	11594	18		
1490	759	26520	18564	264.8	9300	13286	19		

* The value M_x refers to a single rail

Tab. 2

4 Dimensions and load capacity

Type	Size	Length L [mm]	Stroke H [mm]	Load capacity and moments for a pair of rails					No. of holes	
				C_{rad} [N]	C_{Oax} [N]	M_x^* [Nm]	M_y [Nm]	M_z [Nm]		
ASN	43	210	123	3190	2234	60.6	168	240	3	
		290	158	5744	4020	93.8	402	576	4	
		370	208	6754	4728	115.9	616	880	5	
		450	243	9380	6566	149.2	1018	1456	6	
		530	278	12078	8454	182.4	1524	2176	7	
		610	313	14822	10376	215.6	2128	3042	8	
		690	363	15726	11008	237.8	2588	3698	9	
		770	398	18464	12926	271	3362	4804	10	
		850	433	21230	14862	304.2	4238	6054	11	
		930	483	22108	15476	326.4	4878	6968	12	
		1010	518	24868	17408	359.6	5922	8460	13	
		1090	568	25754	18028	381.8	6674	9534	14	
		1170	603	28508	19956	415	7886	11266	15	
		1250	638	31276	21894	448.2	9198	13142	16	
		1330	688	32150	22504	470.4	10130	14472	17	
		1410	723	34912	24438	503.6	11612	16590	18	
		1490	758	37690	26382	536.8	13196	18850	19	
		1570	793	40476	28334	570.1	14880	21256	20	
		1650	843	41322	28926	592.2	16058	22940	21	
		1730	878	44104	30872	625.5	17912	25588	22	
		1810	928	44958	31472	647.6	19202	27432	23	
		1890	963	47734	33414	680.8	21224	30320	24	
		1970	1013	48596	34018	703	22628	32324	25	
		ASN	63	610	333	21182	14828	474	3106	4438
690	373			25068	17548	547.5	4144	5920	9	
770	413			28978	20284	621	5332	7616	10	
850	453			32904	23032	694.5	6668	9526	11	
930	493			36842	25790	768	8154	11648	12	
1010	533			40790	28554	841.4	9788	13984	13	
1090	573			44746	31322	914.9	11574	16534	14	
1170	613			48708	34096	988.4	13508	19296	15	
1250	653			52674	36872	1061.9	15590	22272	16	
1330	693			56644	39650	1135.4	17824	25462	17	
1410	733			60618	42432	1208.9	20204	28864	18	
1490	773			64594	45216	1282.4	22736	32480	19	
1570	813			68574	48002	1355.9	25416	36310	20	
1650	853			72554	50788	1429.4	28246	40352	21	
1730	893			76536	53576	1502.8	31226	44608	22	
1810	933			80522	56364	1576.3	34354	49078	23	
1890	973			84506	59154	1649.8	37632	53760	24	
1970	1013	88494	61946	1723.3	41060	58656	25			

Tab. 3

* The value M_x refers to a single rail

> ASN

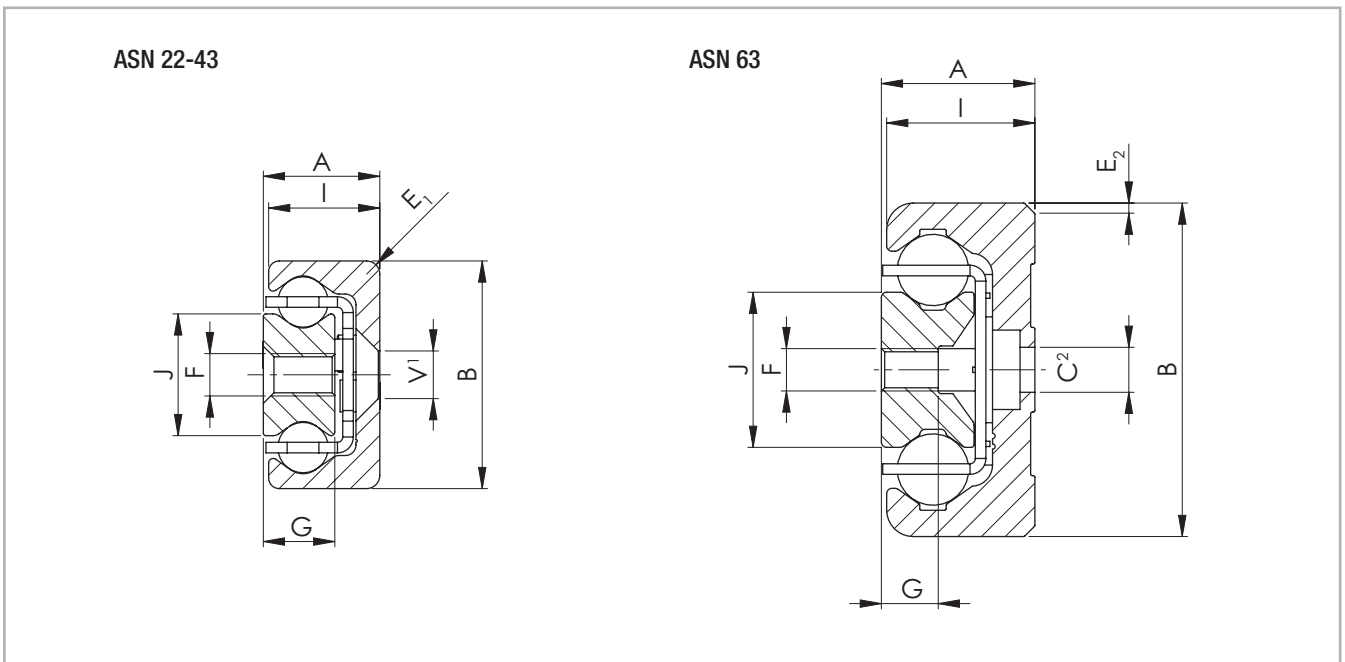

Fig. 35

¹ Fixing holes (V) for countersunk head screws according to DIN 7991

² Fixing holes (C) for socket cap screws according to DIN 7984. Alternative fixing with Torx® screws in special design with low head (on request)

Type	Size	Cross-section										Weight per single guide [kg/m]
		A [mm]	B [mm]	I [mm]	J [mm]	G [mm]	E ₁ [mm]	E ₂ [°]	V	C	F	
ASN	22	11	22	10.25	11.3	6.5	3	-	M4	-	M4	1.32
	28	13	28	12.25	15	7.5	1	-	M5	-	M5	2.02
	35	17	35	16	15.8	10	2	-	M6	-	M6	3.05
	43	22	43	21	23	13.5	2.5	-	M8	-	M8	5.25
	63	29	63	28	29.3	10.5	-	2 x 45	-	M8	M8	10.30

Tab. 4

> DSS

DSS with one-sided extension (single stroke)

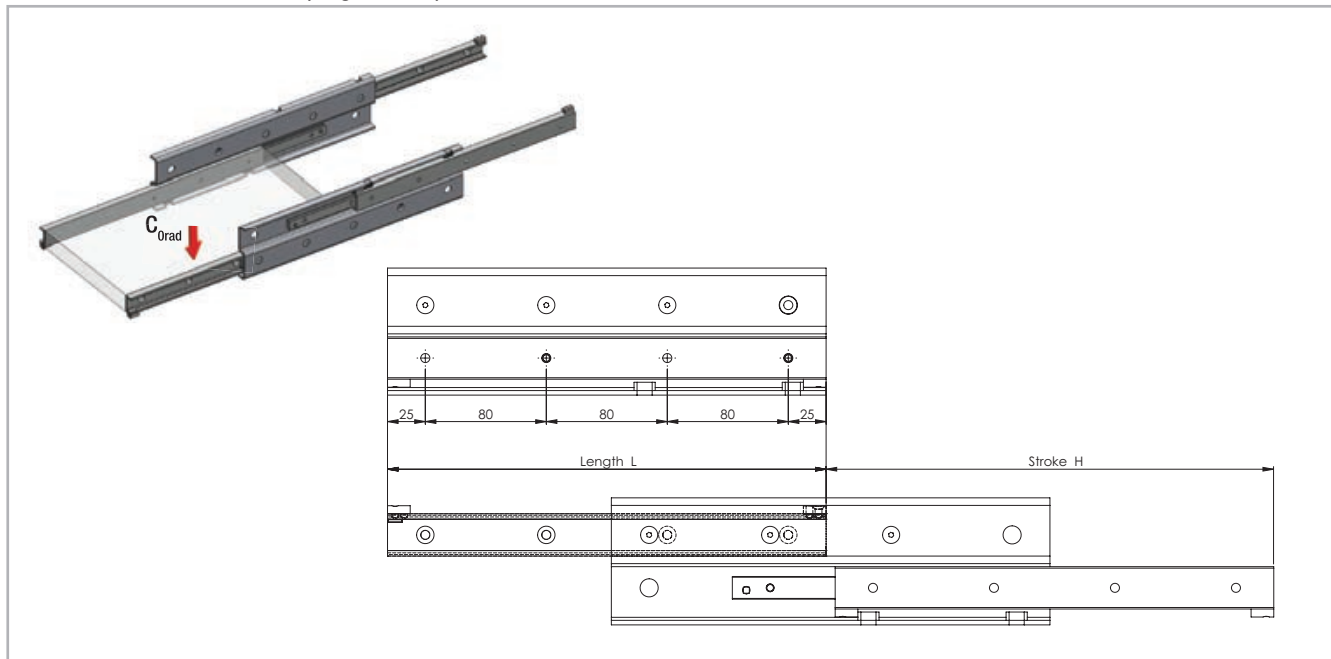

Fig. 36

Type	Size	Length L [mm]	Stroke H [mm]	Load capacity for a pair of rails C_{Orad} [N]	Accessible holes / total
DSS	28	290	296	1140	3 / 4
		370	380	1538	4 / 5
		450	464	1938	4 / 6
		530	548	2340	6 / 7
		610	630	2752	6 / 8
		690	714	3154	7 / 9
		770	798	3556	7 / 10
		850	864	4222	9 / 11
		930	950	4480	9 / 12
		1010	1034	4108	10 / 13
		1090	1118	3792	10 / 14
		1170	1202	3522	12 / 15
		1250	1266	3390	12 / 16
		1330	1350	3172	13 / 17
1410	1434	2980	13 / 18		
1490	1518	2810	15 / 19		

Tab. 5

Type	Size	Length L [mm]	Stroke H [mm]	Load capacity for a pair of rails C_{Orad} [N]	Accessible holes / total
DSS	35	450	494	2500	5 / 6
		530	558	3370	6 / 7
		610	646	3816	6 / 8
		690	734	4264	7 / 9
		770	798	5158	8 / 10
		850	886	5602	9 / 11
		930	974	6048	9 / 12
		1010	1038	6952	10 / 13
		1090	1126	7016	11 / 14
		1170	1214	6480	12 / 15
		1250	1278	6242	12 / 16
		1330	1366	5814	13 / 17
		1410	1454	5442	14 / 18
		1490	1518	5272	15 / 19
		1570	1606	4964	15 / 20
		1650	1694	4690	16 / 21
		1730	1758	4564	17 / 22

Tab. 6

Type	Size	Length L [mm]	Stroke H [mm]	Load capacity for a pair of rails C_{0rad} [N]	Accessible holes / total
DSS	43	530	556	4122	6 / 7
		610	626	5206	6 / 8
		690	726	5550	7 / 9
		770	796	6638	7 / 10
		850	866	7746	9 / 11
		930	966	8072	9 / 12
		1010	1036	9180	10 / 13
		1090	1106	10208	10 / 14
		1170	1206	9220	12 / 15
		1250	1276	8796	12 / 16
		1330	1376	8054	13 / 17
		1410	1446	7728	14 / 18
		1490	1516	7426	15 / 19
		1570	1616	6890	15 / 20
		1650	1686	6650	16 / 21
		1730	1756	6426	17 / 22
		1810	1856	6022	18 / 23
1890	1926	5838	18 / 24		
1970	2026	5500	19 / 25		

Tab. 7

Type	Size	Length L [mm]	Stroke H [mm]	Load capacity for a pair of rails C_{0rad} [N]	Accessible holes / total
DSS	63	610	666	7004	6 / 8
		690	746	8504	8 / 9
		770	826	10024	8 / 10
		850	906	11560	9 / 11
		930	986	13104	9 / 12
		1010	1066	14658	11 / 13
		1090	1146	16218	11 / 14
		1170	1226	17784	12 / 15
		1250	1306	19354	12 / 16
		1330	1386	20928	14 / 17
		1410	1466	22504	14 / 18
		1490	1546	24082	15 / 19
		1570	1626	25664	15 / 20
		1650	1706	24728	17 / 21
		1730	1786	23654	17 / 22
		1810	1866	22668	18 / 23
		1890	1946	21762	18 / 24
1970	2026	20926	20 / 25		

Tab. 8

> DSS

DSS with one-sided extension (single stroke)

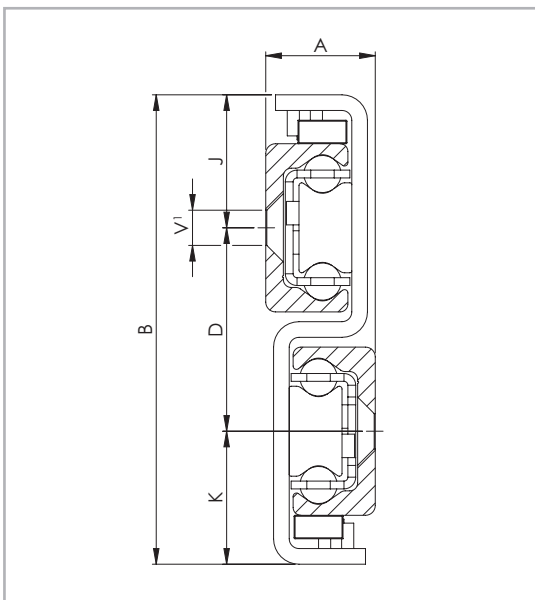

¹ Fixing holes (V) for countersunk head screws according to DIN 7991 Fig. 37

Type	Size	Cross-section						Weight per single guide [kg/m]
		A [mm]	B [mm]	K [mm]	D [mm]	J [mm]	V	
DSS	28	17	84	24.5	35	24.5	M5	6.40
	35	22.5	104	30.5	43	30.5	M6	10.10
	43	28	120	34	52	34	M8	14.60
	63	40	208	64	80	64	M10	32.60

Tab. 9

> DSS...S

... S-Version with reinforced and damped stainless steel limit blocks

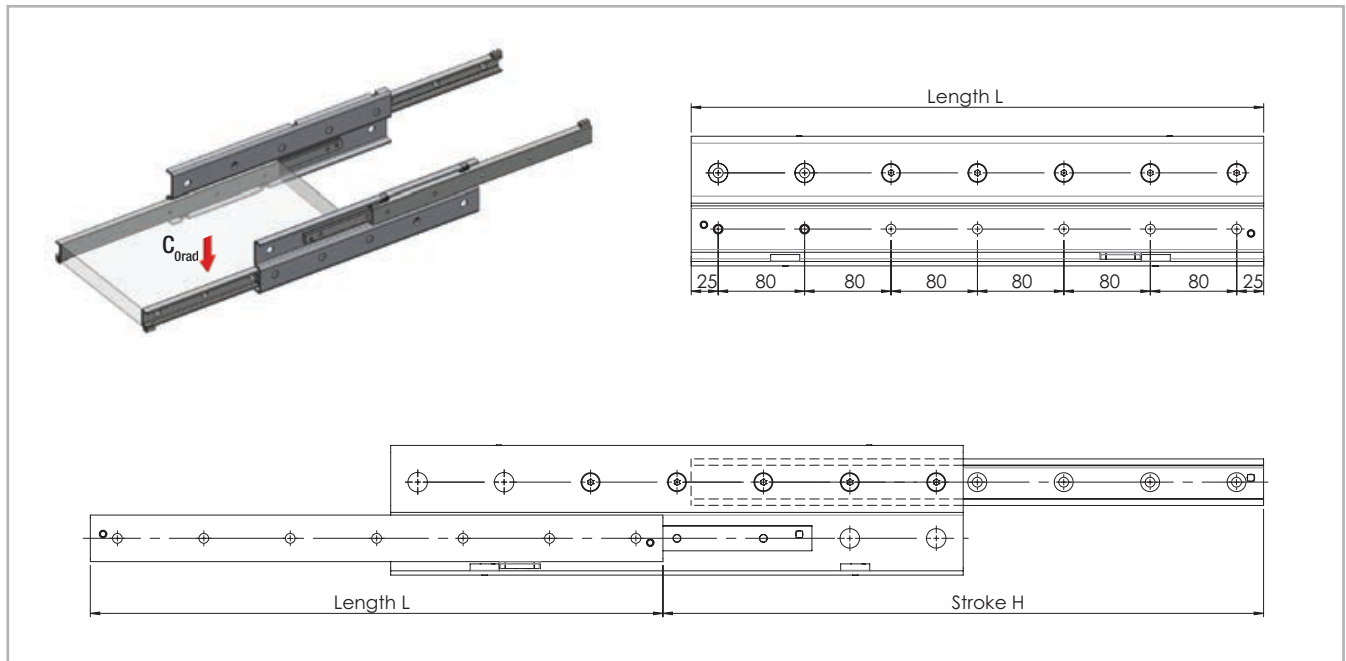

Fig. 38

Type	Size	Length L [mm]	Stroke H [mm]	Load capacity for a pair of rails C_{Orad} [N]	Accessible holes / total
DSS...S	43	530	556	4122	6 / 7
		610	626	5206	6 / 8
		690	726	5550	7 / 9
		770	796	6638	7 / 10
		850	866	7746	9 / 11
		930	966	8072	9 / 12
		1010	1036	9180	10 / 13
		1090	1106	10208	10 / 14
		1170	1206	9220	12 / 15
		1250	1276	8796	12 / 16
		1330	1376	8054	13 / 17
		1410	1446	7728	14 / 18
		1490	1516	7426	15 / 19
		1570	1616	6890	15 / 20
		1650	1686	6650	16 / 21
		1730	1756	6426	17 / 22
		1810	1856	6022	18 / 23
1890	1926	5838	18 / 24		
1970	2026	5500	19 / 25		

Tab. 10

> DSS...S

...S version with reinforced and damped stainless steel end stops

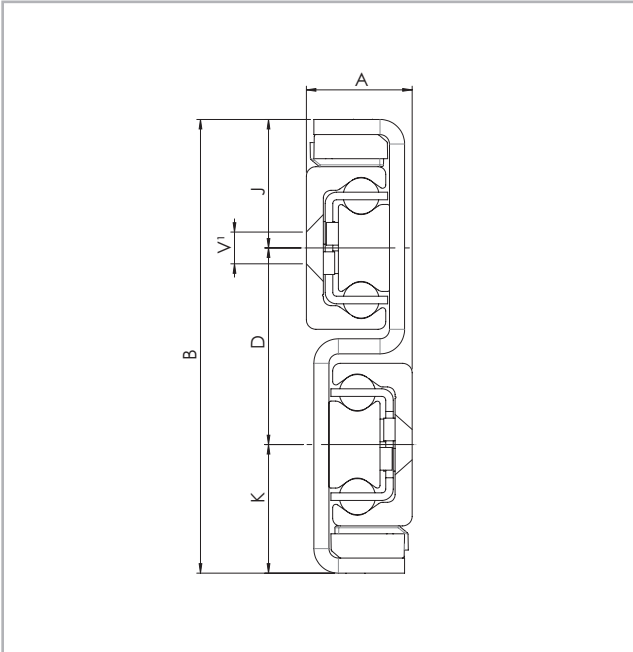

¹ Fixing holes (V) for countersunk head screws according to DIN 7991

Fig. 39

Type	Size	Cross-section						Weight per single guide [kg/m]
		A [mm]	B [mm]	K [mm]	D [mm]	J [mm]	V	
DSS...S	43	28	120	34	52	34	M8	14.60

Tab. 11

> DSB

B version with locking system for closed position

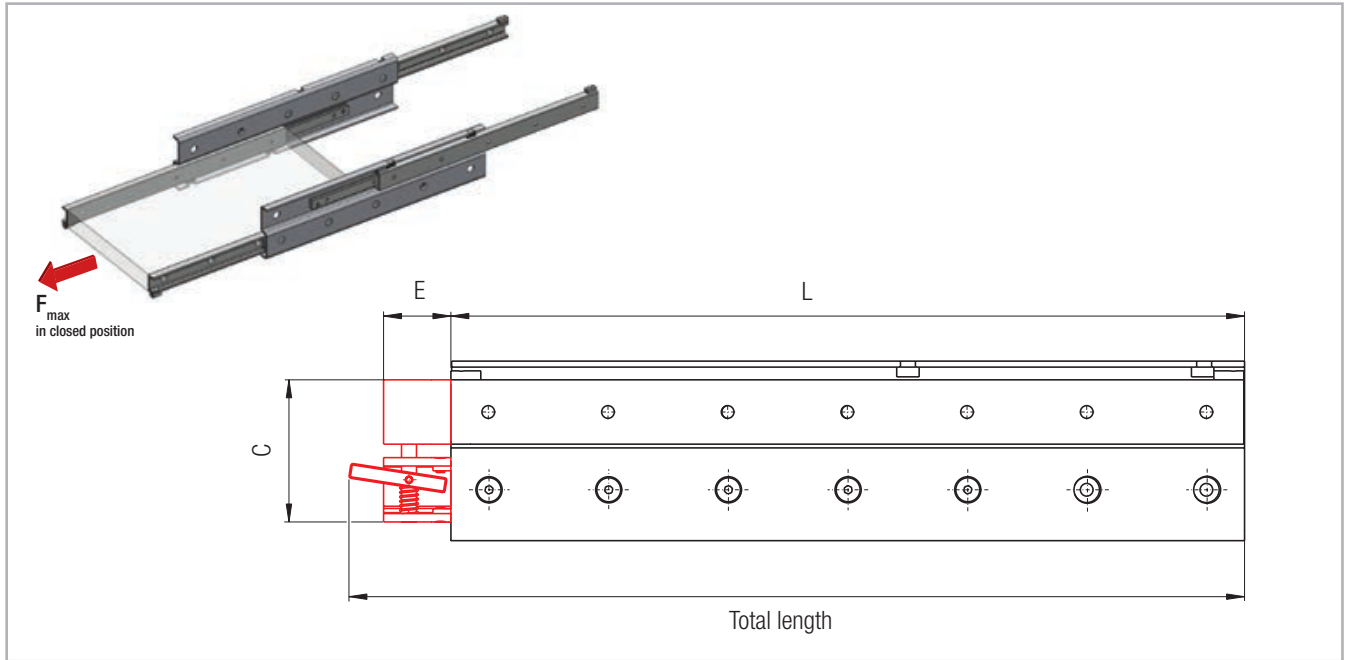

Fig. 40

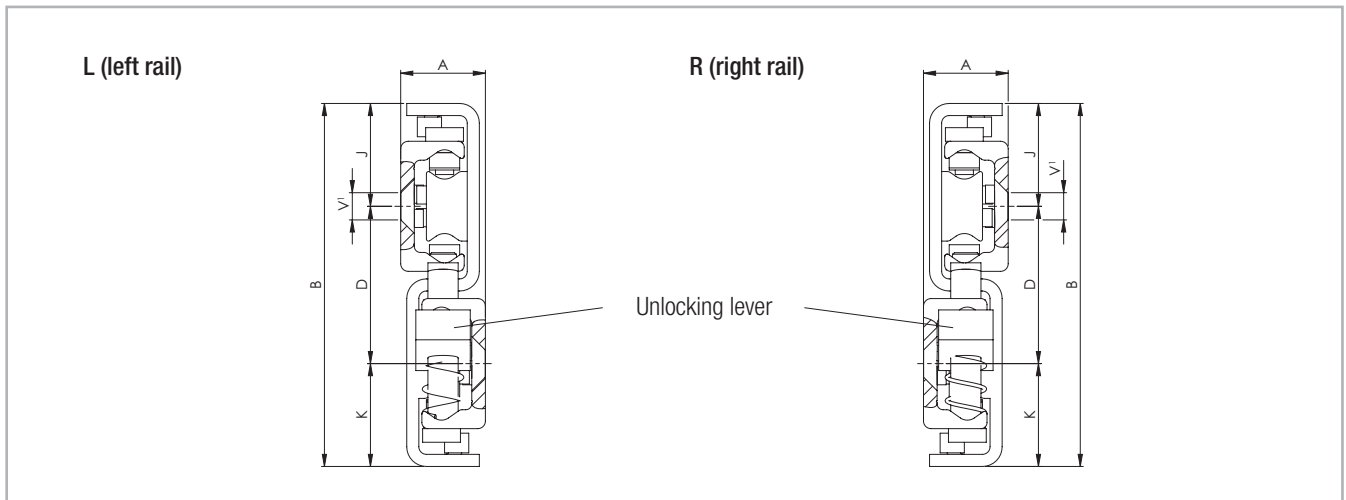

Fig. 41

¹ Fixing holes (V) for countersunk head screws according to DIN 7991

The DSB is built on the DSS design. The same load capacities, cross-sections and available rail lengths apply (see pg. TR-12ff). Data in Table 10 are based on the special features of the locking mechanism.

Please observe right or left installation for version DSB. The maximum load on the locking when closed is indicated by F_{max} .

Type	Size	L [mm]	Total length [mm]	C [mm]	E [mm]	F_{max}^{*2} [N]	Weight per single guide [kg/m]
DSB	28	from 290 to 1490*	L + 52	63	35	2460	6.51
	35	from 450 to 1730*	L + 53	78	33	3000	10.4
	43	from 530 to 1970*	L + 69	95	45	5630	14.98

* For available lengths, see pg. TR-12, tab. 5 and 7 (DSS)

*2 When using one lock

Tab. 12

> DSD

DSD with double direction stroke (double stroke)

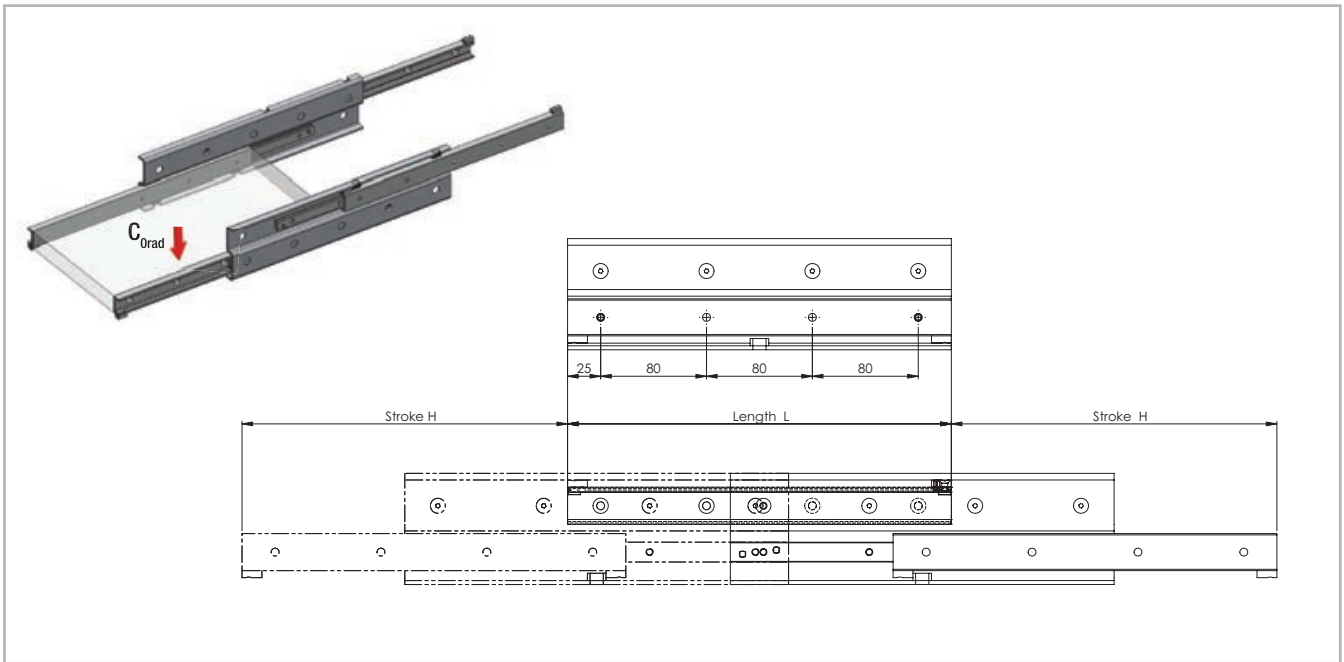

Fig. 42

Type	Size	Length L [mm]	Stroke H [mm]	Load capacity for a pair of rails C_{Orad} [N]	Accessible holes / total
DSD	28	290	246	1790	4 / 4
		370	326	2210	4 / 5
		450	406	2634	6 / 6
		530	486	3252	6 / 7
		610	566	3674	8 / 8
		690	646	4100	8 / 9
		770	726	4524	10 / 10
		850	806	4950	10 / 11
		930	886	5162	12 / 12
		1010	966	4714	12 / 13
		1090	1046	4336	14 / 14
		1170	1126	4016	14 / 15
		1250	1206	3740	16 / 16
		1330	1286	3498	16 / 17
1410	1366	3288	18 / 18		
1490	1446	3100	18 / 19		

Tab. 13

Type	Size	Length L [mm]	Stroke H [mm]	Load capacity for a pair of rails C_{Orad} [N]	Accessible holes / total
DSD	35	450	350	6050	4 / 6
		530	430	6382	6 / 7
		610	510	6762	6 / 8
		690	590	7600	8 / 9
		770	670	8016	8 / 10
		850	750	8446	10 / 11
		930	830	9292	10 / 12
		1010	910	9736	12 / 13
		1090	990	9160	12 / 14
		1170	1070	8404	14 / 15
		1250	1150	7764	14 / 16
		1330	1230	7214	16 / 17
		1410	1310	6738	16 / 18
		1490	1390	6320	18 / 19
		1570	1470	5950	18 / 20
		1650	1550	5622	20 / 21
		1730	1630	5328	20 / 22

Tab. 14

Type	Size	Length L [mm]	Stroke H [mm]	Load capacity for a pair of rails C_{Orad} [N]	Accessible holes / total
DSD	43	530	476	6036	6 / 7
		610	556	6530	8 / 8
		690	636	7562	8 / 9
		770	716	8594	10 / 10
		850	796	9094	10 / 11
		930	876	10126	12 / 12
		1010	956	11156	12 / 13
		1090	1036	11660	14 / 14
		1170	1116	10784	14 / 15
		1250	1196	10028	16 / 16
		1330	1276	9372	16 / 17
		1410	1356	8796	18 / 18
		1490	1436	8286	18 / 19
		1570	1516	7834	20 / 20
		1650	1596	7426	20 / 21
		1730	1676	7060	22 / 22
		1810	1756	6728	22 / 23
1890	1836	6426	24 / 24		
1970	1916	6150	24 / 25		

Tab. 15

Type	Size	Length L [mm]	Stroke H [mm]	Load capacity for a pair of rails C_{Orad} [N]	Accessible holes / total
DSD	63	610	398	23716	6 / 8
		690	478	24484	6 / 9
		770	558	25434	8 / 10
		850	638	26500	8 / 11
		930	718	27646	10 / 12
		1010	798	28848	10 / 13
		1090	878	30092	12 / 14
		1170	958	31368	12 / 15
		1250	1038	32668	14 / 16
		1330	1118	33988	14 / 17
		1410	1198	35322	16 / 18
		1490	1278	36670	16 / 19
		1570	1358	38018	18 / 20
		1650	1438	35538	18 / 21
		1730	1518	33360	20 / 22
		1810	1598	31436	20 / 23
		1890	1678	29720	22 / 24
1970	1758	28182	22 / 25		

Tab. 16

> DSD

DSD with double direction stroke (double stroke)

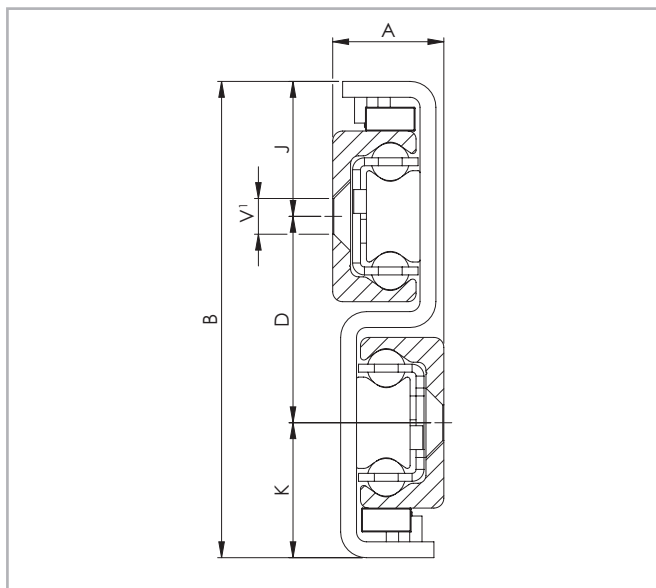

¹ Fixing holes (V) for countersunk head screws according to DIN 7991

Fig. 43

Type	Size	Cross-section						Weight per single guide [kg/m]
		A [mm]	B [mm]	K [mm]	D [mm]	J [mm]	V	
DSD	28	17	84	24.5	35	24.5	M5	6.40
	35	22.5	104	30.5	43	30.5	M6	10.10
	43	28	120	34	52	34	M8	14.60
	63	40	208	64	80	64	M10	32.60

Tab. 17

Please note the technical information "Double-sided stroke" on page TR-42

> DSE

E version with extra stroke

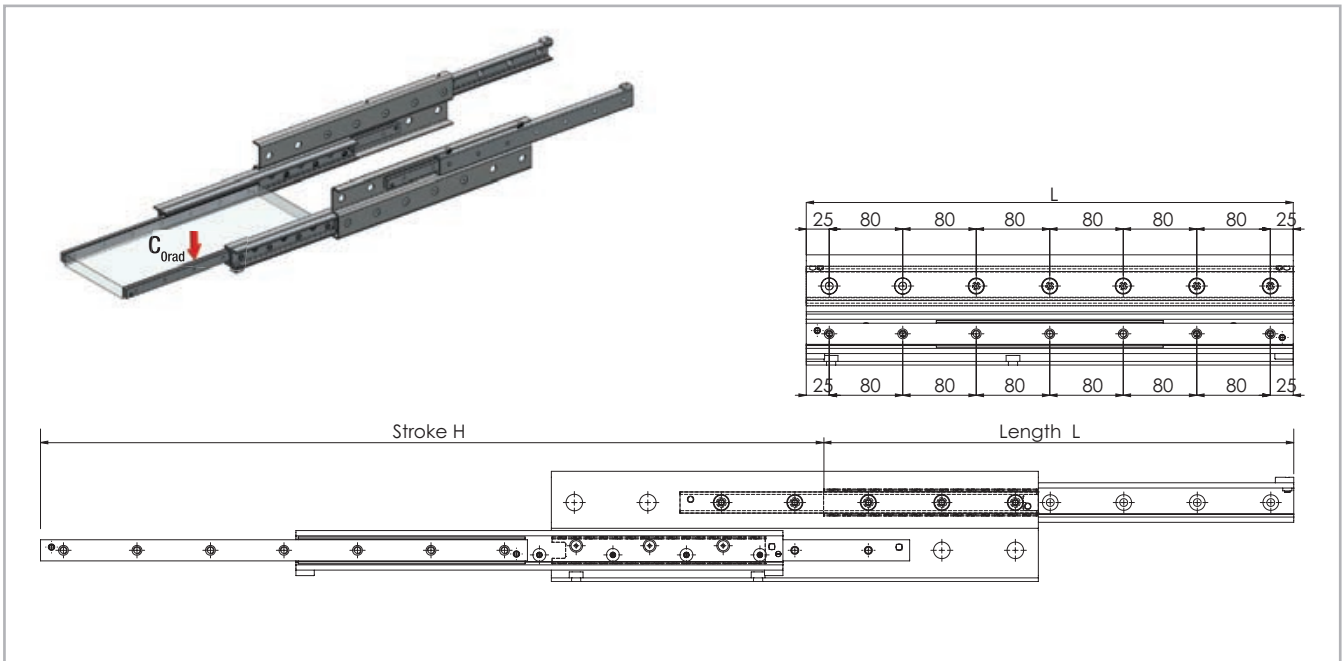

Fig. 44

Type	Size	Length L [mm]	Stroke H [mm]	Load capacity for a pair of rails C _{Orad} [N]	No. of holes fixed part	No. of holes mobile part
DSE	28	290	444	702	3 / 4	4
		370	570	952	4 / 5	5
		450	696	1200	4 / 6	6
		530	822	1450	6 / 7	7
		610	946	1702	6 / 8	8
		690	1072	1684	7 / 9	9
		770	1198	1506	7 / 10	10
		850	1297	1420	9 / 11	11
		930	1425	1292	9 / 12	12
		1010	1551	1184	10 / 13	13
		1090	1677	1094	10 / 14	14
		1170	1803	1016	12 / 15	15

Tab. 18

Type	Size	Length L [mm]	Stroke H [mm]	Load capacity for a pair of rails C _{Orad} [N]	No. of holes fixed part	No. of holes mobile part
DSE	35	450	741	1552	5 / 6	6
		530	837	2098	6 / 7	7
		610	969	2376	6 / 8	8
		690	1101	2652	7 / 9	9
		770	1197	3182	8 / 10	10
		850	1329	2850	9 / 11	11
		930	1461	2582	9 / 12	12
		1010	1557	2466	10 / 13	13
		1090	1689	2262	11 / 14	14
		1170	1821	2090	12 / 15	15
		1250	1917	2012	12 / 16	16
		1330	2049	1874	13 / 17	17
		1410	2181	1754	14 / 18	18
		1490	2277	1700	15 / 19	19

Tab. 19

Type	Size	Length L [mm]	Stroke H [mm]	Load capacity for a pair of rails C_{Orad} [N]	No. of holes fixed part	No. of holes mobile part
DSE	43	530	834	2582	6 / 7	7
		610	939	3264	6 / 8	8
		690	1089	3470	7 / 9	9
		770	1194	4154	7 / 10	10
		850	1299	4852	9 / 11	11
		930	1449	5012	9 / 12	12
		1010	1554	4728	10 / 13	13
		1090	1659	4476	11 / 14	14
		1170	1809	4044	12 / 15	15
		1250	1914	3856	12 / 16	16
		1330	2064	3532	13 / 17	17
		1410	2169	3388	13 / 18	18
		1490	2274	3256	15 / 19	19
		1570	2409	3078	15 / 20	20
		1650	2529	2916	16 / 21	21
		1730	2634	2818	16 / 22	22
		1810	2784	2640	18 / 23	23
1890	2889	2560	18 / 24	24		
1970	3039	2412	19 / 25	25		

Tab. 20

Type	Size	Length L [mm]	Stroke H [mm]	Load capacity for a pair of rails C_{Orad} [N]	No. of holes fixed part	No. of holes mobile part
DSE	63	610	999	4328	6 / 8	8
		690	1119	5260	8 / 9	9
		770	1239	6208	8 / 10	10
		850	1359	7164	9 / 11	11
		930	1479	8128	9 / 12	12
		1010	1599	9096	11 / 13	13
		1090	1719	10070	11 / 14	14
		1170	1839	11046	12 / 15	15
		1250	1959	11344	12 / 16	16
		1330	2079	10714	14 / 17	17
		1410	2199	10152	14 / 18	18
		1490	2319	9644	15 / 19	19
		1570	2439	9186	15 / 20	20
		1650	2559	8768	17 / 21	21
		1730	2679	8388	17 / 22	22
		1810	2799	8038	18 / 23	23
		1890	2919	7718	18 / 24	24
		1970	3039	7420	20 / 25	25

Tab. 21

> DSE

E version with extra stroke

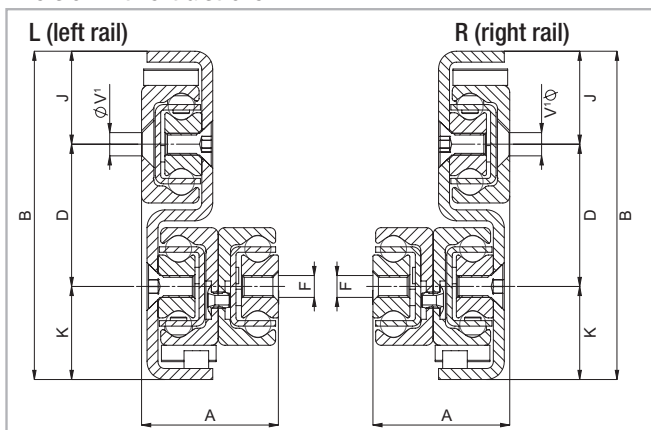

Fig. 45

¹ Fixing holes (V) for countersunk head screws according to DIN 7991
Please observe right or left installation for version DSE.

Type	Size	Cross-section							Weight per single guide [kg/m]
		A [mm]	B [mm]	K [mm]	D [mm]	J [mm]	F	V ¹	
DSE	28	30	84	24.5	35	24.5	M5	M5	8.4
	35	39.5	104	30.5	43	30.5	M6	M6	13.2
	43	50	120	34	52	34	M8	M8	19.9
	63	69	208	64	80	64	M8	M10	42.9

Tab. 22

> DSC

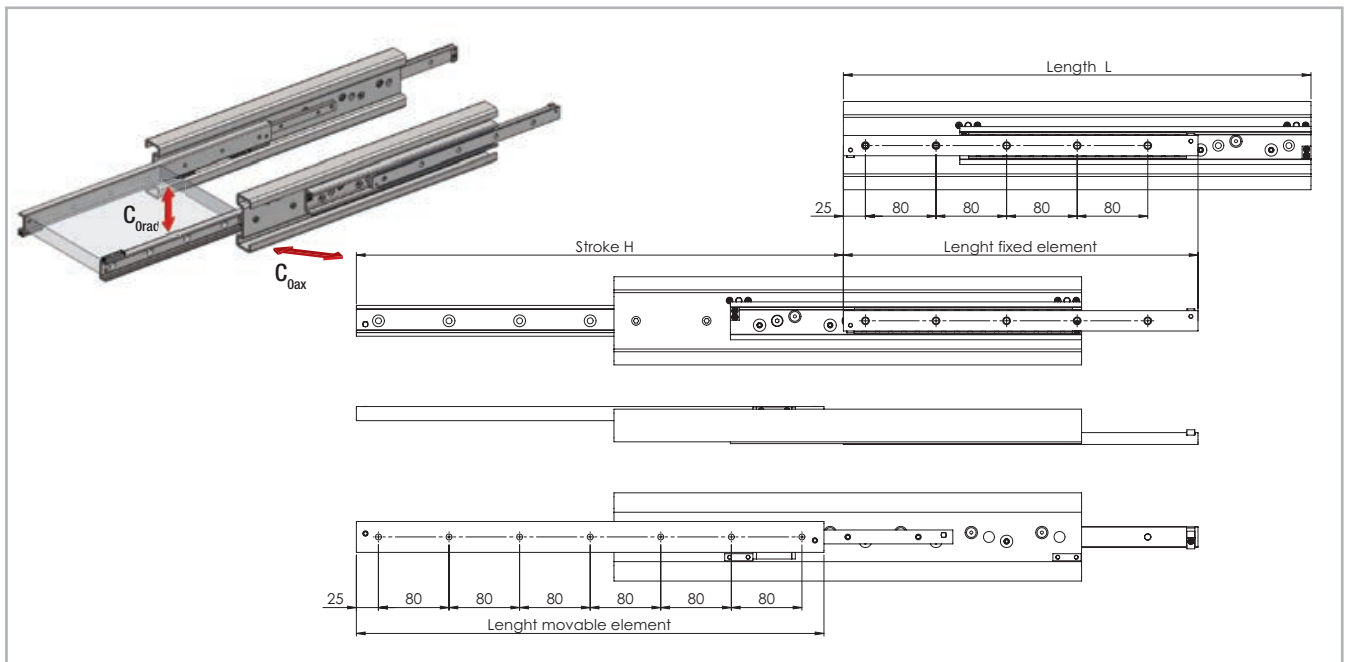
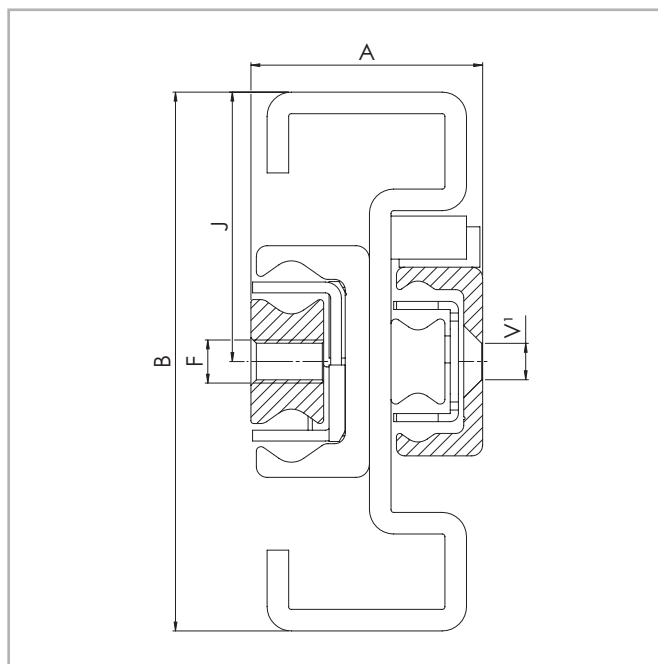

Fig. 46

Type	Size	Length L [mm]	Stroke H [mm]	Load capacity for a pair of rails		Fixed element		Movable element	
				C_{Orad} [N]	C_{Oax} [N]	Accessible holes / total	Length [mm]	Accessible holes / total	Length [mm]
DSC	43	530	552	4780	3346	5 / 5	402	6 / 7	530
		610	619	5928	4150	6 / 6	465	6 / 8	610
		690	725	6190	3840	6 / 6	520	8 / 9	690
		770	792	7332	3584	7 / 7	582	8 / 10	770
		850	859	8492	3362	8 / 8	644	9 / 11	850
		930	965	8738	2918	9 / 9	700	9 / 12	930
		1010	1029	10508	2784	10 / 10	770	11 / 13	1010
		1090	1099	11058	2634	10 / 10	825	11 / 14	1090
		1170	1202	10354	2364	11 / 11	887	12 / 15	1170
		1250	1272	9874	2254	12 / 12	942	12 / 16	1250
		1330	1375	8998	2054	13 / 13	1005	14 / 17	1330
		1410	1445	8634	1972	14 / 14	1060	14 / 18	1410
		1490	1509	8362	1910	14 / 14	1130	15 / 19	1490
		1570	1615	7698	1758	15 / 15	1185	16 / 20	1570
		1650	1685	7428	1696	15 / 15	1240	16 / 21	1650
		1730	1752	7202	1644	16 / 16	1302	17 / 22	1730
		1810	1843	6812	1556	17 / 17	1365	18 / 23	1810
1890	1922	6540	1494	18 / 18	1427	19 / 24	1890		
1970	2028	6126	1390	19 / 19	1482	20 / 25	1970		

Tab. 23

> DSC



¹ Fixing holes (V) for countersunk head screws according to DIN 7991

Fig. 47

Type	Size	Cross-section					Weight per single guide [kg/m]
		A [mm]	B [mm]	J [mm]	F [mm]	V' [mm]	
DSC	43	43	100	50	M8	M6	13.4

Tab. 24

> DE

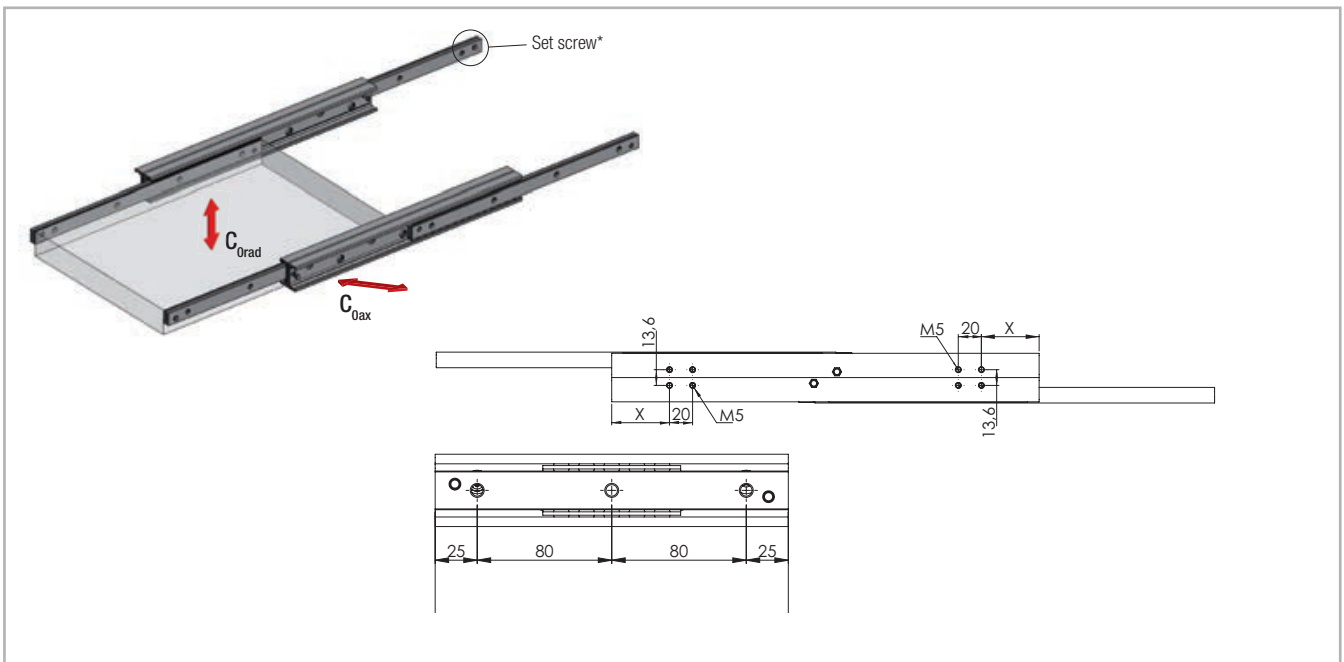

* Remove the set screw to reach all the fixing holes. See also assembly instructions on page TR-45f.

Fig. 48

Type	Size	Length L [mm]	Stroke H [mm]	Load capacity for a pair of rails		No. of holes
				C _{0rad} [N]	C _{0ax} [N]	
DEF DEV DEM	22	130	152	238	166	2
		210	222	562	392	3
		290	308	780	546	4
		370	392	1002	526	5
		450	462	1348	460	6
		530	548	1142	386	7
		610	632	988	334	8
		690	702	906	306	9
		770	788	802	270	10

Tab. 25

Type	Size	Length L [mm]	Stroke H [mm]	Load capacity for a pair of rails		No. of holes
				C _{0rad} [N]	C _{0ax} [N]	
DEF DEV DEM	28	130	148	470	328	2
		210	232	864	604	3
		290	296	1534	1074	4
		370	380	1936	942	5
		450	464	2338	770	6
		530	548	2214	650	7
		610	633	1910	560	8
		690	717	1684	494	9
		770	801	1506	442	10
		850	866	1420	416	11
		930	950	1292	378	12
		1010	1034	1184	348	13
		1090	1118	1094	320	14
		1170	1202	1016	298	15

Tab. 26

4 Dimensions and load capacity

Type	Size	Length L [mm]	Stroke H [mm]	Load capacity for a pair of rails		No. of holes
				C _{Orad} [N]	C _{Oax} [N]	
DEF DEV DEM	35	210	254	804	562	3
		290	318	1600	1120	4
		370	406	2050	1436	5
		450	494	2500	1586	6
		530	558	3370	1456	7
		610	646	3816	1252	8
		690	734	3378	1096	9
		770	798	3182	1032	10
		850	886	2850	926	11
		930	974	2582	838	12
		1010	1038	2466	800	13
		1090	1126	2262	734	14
		1170	1214	2090	678	15
		1250	1278	2012	654	16
		1330	1366	1874	608	17
		1410	1454	1754	570	18
		1490	1518	1700	552	19

Tab. 27

Type	Size	Length L [mm]	Stroke H [mm]	Load capacity for a pair of rails		No. of holes
				C _{Orad} [N]	C _{Oax} [N]	
DEF	63	610	666	8180	5726	8
		690	746	9718	6124	9
		770	826	11270	5568	10
		850	906	12830	5106	11
		930	986	14396	4714	12
		1010	1066	13770	4378	13
		1090	1146	12854	4086	14
		1170	1226	12052	3832	15
		1250	1306	11344	3606	16
		1330	1386	10714	3406	17
		1410	1466	10152	3228	18
		1490	1546	9644	3066	19
		1570	1626	9186	2920	20
		1650	1706	8768	2788	21
		1730	1786	8388	2666	22
		1810	1866	8038	2556	23
		1890	1946	7718	2454	24
		1970	2026	7420	2360	25

Tab. 29

Type	Size	Length L [mm]	Stroke H [mm]	Load capacity for a pair of rails		No. of holes
				C _{Orad} [N]	C _{Oax} [N]	
DEF DEV DEM	43	210	246	1210	848	3
		290	316	2228	1560	4
		370	416	2600	1820	5
		450	486	3656	2558	6
		530	556	4750	2868	7
		610	626	5868	2600	8
		690	726	6182	2192	9
		770	796	6110	2032	10
		850	866	5694	1892	11
		930	966	5012	1666	12
		1010	1036	4728	1572	13
		1090	1106	4476	1488	14
		1170	1206	4044	1344	15
		1250	1276	3856	1282	16
		1330	1376	3532	1174	17
		1410	1446	3388	1126	18
		1490	1516	3256	1082	19
		1570	1586	3134	1042	20
		1650	1686	2916	970	21
		1730	1756	2818	936	22
		1810	1856	2640	878	23
		1890	1926	2560	850	24
		1970	2026	2412	802	25

Tab. 28

> DE

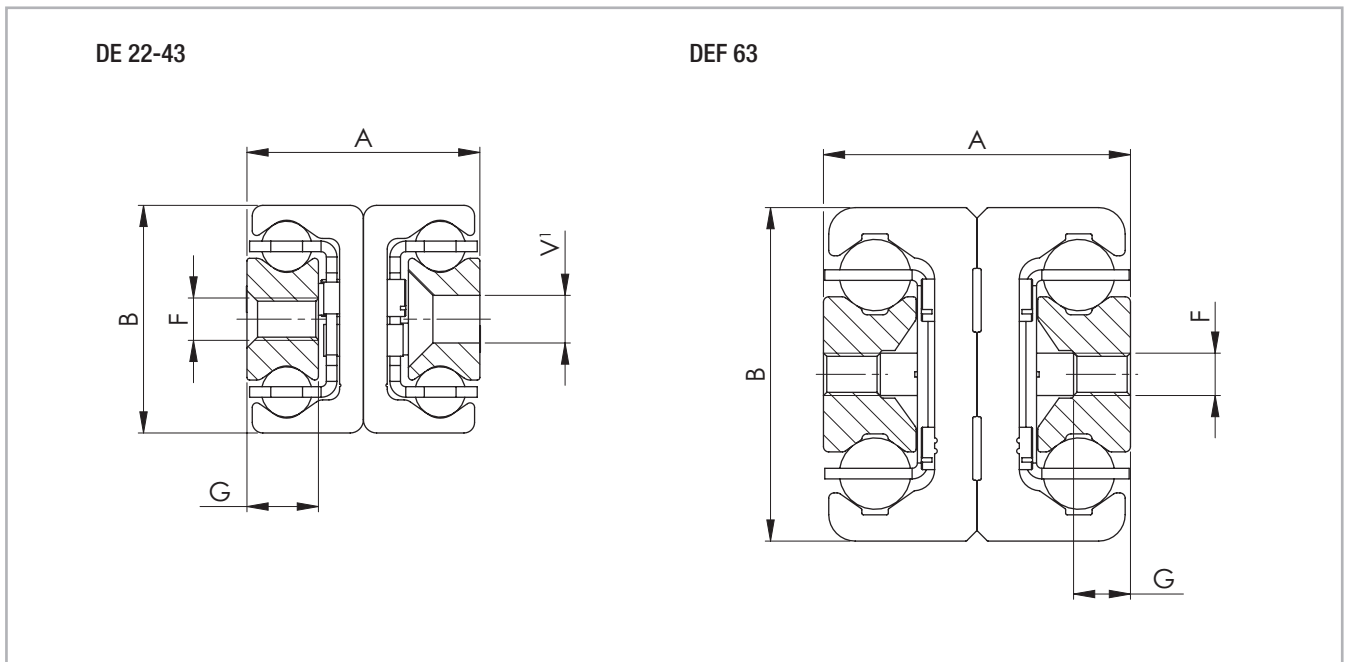

¹ Fixing holes (V) for countersunk head screws according to DIN 7991

Fig. 49

Type	Size	Cross-section					Weight per single guide [kg/m]
		A [mm]	B [mm]	G [mm]	F	V	
DEF DEV DEM	22	22	22	6.5	M4	M4	2.64
	28	26	28	7.5	M5	M5	4.04
	35	34	35	10	M6	M6	6.10
	43	44	43	13.5	M8	M8	10.50
	63	58	63	10.5	M8	-	20.60

Tab. 30

Please note the technical information "Double-sided stroke" on page TR-42

There are three options for mounting holes available for the DE series in sizes 22 to 43:

Version DEF with threaded holes,

Version DEV with counter-sunk holes,

Version DEM, both variants (mixed) (see fig. 52).

Size 63 is only available with threaded holes.

> DE...S

...S version with reinforced and damped stainless steel end stops

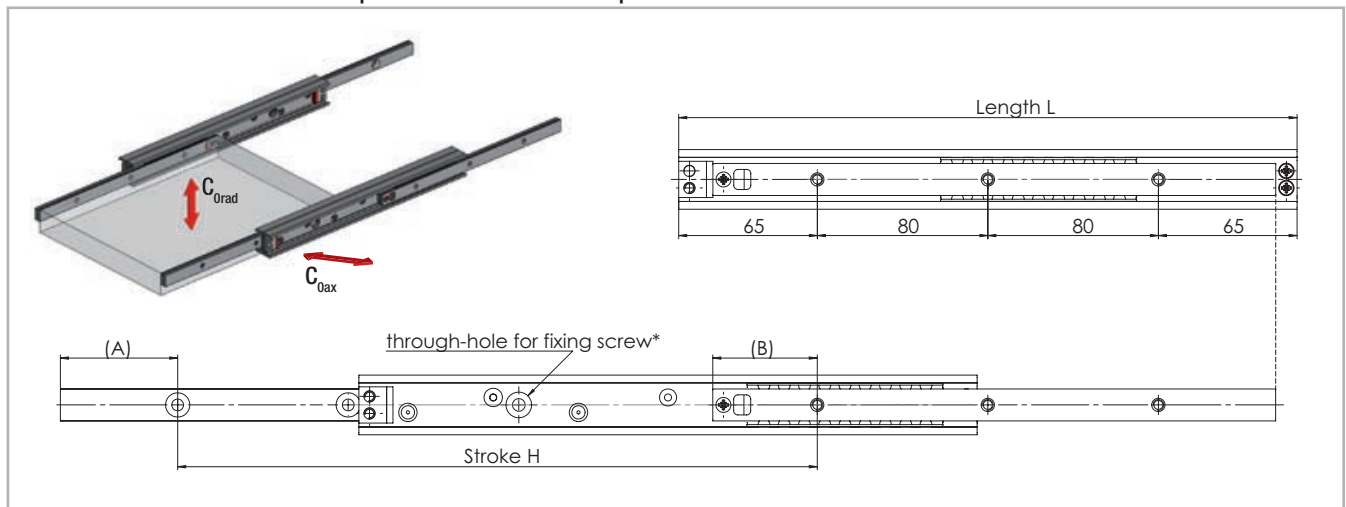

Fig. 50

Type	Size	Length L [mm]	Stroke H [mm]	Load capacity for a pair of rails		Slider [mm]	A [mm]	B [mm]	No of holes
				C _{Orad} [N]	C _{Oax} [N]				
DE...S	28	290	300	704	494	264	55	49	3
		370	384	1084	758	344			4
		450	468	1470	756	424			5
		530	533	2100	686	504			6
		610	636	1892	556	584			7
		690	701	1760	516	664			8
		770	804	1494	438	744			9
		850	850	1474	432	824			10
		930	953	1284	376	904			11
		1010	1018	1222	358	984			12
		1090	1102	1124	330	1064			13
		1170	1186	1042	306	1144			14

Tab. 31

Type	Size	Length L [mm]	Stroke H [mm]	Load capacity for a pair of rails		Slider [mm]	A [mm]	B [mm]	No of holes
				C _{Orad} [N]	C _{Oax} [N]				
DE...S	35	370	370	1430	1000	338	53	45	4
		450	464	1788	1252	418			5
		530	536	2476	1574	498			6
		610	630	2832	1312	578			7
		690	702	3540	1194	658			8
		770	796	3198	1038	738			9
		850	868	2966	962	818			10
		930	962	2644	858	898			11
		1010	1012	2592	842	978			12
		1090	1128	2254	732	1058			13
		1170	1178	2216	720	1138			14
		1250	1272	2030	660	1218			15
		1330	1344	1936	628	1298			16
		1410	1438	1792	582	1378			17
		1490	1510	1718	558	1458			18

Tab. 32

Type	Size	Length L [mm]	Stroke H [mm]	Load capacity for a pair of rails		Slider [mm]	A [mm]	B [mm]	No of holes
				C_{0rad} [N]	C_{0ax} [N]				
DE...S	43	370	366	2014	1410	338	53	45	4
		450	496	1864	1306	418			5
		530	536	3418	2394	498			6
		610	636	3796	2522	578			7
		690	706	4838	2312	658			8
		770	806	5206	1982	738			9
		850	846	5964	1982	818			10
		930	976	4914	1634	898			11
		1010	1016	4914	1634	978			12
		1090	1116	4398	1462	1058			13
		1170	1186	4178	1390	1138			14
		1250	1286	3798	1262	1218			15
		1330	1326	3798	1262	1298			16
		1410	1456	3344	1112	1378			17
		1490	1496	3344	1112	1458			18
		1570	1596	3096	1030	1538			19
		1650	1666	2986	992	1618			20
		1730	1766	2786	926	1698			21
		1810	1806	2786	926	1778			22
		1890	1936	2534	842	1858			23
		1970	2066	2322	772	1938			24

Tab. 33

> DE...S

...S version with reinforced and damped stainless steel end stops

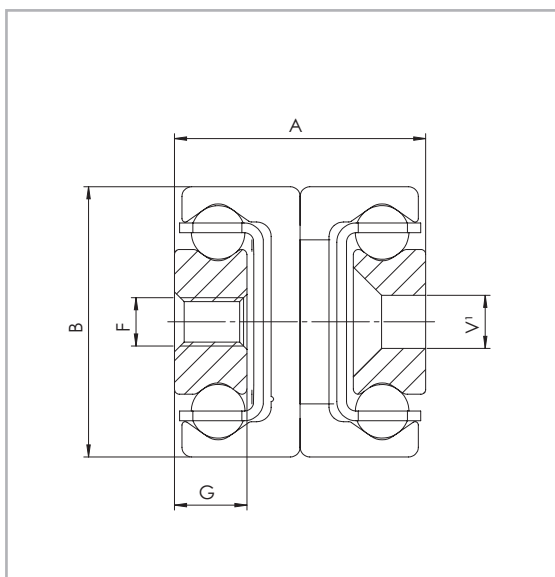

¹ Fixing holes (V) for countersunk head screws according to DIN 7991 Fig. 51

Type	Size	Cross-section					Weight per single guide [kg/m]
		A [mm]	B [mm]	G [mm]	F	V	
DE...S	28	26	28	7.5	M5	M5	4.04
	35	34	35	10	M6	M6	6.10
	43	44	43	13.5	M8	M8	10.50

Tab. 34

> DE...D

DED with double direction stroke (double stroke)

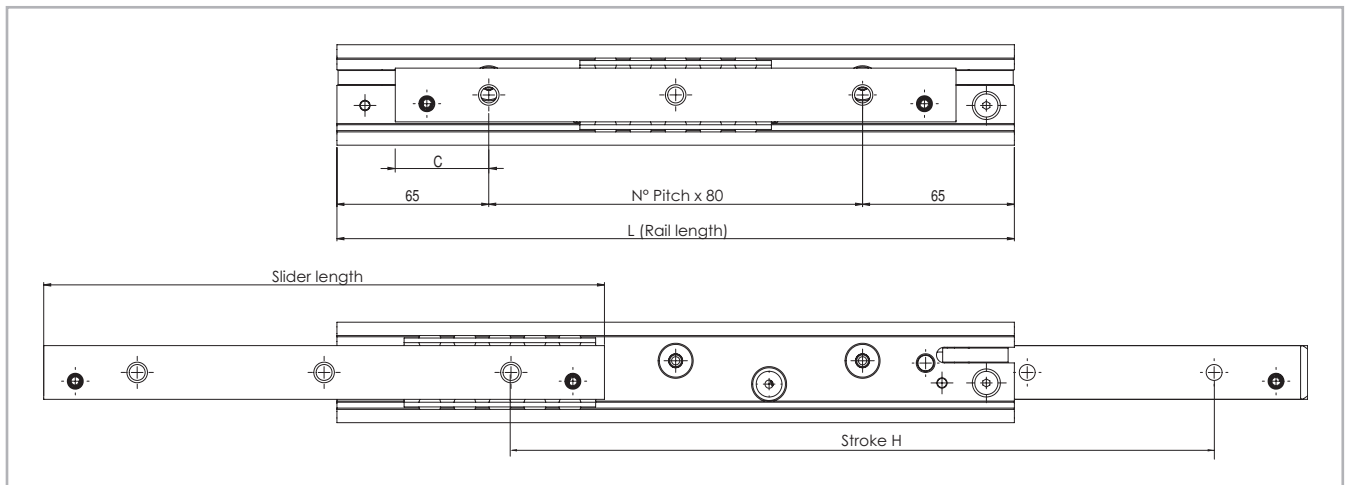

Fig. 52

D version (with a driving disc)

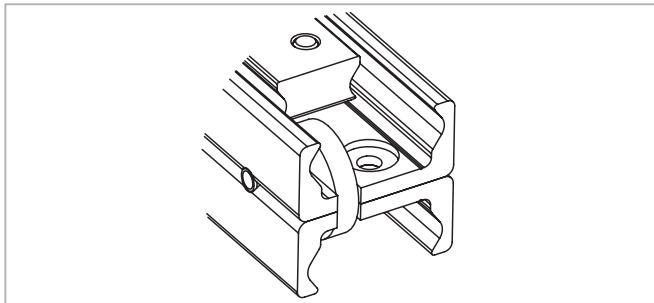

Fig. 53

The driving disc in the intermediate element in the DE...D versions acts to make sure that in bilateral strokes (double strokes) the intermediate element always returns to the correct position and does not remain in an undefined position. This design is available in sizes 28, 35, 43 and 63 with all three versions of the fixing holes. This version is based on the standard DE series version, but differs in the technical characteristics for the construction methods. Please contact our technical service department for more information.

Type	Size	Length L [mm]	Stroke H [mm]	Load capacity for a pair of rails		Slider [mm]	C [mm]	No. of holes
				C _{0rad} [N]	C _{0ax} [N]			
DEF...D DEV...D DEM...D	28	290	292	836	586	250	45	3
		370	376	1224	856	330	45	4
		450	460	1618	782	410	45	5
		530	544	2014	658	490	45	6
		610	628	1940	570	570	45	7
		690	712	1706	500	650	45	8
		770	796	1524	448	730	45	9
		850	880	1376	404	810	45	10
		930	964	1256	368	890	45	11
		1010	1048	1154	338	970	45	12
		1090	1132	1068	314	1050	45	13
		1170	1216	992	292	1130	45	14

Tab. 35

Type	Size	Length L [mm]	Stroke H [mm]	Load capacity for a pair of rails		Slider [mm]	C [mm]	No. of holes
				C _{0rad} [N]	C _{0ax} [N]			
DEF...D DEV...D DEM...D	35	290	303	890	624	250	45	3
		370	391	1322	926	330	45	4
		450	479	1760	1232	410	45	5
		530	543	2562	1534	490	45	6
		610	631	3012	1308	570	45	7
		690	719	3460	1140	650	45	8
		770	783	3302	1072	730	45	9
		850	871	2946	956	810	45	10
		930	959	2660	864	890	45	11
		1010	1023	2536	824	970	45	12
		1090	1111	2322	754	1050	45	13
		1170	1199	2140	694	1130	45	14
		1250	1263	2060	668	1210	45	15
		1330	1351	1916	622	1290	45	16
		1410	1439	1790	582	1370	45	17
		1490	1503	1734	562	1450	45	18

Tab. 36

Type	Size	Length L [mm]	Stroke H [mm]	Load capacity for a pair of rails		Slider [mm]	C [mm]	No. of holes
				C _{0rad} [N]	C _{0ax} [N]			
DED...D DEV...D DEN...D	43	290	301	1002	702	240	40	3
		370	401	1400	980	320	40	4
		450	471	2318	1622	400	40	5
		530	541	3312	2318	480	40	6
		610	641	3696	2484	560	40	7
		690	711	4724	2280	640	40	8
		770	781	5784	2108	720	40	9
		850	881	5506	1830	800	40	10
		930	951	5166	1718	880	40	11
		1010	1021	4866	1618	960	40	12
		1090	1121	4360	1450	1040	40	13
		1170	1191	4144	1378	1120	40	14
		1250	1261	3948	1312	1200	40	15
		1330	1361	3608	1200	1280	40	16
		1410	1431	3458	1150	1360	40	17
		1490	1501	3322	1104	1440	40	18
		1570	1601	3076	1024	1520	40	19
		1650	1671	2968	986	1600	40	20
		1730	1741	2866	952	1680	40	21
		1810	1841	2682	892	1760	40	22
		1890	1911	2600	864	1840	40	23
		1970	2011	2448	814	1920	40	24

Tab. 37

Type	Size	Length L [mm]	Stroke H [mm]	Load capacity for a pair of rails		Slider [mm]	C [mm]	No. of holes
				C _{0rad} [N]	C _{0ax} [N]			
DEF...D	63	610	602	7688	5382	558	39	7
		690	682	9236	6466	638	39	8
		770	762	10796	6514	718	39	9
		850	842	12362	5890	798	39	10
		930	922	13934	5374	878	39	11
		1010	1002	15512	4942	958	39	12
		1090	1082	14386	4574	1038	39	13
		1170	1162	13388	4256	1118	39	14
		1250	1242	12520	3980	1198	39	15
		1330	1322	11758	3738	1278	39	16
		1410	1402	11084	3524	1358	39	17
		1490	1482	10482	3332	1438	39	18
		1570	1562	9942	3160	1518	39	19
		1650	1642	9456	3006	1598	39	20
		1730	1722	9014	2866	1678	39	21
		1810	1802	8612	2738	1758	39	22
		1890	1882	8244	2620	1838	39	23
		1970	1962	7906	2514	1918	39	24

Tab. 38

> DED version D

DED with double direction stroke (double stroke)

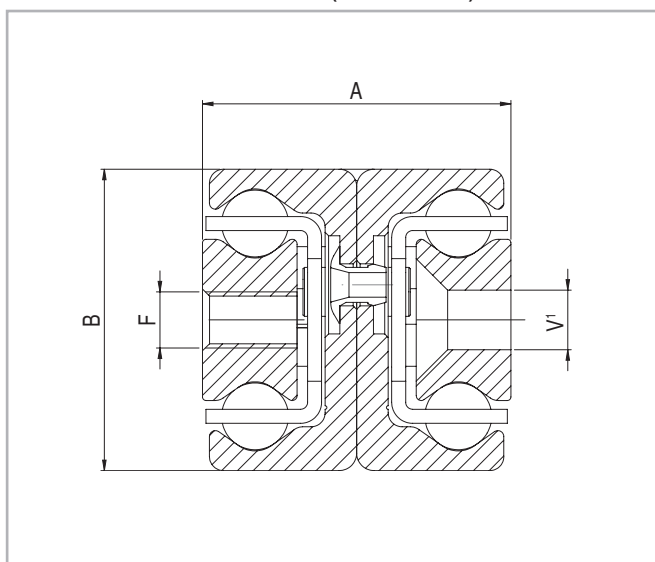

¹ Fixing holes (V) for countersunk head screws according to DIN 7991

Fig. 54

Type	Size	Cross-section				Weight per single guide [kg/m]
		A [mm]	B [mm]	F	V ¹	
DE...D	28	26	28	M5	M5	4.04
	35	34	35	M6	M6	6.10
	43	44	43	M8	M8	10.50
	63	58	63	M8	-	20.60

Tab. 39

There are three options for mounting holes available for the DE...D series in sizes 28 to 43:

Version DEF with threaded holes,

Version DEV with counter-sunk holes,

Version DEM, both variants (mixed).

Size 63 is only available with threaded holes.

> DE...Z

Version Z with synchronized full extension

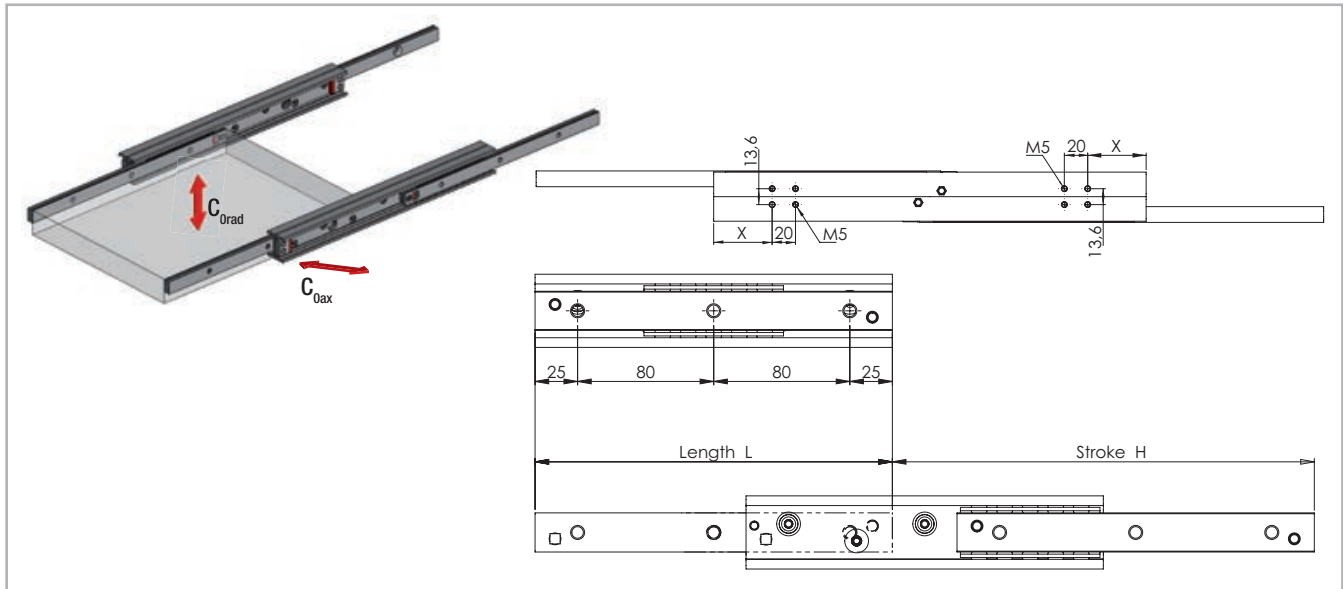

Fig. 55

Type ¹	Size	Length L [mm]	Stroke H [mm]	X	Load capacity for a pair of rails		No. of holes
					C _{Orad} [N]	C _{Oax} [N]	
DEF...Z	43	290	243	30	1746	1222	4
		370	323	50	1947	1363	5
		450	403	70	2481	1737	6
		530	483	90	3016	1915	7
		610	563	110	3229	1618	8
		690	643	130	3762	1401	9
		770	723	150	3714	1235	10
		850	803	170	3321	1104	11
		930	883	190	3004	999	12
		1010	963	210	2741	911	13
		1090	1043	230	2521	838	14
		1170	1123	250	2334	776	15
		1250	1203	270	2172	722	16
		1330	1283	290	2032	675	17
		1410	1363	310	1908	634	18
		1490	1443	330	1799	598	19
		1570	1523	350	1701	566	20
		1650	1603	370	1614	537	21
		1730	1683	390	1535	510	22
		1810	1763	410	1463	486	23
1890	1843	430	1398	465	24		
1970	1923	450	1338	445	25		

Z version (with rack and pinion)

The rack and pinion system allows the rail to open starting from the intermediate element, thus permitting a synchronized full extension and guaranteeing a multiplication of the drive (for equal lengths in rail stroke, the drive stroke is cut in half). This version is based on the standard DE series version, but differs in the technical characteristics for the construction methods. Please contact our technical service department for more information.

¹ The synchronized full extension is only available in version F with threaded mounting holes

Tab. 40

> DE...Z

DE...Z with double direction stroke (double stroke)

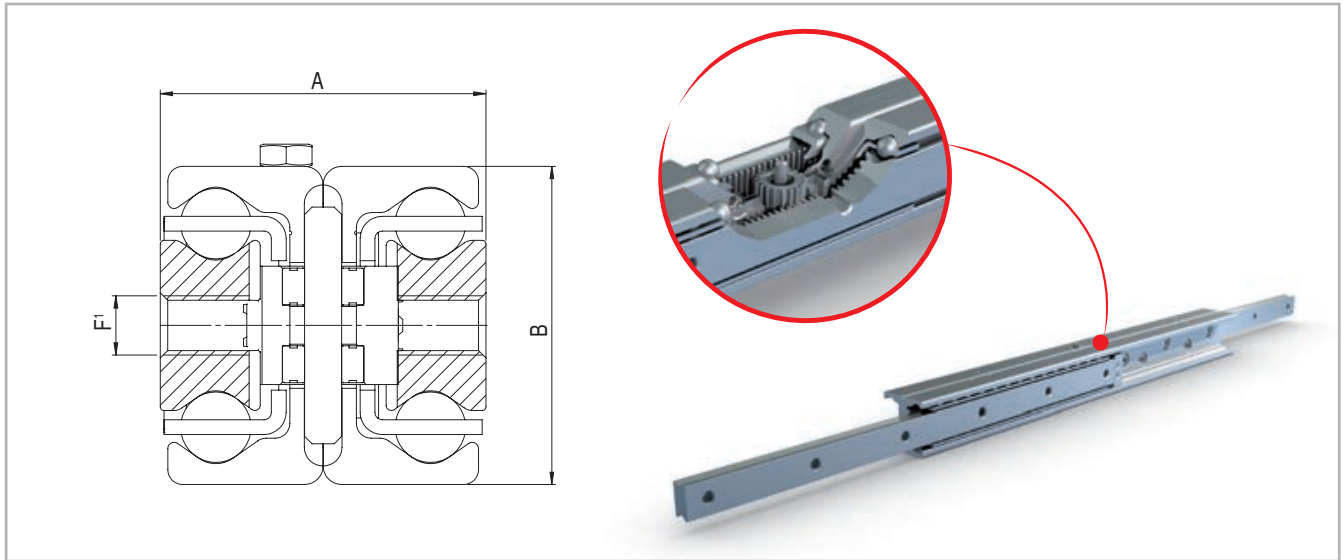

¹ Fixing holes (V) for countersunk head screws according to DIN 7991
 * Max shaft length 10mm

Fig. 56

Type	Size	Cross-section			Weight per single guide [kg/m]
		A [mm]	B [mm]	F	
DEF...Z	43	44	43	M8	10.50

Tab. 41

DEF43Z with threaded holes is available in left and right version:

DEF43Z...L

DEF43Z...R

> **DBN**

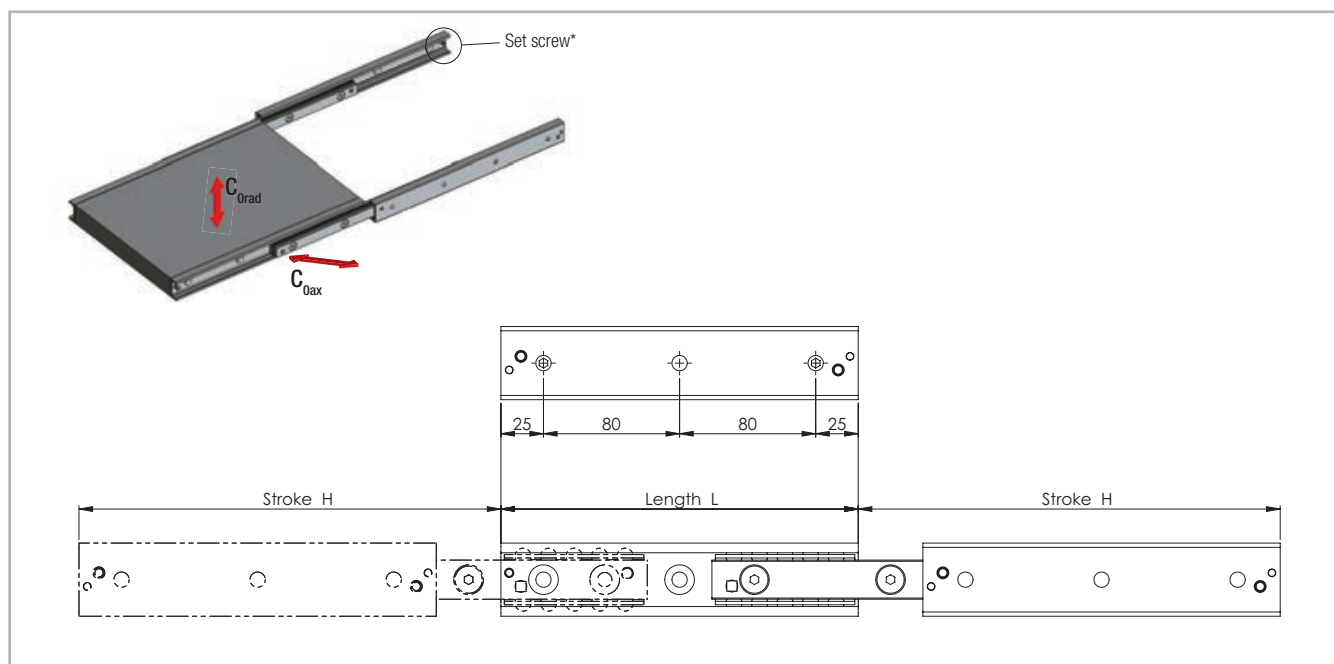

* Remove the set screw to reach all the fixing holes. See also assembly instructions on page TR-45f.

Fig. 57

Type	Size	Length L [mm]	Stroke H [mm]	Load capacity for a pair of rails		No. of holes
				C _{Orad} [N]	C _{Oax} [N]	
DBN	22	130	152	238	166	2
		210	222	562	392	3
		290	308	472	472	4
		370	392	372	372	5
		450	462	324	324	6
		530	548	272	272	7
		610	632	234	234	8
		690	702	216	216	9
		770	788	190	190	10

Tab. 42

Type	Size	Length L [mm]	Stroke H [mm]	Load capacity for a pair of rails		No. of holes
				C _{Orad} [N]	C _{Oax} [N]	
DBN	28	130	148	470	328	2
		210	232	864	604	3
		290	296	1244	1074	4
		370	380	964	964	5
		450	464	786	786	6
		530	548	664	664	7
		610	633	572	572	8
		690	717	504	504	9
		770	801	452	452	10
		850	866	426	426	11
		930	950	388	388	12
		1010	1034	356	356	13
		1090	1118	328	328	14
		1170	1202	304	304	15

Tab. 43

Type	Size	Length L [mm]	Stroke H [mm]	Load capacity for a pair of rails		No. of holes
				C _{Orad} [N]	C _{Oax} [N]	
DBN	35	210	254	804	562	3
		290	318	1334	1120	4
		370	406	1044	1044	5
		450	494	858	858	6
		530	558	788	788	7
		610	646	676	676	8
		690	734	594	594	9
		770	798	558	558	10
		850	886	500	500	11
		930	974	454	454	12
		1010	1038	434	434	13
		1090	1126	398	398	14
		1170	1214	366	366	15
		1250	1278	354	354	16
		1330	1366	330	330	17
		1410	1454	308	308	18
		1490	1518	298	298	19

Tab. 44

Type	Size	Length L [mm]	Stroke H [mm]	Load capacity for a pair of rails		No. of holes
				C _{Orad} [N]	C _{Oax} [N]	
DBN	43	210	246	1210	848	3
		290	316	2228	1560	4
		370	416	2600	1820	5
		450	486	2662	2558	6
		530	556	2386	2386	7
		610	626	2164	2164	8
		690	726	1824	1824	9
		770	796	1690	1690	10
		850	866	1576	1576	11
		930	966	1386	1386	12
		1010	1036	1308	1308	13
		1090	1106	1238	1238	14
		1170	1206	1118	1118	15
		1250	1276	1066	1066	16
		1330	1376	976	976	17
		1410	1446	938	938	18
		1490	1516	900	900	19
		1570	1586	868	868	20
		1650	1686	806	806	21
		1730	1756	780	780	22
		1810	1856	730	730	23
		1890	1926	708	708	24
		1970	2026	668	668	25

Tab. 45

> DBN

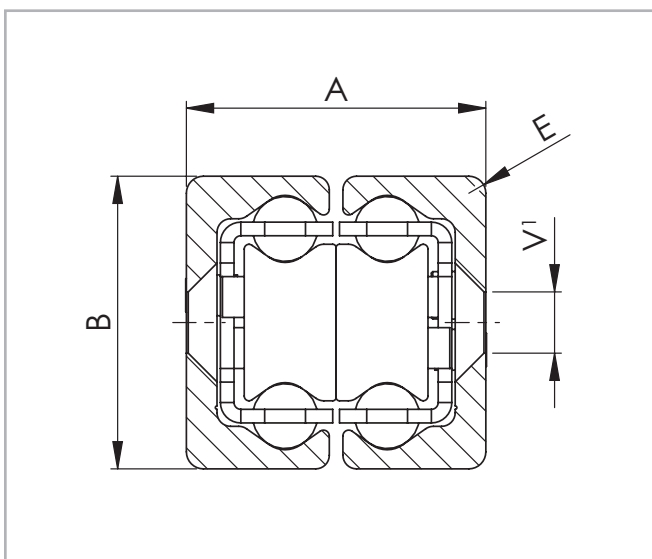

¹ Fixing holes (V) for countersunk head screws according to DIN 7991

Fig. 58

Type	Size	Cross-section				Weight per single guide [kg/m]
		A [mm]	B [mm]	E [mm]	V	
DBN	22	22	22	3	M4	2.64
	28	26	28	1	M5	4.04
	35	34	35	2	M6	6.10
	43	44	43	2.5	M8	10.50

Tab. 46

Please note the technical information "Double-sided stroke" on page TR-42

> DMS

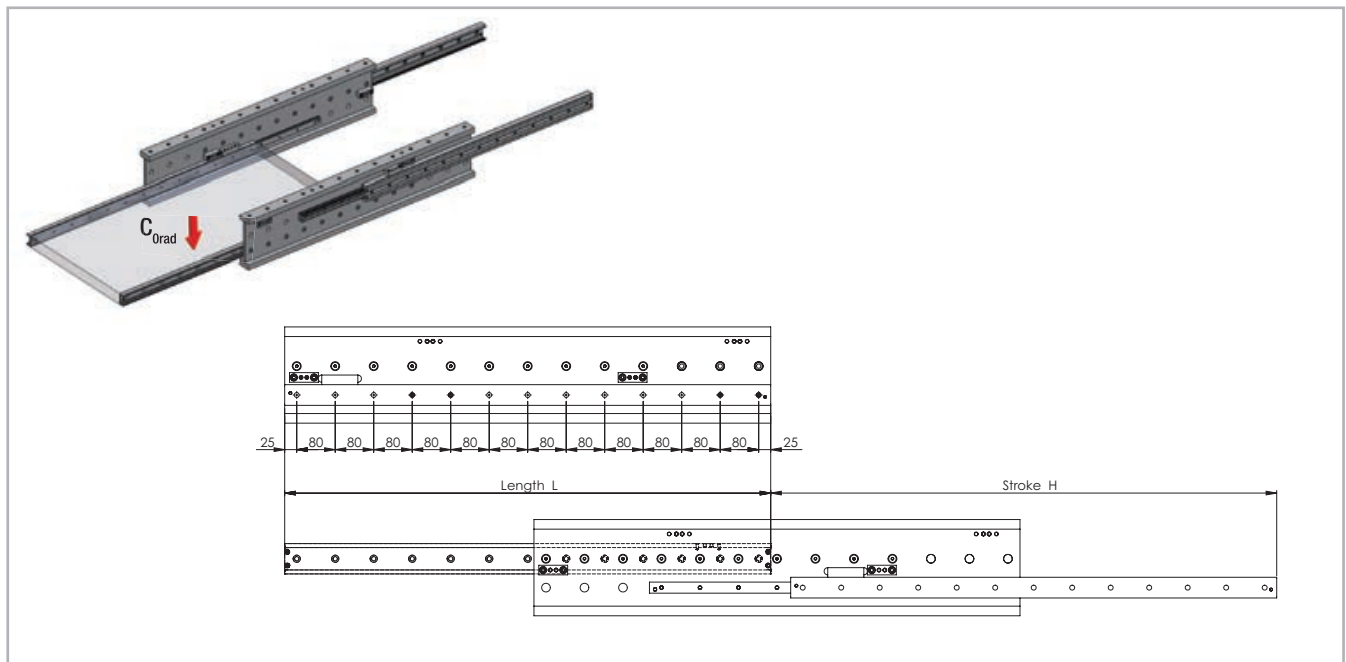

Fig. 59

Type	Size	Length L [mm]	Stroke H [mm]	Load capacity for a pair of rails C_{Orad} [N]	Fixed element Accessible holes / total	Movable element Accessible holes / total
DMS	63	1010	1051	16104	10 / 13	10 / 13
		1090	1141	17496	10 / 14	11 / 14
		1170	1216	19168	11 / 15	11 / 15
		1250	1291	20848	12 / 16	13 / 16
		1330	1381	22238	13 / 17	13 / 17
		1410	1456	23920	13 / 18	14 / 18
		1490	1531	25608	14 / 19	14 / 19
		1570	1621	26996	14 / 20	15 / 20
		1650	1696	28686	16 / 21	16 / 21
		1730	1771	30380	16 / 22	17 / 22
		1810	1861	31766	17 / 23	17 / 23
		1890	1936	33460	18 / 24	19 / 24
		1970	2026	34846	19 / 25	19 / 25
		2050	2101	36542	19 / 26	20 / 26
		2130	2176	38240	20 / 27	20 / 27
2210	2266	39624	21 / 28	22 / 28		

Tab. 47

> DMS

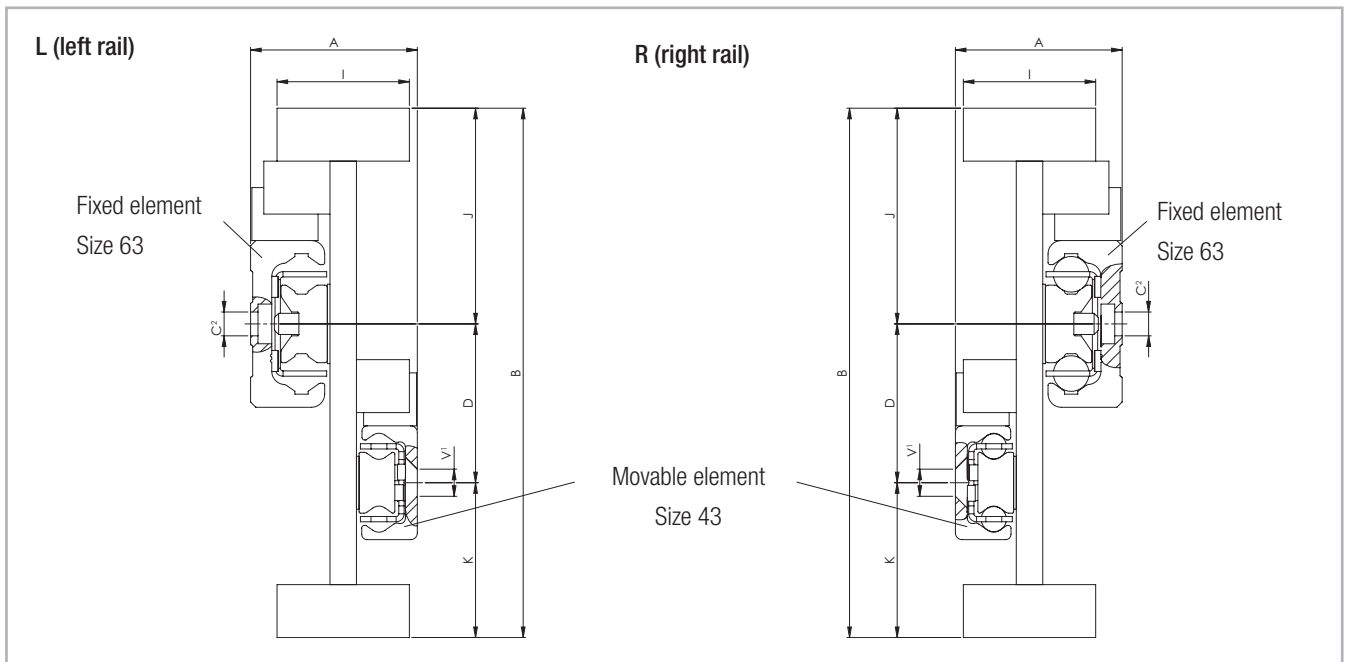

Fig. 60

¹ Fixing holes (V) for countersunk head screws according to DIN 7991

² Fixing holes (C) for socket cap screws according to DIN 7984. Alternative fixing with Torx® screws in special design with low head (on request)
Please observe right or left installation for version DMS.

Type	Size	Cross-section								Weight per single guide [kg/m]
		A [mm]	B [mm]	I [mm]	K [mm]	D [mm]	J [mm]	C	V	
DMS	63	63	200	50	58.5	60	81.5	M8	M8	43

Tab. 48

Technical instructions



> Telescopic rail selection

Selecting the suitable telescopic rail should be done based on the load and the maximum permissible deflection in the extended state. The load capacity of a telescopic rail depends on two factors: the loading capacity of the ballage and the rigidity of the intermediate element. For mainly short strokes the load capacity is determined by the load-bearing capacity of the ballage; for average and long strokes it is determined by the rigidity of the intermediate element. Therefore series, which otherwise contain comparable components, are also suited for differing load capacities.

> Static load check

The values in the load capacity tables of the corresponding series (see Sect. 4, Product Dimensions, pg. TR-8ff) give the maximum permissible loading of a pair of rails in the middle of the two rails and in the center line of the moving element with the rails in the completely extended state.

Using a pair of rails, the loading acts in the centre on both rails (see fig. 62, P₁).

The load capacity of a rail pair is:

$$P_1 = C_{Orad}$$

Fig. 61

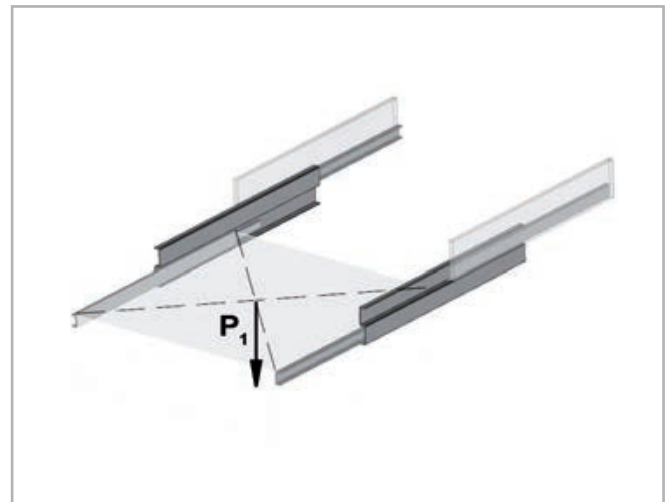

Fig. 62

> Deflection

If the load P acts vertically on the pair of rails (see fig. 63), the expected elastic deflection in the extended state can be determined as follows:

$$f = \frac{q}{t} \cdot P \quad (\text{mm})$$

Fig. 63

Whereby:

f is the expected elastic deflection in mm

q is a stroke coefficient (see fig. 66)

t is a factor depending on the model of the telescopic rail (see fig. 64)

P is the actual load acting on the centre of a pair of rails, in N

Also refer to page TR-38 for checking the static load

DS28	t = 360	DBN22	t = 6
DS35	t = 940	DBN28	t = 16
DS43	t = 1600	DBN35	t = 26
DS63	t = 8000	DBN43	t = 112
DE22	t = 16	DMS63	t = 7000
DE28	t = 34	DSC43	t = 1600
DE35	t = 108		
DE43	t = 240		
DE63	t = 1080		

Fig. 64

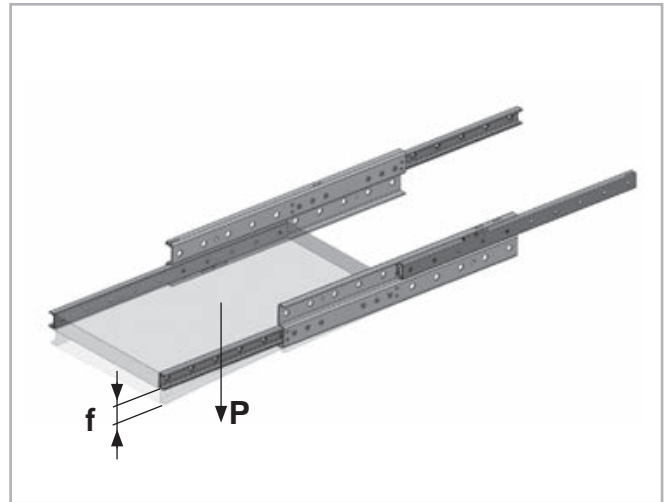

Fig. 65

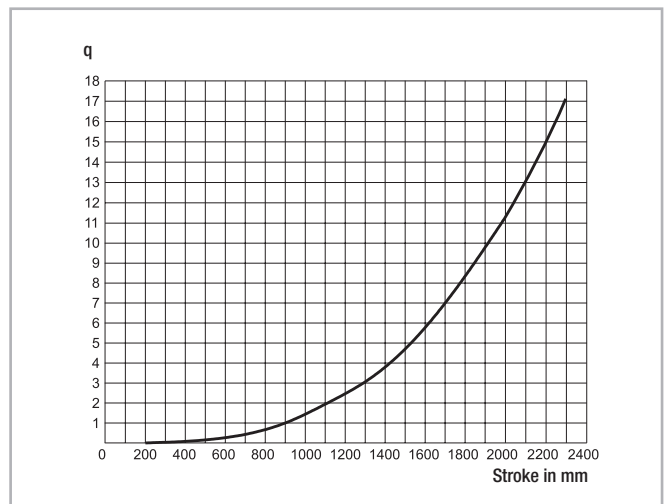

Fig. 66

This estimated value assumes an absolutely rigid adjacent construction. If this rigidity is not present, the actual deflection will deviate from the calculation.

Important:

With the partial extensions of the ASN series, the deflection is almost completely determined by the rigidity, i.e. by the moment of inertia of the adjacent construction.

For guides Series DSE please contact Rollon technical support.

> Static load

The telescopic extension of the various series allow different forces and moments (see Sect. 4, Product dimensions, pg. TR-8ff).

During the static tests the radial load capacity, C_{Orad} , the axial load capacity, C_{Oax} , and moments M_x , M_y and M_z indicate the maximum permissible values of the loads; higher loads negatively effect the running properties

and the mechanical strength. A safety factor, S_0 , is used to check the static load, which takes into account the basic parameters of the application and is defined in more detail in the following table:

Safety factor S_0

Neither shocks nor vibrations, smooth and low-frequency reverse, high assembly accuracy, no elastic deformations	1.5
Normal installation conditions	1.5 - 2
Shocks and vibrations, high-frequency reverse, significant elastic deformation	2 - 3.5

Tab. 49

The ratio of the actual load to maximum permissible load may be as large as the reciprocal of the accepted safety factor, S_0 , at the most.

$\frac{P_{Orad}}{C_{Orad}} \leq \frac{1}{S_0}$	$\frac{P_{Oax}}{C_{Oax}} \leq \frac{1}{S_0}$	$\frac{M_1}{M_x} \leq \frac{1}{S_0}$	$\frac{M_2}{M_y} \leq \frac{1}{S_0}$	$\frac{M_3}{M_z} \leq \frac{1}{S_0}$
--	--	--------------------------------------	--------------------------------------	--------------------------------------

Fig. 67

The above formulas are valid for a single load case. If two or more of the described forces act simultaneously, the following check must be made:

$\frac{P_{Orad}}{C_{Orad}} + \frac{P_{Oax}}{C_{Oax}} + \frac{M_1}{M_x} + \frac{M_2}{M_y} + \frac{M_3}{M_z} \leq \frac{1}{S_0}$	<p>P_{Orad} = effective radial load C_{Orad} = permissible radial load P_{Oax} = effective axial load C_{Oax} = permissible axial load M_1 = effective moment in the x-direction M_x = permissible moment in the x-direction M_2 = effective moment in the y-direction M_y = permissible moment in the y-direction M_3 = effective moment in the z-direction M_z = permissible moment in the z-direction</p>
--	---

Fig. 68

> Service life

The service life is defined as the time span between commissioning and the first sign of fatigue or wear indications on the raceways. The service life of a telescopic rail is dependent on several factors, such as the effective load, the installation precision, occurring shocks and vibrations, the operating temperature, the ambient conditions and the lubrication. Calculation of the service life is based exclusively on the loaded rows of balls.

In practice, the decommissioning of the bearing, due to its destruction or extreme wear of a component, represents the end of service life. This is taken into account by an application coefficient (f_i in the formula below), so the service life consists of:

$$L_{km} = 100 \cdot \left(\frac{\delta}{W} \cdot \frac{1}{f_i} \right)^3$$

L_{km} = calculated service life in km
 δ = load capacity factor in N
 W = equivalent load in N for a pair of rails
 f_i = application coefficient

Fig. 69

Application coefficient f_i

	ASN, DS, DE, DBN, DSC
Neither shocks nor vibrations, smooth and low-frequency direction change, clean environment	1.3 - 1.8
Light vibrations and average direction change	1.8 - 2.3
Shocks and vibrations, high-frequency direction change, very dirty environment	2.3 - 3.5

Tab. 50

If the external load, P , is the same as the dynamic load capacity, C_{0rad} , (which of course must never be exceeded), the service life at ideal operating conditions ($f_i = 1$) amounts to 100 km.

Naturally, for a single load P , the following applies: $W = P$. If several external loads occur simultaneously, the equivalent load is calculated as follows:

$$W = P_{rad} + \left(\frac{P_{ax}}{C_{0ax}} + \frac{M_1}{M_x} + \frac{M_2}{M_y} + \frac{M_3}{M_z} \right) \cdot C_{0rad}$$

Fig. 70

Load capacity factor δ

Length [mm]	ASN				
	22	28	35	43	63
	δ [N]				
130	830	1744			
210	1864	3154	3066	4576	
290	2590	5384	5812	8110	
370	3330	6810	7442	9588	
450	4410	8238	9074	13204	
530	5134	9664	11980	16902	
610	5872	11114	13606	20650	30006
690	6960	12542	15234	22010	35416
770	7684	13968	18186	25754	40854
850		16222	19806	29524	46310
930		17622	21428	30858	51778
1010		19048	24402	34620	57258
1090		20474	26018	35962	62748
1170		21900	27636	39720	68242
1250			30622	43494	73742
1330			32236	44822	79246
1410			33850	48590	84754
1490			36846	52372	90266
1570				56166	95780
1650				57466	101296
1730				61252	106814
1810				62562	112332
1890				66344	117854
1970				67658	123376

Tab. 51

Length [mm]	DS...				DSE				DSC
	28	35	43	63	28	35	43	63	43
	δ [N]								
290	1726				1084				
370	2328				1466				
450	2932	3784			1848	2390			
530	3536	5080	6240		2232	3224	3976		7194
610	4156	5756	7858	10656	2620	3650	5018	6690	8902
690	4762	6434	8394	12918	3004	4080	4792	8126	9322
770	5368	7762	10020	15208	3388	4934	6388	9578	11022
850	6360	8436	11672	17518	4028	5358	7452	11046	12746
930	6948	9110	12180	19842	4406	5784	7758	12526	13144
1010	7556	10452	13832	22178	4792	6650	8820	14012	15760
1090	8162	11122	15500	24522	5412	7072	9896	15504	16592
1170	8768	11794	15292	26874	5562	7496	10190	17002	17868
1250	9792	13146	17658	29232		8368	11264	18504	18702
1330	10386	13814	18154	31596		8790	11562	20010	19980
1410	10992	14484	19818	33962		9212	12632	15914	20818
1490	11612	15840	21492	36332		10088	13710	23028	23456
1570		16506	21976	38706			14096	24540	23826
1650		17176	23650	41080			15078	26056	24660
1730		18536	25330	43458			16160	27572	26394
1810			25808	45838			16444	29088	27824
1890			27486	48218			17526	30606	29408
1970			27966	50602			17814	32126	29770

Tab. 52

Length [mm]	DMS
	63
	δ [N]
770	
850	
930	
1010	24308
1090	29974
1170	28914
1250	32972
1330	33526
1410	39684
1490	38570
1570	44316
1650	43196
1730	49414
1810	47822
1890	51926
1970	52450
2050	58682
2130	57526
2210	61190

Tab. 53

Length [mm]	DE... / DBN				DE
	22	28	35	43	63
	δ [N]				
130	330	714			
210	772	1310	1228	1846	
290	1074	2306	2422	3374	
370	1380	2912	3104	3948	
450	1850	3518	3784	5528	
530	2150	4126	5080	7160	
610	2458	4744	5756	8828	12406
690	2934	5350	6434	9322	14722
770	3232	5958	7762	10986	17054
850		6974	8436	12670	19398
930		7566	9110	13144	21750
1010		8172	10452	14822	24110
1090		8776	11122	16514	26476
1170		9382	11794	16978	28846
1250			13146	18664	31220
1330			13814	19136	33596
1410			14484	20818	35974
1490			15840	22510	38356
1570				24210	40738
1650				24660	43122
1730				26356	45508
1810				26812	47896
1890				28504	50284
1970				28966	52672

Tab. 54

> Speed

The maximum operating speed is determined by the mass of the intermediate element, which moves with the movable rail. This reduces the maximum permissible operating speed with increasing length (see fig. 71).

Maximum acceleration: 1.2 m/s²

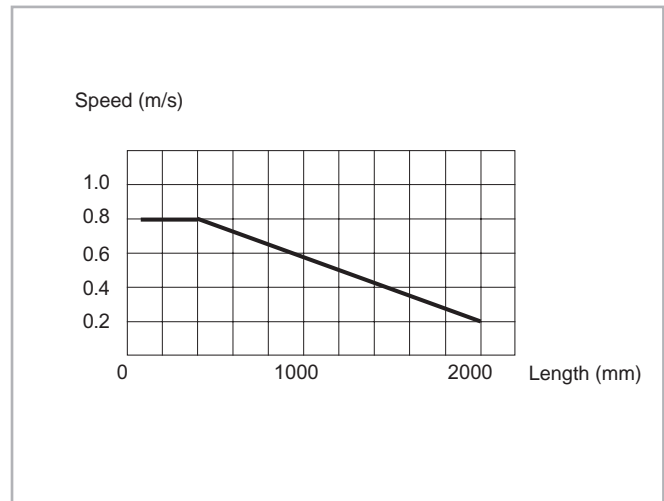

Fig. 71

> Opening and closing force

The required actuation forces of a telescopic rail depend on the acting load and the deflection in the extended state. The force required for opening is principally determined by the coefficient of friction of the linear bearing. With correct assembly and lubrication, this is 0.01. During the extension, the force is reduced with the elastic deflection of the loaded

telescopic rail. A higher force is required to close a telescopic extension, since, based on the elastic deflection, even if it is minimal, the movable rail must move against an inclined plane.

> Double-sided stroke

For all designs allowing double-sided stroke, it must be noted that the position of the intermediate element is defined only in the extended state. In the extended state, the intermediate element can protrude by half of its length on each side. Exception is the ASN series, which comes out as a partial extension without an intermediate element and the custom design of series DE with driving disc.

The double-sided stroke in the ASN, DE and DBN series is achieved by removing the set screw. For the DSD series, the double-sided stroke is implemented by design adaptation. Double-sided stroke for series DMS on request. The DSB series are not available with double-sided stroke.

> Temperature

- ASN, DE, DBN series can be used up to an ambient temperature of +170 °C (+338 °F). A lithium lubricant for high operating temperatures is recommended for temperatures above +130 °C (+266 °F). Minimum temperature with standard grease is -20 °C (-4 °F).
- The DS, DSE, DSC and DMS series have a useable range of -20 °C to +80 °C (-4 °F to +176 °F) due to of the rubber stop.
- The DSS43S and DE...S series have a temperature range of application from -20 °C to + 50 °C (-4 °F to 122 °F), due to the bumpers in special resin.

> Anticorrosive protection

- All of our Telescopic Rail series have a standard anticorrosive protection by electrolytic galvanisation according to ISO 2081. If a higher resistance to corrosion is required, the guides are available with Rollon Alloy or chemical nickel treatment. For both versions stainless steel balls are provided.
- Numerous application-specific surface treatments are available upon request, e.g., FDA approved nickel plating for use in the food industry. For more information please contact Rollon technical support.

> Lubrication

Recommended lubrication intervals are heavily dependent upon the ambient conditions, speed and temperature. Under normal conditions, lubrication is recommended after 100 km operational performance or after an operating period of six months. In critical application cases the interval should be shorter. Please clean the raceways carefully before lubricating. Raceways and spaces of the ball cage are lubricated with a lithium lubricant of average consistency (roller bearing lubricant).

Different lubricants are available on request for special applications:

- FDA-approved lubricant for use in the food industry
- specific lubricant for clean rooms
- specific lubricant for the marine technology sector
- specific lubricant for high and low temperatures

For specific information, contact Rollon technical support.

> Clearance and preload

Telescopic Rail guides are mounted as standard with no play. For more information, please contact Rollon technical support.

Preload classes		
Increased clearance	No clearance	Increased preload
G ₁	Standard	K ₁

Tab. 55

* for higher preload, contact Rollon technical support.

> Fixing screws

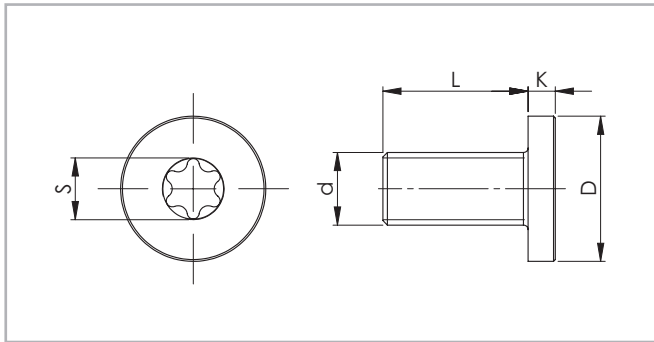

Fig. 72

The screws are included in the scope of supply. All other rails are fixed with counter-sunk or cap head screws as per DIN 7991 or 7984. In size 63 of the ASN and DMS series, Torx® screws with low head cap screws are available on request (see fig. 72).

Size	Screw type	d	D [mm]	L [mm]	K [mm]	S
63	M8 x 20	M8 x 1.25	13	20	5	T40
43	M8 x 16	M8 x 1.25	16	16	3	

Tab. 56

Recommended Standard fixing screw tightening torques

Property class	Size	Tightening torque [Nm]
10.9	22	3
	28	6
	35	10
	43	25
	63	30

Tab. 57

Prepare a sufficient bevel on the threaded fixing holes, according to the following table:

Size	Bevel (mm)
22	0.5 x 45°
28	1 x 45°
35	1 x 45°
43	1 x 45°
63	1 x 45°

Tab. 58

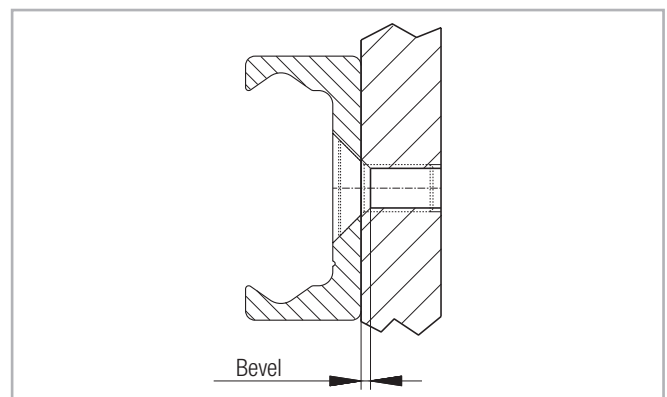
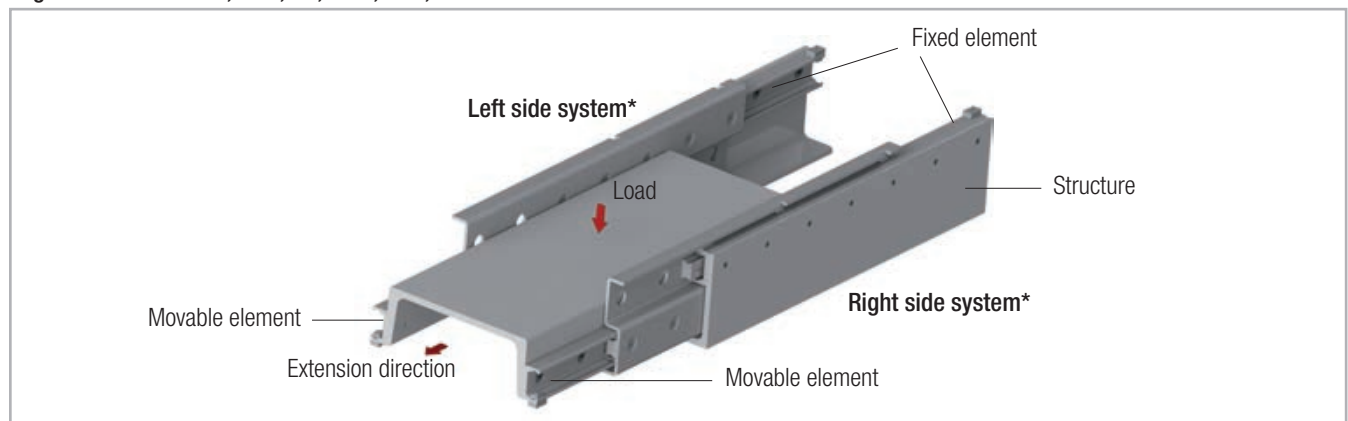

Fig. 73

> Installation instructions

In general and for ASN, DBN, DE, DMS, DSB, DSE



* For models DMS, DSB, and DSE, please observe right or left side use

Fig. 74

General

- Internal stops are used to stop the unloaded slider and the ball cage. Please use external stops as end stops for a loaded system.
- To achieve optimum running properties, high service life and rigidity, it is necessary to fix the telescopic rails with all accessible holes on a rigid and level surface.
- In order to reach all mounting holes for the ASN, DEV, DEM and DBN series it is necessary to remove the locking screw in the rail during assembly and then to reinsert it afterwards.
- Please observe the parallelism of the installation surfaces. The fixed and movable rails fit to the rigid assembly construction.
- Telescopic Rail guides are suitable for continuous use in automatic systems. For this, the stroke should remain constant in all moving cycles and the operating speed must be checked (see pg. TR-44, fig. 72). The movement of the telescopic rails is enabled by internal ballcages, which could experience an offset from the original position with differing strokes. This phase offset can have a negative effect on the running properties or limit the stroke. If differing strokes occur in an application, the drive force must be sufficiently dimensioned in order to appropriately synchronise the ballcage offset. Otherwise, an additional maximum stroke must be planned regularly to ensure the correct position of the ballcage.

ASN

- Series ASN accepts radial and axial loads and moments in all principle directions.
- Horizontal and vertical application is possible. Prior to vertical installation, we recommend contacting Rollon technical support.
- The installation of two partial extensions on a profile provides a load capable full extension. For individual solutions, please contact Rollon technical support.

DE / DBN

- Series DE and DBN accept radial and axial loads.
- Horizontal and vertical application is possible. Prior to vertical installation, we recommend you contact Rollon technical support.
- The functionality of custom design DE...D is only guaranteed if the stroke available is completely used.

DS / DSE / DMS

- Series DS, DES, DMS accept radial loads. This should act in the vertical cross-sectional axis on the movable rails.
- Horizontal and vertical application is possible. Prior to vertical installation, we recommend you contact Rollon technical support.
- When installing make sure that the load is placed on the movable element (the lower rail) (see fig. 74).
The opposite assembly negatively affects the function.
- Installation must be done on a rigid structure using all accessible fixing holes.
- Pay attention to the parallel alignment during assembly with paired application.

> Installation instructions

For DSC

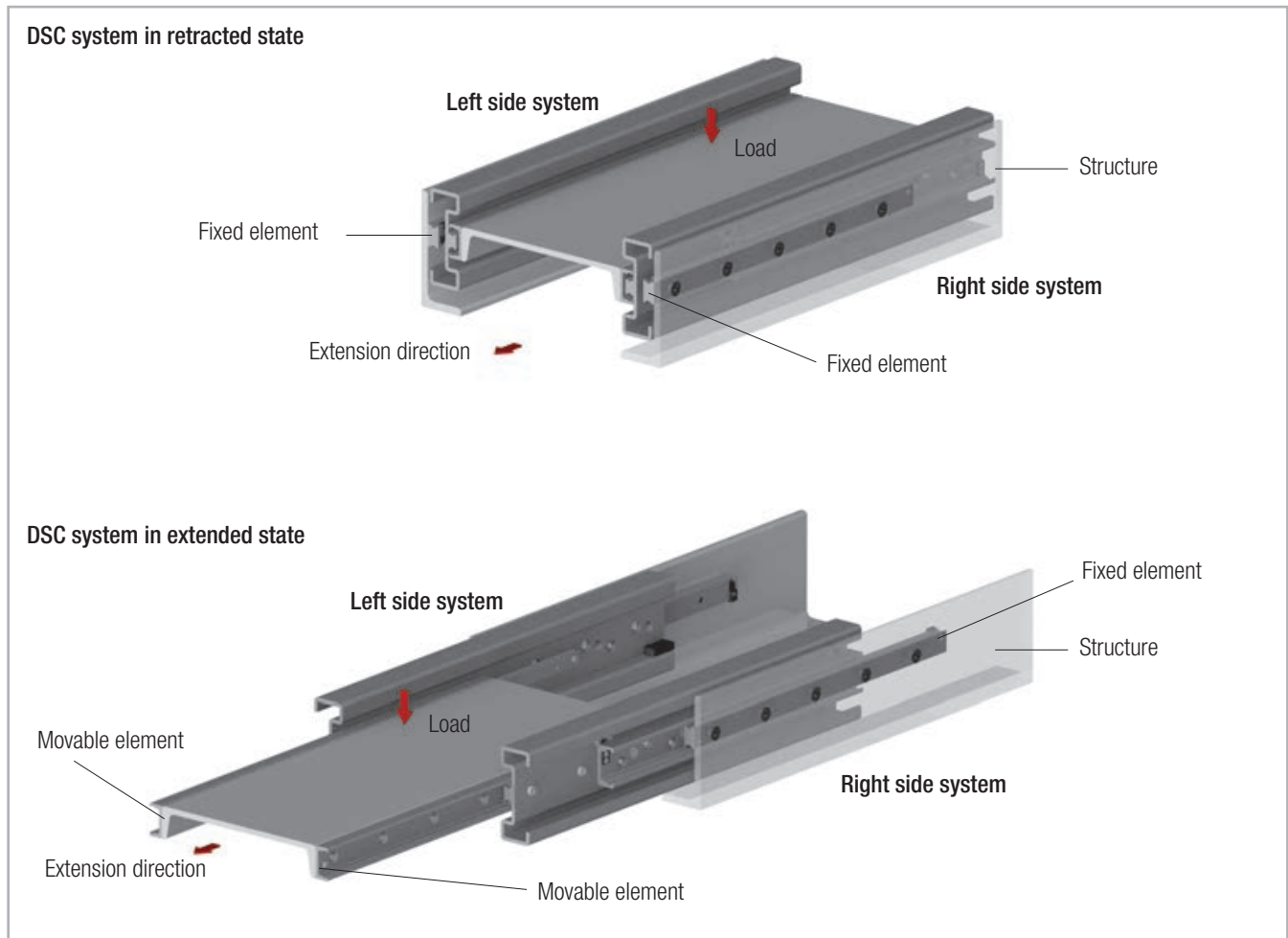

Fig. 75

DSC

- The DSC series absorbs radial and axial loads, in which case radial load directions are preferable.
- Horizontal and vertical use is possible. Prior to vertical installation we recommend inspection by the application engineers.
- During installation make sure that the load is mounted on the movable element (see Fig. 75). Reverse installation will impair proper functioning.
- The installation must be performed on a rigid structure, using all accessible mounting holes.
- Important: The length of the slider (fixed element) is different from the system length. See Table 23 on page TR-21 for DSC load ratings. The table also provides information on the accessible mounting holes.
- Important: The slide (fixed element) must be mounted in the front position when the system is retracted in order to achieve the entire stroke.
- Make sure the elements are aligned parallel during mounting.

Ordering key

> Telescopic rails

DSB	28	690	885	L	NIC
					Expanded surface protection is deviation from standard (ISO 2081) <i>see pg. TR-45, Anticorrosive protection</i>
					Right (R) or left (L) version (only for series DMS, DSB) <i>see pg. TR-7 Remarks</i>
					Stroke, if deviating from standard stroke (catalogue data) <i>see pg. TR-8ff Product dimensions and Ordering key for special strokes</i>
		Length			<i>see pg. TR-8ff Product dimensions</i>
	Size				<i>see pg. TR-8ff Product dimensions</i>
Product type					<i>see pg. TR-8ff Product dimensions</i>

Ordering example 1: ASN35-0770

Ordering example 2: DSB28-0690-0885-L-NIC

Ordering example 3 (rail DE...D): DEF28D-0690

Notes on ordering: Information for right and left side installation and for expanded surface protection is only necessary if required.

Rail lengths and stroke lengths are always stated with 4 digits. Please pad with zeroes to fill in for lengths with less than 4 digits, e.g. 515mm length is "0515"

> Special strokes

Special strokes are defined as deviations from standard stroke H. They are each available as multiples of the values in tab. 59 and 60.

These values are dependent on the spacing of the ballage.

Type	Size	Stroke modification [mm]
ASN	22	7.5
	28	9.5
	35	12
	43	15
	63	20

Tab. 59

Stroke modification of series DMS on request.

No stroke modification is possible for the DSD and DSC series. Each stroke modification influences the load capacities stated in the catalogue. It is possible that after a stroke modification important fastening holes might no longer be accessible. For more information please contact Rollon technical support.

Type	Size	Stroke modification [mm]
DSS DE DBN	22	15
	28	19
	35	24
	43	30
	63	40
DE...S	35	22
DSE	28	28.5
	35	36
	43	45
	63	60

Tab. 60

ROLLON[®]
BY TIMKEN

Hegra Rail



Product explanation



> Partial and full extension guides of different types



Fig. 1

The Hegra Rail product family consists of five product categories: partial, fully extending, overextending and heavy-duty rails as well as S-profiles. Different versions in the single categories, such as design or materials, also provide for increased customer benefits.

The most important characteristics:

- High load capacity and minimal deflection
- Different versions and materials
- Compact design
- Lightweight; smooth operation
- Long life
- High functional reliability

Preferred applications:

- Rail vehicles (maintenance and battery compartments)
- Motor vehicle technology
- Construction and machine technology
- Special purpose machinery

Partial extension guides

Partial extension guides with a stroke of more than 50 % of the closed telescoping length, consisting of one guide rail and one slider. The high system rigidity is achieved here in combination with the connection construction.



Fig. 2

Full extension guides

Full extension guides with strokes of about 100 % of the closed length consisting of three elements in different designs and sizes.



Fig. 3

Overextending guides

Overextending guides with a stroke of up to 200 % of the closed telescoping length. The use of intermediate elements with a high moment of inertia achieves excellent system rigidity and a high load capacity in fully extended systems.



Fig. 4

Heavy load extension guides

Full extension guides with strokes of about 100 % of the length consist of a solid, double T-shaped intermediate element and the two corresponding sliders. This full extension guide was specially designed for extremely heavy loads with minimal deflection and high system rigidity.



Fig. 5

S-profiles

Full extension guides with strokes of about 100 % of the closed length consisting of two guide rails and one S-shaped intermediate element. The advantages of the full extension guide are high rigidity and a compact design.



Fig. 6

H
R

Overview product cross sections



> Partial extension guides

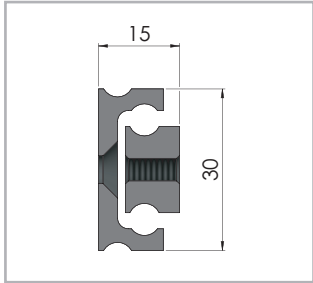

Fig. 7

HTT030

Load capacities p. HR-7

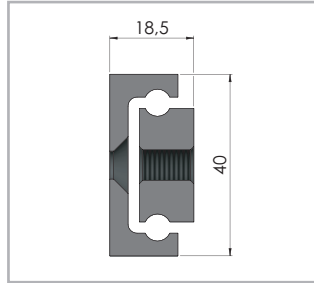

Fig. 8

HTT040

Load capacities p. HR-8

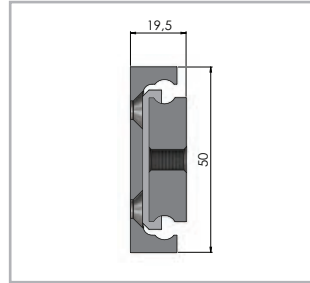

Fig. 9

HTT050

Load capacities p. HR-9

> Full extension guides

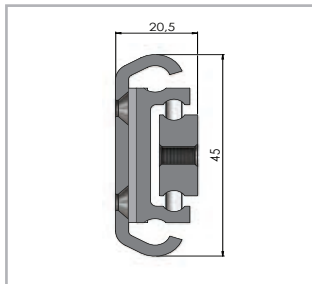

Fig. 10

HVC045

Load capacities p. HR-11

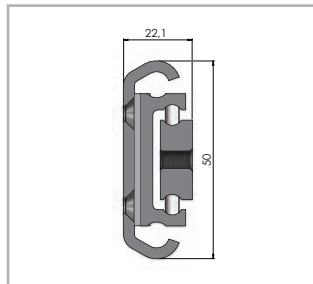

Fig. 11

HVC050

Load capacities p. HR-12

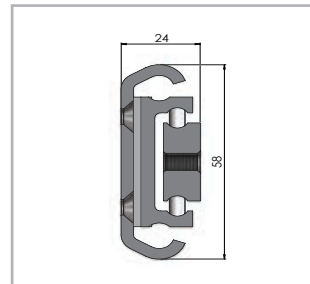

Fig. 12

HVC058

Load capacities p. HR-13

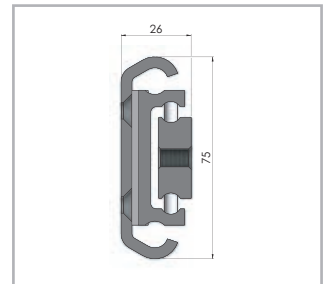

Fig. 13

HVC075

Load capacities p. HR-14

> Overextending guides

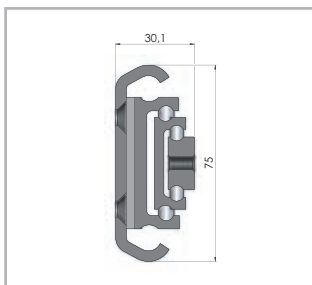

Fig. 14

H1C075

Load capacities p. HR-16

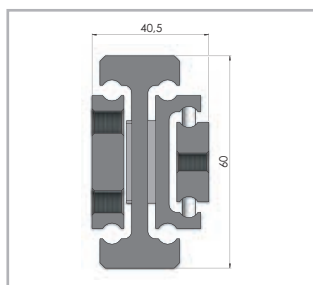

Fig. 15

H1T060

Load capacities p. HR-18

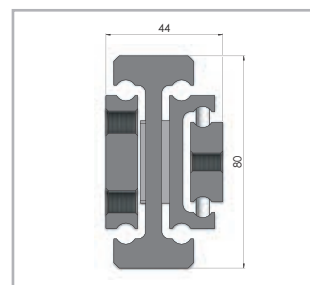

Fig. 16

H1T080

Load capacities p. HR-19

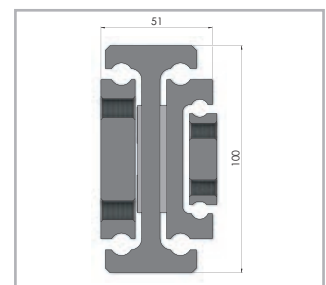

Fig. 17

H1T100

Load capacities p. HR-20

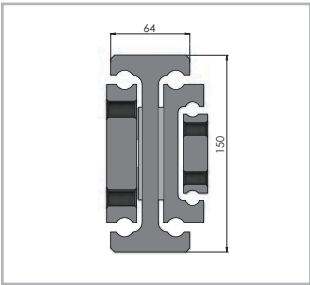

Fig. 18

H1T150

Versions are available on request
Load capacities p. HR-21

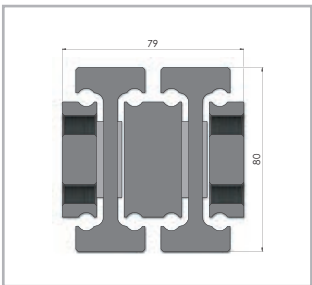

Fig. 19

H2H080

Load capacities p. HR-22

> **Heavy load extension guides**

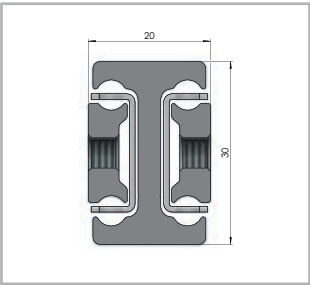

Fig. 20

LTH30

Load capacities p. HR-24

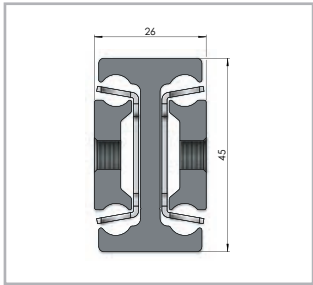

Fig. 21

LTH45

Load capacities p. HR-27

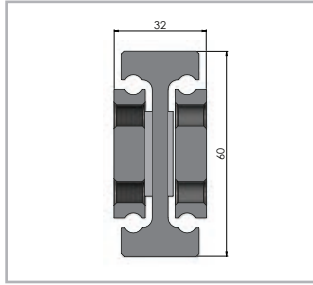

Fig. 22

HGT060

Load capacities p. HR-31

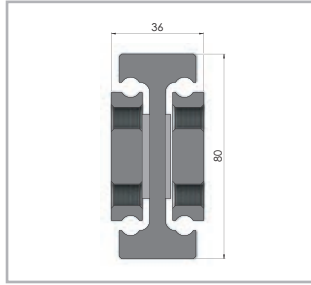

Fig. 23

HGT080

Load capacities p. HR-32

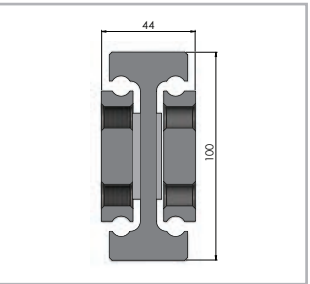

Fig. 24

HGT100

Load capacities p. HR-33

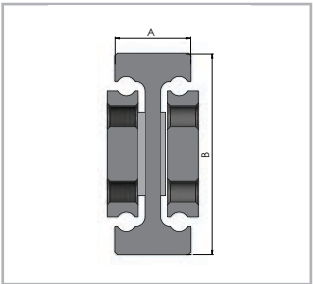

Fig. 25

HGT120, HGT150, HGT200, HGT240

Versions are available on request
Load capacities p. HR-33

- HGT120: A = 44, B = 120
- HGT 150: A = 56, B = 150
- HGT 200: A = 72, B = 200
- HGT 240: A = 74, B = 240

> **S-profiles**

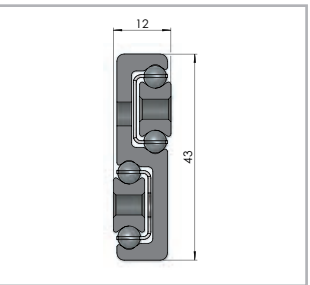

Fig. 26

LTF44

Load capacities p. HR-35

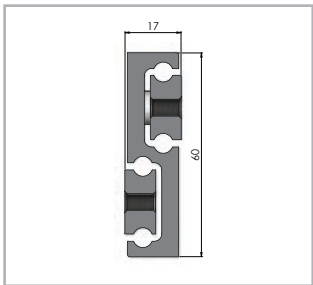

Fig. 27

HGS060

Load capacities p. HR-37

Technical data

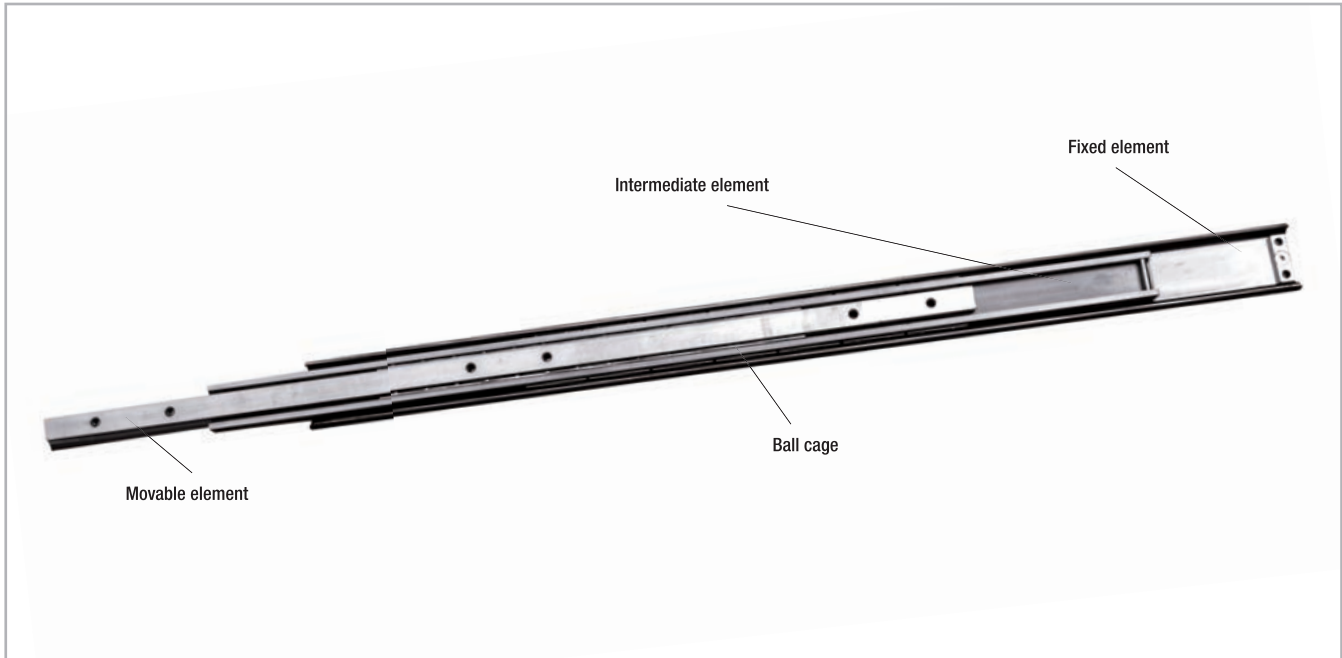

Fig. 28

Performance characteristics:

- Temperature range: -20 °C to +170 °C (-4 °F to +338 °F)
(in exceptions also -30 °C to +250 °C (-22 °F to +482 °F))
- Max. operating speed 0.8 m/s (depending on the application)
- Different materials and anti-corrosion coatings are available
- Special solutions, such as locking mechanisms, catches, damping elements or are available on request

Attention!

The load capacity for aluminum is 40 % and for stainless steel 60 % of the stated values, if available in this material variant.

Notes:

- Horizontal movement installation is recommended
- Vertical movement installation on request
- Special strokes on request
- All load capacities refer to one telescopic pair
- Mounting screws with a strength class of 10.9 must be used for all telescopic rails
- Internal stops are provided to stop the sliders when not under load and the ball cage. Please use external stops as limit stops for a system under load
- Not all accessories (interlocks, damping, drive disk, snap) can be combined with each other. Please contact our technical service.
- For models HGT with locking please observe right or left side use.
- Temperature range: LTH
-20 °C to +170 °C (-4 °F to +338 °F)
- Temperature range: LTH ...S
-20 °C to +50 °C (-4 °F to +122 °F)
- Telescopic guides made of aluminum or stainless steel are standard without greasing. If a greasing is desired, it must be stated separately at the order.
- Please note eventually dimensional variations in use of stainless steel. Please contact our technical service.

Load capacities and dimensions

> HTT030

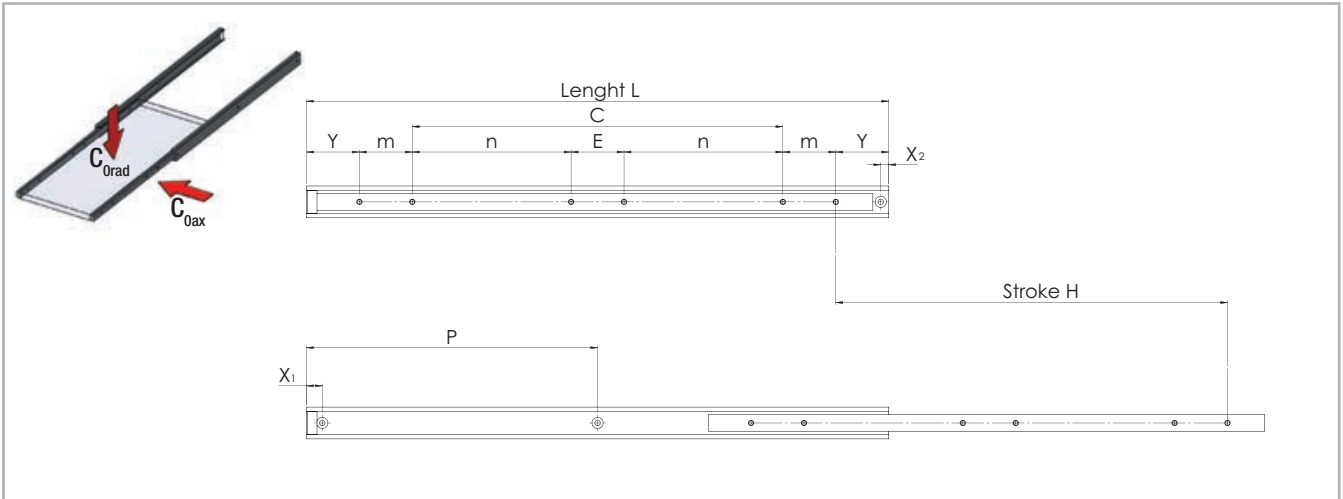

All dimensions are indicated in mm

Fig. 29

Type	Size	Length L [mm]	Stroke H [mm]	Load capacity per pair		X1*	X2	Y	m	n	E	C	P	Number of holes
				C _{Orad} [N]	C _{Oax} [N]									
HTT	30	250	130	1100	on request	15	7.5	50	50	-	-	50	125	4
		300	180	1200								100	150	
		350	230	1150								150	175	
		400	260	1100								200	200	
		450	310	1050								250	225	
		500	340	1000								300	250	
		550	370	950								150	275	6
		600	400	900								175	300	
		650	430	850								200	325	
		700	460	800								225	350	
		750	490	750								250	375	
		800	520	700								275	400	
		850	550	650								300	425	
		900	600	600								325	450	
		950	630	550								350	475	
		1000	660	500								375	500	

The load capacity for aluminum is 40% and for stainless steel 60% of the stated values, if available in this material variant (see Technical features overview).

* For double-sided stroke the dimension X1=7,5mm

Tab. 1

> **HTT040**

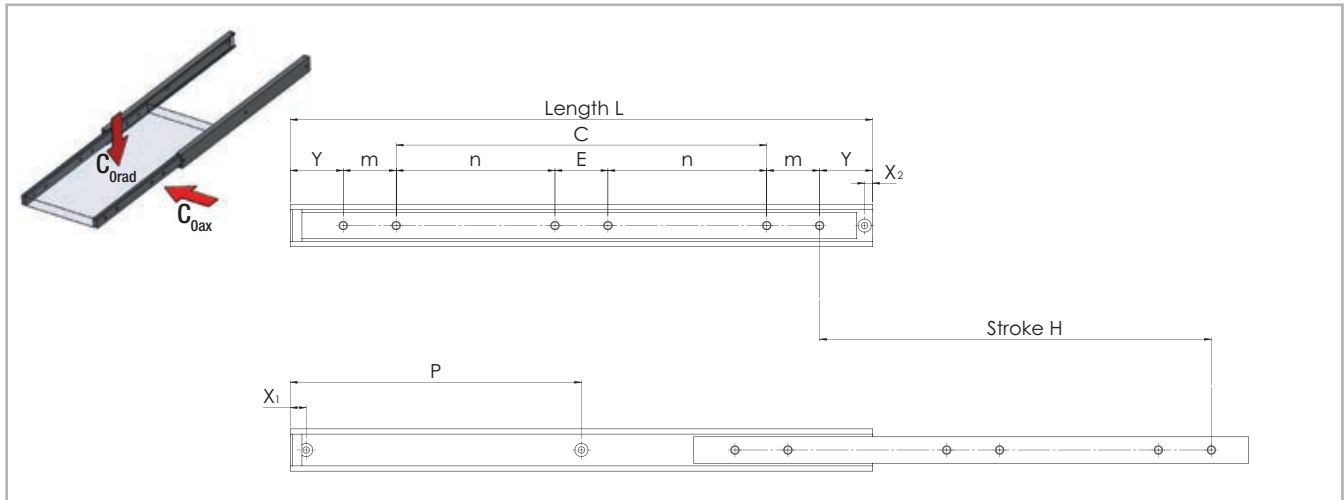

All dimensions are indicated in mm

Fig. 30

Type	Size	Length L [mm]	Stroke H [mm]	Load capacity per pair		X1*	X2	Y	m	n	E	C	P	Number of holes
				C _{Orad} [N]	C _{Oax} [N]									
HTT	40	250	130	2100	on request	15	7.5	50	50	-	-	50	125	4
		300	180	2250								100	150	
		350	230	2350								150	175	
		400	260	2450								200	200	
		450	310	2550								250	225	
		500	340	2500								300	250	
		550	370	2450								150	275	6
		600	400	2400								175	300	
		650	430	2350								200	325	
		700	460	2300								225	350	
		750	490	2250								250	375	
		800	520	2150								275	400	
		850	550	2050								300	425	
		900	600	1950								325	450	
		950	630	1800								350	475	
		1000	660	1650								375	500	

The load capacity for aluminum is 40% and for stainless steel 60% of the stated values, if available in this material variant (see Technical features overview).

* For double-sided stroke the dimension X1=7,5mm

Tab. 2

> HTT050

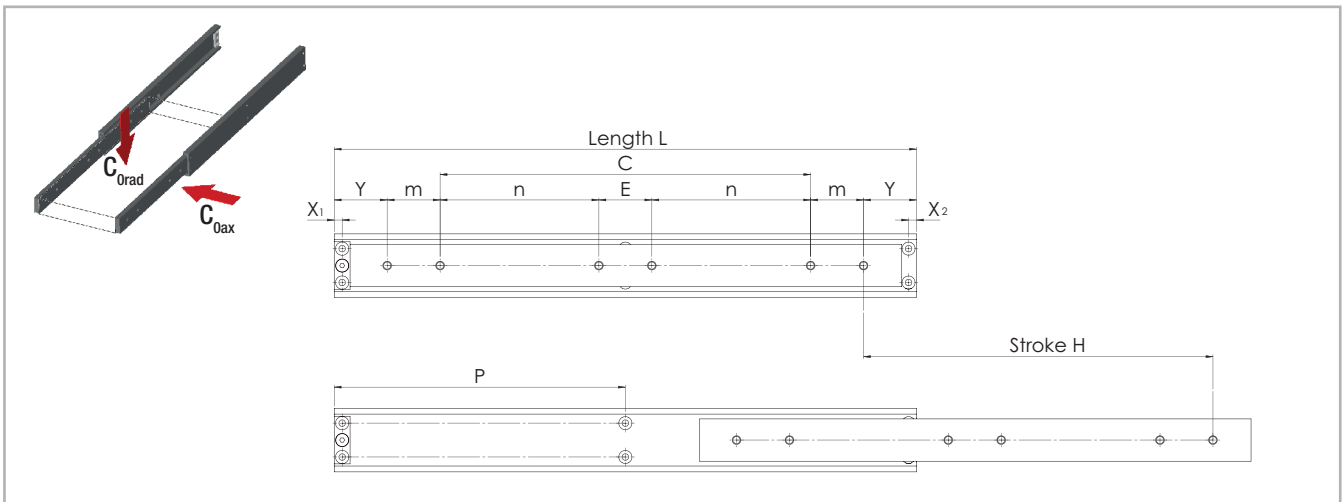

All dimensions are indicated in mm

Fig. 31

Type	Size	Length L [mm]	Stroke H [mm]	Load capacity per pair		X1*	X2	Y	m	n	E	C	P	Number of holes
				C _{Orad} [N]	C _{Oax} [N]									
HTT	50	300	180	2500	on request	15	7.5	50	50	-	-	100	150	4
		350	230	2600								150	175	
		400	260	2700								200	200	
		450	310	2800								250	225	
		500	340	2900								300	250	6
		550	370	2850								150	275	
		600	400	2800								175	300	
		650	430	2700								200	325	
		700	460	2600								225	350	
		750	490	2500								250	375	
		800	520	2400								275	400	
		850	550	2300								300	425	
		900	600	2200								325	450	
		950	630	2100								350	475	
		1000	660	2000								375	500	
		1100	700	1850								425	525	
1200	760	1650	475	550										

The load capacity for aluminum is 40% and for stainless steel 60% of the stated values, if available in this material variant (see Technical features overview).
 * For double-sided stroke the dimension X1=7,5mm

Tab. 3

> **HTT**

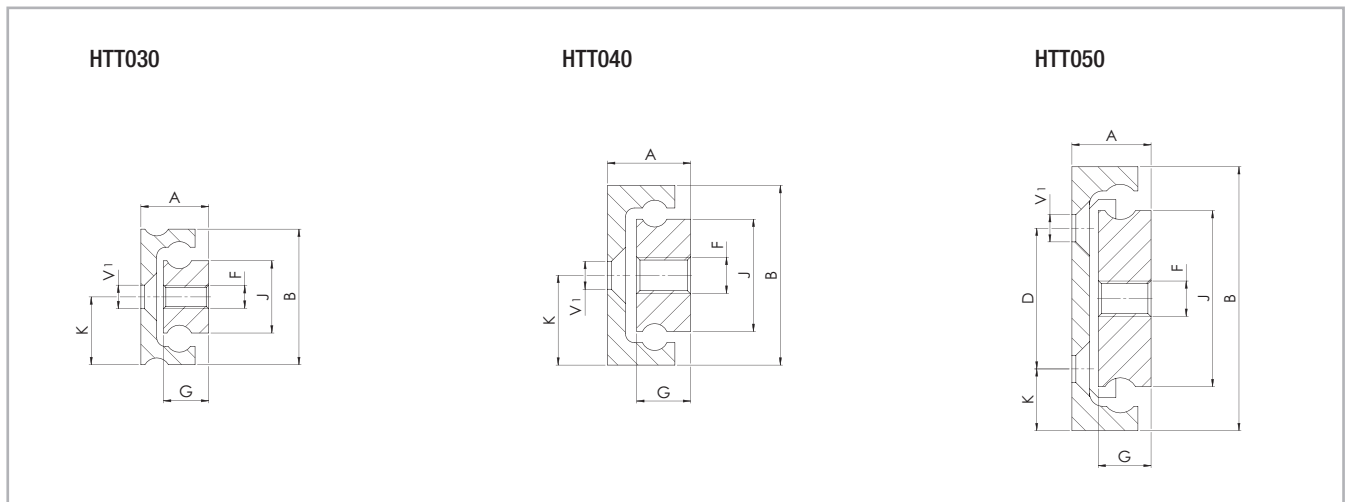

All dimensions are indicated in mm
 * Mounting holes (V) for countersunk screws according to DIN 7991/ISO 10642

Fig. 32

Type	Size	A	B	J	G	K	D	D1	F	V1	Weight per single guide [kg/m]
HTT	30	15	30	16	10	15	-	-	M6	M5	2.4
	40	18.5	40	25	12	20	-	-	M8	M6	4.3
	50	19.5	50	30	12.5	25	25	5.6			

Tab. 4

> HVC045, HVC050, HVC058, HVC075

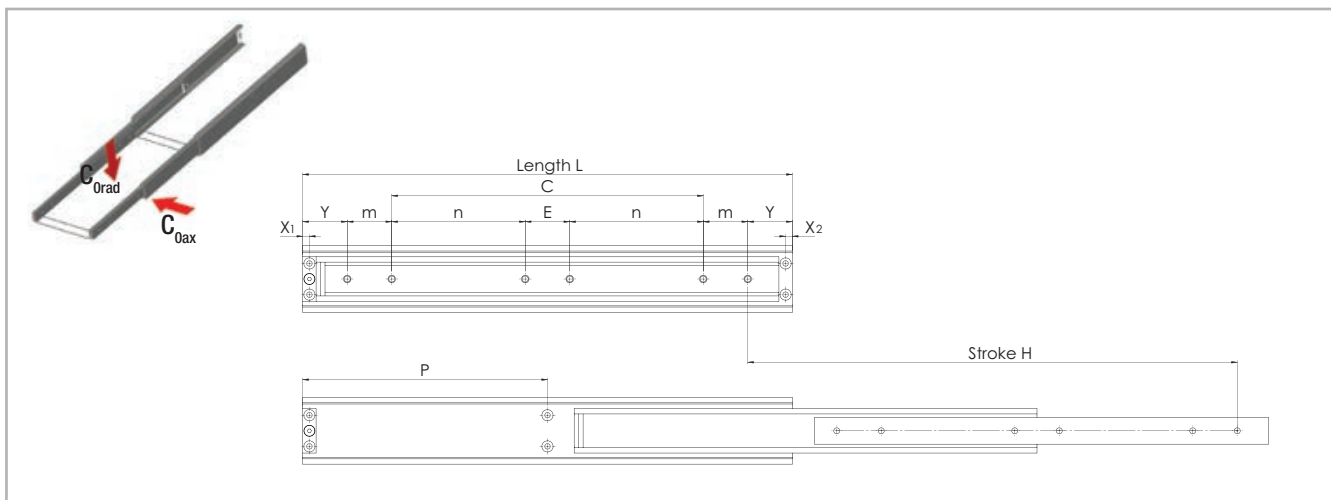

All dimensions are indicated in mm

Fig. 33

Type	Size	Length L [mm]	Stroke H [mm]	Load capacity per pair		X1	X2	Y	m	n	E	C	P	Number of holes
				C _{Orad} [N]	C _{Oax} [N]									
HVC	45	300	300	1150	on request	7.5	7.5	50	50			100		4
		350	350	1200								150		
		400	400	1200								200		
		450	450	1150								250		
		500	500	1150								300		
		550	550	1100								-	275	
		600	600	1050								150	300	
		650	650	1000								175	325	
		700	700	950								200	350	
		750	750	900								225	325	
		800	800	850								250	325	
		850	850	800								275	400	
		900	900	750								300	425	
		950	950	700								325	475	
		1000	1000	650								350	500	
		1100	1100	500								375	50	
1200	1200	400	425	600										
				475	-									6

The load capacity for aluminum is 40% and for stainless steel 60% of the stated values, if available in this material variant (see Technical features overview).

Tab. 5

H
R

4 Load capacities and dimensions

Type	Size	Length	Stroke	Load capacity per pair		X1	X2	Y	m	n*	E*	C	P	Number of holes	
				C _{Grad} [N]	C _{Oax} [N]										
HVC	50	300	300	1400	on request	7.5	7.5	50	50	-	-	100	-	4	
		350	350	1450								150			
		400	400	1500								200			
		450	450	1450								250			
		500	500	1400								300			
		550	550	1350								150			275
		600	600	1300								175			300
		650	650	1250								200			325
		700	700	1200								225			350
		750	750	1150								250			325
		800	800	1100								275			400
		850	850	1050								300			425
		900	900	1000								325			450
		950	950	950								350			475
		1000	1000	900								375			500
		1100	1100	800								425			550
		1200	1200	700								475			600
		1300	1300	600								525			650
		1400	1400	500								575			700
		1500	1500	400								625			750

The load capacity for aluminum is 40 % and for stainless steel 60 % of the stated values, if available in this material variant (see Technical features overview).

*When using full telescopes with interlocks in the open state (VO) or with interlocks open and closed (VB) the following measures change:
n reduces by 35 mm - E increases to 120 mm.

Tab. 6

Type	Size	Length	Stroke	Load capacity per pair		X1	X2	Y	m	n*	E*	C	P	Number of holes	
				C _{Orad} [N]	C _{Oax} [N]										
HVC	58	300	300	2000	on request	7.5	7.5	50	50	-	-	100	-	4	
		350	350	2050								150			
		400	400	2100								200			
		450	450	2050								250			
		500	500	2000								300			
		550	550	1950								150		275	6
		600	600	1900								175		300	
		650	650	1850								200		325	
		700	700	1800								225		350	
		750	750	1750								250		325	
		800	800	1700								275		400	
		850	850	1650								300		425	
		900	900	1600								325		450	
		950	950	1500								350		475	
		1000	1000	1450								375		500	
		1100	1100	1350								425		550	
		1200	1200	1250								475		600	
		1300	1300	1150								525		650	
		1400	1400	1050								575		700	
		1500	1500	1000								625		750	

The load capacity for aluminum is 40% and for stainless steel 60% of the stated values, if available in this material variant (see Technical features overview).

*When using full telescopes with interlocks in the open state (VO) or with interlocks open and closed (VB) the following measures change:
n reduces by 35 mm - E increases to 120 mm.

Tab. 7

4 Load capacities and dimensions

Type	Size	Length	Stroke	Load capacity per pair		X1	X2	Y	m	n*	E*	C	P	Number of holes
				C _{Grad} [N]	C _{Max} [N]									
HVC	75	300	300	3200	on request	7.5	7.5	50	50	-	-	100	-	4
		350	350	3250								150		
		400	400	3300								200		
		450	450	3250								250		
		500	500	3200								300		
		550	550	3150						150	50	-	275	6
		600	600	3100						175			300	
		650	650	3050						200			325	
		700	700	3000						225			350	
		750	750	2950						250			325	
		800	800	2900						275			400	
		850	850	2850						300			425	
		900	900	2800						325			450	
		950	950	2750						350			475	
		1000	1000	2700						375			500	
		1100	1100	2600						425			550	
		1200	1200	2500						475			600	
		1300	1300	2350						525			650	
		1400	1400	2200						575			700	
		1500	1500	2050						625			750	
1600	1600	1900	675	800										
1700	1700	1750	725	50										
1800	1800	1600	775	900										
1900	1900	1450	825	950										
2000	2000	1300	875	1000										

The load capacity for aluminum is 40 % and for stainless steel 60 % of the stated values, if available in this material variant (see Technical features overview).

*When using full telescopes with interlocks in the open state (VO) or with interlocks open and closed (VB) the following measures change:
n reduces by 35 mm - E increases to 120 mm.

Tab. 8

> HVC

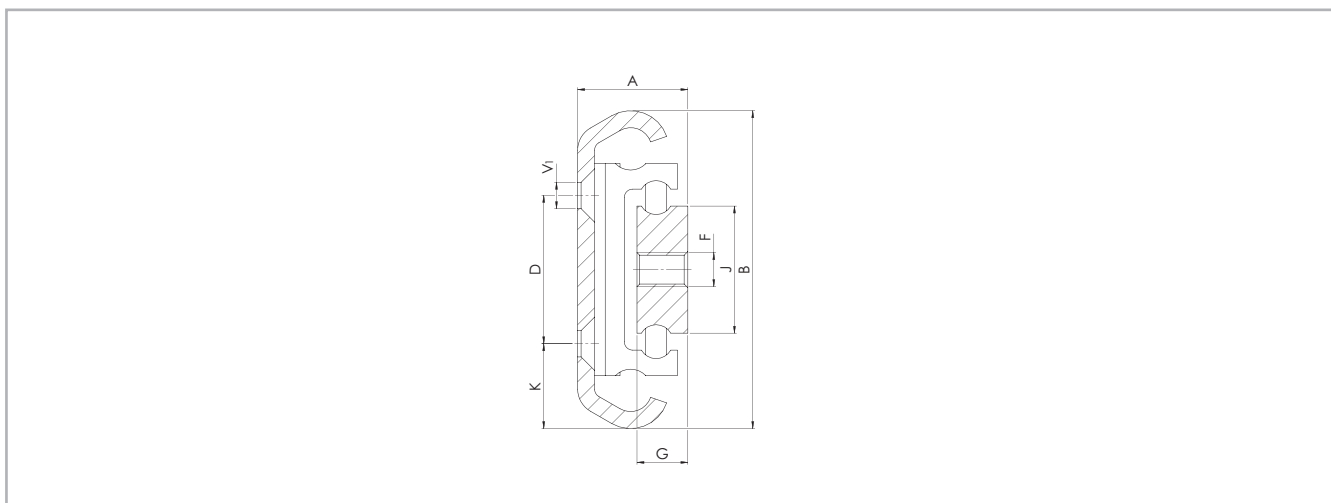

Fig. 34

All dimensions are indicated in mm
 V¹ Mounting holes (V) for countersunk screws according to DIN 7991/ISO 10642

Type	Size	A	B	J	G	K	D	F	V1	Weight per single guide [kg/m]
HVC	45	20.5	45	16	10	11.5	22	M6	M5	4.00
	50	22.1	50	20	12	14				5.10
	58	24	58	25		20	13	32	M8	M6
	75	26	75	30	20		35	9.30		

Tab. 9

H
R

H1C075

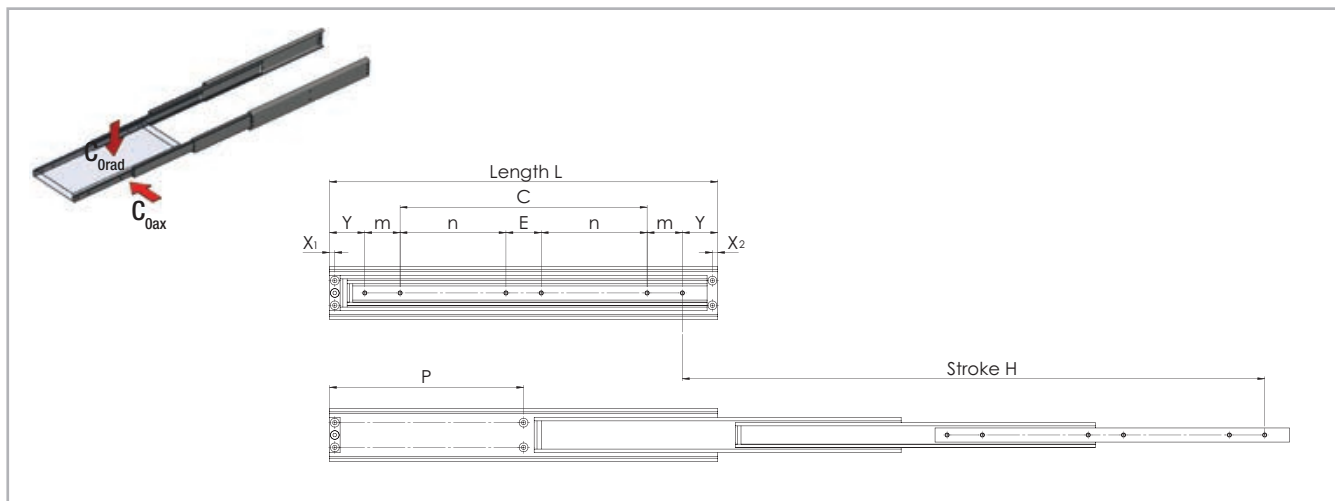

All dimensions are indicated in mm

Fig. 35

Type	Size	Length	Stroke	Load capacity per pair C_{Orad} [N]	X1	X2	Y	m	n	E	C	P	Number of holes
		L [mm]	H [mm]										
H1C	75	300	450	1200	7.5	7.5	50	50		50	100		4
		350	525	1250							150		
		400	600	1300							200		
		450	675	1350							250		
		500	750	1300							300		
		550	825	1200							150	275	6
		600	900	1150							175	300	
		650	975	1100							200	325	
		700	1050	1050							225	350	
		750	1125	1000							250	325	
		800	1200	950							275	400	
		850	1275	900							300	425	
		900	1350	850							325	450	
		950	1425	800							350	475	
		1000	1500	750							375	500	
		1100	1650	650							425	550	
		1200	1800	550							475	600	
		1300	1950	450							525	650	
		1400	2100	350							575	700	
		1500	2250	200							625	750	

The load capacity for aluminum is 40% and for stainless steel 60% of the stated values, if available in this material variant (see Technical features overview).

Tab. 10

> H1C075

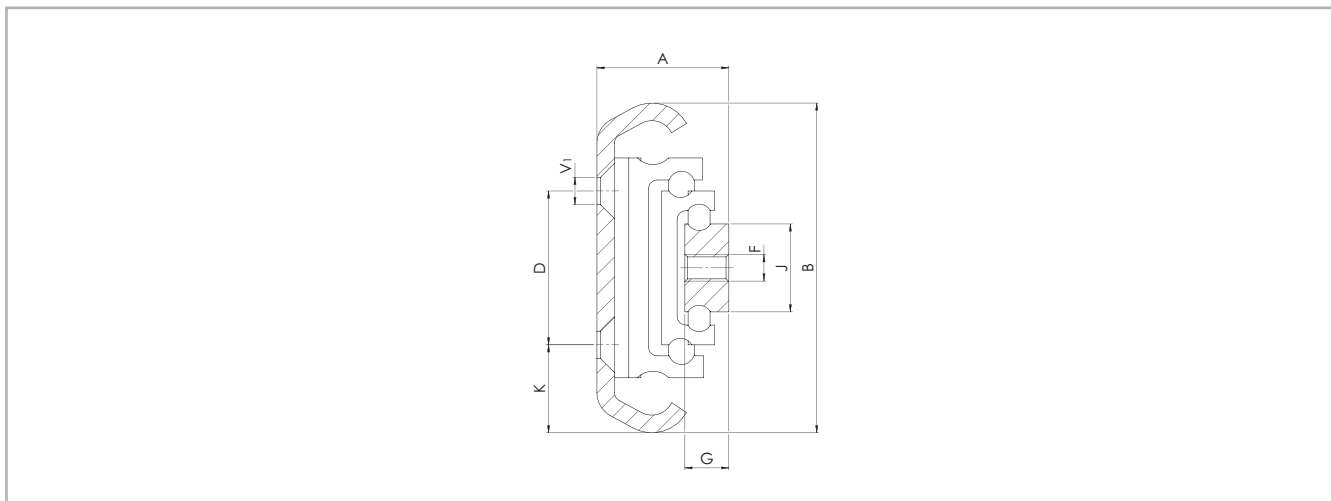

Fig. 36

All dimensions are indicated in mm
 V¹ Mounting holes (V) for countersunk screws according to DIN 7991/ISO 10642

Type	Size	A	B	J	G	K	D	F	V1	Weight per single guide [kg/m]
H1C	75	30	75	20	10	20	35	M6	M6	8.60

Tab. 11

> H1T060, H1T080

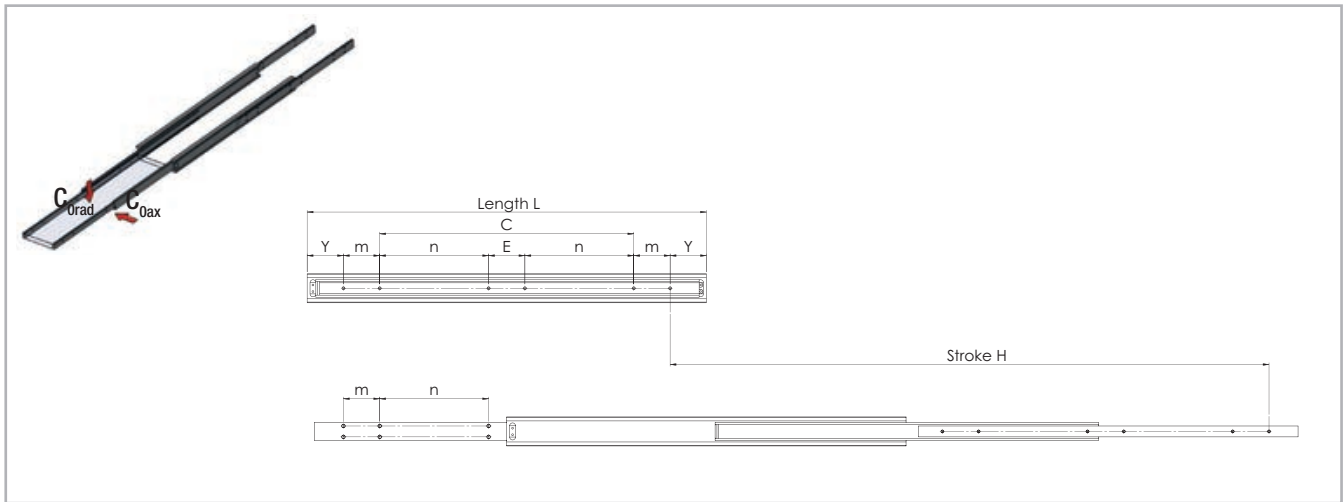

All dimensions are indicated in mm

Fig. 37

Type	Size	Length L [mm]	Stroke H [mm]	Load capacity per pair C_{Orad} [N]	Y	m	n	E	C	Number of holes		
										M6	M8	
H1T	60	300	450	2400	50	50				100	8	4
		350	525	2500						150		
		400	600	2550						200		
		450	675	2600						250		
		500	750	2600						300		
		550	825	2550			150	50	-	-	12	6
		600	900	2500			175					
		650	975	2450			200					
		700	1050	2400			225					
		750	1125	2350			250					
		800	1200	2300			275					
		850	1275	2250			300					
		900	1350	2200			325					
		950	1425	2150			350					
		1000	1500	2100			375					
		1100	1650	2000			425					
		1200	1800	1850			475					
		1300	1950	1700			525					
		1400	2100	1550			575					
		1500	2250	1400			625					

The load capacity for aluminum is 40% and for stainless steel 60% of the stated values, if available in this material variant (see Technical features overview).

Tab. 12

Type	Size	Length	Stroke	Load capacity per pair	Y	m	n	E	C	Number of holes		
		L [mm]	H [mm]	C _{0rad} [N]						M8	M10	
H1T	80	500	750	3100	100	100				100	4	8
		550	825	3150						150		
		600	900	3200						200		
		650	975	3150						250		
		700	1050	3100						300		
		750	1125	3000						350		
		800	1200	2900						400		
		850	1275	2800						450		
		900	1350	2700						500		
		950	1425	2600						550		
		1000	1500	2500			600					
		1100	1650	2280			300					
		1200	1800	2060			350					
		1300	1950	1840			400					
		1400	2100	1620			450					
		1500	2250	1400			500					
							100	-		6	12	

The load capacity for aluminum is 40% and for stainless steel 60% of the stated values, if available in this material variant (see Technical features overview).

Tab. 13

> H1T100, H1T150

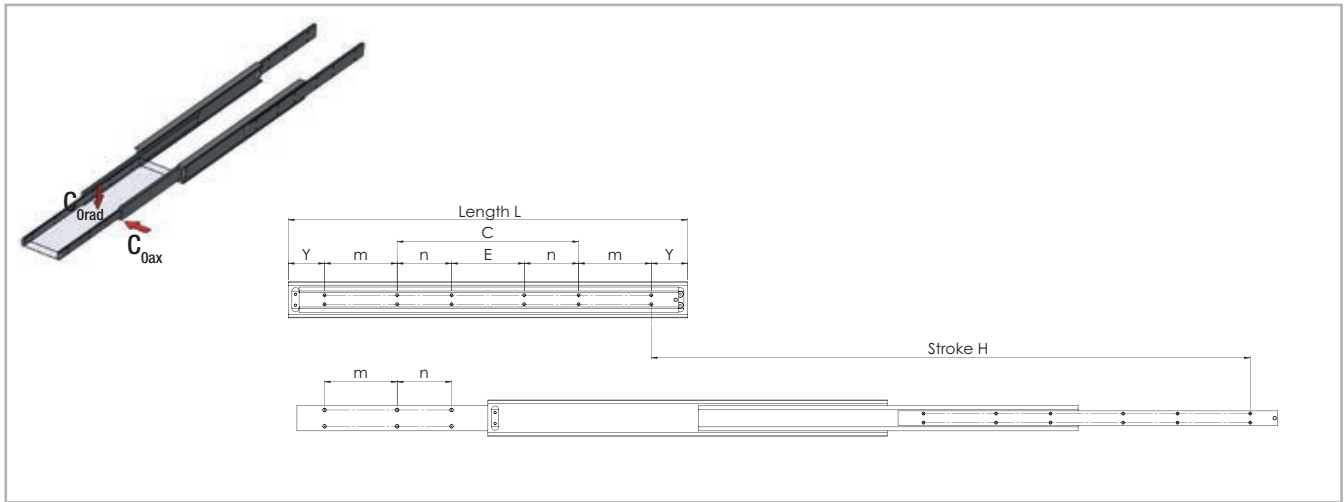

All dimensions are indicated in mm

Fig. 38

Type	Size	Length		Load capacity per pair C_{Orad} [N]	Y	m	n	E	C	Number of holes
		L [mm]	H [mm]							
H1T	100	700	1050	5500	100	200	-	-	100	8
		750	1125	5500					150	
		800	1200	5300					200	
		850	1275	5100					250	
		900	1350	4700					300	
		950	1425	4500					350	
		1000	1500	4300					400	
		1100	1650	4000					150	
	1200	1800	3700	200						
	1300	1950	3400	250						
	1400	2100	3100	300						
	1500	2250	2900	350						
	1600	2400	2600	400						
	1700	2550	2300	450						
	1800	2700	2000	500						
	1900	2850	1700	550						
	2000	3000	1400	600						

The load capacity for aluminum is 40% and for stainless steel 60% of the stated values, if available in this material variant (see Technical features overview).

Tab. 14

Other sizes and versions are available on request

Type	Size	Length	Load capacity
		L [mm]	per pair C_{0rad} [N]
H1T	150	700	7000
		⋮	⋮
		2000	2300

Tab. 15

The load capacity for aluminum is 40 % and for stainless steel 60 % of the stated values, if available in this material variant (see Technical features overview).

> H1T

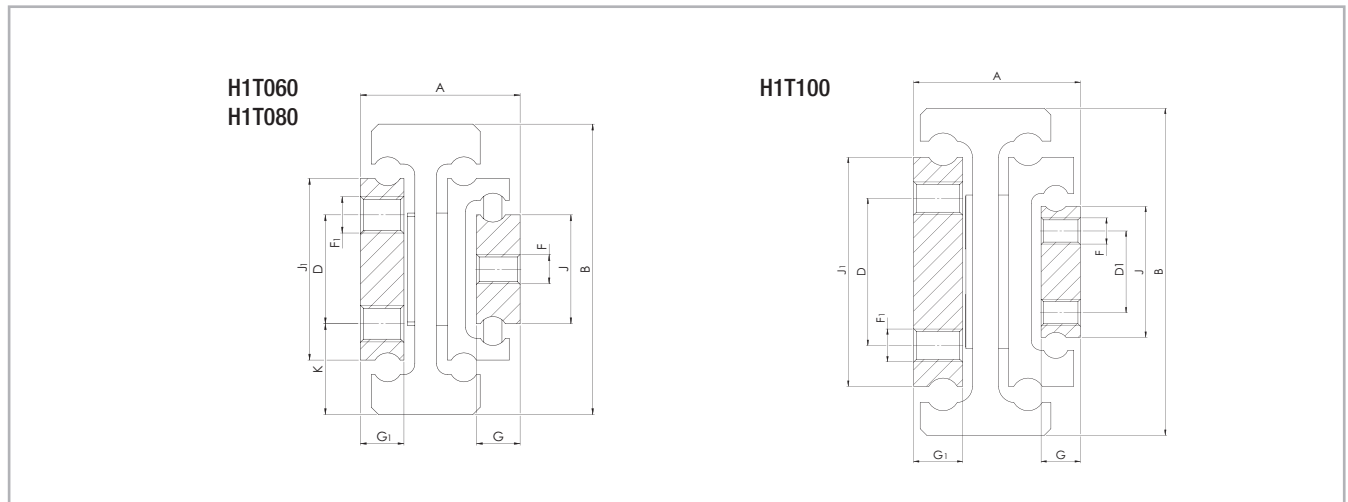

All dimensions are indicated in mm

Fig. 39

Type	Size	A	B	J	J1	G	G1	K	D	D1	F	F1	Weight per single guide [kg/m]
H1T	60	40.5	60	25	40	12	10	19	22	-	M8	M6	12.90
	80	44	80	30	50		12	25	30			M10	18.60
	100	51	100	40	70		15	27.5	45			25	M10

Tab. 16

> H2H080

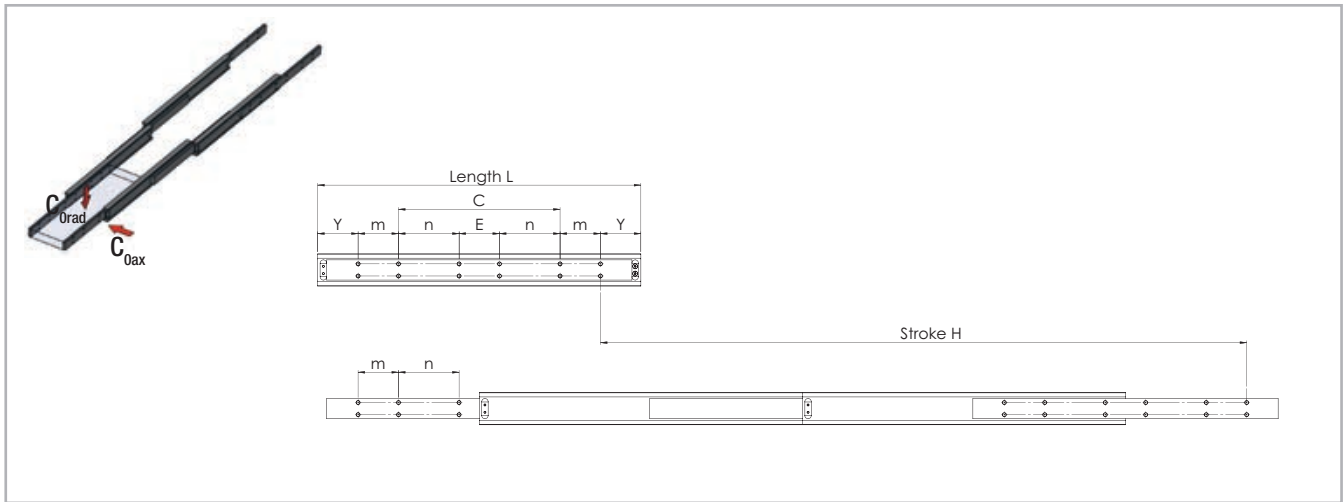

All dimensions are indicated in mm

Fig. 40

Type	Size	Length	Stroke	Load capacity per pair C_{0rad} [N]	Y	m	n	E	C	Number of holes
		L [mm]	H [mm]							
H2H	80	500	1000	on request	100	100	-	-	100	8
		550	1100						150	
		600	1200						200	
		650	1300						250	
		700	1400						300	
		750	1500						350	
		800	1600				150	100	-	12
		850	1700				175			
		900	1800				200			
		950	1900				225			
		1000	2000				250			
		1100	2200				300			
		1200	2400				350			
		1300	2600				400			
		1400	2800				450			
		1500	3000				500			

The load capacity for aluminum is 40% and for stainless steel 60% of the stated values, if available in this material variant (see Technical features overview).

Tab. 17

> H2H080

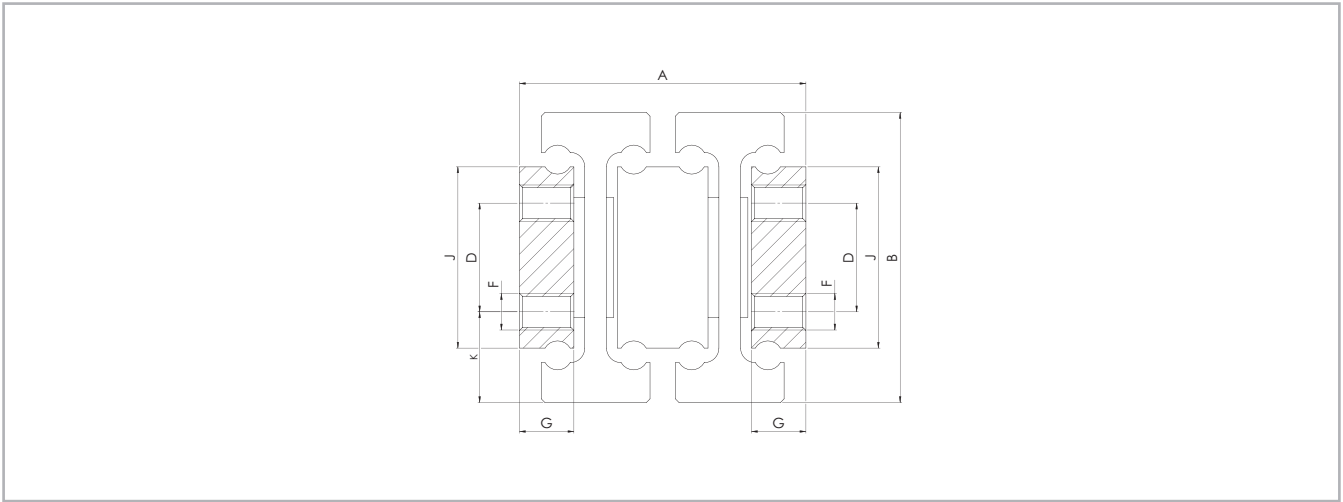

All dimensions are indicated in mm

Fig. 41

Type	Size	A	B	J	G	K	D	F	Weight per single guide [kg/m]
H2H	80	79+ -1	80	50	15	25	30	M10	34.80

Tab. 18

> LTH30 RF

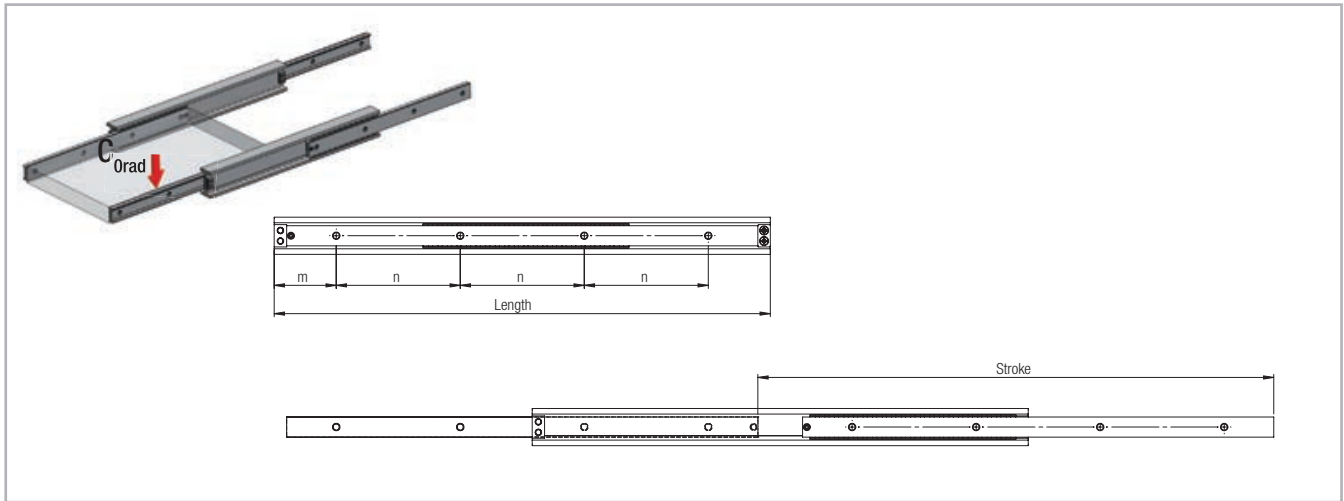

Fig. 42

Type	Size	Length		Load capacity per pair		m [mm]	n [mm]	Number of holes
		L [mm]	H [mm]	C _{Orad} [N]	C _{Oax} [N]			
LTH	30	250	285	404	on request	25	100	3
		300	323	1008		50		
		350	377	1042		25		4
		400	416	1136		50		
		450	485	1164		25		5
		500	523	1470		50		
		550	577	1464		25		6
		600	615	1402		50		
		650	685	1230		25		7
		700	723	1186		50		
		750	777	1100		25		8
		800	815	1066		50		
		850	884	962		25		9
		900	923	936		50		
		950	977	882		25		10
		1000	1015	858		50		
1050	1084	792	25	11				
1100	1123	772	50					
1150	1176	736	25	12				
1200	1215	720	50					

Tab. 19

> LTH30 KF

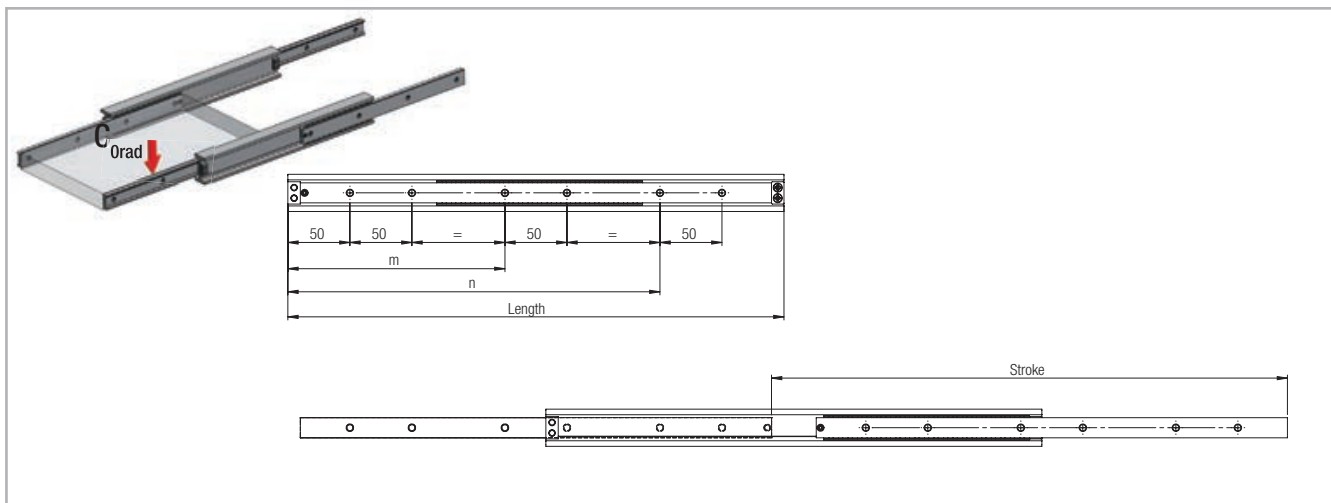

Fig. 43

Type	Size	Length L [mm]	Stroke H [mm]	Load capacity per pair		m [mm]	n [mm]	Number of holes
				C_{Orad} [N]	C_{Oax} [N]			
LTH	30	250	285	404	on request	-	150	4
		300	323	1008			200	
		350	377	1042			250	
		400	416	1136		175	300	6
		450	485	1164		200	350	
		500	523	1470		225	400	
		550	577	1464		250	450	
		600	615	1402		275	500	
		650	685	1230		300	550	
		700	723	1186		325	600	
		750	777	1100		350	650	
		800	815	1066		375	700	
		850	884	962		400	750	
		900	923	936		425	800	
		950	977	882		450	850	
		1000	1015	858		475	900	
		1050	1084	792		500	950	
		1100	1123	772		525	1000	
1150	1176	736	550	1050				
1200	1215	720	575	1100				

Tab. 20

H
R

> LTH30 S

... S version with reinforced and dampened end stops made of stainless steel

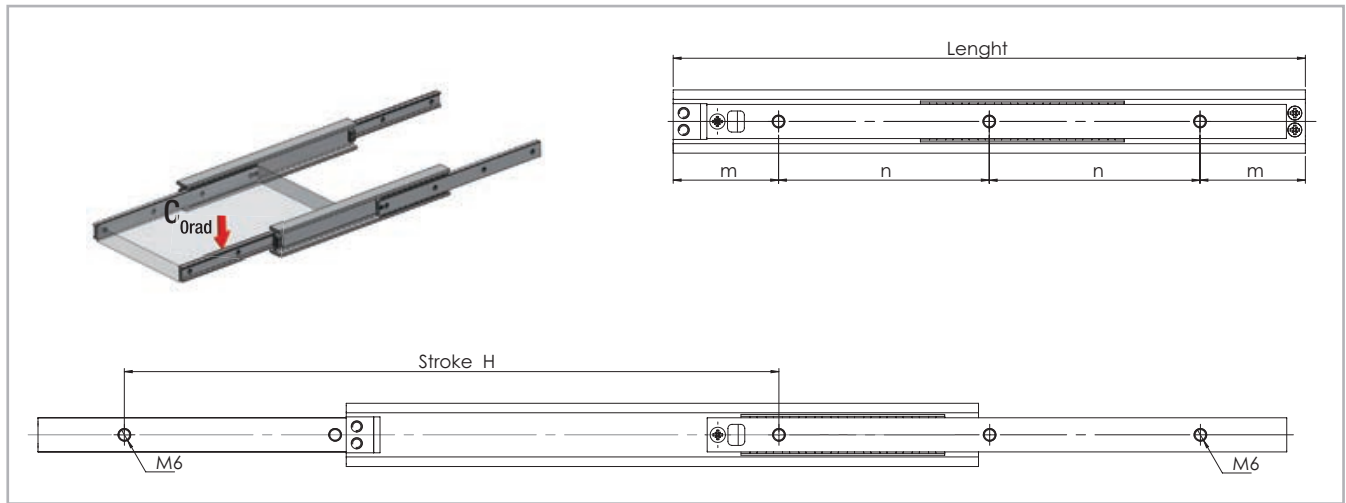

Fig. 44

Type	Size	Length L [mm]	Stroke H [mm]	Load capacity per pair		m [mm]	n [mm]	Number of holes
				C_{0rad} [N]	C_{0ax} [N]			
LTH...S	30	300	310	816	on request	50	100	3
		350	364	880		75		
		400	402	994		50		4
		450	472	1032		75		
		500	510	1330		50		5
		550	564	1498		75		
		600	618	1392		50		6
		650	671	1276		75		
		700	725	1178		50		7
		750	764	1138		75		
		800	817	1060		50		8
		850	871	992		75		
		900	925	932		50		9
		950	979	878		75		
		1000	1017	856		50		10
		1050	1071	810		75		
1100	1109	790	50	11				
1150	1179	732	75					
1200	1217	718	50	12				

Tab. 21

> LTH45 RF

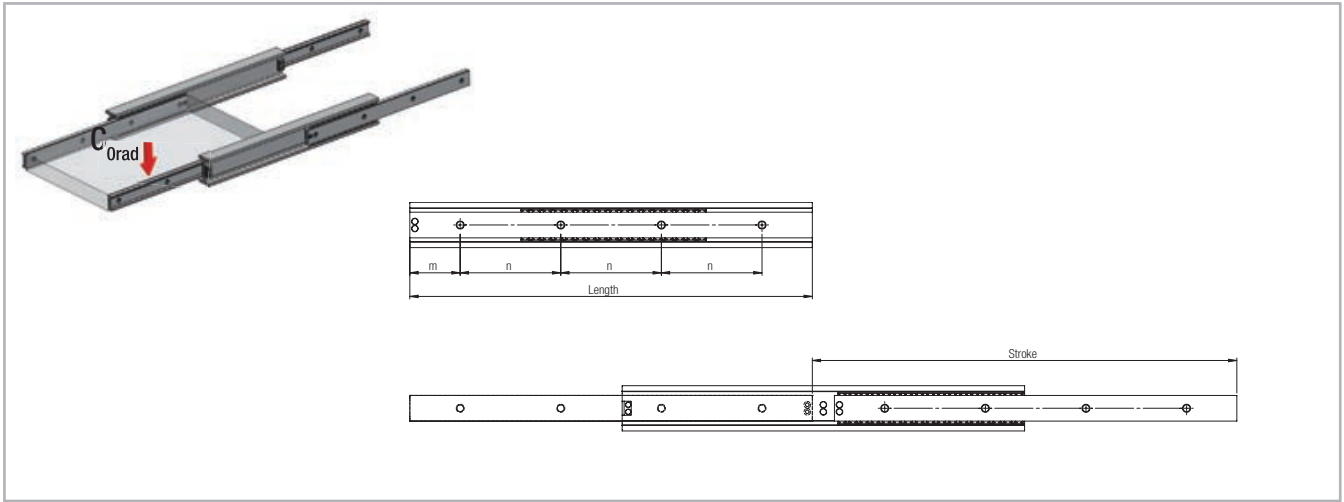

Fig. 45

Type	Size	Length L [mm]	Stroke H [mm]	Load capacity per pair		m [mm]	n [mm]	Number of holes
				C_{Orad} [N]	C_{Oax} [N]			
LTH	45	250	276	2610	on request	25	100	3
		300	310	2824		50		
		350	388	2820		25		4
		400	422	2842		50		
		450	478	2864		25		5
		500	512	2900		50		
		550	590	2764		25		6
		600	624	3032		50		
		650	680	3252		25		7
		700	714	3346		50		
		750	770	3084		25		8
		800	826	2860		50		
		850	882	2666		25		9
		900	916	2614		50		
		950	972	2450		25		10
		1000	1028	2306		50		
		1050	1084	2178		25		11
		1100	1118	2144		50		
		1150	1174	2034		25		12
		1200	1230	1934		50		
1250	1286	1842	25	13				
1300	1320	1818	50					
1350	1376	1738	25	14				
1400	1410	1716	50					
1450	1488	1596	25	15				
1500	1522	1578	50					

Tab. 22

> LTH45 KF

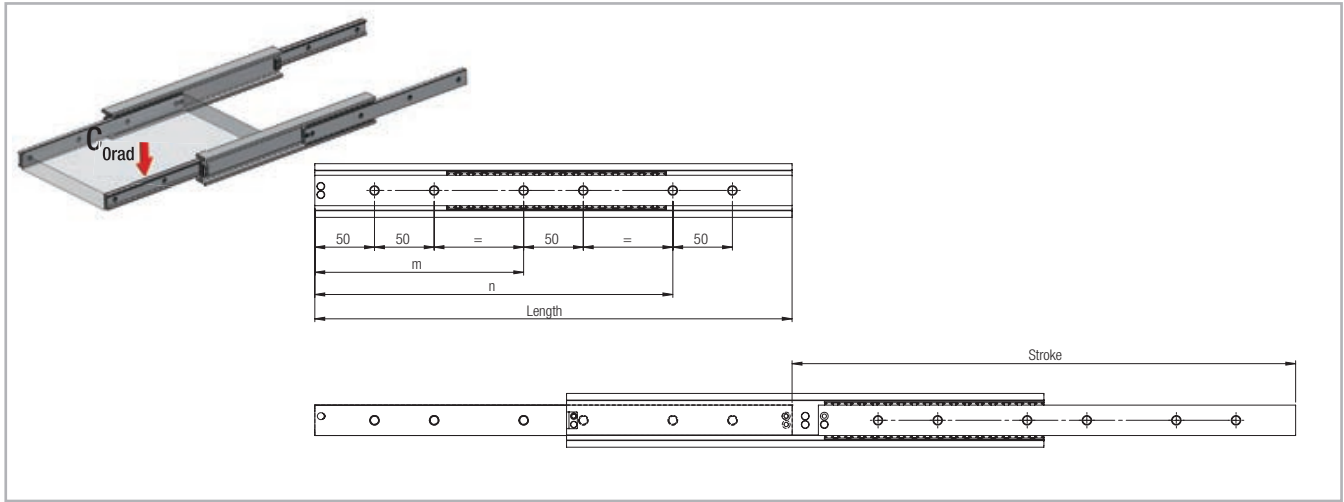

Fig. 46

Type	Size	Length L [mm]	Stroke H [mm]	Load capacity per pair		m [mm]	n [mm]	Number of holes
				C_{Orad} [N]	C_{Oax} [N]			
LTH	45	250	276	2610	on request	-	150	4
		300	310	2824			200	
		350	388	2820			250	
		400	422	2842			175	
		450	478	2864		200	350	6
		500	512	2900		225	400	
		550	590	2764		250	450	
		600	624	3032		275	500	
		650	680	3252		300	550	
		700	714	3346		325	600	
		750	770	3084		350	650	
		800	826	2860		375	700	
		850	882	2666		400	750	
		900	916	2614		425	800	
		950	972	2450		450	850	
		1000	1028	2306		475	900	
		1050	1084	2178		500	950	
		1100	1118	2144		525	1000	
		1150	1174	2034		550	1050	
		1200	1230	1934		575	1100	
1250	1286	1842	600	1150				
1300	1320	1818	625	1200				
1350	1376	1738	650	1250				
1400	1410	1716	675	1300				
1450	1488	1596	700	1350				
1500	1522	1578	725	1400				

> LTH45 S

... S version with reinforced and dampened end stops made of stainless steel

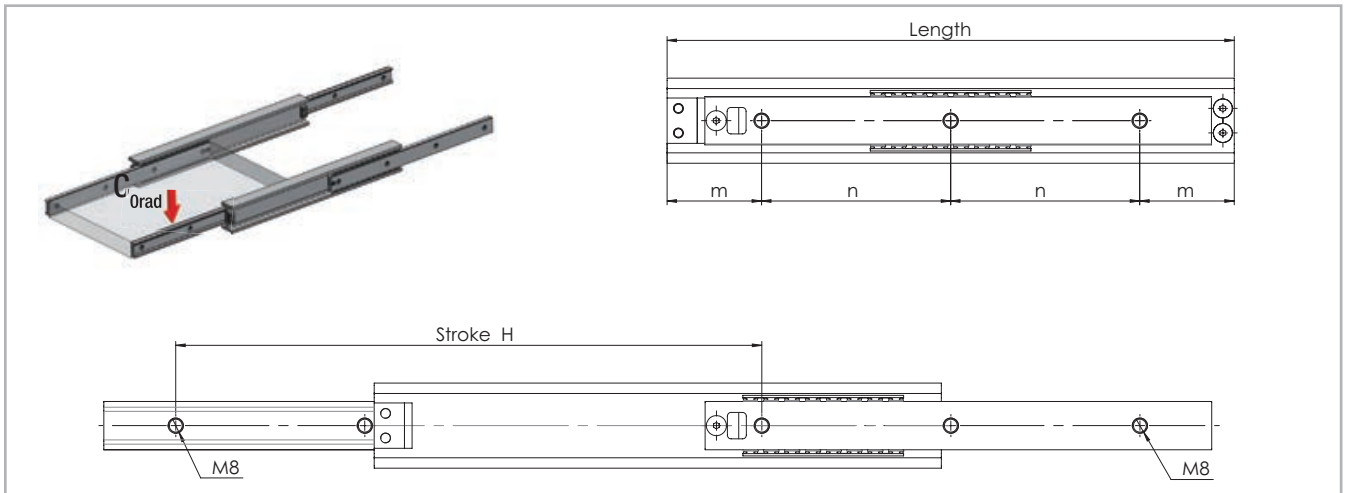
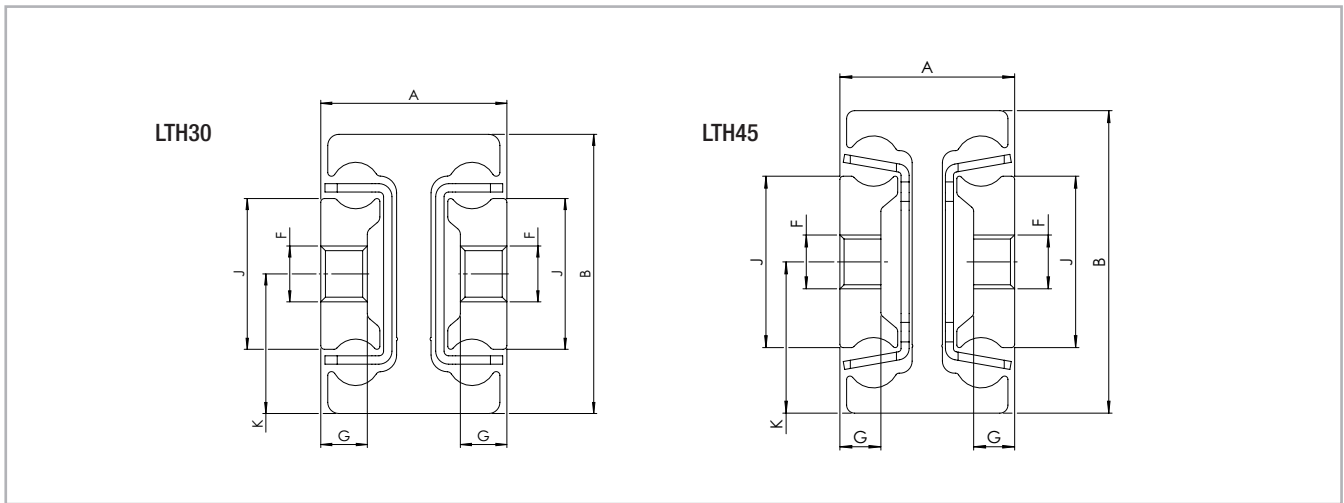

Fig. 47

Type	Size	Length L [mm]	Stroke H [mm]	Load capacity per pair		m [mm]	n [mm]	Number of holes
				C _{Orad} [N]	C _{Oax} [N]			
LTH...S	45	300	310	1316	on request	50	100	3
		350	366	1832		75		4
		400	422	1666		50		5
		450	456	2154		75		6
		500	512	1972		50		7
		550	568	2200		75		8
		600	624	2204		50		9
		650	680	2426		75		10
		700	714	2942		50		11
		750	770	3084		75		12
		800	826	2860		50		13
		850	882	2666		75		14
		900	916	2614		50		15
		950	972	2450		75		
		1000	1028	2306		50		
		1050	1084	2178		75		
		1100	1118	2144		50		
		1150	1174	2034		75		
		1200	1230	1934		50		
		1250	1286	1842		75		
1300	1320	1818	50					
1350	1376	1738	75					
1400	1410	1716	50					
1450	1488	1596	75					
1500	1522	1578	50					

Tab. 24

> LTH



All dimensions are indicated in mm

Fig. 48

Type	Size	A	B	J	G	K	F	Weight per single guide [kg/m]
LTH	30	20	30	16.2	5.0	15.0	M6	3.5
	45	26	45	25.5	6.1	22.5	M8	6.0

Tab. 25

> LTH Special strokes

Special strokes are defined as deviations from standard stroke.

They are each available as multiples of the values in tab. 26.

These values are dependent on the spacing of the ballcage.

Type	Size	Stroke modification [mm]
LTH	30	15,4
	45	22

Tab. 26

Each stroke modification influences the load capacities stated in the catalogue. For more information please contact Rollon technical support.

> HGT060, HGT080, HGT100, HGT120, HGT150, HGT200, HGT240

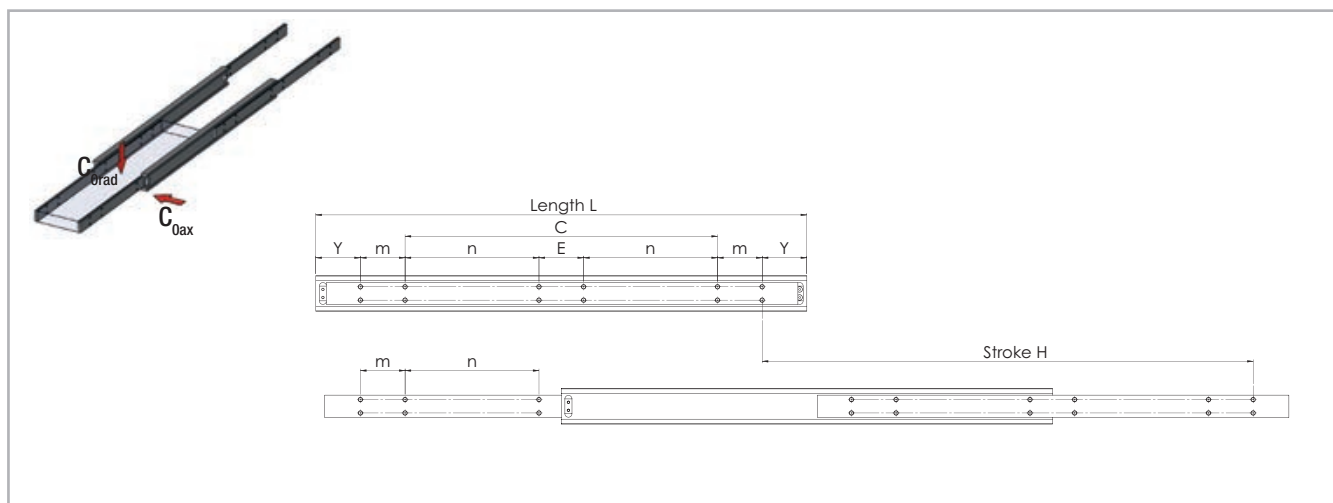

All dimensions are indicated in mm

Fig. 49

Type	Size	Length L [mm]	Stroke H [mm]	Load capacity per pair		Y	m	n	E	C	Number of holes					
				C _{Orad} [N]	C _{Oax} [N]											
HGT	60	400	400	5250	on request	50	50	-	-	200	8					
		450	450	5350						250						
		500	500	5400						300						
		550	550	5500						150	50	-	-			
		600	600	5400						175						
		650	650	5350						200						
		700	700	5250						225						
		750	750	5100						250						
		800	800	4900						275						
		850	850	4700						300						
		900	900	4500						325				50	-	12
		950	950	4300						350						
		1000	1000	4050						375						
		1100	1100	3700						425						
		1200	1200	3300						475						
		1300	1300	2900						525						
1400	1400	2500	575													
1500	1500	2100	625													

The load capacity for aluminum is 40% and for stainless steel 60% of the stated values, if available in this material variant (see Technical features overview).

Tab. 27

4 Load capacities and dimensions

Type	Size	Length	Stroke	Load capacity per pair		Y	m	n	E	C	Number of holes	
				C _{Grad} [N]	C _{Oax} [N]							
HGT	80	500	500	9000	on request	100	100			100	8	
		550	550	9250						150		
		600	600	9350						200		
		650	650	9200						250		
		700	700	9050						300		
		750	750	8800						350		
		800	800	8600						400		
		850	850	8350						450		
		900	900	8100						500		
		950	950	7850						550		
		1000	1000	7550				600				
		1100	1100	7150				300	100	-		12
		1200	1200	6700				350				
		1300	1300	6200				400				
		1400	1400	5700				450				
		1500	1500	5200				500				
		1600	1600	4600				550				
		1700	1700	4100				600				
		1800	1800	3600				650				
		1900	1900	3000				700				
2000	2000	2500	750									

The load capacity for aluminum is 40 % and for stainless steel 60 % of the stated values, if available in this material variant (see Technical features overview).

Tab. 28

Type	Size	Length		Stroke		Load capacity per pair		Y	m	n	E	C	Number of holes		
		L [mm]	H [mm]	C _{Orad} [N]	C _{Oax} [N]										
HGT	100	700	700	11000	on request	100	200	-	-	-	100	8			
		750	750	10750							150				
		800	800	10500							200				
		850	850	10250							250				
		900	900	10000							300				
		950	950	9750							350				
		1000	1000	9500							400				
		1100	1100	9000							150		200	-	12
		1200	1200	8500							200				
		1300	1300	7900							250				
	1400	1400	7300	300											
	1500	1500	6700	350											
	1600	1600	6100	400											
	1700	1700	5450	450											
	1800	1800	4800	500											
	1900	1900	4100	550											
	2000	2000	3400	600											

The load capacity for aluminum is 40% and for stainless steel 60% of the stated values, if available in this material variant (see Technical features overview).

Tab. 29

Other sizes and versions are available on request

Type	Size	Length		Load capacity per pair	
		L [mm]	C _{Orad} [N]	C _{Oax} [N]	
HGT	120	700	11500	on request	
		⋮	⋮		
		2000	4700		
	150	700	13900		
		⋮	⋮		
		2000	7000		
	200	700	15000		
		⋮	⋮		
		2300	6700		
	240	700	17500		
		⋮	⋮		
		2000	12500		

The load capacity for aluminum is 40% and for stainless steel 60% of the stated values, if available in this material variant (see Technical features overview).

Tab. 30

> HGT

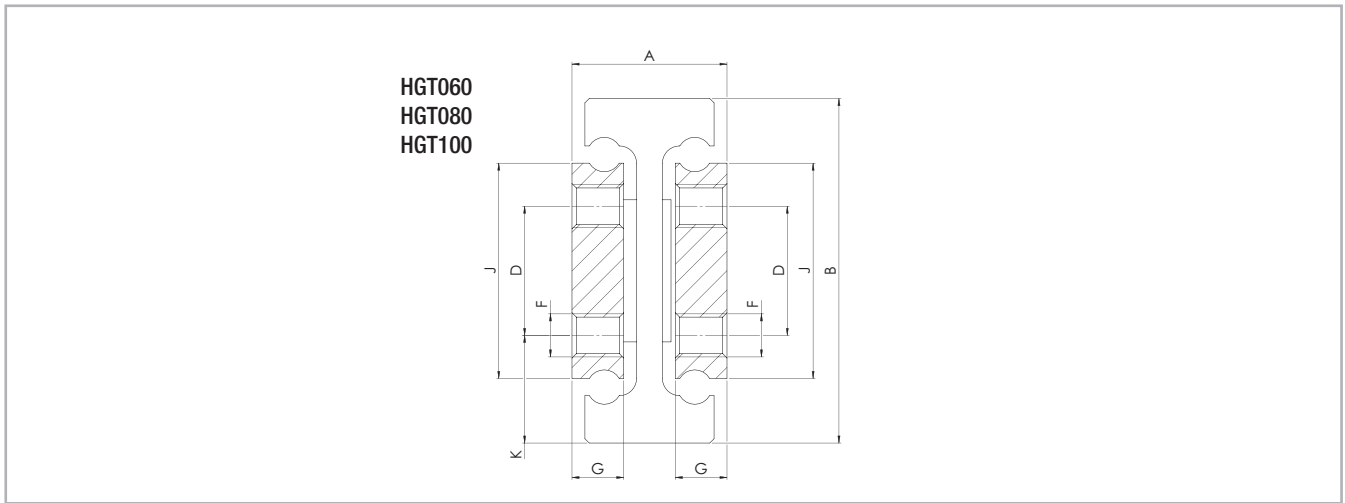

All dimensions are indicated in mm

Fig. 50

Type	Size	A	B	J	G	K	D	F	Weight per single guide [kg/m]
HGT	60	32	60	40	10	19	22	M6	11.70
	80	36	80	50	12	25	30	M10	17.50
	100	44	100	70	15	27.5	45		27.60

Tab. 31

> LTF44

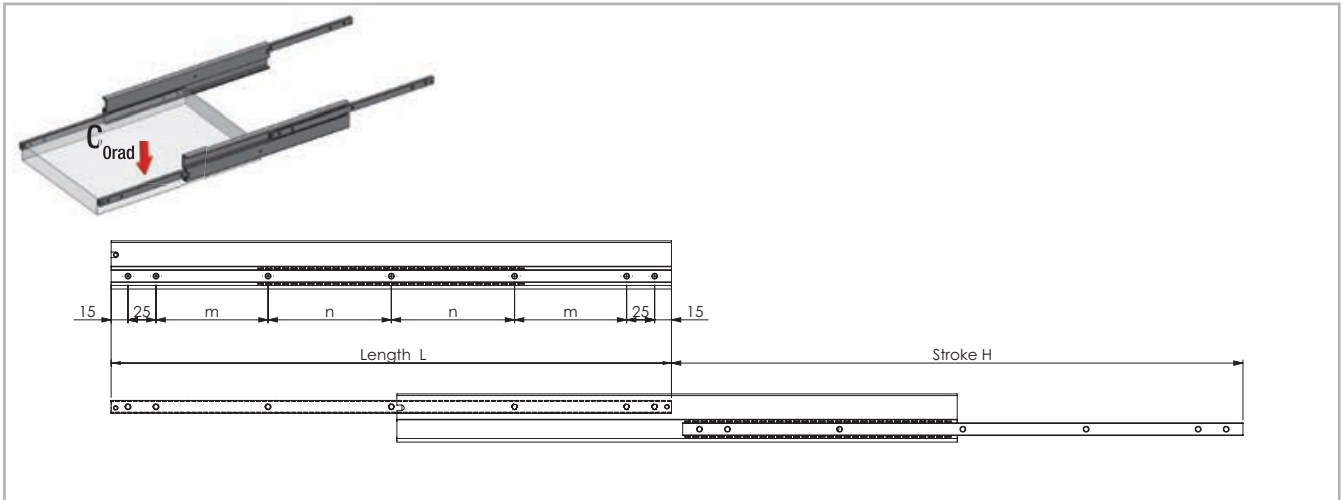

All dimensions are indicated in mm

Fig. 51

Type	Size	Length	Stroke	Load capacity per pair C_{Orad} [N]	Fixed and moving rails		Number of holes
		L [mm]	H [mm]		m [mm]	n [mm]	
LTF	44	200	210	228	60	-	5
		225	235	260	72.5		
		250	260	288	85		
		275	285	324	97.5		
		300	310	360	110		
		325	335	392	122.5		
		350	360	420	135		
		375	385	452	147.5		
		400	410	492	160		
		425	435	524	172.5		
	450	460	552	185	100	7	
	500	510	624	110			
	550	560	684	135			
	600	610	768	160			
	650	660	816	185			
	700	710	888	160			
	750	760	948	185			
	800	810	1020	210			
	850	860	1080	235			
	900	910	1152	260			
950	960	1224	285				
1000	1010	1296	310				

Tab. 32

> LTF44

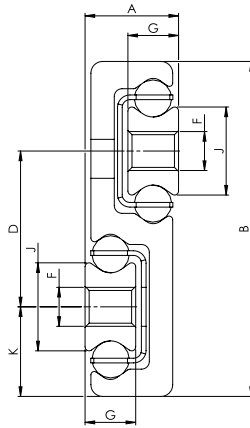

All dimensions are indicated in mm

Fig. 52

Type	Size	A	B	J	G	K	D	F	Weight per single guide [kg/m]
LTF44	44	12	43	11.3	6.5	11.5	20	M5	2.7

Tab. 33

> HGS060

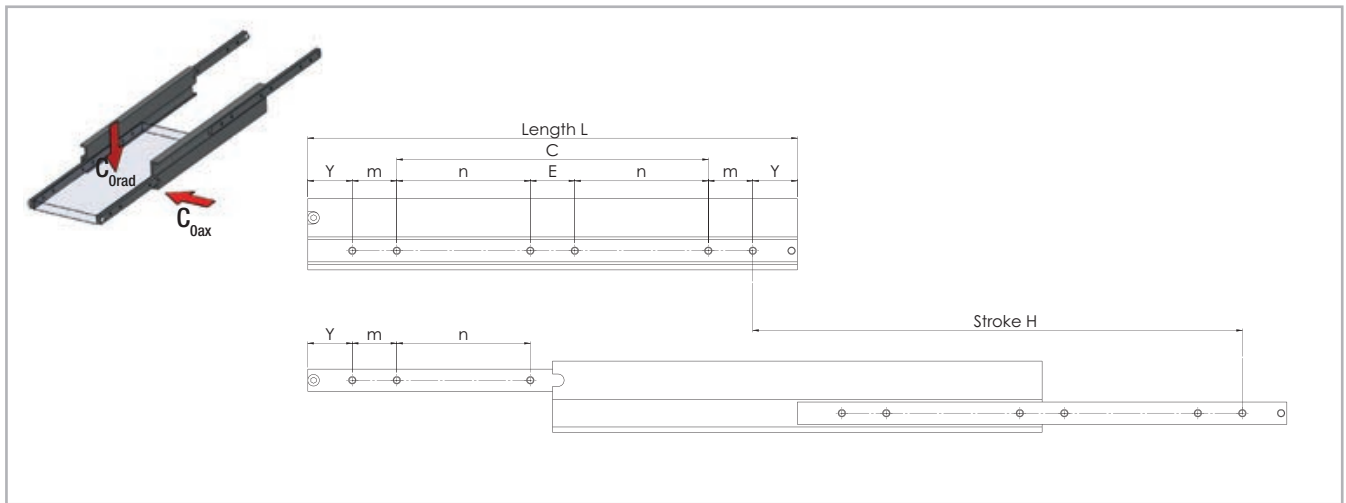

All dimensions are indicated in mm

Fig. 53

Type	Size	Length	Stroke	Load capacity per pair C_{Orad} [N]	Y	m	n	E	C	Number of holes	
		L [mm]	H [mm]								
HGS	60	250	250	1000	50	50				50	4
		300	300	1250						100	
		350	350	1350						150	
		400	400	1400						200	
		450	450	1400						250	
		500	500	1400						300	
		550	550	1350			150	50	-	-	6
		600	600	1300			175				
		650	650	1250			200				
		700	700	1200			225				
		750	750	1150			250				
		800	800	1050			275				
		850	850	950			300				
		900	900	850			325				
		950	950	750			350				
		1000	1000	650			375				

The load capacity for aluminum is 40% and for stainless steel 60% of the stated values, if available in this material variant (see Technical features overview).

Tab. 34

> HGS

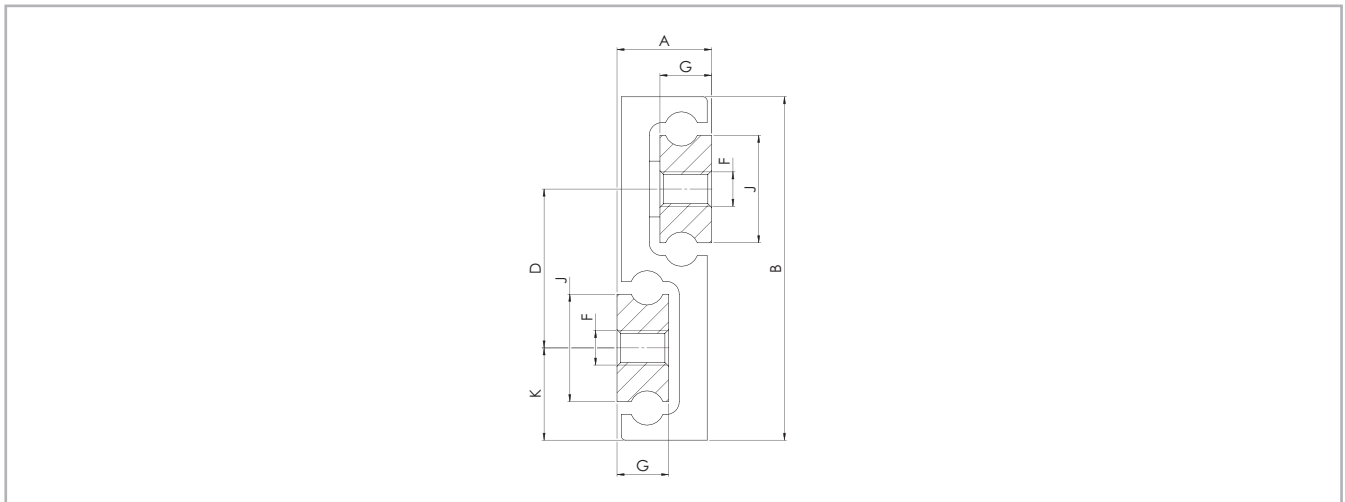

All dimensions are indicated in mm

Fig. 54

Type	Size	A	B	J	G	K	D	F	Weight per single guide [kg/m]
HGS	60	17	60	16	10	16	28	M6	6.00

Tab. 35

Accessories

Available options (depending on telescope version)

> Locking

Locking mechanisms make it possible to lock the Hegra rails in the end position. This prevents inadvertent extension or retraction of the rail in any case. Locking mechanisms can be implemented as locking bolts or bars. This ensures personal safety and protection of materials, especially in moving installations, as in vehicles. For models HGT with locking please observe right or left side use.



Fig. 55



Fig. 56

> Driving disc

In the full extension rails with dual stroke the intermediate element does not follow a particular order. The exact position of the element is therefore defined only in fully extended condition. The optional driving disc defines the movement of the intermediate element. This prevents unwanted protrusion of the element. An example for use of the driving disc is in warehouse rails, which are extended in both directions.

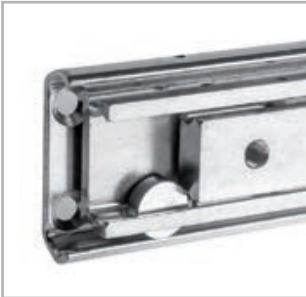

Fig. 57



Fig. 58

> Damping

Hegra telescoping rails can be equipped with damped end stops in closed position. Plastic or elastomer damping elements provide for quieter operation, a softer end stop when pushing in the rail and higher resistance at the end of the stroke.

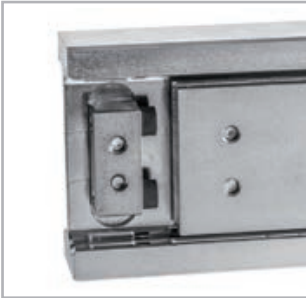

Fig. 59

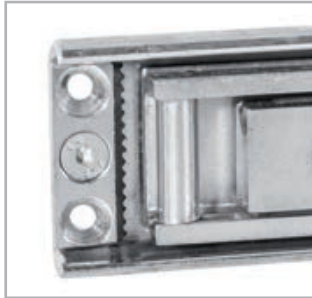

Fig. 60

> Snap

Hegra Rail telescopic guides can be partial with a snap through a ball thrust piece. Thus, an unintended process of the telescope system is avoided.

Note: Not all accessories (interlocks, damping, Drive disk, snap) can be combined with each other and available. (see Technical features overview) Please contact our technical service.

Technical information



> Selecting a suitable telescoping rail

To find a telescoping rail that meets your requirements, the following factors must be considered.

- Desired load capacity
- Available sizes (height, width and rail length)
- Required extension type (partial, full extension, etc.)
- Length of travel
- Desired material and surface

> Mounting tolerances

Installation

length (mm)	$\geq 150 < 420$	$\geq 420 < 1050$	$\geq 1050 < 2840$
Tolerance (mm)	± 0.5	± 0.8	± 1.2

At the installation, width tolerances of ± 0.5 mm for compensating are to be considered. For all other dimensions, the tolerances according to DIN ISO 2768-1 (m) apply.

> Life cycle

The life cycle describes the time span from installation to failure of the telescoping rail, due to wear.

The life cycle is affected by the following factors.

- Load
- Assembly precision
- Parallelism when installed in pairs
- Rigidity of the connection construction
- Jolts and vibrations
- Operating temperature
- Lubrication (in accordance with maintenance intervals)

> Load capacity

The specified maximum load capacity always refers to one pair of vertically installed telescoping rails. To achieve this capacity, the following requirements must be fulfilled.

- An absolutely rigid connection construction
- Even distribution of the load over the entire length of the moving rail element
- Mounting of the telescoping rails on a flat and rigid surface using all provided mounting holes
- Please be sure to use the correct screw length to prevent damage to the ball cage: shank length of screw < thickness of the moving element
- Vertical installation of telescoping rails

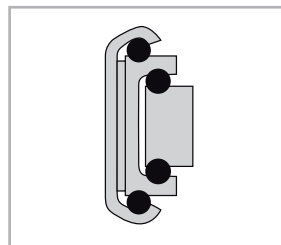

Vertical installation

Fig. 61

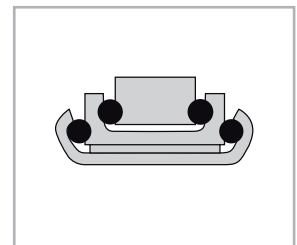

Level installation

Fig. 62

If optimal implementation of all of these requirements is not possible, we will be glad to assist you in calculating the actual load capacity.

In case of a level installation of the telescoping rails (axial load direction), only a reduced value of the radial load capacity is possible.

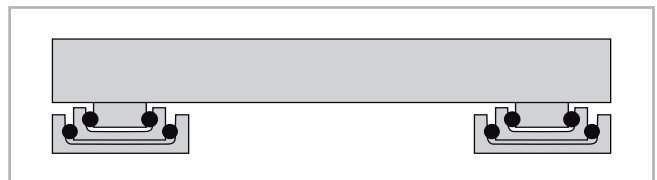

Fig. 63

> Deflection

If the telescopic guides of the HGT series are assembled in pairs and the requirements under "Load capacity" are taken into account, the maximum deflection of steel rails under full load is 1 % of the extended length (stroke). Example: 500 mm length of travel -> max. 5 mm deflection under full load.

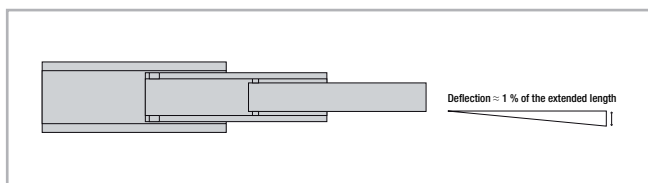

Fig. 64

Note: All other deflection of the Hegra Rail product family on request

> Operating temperature

The telescopic rails can be used at ambient temperatures from -20 °C to +170 °C (-4 °F to +338 °F). At lower temperatures down to -30 °C (-22 °F) or higher temperatures up to +250 °C (+482 °F), please contact our application engineers. These ranges always require the use of a special lubricant.

The operating temperature is -20 °C to +50 °C (-4 °F to +122 °F) when damping is used.

> Corrosion protection

As standard features, all series are zinc electroplated, thick-film passivated and Reach/RoHS compliant. For higher corrosion protection we offer zinc nickel plating with stainless steel balls. Overview of available coatings:

Coating type thickness 12-15µm	Salt-spray test DIN EN ISO 9227	Reach/ RoHS
Thick-film passivated	ca. 400 hours	yes
Zinc nickel	more than 700 h	yes

Tab. 36

> Clearance and preload

Hegra Rail guides are mounted as standard with no play. For more information, please contact Rollon technical support.

Preload classes		
Increased clearance	No clearance	Increased preload
G ₁	Standard	K ₁

Tab. 37

* for higher preload, contact Rollon technical support.

> Ball cage displacement

The stroke movement of a telescoping rail is achieved by the ball cages, among other elements. You should ensure that the telescoping rail is always fully extended and retracted, since otherwise the ball cages can become displaced. Ball cage displacement occurs as a result of slippage and means that you can achieve the required extension length and the desired closed condition of the telescoping rail only with increased application of force.

Automated systems must have sufficient reserve driving force or an additional maximum stroke must be planned for in order to prevent displacement.

On request we also implement custom design solutions. Feel free to contact us.

> Moving force

The moving force is subject to production-related tolerances and is also defined by the load and the deflection of a telescoping rail. Taking into account the load and deflection of a telescoping rail, the closing force is higher than the opening force, since deflection occurs under load and closing takes place by pushing against a slanted plane.

> Lubrication

Alternative lubricants, for example for the food industry, or alternate temperature ranges are available on request. Our aluminium or stainless steel telescoping rails are generally delivered without grease.

> Maintenance intervals

A visual inspection should be conducted occasionally; foreign particles should be removed and “dry” guide rails should be lightly lubricated with roller bearing grease. This prevents friction, protects the components and prolongs the life of the system. The lubrication intervals are variable and should be determined based on the respective operating conditions such as load, ambient conditions, travel speed, temperature, pollution, etc.

> Mounting instructions

- Please use all mounting holes, in addition to screws of the correct length.
- A stable base is necessary for mounting the telescoping rails.
- In the connection construction, be aware that we have switched to counterbores according to DIN 74 Form F and due to the material thickness of our profiles, the head of the countersunk screw protrudes somewhat from the profile, so that the mating piece must have a corresponding counterbore.

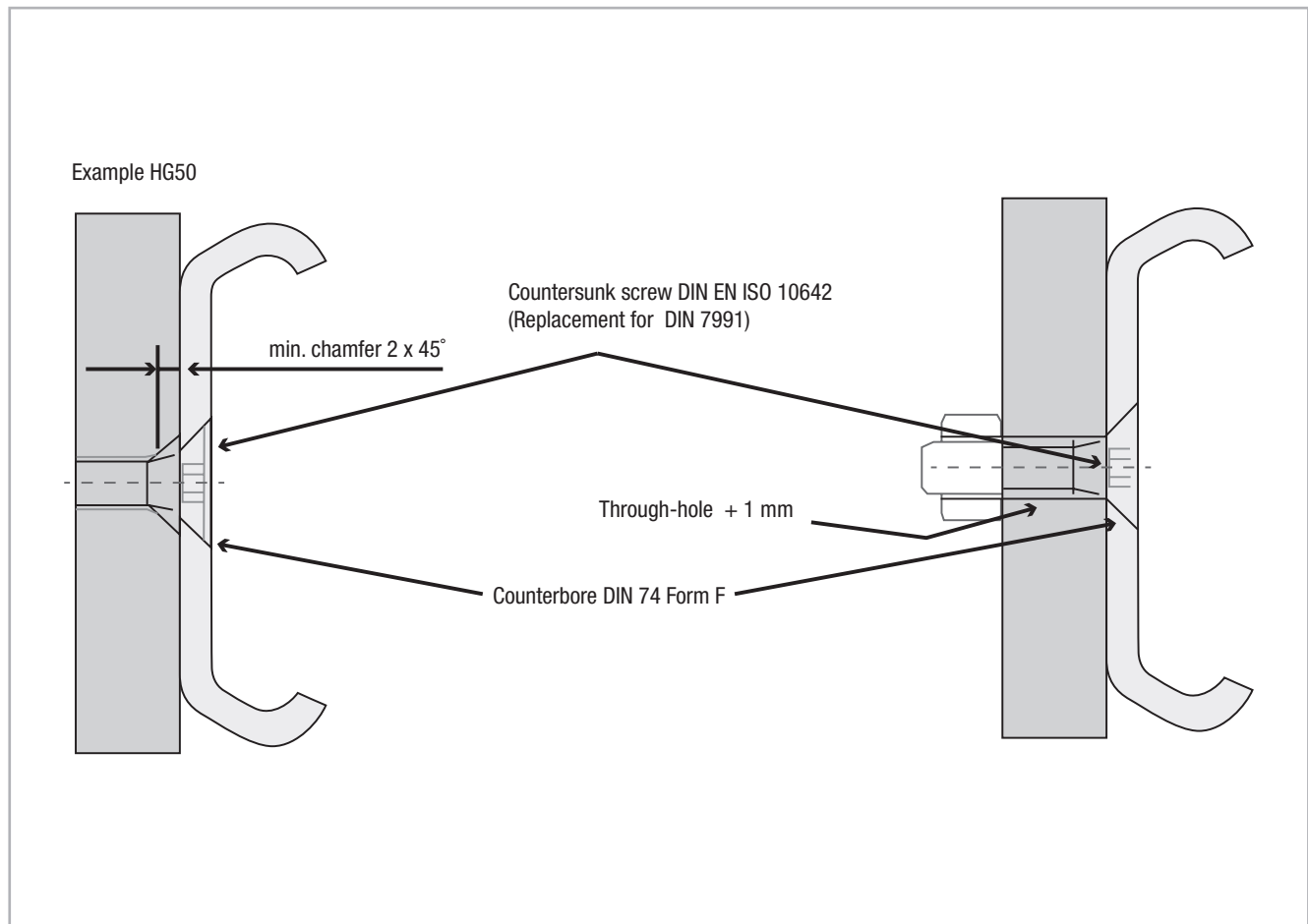

Fig. 65

Ordering key

> Hegra Rail

HGTX080	0500	0600	EG	VO	DG	B	Z	R	
									right or left version
									alternate coating
									stroke in both directions
									damping
									locking
									snap
									alternate stroke
									closed length
type with material and size									

Note on ordering: The size is always indicated as 3 digits, the length of the rail and the stroke are always 4 digits with the 0 prefixes.

Not all fields must be filled out. If they are not used, they remain empty.

Ordering example: HGTX080-0500-0600-EG-VO-DG-B-Z-R

Type	
HTT	partial extension machined/drawn profile
HVC	full extension single c-profile
H1C	over extension 150 % single c-profile
H1T	over extension 150 % machined/drawn profile
H2H	over extension 200 % machined/drawn profile
LTH	heavy duty slide
HGT	heavy duty slide
LTF	s-profile
HGS	s-profile

Material	
	steel
A	aluminum
X*	stainless steel

* Different stainless steels, such as the “electropolishing” option, are available, please contact our technical service.

*To process your order for stainless steel telescopic systems we need the material number you prefer. Please consider: Our standard material for rails and sliders in V2A is 1.4301 (AISI304), in V4A it is 1.4571 (AISI316Ti) and that the material of our stainless balls is 1.4034 (AISI420)

Accessory	
	no accessory
EO	snap on opened position
EG	snap on closed position
EB	snap on closed an opened position
VO	locking opened position
VG	locking closed position
VB	locking on closed an opened position
DG	damping closed position
B	stroke on closed an opened position
BM	stroke on closed an opened position with synchronization

Coating	
	thick-film passivation
Z	zinc nickel
N	nickel
E	anodizing colorless

Layout	
L	left version
R	right version

Special/Configuration	
S01	special (according to drawing)
C01	configuration (special stroke, stainless steel balls, special grease)

ROLLON[®]
BY TIMKEN

Telerace



Product explanation



> Telerace roller telescopic slides



Fig. 1

The Telerace family is composed of telescopic slides made of sheet steel of particular precision finish, fully hardened with patented Rollon Nox process. This treatment assures long lifetime without wear and a good corrosion resistance. Telerace slides are suitable for harsh ambient environment, since the rollers are much less sensitive than balls. TLR and TLQ series represent the high performance telescopic slides. TLN and TQN offer many of the technological advantages with a more simplified construction, TLAX and TQAX are completely made of stainless steel. The listed load capacities are per pair of slides, with the load centred. In case the load is not centred, the load capacity is reduced.

TLR-TLQ series

TLR and TLQ series represent the high performance telescopic slides. Top features like hardened and honed raceways, strong double row ball bearings, wipers with incorporated pre-oiled felt and robust rubber stoppers make them ideal for all kinds of industrial high frequency applications, including variable and vertical stroke.

TLN-TQN series

The telescopic slides TLN and TQN offer many of the technological advantages from the top-range slides, like hardened raceways and robust rubber stoppers, but with a more simplified construction to offer a range of cost-effective telescopic slides with good load capacities for industrial applications. All models are available in K-version, for higher corrosion resistance, and with other optional surfaces treatments.

TLAX-TQAX series

TLR-2

The INOX slides TLAX and TQAX are available in X-version with rails and intermediate S-element electro-polished for very high corrosion resistance, making them ideal for most critical outdoor applications.

Industrial automation

Telerace slides are especially recommended for high frequency applications, where long service requirements and low maintenance are necessary. Roller telescopic slides are superior for motorized automation with or without variable stroke-cycles, to eliminate the typical problem of ball cage creeping that subsequently can cause serious motor jamming-problems, when increased motor power is instantly required to reposition the ball cage. The materials and surface treatments assure high corrosion resistance, and with the additional treatments Telerace slides become suitable for outdoor applications or very humid ambient.

TLR

TLR series provides excellent smooth and play-free running performance, along with high load capacities and low flexion. Good cleaning, proper lubrication and reduced maintenance thanks to pre-oiled felts on the strong wipers. When TLR series slides are used in pairs, they offer the possibility to absorb minor misalignment errors.

TLQ

TLQ series are very compact slides with a square cross section that offer good load capacities, both axial and radial, and are particularly suitable for vertical applications, thanks to their compactness and light weight. TLQ series is composed of two single rails fixed together to form a rigid H-profile as an intermediate element. As TLR series, TLQ series features double row bearings. Possible customised stroke.

TLN

TLN series features an innovative constructive design that combines cost-effective rails with advanced technology. The hardened rails assembled to a rigid intermediate S-shaped element provide excellent smooth and play-free running performance, along with high load capacities and low flexion. Also available the HP version with additional rollers to increase the load capacity, about 40-50% more, with no change in external dimensions.

TQN

TQN series are very compact slides with a square cross section that offer good load capacities, both axial and radial, and are particularly suitable for vertical applications, thanks to their compactness and light weight. TQN series is composed of two single rails fixed together to form a rigid H-profile as an intermediate element. As TLN series, TQN series features single row bearings. Possible customised stroke.

TLAX

TLAX series are made of AISI 304 rails and AISI 404 hardened steel rollers, with 2RS seals and lubricated for life with grease for longevity and low temperature applications. TLAX is ideal for medical, pharmaceutical, chemical, medical industries or maritime ambient. For very severe environmental conditions, TLAX can be supplied in X-version, which provides an improved corrosion resistance. Customized versions with longer extension, length and stroke are available upon request.

TQAX

TQAX series are very compact stainless-steel slides with a square cross section that offer good load capacities, both axial and radial, and are particularly suitable for vertical applications, thanks to their compactness and light weight. TQAX series is composed of two single rails fixed together to form a rigid H-profile as an intermediate element. Rails are in AISI 304 and single row bearings in hardened AISI 440 with 2RS seals and lifetime lubricated.



Fig. 2



Fig. 3



Fig. 4



Fig. 5



Fig. 6



Fig. 7

Overview product cross sections



> TLR-TLQ series

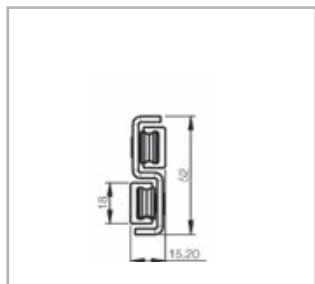

Fig. 8

TLRD18 - TLRS18

Load capacity p. TLR-8

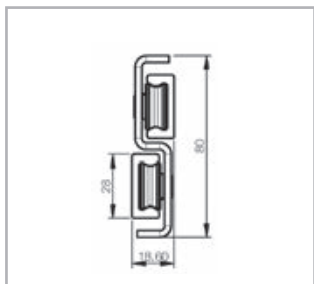

Fig. 9

TLRD28 - TLRS28

Load capacity p. TLR-9

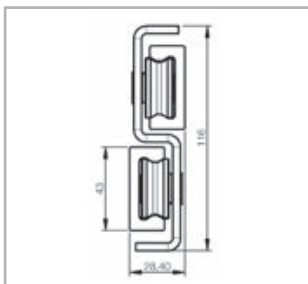

Fig. 10

TLRD43 - TLRS43

Load capacity p. TLR-9

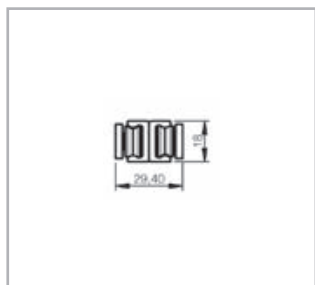

Fig. 11

TLQ18FF

Load capacity p. TLR-11

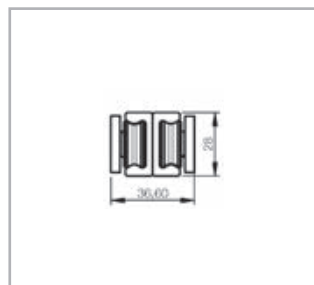

Fig. 12

TLQ28

Load capacity p. TLR-12

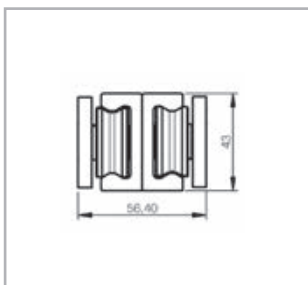

Fig. 13

TLQ43

Load capacity p. TLR-12

> TLN-TQN series

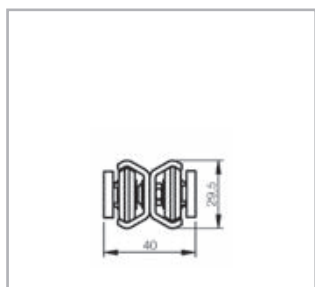

Fig. 14

TQN30

Load capacity p. TLR-16

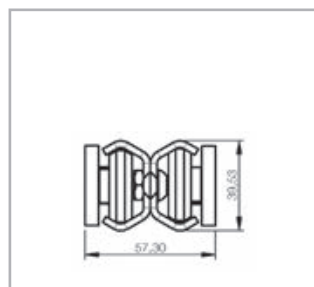

Fig. 15

TQN40

Load capacity p. TLR-17

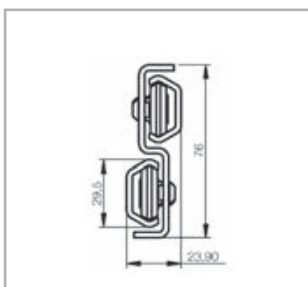

Fig. 16

TLND30 - TLNS30

Load capacity p. TLR-14

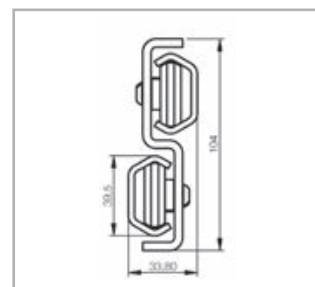

Fig. 17

TLND40 - TLNS40

Load capacity p. TLR-14

> TLAX-TQAX series

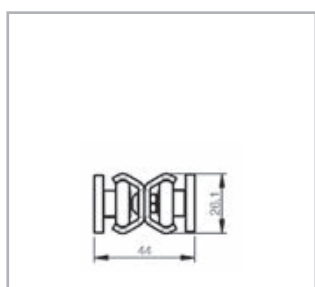

Fig. 18

TQAX26

Load capacity p. TLR-20

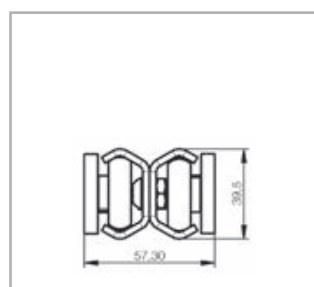

Fig. 19

TQAX40

Load capacity p. TLR-20

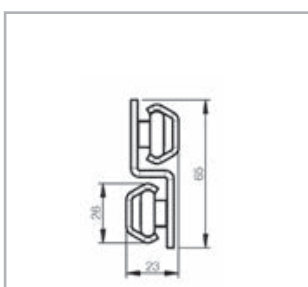

Fig. 20

TLAX26

Load capacity p. TLR-19

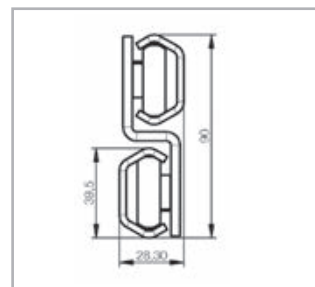

Fig. 21

TLAX40

Load capacity p. TLR-19

TLR-4

General characteristics



> TLR-TLQ series

Cold drawn steel rails with Patented ROLLON-NOX treatment for high depth nitride hardening and with black oxidation, assuring long lifetime without wear and a good corrosion resistance.

- **High hardness**
- **Durable for high load/frequency**
- **Long life**
- **Good corrosion resistance**
also on the raceways, tested for 120 hours in salt fog.

Strong double row ball-bearings, 2RS seals and lubricated for life.

- **setting for smooth play-free running.**

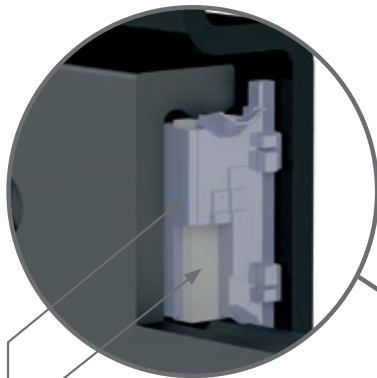

Wipers with incorporated pre-oiled felt for optimum long term raceway lubrication, assuring low maintenance

Internal strong wipers for good raceway cleaning

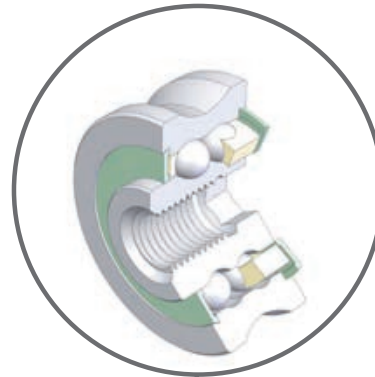

Robust rubber stoppers for smooth dragging of intermediate element

Silent and fast movement with no play

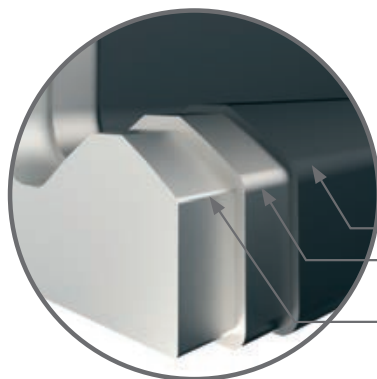

black oxidation with micro oil impregnation, ROLLON-NOX, anti-corrosion treatment

High depth nitriding technology ROLLON-NOX

High strength cold drawn steel alloy profile

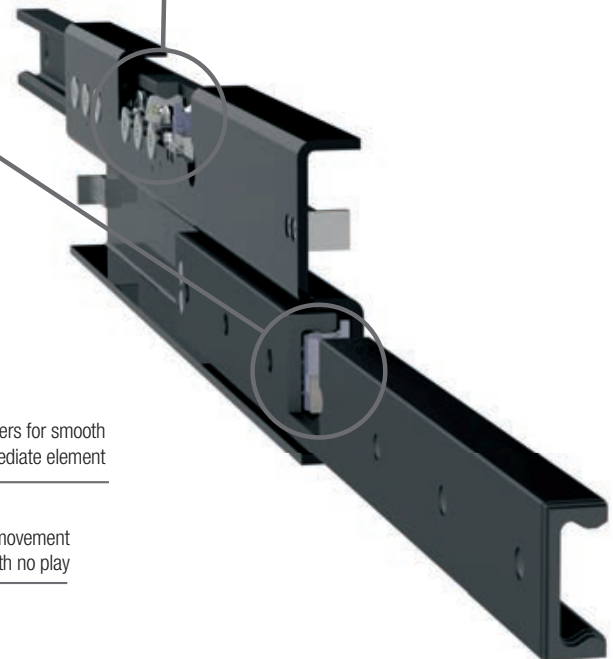

Fig. 22

TLR-5

> TLN-TQN series

Roll formed steel rails, nitride hardened and post black oxidation, patented ROLLON-NOX treatment, for efficient corrosion protection.

- **Hardened raceways**
- **Durable for high load/frequency**
- **Good lifetime**
- **Good corrosion resistance,** also on the raceways, tested for 120hours in salty fog.

Available also in stainless steel: TLAX,TQAX.

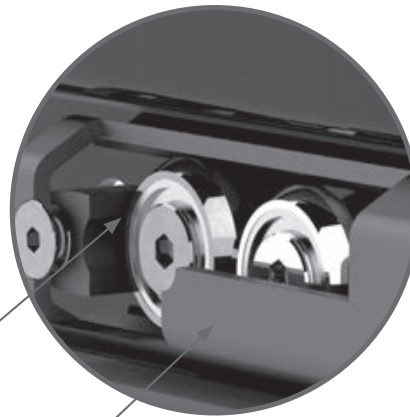

Robust rubber stoppers for smooth dragging of intermediate element

Silent and fast moment with no play

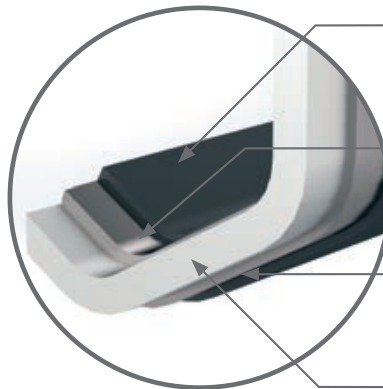

Anti-corrosion treatment: black oxidation with micro oil impregnation

Nitride hardening technology, ROLLON-NOX treatment

Optional surface coatings: ROLLON e-coating, ROLLON p-color and ROLLON p-polishing

High resistance roll formed steel profile

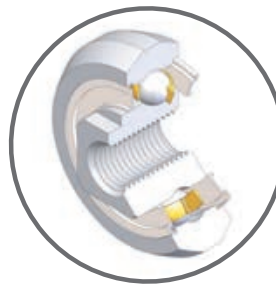

Single row ball-bearings, 2Z seals and lubricated for life.

- **Eccentric rollers for preload**
- **setting for smooth play-free running.**



Optional surface treatment

ROLLON e-coating: glossy black epoxy electro coating for high corrosion resistance, tested for 700 hours in salt fog.

ROLLON p-color: powder coating in RAL-colors for customized coloured rails with high corrosion resistance.

Fig. 23

Dimensions and load capacity ✓

> TLR

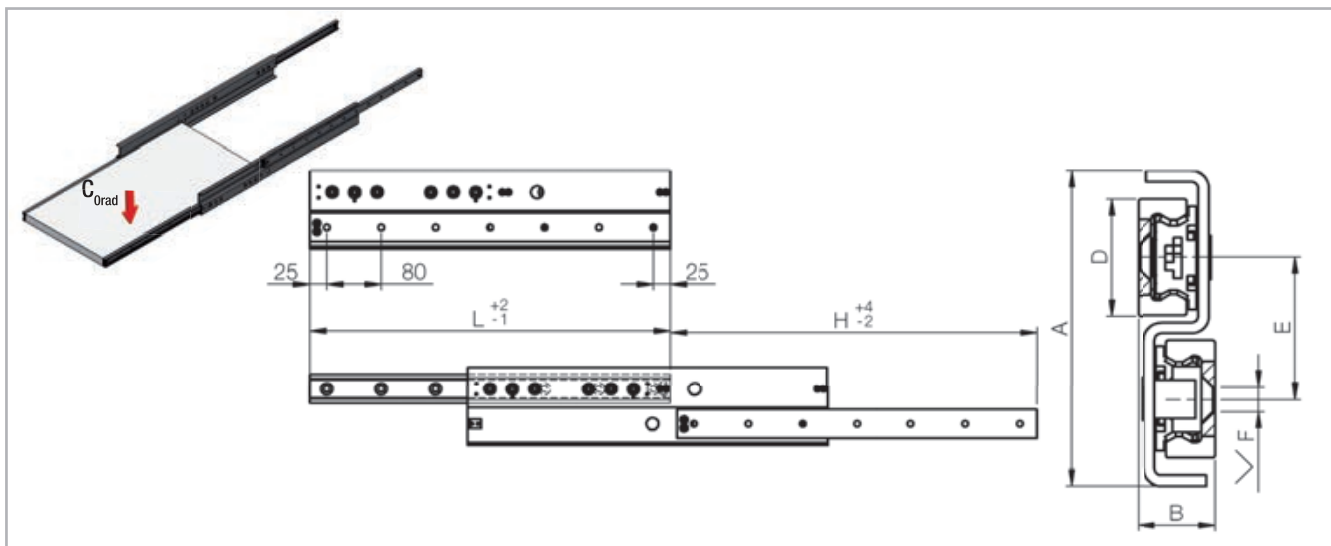

Fig. 24

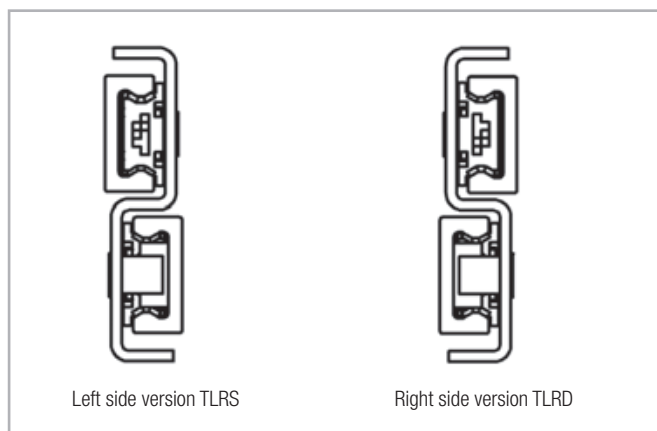

Fig. 25

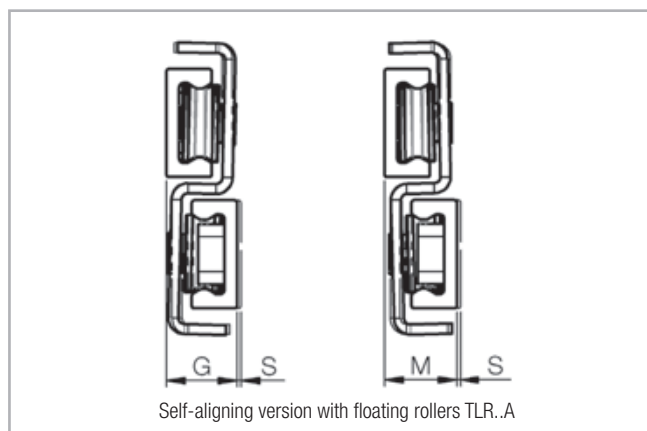

Fig. 26

Code	Size	A [mm]	B [mm]	D [mm]	E [mm]	F [mm]	G [mm]	M [mm]	S [mm]
TLR	18	52	15,2	18	25	Ø 4,5 for screw M4 DIN7991	14,7	15,7	1
	28	80	18,6	28	35	Ø 5,5 for screw M5 DIN7991	17,2	19	1,8
	43	116	28,4	43	52	Ø 8,5 for screw M8 DIN7991	26,8	30	3,2

Tab. 1

Self-aligning capability

When TLR slides are used in pairs, they offer the possibility to absorb minor structural errors or non-precise installation, which otherwise would much increase the required force for moving the mobile part, in both extending and closing direction. Such “binding-problems” for installation on non precise structures, common for ball-cage slides and can be eliminated/ much reduced with a pair of self-aligning TLR..A slides. A problem of heavy binding will consequently much reduce load capacity and expected life-time. The self-aligning capability is obtained by having a combination of floating and guiding rollers in the TLR..A. i.e. allowing for a minor rotation

of the rails whilst maintaining the preload in both upper and lower rails. The suffix A in TLR..A, indicates “Aligning”. To be noted that the rotation ex. of the TLR28A slide hereby changes the nominal value of 18,6mm to 17,2mm (S min) – 19,0mm (S max) while compensating dimensional errors on mobile structures or distance errors between the two lateral sides of fixed structures, for which the upper rails are fixed to. The TLR..A is in general always used as a pair with a standard TLR, to assure good lateral stability.

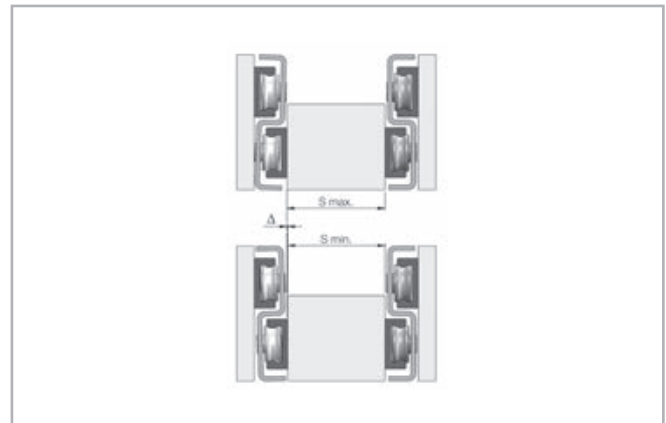

Fig. 27

Version	Characteristics
BASIC	Cold drawn steel rails with patented “ROLLON-NOX”; high depth nitride hardening and black oxidation treatment. The rails are cut to size after treatment, so the rail ends are protected by protective spray. The rollers are core hardened steel, while the intermediate steel S-element is protected with black epoxy electro coating - “ROLLON e-coating” .
Q	As a basic TLR product but with additional black “ROLLON e-coating” on the rails, for high corrosion resistance (min 700 hours resistance in salt fog) . The rail has no ROLLON e-coating on the raceway contact area with the rollers, as masked before the treatment. The raceways are anyhow with standard oxidation while the wipers with incorporated pre-oiled felt assure lubrication and corrosion protection of raceways.
K	As the version Q but with the rollers made in stainless steel AISI440C

Tab. 2

Code	Size	Length L [mm]	Stroke H [mm]	Dynamic coefficient C C [N]	Load capacity for a pair of rails $C_{o_{rad}}$ [N]	Weight [kg]
TLR	18	290	290	731	710	0,9
		370	370	969	940	1,2
		450	450	1115	1082	1,4
		530	530	1214	1178	1,6
		610	610	1286	1246	1,9
		690	690	1324	1284	2,1
		770	770	1344	1304	2,3

Tab. 3

Code	Size	Length L [mm]	Stroke H [mm]	Dynamic coefficient C C [N]	Load capacity for a pair of rails Co_{rad} [N]	Weight [kg]
TLR	28	370	380	1578	1596	2,1
		450	460	1860	1882	2,5
		530	540	2045	2068	2,9
		610	620	2711	2744	3,3
		690	700	2933	2968	3,7
		770	780	3084	3120	4,1
		850	860	3180	3218	4,5
		930	940	3259	3264	4,9
		1010	1020	3325	3038	5,3
		1090	1100	3381	2842	5,7
		1170	1180	3428	2670	6,1
		1250	1260	3469	2516	6,5
		1330	1340	3505	2380	6,9
		1410	1420	3537	2258	7,3
		1490	1500	3565	2148	7,7

Tab. 4

Code	Size	Length L [mm]	Stroke H [mm]	Dynamic coefficient C C [N]	Load capacity for a pair of rails Co_{rad} [N]	Weight [kg]
TLR	43	530	540	4075	4156	6,4
		610	620	4241	4326	7,3
		690	700	6155	6278	8,2
		770	780	6554	6686	9,1
		850	860	6870	7008	10
		930	940	7127	7270	10,9
		1010	1020	7341	7488	11,8
		1090	1100	7520	7672	12,7
		1170	1180	7674	7568	13,6
		1250	1260	7807	7148	14,5
		1330	1340	7922	6772	15,4
		1410	1420	8024	6434	16,3
		1490	1500	8115	6130	17,2
		1570	1580	8195	5850	18,1
		1650	1660	8268	5596	19
		1730	1740	8333	5364	19,9
		1810	1820	8393	5150	20,8
		1890	1900	8447	4952	21,7
1970	1980	8497	4768	22,6		

Tab. 5

> TLQ

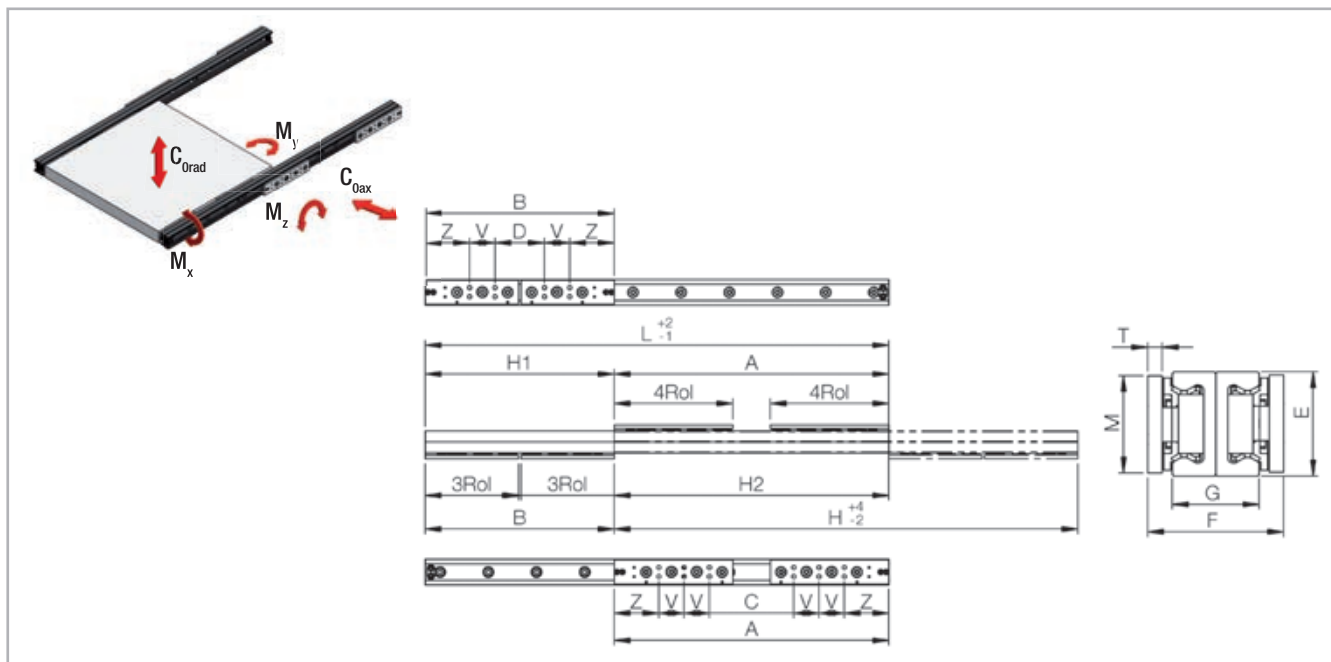

Fig. 28

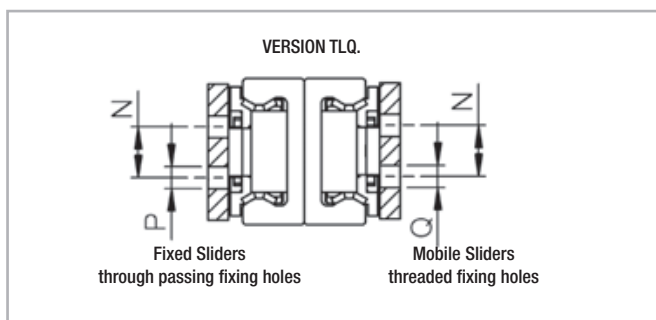

Fig. 29

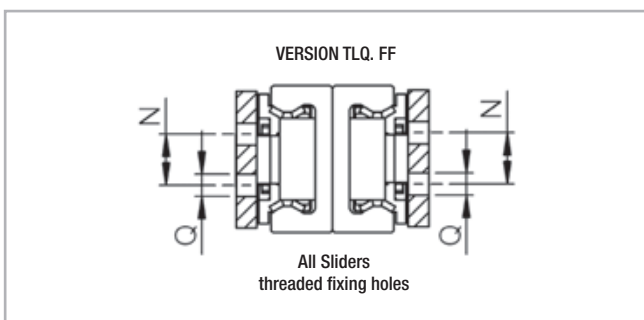

Fig. 30

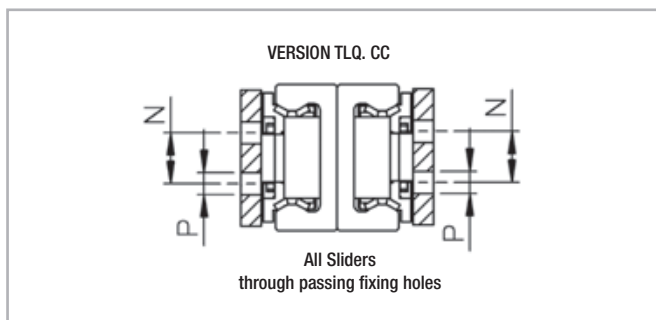

Fig. 31

Code	Size	E [mm]	F [mm]	G [mm]	M [mm]	T [mm]	N [mm]	P [mm]	Q [mm]	Sliders		Z [mm]	V [mm]	Weight [kg/m]	Weight 4 sliders [Kg]
										Type	Length L [mm]				
TLQ	18FF	18	29,4	19	15	3	8	-	M4	3Rol	87	48	21	1,4	0,4
	28	28	36,6	23,9	25	4	10	Ø5,5 for screw M5 DIN912	M5	3Rol	111,5	58	29	2,5	1,5
										4Rol	140,5				
	43	43	56,4	36	40	6	15	Ø6,5 for screw M6 DIN912	M6	3Rol	155	74	42	6	2,4
4Rol										197					

Customized stroke

TLQ slides offer the unique possibility to easily customize the actual stroke H to individual needs. This is obtained by repositioning the slider distance “A” for “Fixed sliders” and distance “B” for “Mobile sliders”, with different distances than indicated on this page. Just keep in mind that distance A is always bigger than B, to maximize the load capacity. By reducing distances between A and B the total stroke increases but the Load capacity decreases, conversely increasing the distance between A and B the total stroke is reduced, while the load capacity increases. Contact ROLLON’s Technical department for load capacities according to customized stroke.

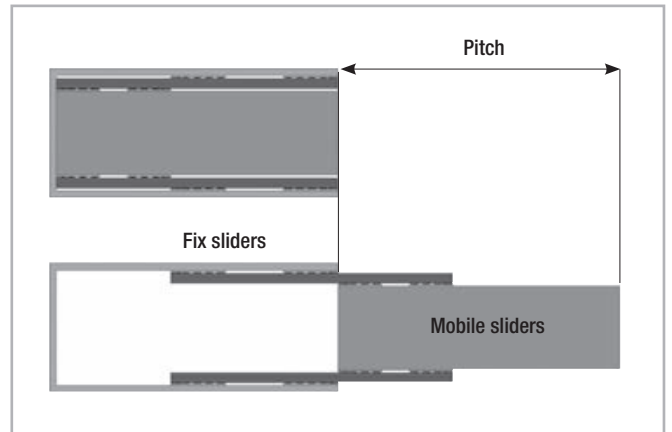

Fig. 32

Installation notes for radial loads

The slide must be installed with the mark “Up-side” facing upwards, when considering RADIAL loads. The sliders attached to structure are marked “Fix-sliders” while the sliders mounted to mobile part are marked “Mobile sliders”. When used in pairs, the same slide can be installed left or right, just by rotating the slide, keeping the mark “Up-side” facing upwards, for radial loads.

Version	Characteristics
BASIC	Cold drawn steel rails with patented “ROLLON-NOX” ; high depth nitride hardening and black oxidation treatment. The rails are cut to size after treatment, so the rail ends are protected by protective spray. The rollers are core hardened steel.
Q	As a basic TLQ product but with additional black “ROLLON e-coating” on the rails, for high corrosion resistance (min 700 hours resistance in salt fog). The rail has no ROLLON e-coating on the raceway contact area with the rollers, as masked before the treatment. The raceways are anyhow with standard oxidation while the wipers with incorporated pre-oiled felt assure lubrication and corrosion protection of raceways.

Tab. 7

Code	Size	L [mm]	H [mm]	Fix sliders			Mobile sliders			Load capacity and moments for a pair of rails					
				A [mm]	C [mm]	H1 [mm]	B [mm]	D [mm]	H2 [mm]	Dynamic coefficient C [N]	Co _{rad} [N]	Co _{ax} [N]	M _x * [Nm]	M _y [Nm]	M _z [Nm]
TLQ	18FF	370	370	185	47	185	185	47	185	725	702	350	6	218	94
		450	450	270	132	180	180	42	270	1159	946	426	6	202	86
		530	530	318	180	212	212	74	318	1267	828	374	6	268	120
		610	610	366	228	244	244	106	366	1343	738	332	6	268	120
		690	690	414	276	276	276	138	414	1400	664	300	6	268	120
		770	770	462	324	308	308	170	462	1445	604	272	6	268	120
		Slider type		All sliders type 3Rol			All sliders type 3Rol								

Tab. 8

* The value Mx refers to a single rail

4 Dimensions and load capacity

Code	Size	L [mm]	H [mm]	Fix sliders			Mobile sliders			Load capacity and moments for a pair of rails					
				A [mm]	C [mm]	H1 [mm]	B [mm]	D [mm]	H2 [mm]	Dynamic coefficient C [N]	Co _{rad} [N]	Co _{ax} [N]	M _x * [Nm]	M _y [Nm]	M _z [Nm]
TLQ	28	450	450	227	53	223	223	49	227	602	928	464	18	192	256
		530	530	307	133	223	223	49	307	1138	1754	876	18	192	256
		610	610	360	128	250	250	76	360	1335	2058	808	18	256	342
		690	690	408	176	282	282	108	408	1458	1916	732	18	316	444
		770	770	456	224	314	314	140	456	1552	1754	670	18	316	546
		850	850	504	272	346	346	172	504	1626	1616	618	18	316	576
		930	930	552	320	378	378	204	552	1687	1500	572	18	316	576
		1010	1010	600	368	410	410	236	600	1737	1398	534	18	316	576
		1090	1090	648	416	442	442	268	648	1779	1310	500	18	316	576
		1170	1170	696	464	474	474	300	696	1814	1232	470	18	316	576
		1250	1250	744	512	506	506	332	744	1845	1162	444	18	316	576
		1330	1330	792	560	538	538	364	792	1872	1100	420	18	316	576
		1410	1410	840	608	570	570	396	840	1896	1044	400	18	316	576
		1490	1490	888	656	602	602	428	888	1917	994	380	18	316	576

Slider type Length 450 e 530 type 3Rol
from Length 610 type 4Rol All sliders type 3Rol

Tab. 9

* The value M_x refers to a single rail

Code	Size	L [mm]	H [mm]	Fix sliders			Mobile sliders			Load capacity and moments for a pair of rails					
				A [mm]	C [mm]	H1 [mm]	B [mm]	D [mm]	H2 [mm]	Dynamic coefficient C [N]	Co _{rad} [N]	Co _{ax} [N]	M _x * [Nm]	M _y [Nm]	M _z [Nm]
TLQ	43	610	600	310	78	300	310	78	300	1529	2228	1114	64	648	864
		690	690	374	142	316	316	84	374	2326	3390	1694	64	680	906
		770	770	456	140	314	314	82	456	3052	4448	2068	64	668	892
		850	850	504	188	346	346	114	504	3305	4816	1916	64	842	1122
		930	930	552	236	378	378	146	552	3509	4978	1784	64	1014	1352
		1010	1010	600	284	410	410	178	600	3676	4656	1668	64	1036	1584
		1090	1090	648	332	442	442	210	648	3816	4374	1568	64	1036	1814
		1170	1170	696	380	474	474	242	696	3935	4126	1478	64	1036	2044
		1250	1250	744	428	506	506	274	744	4037	3902	1398	64	1036	2274
		1330	1330	792	476	538	538	306	792	4126	3702	1326	64	1036	2504
		1410	1410	840	524	570	570	338	840	4204	3522	1262	64	1036	2736
		1490	1490	888	572	602	602	370	888	4272	3358	1204	64	1036	2892
		1570	1570	936	620	634	634	402	936	4334	3210	1150	64	1036	2892
		1650	1650	984	668	666	666	434	984	4389	3072	1102	64	1036	2892
		1730	1730	1032	716	698	698	466	1032	4438	2948	1056	64	1036	2892
		1810	1810	1080	764	730	730	498	1080	4483	2832	1014	64	1036	2892
		1890	1890	1128	812	762	762	530	1128	4524	2726	976	64	1036	2892
1970	1970	1176	860	794	794	562	1176	4561	2626	940	64	1036	2892		

Slider type Length 610 e 690 type 3Rol
from Length 770 type 4Rol All sliders type 3Rol

Tab.10

* The value M_x refers to a single rail

> TLN

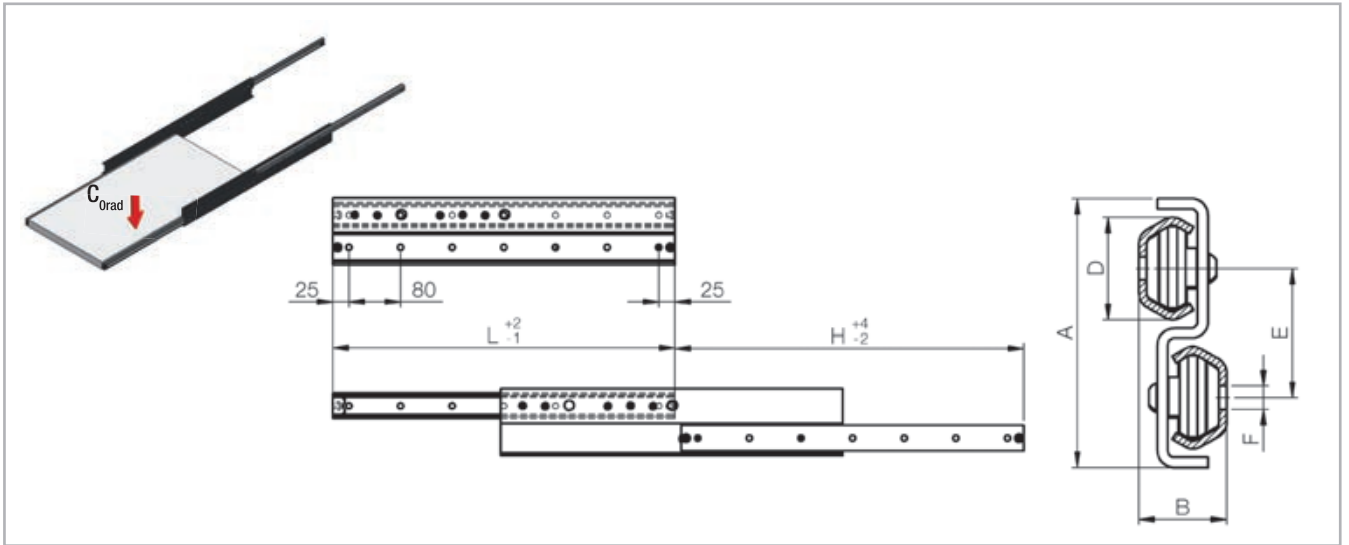

Fig. 33

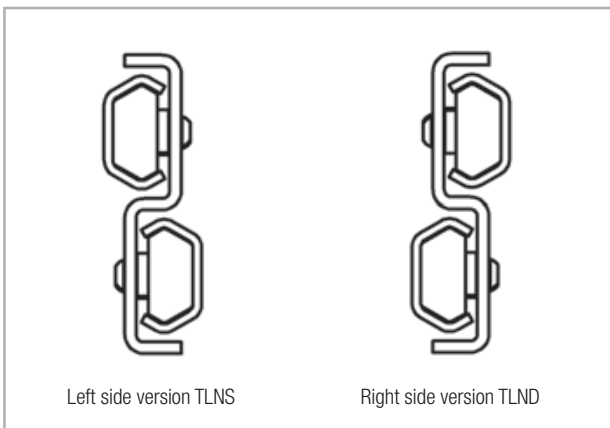

Fig. 34

Code	Size	A [mm]	B [mm]	D [mm]	E [mm]	F [mm]	Fixing screw
TLN	30	76	23,9	29,5	37	Ø 6,5	KIT-40.VC-SP01.0510.ZB
							M5 ISO7380
	40	104	33,8	39,5	50	Ø 9	KIT-40.VC-SP01.0816.ZB
							M8 ISO7380

The fixing holes on TLN are through passing holes for standard Button-head screws ISO 7380 or alternatively very Flat-head ROLLON TORX screws 40.VC-SP01

Tab. 11

Version	Characteristics
BASIC	Roll formed steel rails with patented "ROLLON-NOX" ; nitride hardening and black oxidation treatment. The rails are cut to size after treatment, so the rail ends are protected by protective spray. The rollers are core hardened steel, while the intermediate steel S-element is protected with black epoxy electro coating - "ROLLON e-coating".
Q	As a basic TLN product but with additional black "ROLLON e-coating" on the rails, for high corrosion resistance (min 700 hours resistance in salt fog) . The rail has no ROLLON e-coating on the raceway contact area with the rollers, as masked before the treatment. The raceways are anyhow with standard oxidation while the wipers with incorporated pre-oiled felt assure lubrication and corrosion protection of raceways.
CW o CR	As basic version with colored aesthetic finish ROLLON p-color CW (white color) and CR (red color) offer also a high resistance to corrosion. The treatment is deposited over the entire surface of the guides, toexcept for the raceways that are still protected from oxidation by basic black and the lubricating film, and on the intermediate except.

Tab. 12

4 Dimensions and load capacity

Code	Size	Length L [mm]	Stroke H [mm]	Dynamic coefficient C [N]	Load capacity for a pair of rails Co_{rad} [N]	Weight [kg]	Size	Length L [mm]	Stroke H [mm]	Dynamic coefficient C [N]	Load capacity for a pair of rails Co_{rad} [N]	Weight [kg]
TLN	30	290	300	369	1086	1,2	30HP	450	460	720	2118	1,9
		370	380	431	1266	1,5						
		450	460	480	1412	1,8						
		530	540	516	1516	2,2						
		610	620	540	1588	2,5						
		690	700	560	1646	2,8						
		770	780	570	1676	3,1						
		850	860	578	1700	3,4						
		930	940	583	1714	3,7						
		1010	1020	589	1732	4,0						
		1090	1100	592	1740	4,3						
		1170	1180	596	1752	4,6						
		1250	1260	599	1764	4,9						
		1330	1340	601	1768	5,2						
		1410	1420	604	1776	5,5						
		1490	1500	606	1712	5,8						

Tab. 13

Code	Size	Length L [mm]	Stroke H [mm]	Dynamic coefficient C [N]	Load capacity for a pair of rails Co_{rad} [N]	Weight [kg]	Size	Length L [mm]	Stroke H [mm]	Dynamic coefficient C [N]	Load capacity for a pair of rails Co_{rad} [N]	Weight [kg]
TLN	40	450	460	797	2344	3,7	40HP	610	620	1438	4230	5,1
		530	540	889	2614	4,3						
		610	620	959	2820	4,9						
		690	700	1011	2974	5,5						
		770	780	1051	3090	6,1						
		850	860	1084	3188	6,7						
		930	940	1110	3264	7,3						
		1010	1020	1133	3332	7,9						
		1090	1100	1153	3390	8,5						
		1170	1180	1168	3436	9,1						
		1250	1260	1183	3480	9,7						
		1330	1340	1195	3514	10,2						
		1410	1420	1207	3548	10,8						
		1490	1500	1217	3578	11,4						
		1570	1580	1225	3604	12,0						
		1650	1660	1230	3620	12,6						
		1730	1740	1235	3634	13,2						
		1810	1820	1238	3642	13,8						
1890	1900	1240	3648	14,4								
1970	1980	1244	3636	15,0								

Tab. 14

> TQN

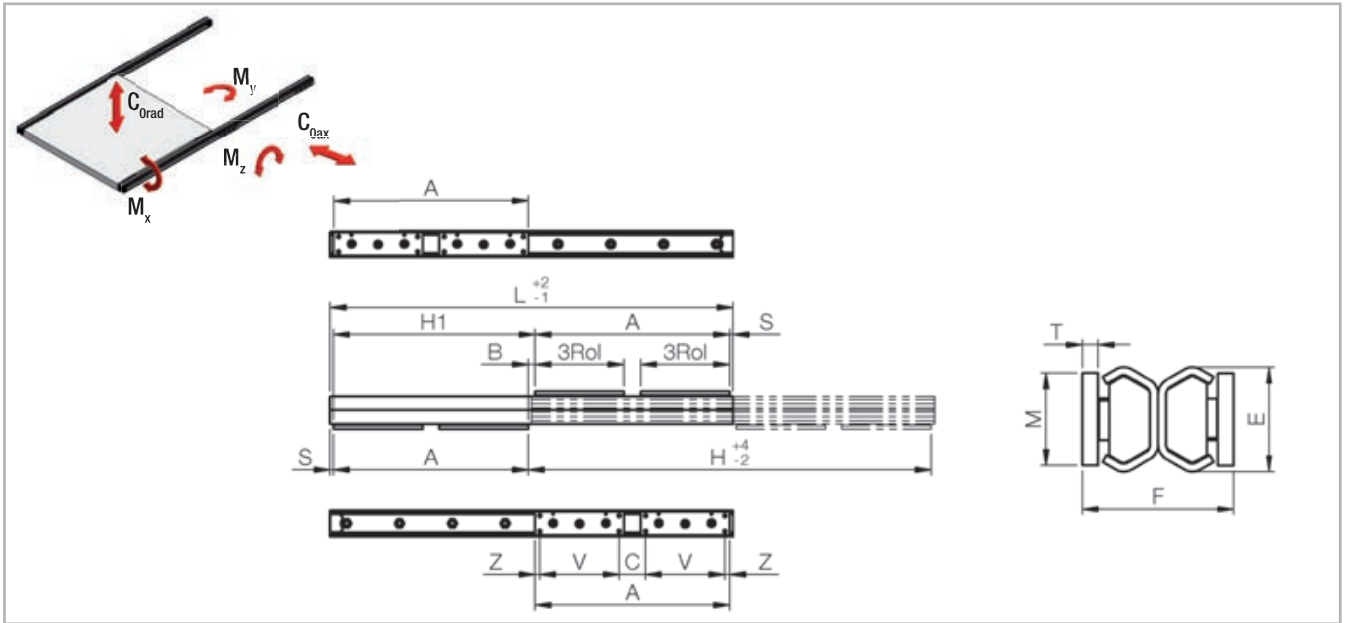

Fig. 35

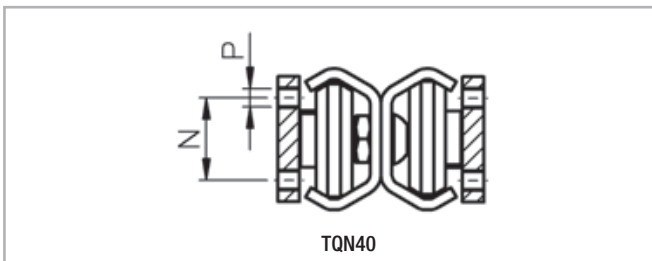

Fig. 36

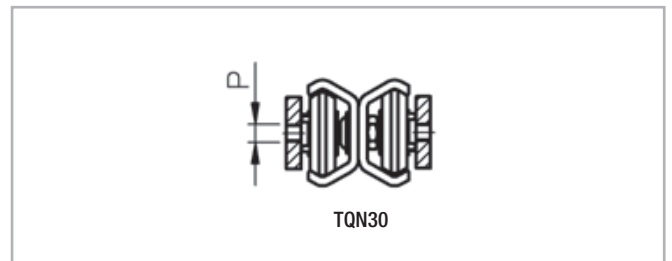

Fig. 37

Code	Size	E [mm]	F [mm]	M [mm]	T [mm]	N [mm]	P [mm]	Sliders		Z [mm]	V [mm]	S [mm]	N° fori	B [mm]	Rail Weight [kg/m]	Weight 4 sliders [Kg]
								Type	Length L [mm]							
TQN	30	29,5	40	20	4	-	M5	3RoL	92	31	30	5	2	10	1,9	0,45
	40	39,5	57,3	35	6	23	M6	3RoL	135	7,5	120	5	4	10	3,1	1,5

Tab. 15

Customized stroke

TQN slides offer the unique possibility to easily customize the actual stroke H, to individual needs by the standard products. This obtained simply by repositioning the slider distance “A” for “Fixed sliders” and “Mobile sliders”, with different distance than indicated on this page. The concept is that by reducing distances the total stroke increases but the Load capacity decreases, conversely increasing the distances the total stroke is reduced, while the load capacity increases. Contact ROLLON’s Technical department for load capacities according to customized stroke. For radial loading the slide must be installed with the mark “Up-side” facing upwards. The sliders fixed to structure are marked “Fix-sliders” while the once fixed to mobile part are marked “Mobile sliders”. When used in pairs, the same slide can be installed left or right, just by rotating the slide, keeping the mark “Up-side” facing upwards for radial loading.

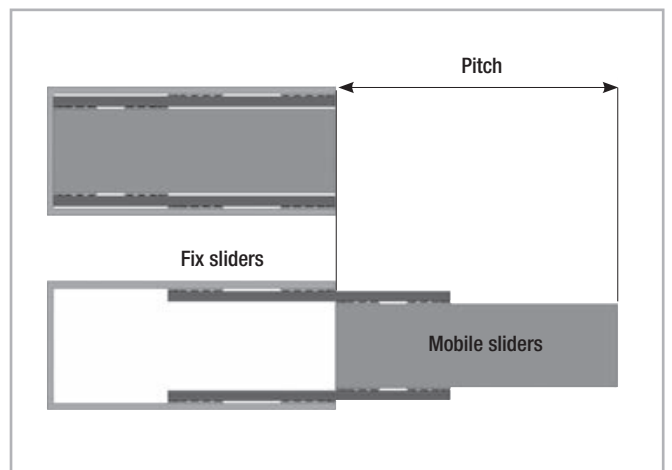

Fig. 38

4 Dimensions and load capacity

Version	Characteristics
BASIC	Roll formed steel rails with patented "ROLLON-NOX"; nitride hardening and black oxidation treatment. The rails are cut to size after treatment, so the rail ends are protected by protective spray. The rollers are core hardened steel.
Q	As a basic TQN product but with additional black "ROLLON e-coating" on the rails, for high corrosion resistance (min 700 hours resistance in salt fog). The rail has no ROLLON e-coating on the raceway contact area with the rollers, as masked before the treatment. The raceways are anyhow with standard oxidation while the wipers with incorporated pre-oiled felt assure lubrication and corrosion protection of raceways.
CW o CR	As basic version with colored aesthetic finish ROLLON p-color CW (white color) and CR (red color) offer also a high resistance to corrosion. The treatment is deposited over the entire surface of the guides, toexcept for the raceways that are still protected from oxidation by basic black and the lubricating film, and on the intermediate except.

Tab. 16

Code	Size	L [mm]	H [mm]	Fix & Mobile sliders			Load capacity and moments for a pair of rails					
				A [mm]	C [mm]	H1 [mm]	Dynamic coefficient C [N]	Co _{rad} [N]	Co _{ax} [N]	M _x * [Nm]	M _y [Nm]	M _z [Nm]
TQN	30	450	450	215	93	225	419	1234	432	8	174	246
		530	530	255	133	265	463	1362	476	8	228	326
		610	610	295	173	305	494	1324	508	8	228	406
		690	690	335	213	345	517	1190	532	8	228	472
		770	770	375	253	385	535	1080	520	8	228	472
		850	850	415	293	425	550	990	478	8	228	472
		930	930	455	333	465	562	914	440	8	228	472
		1010	1010	495	373	505	572	848	408	8	228	472
		1090	1090	535	413	545	580	790	382	8	228	472
		1170	1170	575	453	585	587	740	358	8	228	472
		1250	1250	615	493	625	593	696	336	8	228	472
		1330	1330	655	533	665	599	658	318	8	228	472
		1410	1410	695	573	705	603	624	300	8	228	472
1490	1490	735	613	745	608	592	286	8	228	472		
Slider type				All sliders type 3RoI								

Tab. 17

* The value M_x refers to a single rail

Code	Size	L [mm]	H [mm]	Fix & Mobile sliders			Load capacity and moments for a pair of rails					
				A [mm]	C [mm]	H1 [mm]	Dynamic coefficient C [N]	Co _{rad} [N]	Co _{ax} [N]	M _x * [Nm]	M _y [Nm]	M _z [Nm]
TQN	40	610	610	295	40	305	405	2382	834	20	562	640
		690	690	335	80	345	440	2592	906	20	562	800
		770	770	375	120	385	468	2516	964	20	562	960
		850	850	415	160	425	490	2314	1008	20	562	1120
		930	930	455	200	465	508	2142	1044	20	562	1152
		1010	1010	495	240	505	522	1994	972	20	562	1152
		1090	1090	535	280	545	535	1864	910	20	562	1152
		1170	1170	575	320	585	545	1750	854	20	562	1152
		1250	1250	615	360	625	554	1650	806	20	562	1152
		1330	1330	655	400	665	562	1562	762	20	562	1152
		1410	1410	695	440	705	569	1480	722	20	562	1152
		1490	1490	735	480	745	576	1408	686	20	562	1152
		1570	1570	775	520	785	581	1342	654	20	562	1152
		1650	1650	815	560	825	586	1282	626	20	562	1152
		1730	1730	855	600	865	591	1228	600	20	562	1152
		1810	1810	895	640	905	595	1178	574	20	562	1152
		1890	1890	935	680	945	599	1132	552	20	562	1152
		1970	1970	975	720	985	602	1088	532	20	562	1152
		Slider type		All sliders type 3RoI								

Tab. 18

* The value M_x refers to a single rail

> TLAX

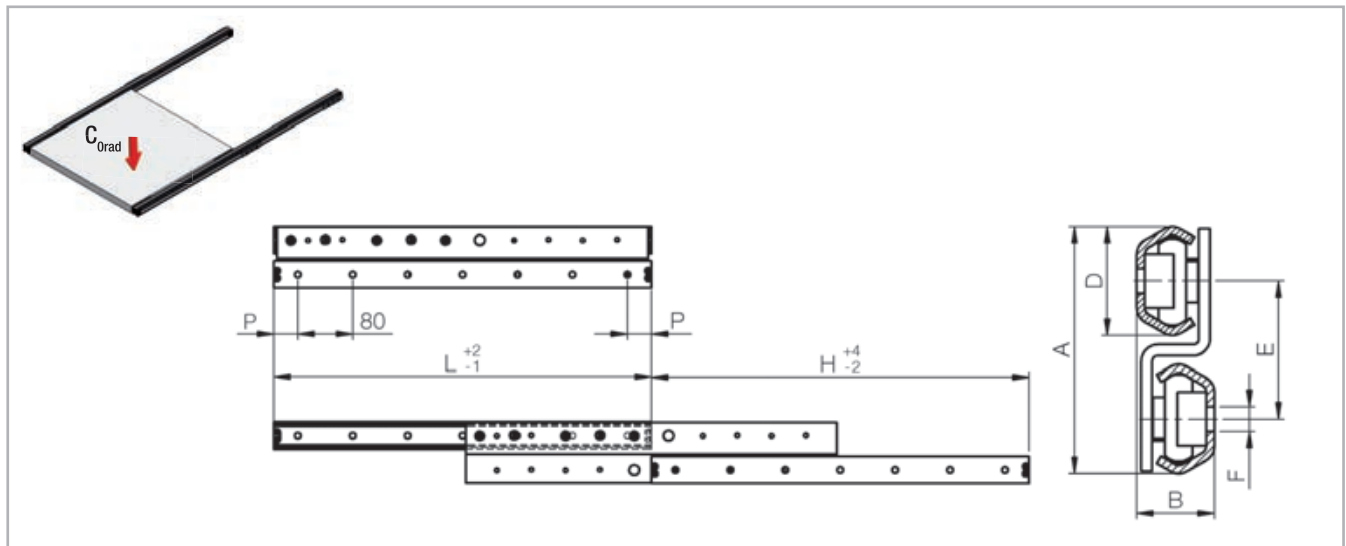

Fig. 39

Code	Size	A [mm]	B [mm]	D [mm]	E [mm]	F [mm]	Type of Fixing screws
TLAX	26	65	23	26	35	Ø 6,5	KIT-40.VC-SP01.0510.ZB M5 ISO7380
	40	90	28,3	39,5	50	Ø 9	KIT-40.VC-SP01.0816.ZB M8 ISO7380

Tab. 19

The fixing holes on TLAX are through passing holes for standard Button-head screws ISO 7380 or alternatively very Flat-head ROLLON TORX screws 40.VC-SP01 TLAX must be mounted with upper rail fixed to structure and

the movable lower rail fixed to the moving part. When used in pairs the same slide can be used both left and right side on mobile part, just by turning around the slide .

Version	Characteristics
BASIC	Rails and intermediate S-element in AISI304 . Rollers in hardened AISI440C .
X	As Basic version, but rails and intermediate S-element completely Electro-Polished for very high corrosion resistance, 1000hours in salt fog . The Electro Polishing also gives the product a very shiny surface.

Tab. 20

Code	Size	Length L [mm]	Stroke H [mm]	P [mm]	N° of Y-access holes	Load capacity for a pair of rails Co_{rad} [N]	Weight [kg]
TLAX	26	300	300	30	4	640	1,2
		350	350	55	4	800	1,4
		400	400	40	5	914	1,5
		450	450	25	6	1000	1,7
		500	500	50	6	1066	1,9
		550	550	35	7	1120	2,1
		600	600	20	8	1164	2,3
		650	650	45	8	1200	2,4
		700	700	30	9	1230	2,6
		750	750	55	9	1258	2,8
		800	800	40	10	1280	3
		850	850	25	11	1300	3,2
		900	900	50	11	1318	3,3
		1000	1000	20	13	1330	3,7
		1100	1100	30	14	1218	4,1
1200	1200	40	15	1124	4,4		

Tab. 21

Code	Size	Length L [mm]	Stroke H [mm]	P [mm]	N° of Y-access holes	Load capacity for a pair of rails Co_{rad} [N]	Weight [kg]
TLAX	40	500	500	50	6	1504	3,4
		550	550	35	7	1684	3,7
		600	600	20	8	1828	4,1
		650	650	45	8	1948	4,4
		700	700	30	9	2048	4,7
		750	750	55	9	2134	5
		800	800	40	10	2206	5,3
		850	850	25	11	2270	5,7
		900	900	50	11	2328	6
		1000	1000	20	13	2422	6,6
		1100	1100	30	14	2316	7,3
		1200	1200	40	15	2144	7,9
		1300	1300	50	16	1996	8,5
		1400	1400	20	18	1868	9,2
		1500	1500	30	19	1754	9,8
1600	1600	40	20	1654	10,5		

Tab. 22

> TQAX

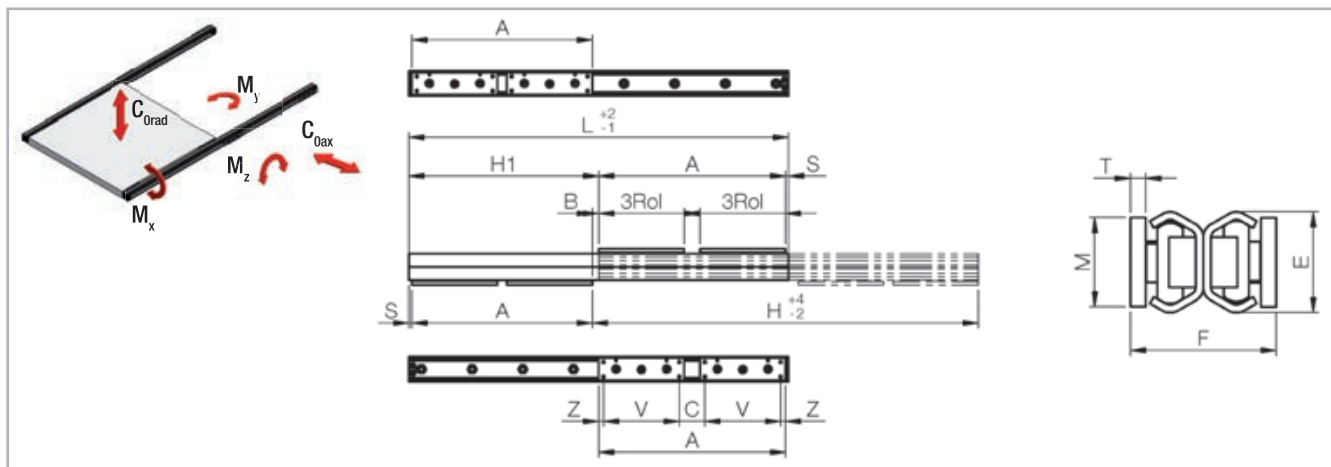

Fig. 40

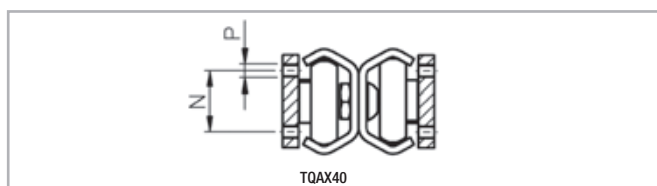

Fig. 41

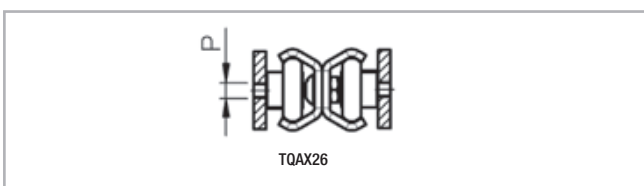

Fig. 42

Code	Size	E [mm]	F [mm]	M [mm]	T [mm]	N [mm]	P [mm]	Sliders		Z [mm]	V [mm]	S [mm]	N° holes	B [mm]	Rail weight [kg/m]	Weight 4 sliders [Kg]
								Type	Length [mm]							
TQAX	26	26	44	25	4	-	M5	3Rol	80	25	30	14	2	28	1,6	0,4
	40	39,5	57,3	35	6	23	M6	3Rol	135	7,5	120	0	4	0	3,1	1,5

Tab. 23

Customized stroke

TQAX slides offer the unique possibility to easily customize the actual stroke H, to individual needs by the standard products. This obtained simply by repositioning the slider distance “A” for “Fixed sliders” and “Mobile sliders”, with different distance than indicated on this page. The concept is that by reducing distances the total stroke increases but the Load capacity decreases, conversely increasing the distances the total stroke is reduced, while the load capacity increases. Contact ROLLON's Technical department for load capacities according to customized stroke. For radial loading the slide must be installed with the mark “Up-side” facing upwards. The sliders fixed to structure are marked “Fix-sliders” while the once fixed to mobile part are marked “Mobile sliders”. When

used in pairs, the same slide can be installed left or right, just by rotating the slide, keeping the mark “Up-side” facing upwards for radial loading.

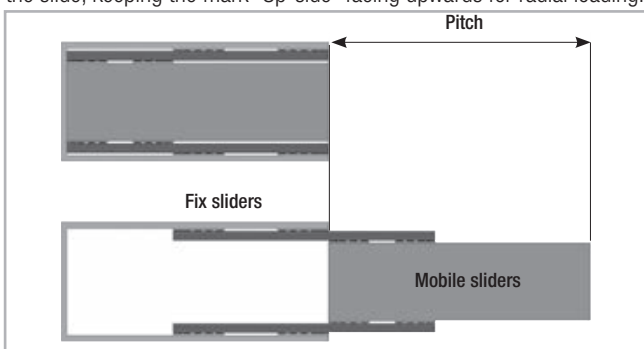

Fig. 43

Version	Characteristics
BASIC	Roll formed inox rails in AISI304 . Rollers in hardened AISI440C .
X	As Basic version, but rails and intermediate S-element completely Electro-Polished for very high corrosion resistance, 1000hours in salt fog. The Electro Polishing also gives the product a very shiny surface.

Tab. 24

Code	Size	L [mm]	H [mm]	Fix & Mobile sliders			Load capacity and moments for a pair of rails				
				A [mm]	C [mm]	H1 [mm]	Co _{rad} [N]	Co _{ax} [N]	M _x * [Nm]	M _y [Nm]	M _z [Nm]
TQAX	26	400	400	172	62	200	836	292	6	98	144
		450	450	197	87	225	932	326	6	124	184
		500	500	222	112	250	1008	352	6	152	224
		550	550	247	137	275	956	374	6	170	264
		600	600	272	162	300	890	390	6	170	304
		650	650	297	187	325	830	406	6	170	316
		700	700	322	212	350	780	418	6	170	316
		750	750	347	237	375	734	394	6	170	316
		800	800	372	262	400	694	372	6	170	316
		850	850	397	287	425	658	352	6	170	316
		900	900	422	312	450	626	334	6	170	316
		950	950	447	337	475	596	318	6	170	316
		1000	1000	472	362	500	568	304	6	170	316
		1100	1100	522	412	550	522	280	6	170	316
1200	1200	572	462	600	482	258	6	170	316		

Slider type All sliders type 3Rol

Tab. 25

* The value Mx refers to a single rail

Code	Size	L [mm]	H [mm]	Fix & Mobile sliders			Load capacity and moments for a pair of rails				
				A [mm]	C [mm]	H1 [mm]	Co _{rad} [N]	Co _{ax} [N]	M _x * [Nm]	M _y [Nm]	M _z [Nm]
TQAX	40	600	600	300	45	300	1978	692	18	468	526
		650	650	325	70	325	2082	728	18	468	606
		700	700	350	95	350	2170	760	18	468	686
		750	750	375	120	375	2168	786	18	468	766
		800	800	400	145	400	2052	808	18	468	846
		850	850	425	170	425	1948	828	18	468	926
		900	900	450	195	450	1854	846	18	468	960
		950	950	475	220	475	1768	860	18	468	960
		1000	1000	500	245	500	1690	824	18	468	960
		1100	1100	550	295	550	1554	758	18	468	960
		1200	1200	600	345	600	1438	702	18	468	960
		1300	1300	650	395	650	1338	652	18	468	960
		1400	1400	700	445	700	1250	610	18	468	960
		1500	1500	750	495	750	1174	572	18	468	960
1600	1600	800	545	800	1106	540	18	468	960		

Slider type All sliders type 3Rol

Tab. 26

* The value Mx refers to a single rail

> Sizing of telescopic applications

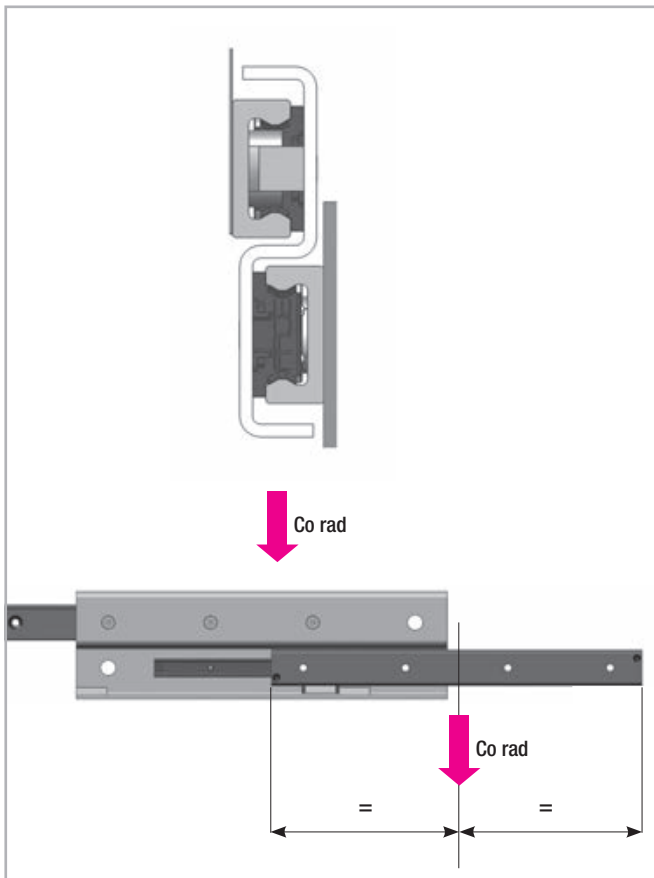

Fig. 44

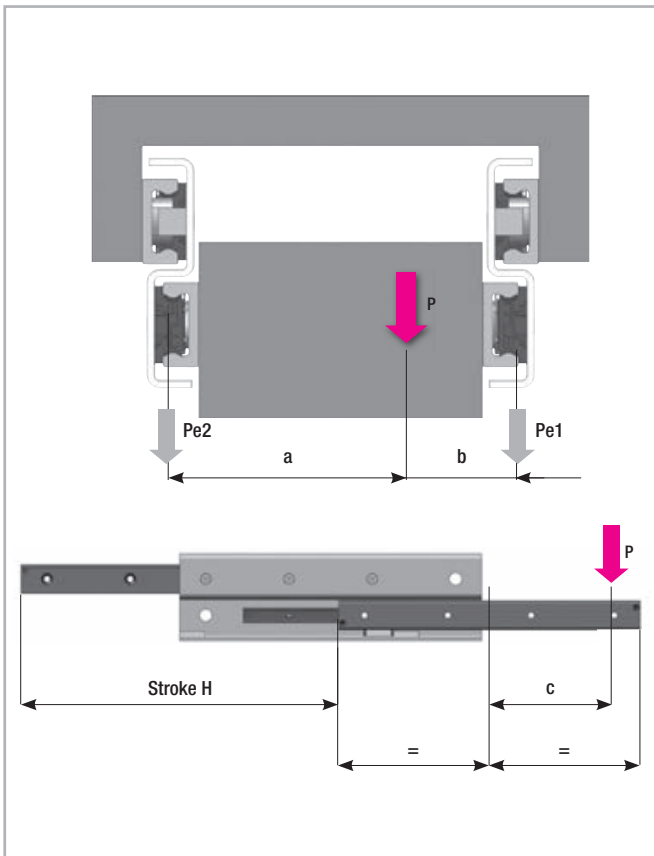

Fig. 45

The main factors for sizing the slides for a telescopic movement:

- The weight/forces of mobile part and their position compared to slides.
- Presence of dynamic forces / eventual abuse
- max. acceptable flexion
- max. acceptable extraction/closing force of mobile part
- Ambients, frequency, speed
- Expected lifetime

All load capacities Co_{rad} , are indicated per pair of slides and with the load perfectly centered. I.e an homogeneous load placed between 2 slides. Hereby the load P is acting as a radial point load, at half the extension and in the middle between the 2 slides. The load capacity for a single is then:

$$P = \frac{Co_{rad}}{2}$$

When sizing a telescopic application, it must be carefully evaluated if the load is centered. Also it must be considered if any external dynamic forces, or possible abuse could further increase the load forces acting on the slides.

In case the load isn't centered. i.e. load center Pe_1 more towards one of the slides, and/or more towards the tip of the load, the center weighted load must be calculated

$= Pe_1$, to be inserted in formula on next page.

$$Pe_1 = \frac{(P \cdot a)}{(a + b)}$$

Where :

P = Weight/load of mobile part

a, b = distances from centered load to left/right slide

fp = load position coefficient, based on relation of "c" distance between actual load P and load Co_{rad} position, compared stroke H .

The coefficient fp is obtained from below diagram. as the ratio between "c/H".

When only 1 slide the formula is $Pe = P \cdot fp$ $Pe = P \cdot fp$

Capacity load reduction - According to the position of the load p

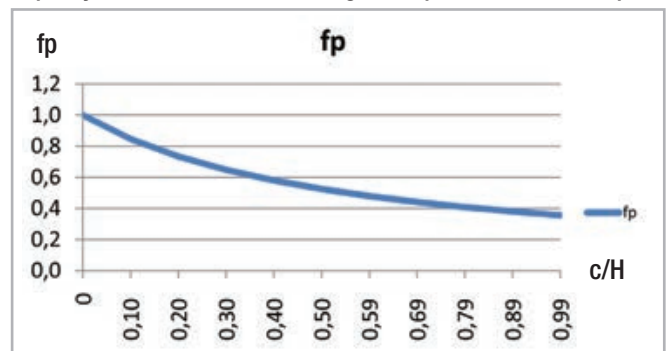

Fig. 46

> Verification of load capacity

To assure a correct selection of the slides according to the slide's load capacity, it is assumed the known different forces acting on the slides, which then must be decomposed in : radial, axial or moment forces. Then again compared to load/moment capacities indicated for each single product in previous pages. For the slides with intermediate element TLR, TLN and TLAX the verification is mainly down to comparing the load capacity $Co\ Rad.$ to Pe including a safety factor Z .

$$Pe \leq Co\ rad / Z$$

Where Z is the safety coefficient as per below table

Safety coefficient - Z	Application conditions
1-1,5	Precise calculation of load/forces, precise assembly and rigid structures
1,5-2	Intermediate conditions
2-3,5	Roughly estimation of load/forces, not precise and not rigid structures

Tab. 27

> **Lifetime calculation**

Theoretical lifetime calculation

The theoretical life of the rollers and raceways of rail should be determined by the conventional formula as indicated below in km of running, however, should keep in mind that the value thus calculated must be taken with caution just for orientation, in fact, the real service life achieved can be very different from that calculated value, because the phenomena of wear and fatigue are caused by factors not easy to predetermine, for example:

- Inaccuracy in the estimation of the real loading condition
- Overloading for inaccuracies in assembling
- Vibration, shock and dynamic pulse stress
- Raceways status of lubrication
- Thermal excursions
- Environmental pollution and dust
- Damage mounting
- Stroke length and frequency of movement

$$L_{cy} = 50 \cdot \left(\frac{C}{P} \cdot \frac{1}{f_i} \right)^3 \cdot \frac{1}{H} \cdot 10^6$$

Where:

L_{cy} = N° of cycles open/close

C = Dynamic load coefficient

P = Weight/load of single rail (N)

H = Stroke (mm)

f_i = Coefficient taking into account operational ambient and level of correct lubrication

The correction factor f_i applied to the theoretical calculation formula have the sole purpose of guiding the designer qualitatively on the influence in the lifetime estimation of the real application conditions without any pretense of precision. For more details please contact Rollon's technical department.

The slides TLAX and TQAX is expected to reach approx. 100.000 cycles, with a load of 70% of max load capacity.

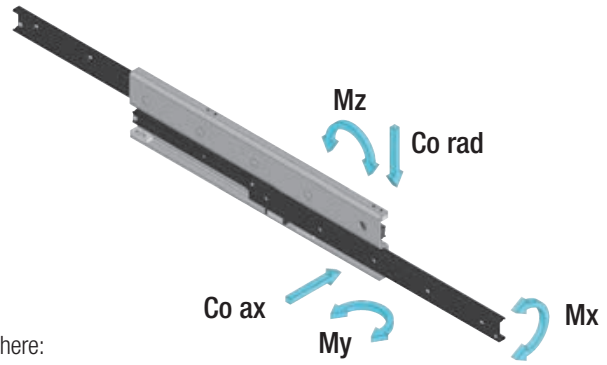

Where:

Pe rad = applied radial load

Pe ax = applied axial load

Mex, Mey, Mez = applied moments

Co rad = radial load capacity

Co ax = axial load capacity

Mx, My, Mz = moment capacities

For full telescopic slides TLQ, TQN and TQAX, the calculation might also includes moments.

$$\left(\frac{Pe\ ax}{Co\ ax} + \frac{Pe\ rad}{Co\ rad} + \frac{Mex}{Mx} + \frac{Mey}{My} + \frac{Mez}{Mz} \right) \leq \frac{1}{Z}$$

Coefficient fi	Operating conditions
1-1.5	Correct load sizing, rigid structures, constant good lubrication, clean ambient
1.5-2	Intermediate conditions
2-3.5	Approximative load sizing, unprecise non rigid structures, dusty not clear ambient.

Tab. 28

The actual lifetime very much depends on constant good lubrication of the raceways. Without good constant lubrication and/or in very dusty ambients the actual lifetime expectations can be much reduced.

Calculation of load P to be used for lifetime calculation

The load P to be used in below formular is referred to single slide, with load in the centre. If used in pair, load on each single slide must be calculated.

The slides TLQ, TQN might include moments Mex, Mey and Mez, in addition to radial and axial loads. The formula in case of moments is:

$$Pe = Co\ rad \cdot \left(\frac{Pe\ rad}{Co\ rad} + \frac{Pe\ ax}{Co\ ax} + \frac{Mex}{Mx} + \frac{Mey}{My} + \frac{Mez}{Mz} \right)$$

Ordering key



> Telerace guides

TLR	D	28	A	1490	Q	
						Optional treatments <i>see pg. TLR-6ff</i>
						Length <i>see pg. TLR-6ff</i>
						HP = High Performance (Only TLN) A = Self-aligning (Only TLR) FF = all threaded holes CC= all passing holes (only TLQ)*
						Size <i>see pg. TLR-6ff</i>
						Right (D) or left (S) - (only for series TLR and TLN)
						Product type <i>see pg. TLR-6ff</i>

Ordering example: TRL e TLN: TLRD43-1010-Q; TLRS26A-1010-K; TLND40-1010-CW; TLNS30HP-690

Ordering example: TLQ: TLQ43-1010-Q; TLQ18FF-0690; TLQ43CC-1170-Q

Ordering example: TQN, TLAX, TQAX: TQN40-1010-CR; TLAX40-1300; TQAX40-1000

Note on ordering: fill in data related to HP, A, FF and CC versions only if needed. Rail lengths and stroke lengths are always stated with 4 digits.

Please pad with zeroes to fill in for lengths with less than 4 digits, e.g. 515mm length is "0515"

* The guide TLQ size 18 is only available in the FF versions with slider with all threaded holes.

ROLLON[®]
BY TIMKEN

Light Rail

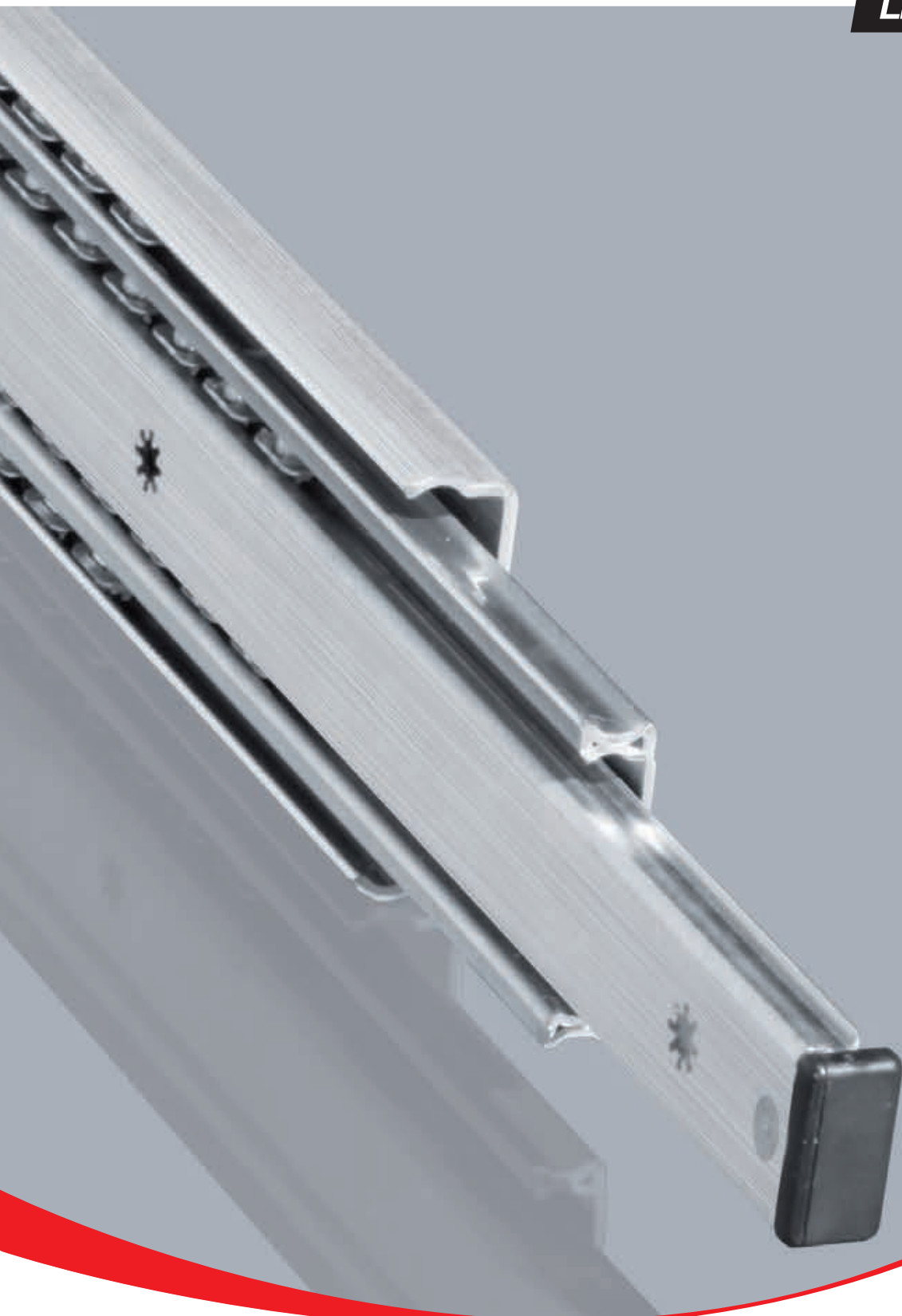

Product explanation



> Light telescopic rails, with full or partial extension



Fig. 1

The Light Rail product family consists of 3 series with full and partial extensions in a lightweight design. It is ideal for applications in which the mass of the rail is just as important as the bending rigidity.

The most important characteristics:

- Light and quiet running with heavy loads
- Long service life without maintenance
- Effective self-cleaning of the ball track
- High functional reliability
- Structural elasticity capable of absorbing minor impacts and absence of permanent deformation
- Not sensitive to side impacts

Preferred areas of application:

- Beverage industry
- Automotive
- Construction and machine technology (e.g., housing)
- Packaging machines
- Railcars (e. g., maintenance and battery extensions)
- Special machines

LPS 38

Partial extension with rails made of hot-dipped galvanized steel and plastic ball cages.



Fig. 2

LFS 46

Detachable internal rail which can be released with a latch. Rails are made of bright chrome-plated steel, the ball cages of steel and plastic. Roll back protection in closed position.



Fig. 3

LFS 57

Full extension with rails made of hot-dipped galvanized steel and zinc-plated steel ball cages. Roll back protection in closed position.



Fig. 4

LFS 58 SC

Full extension with automatic retraction and damping. The automatic retraction system is assisted by a spring-loaded mechanism that allows the rail to get back to a complete retraction before reaching the closed position.



Fig. 5

LFS 70

Full extension with rails made of zinc-plated galvanized and blue passivated steel. The ball cages are made of zinc-plated steel. Heavy load end stop in opened and closed position. Roll back protection in closed position.



Fig. 6

LFX 27

The stainless steel full extension consists of two inner guide rails that, connected to a double-T profile, form the intermediate element and two outer rails that form the connection to the connecting construction as fixed and moving element. The square cross-section allows a compact design of high load ratings and low deflection.



Fig. 7

Overview product cross sections



> Partial extension guides

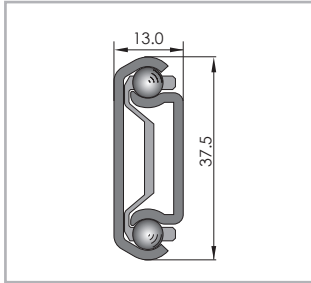

Fig. 8

LPS38

Load capacities p. LR-6

> Full extension guides

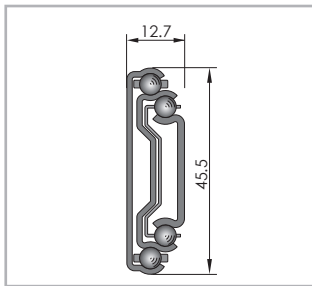

Fig. 9

LFS46

Load capacities p. LR-7

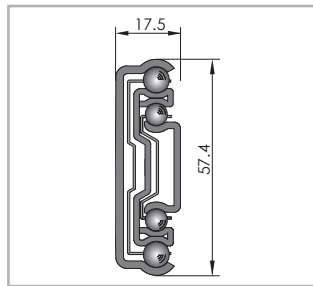

Fig. 10

LFS57

Load capacities p. LR-8

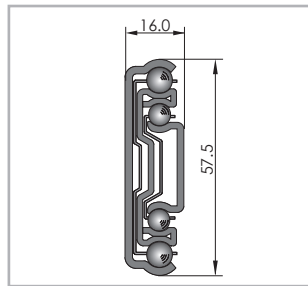

Fig. 11

LFS58 SC

Load capacities p. LR-9

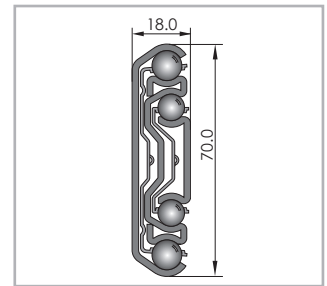

Fig. 12

LFS70

Load capacities p. LR-10

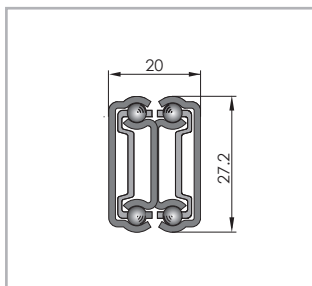

Fig. 13

LFX27

Load capacities p. LR-11

Technical data

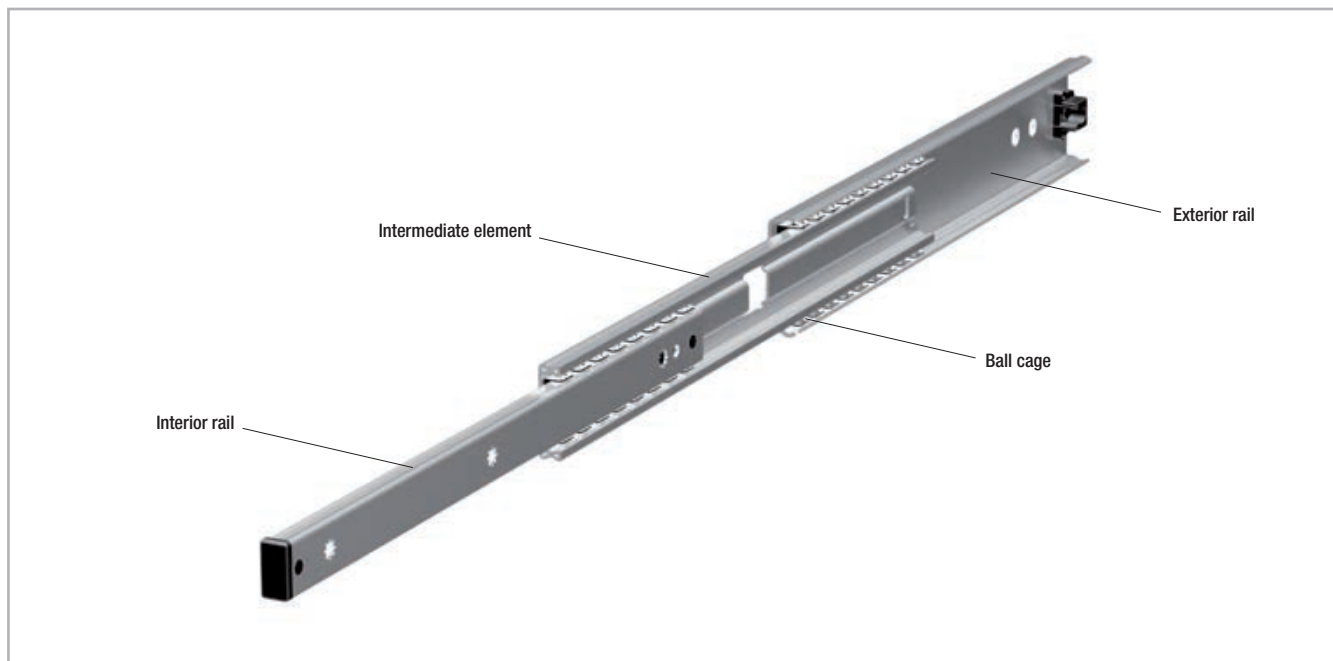

Fig. 14

Performance characteristics:

- Extension speed (depending on application):
 - Extension distance 100 - 500 mm: max. 0.5 m/s (19.69 in/s)
 - Extension distance 600 mm: max. 0.4 m/s (15.75 in/s)
 - Extension distance 700 mm: max. 0.3 m/s (11.81 in/s)
- LFS 58 SC series with automatic retraction
- Temperature range: from +10 °C to +40 °C, for LFX from -30° to +200° C.
- Temporary storage and transport temperature: -20 °C to max. +80 °C (-4 °F to +176 °F)
- All systems are lubricated for life
- LFS/LPS rail material: hot galvanized or chromed steel
- LFS/LPS ball bearing cage material: galvanized steel or plastic
- LFS/LPS ball bearing material: hardened carbon steel
- LFX rail, balls and cage material: stainless steel 1.4301

Remarks:

- All load capacity data are based on a pair of telescopic rails
- Horizontal movement installation is recommended
- Vertical movement installation on request
- Assembly in cross-sectional width, here a positive tolerance of +0.5 mm is recommended (mounted under tension). If the extensions are installed with too small a tolerance, the service life is decreased
- Cycle data applies to the use of an extension pair (recommended)
- Vertical use of extensions (radial load) is recommended
- If mounted in a horizontal position, the load capacity will be reduced (see p. LR-13)
- Cathodic edge protection, additional corrosion protection with powder coating on request
- Roll back protection in closed position is friction locked (except LPS 38)
- Not suitable for moments – must be used as extension pair

Dimensions and load capacity



> LPS 38

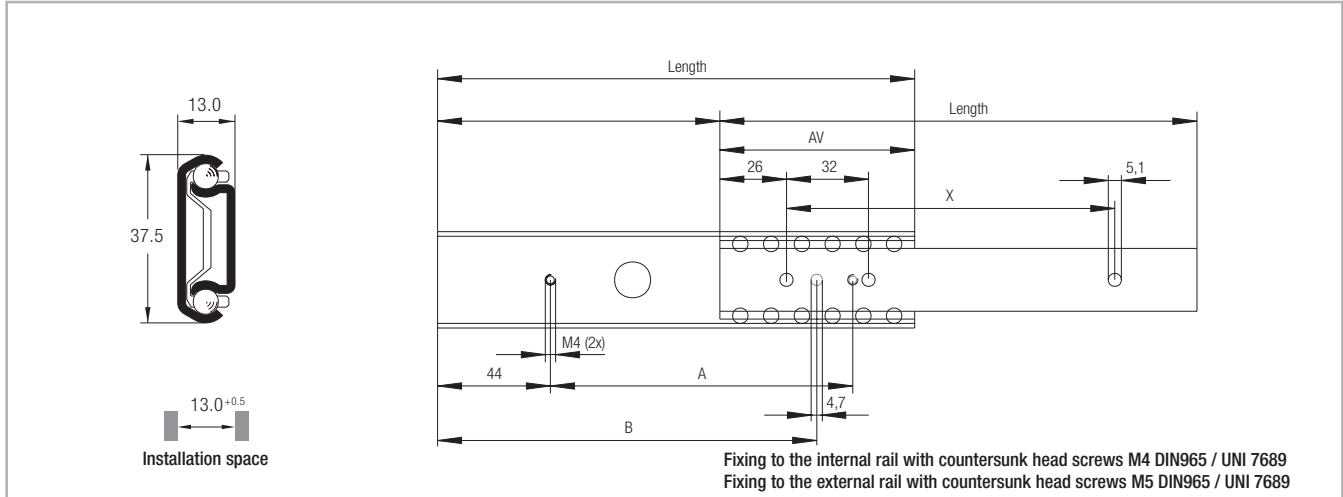

All dimensions given in mm

Fig. 15

Type	Size	Length [mm]	Extension loss AV [mm]	Stroke* [mm]	A [mm]	B [mm]	X [mm]	Load capacity for a pair of rails		Weight per single guide [kg]
								C_{0rad} [N]	C_{0ax} [N]	
LPS	38	242	88	154	166	202	192	350	100	0.30
		317		229	241	277	256			0.40
		398	100	298	322	358	352			0.50
		473		373	397	433	416			0.60

* The stroke is the difference of the length and the extension loss AV

Tab. 1

Note: The given load capacities are guidelines with 100,000 cycles and uniform load distribution (area load) when using all mounting holes. The load values must be reduced in unfavorable conditions.

> LFS 46

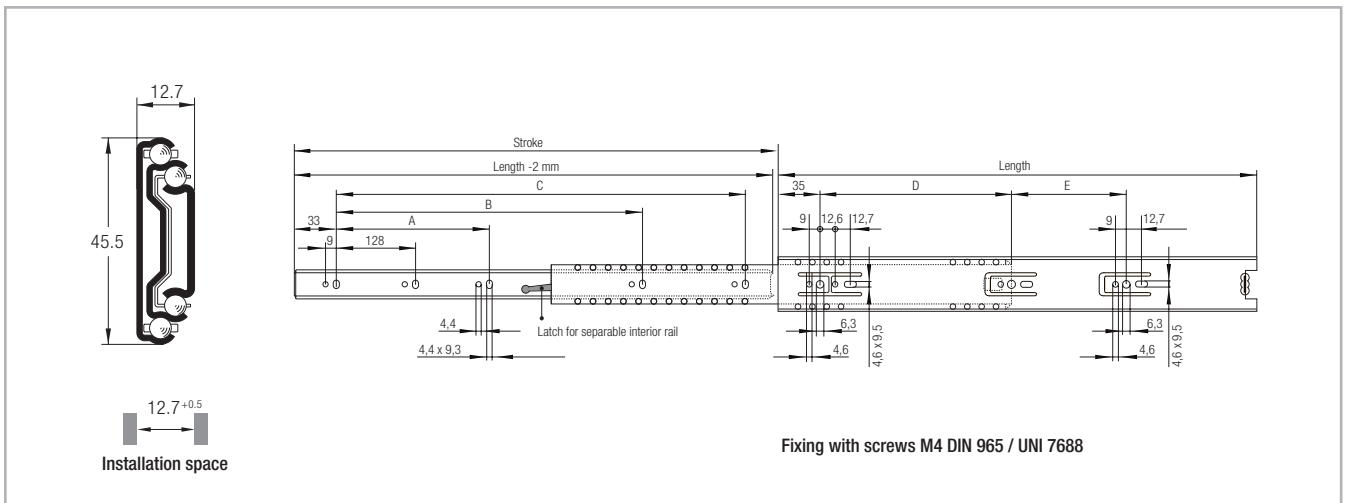

All dimensions given in mm

Fig. 16

Type	Size	Length	Stroke	A	B	C	D	E	Load capacity for a pair of rails	Load capacity for a pair of rails	Weight per single guide
		[mm]	[mm]	[mm]	[mm]	[mm]	[mm]	[mm]	C_{0rad} [N]	C_{0ax} [N]	[kg]
LFS	46	300	305	-	-	242	192	-	300	100	0,48
		350	356	-	-	292	256	-	300		0,505
		400	406	-	256	342	160	96	350		0,64
		450	457	-		392		160			0,71
		500	508	-	352	442	224	128	400		0,79
		550	559	224	416	492		192			0,88
		600	610			542		224			0,95

Tab. 2

Note: The given load capacities are guidelines with 50,000 cycles and uniform load distribution (area load) when using all mounting holes. The load values must be reduced in unfavorable conditions.

> LFS 57

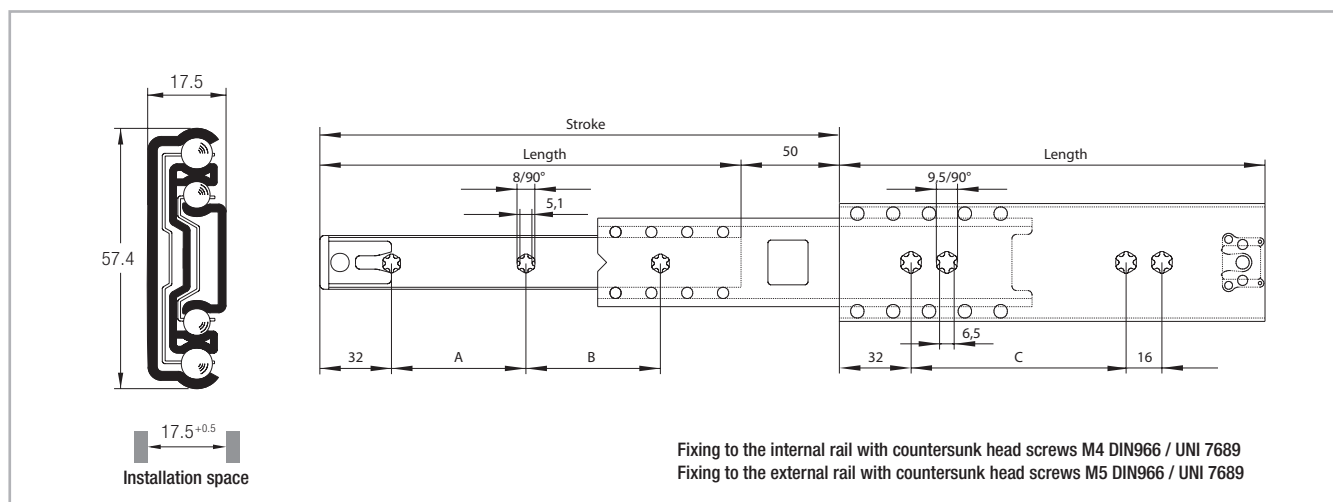

All dimensions given in mm

Fig. 17

Type	Size	Length	Stroke*	A	B	C	Load capacity for a pair of rails	Load capacity for a pair of rails	Weight per single guide
		[mm]	[mm]	[mm]	[mm]	[mm]	C_{0rad} [N]	C_{0ax} [N]	
LFS	57	300	350	128	104	256	500	160	0.84
		350	400		152		600		0.98
		400	450	160	168	384	650		1.13
		450	500		224		700		1.27
		500	550	224	208	800	750		1.42
		550	600		256		1.57		
		600	650	288	240	800	800		1.71
		650	700		288				1.86
		700	750	320	312	800	800		2.01
750	800	360	2.16						

* The stroke is the sum of the length and the over extension

Tab. 3

Note: The given load capacities are guidelines with 100,000 cycles and uniform load distribution (area load) when using all mounting holes. The load values must be reduced in unfavorable conditions.

> LFS 58 SC

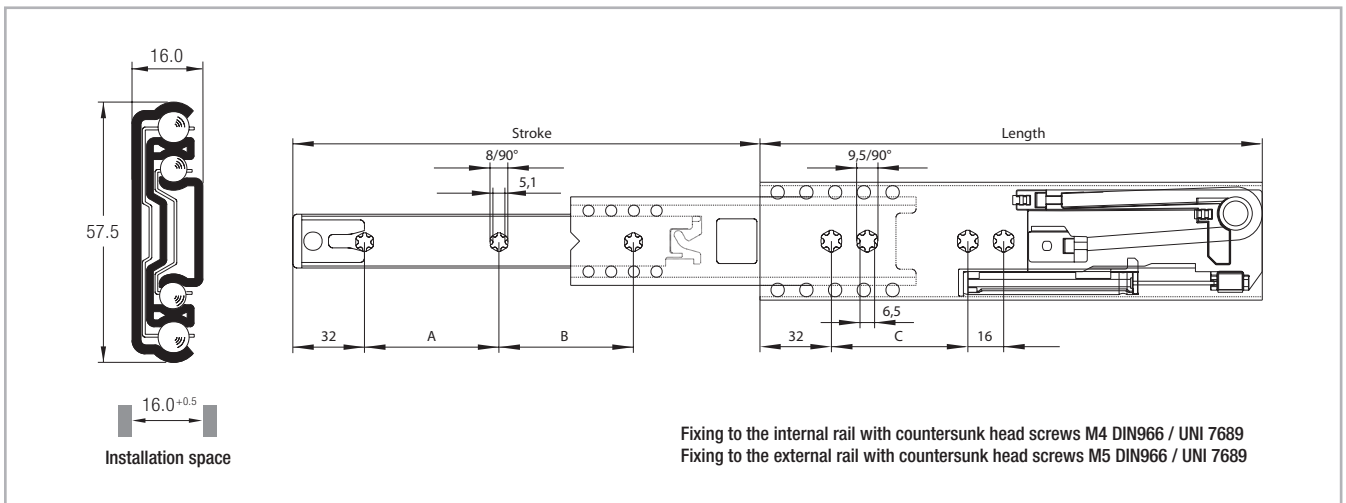

All dimensions given in mm

Fig. 18

Type	Size	Length	Stroke	A	B	C	Load capacity for a pair of rails	Weight per single guide
		[mm]	[mm]	[mm]	[mm]	[mm]	C_{Orad} [N]	[kg]
LFS	58	400	434	128	128	224	400	1.10
		450	484	160	160	256	500	1.25
		500	534			192	320	550
		550	584	600	1.55			

Tab. 4

Note: The given load capacities are guidelines with 100,000 cycles and uniform load distribution (area load) when using all mounting holes. The load values must be reduced in unfavorable conditions. Horizontal installation is not possible due to the damping system. The damping effect is reduced for loads of 450 N and higher per extension pair.

> LFS 70

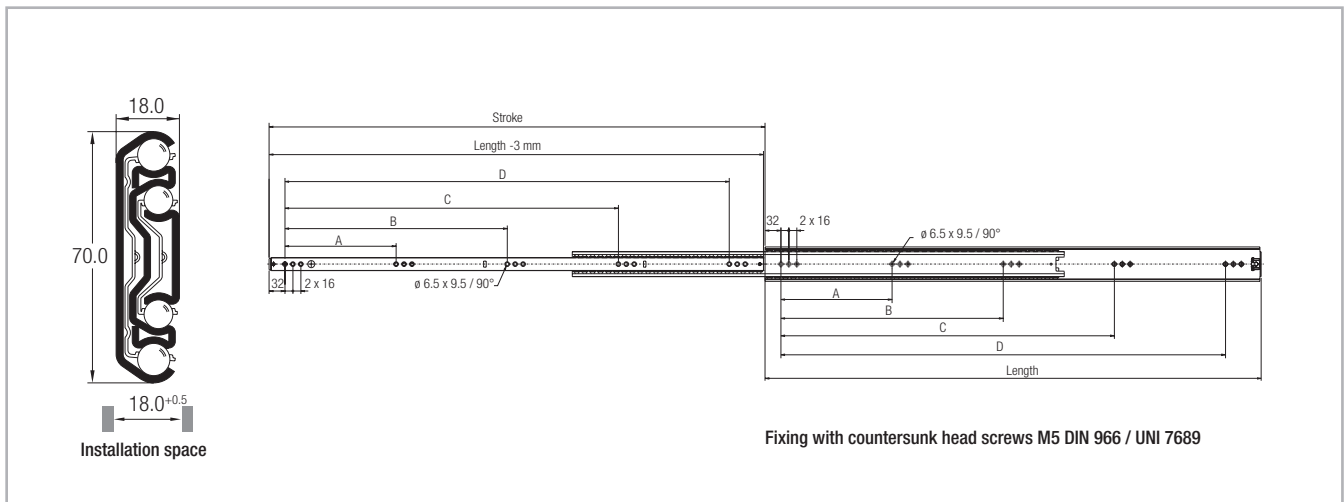

All dimensions given in mm

Fig. 19

Type	Size	Length	Stroke	A	B	C	D	Load capacity for a pair of rails		Weight per single guide	
		[mm]	[mm]	[mm]	[mm]	[mm]	[mm]	C_{Orad} [N]	C_{Oax} [N]		
LFS	70	400	400	-	-	-	288	1050	1800*	300	1,55
		450	450	-	-	160	320	1150	1900*		1,74
		500	500	-	-	192	384	1300	1950*		1,94
		550	550	-	-	224	448		2000*		2,13
		600	600	-	-				1950*		2,32
		700	700	-	192	384	576	1750*	2,70		
		800	800	-	224	448	672	1200	1450*		3,10
		1100	1100	224	448	672	896	900	1050*	200	4,25

* 10.000 cycles

Tab. 5

Note: The given load capacities are guidelines with 100.000 cycles and uniform load distribution (area load) when using all mounting holes. The load values must be reduced in unfavorable conditions.

> LFX 27

Stainless steel telescopic guide

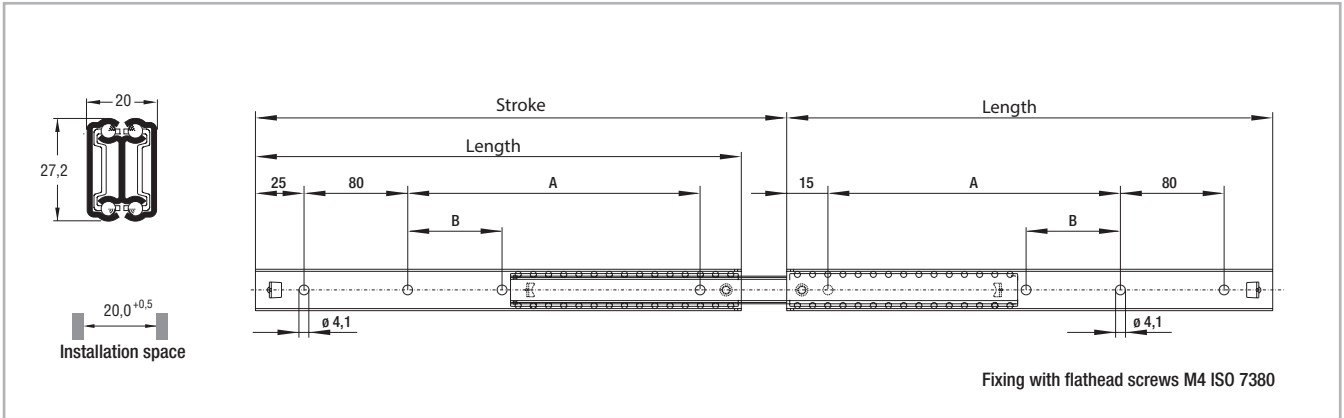

Fig. 20

Type	Size	Length [mm]	Stroke [mm]	A [mm]	B [mm]	Load capacity for a pair of rails [N]				Weight per single guide [kg]
						to 10.000 cycles		to 100.000 cycles		
						C_{Orad}	C_{Oax}	C_{Orad}	C_{Oax}	
LFX	27	300	326	180	-	350	50	250	50	0,43
		350	376	230	70					0,49
		400	426	280	100					0,57
		450	476	330	100					0,64
		500	526	380	140					0,72
		550	576	430	160					0,76

Tab. 6

> Fixing screws

We recommend fixing screws according to ISO 7380 with low head height or TORX® screws (see fig. 21) on request.

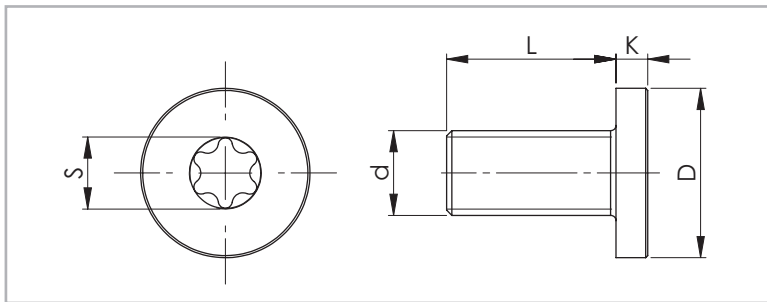

Fig. 21

Rail size	Screw type	d	D [mm]	L [mm]	K [mm]	S	Tightening torque [Nm]
30	M5 x 10	M5 x 0.8	10	10	2	T25	9

Tab. 7

Technical instructions

> Load capacities

Vertical installation (radial load)

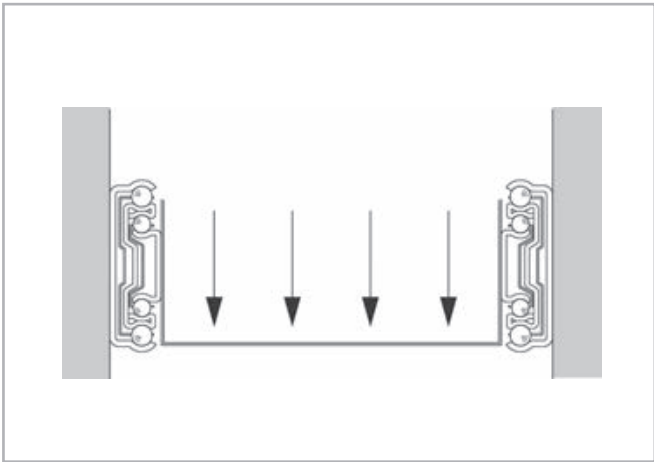

Fig. 22

The given loading capacities are guidelines for a pair of rails vertically mounted with uniform load distribution using all mounting holes. The load values must be reduced in unfavorable conditions.

Horizontal installation (axial load)

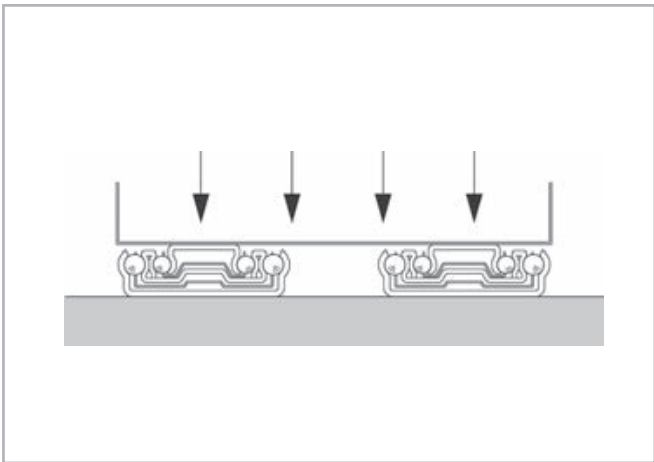

Fig. 23

For horizontal mounted extensions the load capacity is reduced (see pg. LR-6ff).

> Speed

The extension speed is determined by the size of the intermediate elements. Therefore, the maximum extension speed is inversely proportional to the overall extension of the rails (see fig. 24). The maximum extension speed is also directly related to the applied load and operating time. The indicated data refers to continuous operation at the maximum load capacity.

> Temperature

Continual operating temperature of the Light Rail extensions is +10 °C to +40 °C. Temporary storage and transport temperature: -20 °C to max. +80 °C.

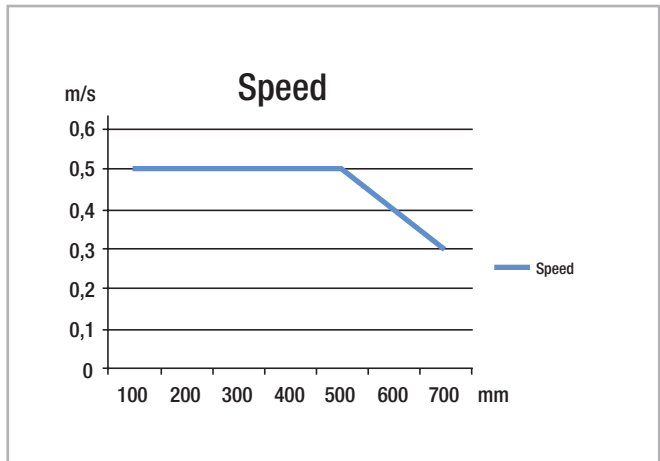

Fig. 24

> Lubrication

All extensions of the Light Rail product family are lubricated for life. Different lubricants for special applications are available upon request. Example: Lubricant with FDA approval for use in the food industry. For more information please contact Rollon technical support.

> Corrosion protection

Base material for the Light Rail product family is cold-rolled, hot-dipped galvanized steel. The cathodic edge protection offers a perfect combination of quality and cost-efficiency. The surface protection conforms to RoHS. For more information please contact Rollon technical support.

> Installation instructions

- The existing internal stops are not designed to stop the moving load. They are only supposed to retain the ball-cage and prevent the internal parts to slide out of the assembly. An external end-stop must always be installed to stop the moving load.
- To achieve optimum running properties, high service life and rigidity, it is necessary to fix the Light Rail extensions with all accessible holes on a rigid and level surface. Please observe the parallelism of the installation surfaces. The fixed and movable rails fit to the rigid assembly construction.
- Light Rail full and partial extensions are suitable for use in automatic systems. For this, the stroke should remain constant in all moving cycles and the extension speed must be checked (see pg. LR-14, fig.24). The movement of the extensions is enabled by internal ball cages, which could experience an offset from the original position with differing strokes. This phase offset can have a negative effect on the running properties or limit the stroke. If differing strokes occur in an application, the drive force must be sufficiently dimensioned in order to appropriately synchronize the ball cage offset. As an alternative, an extra full stroke cycle can be performed every certain number of cycles, in order to re-phase the ball cage in its correct position.

Horizontally installed guides

Horizontally intalled exstions can support tension or compression loads (see figs. 25 and 26).

For the horizontal mounting of extensions with compression loads, please take the following conditions into account: The Hertzian stress of the balls in no longer effective due to the expansion of the rail profile; the nominal tension tolerance of +0.5 mm is eliminated due to the installation configuration. Both the above mentioned conditions contribute to a significant reduction of the axial load capacity.

Horizontally-mounted rails (axial load) also determine a considerably higher deflection of the extended tips if compared to traditionally vertically-mounted rails (radial load).

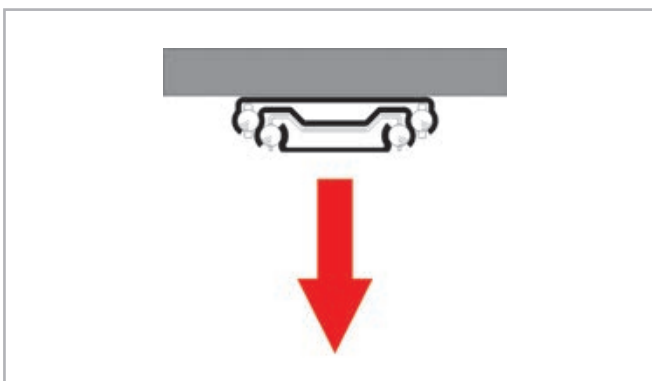

Fig. 25

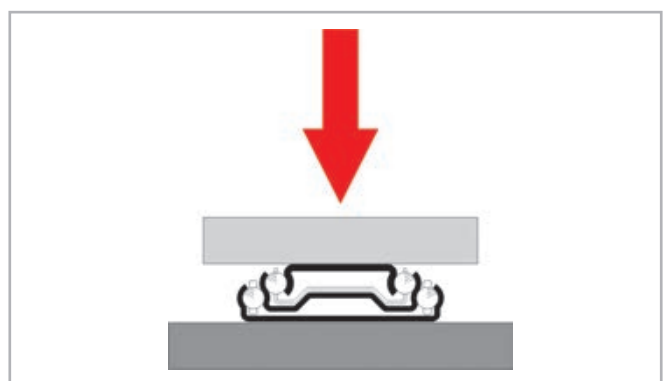

Fig. 26

Ordering key

> Light Rail

LFS	58-	400	SC	
			Automatic retraction only in LFS 58 SC	<i>see pg. LR-9</i>
		Rail length in mm	<i>see pg. LR-6</i>	
	Size	<i>see pg. LR-6</i>		
Rail type	<i>see pg. LR-6</i>			

Ordering example: LFS58-0400SC

Notes on ordering: The rail lengths are always indicated as 4 digits with 0 prefixes

Guides suitable for all applications



Railway

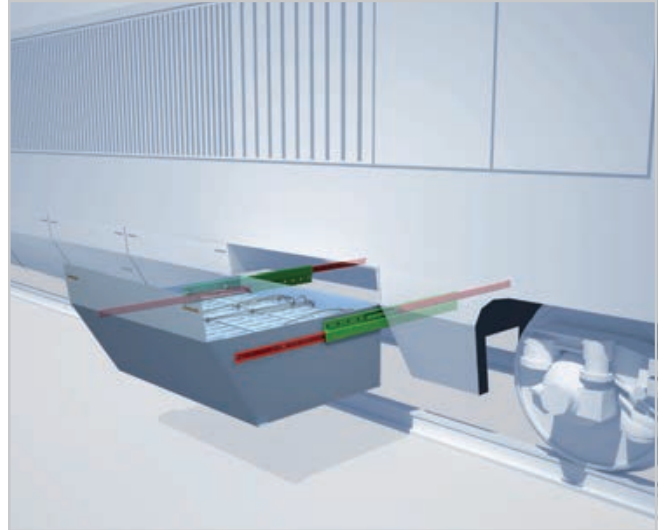
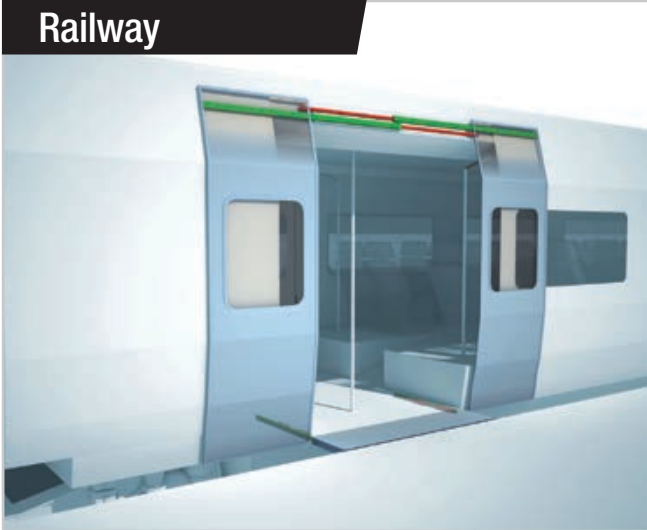

Medical

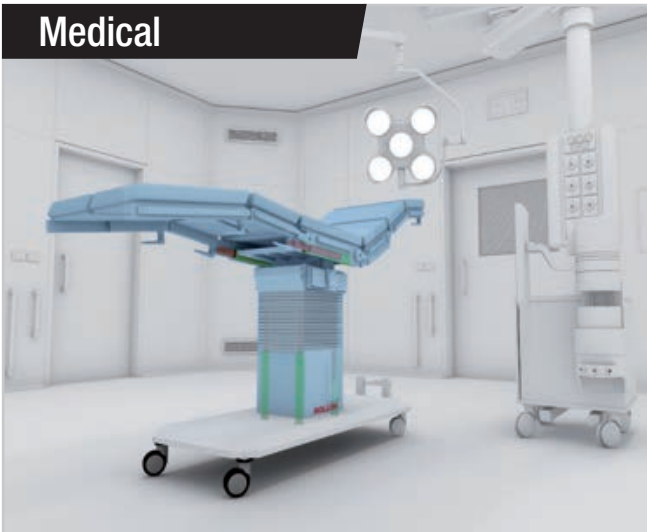

Logistics

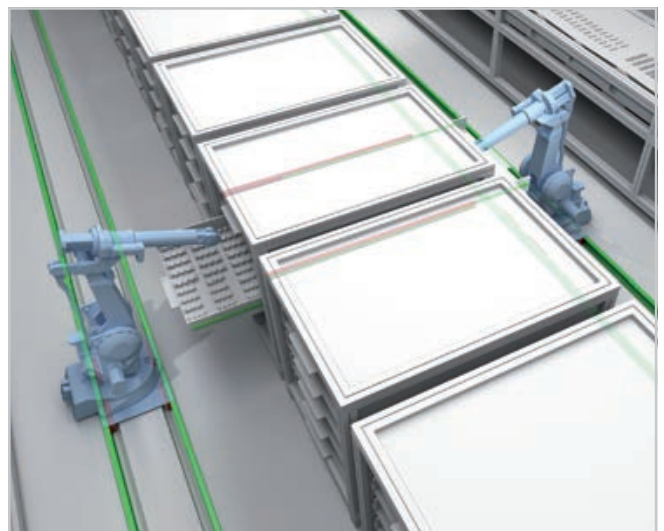

Aerospace



Special Vehicles



Industrial

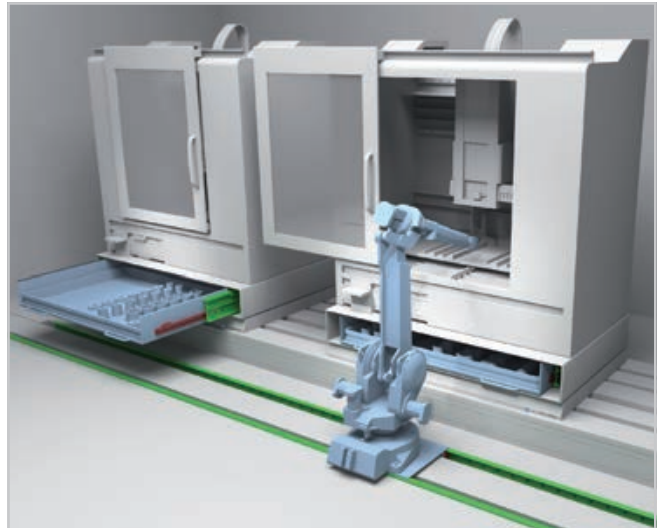



Follow us:



● Rollon Branches & Rep. Offices
● Distributors

EUROPE

ROLLON S.p.A. - ITALY (Headquarters) ▼

Via Trieste 26
I-20871 Vimercate (MB)
Phone: (+39) 039 62 59 1
www.rollon.it - infocom@rollon.it

ROLLON GmbH - GERMANY ▼

Bonner Strasse 317-319
D-40589 Düsseldorf
Phone: (+49) 211 95 747 0
www.rollon.de - info@rollon.de

ROLLON S.A.R.L. - FRANCE ▼

Les Jardins d'Eole, 2 allée des Séquoias
F-69760 Limonest
Phone: (+33) (0) 4 74 71 93 30
www.rollon.fr - infocom@rollon.fr

ROLLON B.V. - NETHERLANDS ▼

Ringbaan Zuid 8
6905 DB Zevenaar
Phone: (+31) 316 581 999
www.rollon.nl - info@rollon.nl

ROLLON S.p.A. - RUSSIA (Rep. Office) ▼

117105, Moscow, Varshavskoye
shosse 17, building 1
Phone: +7 (495) 508-10-70
www.rollon.ru - info@rollon.ru

ROLLON Ltd - UK (Rep. Office) ▼

The Works 6 West Street Olney
Buckinghamshire, United Kingdom, MK46 5 HR
Phone: +44 (0) 1234964024
www.rollon.uk.com - info@rollon.uk.com

AMERICA

ROLLON Corporation - USA ▼

101 Bilby Road. Suite B
Hackettstown, NJ 07840
Phone: (+1) 973 300 5492
www.rolloncorp.com - info@rolloncorp.com

ROLLON - SOUTH AMERICA (Rep. Office) ▼

R. Joaquim Floriano, 397, 2o. andar
Itaim Bibi - 04534-011, São Paulo, BRASIL
Phone: +55 (11) 3198 3645
www.rollonbrasil.com.br - info@rollonbrasil.com

ASIA

ROLLON Ltd - CHINA ▼

No. 1155 Pang Jin Road,
China, Suzhou, 215200
Phone: +86 0512 6392 1625
www.rollon.cn.com - info@rollon.cn.com

ROLLON India Pvt. Ltd. - INDIA ▼

1st floor, Regus Gem Business Centre, 26/1
Hosur Road, Bommanahalli, Bangalore 560068
Phone: (+91) 80 67027066
www.rollonindia.in - info@rollonindia.in

ROLLON - JAPAN ▼

3F Shiodome Building, 1-2-20 Kaigan, Minato-ku,
Tokyo 105-0022 Japan
Phone +81 3 6721 8487
www.rollon.jp - info@rollon.jp

Consult the other ranges of products



Distributor

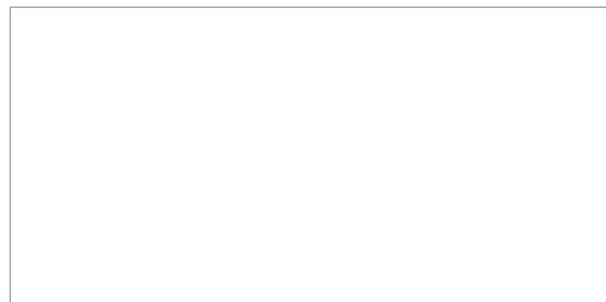

All addresses of our global sales partners can also be found at www.rollon.com

The content of this document and its use are subject to the general terms of sale of ROLLON available on the web site www.rollon.com.
Changes and errors expected. The text and images may be used only with our permission.