

Vacuum Clamping Systems
Matrix-Plate for Metalworking

Vacuum Clamping System Matrix-Plate

The efficient and universal clamping system

Clamping with short set-up times, high holding forces and excellent precision

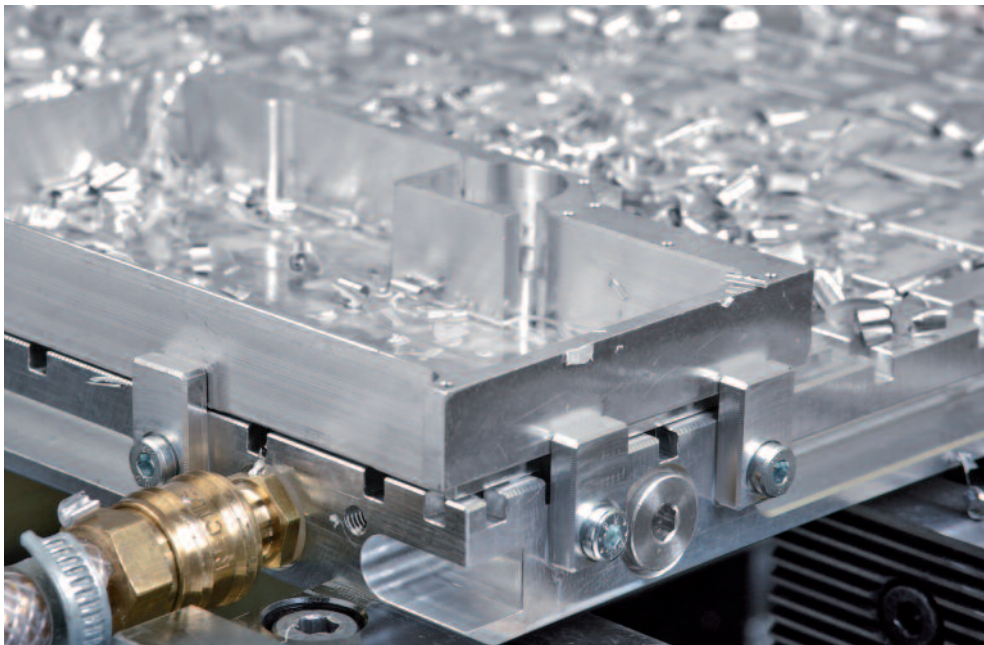

The Matrix-Plate is particularly suitable for process-safe clamping of large, flat metal workpieces with smooth bottom surfaces on CNC machining centres and guarantees very short set-up times. Even components which are difficult to clamp mechanically can be clamped easily, quickly, without distortion and precisely.

The Matrix-Plate can be secured quickly on the machine table with the aid of clamping claws or a zero-point clamping system. The modular design ensures maximum flexibility, since the components are easy to handle and the various versions can be combined freely. The complexity of the workpiece geometry, the type of machining and the horizontal forces which have to be handled determine which version of the Matrix-Plate should be used.

Flexible layout of a complete vacuum clamping system

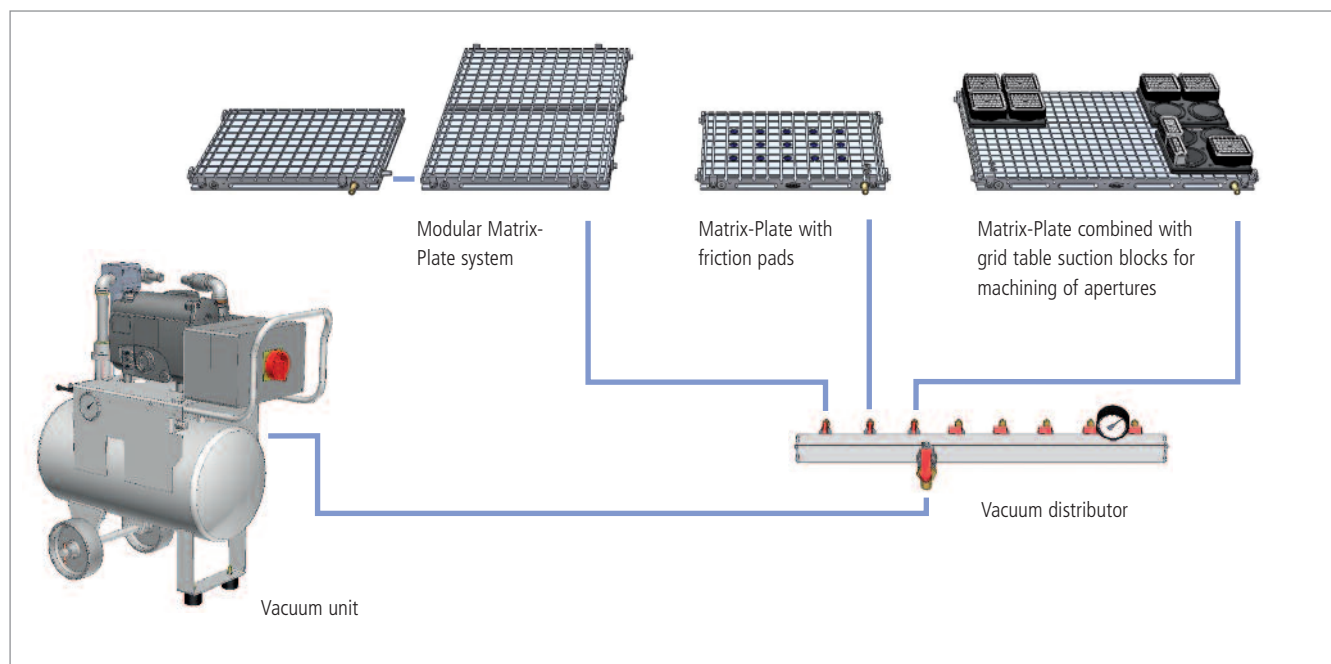

Vacuum Clamping System Matrix-Plate

The efficient and universal clamping system

Unique friction pads permit 30% higher horizontal forces

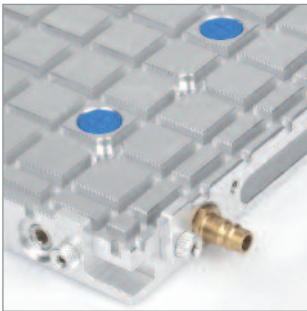

Matrix-Plate with friction pads

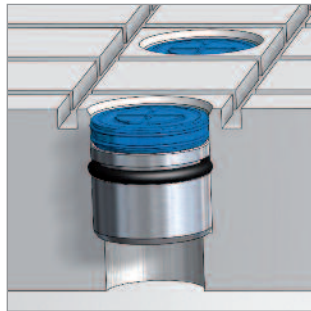

Friction pads inactive

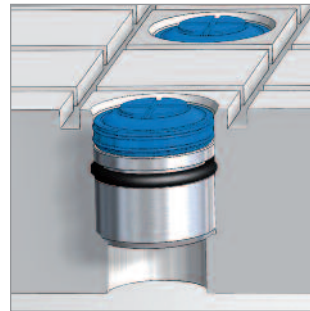

Friction pads active

Exclusive Schmalz feature: optional friction pads permit the Matrix-Plate to withstand much higher horizontal forces

- High horizontal holding forces (up to about 30% higher than a Matrix-Plate without friction pads)
- Friction pads generate no additional forces on the workpiece
- Oil- and ozone-resistant; pads can be replaced individually when worn
- Automatic activation and deactivation when vacuum is switched on and off

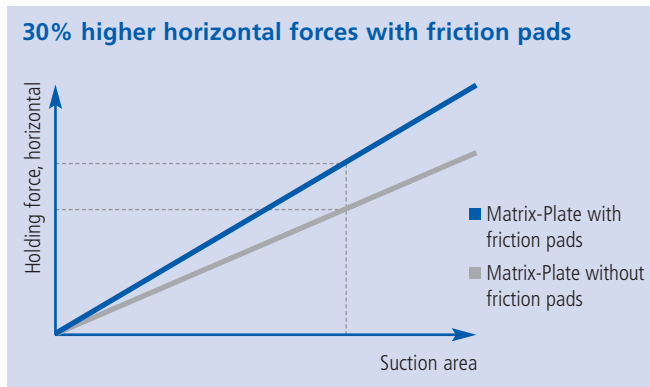

Practical example*

Workpiece material	Steel S235	Alu EN-AW 2007
Workpiece dimensions	200 x 240 mm	200 x 240 mm
Effective suction area	ca. 350 cm ²	ca. 350 cm ²
Holding force, vertical, calculated	2.8 kN	2.8 kN
Holding force, horizontal, measured		
- without friction pads, ca.	400 N	390 N
- with friction pads, ca.	510 N	480 N

The data shown here were determined experimentally and should be understood as typical approximate values. For each application, the holding forces must be tested under realistic conditions.

*Lubricated with drilling emulsion (8% oil), differential pressure -800 mbar

Safe clamping of even complex workpieces

For machining of simple workpieces, widely spaced slots are sufficient. Complex workpieces with holes or apertures must be additionally sealed around their edges with sealing rubber in order to maintain the vacuum. If a plate with closely spaced slots is used, this sealing rubber can be positioned close to the edges of the apertures and holes. This ensures flexible sealing and minimises the loss of clamping forces.

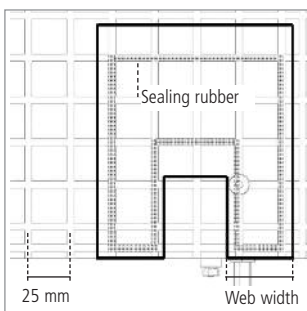

Simple workpiece

- Simple geometrical structure
- Few webs and apertures
- Web width > 30 mm

Recommendation: slot spacing 25 x 25 mm

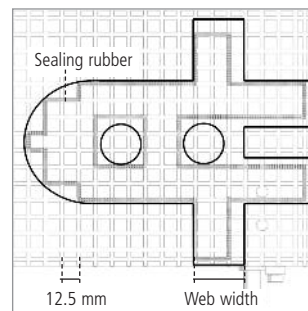

Complex workpiece

- Complex geometrical structure
- Many webs and apertures
- Web width < 30 mm

Recommendation: slot spacing 12.5 x 12.5 mm

Vacuum Clamping System Matrix-Plate

The right solution for every task

Applications

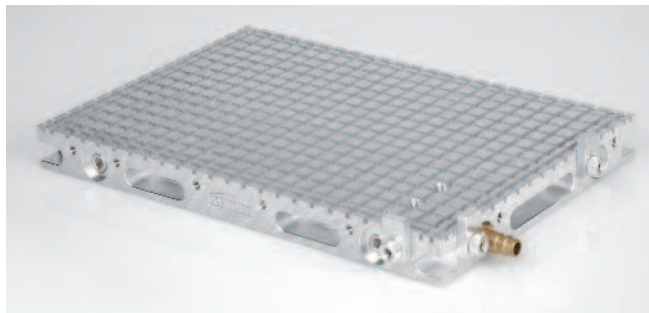

Matrix-Plate without friction pads

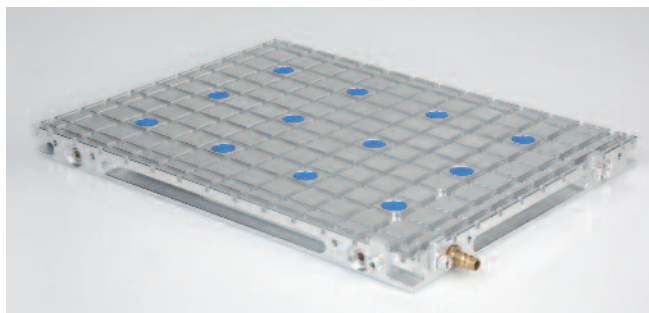

Matrix-Plate with friction pads

- Vacuum clamping system Matrix-Plate for distortion-free clamping of large, flat workpieces
- Body made of high-strength aluminium
- Modular design permits extension to increase the effective suction area
- High precision (height tolerance +/- 0.02 mm)
- Short set-up times; easy to handle
- Mechanical stops as positioning aids and to accommodate additional horizontal forces
- High degree of flexibility due to modular design
- Simple machining of apertures by combining the Matrix-Plate with grid table suction blocks from Schmalz
- High horizontal holding forces (up to 30% higher) with optional friction pads
- Friction pads activated and deactivated automatically when the vacuum is switched on and off

Ordering data, Matrix-Plate MPL-300x200x28

Type	Dimensions	Slot spacing	Slot dimensions	Article No.
MPL-300x200x28-12,5-3	300 x 200 x 28 mm	12.5 x 12.5 mm	3 x 3 mm	10.01.27.00100
MPL-300x200x28-25-3	300 x 200 x 28 mm	25 x 25 mm	3 x 3 mm	10.01.27.00101
MPL-300x200x28-25-3-R	300 x 200 x 28 mm	25 x 25 mm	3 x 3 mm	10.01.27.00102

Delivered complete with stops, hose nozzle, sealing plug and sealing rubber. MPL-...-R-Variant complete with friction pads

Ordering data, Matrix-Plate MPL-400x300x28

Type	Dimensions	Slot spacing	Slot dimensions	Article No.
MPL-300x400x28-12,5-3	400 x 300 x 28 mm	12.5 x 12.5 mm	3 x 3 mm	10.01.27.00103
MPL-300x400x28-25-3	400 x 300 x 28 mm	25 x 25 mm	3 x 3 mm	10.01.27.00104
MPL-300x400x28-25-3-R	400 x 300 x 28 mm	25 x 25 mm	3 x 3 mm	10.01.27.00106
MPL-300x400x28-30-5	400 x 300 x 28 mm	30 x 30 mm	5 x 5 mm	10.01.27.00105
MPL-300x400x28-30-5-R	400 x 300 x 28 mm	30 x 30 mm	5 x 5 mm	10.01.27.00107

Delivered complete with stops, hose nozzle, sealing plug and sealing rubber. MPL-...-R-Variant complete with friction pads

Also available with slot dimensions 5 x 5 mm for combination of the Matrix-Plate with Schmalz grid table suction blocks for machining of apertures.

Ordering data, Matrix-Plate MPL-600x400x28

Type	Dimensions	Slot spacing	Slot dimensions	Article No.
MPL-400x600x28-12,5-3	600 x 400 x 28 mm	12.5 x 12.5 mm	3 x 3 mm	10.01.27.00108
MPL-400x600x28-25-3	600 x 400 x 28 mm	25 x 25 mm	3 x 3 mm	10.01.27.00109
MPL-400x600x28-25-3-R	600 x 400 x 28 mm	25 x 25 mm	3 x 3 mm	10.01.27.00111
MPL-400x600x28-30-5*	600 x 400 x 28 mm	30 x 30 mm	5 x 5 mm	10.01.27.00110
MPL-400x600x28-30-5-R*	600 x 400 x 28 mm	30 x 30 mm	5 x 5 mm	10.01.27.00112

Delivered complete with stops, hose nozzle, sealing plug and sealing rubber. MPL-...-R-Variant complete with friction pads

Also available with slot dimensions 5 x 5 mm for combination of the Matrix-Plate with Schmalz grid table suction blocks.

4 *For this version two vacuum connectors are needed for combining with the grid table suction blocks. See page 6 for vacuum distributors.

Vacuum unit

Flexible and safe vacuum generation

Powerful system component incorporating Schmalz know-how

In order to safely clamp workpieces with vacuum, a powerful vacuum unit designed specifically to meet the requirements of the application is needed in addition to the Matrix-Plate. Vacuum units from Schmalz complete the Matrix-Plate clamping system and guarantee maximum flexibility and a high level of safety.

Schmalz's know-how and many years of experience in vacuum technology ensure that the customer receives the best combination of high-quality components. Schmalz vacuum units are equipped with an oil-lubricated vacuum pump and a liquids trap which also acts as a vacuum reservoir. Various components for system monitoring and interfaces for integration into the control system of the CNC machining centre guarantee safe operation.



Construction

- Emergency-off function to prevent damage to the pump if liquids are drawn in
- Monitoring of the vacuum level
- Visible and audible warning device
- Visual monitoring of the liquid level in the reservoir
- Integrated energy-saving function
- Vacuum boost for higher and permanent operating vacuum without automatic deactivation
- All safety warnings can be integrated in the machine control
- Manual valves for draining off the liquids and for switching off the vacuum inlet
- Vacuum generator with higher level of automation available on request

Selection of the appropriate vacuum unit

Clamping area	Recommended suction capacity	Vacuum unit
< 1,200 cm ²	6 m ³ /h	VAGG 6 AC3 10
< 5,000 cm ²	18 m ³ /h	VAGG 18 AC3 30
< 1 m ²	40 m ³ /h	VAGG 40 AC3 80
< 2 m ²	63 m ³ /h	VAGG 63 AC3 80

Important system-configuration note:

A complete system consists of a Matrix-Plate and a vacuum unit. The vacuum unit from Schmalz includes, in addition to the functions vacuum on/off and level monitoring, system monitoring with the aid of an integrated vacuum switch. Which can be synchronised with the controller of the machining centre via a special interface. This makes it possible to automatically stop the machining operation if the clamping force drops below a predefined level.*

*In accordance with BGI5003, Section. 2.5.2.7

Vacuum unit, accessories and spare parts

The complete solution for vacuum generation

Ordering data, vacuum unit VAGG

Type	Article No.
VAGG 6 AC3 10	10.01.27.00120
VAGG 18 AC3 30	10.01.27.00121
VAGG 40 AC3 80	10.01.27.00122
VAGG 63 AC3 80	10.01.27.00123

Design data, vacuum unit VAGG

Type	L [mm]	B [mm]	H [mm]	Reservoir volume [l]
VAGG 6 AC3 10	700	335	700	10
VAGG 18 AC3 30	742	360	767	30
VAGG 40 AC3 80	1,016	435	927	80
VAGG 63 AC3 80	1,016	480	1,000	80

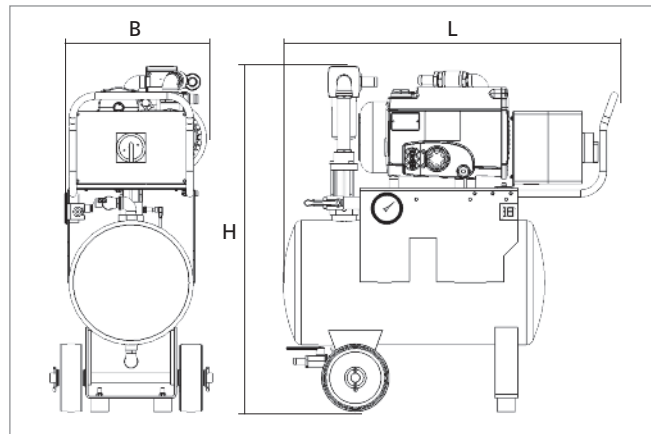

Vacuum unit VAGG

Technical data, vacuum unit VAGG

Type	Max. vacuum [mbar]	Suction capacity at 50 Hz [m³/h]	Supply voltage at 50 Hz [V]	Current range 50 Hz [A]	Rated power at 50 Hz [kW]	Noise level at 50 Hz [db/A]	Weight [kg]
VAGG 6 AC3 10	-980	6	175–260 / 300–450	1.9 / 1.1	0.25	48	30
VAGG 18 AC3 30	-980	18	190–260 / 300–450	3.3 / 1.95	0.55	63	48
VAGG 40 AC3 80	-980	40	200–240 / 345–420	4.8 / 2.8	1.10	64	85
VAGG 63 AC3 80	-980	63	200–240 / 345–420	6.2 / 3.6	1.50	65	100

Ordering data, spare parts and accessories

Type	Article No.
Sealing rubber 3 mm DI-SCHN-CR20 3	10.07.04.00088
Sealing rubber 3.5 mm DI-SCHN-CR20 3,5	10.07.04.00091
Sealing rubber 5 mm DI-SCHN-CR20 5	10.07.04.00094
Sealing rubber 5.5 mm DI-SCHN-CR20 5,5	10.07.04.00095
Clamping claw SPAN-PRA-M12	10.01.27.00009
Stop ANSG-MPL (with set screw and knurled nut)	10.01.27.00079
Friction pad REIB-IN	10.01.27.00060
Vacuum hose VSL 21-12 PVC-G	10.07.09.00006
Vacuum hose VSL 34-25 PVC-DS	10.07.09.00041
Hose clamp SSB 16-27	10.07.10.00002
Hose clamp SSB 20-32	10.07.10.00003
Hose nozzle ST G1/4-AG 12	10.08.03.00158
Hose nozzle ST G3/4-AG 12	10.08.03.00164
Hose nozzle ST G3/4-AG 25	10.08.03.00166
Distributor VTR G3/4-IG 8xG1/4	10.01.27.00126

Further accessories and spare parts available on request

Practical application examples

Vacuum clamping system Matrix-Plate for metalworking

Clamping device for the aerospace industry

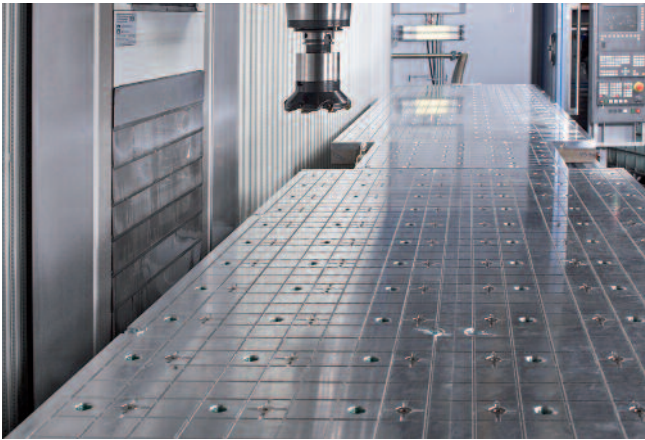

A specially developed combination of mechanical clamping elements and vacuum clamping devices

The often very complex geometry of parts used in the aerospace industry frequently require the use of clamping solutions matched specifically to the application. Maximum precision and careful handling of the workpieces are also very important.

Schmalz has already developed special solutions for many customer-specific projects. With the Matrix-Plate, it is possible to clamp even very thin workpieces securely without damaging them. Further arguments in favour of vacuum clamping systems are the reduced set-up times and the high level of flexibility.

Efficient clamping of aluminium cubes

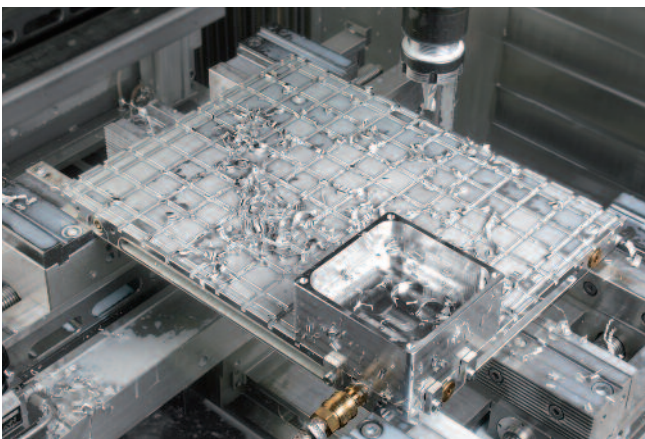

Vacuum clamping system Matrix-Plate on a CNC machining centre

This application shows a Matrix-Plate in use on a CNC machining centre. It is secured to the machine table with the aid of mechanical clamping elements. The use of vacuum makes it possible to clamp the thin bases of the workpieces precisely and without distortion for five-axis machining without repositioning.

The vacuum is generated by the powerful vacuum unit VAGG from Schmalz. The compact design makes it suitable for mobile use. It has castors and a handle by which it can be moved flexibly to the desired position.

Milling holes in a workpiece with a Matrix-Plate and suction blocks

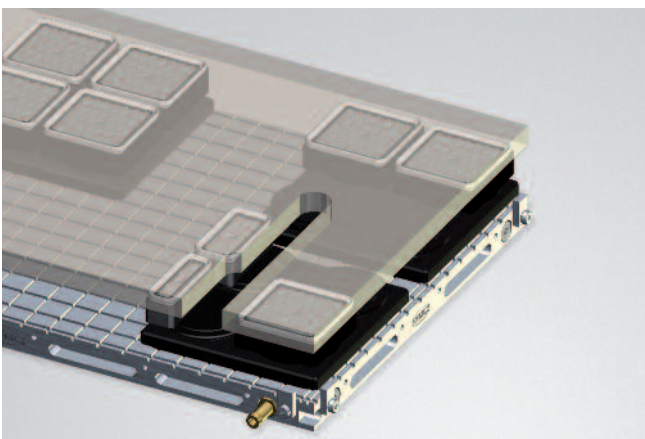

Use of grid table suction blocks for milling holes through a workpiece

The use of grid table suction blocks makes it possible to machine holes and apertures in workpieces. For this, the workpiece is clamped on a Matrix-Plate with very low height tolerances for the first machining step.

For the second step, the grid table suction blocks are placed directly in the slots of the Matrix-Plate and the suction blocks are positioned to match the positions of the holes. The holes can now be drilled through the workpiece without damaging the Matrix-Plate or the actual workpiece.



Vacuum Components

Innovative vacuum components from Schmalz offer many users in various sectors of industry reliable support in the solution of automation and handling tasks. The wide range of components extends from suction pads and vacuum generators to mounting elements and system monitoring devices.

Tel. +49 (0)7443 2403 102
Fax +49 (0)7443 2403 597



Vacuum Gripping Systems

Complex vacuum gripping systems from Schmalz permit decisive productivity improvements to be achieved. The range extends from layer and large-area gripping systems to complete vacuum spiders, delivered ready for connection, for use in all areas of automation.

Tel. +49 (0)7443 2403 107
Fax +49 (0)7443 2403 596



Vacuum Handling Systems

Ergonomical vacuum lifting devices Jumbo and VacuMaster for effortless, damage-free handling of workpieces. Crane systems to supplement these to form complete system solutions which are precisely matched to the planned application. Workshop equipment as practical aids in trade and industry.

Tel. +49 (0)7443 2403 108
Fax +49 (0)7443 2403 399



Vacuum Clamping Systems

Future-oriented vacuum clamping technology from Schmalz is the intelligent response to the continually increasing demands for more productivity and economic operation of CNC machine tools.

Tel. +49 (0)7443 2403 109
Fax +49 (0)7443 2403 595