

MEGAPOWER



MEGADYNE

Introduction to Megapower belts	2
Megapower belt system specifications	3
Classifications	4
Power transmission calculation procedure	6
Calculation parameters	8
Belt calculation example	9
Belt installation	10
Causes of belt failure	11
Belt data	
MXL	12
XL	13
L	14
H	15
T2,5	16
MEGAPOWER 2 T5 - T5DL	17
MEGAPOWER 2 T10 - T10DL	18
MEGAPOWER 2 AT5	19
MEGAPOWER 2 AT10	20
FC (food contact)	21
Megapower feasibility table	22
Coatings and cover properties	23
Special executions	24
Special executions photos	25
Pulleys and timing bars	27
Useful formulas and conversion table	29
Data sheets	31

INTRODUCTION TO MEGAPOWER BELTS

MEGADYNE began manufacturing transmission belts in 1957 and moulding MEGAPOWER belts in 1975. MEGAPOWER timing belts are manufactured in thermoset polyurethane by a unique moulding process. The thermoset polyurethane gives superior wear and abrasion resistance. Several type of cords, helically wound rolled up inside the belts, assure excellent dimensional stability and offer high performances in terms of flexibility and traction resistance. MEGAPOWER belts are particularly suitable for power transmission applications.

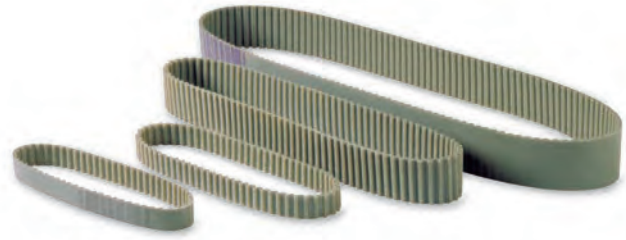

MEGAPOWER USE ADVANTAGES

MEGAPOWER timing belt drives represent a modern and efficient system of power transmission. They combine the advantages and properties of geared drives with those of Vee and Flat belts whilst eliminating the troubles typical of each of these types of transmission.

MEGAPOWER drives allow:

- synchronous transmission
- constant and high angular speed
- excellent mechanical performance
- dimensional stability
- low noise
- low installation tension
- minimum drive dimensions
- omega drive configuration
- customised belt engineering

MEGAPOWER APPLICATION AREAS

Thanks to their features, Megapower belts can be successfully used in a wide range of applications such as:

- computers tape movement
- office automation equipment
- medical equipment
- packaging machinery
- motor vehicles
- swimming pool cleaning robots
- plotters
- money changers
- optical instruments
- robotic arms
- electric appliances
- shower manual controls
- vacuum systems
- vending machines
- food machinery
- textile machinery
- leisure and do-it-yourself equipment

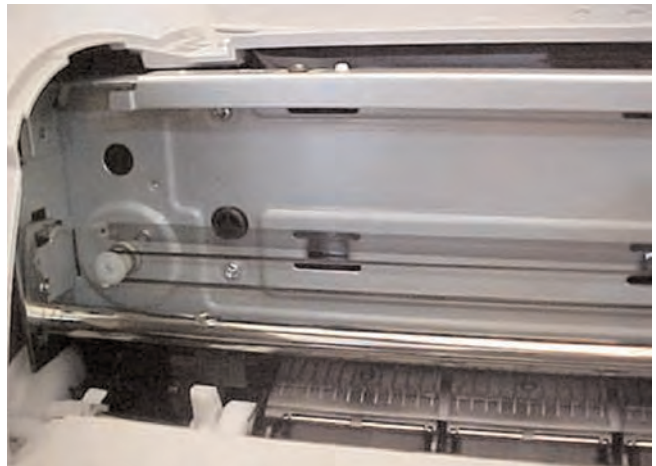
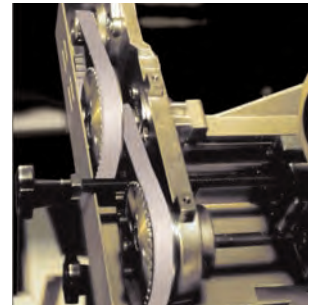
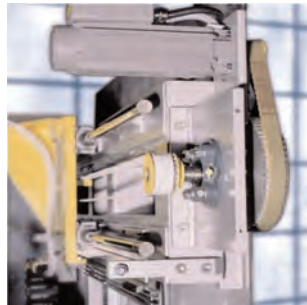

MEGAPOWER BELT SYSTEM SPECIFICATIONS

To satisfy a wide range of loads, speeds and applications, MEGAPOWER belts and pulleys are made in a selection of sizes, capacities and dimensions.

The three most significant dimensions of a belt are:

1) Pitch is the distance in millimetres between two adjacent teeth centers as measured on the pitch line of the belt; the theoretical pitch line of a MEGAPOWER belt lies within the tensile member.

It is indicated with abbreviations like T5, AT5, T10, AT10, H. The correspondence between abbreviations and pitches are indicated in the products pages.

2) Pitch length is the total length (circumference) in millimetres as measured along the pitch line.

On the pulley, the pitch line identifies the primitive diameter.

The primitive diameters of the driver (d_1) and driven (d_2) pulleys are the ones to be used for calculating the transmission ratio

$$i = \frac{d_2}{d_1}$$

3) Width can vary depending on driving system needs.

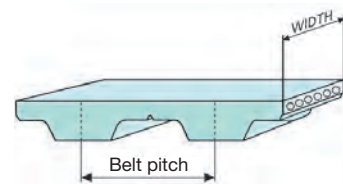
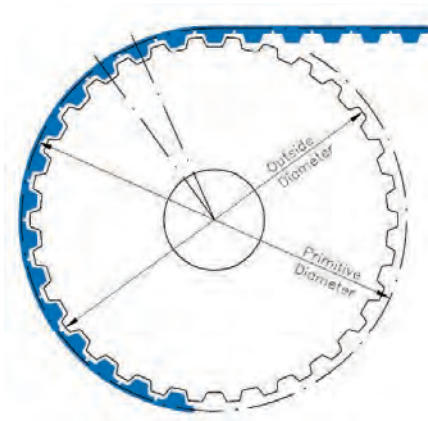

Reference dimensions

The imperial pitch belts tooth profile follow ISO 5296-1 normative.

The T and AT series tooth profile follow the normative ISO 17396.

A belt is constituted by two components: the body in POLYURETHANE and a tension member represented by the CORDS in steel, fiberglass, polyester and Kevlar.

STANDARD RANGE

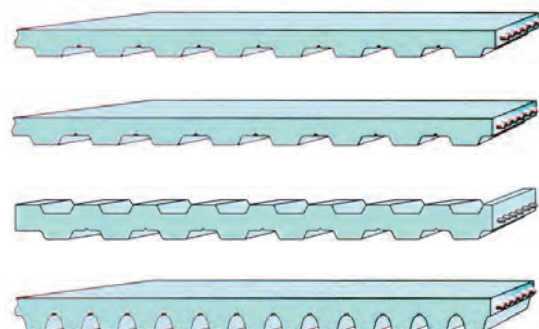

MEGAPOWER: MXL • XL • L • H

MEGAPOWER: T2,5 •
MEGAPOWER2: T5 • T10

MEGAPOWER2: T5DL • T10DL

MEGAPOWER2: AT5 • AT10

CLASSIFICATIONS

CLASSIFICATIONS

Megapower Timing Belts are manufactured in thermoset polyurethane, with helically wound zinked steel. This type of belts, developed by our Research & Development, offers good running characteristics and high traction loads. They are especially suited for power transmission. An extra thickness of special coating is also possible on the back of the belt offering extra protection against aggressive or heavy products.

1. The body of the belts is grey/green thermoset polyurethane 88 ShA, characterized by high levels of wear resistance even in the presence of shock and surge loading. The thermoset polyurethane is obtained by mixing a prepolymer with a bonding compound and heating the mixture. After cooling down to ambient temperature, the result is a polyurethane with good chemical and mechanical characteristics giving the belt high performances and long lifetime.
2. High strength helically wound zinked steel tension members allow high breaking load and extremely low elongation.

The combination of these high grade materials improves belt performances which can be summarised as follows:

- exceptional resistance to abrasion and tooth shear
- low coefficient of friction
- high flexibility
- ozone and temperature resistance (-25 °C / +80 °C)
- oil, grease and gasoline resistance

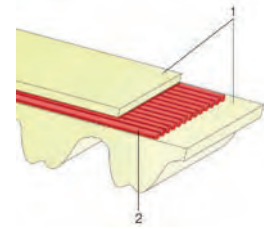

MECHANICAL AND CHEMICAL CHARACTERISTICS

- Constant dimensions
- Noiseless
- Free maintenance
- High flexibility
- High resistance steel traction cords, with little stretching and top flexibility
- Linear speeds up to 30 m/s
- Low pretension
- Constant length
- High abrasion resistance
- Ageing, Hydrolysis, Ozone resistant
- Working temperature -25 °C / +80 °C
- High resistance to Oils, Greases and Gasoline
- Fairly Acid-proof and Alkali-proof

Body

Megapower belts are manufactured with grey/green thermoset polyurethane 88 ShA as standard.

Special compounds (different hardnesses, special properties) are available on request. Here under some PU characteristics:

- Water** No problem in normal or sea clean water, at room temperature. Over 60 °C there is a fast decrease of breaking strength.
- Acids** In acids diluted proportions, at room temperature, this PU is moderately attacked. In high concentration acid solutions, this PU has a very short lifespan. Over 50 °C, acids are always dangerous for thermoset PU.
- Alkalis** In alkalis diluted proportions, at room temperature, this PU is moderately attacked. In high concentration alkaline solutions, this PU has a very short lifespan.
- Solvents** Thermoset PU is insoluble in the greater part of solvents. Only the very polar solvents (same as tetrahydrofuran, dimethylformamide, n-methylpyrrolidone) can dissolve or tight damage PU. The esters or the ketons (same as ethylacetate or methylethylketene) can usually produce a bulge, decreasing mechanical characteristics. The aromatic hydrocarbons and the aliphatic hydrocarbons produce very high bulge.
- Oils** PU has a high resistance to mineral pure oils (lubricants, engine oils, combustible oils). Usually, high performance syntetic oils, due to special additives contained, can be incompatible with thermoset PU, especially at high temperature.
- Greases** PU has a high resistance to pure mineral greases (lubricants greases). Usually, high performance syntetic greases, due to special additives contained, can be incompatible with thermoset PU, especially at high temperature.
- Fuels** Good resistance to petrol without alcohols. In presence of alcohols, thermoset PU can suffer deterioration. Fuels including aromatic stuffs can produce reversible bulges.
- Microorganisms** In presence of grime, containing humidity, microorganisms can develop. In case that microbic attack can produce danger, you have to use a special kind of PU.

CORDS

Standard cord	Megapower is manufactured with helicoidal zinked steel cords as standard.
Kevlar	Kevlar tension cords are suggested for non magnetic, precisely for use in drives with metal detectors, and they also are widely used in food industry.
HP	High performance cords have 25% more strength capacity than standard cords. They are recommended for high repeatability applications.
HF	High flexibility cords can accept smaller pulley and idler diameters than standard cords. They are suitable for multi-shaft drives with severe reverse bending.
HPF	High performance and flexibility cords have 25% more strength capacity like the HP cords, but they are more flexible than the HP cords. They are suggested for high performance and multi-shaft drives.
Stainless steel	Stainless steel cords have 25% less strength capacity than standard cords. They are recommended for water applications.
Fiberglass and polyester	They combine particular mechanical characteristics, such as high flexibility, with resistance to water, polyester cord wet and humid environments.

Special compound and cords have to be tested and homologated on application. Megadyne is not responsible for wrong functioning of special products.

COATING

Megapower belts can be manufactured with special coatings, in order to fit many application with different requirements. For feasibility see table at page 21 and for properties see page 22.

IDENTIFICATION CODE

Using the information in the table below, it is possible to identify the correct belt for every application. The code is composed of letters and numbers as the following example:

1	2	3	4	5	6					
MPW	+	50	+	AT	+	10	+	1500	+	SPECIAL MANUFACTURES

- 1) **MPW** Megapower timing belt.
- 2) **50** This number indicates the width of requested belt.
The value is in mm for a belt with a pitch in mm, and in inches for a belt with a pitch in inches.
- 3) **AT** This code composed by letters indicates the selection of profile.
- 4) **10** This number indicates the standard pitch of the belt. It is expressed in mm.
- 5) **1500** The last number indicates the length of the belt always in mm regardless of pitch.
- 6) **SPECIAL MANUFACTURES:**
 - special cords as Kevlar or HP or HF or HPF or stainless steel or fiberglass or polyester
 - special compound as different hardness or different colours
 - extra coating

POWER TRANSMISSION CALCULATION PROCEDURE

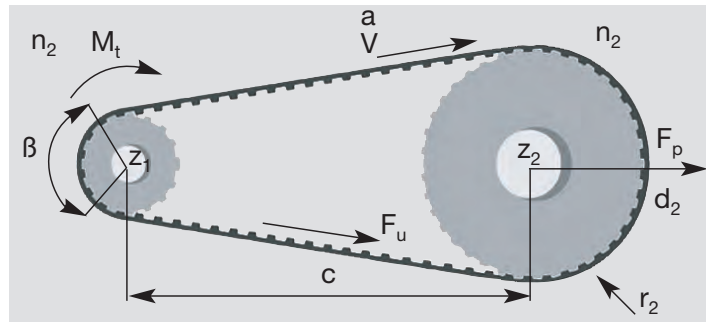

Symbol	Unit	Definition	Symbol	Unit	Definition
t	mm	pitch	F_u	N	transmittable force
b	mm	belt width	F_p	N	pretension
L_w	mm	belt length	i	–	speed ratio
c	mm	center distance	n₁, n₂	RPM	speed of driver / driven pulley
β		arc of contact	d₁, d₂	mm	pitch diameter of driver / driven pulley
C₁, C₂, C₃, C_{TOT}		safety factors	z₁, z₂		no. of teeth of driver/ driven pulley
P	kW	power	z_m		no. of teeth in mesh
P_R	kW/cm	transmittable power each cm of tooth in mesh	M_t	Nm	drive torque
			a	m/s ²	acceleration

DETERMINATION OF BELT PITCH

The belt pitch can be determined with the belt selection chart at page 8 (for new applications we suggest AT profiles), referring to the speed of the small pulley.

DETERMINATION OF SPEED RATIO

The speed ratio represents the ratio of pulley speed n_1 to n_2 , or pulley pitch diameter d_2 to d_1 or of number of teeth z_2 to z_1 .

$$i = \frac{n_1}{n_2} = \frac{d_2}{d_1} = \frac{z_2}{z_1}$$

SELECTION OF REQUIRED TIMING PULLEYS

For the selection of the needed timing pulleys see belt data pages and pulleys catalogue.

CALCULATION OF REQUIRED BELT LENGTH

The belt length can be determined replacing your values in the following formula:

$$L_w[\text{mm}] = 2 \cdot c \cdot \sin \frac{\beta}{2} + \frac{t}{2} \cdot \left[z_1 + z_2 + \left(1 - \frac{\beta}{180} \right) \cdot (z_2 - z_1) \right] \quad \text{where} \quad \beta = \arccos \left[\frac{t \cdot (z_2 - z_1)}{2 \cdot \pi \cdot c} \right]$$

POWER TRANSMISSION CALCULATION PROCEDURE

The actual belt length is to be taken from those available in the table (see belt page), the closest to the calculated L_w .

CALCULATION OF CENTER DISTANCE

The approximate center distance can be determined replacing your values in the following formula:

$$c = \frac{1}{4} \left[L_w - \frac{t}{2} (z_1 + z_2) + \sqrt{\left[L_w - \frac{t}{2} (z_1 + z_2) \right]^2 - \left[\frac{t}{\pi} (z_1 - z_2) \right]^2} \right]$$

CHOICE OF SAFETY FACTOR

The total safety factor C_{TOT} is the correction coefficient for the power (to be transmitted) to obtain the design power.

$$C_{TOT} = C_1 + C_2 + C_3$$

C_1 is the *Acceleration Factor*, used when the inverse of speed ratio i is $> 1,24$

1/i	1,00÷1,24	1,25÷1,74	1,75÷2,49	2,50÷3,49	>3,50
C₁	0	0,1	0,2	0,3	0,4

C_2 is the *Service Factor* depending on the number of the operational hours per day (operation time)

h/day	8÷10	10÷16	16÷24	Intermittent	Seasonal
C₂	0	+0,1	+0,2	-0,1	-0,1

C_3 is the *Load Factor* depending on the type of driver used by internal transmission of the driven machine. For C_3 values see the table 1 at page 8.

DETERMINATION OF NUMBER OF TEETH IN MESH

The number of the teeth in mesh can be determined replacing your values in the following formula:

$$z_m = \frac{z_1 \cdot \beta}{360}$$

If calculated z_m is above 12, consider $z_m = 12$ (maximum number of teeth in mesh)

DETERMINATION OF BELT WIDTH

The belt width is calculated using the transmittable power P_R per tooth in mesh and per cm belt width (see table at belt page).

$$b[\text{mm}] = \frac{P \cdot C_{TOT} \cdot 10}{P_R \cdot z_m}$$

CALCULATION PARAMETERS

BELT SELECTION CHART

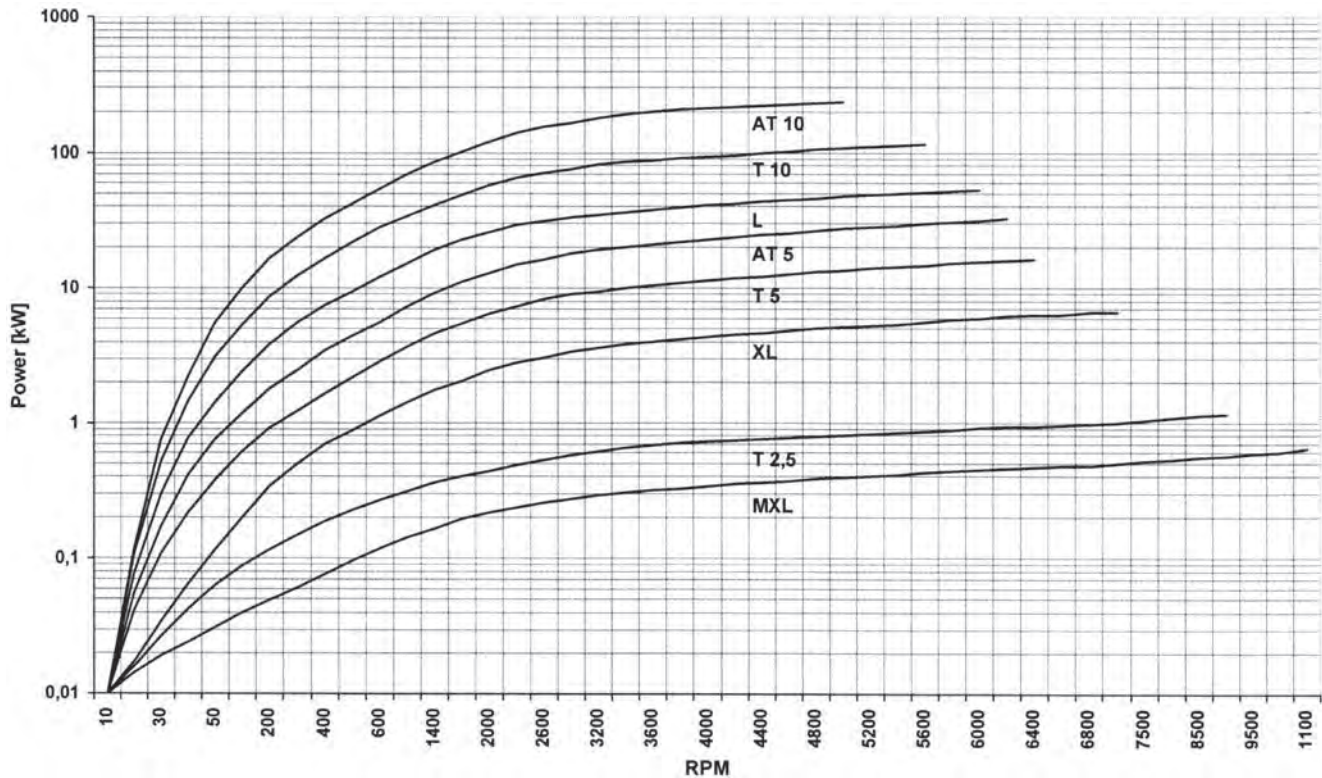

Table 1 - Load Factor C_3

Driven Machine	Driver			Driven Machine	Driver		
	Type A	Type B	Type C		Type A	Type B	Type C
Office machinery				Sawmill machinery	1,4	1,6	1,8
Typewriters	1	1,1	1,2	Brick machinery			
Computers, printers	1,1	1,2	1,3	Mixers	1,4	1,6	1,8
Teleprinters, photocopiers	1,1	1,2	1,3	Pug mills	1,6	1,8	2
Motion-picture projectors and cameras	1	1,2	1,2	Textile machinery			
Domestic machinery				Spoolers and warping machines	1,2	1,4	1,6
Centrifuges	1	1,1	1,2	Spinning and twisting machines	1,3	1,5	1,7
Kitchen appliances, universal slicers	1,1	1,2	1,3	Paper machinery			
Sewing machines				Agitators, calenders, driers	1,2	1,4	1,6
Domestic sewing machines	1,1	1,2	1,3	Pumps, beaters, pulpers	1,4	1,6	1,8
Industrial sewing machines	1,2	1,3	1,4	Printing machinery			
Laundry machinery				Linotype machines, cutters, folders	1,2	1,4	1,6
Driers	1,2	1,4	1,6	Rotary presses	1,3	1,5	1,7
Washing machines	1,4	1,6	1,8	Screens			
Bakery machinery and dough mixers	1,2	1,4	1,6	Drum screens	1,2	1,4	1,6
Conveyors				Vibrating screens	1,3	1,5	1,7
Light-duty belt conveyors	1,1	1,2	1,3	Fans, Blowers			
Belt conveyor for ore, coal, sand	1,2	1,4	1,6	Exhauster, radial blowers	1,4	1,6	1,8
Heavy duty conveyors	1,4	1,6	1,8	Mine ventilators, axial blowers	1,6	1,8	2
Elevators, screw conveyors	1,4	1,6	1,8	Compressors			
Bucket elevators	1,4	1,6	1,8	Helical compressors	1,4	1,5	1,6
Agitators				Piston compressors	1,6	1,8	2
Mixers for liquids	1,2	1,4	1,6	Pumps			
Mixers for semi-liquids	1,3	1,5	1,7	Centrifugal and gear pumps	1,2	1,4	1,6
Machine tools				Reciprocating pumps	1,7	1,9	2,1
Lathes	1,2	1,4	1,6	Generators and exciters	1,4	1,6	1,8
Drills and grinders	1,3	1,5	1,7	Elevators and hoists	1,4	1,6	1,8
Millers and planers	1,3	1,5	1,7	Centrifuges	1,5	1,7	1,9
Woodworking machinery				Rubber machinery	1,5	1,7	1,9
Lathes and band saws	1,2	1,3	1,5	Mills			
Planers and disk saws	1,2	1,4	1,6	Hammer mills	1,5	1,7	1,9
				Ball, roller and gravel mills	1,7	1,9	2,1

Type A: electric motors with low starting torque (up to 1,5 times the rated torque).

Type B: electric motors with normal starting torque (1,5 to 2,5 times the rated torque).

Type C: electric motors with high starting and breaking torque (over 2,5 times the related torque).

BELT CALCULATION EXAMPLE

DRIVER DATA

electric motor $P = 2\text{kW}$
 $n = 3000\text{RPM}$
 Low starting torque

MACHINE DATA

Wood working machine
 $N = 900\text{RPM}$
 Max diameter driven pulley 110mm
 $c = 300\text{mm}$

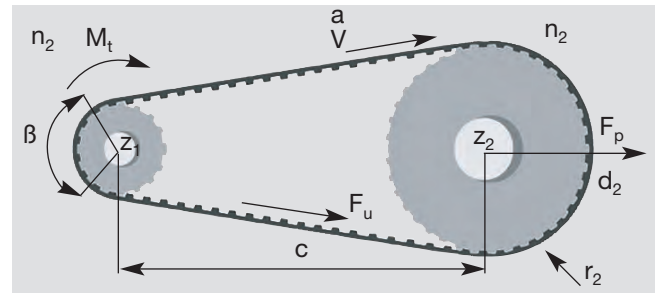

DETERMINATION OF BELT PITCH

According Belt selection chart at page 8, considering values of $P = 2\text{kW}$ and $n = 3000\text{RPM}$, it is possible to choose T5 AT5 L T10 or AT10.
 We choose T10.

DETERMINATION OF SPEED RATIO

$$i = \frac{n_1}{n_2} = \frac{3000}{900} = 3.33$$

SELECTION OF REQUIRED TIMING PULLEYS

According page 18 we choose $z_2 = 36$ $d_2 = 108.36\text{mm}$

$$d_1 = \frac{d_2}{i} = \frac{108.36}{3.33} = 32.54\text{mm} \text{ and from page 18 we choose pulley diameter is for } z_1 = 12$$

Actual speed ratio

$$i = \frac{z_2}{z_1} = \frac{36}{12} = 3$$

CALCULATION OF REQUIRED BELT LENGTH

$\beta = 166^\circ$ and $L = 845\text{mm}$

From page 18, closest length to calculates is $L_w = 850\text{mm}$.

CALCULATION OF CENTER DISTANCE

The approximate center distance: $c = 302,6\text{mm}$

CHOICE OF SAFETY FACTOR

From table page 7, we select $C_1 = 0,3$ $c_2 = 0$

From Table page 8, we select $C_3 = 1,2$

So $C_{TOT} = 1,5$

DETERMINATION OF NUMBER OF TEETH IN MESH

The number of the teeth in mesh can be determined replacing your values in the following formula:

$$z_m = \frac{z \cdot \beta}{360} = 5$$

DETERMINATION OF BELT WIDTH

From page 18, for $z = 12$ and $n = 3000$ $P_R = 0.133\text{kW}$ so $b = \frac{P \cdot C_{TOT} \cdot 10}{P_R \cdot z_m} = 47.24\text{mm}$

From page 18, closest width is 50mm

The choice for transmission is belt 50 T10 850, driver pulley 56T10 12 and driven pulley 56 T10 36

BELT INSTALLATION

For a correct system functioning and to increase belt life, it is necessary a correct pulley installation: pulleys has to be parallel and aligned as shown in drawing 1 (correct configuration).

If pulleys are not parallel as in drawing 2, belt could fall during functioning and this can provoke damages to complete equipment.

To grant a correct belt running, α and Δx must be as smaller as possible. For more information, please contact our technical staff.

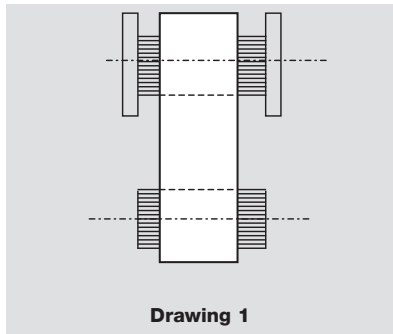

Drawing 1

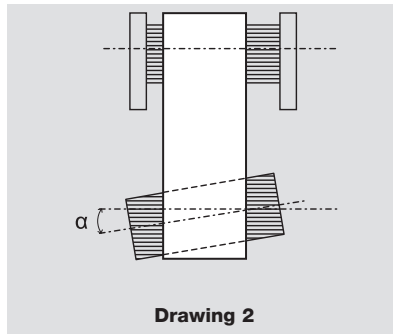

Drawing 2

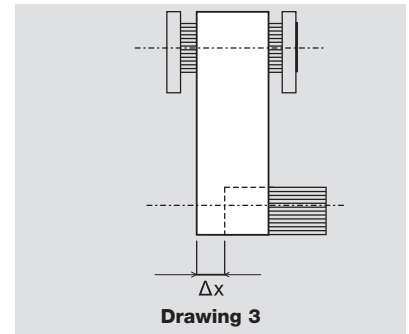

Drawing 3

CALCULATION OF PRETENSION FORCE FP

The pretension force is the load which has to be applied to the center of one of the driving system's pulleys in static conditions to avoid the derailing of the belt.

$$F_p = 2 \cdot F_v \cdot \sin \frac{\beta}{2}$$

For:

- $z < 60$ $F_v = \frac{1}{3} \cdot F_u$

- $60 < z < 150$ $F_v = \frac{1}{2} \cdot F_u$

- $z > 150$ $F_v = \frac{2}{3} \cdot F_u$

where
$$F_u = \frac{60 \cdot 10^6 \cdot P \cdot \sin \frac{\beta}{2}}{t \cdot n_1 \cdot z_1}$$

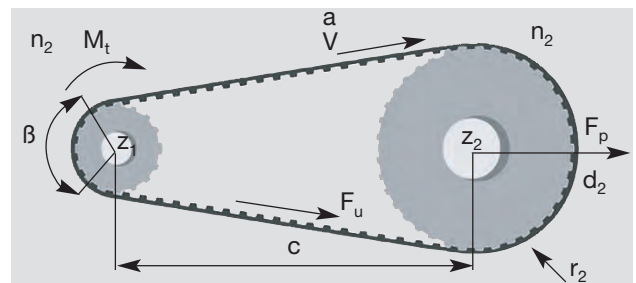

MEASURING PROCEDURE

The procedure to measure the tension of the belt is to use a Belt Tensioning Gauging Equipment. This device consists of a small sensing head which is held across the belt to be measured. The belt is then tapped to induce the belt to vibrate at its natural frequency. The vibrations are detected and the frequency of vibration is then displayed on the measuring unit. The relation between belt static tension (T_s) and frequency of vibration (f) may be calculated using the following formula:

$$f = \frac{1}{2t} \cdot \sqrt{\frac{T_s}{m}} \quad \text{or} \quad T_s = 4 \cdot m \cdot t^2 \cdot f^2$$

m = belt mass per unit length (kg/m) t = free belt span length in meters (m)

T_s = static tension (N) f = frequency of vibration (Hz)



CAUSES OF BELT FAILURE

To ensure that the performance and durability of a toothed belt drive will fully meet requirements of a particular application, it is necessary firstly to accurately select the drive and then to make sure the drive is correctly installed. If this procedure is not followed, the drive life and efficiency may be considerably reduced. The most frequent problems encountered and their probable causes are listed in the table below.

Problems	Causes	Corrective actions
Abnormal wear of the belt: a) on the side of the tooth	Belt excessively taut	Reduce centre distance
	Excessive overloading	Use a wider belt
	Incorrect contour or diameter of pulley	Replace pulley after checking contour or diameter
b) on the bottom of the tooth	Excessive installation tension	Reduce centre distance
c) at the tooth root	Incorrect diameter of pulley	Replace pulley after checking diameter
d) on the side of the belt	Incorrect contour or diameter of pulley	Replace pulley after checking contour or diameter
	Misalignment or wrong setting of pulleys	Replace pulley after checking contour or diameter
	Oscillation of the axes and/or of the bearings	Correct the positioning of the pulleys and reinforce the bearings
	Flanges bent	Straighten flanges
Failure through traction or through laceration of the teeth, indicating corrosion of the tension member	Diameter of small pulley i.e. below the minimum	Increase the diameter of the pulleys or use belts and pulleys of smaller pitch
	Excessive moisture	Eliminate the moisture
Laceration of belt teeth	Number of teeth in mesh less than six	Increase the number of teeth in mesh or use belts and pulleys of smaller pitch
	Excessive load	Use a wider belt
Rupture of tension member	Excessive load	Use a wider belt
	Diameter of pulley below minimum	Increase the diameter of the pulleys
Breaks or cracks in the top surface of the belt	Exposure to excessively low temperatures (below -25°C)	Eliminate the low temperature
Softening of the top surface of the belt	Exposure to excessively high temperatures (below $+85^{\circ}\text{C}$) or operation with excessive amount of oil present	Eliminate the high temperature or reduce the amount of oil present
Apparent elongation of the belt	Reduction of centre distance due to bearings not being firmly fixed	Restore the initial centre distance and strengthen the bearings
Belt overriding the flanges	Faulty installation of the flanges	Reinstall the flanges correctly
	Misalignment of pulleys	Align pulleys
Excessive wear of pulley teeth	Excessive overloading	Use a wider belt
	Belt excessively taut	Reduce the centre distance
	Pulley material insufficiently hard	Harden the pulley surface
Drive excessively noisy	Pulleys out of line	Align pulleys
	Excessive installation tension	Reduce the centre distance
	Excessive load	Use a wider belt
	Diameter of pulley below minimum	Increase the diameter of the pulleys

MEGAPOWER MXL

BELT CHARACTERISTICS

BELT WIDTH (mm)	3,2 (012")	4,8 (019")	6,4 (025")
PULLEY WIDTH B2 (mm)	5,6	7,1	8,9
BELT WEIGHT (gr/cm)	0,035	0,053	0,073

Standard compound: **Thermoset PU 88 ShA grey/green**

Standard cords: **Twisted Zinked Steel**

Standard belt width tolerance: **+ 0,50 / - 0,80 mm**

Standard sleeve width tolerance: **+/- 10 mm**

Standard thickness tolerance: **+/- 0,20 mm**

Special version belts on request, **see page 24**

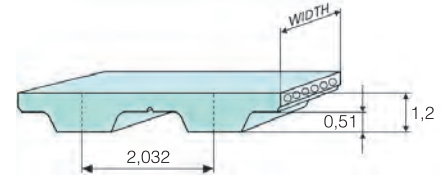

BELT LENGTHS AND TOLERANCES

Code	44	45,6	48	56	57,6	60	60,8	63,2	64	65,6	70,4	72,8	73,6	76,8	78,4	80,8	81,6
Length (mm)	111,7	115,8	121,9	142,2	146,3	152,4	154,4	160,5	162,5	166,6	178,8	184,9	186,9	195,1	199,1	205,2	207,2
No. of teeth	55	57	60	70	72	75	76	79	80	82	88	91	92	96	98	101	102
Length tolerance (mm)	+/- 0,28																
Code	82,4	84	88	91,2	94,4	96	97,6	104	105,6	108	112	116	120	124	140	152	160
Length (mm)	209,2	213,4	223,5	231,6	239,8	243,8	247,9	264,1	268,2	274,3	284,4	294,6	304,8	314,9	355,6	386,1	406,4
No. of teeth	103	105	110	114	118	120	122	130	132	135	140	145	150	155	175	190	200
Length tolerance (mm)	+/- 0,28													+/- 0,32			
Code	176,8	204,8	224	228	246,4	252	260	265,6	281,6	288	316	324	329,6	345,6	363,2	388	
Length (mm)	449,1	520,1	568,9	579,1	625,8	640	660,4	674,6	715,2	731,5	802,6	822,9	837,1	877,8	922,5	985,5	
No. of teeth	221	256	280	285	308	315	325	332	352	360	395	405	412	432	454	485	
Length tolerance (mm)	+/- 0,36		+/- 0,42			+/- 0,48				+/- 0,56							

TRANSMITTABLE POWER (kW/cm of tooth in mesh)

n/z	10	12	14	16	18	20	24	26	28	30	32	36	40
600	0,00137	0,00164	0,00191	0,00218	0,00246	0,00273	0,00328	0,00355	0,00382	0,00410	0,00437	0,00491	0,00546
800	0,00172	0,00206	0,00240	0,00275	0,00309	0,00343	0,00412	0,00446	0,00481	0,00515	0,00549	0,00618	0,00686
1000	0,00204	0,00245	0,00286	0,00327	0,00368	0,00409	0,00491	0,00532	0,00573	0,00613	0,00654	0,00736	0,00818
1400	0,00265	0,00318	0,00371	0,00424	0,00477	0,00530	0,00636	0,00689	0,00742	0,00795	0,00848	0,00954	0,01060
1800	0,00320	0,00384	0,00448	0,00513	0,00577	0,00641	0,00769	0,00833	0,00897	0,00961	0,01025	0,01153	0,01281
2000	0,00346	0,00416	0,00485	0,00554	0,00624	0,00693	0,00831	0,00901	0,00970	0,01039	0,01109	0,01247	0,01386
3000	0,00465	0,00558	0,00651	0,00744	0,00837	0,00930	0,01115	0,01208	0,01301	0,01394	0,01487	0,01673	0,01859
4000	0,00568	0,00681	0,00795	0,00908	0,01022	0,01136	0,01363	0,01476	0,01590	0,01703	0,01817	0,02044	0,02271
5000	0,00659	0,00791	0,00923	0,01055	0,01187	0,01319	0,01583	0,01715	0,01846	0,01978	0,02110	0,02374	0,02638
8000	0,00886	0,01063	0,01240	0,01417	0,01594	0,01771	0,02125	0,02302	0,02480	0,02657	0,02834	0,03188	0,03542

PULLEYS (for more details see our pulleys catalogue)

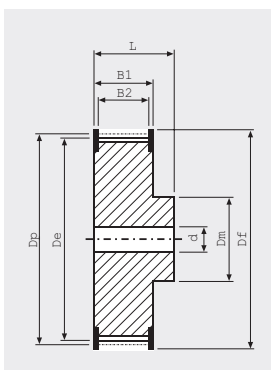

No. teeth	Dp	De	No. teeth	Dp	De
10	6,47	5,96	26	16,81	16,30
12	7,76	7,25	28	18,11	17,60
13	8,41	7,90	30	19,40	18,89
14	9,06	8,55	32	20,70	20,19
15	9,70	9,19	34	21,99	21,48
16	10,35	9,84	36	23,29	22,78
17	11,00	10,49	40	25,87	25,36
18	11,64	11,13	42	27,17	26,66
19	12,29	11,78	44	28,46	27,95
20	12,94	12,43	48	31,05	30,54
21	13,58	13,07	60	38,81	38,30
22	14,23	13,72	65	42,04	41,53
24	15,52	15,01	72	46,57	46,06

BELT CHARACTERISTICS

BELT WIDTH (mm)	6,4 (025")	7,9 (031")	9,4 (037")
PULLEY WIDTH B2 (mm)	8,9	10,4	12,2
BELT WEIGHT (gr/cm)	0,121	0,153	0,182

Standard compound: **Thermoset PU 88 ShA grey/green**
 Standard cords: **Twisted Zinked Steel**
 Standard belt width tolerance: **+ 0,50 / - 0,80 mm**
 Standard sleeve width tolerance: **+/- 10 mm**
 Standard thickness tolerance: **+/- 0,20 mm**
 Special version belts on request, **see page 24**

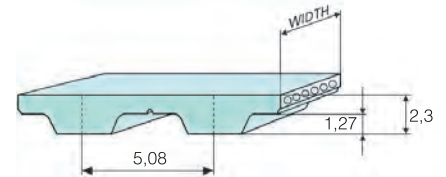

BELT LENGTHS AND TOLERANCES

Code	60	70	76	80	90	100	110	120	130	134	140	150	160				
Length (mm)	152,4	177,8	193	203,2	228,6	254	279,4	304,8	330,2	340,3	355,6	381	406,4				
No. of teeth	30	35	38	40	45	50	55	60	65	67	70	75	80				
Length tolerance (mm)	+/- 0,28						+/- 0,32			+/- 0,36							
Code	170	180	190	194	200	210	220	230	240	250	260	270	288	290	300	356	414
Length (mm)	431,8	457,2	482,6	492,7	508	533,4	558,8	584,2	609,6	635	660,4	685,8	731,5	736,6	762	904,2	1051,5
No. of teeth	85	90	95	97	100	105	110	115	120	125	130	135	144	145	150	178	207
Length tolerance (mm)	+/- 0,36					+/- 0,42					+/- 0,48					+/-0,56	+/-0,64
Code	450	566															
Length (mm)	1143	1437,6															
No. of teeth	225	283															
Length tolerance (mm)	+/-0,64	+/-0,76															

TRANSMITTABLE POWER (kW/cm of tooth in mesh)

n/z	10	12	14	16	18	20	24	28	32	40	48	60	72
100	0,0016	0,0019	0,0022	0,0026	0,0029	0,0032	0,0038	0,0045	0,0051	0,0064	0,0077	0,0096	0,0115
200	0,0029	0,0035	0,0041	0,0047	0,0053	0,0059	0,0070	0,0082	0,0094	0,0117	0,0141	0,0176	0,0211
600	0,0075	0,0091	0,0106	0,0121	0,0136	0,0151	0,0181	0,0211	0,0241	0,0302	0,0362	0,0453	0,0543
1000	0,0116	0,0139	0,0162	0,0186	0,0209	0,0232	0,0278	0,0325	0,0371	0,0464	0,0557	0,0696	0,0835
1500	0,0162	0,0195	0,0227	0,0260	0,0292	0,0325	0,0390	0,0455	0,0520	0,0650	0,0780	0,0975	0,1170
2000	0,0206	0,0247	0,0288	0,0329	0,0370	0,0411	0,0494	0,0576	0,0658	0,0823	0,0988	0,1234	0,1481
3000	0,0286	0,0343	0,0400	0,0457	0,0514	0,0571	0,0685	0,0799	0,0914	0,1142	0,1370	0,1713	0,2056
4000	0,0359	0,0431	0,0502	0,0574	0,0646	0,0718	0,0861	0,1005	0,1148	0,1435	0,1722	0,2153	0,2584
5000	0,0427	0,0513	0,0598	0,0684	0,0769	0,0855	0,1026	0,1197	0,1368	0,1710	0,2051	0,2564	0,3077
8000	0,0612	0,0735	0,0857	0,0980	0,1102	0,1225	0,1470	0,1715	0,1960	0,2450	0,2940	0,3675	0,4410

PULLEYS (for more details see our pulleys catalogue)

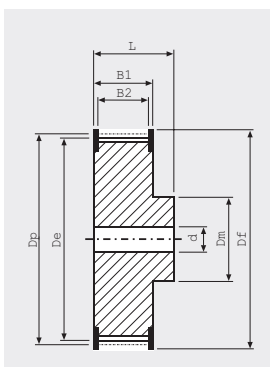

No. teeth	Dp	De	No. teeth	Dp	De
10	16,17	15,66	26	42,04	41,53
11	17,79	17,28	28	45,28	44,77
12	19,40	18,89	30	48,51	48,00
13	21,02	20,51	32	51,74	51,23
14	22,64	22,13	36	58,21	57,70
15	24,26	23,75	40	64,68	64,17
16	25,87	25,36	42	67,91	67,40
17	27,49	26,98	44	71,15	70,64
18	29,11	28,60	48	77,62	77,11
20	32,34	31,83	56	90,55	90,04
22	35,57	35,07	60	97,02	96,51
24	38,81	38,30	72	116,43	115,92

MEGAPOWER L

BELT CHARACTERISTICS

BELT WIDTH (mm)	12,7 (050")	19,1 (075")	25,4 (100")
PULLEY WIDTH B2 (mm)	19	25,4	29,7
BELT WEIGHT (gr/cm)	0,437	0,661	0,878

Standard compound: **Thermoset PU 88 ShA grey/green**

Standard cords: **Twisted Zinked Steel**

Standard belt width tolerance: **+/- 0,80 mm**

Standard sleeve width tolerance: **+/- 10 mm**

Standard thickness tolerance: **+/- 0,30 mm**

Special version belts on request, **see page 24**

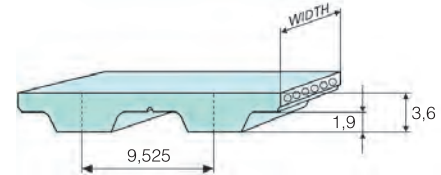

BELT LENGTHS AND TOLERANCES

Code	86	124	150	173	187	202	210	225	240	255	270	285	300	322	345	367
Length (mm)	218,6	314,3	381	438,2	476,2	514,4	533,4	571,5	609,6	647,7	685,8	723,9	762	819,2	876,3	933,4
No. of teeth	23	33	40	46	50	54	56	60	64	68	72	76	80	86	92	98
Length tolerance (mm)	+/-0,28	+/-0,32			+/-0,36			+/-0,42				+/-0,48			+/-0,56	

Code	390	420	450	480	510	540	570	600
Length (mm)	990,6	1066,8	1143	1219,2	1295,4	1371,6	1447,8	1524
No. of teeth	104	112	120	128	136	144	152	160
Length tolerance (mm)		+/-0,64				+/-0,76		

TRANSMITTABLE POWER (kW/cm of tooth in mesh)

n/z	10	12	14	16	18	20	22	24	28	30	32	36	40
100	0,0050	0,0060	0,0070	0,0079	0,0089	0,0099	0,0109	0,0119	0,0139	0,0149	0,0159	0,0179	0,0199
200	0,0089	0,0107	0,0125	0,0143	0,0161	0,0178	0,0196	0,0214	0,0250	0,0268	0,0285	0,0321	0,0357
600	0,0219	0,0263	0,0307	0,0351	0,0394	0,0438	0,0454	0,0482	0,0530	0,0568	0,0606	0,0681	0,0757
1000	0,0328	0,0393	0,0459	0,0524	0,0590	0,0655	0,0721	0,0786	0,0917	0,0983	0,1048	0,1179	0,1311
1500	0,0447	0,0536	0,0625	0,0715	0,0804	0,0894	0,0983	0,1072	0,1251	0,1340	0,1430	0,1608	0,1787
2000	0,0553	0,0664	0,0775	0,0885	0,0996	0,1107	0,1218	0,1328	0,1550	0,1660	0,1771	0,1992	0,2214
3000	0,0741	0,0889	0,1037	0,1185	0,1333	0,1482	0,1630	0,1778	0,2074	0,2222	0,2370	0,2667	0,2963
4000	0,0903	0,1084	0,1264	0,1445	0,1626	0,1806	0,1987	0,2168	0,2529	0,2709	0,2890	0,3251	0,3613
5000	0,1047	0,1256	0,1466	0,1675	0,1885	0,2094	0,2303	0,2513	0,2932	0,3141	0,3350	0,3769	0,4188
8000	0,1399	0,1679	0,1958	0,2238	0,2518	0,2798	0,3078	0,3357	0,3917	0,4197	0,4477	0,5036	0,5596

PULLEYS (for more details see our pulleys catalogue)

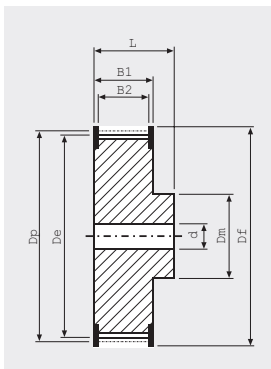

No. teeth	Dp	De	No. teeth	Dp	De
10	30,32	29,56	30	90,96	90,20
11	33,35	32,59	32	97,02	96,26
12	36,38	35,62	34	103,08	102,32
13	39,41	38,65	36	109,15	108,39
14	42,45	41,69	40	121,28	120,52
16	48,51	47,75	42	127,34	126,58
18	54,57	53,81	44	133,40	132,64
20	60,64	59,88	48	145,53	144,76
22	66,70	65,94	52	157,66	156,90
24	72,77	72,01	56	169,79	169,03
26	78,83	78,07	60	181,91	181,15
28	84,89	84,13	72	218,30	217,54

BELT CHARACTERISTICS

BELT WIDTH (mm)	19,1 (075")	25,4 (100")	38,1 (150")	50,8 (200")	76,2 (300")
PULLEY WIDTH B2 (mm)	25,4	29,7	46	59	85
BELT WEIGHT (gr/cm)	0,745	1,059	1,594	2,121	3,194

Standard compound: **Thermoset PU 88 ShA grey/green**

Standard cords: **Twisted Zinked Steel**

Standard belt width tolerance: **+/- 0,80 mm**

Standard sleeve width tolerance: **+/- 10 mm**

Standard thickness tolerance: **+/- 0,30 mm**

Special version belts on request, **see page 24**

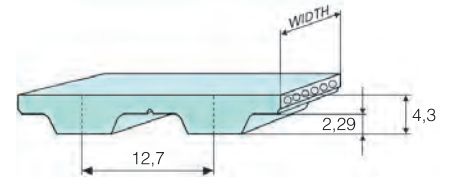

BELT LENGTHS AND TOLERANCES

Code	230	240	270	300	330	360	390	420	450	480	510
Length (mm)	584,2	609,6	685,8	762	838,2	914,4	990,6	1066,8	1143	1219,2	1295,4
No. of teeth	46	48	54	60	66	72	78	84	90	96	102
Length tolerance (mm)	+/-0,42		+/-0,56		+/-0,64			+/-0,76		+/-0,88	

TRANSMITTABLE POWER (kW/cm of tooth in mesh)

n/z	14	16	18	20	22	24	26	28	30	32	36	40	44
100	0,0128	0,0142	0,0163	0,0185	0,0199	0,0213	0,0234	0,0255	0,0277	0,0293	0,0341	0,0362	0,0394
200	0,0229	0,0255	0,0293	0,0331	0,0357	0,0382	0,0421	0,0459	0,0497	0,0526	0,0611	0,0650	0,0709
600	0,0563	0,0626	0,0720	0,0814	0,0876	0,0939	0,1033	0,1127	0,1221	0,1291	0,1502	0,1596	0,1741
1000	0,0842	0,0936	0,1077	0,1217	0,1311	0,1404	0,1545	0,1685	0,1826	0,1931	0,2247	0,2387	0,2603
1500	0,1149	0,1276	0,1468	0,1659	0,1787	0,1915	0,2107	0,2298	0,2490	0,2633	0,3064	0,3256	0,3550
2000	0,1423	0,1581	0,1818	0,2056	0,2214	0,2372	0,2609	0,2846	0,3084	0,3262	0,3795	0,4032	0,4397
3000	0,1905	0,2116	0,2434	0,2751	0,2963	0,3175	0,3493	0,3810	0,4128	0,4366	0,5080	0,5398	0,5886
4000	0,2322	0,2580	0,2968	0,3355	0,3613	0,3871	0,4258	0,4645	0,5032	0,5322	0,6193	0,6580	0,7176
5000	0,2692	0,2991	0,3440	0,3889	0,4188	0,4487	0,4936	0,5384	0,5833	0,6170	0,7179	0,7628	0,8319
8000	0,3597	0,3997	0,4597	0,5196	0,5596	0,5995	0,6595	0,7194	0,7794				

PULLEYS (for more details see our pulleys catalogue)

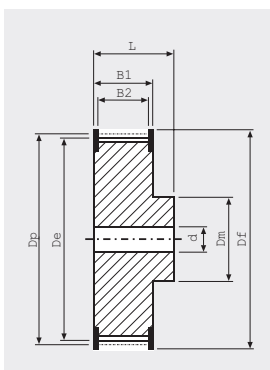

No. teeth	Dp	De	No. teeth	Dp	De
14	56.60	55.23	30	121.28	119.91
15	60.64	59.27	32	129.36	127.99
16	64.68	63.31	34	137.45	136.08
18	72.77	71.40	36	145.53	144.16
20	80.85	79.48	38	153.62	152.25
21	84.89	83.52	40	161.70	160.33
22	88.94	87.57	44	177.87	176.50
23	92.98	91.61	48	194.04	192.67
24	97.02	95.65	52	210.21	208.84
25	101.06	99.69	58	234.47	233.10
26	105.11	103.74	60	242.55	241.18
28	113.19	111.82	72	291.06	289.69

MEGAPOWER T2,5

BELT CHARACTERISTICS

BELT WIDTH (mm)	4	6	8	10	12
PULLEY WIDTH B2 (mm)	8	10	12	14	16
BELT WEIGHT (gr/cm)	0,046	0,070	0,093	0,120	0,143

Standard compound: **Thermoset PU 88 ShA grey/green**

Standard cords: **Twisted Zinked Steel**

Standard belt width tolerance: **+/- 0,30 mm**

Standard sleeve width tolerance: **+/- 10 mm**

Standard thickness tolerance: **+/- 0,15 mm**

Special version belts on request, **see page 24**

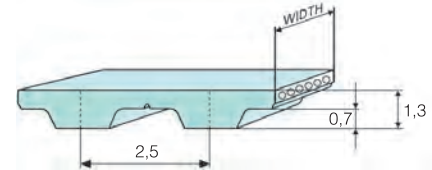
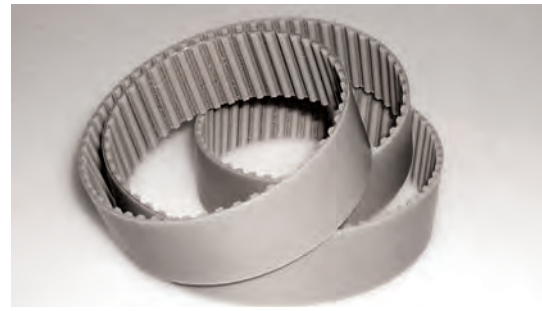

BELT LENGTHS AND TOLERANCES

Length (mm)	120	145	160	177,5	180	182,5	200	210	230	245	265	277,5	285	290	305	317,5	330	342,5	380	
No. of teeth	48	58	64	71	72	73	80	84	92	98	106	111	114	116	122	127	132	137	152	
Length tolerance (mm)																+/-0,28		+/-0,32		

Length (mm)	420	480	500	540	600	620	650	680	700	780	880	915	950	1185
No. of teeth	168	192	200	216	240	248	260	272	280	312	352	366	380	474
Length tolerance (mm)	+/-0,36		+/-0,42			+/-0,48			+/-0,56			+/-0,64		

TRANSMITTABLE POWER (kW/cm of tooth in mesh)

n/z	10	12	14	16	18	20	22	24	26	28	30	36	40
800	0,00195	0,00234	0,00273	0,00312	0,00351	0,00390	0,00429	0,00468	0,00507	0,00546	0,00585	0,00702	0,0078
600	0,00245	0,00294	0,00343	0,00392	0,00441	0,00490	0,00539	0,00588	0,00637	0,00686	0,00736	0,00883	0,00981
1000	0,00292	0,00351	0,00409	0,00467	0,00526	0,00580	0,00642	0,00700	0,00759	0,00817	0,00877	0,01052	0,01169
1400	0,00379	0,00454	0,00530	0,00606	0,00681	0,00757	0,00833	0,00909	0,00984	0,01060	0,01136	0,01363	0,01514
1500	0,00419	0,00503	0,00586	0,00670	0,00754	0,00838	0,00922	0,01005	0,01089	0,01173	0,01257	0,01508	0,01676
2000	0,00495	0,00594	0,00693	0,00742	0,00891	0,00990	0,01089	0,01188	0,01287	0,01386	0,01485	0,01782	0,01980
3000	0,00664	0,00797	0,00930	0,01062	0,01195	0,01328	0,01461	0,01594	0,01726	0,01859	0,01992	0,02390	0,02656
4000	0,00811	0,00973	0,01136	0,01298	0,01460	0,01622	0,01785	0,01947	0,02109	0,02271	0,02433	0,02920	0,03245
5000	0,00942	0,01130	0,01319	0,01507	0,01696	0,01884	0,02073	0,02261	0,02449	0,02638	0,02826	0,03391	0,03768
8000	0,01265	0,01518	0,01771	0,02024	0,02277	0,02530	0,02783	0,03036	0,03289	0,03542	0,03795	0,04554	0,05060

PULLEYS (for more details see our pulleys catalogue)

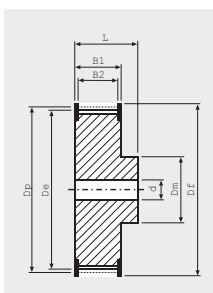

No. teeth	Dp	De	No. teeth	Dp	De
10	7,96	7,45	22	17,51	17,00
11	8,75	8,25	24	19,10	18,55
12	9,55	9,00	26	20,69	20,15
13	10,34	9,80	28	22,28	21,75
14	11,14	10,60	30	23,87	23,35
15	11,94	11,40	32	25,46	24,95
16	12,73	12,20	36	28,65	28,10
17	13,53	13,00	40	31,83	31,30
18	14,32	13,80	44	35,01	34,50
19	15,12	14,60	48	38,20	37,70
20	15,92	15,40	60	47,75	47,25
21	16,71	16,20	72	57,30	55,20

BELT CHARACTERISTICS

BELT WIDTH (mm)	6	8	10	12	16	20	25
PULLEY WIDTH B2 (mm)	12	13	15	17	21	25	30
BELT WEIGHT (gr/cm)	0,116	0,152	0,194	0,237	0,249	0,390	0,497

Standard compound: **Thermoset PU 88 ShA grey/green**

Standard cords: **Twisted Zinked Steel**

Standard belt width tolerance: **+/- 0,50 mm**

Standard sleeve width tolerance: **+/- 10 mm**

Standard thickness tolerance: **+/- 0,15 mm**

Special version belts on request, **see page 24**

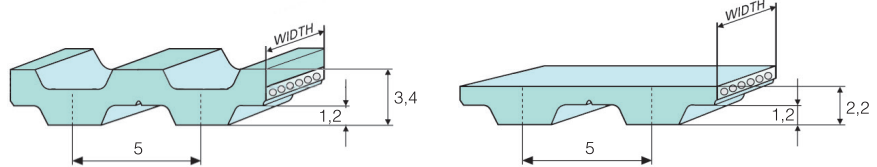
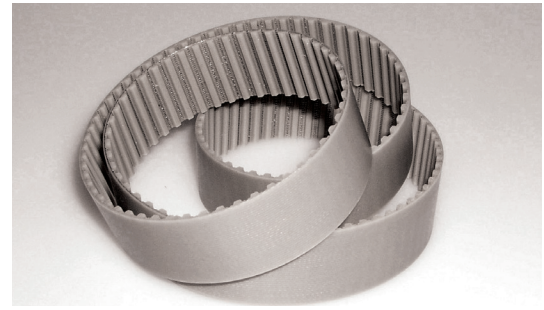

BELT LENGTHS AND TOLERANCES

Length (mm)	120	150	165	180	185	200	210	215	220	225	245	250	255	260	270	275	280	295	300	305			
No. of teeth	24	30	33	36	37	40	42	43	44	45	49	50	51	52	54	55	56	59	60	61			
Length tolerance (mm)	+/-0,28																						
Length (mm)	330	340	350	355	365	375	390	395	400	410	420	425	440	445	450	455	460	475	480	500	510	515*	525
No. of teeth	66	68	70	71	73	75	78	79	80	82	84	85	88	89	90	91	92	95	96	100	102	103	105
Length tolerance (mm)	+/-0,32												+/-0,36										
Length (mm)	545	550	560*	575	590	600	610	620	630	640	650	660	675	690	700	720	725	750	765	780	800	815	
No. of teeth	109	110	112	115	118	120	122	124	126	128	130	132	135	138	140	144	145	150	153	156	160	163	
Length tolerance (mm)	+/-0,42											+/-0,48											
Length (mm)	830	840	850	860	885	900	920	940	990	1000	1075	1100	1130	1160	1200	1215	1275	1280	1315	1355	1380	1440	
No. of teeth	166	168	170	172	177	180	184	188	198	200	215	220	226	232	240	243	255	256	263	271	276	288	
Length tolerance (mm)	+/-0,56									+/-0,64						+/-0,76							
Length (mm)	1470	1500	1580	1690	1955																		
No. of teeth	294	300	316	338	391																		
Length tolerance (mm)	+/-0,76		+/-0,88																				

DOUBLETOOTHED BELT LENGTHS

Length (mm)	410	460	515	525	550	590	620	650	685	700	750	815	840	860	940	1075	1100
No. of teeth	82	92	103	105	110	118	124	130	137	140	150	163	168	172	188	215	220
Length tolerance (mm)	+/-0,36		+/-0,42			+/-0,48			+/-0,56			+/-0,64					

TRANSMITTABLE POWER (kW/cm of tooth in mesh)

n\z	10	12	14	16	18	20	24	28	36	42	48	54	60
100	0,0018	0,0022	0,0025	0,0029	0,0032	0,0036	0,0043	0,0050	0,0065	0,0076	0,0086	0,0097	0,0108
200	0,0034	0,0041	0,0047	0,0054	0,0061	0,0068	0,0081	0,0095	0,0122	0,0142	0,0162	0,0183	0,0203
600	0,0087	0,0104	0,0122	0,0139	0,0157	0,0174	0,0209	0,0244	0,0313	0,0365	0,0418	0,0470	0,0522
1000	0,0132	0,0159	0,0185	0,0212	0,0238	0,0265	0,0318	0,0370	0,0476	0,0556	0,0635	0,0714	0,0794
1500	0,0183	0,0219	0,0256	0,0292	0,0329	0,0365	0,0438	0,0511	0,0657	0,0767	0,0876	0,0986	0,1096
2000	0,0228	0,0274	0,0319	0,0365	0,0410	0,0456	0,0547	0,0638	0,0821	0,0958	0,1094	0,1231	0,1368
3000	0,0309	0,0371	0,0433	0,0494	0,0556	0,0618	0,0742	0,0865	0,1112	0,1298	0,1483	0,1669	0,1854
4000	0,0381	0,0457	0,0533	0,0610	0,0686	0,0762	0,0914	0,1067	0,1372	0,1600	0,1829	0,2057	0,2286
5000	0,0450	0,0540	0,0630	0,0720	0,0810	0,0900	0,1080	0,1260	0,1620	0,1889	0,2159	0,2429	0,2699
8000	0,0645	0,0774	0,0903	0,1032	0,1160	0,1289	0,1547	0,1805	0,2321	0,2708	0,3095	0,3481	0,3868

PULLEYS (for more details see our pulleys catalogue)

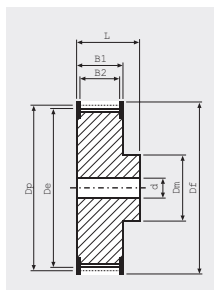

No. teeth	Dp	De	No. teeth	Dp	De
10	15,92	15,09	27	42,97	42,14
12	19,10	18,27	28	44,56	43,73
14	22,28	21,45	30	47,75	46,92
15	23,87	23,04	32	50,93	50,10
16	25,46	24,64	36	57,30	56,47
18	28,65	27,82	40	63,66	62,93
19	30,24	29,41	42	66,85	66,02
20	31,83	31,00	44	70,03	69,20
22	35,01	34,19	48	76,39	75,57
24	38,20	37,37	54	85,94	85,09
25	39,79	38,96	60	95,49	94,67
26	41,38	40,55			

*Available also without GAP

MEGAPOWER 2 T10 - T10DL

BELT CHARACTERISTICS

BELT WIDTH (mm)	10	12	16	20	25	32	50	75
PULLEY WIDTH B2 (mm)	15	17	21	25	30	37	56	80
BELT WEIGHT (gr/cm)	0,494	0,504	0,683	0,861	1,082	1,386	2,174	3,276

Standard compound: **Thermoset PU 88 ShA grey/green**

Standard cords: **Twisted Zinked Steel**

Standard belt width tolerance: **+/- 0,50 mm**

Standard sleeve width tolerance: **+/- 10 mm**

Standard thickness tolerance: **+/- 0,30 mm**

Special version belts on request, **see page 24**

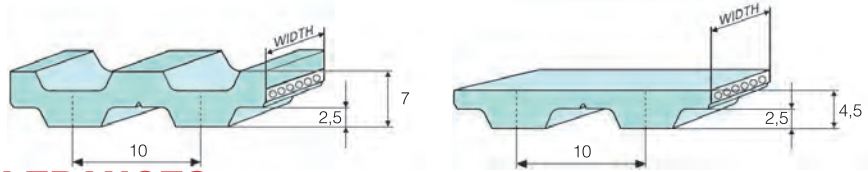
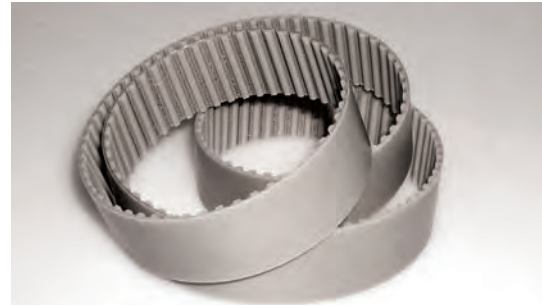

BELT LENGTHS AND TOLERANCES

Length (mm)	260	320	340	370	390	400	410	440	450	480	500	530	550	560	600*	610	630*	650	660	680	690
No. of teeth	26	32	34	37	39	40	41	44	45	48	50	53	55	56	60	61	63	65	66	68	69
Length tolerance (mm)	+/-0,32			+/-0,36			+/-0,42			+/-0,48											
Length (mm)	700	720*	730	750	780	800*	810	840	850	880	890	900*	910	920*	950	960	970	980	1000	1010	1050
No. of teeth	70	72	73	75	78	80	81	84	85	88	89	90	91	92	95	96	97	98	100	101	105
Length tolerance (mm)	+/-0,48						+/-0,56														
Length (mm)	1080	1100	1110	1140	1150	1200	1210	1240	1250	1300	1320	1350	1390	1400	1420	1440	1450	1460	1500	1560	
No. of teeth	108	110	111	114	115	120	121	124	125	130	132	135	139	140	142	144	145	146	150	156	
Length tolerance (mm)				+/- 0,64												+/- 0,76					
Length (mm)	1600	1610	1700	1750	1780	1800	1880	1960	2250												
No. of teeth	160	161	170	175	178		188	196	225												
Length tolerance (mm)				+/- 0,88			+/- 1,04														

DOUBLETOOTHED BELT LENGTHS

Length (mm)	260	530	630	660	700	720	800	840	900	920	980	1010	1100	1150	1210	1240	1250	1320	1350	1420	1500	1610	1800	1880
No. of teeth	26	53	63	66	70	72	80	84	90	92	98	101	110	115	121	124	125	132	135	142	150	161	188	
Length tolerance (mm)	+/-0,28	+/-0,42		+/-0,48			+/-0,56							+/-0,64				+/-0,76			+/- 0,88			

TRANSMITTABLE POWER (kW/cm of tooth in mesh)

n/z	12	14	16	18	20	22	24	26	28	30	36	48	54
100	0,0090	0,0104	0,0119	0,0134	0,0149	0,0164	0,0179	0,0194	0,0209	0,0224	0,0269	0,0358	0,0403
200	0,0166	0,0193	0,0221	0,0249	0,0276	0,0304	0,0331	0,0359	0,0387	0,0414	0,0497	0,0663	0,0746
600	0,0413	0,0482	0,0550	0,0619	0,0688	0,0757	0,0826	0,0894	0,0963	0,1032	0,1238	0,1651	0,1858
1000	0,0614	0,0717	0,0819	0,0922	0,1024	0,1126	0,1229	0,1331	0,1434	0,1536	0,1843	0,2458	0,2765
1500	0,0829	0,0967	0,1106	0,1244	0,1382	0,1520	0,1658	0,1797	0,1935	0,2073	0,2488	0,3317	0,3731
2000	0,1015	0,1184	0,1354	0,1523	0,1692	0,1861	0,2030	0,2200	0,2369	0,2538	0,3046	0,4061	0,4568
3000	0,1330	0,1551	0,1773	0,1994	0,2216	0,2438	0,2659	0,2881	0,3102	0,3324	0,3989	0,5318	0,5983
4000	0,1589	0,1854	0,2118	0,2383	0,2648	0,2913	0,3178	0,3442	0,3707	0,3972	0,4766	0,6355	0,7150
5000	0,1806	0,2107	0,2408	0,2709	0,3010	0,3311	0,3612	0,3913	0,4214	0,4515	0,5418	0,7224	0,8127
8000	0,2398	0,2798	0,3198	0,3597	0,3997	0,4397	0,4796	0,5196	0,5596	0,5995	0,7194		

PULLEYS (for more details see our pulleys catalogue)

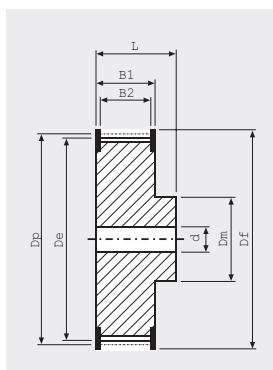

No. teeth	Dp	De	No. teeth	Dp	De
12	38,20	36,25	27	85,94	84,10
14	44,56	42,71	28	89,13	87,28
15	47,75	45,90	30	95,49	93,65
16	50,93	49,08	32	101,86	100,01
18	57,30	55,45	36	114,59	112,74
19	60,48	58,63	40	127,32	125,48
20	63,66	61,81	44	140,06	138,21
22	70,03	68,18	48	152,79	150,94
24	76,39	74,55	54	171,89	170,03
25	79,58	77,73	60	190,99	189,14
26	82,76	80,91			

*Available also without GAP

BELT CHARACTERISTICS

BELT WIDTH (mm)	6	8	10	12	16	20	25
PULLEY WIDTH B2 (mm)	12	13	15	17	21	25	30
BELT WEIGHT (gr/cm)	0,185	0,253	0,316	0,378	0,508	0,640	0,800

Standard compound: **Thermoset PU 88 ShA grey/green**

Standard cords: **Twisted Zinked Steel**

Standard belt width tolerance: **+/- 0,50 mm**

Standard sleeve width tolerance: **+/- 10 mm**

Standard thickness tolerance: **+/- 0,15 mm**

Special version belts on request, **see page 24**

S and Z torsion zinked steel on request

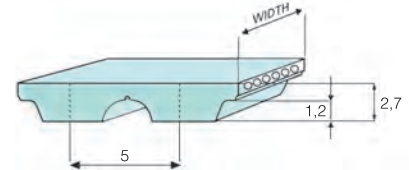

BELT LENGTHS AND TOLERANCES

Length (mm)	225	255	275	280	300	330	340	375	390	420	450	455	480	500	525	545	600	610	620	630	
No. of teeth	45	51	55	56	60	66	68	75	78	84	90	91	96	100	105	109	120	122	124	126	
Length tolerance (mm)	+/-0,28			+/-0,32			+/-0,36			+/-0,42											

Length (mm)	660	670	710	720	750	780	825	860	975	1050	1125	1500	2000
No. of teeth	132	134	142	144	150	156	165	172	195	210	225	300	400
Length tolerance (mm)	+/-0,48			+/-0,56			+/-0,64		+/-0,76		+/-1,04		

TRANSMITTABLE POWER (kW/cm of tooth in mesh)

n/z	12	14	16	18	20	22	24	26	28	32	44	60	68
100	0,0042	0,0049	0,0056	0,0063	0,0070	0,0077	0,0084	0,0091	0,0098	0,0112	0,0154	0,0210	0,0238
200	0,0080	0,0094	0,0107	0,0121	0,0134	0,0147	0,0161	0,0174	0,0188	0,0214	0,0295	0,0322	0,0456
600	0,0211	0,0246	0,0282	0,0317	0,0352	0,0387	0,0422	0,0458	0,0493	0,0563	0,0774	0,0845	0,1197
1000	0,0322	0,0375	0,0429	0,0482	0,0536	0,0590	0,0643	0,0697	0,0750	0,0858	0,1179	0,1286	0,1822
1500	0,0442	0,0515	0,0589	0,0662	0,0736	0,0810	0,0883	0,0957	0,1030	0,1178	0,1619	0,1766	0,2502
2000	0,0547	0,0638	0,0730	0,0821	0,0912	0,1003	0,1094	0,1186	0,1277	0,1459	0,2006	0,2189	0,3101
3000	0,0727	0,0848	0,0970	0,1091	0,1212	0,1333	0,1454	0,1576	0,1697	0,1939	0,2666	0,2909	0,4121
4000	0,0881	0,1028	0,1174	0,1321	0,1468	0,1615	0,1762	0,1908	0,2055	0,2349	0,3230	0,3523	0,4991
5000	0,1012	0,1180	0,1349	0,1517	0,1686	0,1855	0,2023	0,2192	0,2360	0,2698	0,3709	0,4046	0,5732
8000	0,1312	0,1530	0,1749	0,1967	0,2186	0,2405	0,2623	0,2842	0,3060	0,3498	0,4809	0,5246	0,7432

PULLEYS (for more details see our pulleys catalogue)

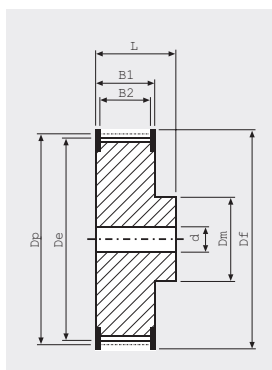

No. teeth	Dp	De	No. teeth	Dp	De
12	19,1	17,87	27	42,97	41,74
14	22,28	21,05	28	44,56	43,33
15	23,87	22,64	30	47,75	46,52
16	25,46	24,24	32	50,93	49,70
18	28,65	27,42	36	57,30	56,07
19	30,24	29,01	40	63,66	62,43
20	31,83	30,60	42	66,85	65,62
22	35,01	33,79	44	70,03	68,80
24	38,20	36,97	48	76,39	75,17
25	39,79	38,56	60	95,49	94,27
26	41,38	40,15	68	108,23	107,01

MEGAPOWER 2 AT10

BELT CHARACTERISTICS

BELT WIDTH (mm)	10	12	16	20	25	32	50	75
PULLEY WIDTH B2 (mm)	15	17	21	25	30	37	56	80
BELT WEIGHT (gr/cm)	0,578	0,707	0,952	1,184	1,469	1,905	3,005	4,344

Standard compound: **Thermoset PU 88 ShA grey/green**

Standard cords: **Twisted Zinked Steel**

Standard belt width tolerance: **+/- 0,50 mm**

Standard sleeve width tolerance: **+/- 10 mm**

Standard thickness tolerance: **+/- 0,30 mm**

Special version belts on request, **see page 24**

S and Z torsion zinked steel on request

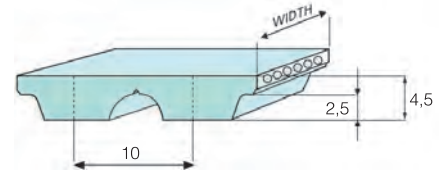

BELT LENGTHS AND TOLERANCES

Length (mm)	370	500	560	580	600	610	630	660	700	730	780	800	810	840	880	890	920	960	980	1000	1010
No. of teeth	37	50	56	58	60	61	63	66	67	73	78	80	81	84	88	89	92	96	98	100	101
Length tolerance (mm)	+/-0,32	+/-0,36				+/-0,42			+/-0,48						+/-0,56						+/-0,64

Length (mm)	1050	1080	1100	1150	1190	1200	1210	1220	1230	1240	1250	1280	1300	1320	1350	1360	1400	1420	1480	1500
No. of teeth	105	108	110	115	119	120	121	122	123	124	125	128	130	132	135	136	140	142	148	150
Length tolerance (mm)	+/-0,64										+/-0,76									

Length (mm)	1600	1630	1700	1720	1800	1860	1940
No. of teeth	160	163	170	172	180	186	194
Length tolerance (mm)	+/-0,88						

TRANSMITTABLE POWER (kW/cm of tooth in mesh)

n/z	15	18	20	22	24	26	28	30	38	42	48	54	60
100	0,0215	0,0257	0,0286	0,0315	0,0343	0,0372	0,0400	0,0429	0,0543	0,0601	0,0686	0,0772	0,0858
200	0,0407	0,0488	0,0542	0,0596	0,0650	0,0705	0,0759	0,0813	0,1030	0,1138	0,1301	0,1463	0,1626
600	0,1041	0,1249	0,1388	0,1527	0,1666	0,1804	0,1943	0,2082	0,2637	0,2915	0,3331	0,3748	0,4164
1000	0,1547	0,1856	0,2062	0,2268	0,2474	0,2681	0,2887	0,3093	0,3918	0,4330	0,4949	0,5567	0,6186
1500	0,2076	0,2491	0,2768	0,3045	0,3322	0,3598	0,3875	0,4152	0,5259	0,5813	0,6643	0,7474	0,8304
2000	0,2520	0,3024	0,3360	0,3696	0,4032	0,4368	0,4704	0,5040	0,6384	0,7056	0,8064	0,9072	1,0080
3000	0,3239	0,3886	0,4318	0,4750	0,5182	0,5613	0,6045	0,6477	0,8204	0,9068	1,0363	1,1659	1,2954
4000	0,3788	0,4545	0,5050	0,5555	0,6060	0,6565	0,7070	0,7575	0,9595	1,0605	1,2120	1,3635	1,5150
5000	0,4220	0,5063	0,5626	0,6189	0,6751	0,7314	0,7876	0,8439	1,0689				
8000	0,4950	0,5940	0,6600	0,7260	0,7920	0,8580	0,9240	0,9900					

PULLEYS (for more details see our pulleys catalogue)

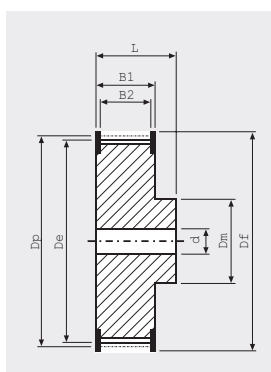

No. teeth	Dp	De	No. teeth	Dp	De
15	47,75	45,90	30	95,49	93,65
16	50,93	49,08	32	101,86	100,01
18	57,30	55,45	36	114,59	112,74
19	60,48	58,63	38	120,96	119,14
20	63,66	61,81	40	127,32	125,48
22	70,03	68,18	42	133,69	131,87
24	76,39	74,55	44	140,06	138,21
25	79,58	77,73	48	152,79	150,94
26	82,76	80,91	54	171,89	170,07
27	85,94	84,10	60	190,99	189,14
28	89,13	87,28			

BELT CHARACTERISTICS

PITCH	H	L	T5	T5DD	T10	T10DD	AT10
For profile shape and dimensions tolerances see previous pitches profile pages							

Standard compound: **Thermoset PU 88 ShA dark blue** RAL 5002
 cords: **Z Twisted stainless Steel AISI 304**
 Teeth cover (NFT): **Not available**
 Back cover: **Not available**
 Thermal working range (C°): **- 25 / + 80**
 Thermal working range tolerance (C°): **+/- 5**
 Food contact features (materials components): **Produced and certified according EU 10/2011 and 174/2015 with food contact approved components**



Tooth shear resistance 25 % less of values declared on previous pitches pages
 Transmittable power 25 % less of values declared on previous pitches pages

CHEMICAL RESISTANCE

*Chemical agent	Tap water	Sea water	Mineral oil/grase	Syntetic oil/grease	Strong acids	Strong alkali	Solvent/fuels	Outdoor ageing
Concentration %	pure	pure	pure	pure	max 3%	max 30%	pure	n.a.
Temperature (C°)	max 60°	max 60°	max 60°	max 60°	max 40°	max 40°	r.t.	-25°/+80°
Belt body resistance	very good	good	good	medium	good	good	medium	very good
Cord insert resistance	very good	good	very good	very good	medium good	medium good	good	good

*Chemical are too wide range and general rules are not always valid. In case of any doubt please contact our technical team.

KEY FEATURES AND BENEFITS

- Good chemical resistance
- Good corrosion resistance
- Good humidity and hydrolysis resistance
- Inox cords
- Food contact approved components
- Special designs for food conveyance on request
- Additional backing profiles to evaluate on request

Food contact features (materials components): Produced with food contact approved components according to European regulations EU 1935/2004, EU 10/2011 and subsequently updates according to EU 174/2015.

MEGAPOWER FEASIBILITY TABLE

	MXL	XL	L	H	T2	T2,5	T5	T10	T5DL	T10DL	AT5	AT10
Min no. teeth pulley st. cords	10	10	15	14	10	10	10	12	10	12	15	15
Min outside idler dia	18	30	60	80	18	18	30	60	30	60	60	120
Min inside idler dia	20	30	60	60	20	20	30	60	30	60	25	50
Min no. teeth pulley HF cords	-	-	-	-	-	-	10	12	10	12	12	15
Min outside idler dia	-	-	-	-	-	-	30	50	30	50	40	80
Min inside idler dia	-	-	-	-	-	-	30	50	30	50	25	50
Min no. teeth pulley HP cords	-	-	-	-	-	15	15	15	-	-	25	25
Min outside idler dia	-	-	-	-	-	30	40	100	-	-	60	150
Min inside idler dia	-	-	-	-	-	30	60	100	-	-	40	80
Min no. teeth pulley HPF cords	-	-	-	-	-	-	12	14	-	-	20	16
Min outside idler dia	-	-	-	-	-	-	30	80	-	-	40	100
Min inside idler dia	-	-	-	-	-	-	30	80	-	-	40	60
Min no. teeth pulley kevlar cords	12	10	15	14	12	12	12	15	12	15	15	15
Min outside idler dia	20	30	60	80	20	20	30	60	30	60	60	120
Min inside idler dia	20	20	60	60	20	20	30	60	30	60	25	50
Min no. teeth pulley fiberglass cords	-	13	18	18	-	-	15	15	-	-	-	-
Min outside idler dia	-	35	65	90	-	-	40	70	-	-	-	-
Min inside idler dia	-	35	65	65	-	-	40	70	-	-	-	-
Min no. teeth pulley polyester cords	12	10	-	-	-	12	12	-	-	-	-	-
Min outside idler dia	20	30	-	-	-	20	30	-	-	-	-	-
Min inside idler dia	20	20	-	-	-	20	30	-	-	-	-	-
Min no. teeth pulley stainless steel cords	-	13	18	18	-	-	15	15	15	15	15	19
Min outside idler dia	-	35	65	80	-	-	40	70	40	70	65	110
Min inside idler dia	-	35	65	65	-	-	40	70	40	70	60	110
Steel cords	O	O	O	O	O	O	O	O	O	O	O	O
High Flexibility cords	X	X	X	X	X	X	M	M	M	M	M	M
High Performance cords	X	X	X	X	X	M	M	M	X	X	M	M
High Performance Flexibility	X	X	X	X	X	X	M	M	X	X	M	M
Kevlar cords	R	R	R	M	M	M	M	M	M	M	M	M
Fiberglass cords	X	R	M	M	X	X	M	M	X	X	X	X
Polyester cords	M	M	X	X	M	M	M	X	X	X	X	X
Stainless steel cords	X	M	M	M	X	X	M	M	M	M	M	M
Pu yellow coating 50 ShA cover	M	M	M	M	M	M	M	M	X	X	M	M
Porol mousse 10 ShA cover	M	M	M	M	M	M	M	M	X	X	M	M
Linatex 42 ShA cover	M	M	M	M	M	M	M	M	X	X	M	M
Tenax 40 / 45 ShA cover	M	M	M	M	M	M	M	M	X	X	M	M
White alimentary rubber 70 ShA cover	M	M	M	M	M	M	M	M	X	X	M	M
Neoprene rubber 70 ShA cover	M	M	M	M	M	M	M	M	X	X	M	M
Gummy correx 48 ShA cover	M	M	M	M	M	M	M	M	X	X	M	M
NBR 70 ShA cover	M	M	M	M	M	M	M	M	X	X	M	M
Hypalon 60 ShA cover	M	M	M	M	M	M	M	M	X	X	M	M
Honey comb 45 ShA cover	M	M	M	M	M	M	M	M	X	X	M	M
FDA compound	M	M	M	M	M	M	M	M	M	M	M	M

O = Ex stock
 R = On request without minimum quantity

M = On request with minimum quantity
 X = Not available

COATINGS AND COVER PROPERTIES

Megapower timing belts can be coated with several materials on the back side to obtain specific properties required (higher friction coefficient, higher abrasion resistance, higher oil resistance, etc.).

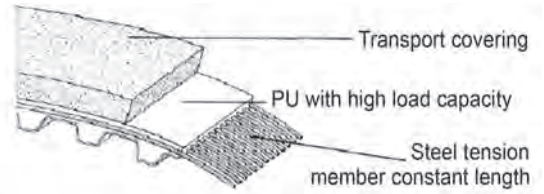

	Cover type										
	Porol mousse	Linatex	Tenax 40	Tenax Standard	White Rubber for food industry	Neoprene	Gummy Correx ambraparlond	NBR	Hypalon	Honeycomb	Foamed polyurethane
Raw material	open cell neoprene rubber	natural rubber	natural rubber	natural rubber	synthetic rubber	synthetic rubber	natural rubber	nitrilic rubber	rubber	natural rubber	foamed polyurethane
Hardness (ShA)	10	42	40	45	70	70	48	70	60	45	50
Colour	black	red	red	red	white	gray/black	light brown	white	white	red	yellow/gray
Coating and belt cohesion method	by gluing	by gluing	by vulcanization	by vulcanization	by vulcanization	by vulcanization	by vulcanization	by vulcanization	by vulcanization	by gluing	by spray
Thickness range (mm)	2 till 15	0,8 till 15	0,8 till 15	0,8 till 15	0,8 till 15	0,8 till 15	0,8 till 15	0,8 till 15	0,8 till 15	4,5	0,5 till 8
Tolerance on coating thickness	+/-0,3	+/-0,3	+/-0,3	+/-0,3	+/-0,3	+/-0,3	+/-0,3	+/-0,3	+/-0,3	+/-0,5	+/-0,3
Working temperature range (°C)	-10 / +60	-20 / +50	-20 / +60	-20 / +60	0 / +120	-10 / +100	-20 / +60	0 / +120	0 / +160	-20 / +60	-20 / +60
Friction coefficient ⁽¹⁾	0,7	0,75	0,75	0,7	0,65	0,6	0,6	0,6	0,6	0,6	0,4
Water resistance	good	very good	very good	very good	good	very good	very good	good	good	very good	good
Abrasion resistance	intermediate	very good	very good	very good	intermediate	good	very good	intermediate	intermediate	very good	very good
Oil resistance	intermediate	low	low	low	good	good	low	good	good	low	very good
FDA approved	no	no	no	no	no	no	no	no	no	no	no
Min. pulley dia 5 coating thickness fl ... ⁽²⁾	x 25	x 30	x 30	x 30	x 35	x 35	x 30	x 35	x 35	x 30	x 25

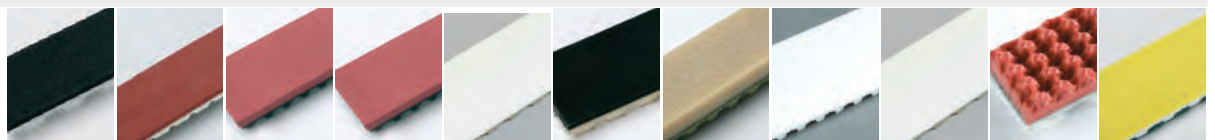

(1) Static Average values for steel guides

(2) Suggested diameter is bigger value between this calculated value and minimum pulley diameter on belt data page

SPECIAL EXECUTIONS

COLOUR

On customer request and with a minimum quantity it is possible to produce Megapower with several colours. Different colour doesn't influence belt technical properties so mechanical features are same as standard grey/green belt.

MECHANICAL REWORK

Megadyne have been producing specialized belting for many years. Our in-house facilities enable us to produce belts with special holes for vacuum applications, belts with special backings/grounds finishes for high tolerance applications. We can remove individual teeth and perforate the timing belt as required.

BACK GRINDING

A belt back can be ground to achieve a precise belt thickness as an adjunct to precision drives. When belt back grinding to a tolerance is required, the total thickness, including the tooth, must be specified. A grinding tolerance of +/- 0,2 mm is achievable with a level finish (i.e. thickness will not vary greatly around the belt).

LONGITUDINAL REWORK

Longitudinal rework along the belt back is possible on covered and uncovered belts. The profile can be machined precisely for required function. The measurement is given as the depth on the belt back. Most widths and lengths are available.

REWORK ON BELT TEETH

The rework of the tooth profile can be very useful, i.e. improving the steering effect with guide rails. The rework dimension is given from the top of the tooth.

HOLES IN TIMING BELTS

Holes in timing belts can be for vacuum or air film conveying or as clearance for assembly mechanisms. Stops and cams can be attached through the holes. Customized tooling may be required depending on the layout and dimensions of holes required.

ANTISTATIC\ELECTRICAL CONDUCTIVE BELTS (MEGAPOWER EC)

On customer request and with minimum quantity, it is possible to produce antistatic\electrical conductive Megapower belts complies with ISO 9563 standard, and limited to the following configuration with respect standard belts:

- 89 +/- 4 ShA special grade polyurethane, black colour (RAL 9011 reference)
- Transmittable power and tooth resistance 25 % less of values declared for standard version

SINGLE TOOTH REMOVAL

Single and multiple tooth removal is available to your requirement, for applications in handling and conveying technology

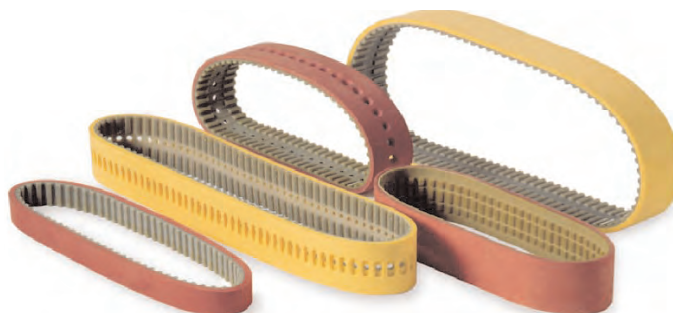

Belts and sleeves

Customer can choose the right Megapower depending on his business features: belts are finished and ready to use, while sleeves can be stored and cut at requested width by end-users

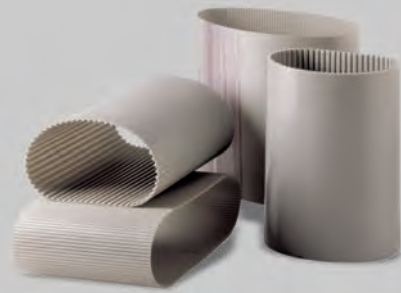

Special profiles

Megapower belts can be manufactured on customer request also with pitch T2, RPP3, RPP8, STD3, MTD5



AT20 for high power

Megapower belts are available also in AT20 pitch, with standard or special cords, to work in very high power transmission applications



Directly moulded special cleats

Special cleats and flat profiles can be directly moulded with the belt, being a part of it and giving higher mechanical characteristics

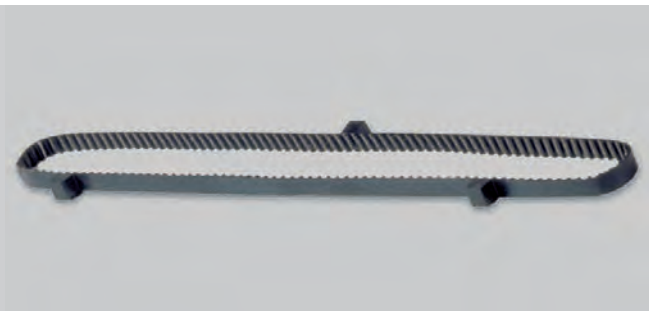

Tracking belts for lifts

Custom design moulded belt, with high strength capacity and helical special teeth, high coefficient of friction and very low noise level, used as tracking belts in lift applications



SPECIAL EXECUTIONS PHOTOS

Vacuum applications

Megapower belts for vacuum applications, coated with Tenax or other coatings, with ground teeth, holes and slots (perpendicular or sloping) for vacuum transmission



Packing industry

Particular Megapower with directly moulded carriers and pushers, engineered to meet very special customer requests

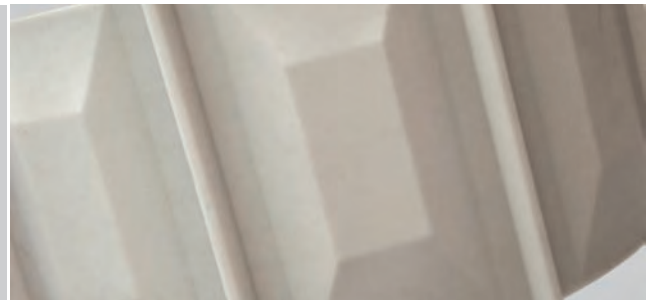

Special carriers

Megapower customised belt with directly moulded carriers, developed following customer design



Office automation

Megapower belt with special moulded cleats, typically used in office automation and printing machines



Carding machines

Special moulded belt with cylindrical cleats, used in textile industry

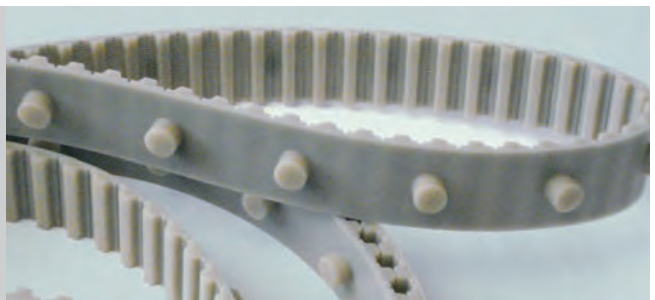

Textile industry

Special moulded belt used in textile industry, manufactured in red or in blue polyurethane

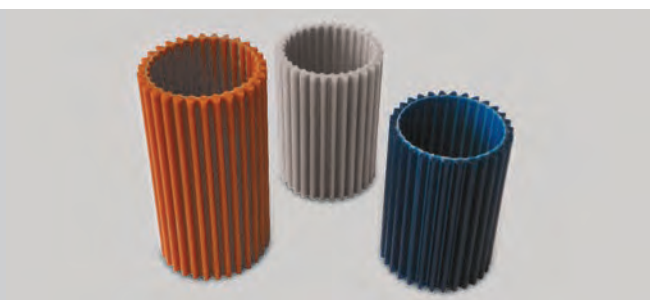

PULLEYS AND TIMING BARS



PULLEYS AND TIMING BARS

Pulleys can be provided both in standard design, according to ISO specifications, and engineered on customer requests.

Manufactured in aluminium, steel and cast iron, Megadyne pulleys are available with or without steel flanges and surface treatment.

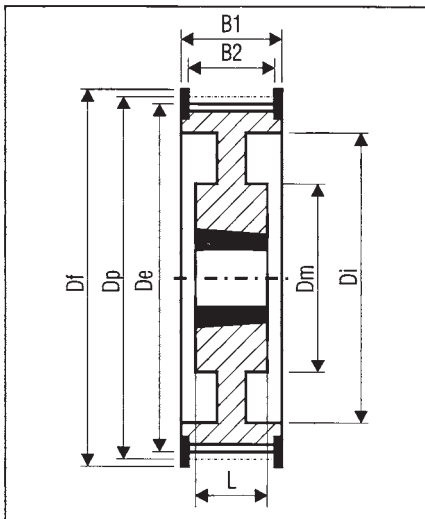
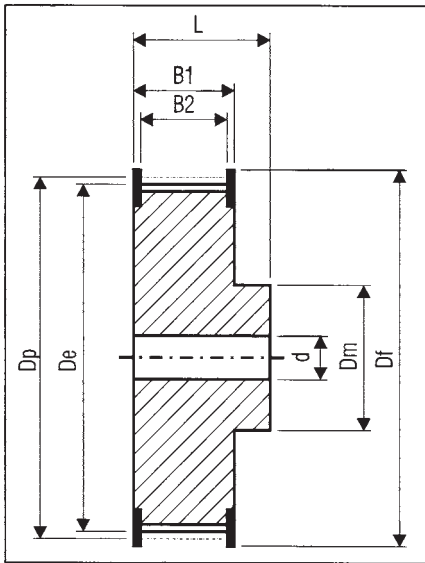
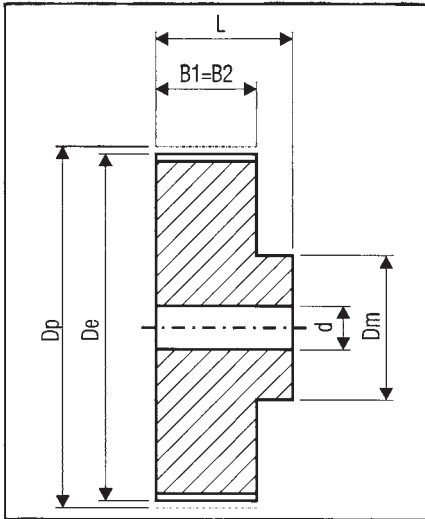

Imperial	MXL - XL - L - H - XH - XXH - HG
HTD	3M - 5M - 8M - 14M
METRIC	T2,5 - T5 - T10 - T20 - AT3 - AT5 - AT10 AT20 - TG5 - TG10 - TG20 - ATG10
RPP	RPP5 - RPP8 - RPP14

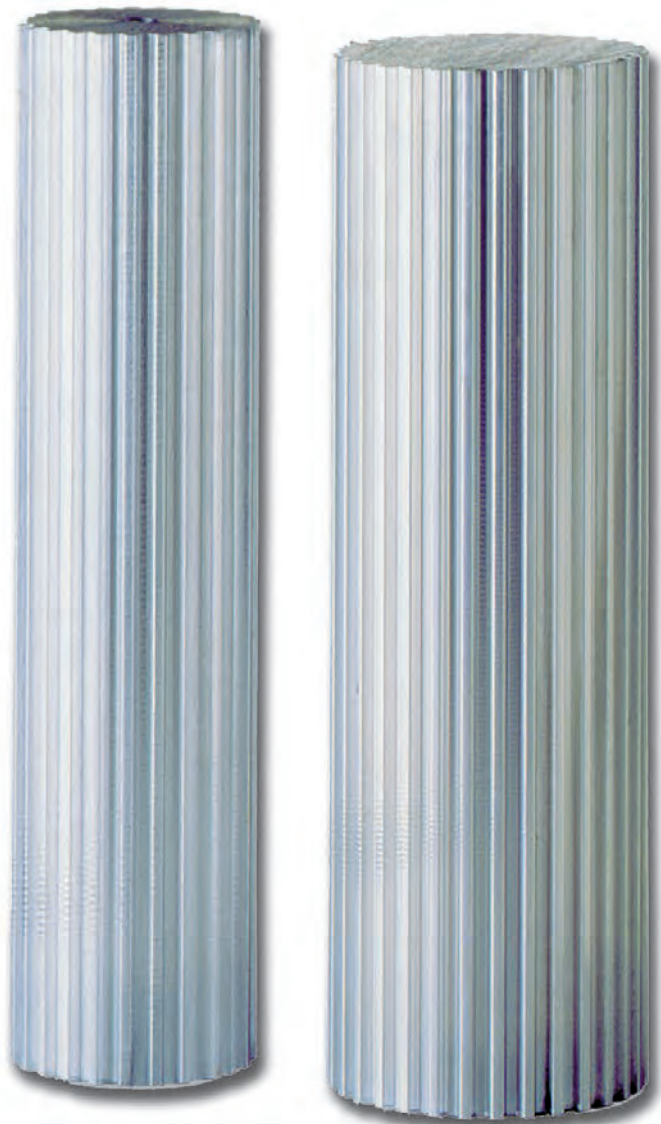

USEFUL FORMULAS AND CONVERSION TABLE

SPEED

$$V = \frac{d_1 \cdot n_1}{19100}$$

$$n_1 = \frac{V \cdot 19100}{d_1}$$

$$d_1 = \frac{V \cdot 19100}{n_1}$$

V: peripheral speed [m/s]
n₁: rotation speed [RPM]
d₁: pulley diameter [mm]

FORCES AND TORQUE

$$F_u = \frac{19,1 \cdot 10^6 \cdot P}{d_1 \cdot n_1}$$

$$F_u = \frac{2000 \cdot M}{d_1}$$

$$F_u = \frac{P \cdot 10^3}{d_1}$$

F_u: peripheral force [N]
M_t: drive torque [Nm]
P: power [kW]
n₁: rotation speed [RPM]
d₁: pulley diameter [mm]
V: peripheral speed [m/s]

$$M_t = \frac{P \cdot 9550}{n_1}$$

$$M_t = \frac{F_u \cdot d_1}{2000}$$

$$M_t = \frac{P \cdot d_1}{2 \cdot V}$$

SPEED

$$P = \frac{F_u \cdot d_1 \cdot n_1}{19,1 \cdot 10^6}$$

$$P = \frac{M_t \cdot n_1}{9550}$$

$$P = \frac{F_u \cdot V}{1000}$$

P: power [kW]
F_u: peripheral force [N]
M_t: drive torque [Nm]
n₁: rotation speed [RPM]
d₁: pulley diameter [mm]

To convert from	To	Multiply by
CV	HP	0,9863201
CV	kcal/h	63,24151
CV	W	735,4988
CV	kW	0,7354988
CV	kgf ⇔ m/s	75
CV	lbf ⇔ ft/s	542,476
HP	CV	1,01387
HP	kcal/h	641,1865
HP	W	745,6999
HP	kW	0,7456999
HP	kgf ⇔ m/s	76,04022
HP	lbf ⇔ ft/s	550
in	m	0,0254
in	cm	2,54
in	mm	25,4
in	ft	0,083
in ²	m ²	0,00064516
in ²	cm ²	6,4516
in ²	mm ²	645,16
in ²	ft ²	0,006944444
in ³	m ³	1,63871 · 10 ⁻⁵
in ³	cm ³	16,38706
in ³	mm ³	16387,06
in ³	ft ³	0,000578704

To convert from	To	Multiply by
J	CV ⇔ h	3,77673 · 10 ⁻⁷
J	HP ⇔ h	3,72506 · 10 ⁻⁷
J	kWh	2,77778 · 10 ⁻⁷
kg	lb	2,204623
kgf	N	9,80665
kgf	lbf	2,204623
kgf ⇔ m/s	CV	0,01333333
kgf ⇔ m/s	W	9,80665
kgf ⇔ m/s	kW	0,00980665
kW	CV	1,359622
kW	kcal/h	859,8452
kW	W	1000
kW	kgf ⇔ m/s	101,9716
kW	lbf ⇔ ft/s	737,5621
lb	kg	0,4535924
lb	kgf	0,4535924
lb	N	4,448222
N	kgf	0,1019716
N	lbf	0,2248089
W	CV	0,001359622
W	HP	0,001341022
W	kcal/h	0,8598452
W	kW	0,001
W	kgf ⇔ m/s	0,1019716
W	lbf ⇔ ft/s	0,7375621

CUSTOMER DATA

Date ____/____/____

Company Name _____
 Address _____ Zip Code _____
 City _____ State _____ Country _____
 Customer Name/Surname _____
 Office _____ Tel. _____ Fax _____
 e-mail _____

DRIVE INFORMATION TRANSMISSION LAYOUT

Power transmission

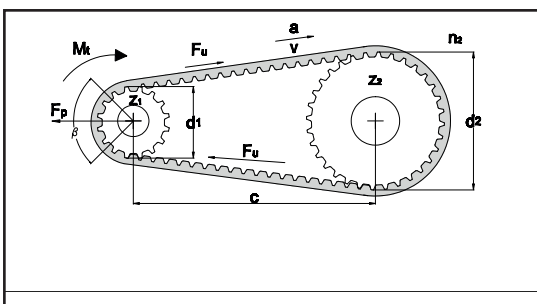

Conveyor

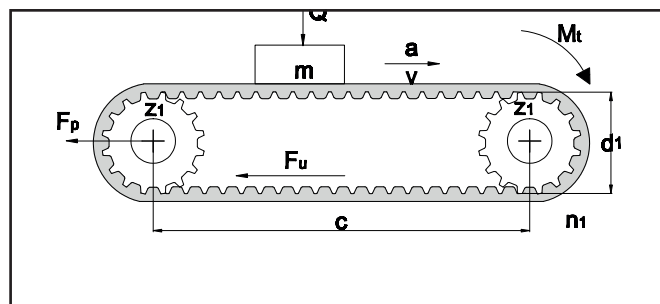

Other (If layout is different please sketch it below)

DRIVE INFORMATION (FOR POWER TRANSMISSION)

MOTOR:

AC DC Soft Start Inverter
 Power: _____
 Speed: _____
 Torque: _____
 Acceleration: _____
 Working time: < 8h From 8h up to 16h 24h

APPLICATION:

Driver pulley 's diameter: _____
 Driven pulley's diameter: _____
 Center distance: _____
 Minimum safety factor needed: _____
 Are there any size limitation? Yes No
 (if yes please indicate):
 Max diameter: _____

 Max width: _____
 Max center distance: _____

DATA SHEET

DRIVE INFORMATION (FOR CONVEYOR)

APPLICATION:

Driver pulley 's diameter: _____

Driven pulley's diameter: _____

Center distance: _____

Minimum safety factor needed: _____

Are there any size limitation? Yes No
(if yes please indicate):

Max diameter: _____

Max width: _____

Max center distance: _____

Linear speed: _____

Acceleration: _____

Mass: _____

Is there any sliding surface? Yes No
(if yes please indicate friction coefficient):

Is there any cover on the back? Yes No
(if yes please indicate the type)

Are cleats required? Yes No
(if yes please indicate cleats code, otherwise attach
drawings)

Working time: < 8h From 8h up to 16h 24h

WORK'S ENVIRONMENT INFORMATION (FOR ALL LAYOUT TRANSMISSION SYSTEM)

Work Temperature (please indicate constant temperature and in case peaks):

Humidity: Standard No standard Other _____

Chemical agents: (oils , grass , aggressive compounds)
 Yes No

In case please indicate type and percentage:

NOTE:

Send us this form to:

Fax: +39 011-9268487

Adress: MEGADYNE SPA - Via trieste 16, 10075, Mathy, ITALY
or by e-mail: info@megadynegroup.com

Signature: _____

CUSTOMER DATA

Date ___/___/___

Company Name _____
 Address _____ Zip Code _____
 City _____ State _____ Country _____
 Customer Name/Surname _____
 Office _____ Tel. _____ Fax _____
 e-mail _____

DRIVE INFORMATION TRANSMISSION LAYOUT

Power transmission

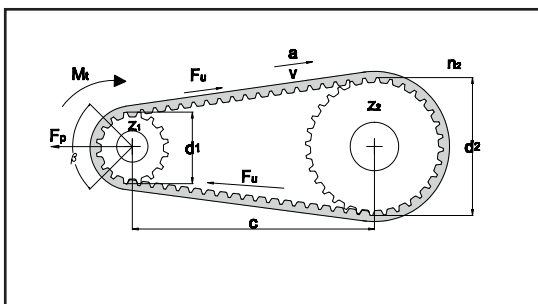

Conveyor

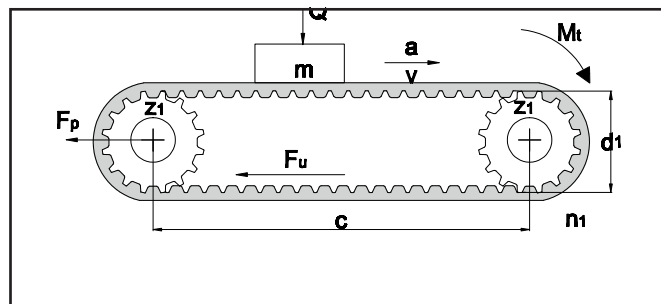

Other (If layout is different please sketch it below)

DRIVE INFORMATION (FOR POWER TRANSMISSION)

MOTOR:

AC DC Soft Start Inverter
 Power: _____
 Speed: _____
 Torque: _____
 Acceleration: _____
 Working time: < 8h From 8h up to 16h 24h

APPLICATION:

Driver pulley 's diameter: _____
 Driven pulley's diameter: _____
 Center distance: _____
 Minimum safety factor needed: _____
 Are there any size limitation? Yes No
 (if yes please indicate):
 Max diameter: _____

 Max width: _____
 Max center distance: _____

DATA SHEET

DRIVE INFORMATION (FOR CONVEYOR)

APPLICATION:

Driver pulley 's diameter: _____
Driven pulley's diameter: _____
Center distance: _____
Minimum safety factor needed: _____
Are there any size limitation? Yes No
(if yes please indicate):
 Max diameter: _____
 Max width: _____
 Max center distance: _____
Linear speed: _____
Acceleration: _____
Mass: _____

Is there any sliding surface? Yes No
(if yes please indicate friction coefficient):

Is there any cover on the back? Yes No
(if yes please indicate the type)

Are cleats required? Yes No
(if yes please indicate cleats code, otherwise attach drawings)

Working time: < 8h From 8h up to 16h 24h

WORK'S ENVIRONMENT INFORMATION (FOR ALL LAYOT TRANSMISSION SYSTEM)

Work Temperature (please indicate constant temperature and in case peaks):

Humidity: Standard No standard Other _____

Chemical agents: (oils , grass , aggressive compounds)
 Yes No

In case please indicate type and percentage:

NOTE:

Send us this form to:
Fax: +39 011-9268487
Adress: MEGADYNE SPA - Via trieste 16, 10075, Mathy, ITALY
or by e-mail: info@megadynegroup.com

Signature: _____

The data and information contained in the present catalogue are up-to-dated to the date of the catalogue's printing. Megadyne Spa reserves the right to modify the specifications, performances and other information relating to the belts described in the present catalogue, at any time at its own discretion, without any prior notice.

For updating refer to our web site www.megadynegroup.com.

Technical specifications, performances and other information provided in the present catalogue are indicative and do not bound Megadyne unless such specifications, performances or other information are expressly agreed in the agreement with the customer.

We also recommend to read carefully the following documents in our web site www.megadynegroup.com:

- Megadyne General Conditions of Sale (comprising the warranty)
- Theoretical Belt Life
- Drive Components: Storage, Installation, Maintenance and Troubleshooting Handbook
- Belts standard use condition and temperature.

Copyright Notice: Megadyne Spa copyright. All rights reserved. Megadyne is and shall remain the owner of all rights on drawings, technical specifications and any other information contained in the present catalogue or otherwise communicated by Megadyne Spa to the customer. The customer shall not disclose such information to third parties or use such information for purposes different from the definition of the order to Megadyne Spa, unless upon prior written authorization of Megadyne.



Megadyne S.p.A.
Italy - MATHI

AUSTRALIA

Melbourne
Phone +61 (03) 9763 6701
aussales@challengept.com

BELARUS

Minsk
Phone +375 17 2802486
Info.by@megadynegroup.com

BRASIL

Sorocaba
Phone +55 15 2101 7700
Info.br@megadynegroup.com

CANADA

Edmonton
Phone +1 780 461 4400
Info.ca@megadynegroup.com

Montreal

Phone +1 514 31 2341
Info.ca@megadynegroup.com

Toronto

Phone +1 905 602 4400
Info.ca@megadynegroup.com

CHINA

Beijing
Phone +86 10 8150 7478
info.cn@megadynegroup.com

Foshan

Phone +86 757 8381 5530
info.cn@megadynegroup.com

Ningbo*

Phone +86 574 8650 5008
info.cn@megadynegroup.com

Phone +86 574 8833 4378
sales@challengept.com

Qingdao*

Phone +86 532 8658 0951
info.cn@megadynegroup.com

Shanghai

Phone +86 21 5447 1473
info.cn@megadynegroup.com

Xi'an

Phone +86 29 86358108
info.cn@megadynegroup.com

COLOMBIA

Bogotá
Phone +57 (1) 471 0503
Phone +57 (1) 893 9890
Info.co@megadynegroup.com

Cartagena

Phone +57 (5) 669 3604
Info.co@megadynegroup.com

CZECH REPUBLIC

Prague
Phone +420 2 8481 7181
Info.cz@megadynegroup.com

FRANCE

Paris
Phone +33 1 6079 8200
info.fr@megadynegroup.com

GERMANY

Borchen
Phone +49 5251 8735 0
info.de@megadynegroup.com

HUNGARY

Budapest
Phone +36 23 428 628
info.hu@megadynegroup.com

INDIA

Chennai*
Phone +91 98841 81175
info.in@megadynegroup.com

IRELAND

Dublin
Phone +353 1 456 6311
ireland@challengept.com

ISRAEL

Caesarea
Phone +972 4 6371485
sales@megabelt.co.il

ITALY

Turin*
Phone +39 011 926 8052
info@megadynegroup.com

Pescara*

Phone +39 085 9700547
info.it@megadynegroup.com

Venice

Phone +39 041 929 367
info.it@megadynegroup.com

JAPAN

Nagoya
Phone +81 52 433 7400
info.jp@megadynegroup.com

MEXICO

Mexico C.P.
Phone +52 55 5587 3680
info.mx@megadynegroup.com

PERU

Lima
Phone +51 713 0069
info.pe@megadynegroup.com

POLAND

Bielsko Biala
Phone +48 32 447 7179
info.pl@megadynegroup.com

Bydgoszcz*

info.pl@megadynegroup.com

SINGAPORE

Singapore
Phone +65 62739767
Info.sg@megadynegroup.com

SOUTH AFRICA

Johannesburg
Phone +27 (0) 12 661 1652
info.za@megadynegroup.com
Phone +27 (0) 11 3976115
sasales@challengept.com

Cape Town

Phone +27 (0)21 9820772
info.za@megadynegroup.com

SOUTH KOREA

Gyeonggi-do
Phone +82 314483613-7
Info.kr@megadynegroup.com

SPAIN

Vilanova*
Phone +34 93 811 5450
info.es@megadynegroup.com

SWEDEN

Kristianstad
Phone +46 10 1309600
info.se@megadynegroup.com

THAILAND

Bangkok
Phone +66 966 207648
info.th@megadynegroup.com

TURKEY

Izmir
Phone +90 232 877 07 00
info.tr@megadynegroup.com

U.K.

Birmingham
Phone +44 1384 215 021
info.uk@megadynegroup.com

Wolverhampton

Phone +44 (0) 1902 866116
uksales@challengept.com

U.S.A

California
Phone +1 323 265 8061
info.us@megadynegroup.com

Florida

Phone +1 813 241 4111
info.us@megadynegroup.com

Georgia*

info.us@megadynegroup.com

Illinois

Phone +1 630 752 0600
info.us@megadynegroup.com

New Jersey Americas HQ

Phone +1 973 227 4904
info.us@megadynegroup.com

North Carolina*

info.us@megadynegroup.com

Oregon

Phone +1 503 231 7224
info.us@megadynegroup.com

Texas

Phone +1 972 438 6992
info.us@megadynegroup.com

*** Manufacturing locations****GENERAL CONTACT INFORMATION**

MEGADYNE
Via S. Lucia, 114
10075 Mathi (Torino)

Phone +39 011 926 8052
info@megadynegroup.com

ammega.com