



**POWER TRANSMISSION
RIGID COUPLINGS**

CLAMP AND FLANGE COUPLINGS



CLAMP AND FLANGE COUPLINGS

FLANGE COUPLINGS DIN 116

Flange couplings are torsionally stiff, particularly sturdy and reliable shaft connections which can withstand jolts and radially or axially acting loads. The connected shafts must be precisely aligned. The flange couplings form C are equipped with a hollow for axial thrust washers according to DIN 28135 (applied, for example, with vertical agitator shafts). Axial thrust washers are not supplied and must be ordered separately. The connection dimensions of the flange couplings are in accordance with DIN 116, the centring of the coupling parts is achieved, however, only by means of fitting bolts. Normal design with feather key groove according to DIN 6885/1. Key slot according to DIN 6886 or DIN 6887 on request. In the case of shaft connections with different shaft diameters the coupling size assigned to the largest shaft diameter is used (reducing coupling).

- > Horizontal arrangement: form A
- > Vertical arrangement: form C
- > Material: normal design EN-GJL according to DIN EN 1561. On request in steel up to size 100 and in cast steel from size 110.

CLAMP COUPLINGS DIN 115

Clamp couplings are torsionally stiff and reliable shaft connections which can withstand jolts and radially or axially acting loads. The connected shafts must be precisely aligned. With the two shells which are bolted together the couplings are very easy to assemble and are therefore ideally suitable for shafts connected in series (e. g. transmission shafts).

When connecting shafts with different diameters we recommend that the thicker shaft end be offset on the diameter of the thinner one. If this is not possible the model with offset hole corresponding to the larger shaft diameter is used (form B). Clamp couplings can also be supplied with a protective jacket of sheet steel (form AS; BS or CS). All clamp couplings have feather key groove according to DIN 6885/1.

- > Horizontal arrangement:
 - Form A for shaft ends with same diameters
 - Form B for shaft ends with different diameters



- > Clamp couplings DIN 115
- > Flange couplings DIN 116
- > Clamp couplings 2-piece design
- > Clamp couplings 1-piece design

- > Vertical arrangement:
 - Form A with suspension key according to DIN 28134
 - Form C with ring inserts according to DIN 115 Sheet 2
- > Material: normal design EN-GJL according to DIN EN 1561. GS-45 on request.

PLEASE NOTE:

For shaft connections with rigid couplings the shafts must be precisely aligned. In order to avoid any excessive bending load on the coupling bearing must be mounted on both sides of the coupling where long shafts or high rotational speeds are involved.

CLAMP COUPLING 1-PIECE DESIGN

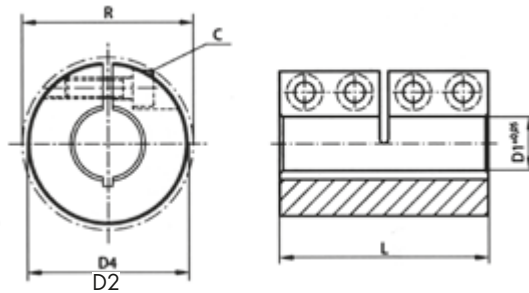

CLAMP COUPLING 2-PIECE DESIGN

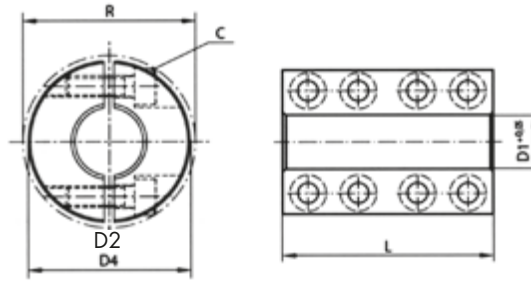

> Material, design: steel 1.0718, black-oxidized; stainless steel 1.4305, blank

STEEL / STAINLESS STEEL

Size D1	Nominal torque	Nominal torque	Dimensions in mm			C DIN 912-12.9	Weight ca. kg
	Steel Nm	Stainless steel Nm	D2	L	R		
8	50	16	24	35	26.8	M3 x 8	0.10
10	85	25	29	45	32.7	M4 x 12	0.19
12	105	32	29	45	32.7	M4 x 12	0.18
14	160	40	34	50	39.1	M5 x 16	0.27
15	180	50	34	50	39.1	M5 x 16	0.27
16	200	60	34	50	39.1	M5 x 16	0.26
19	300	90	42	65	48.2	M6 x 18	0.52
20	350	100	42	65	48.2	M6 x 18	0.52
25	400	110	45	75	50.8	M6 x 18	0.62
30	475	150	53	83	58.1	M6 x 18	0.92
35	1100	330	67	95	74.1	M8 x 25	1.88
40	1325	400	77	108	83.4	M8 x 25	2.71
50	2250	688	85	124	93.2	M10 x 25	3.52

> Wear- and maintenance-free
 Max. rotational speed: 4000 rpm
 Temperature range: -40°C to +175°C
 On request: other dimensions, design with keyway according to DIN 6885

CLAMP COUPLINGS DIN 115 / FORM A

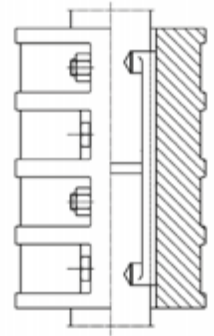
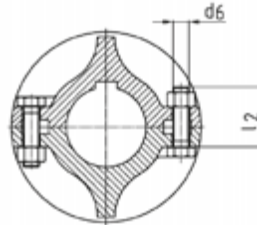

Size	Tolerance ²⁾	Torque $T_{max.}$ Nm		Max. rotational speed $n_{max.}$ rpm		Moments of inertia kgm ²		Weight kg		d_3 mm	l mm
		EN-GJL	GS	EN-GJL	GS	EN-GJL	GS	EN-GJL	GS		
d_1											
20	V 7	25	63	1700	1700	0.00093	0.0010	1.9	2.1	85	100
25	V 7	40	100	1500	1500	0.0034	0.0037	4.5	4.9	100	130
30	V 7	60	160	1500	1500	0.0034	0.0036	4.2	4.5	100	130
35	V 7	80	200	1420	1420	0.0066	0.0071	6.5	7.0	110	160
40	V 7	100	250	1420	1420	0.0065	0.0070	6.2	6.7	110	160
45	V 7	125	315	1350	1350	0.011	0.012	8.5	9.2	120	190
50	V 7	150	400	1300	1300	0.014	0.016	9.0	9.7	130	190
55	U 7	500	1600	1200	1200	0.026	0.028	13	14	150	220
60	U 7	850	1800	1200	1200	0.025	0.027	12.5	13.5	150	220
65	U 7	1250	2000	1120	1120	0.051	0.055	18.5	20	170	250
70	U 7	1700	2240	1120	1120	0.050	0.054	17	18	170	250
75 ¹⁾	U 7	2000	3150	1060	1060	0.107	0.116	28	30	190	280
80	U 7	2500	3550	1060	1060	0.106	0.114	27	29	190	280
90	U 7	3800	5000	1000	1000	0.203	0.219	41	44	215	310
100	U 7	5400	8000	920	920	0.399	0.431	63	68	250	350
110	U 7	7500	10000	920	920	0.467	0.505	70	76	250	390
120	U 7	11000	16000	870	870	0.771	0.832	96	104	275	430
125	U 7	11000	16000	870	870	0.759	0.820	93	100	275	430
140	U 7	15000	22400	800	800	1.63	1.76	160	173	325	490
160	U 7	23000	31500	750	750	2.84	3.07	255	275	365	560
180	U 7	32000	40000	690	690	5.42	5.86	320	346	420	630
200	U 7	40000	56000	630	630	12.02	12.98	550	594	500	700
220 ¹⁾	U 7	50000	80000	580	580	30.78	33.24	840	907	540	770

1) Not included in DIN 115

2) Hole tolerance field for shaft tolerance ISO h9

CLAMP COUPLINGS DIN 115 / FORM A

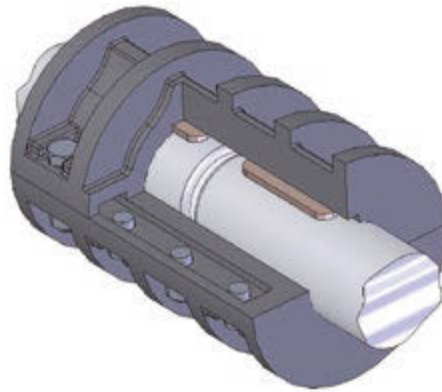

Size	Hexagon-head fitting bolts to DIN EN ISO 4014		Feather key length	Suspension key axial load max. kN
	d_o	l_z number		
20	M10 x 30	4	–	–
25	M12 x 40	4	–	5
30	M12 x 40	4	–	5
35	M12 x 50	6	–	8
40	M12 x 50	6	–	12
45	M12 x 50	6	–	16
50	M12 x 50	6	–	16
55	M16 x 55	6	100	20
60	M16 x 55	6	100	24
65	M16 x 55	6	100	24
70	M16 x 55	6	110	30
75 ¹⁾	M16 x 60	8	125	37
80	M16 x 75	8	125	37
90	M16 x 90	8	140	42
100	M20 x 90	8	160	55
110	M20 x 90	8	160	55
120	M24 x 90	10	200	70
125	M24 x 90	10	200	70
140	M27 x 110	10	200	90
160	M27 x 110	12	250	110
180	M27 x 130	12	280	–
200	M30 x 140	12	320	–
220 ¹⁾	M36 x 150	12	360	–

1) Not included in DIN 115

CLAMP COUPLINGS DIN 115 / FORM C

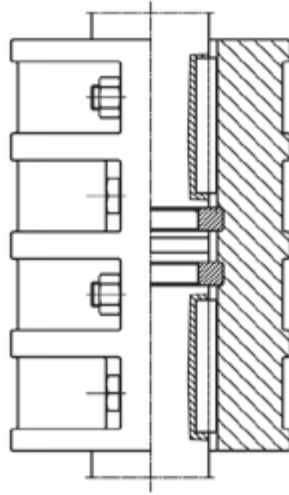

Size	Tolerance ²⁾	Torque $T_{max.}$ Nm		Max. rotational speed $n_{max.}$ rpm		Moments of inertia kgm ²		Weight kg		d_3 mm	l mm
		EN-GJL	GS	EN-GJL	GS	EN-GJL	GS	EN-GJL	GS		
d_1											
25	V 7	40	100	1420	1420	0.0066	0.0071	7.0	7.5	110	160
30	V 7	60	160	1420	1420	0.0065	0.0070	6.8	7.3	110	160
35	V 7	80	200	1350	1350	0.011	0.012	9.3	10.0	120	190
40	V 7	100	250	1300	1300	0.014	0.016	9.9	10.7	130	190
45	V 7	125	315	1200	1200	0.026	0.028	14.2	15.3	150	220
50	V 7	150	400	1200	1200	0.025	0.027	13.8	14.8	150	220
55	U 7	500	1600	1120	1120	0.051	0.055	20.1	21.6	170	250
60	U 7	850	1800	1120	1120	0.050	0.054	18.7	20.1	170	250
65	U 7	1250	2000	1060	1060	0.107	0.116	30.0	32.3	190	280
70	U 7	1700	2240	1060	1060	0.106	0.114	29.2	31.4	190	280
75 ¹⁾	U 7	2000	3150	1000	1000	0.203	0.219	45.1	48.5	215	310
80	U 7	2500	3550	1000	1000	0.203	0.219	43.7	47.0	215	310
90	U 7	3800	5000	920	920	0.399	0.431	66.4	71.4	250	350
100	U 7	5400	8000	920	920	0.467	0.505	74.3	79.9	250	390
110	U 7	7500	10000	870	870	0.771	0.832	101.0	108.7	275	430
120	U 7	11000	16000	800	800	1.63	1.76	173.5	186.7	325	490
125	U 7	11000	16000	800	800	1.63	1.76	170.1	183.0	325	490
140	U 7	15000	22400	750	750	2.84	3.07	272.5	293.2	365	560
160	U 7	23000	31500	690	690	5.42	5.86	342.4	368.4	420	630
180	U 7	32000	40000	630	630	12.02	12.98	577.0	620.8	500	700
200 ¹⁾	U 7	40000	56000	580	580	30.78	33.24	871.8	937.9	540	770

1) Not included in DIN 115

2) Hole tolerance field for shaft tolerance ISO h9

CLAMP COUPLINGS DIN 115 / FORM C

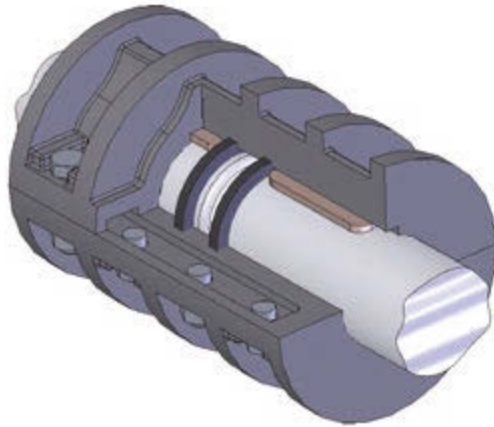

Size d_1	Hexagon-head fitting bolts to DIN EN ISO 4014		Feather key length	Maximum lateral load on insert ring max. kN
	d_6 l_2	number		
25	M12 x 50	6	56	12
30	M12 x 50	6	56	17
35	M12 x 50	6	70	23
40	M12 x 50	6	70	30
45	M16 x 55	6	80	36
50	M16 x 55	6	80	45
55	M16 x 55	6	90	53
60	M16 x 55	6	90	62
65	M16 x 60	8	100	72
70	M16 x 60	8	100	82
75 ¹⁾	M20 x 75	8	110	92
80	M20 x 75	8	110	105
90	M20 x 90	8	125	135
100	M24 x 90	8	140	165
110	M24 x 90	10	160	200
120	M27 x 110	10	180	250
125	M27 x 110	10	180	250
140	M27 x 110	12	200	310
160	M27 x 130	12	220	400
180	M30 x 140	12	250	500
200 ¹⁾	M36 x 150	12	280	600

1) Not included in DIN 115

FLANGE COUPLINGS DIN 116

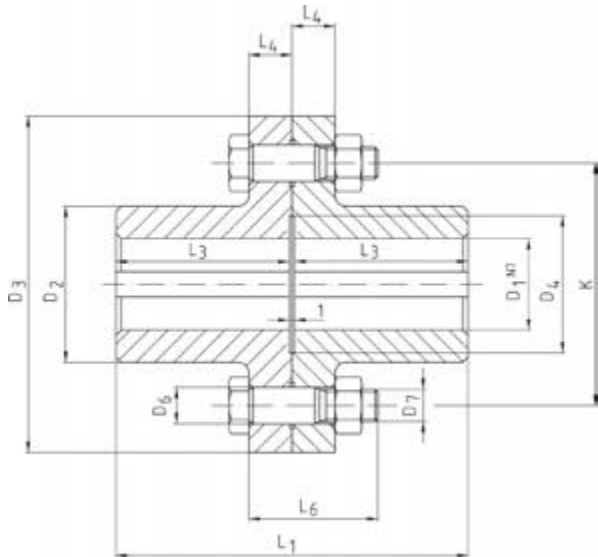

Form A

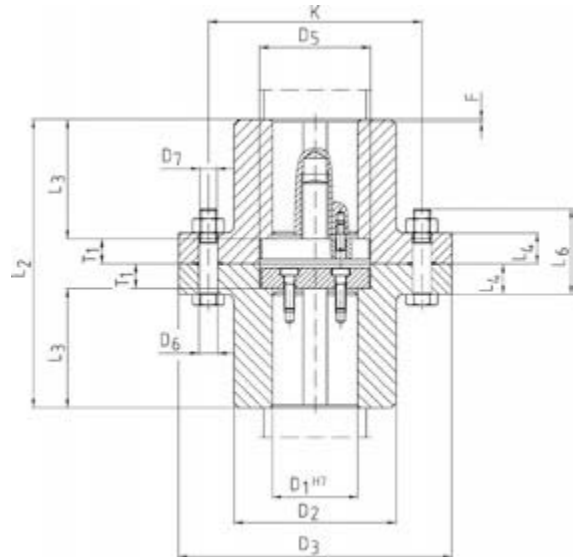

Form C

Size	D ₂	D ₃	D ₄	D ₅	D ₆ (H7)	K	L ₁	L ₂	L ₃ ²⁾	L ₄	F ³⁾	T ₁	Hexagon-head fitting bolts to DIN 609		
													D ₇	L ₆	number
25	58	125	40	45	11	90	101	117	50	16	1	8.5	M10	45	3
30	58	125	40	45	11	90	101	117	50	16	1	8.5	M10	45	3
35	72	140	50	55	11	100	121	141	60	16	1	10.5	M10	45	3
40	72	140	50	55	11	100	121	141	60	16	1	10.5	M10	45	3
45	95	160	60	65	11	125	141	169	70	18	1	14.5	M10	50	3
50	95	160	60	65	11	125	141	169	70	18	1.6	14.5	M10	50	3
55	110	180	70	75	13	140	171	203	85	18	1.6	16.5	M12	50	4
60	110	180	70	75	13	140	171	203	85	18	1.6	16.5	M12	50	4
70	130	200	80	85	13	160	201	233	100	23	1.6	16.5	M12	60	6
80	145	224	90	95	13	180	221	261	110	23	1.6	20.5	M12	60	8
90	164	250	100	105	17	200	241	281	120	30	2.5	20.5	M16	80	8
100	180	280	110	120	17	224	261	301	130	30	2.5	20.5	M16	80	8
110	200	300	120	130	17	250	281	329	140	33	2.5	24.5	M16	85	8
120	225	335	135	145	17	280	311	359	155	33	2.5	24.5	M16	85	10
125	225	335	135	145	17	280	311	359	155	33	4	24.5	M16	85	10
140	250	375	150	160	21	310	341	397	170	40	4	28.5	M20	100	10

- 1) Grooves according to DIN 6685/1; tolerance zone JS9
- 2) Tolerance of hub length: L₃ ≤ 120: +0.3 and L₃ > 120: +0.5 respectively
- 3) Bevel F x 45°

TECHNICAL DATA

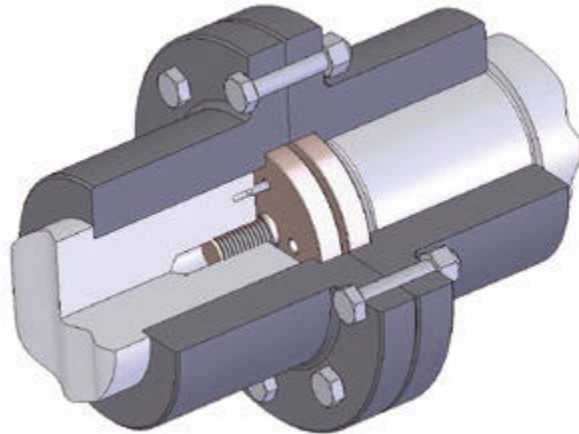

Form C

Size D ₁ ⁴⁾	Torque		Max. rotational speed		Moments of inertia ³⁾ Form A		Weight ³⁾ Form A		Moments of inertia ³⁾ Form C		Weight ³⁾ Form C	
	T _{max.} Nm		n _{max.} rpm		kgm ²		kg		kgm ²		kg	
	EN-GJL ¹⁾	GS ²⁾⁵⁾	EN-GJL	GS ⁵⁾	EN-GJL	GS ⁵⁾	EN-GJL	GS ⁵⁾	EN-GJL	GS ⁵⁾	EN-GJL	GS ⁵⁾
25	46.2	69	4600	6850	0.0062	0.0067	3.9	4.2	0.0063	0.0068	4.0	4.3
30	87.5	131	4600	6850	0.0062	0.0067	3.7	4.0	0.0062	0.0067	3.8	4.1
35	150	225	4100	6150	0.0105	0.0113	5.4	5.8	0.0107	0.0116	5.7	6.1
40	236	354	4100	6150	0.0104	0.0112	5.2	5.5	0.0106	0.0115	5.4	5.8
45	355	533	3600	5350	0.023	0.025	9.1	10.0	0.024	0.026	9.8	10.6
50	515	773	3600	5350	0.023	0.024	8.7	9.4	0.024	0.026	9.5	10.2
55	730	1095	3200	4750	0.041	0.044	13.1	14.2	0.043	0.047	14.3	15.5
60	975	1463	3200	4750	0.040	0.043	12.6	13.6	0.043	0.046	13.7	14.8
70	1700	2550	2850	4300	0.082	0.088	20.0	21.6	0.087	0.094	21.8	23.5
80	2650	3975	2550	3850	0.134	0.144	26.4	28.5	0.144	0.155	29.1	31.4
90	4120	6180	2300	3450	0.257	0.276	38.7	41.8	0.274	0.295	42.3	45.7
100	5800	8700	2050	3050	0.404	0.435	49.8	53.7	0.428	0.461	53.8	58.2
110	8250	12375	1900	2850	0.608	0.652	64.1	68.9	0.652	0.699	70.4	75.7
120	11 200	16 800	1700	2550	1.011	1.085	88.2	94.7	1.084	1.163	96.3	103.4
125	12 800	19 200	1700	2550	1.003	1.076	86.0	92.4	1.075	1.154	102.1	109.7
140	19 000	28 500	1550	2300	1.81	1.93	121	130	1.93	2.07	133	142

1) Max. torque based on DIN 116 Hole tolerance zone:

Form A: ISO H7 – for shaft tolerance ISO h9

Form C: ISO N7 – for shaft tolerance ISO k6 and m6 respectively

Other hole tolerances can be agreed when ordering.

2) Max. torques (for hole D1) with allowable load on the feather key and with average overdimension of the following tolerance zones:

For D1 ≤ 50: ISO N7 – for shaft tolerance ISO k6

For D1 > 50: ISO N7 – for shaft tolerance ISO m6

3) Figures for moments of inertia and weights for hole D1 (in the case of form C without axial thrust washer)

4) Couplings for D1 = 260 to 500 mm are not included in DIN 116.

5) Couplings up to size 100 of steel

FLANGE COUPLINGS DIN 116

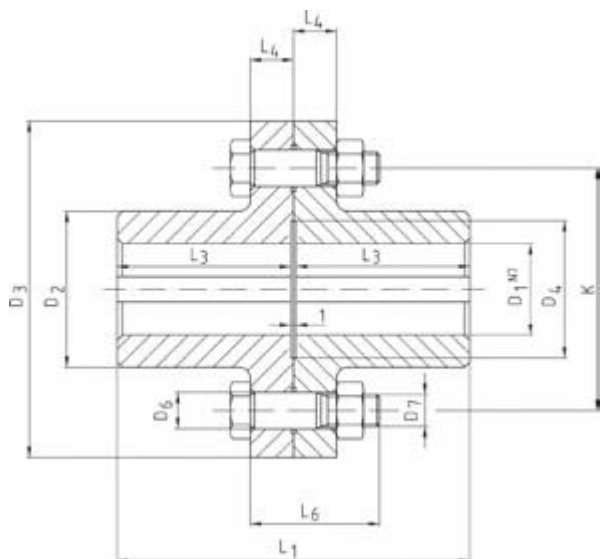

Form A

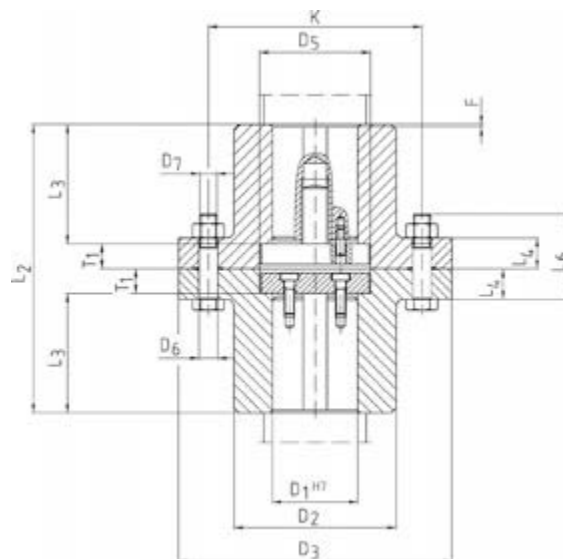

Form C

Size	D ₂	D ₃	D ₄	D ₅	D ₆ H7	K	L ₁	L ₂	L ₃ ²⁾	L ₄	F ³⁾	T ₁	Hexagon-head fitting bolts to DIN 609		
													D ₇	L ₆	number
160	290	425	240	180	25	350	401	457	200	40	4	28.5	M24	110	10
180	325	450	265	212	25	380	451	507	225	45	4	28.5	M24	120	12
200	360	500	290	232	25	420	501	557	250	45	6	28.5	M24	120	16
220	400	560	310	252	32	470	541	597	270	52	6	28.5	M30	140	14
250	450	630	390	282	32	540	601	657	300	52	6	28.8	M30	140	16
260	500	710	420	302	32	600	681	741	340	55	6	30.5	M30	150	16
280	500	710	420	322	32	600	681	741	340	55	6	30.5	M30	150	16
300	560	750	460	352	38	640	761	831	380	62	10	35.5	M36	170	16
320	560	750	460	372	38	640	761	831	380	62	10	35.5	M36	170	16
340	650	900	520	392	44	760	881	961	440	70	10	40.5	M42	190	14
360	650	900	520	412	44	760	881	961	440	70	10	40.5	M42	190	14
380	720	1000	600	442	44	850	1001	1091	500	70	10	45.5	M42	190	16
400	720	1000	600	462	44	850	1001	1091	500	70	10	45.5	M42	190	16
420	800	1060	650	482	50	920	1161	1251	580	80	10	45.5	M48	220	16
450	800	1060	650	512	50	920	1161	1251	580	80	10	45.5	M48	220	16
460	900	1180	800	532	50	1030	1321	1421	660	90	10	50.5	M48	240	20
500	900	1180	800	572	50	1030	1321	1421	660	90	16	50.5	M48	240	20

- 1) Grooves according to DIN 6685/1; tolerance zone JS9
- 2) Tolerance of hub length: L₃ ≤ 120: +0.3 and L₃ > 120: +0.5 respectively
- 3) Bevel F x 45°

TECHNICAL DATA

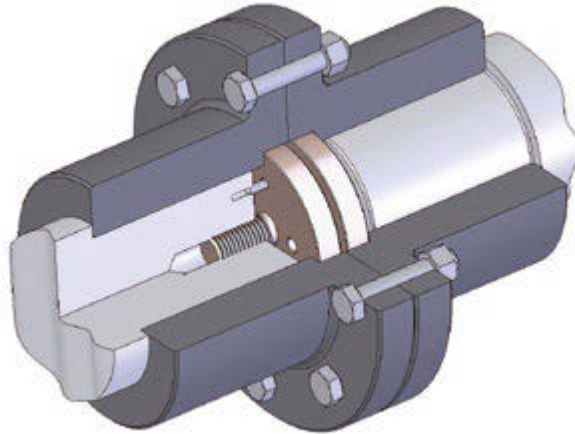

Form C

Size	Torque		Max. rotational speed		Moments of inertia ²⁾		Weight ³⁾		Moments of inertia ³⁾		Weight ³⁾	
	T _{max.} Nm		n _{max.} rpm		kgm ²		kg		kgm ²		kg	
D ₁ ⁴⁾	EN-GJL ¹⁾	GS ²⁾⁵⁾	EN-GJL	GS ⁵⁾	EN-GJL	GS ⁵⁾	EN-GJL	GS ⁵⁾	EN-GJL	GS ⁵⁾	EN-GJL	GS ⁵⁾
160	30700	46050	1350	2000	3.39	3.63	181	194	3.63	3.89	197	212
180	45000	67500	1250	1900	5.30	5.68	242	259	5.67	6.07	261	280
200	61500	92250	1150	1700	8.58	9.19	322	346	9.14	9.79	347	372
220	82500	123750	1000	1550	14.87	15.92	444	476	16.00	17.14	485	521
250	118000	177000	900	1350	25.29	27.09	605	649	26.69	28.59	644	692
260	136000	204000	800	1200	44.09	47.28	877	942	46.42	49.79	932	1001
280	170000	255000	800	1200	43.32	46.46	835	897	45.55	48.85	886	951
300	206000	309000	750	1150	70.10	75.14	1163	1248	74.26	79.61	1239	1330
320	250000	375000	750	1150	68.81	73.74	1109	1191	72.77	78.01	1179	1266
340	300000	450000	650	950	155.03	166.24	1874	2013	163.89	175.77	1997	2146
360	355000	532500	650	950	152.88	163.93	1804	1937	161.43	173.13	1920	2062
380	425000	637500	550	850	255.02	273.58	2545	2733	269.85	289.55	2711	2913
400	487000	730500	550	850	251.63	269.94	2457	2639	265.99	285.39	2613	2807
420	560000	840000	550	800	420.01	450.49	3552	3814	442.88	475.09	3762	4040
450	710000	1065000	550	800	411.84	441.69	3378	3628	433.75	465.27	3574	3838
460	750000	1125000	500	750	755.07	810.06	5156	5538	796.31	854.42	5458	5864
500	950000	1425000	500	750	738.28	792.00	4866	5226	777.58	834.27	5142	5524

1) Max. torque based on DIN 116 Hole tolerance zone:

Form A: ISO H7 – for shaft tolerance ISO h9

Form C: ISO N7 – for shaft tolerance ISO k6 and m6 respectively

Other hole tolerances can be agreed when ordering.

2) Max. torques (for hole D1) with allowable load on the feather key and with average overdimension of the following tolerance zones:

For D1 ≤ 50: ISO N7 – for shaft tolerance ISO k6

For D1 > 50: ISO N7 – for shaft tolerance ISO m6

3) Figures for moments of inertia and weights for hole D1 (in the case of form C without axial thrust washer)

4) Couplings for D1 = 260 to 500 mm are not included in DIN 116.

5) Couplings up to size 100 of steel