

ROLLON[®]
BY TIMKEN

Telescopic Line



General catalogue
English

Interactive catalogs
on: www.rollon.com



TO SUPPORT YOU, WE DESIGN AND PRODUCE

An industrialized process with various levels
of customization



For over 45 years, Rollon has adopted an approach entailing responsibility and ethics in the design and production of our linear motion solutions for different industrial sectors. The reliability of an international technology group has now been combined with the availability of a local support and service network



VALUES



PERFORMANCE



Rollon's goal is to help our clients become more competitive in their markets through technological solutions, design simplification, productivity, reliability, duration, and low maintenance.

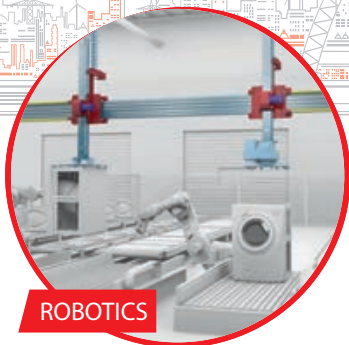

ROBOTICS

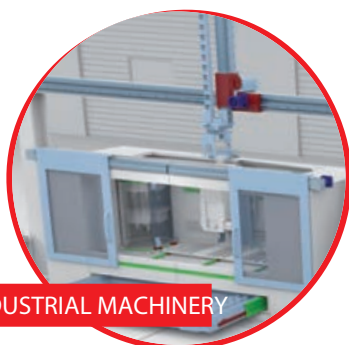

INDUSTRIAL MACHINERY

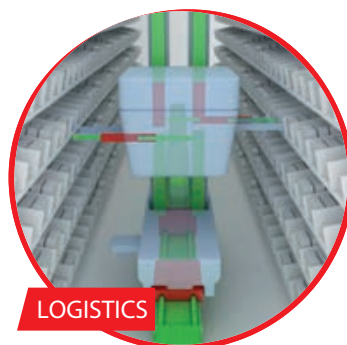

LOGISTICS



RAILWAY

COLLABORATION



High-level technical consulting and cross-competence allow us to identify the needs of our clients and transform them into guidelines for continuous exchange, while our strong specialization in the different industrial sectors becomes an factor in developing projects and innovative applications.

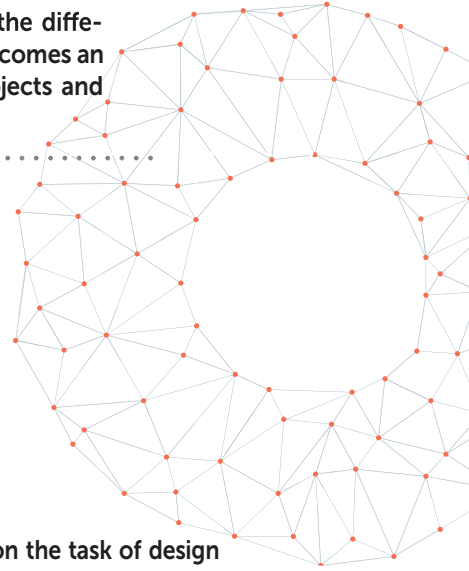

Rollon takes on the task of design and development of linear motion solutions, taking care of everything for our customers, so that they can concentrate on their core business. We offer everything from individual components to specifically designed, mechanically integrated systems: the quality of our applications is an expression of our technology and competence.

SOLUTIONS APPLICATIONS



INTERIORS AND ARCHITECTURE



MEDICAL



SPECIAL VEHICLES



AERONAUTICS

DIVERSIFIED LINEAR SOLUTIONS FOR EVERY APPLICATION REQUIREMENT

Linear and telescopic rails

Linear Line



Linear and curved rails with ball and roller bearings, with hardened raceways, high load capacity, self-alignment, and capable of working in dirty environments.

Telescopic Line



Telescopic rails with ball and roller bearings, with hardened raceways, high load capacities, low bending, resistant to shocks and vibrations. For partial, total or extended extraction up to 200% of the length of the guide.

Linear actuators and automation systems

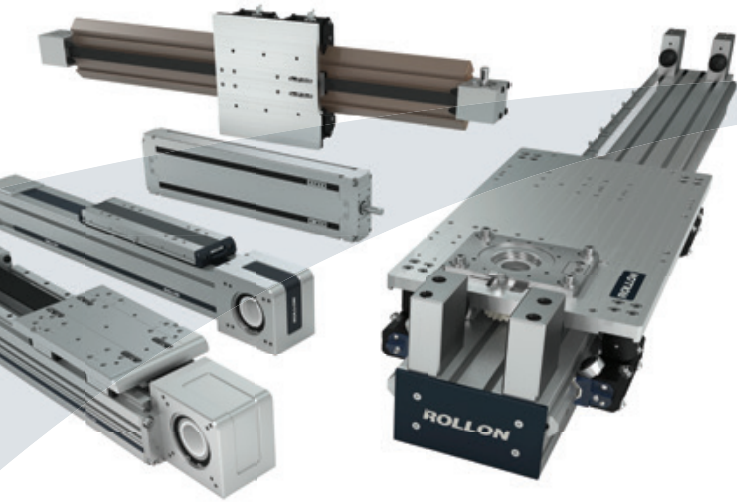

Actuator Line

Linear actuators with different rail configurations and transmissions, available with belt, screw, or rack and pinion drives for different needs in terms of precision and speed. Rails with bearings or ball recycle systems for different load capacities and critical environments.

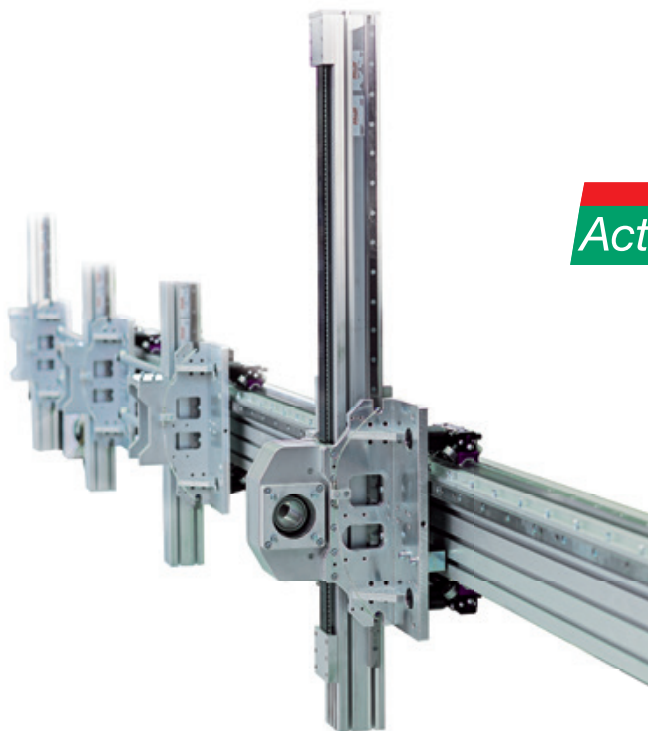

Actuator System Line

Integrated actuators for industrial automation, used in applications in several industrial sectors: automated industrial machinery, precision assembly lines, packaging lines and high speed production lines. The Actuator Line evolves to satisfy the requests of our most discerning clients.

> **Telescopic Rail**



Technical features overview

1 Product explanation

Telescopic Rail: Seven models with full and partial extension

TR-2

2 Product cross sections

TR-5

3 Technical data

Performance characteristics and notes

TR-7

4 Dimensions and load capacity

ASN

TR-8

DSS

TR-12

DSS...S

TR-14

DSB

TR-16

DSD

TR-17

DSE

TR-19

DSC

TR-21

DE

TR-23

DE...S

TR-26

DE...D

TR-28

DE...Z

TR-30

DBN

TR-32

DMS

TR-34

5 Technical instructions

Telescopic rail selection, Static load check

TR-36

Deflection

TR-37

Static load

TR-38

Service life

TR-39

Speed, Extension and extraction force,

Double-sided stroke, Temperature

TR-42

Anticorrosive protection, Lubrication, Clearance and preload

TR-43

Fixing screws

TR-44

Installation instructions

TR-45

Ordering key

Ordering key with explanations

TR-47

> Hegra Rail



1 Product explanation Partial and full extension guides of different types	HR-2
2 Product cross sections	HR-4
3 Technical data Performance characteristics and notes	HR-6
4 Load capacities and dimensions HTT HVC H1C H1T H2H LTH HGT LTF HGS	HR-7 HR-11 HR-16 HR-18 HR-22 HR-24 HR-31 HR-35 HR-37
5 Accessories Locking, driving disc, damping	HR-39
6 Technical information Selecting a suitable telescoping rail, Mounting tolerances, Life cycle, Load capacity, Deflection, Operating temperature, Corrosion protection, Ball cage displacement, Moving force, Lubrication Maintenance intervals, Assembly information	HR-40 HR-41 HR-42
Ordering key Ordering key with explanations	HR-43

> Telerace



1 Product explanation

Telescopic rails with rollers designed for industrial automations.

TL-2

2 Overview product cross sections

TLR...P-TLQ...P series, TLN...P - TQN...P series

TL-5

TLAX-TQAX series

TL-6

3 Technical data

Performance characteristics, Remarks

TL-7

4 Dimensions and load capacity

TLR...P

TL-8

TLQ...P

TL-10

TLN...P

TL-12

TQN...P

TL-14

TLAX

TL-16

TQAX

TL-18

5 Technical instructions

Telescopic rail selection, Deflection

TL-20

Sizing of telescopic applications

TL-21

Verification of load capacity

TL-22

Lifetime calculation

TL-23

Opening and closing force

TL-24

Lubrication. Anticorrosion treatments

TL-25

Speed

TL-26

Self-aligning system with TLR...AP

TL-27

Stroke customization for TLQ...P, TQN...P, TQAX

TL-28

Installation instructions

TL-29

Fixing screws

TL-30

Ordering key

TL-31

> Light Rail



1 Product explanation

Light telescopic rails, with full or partial extension

LR-2

2 Overview product cross sections

Partial extension guides, Full extension guides, Overextending guides

LR-4

3 Technical data

Performance characteristics and notes

LR-5

4 Dimensions and load capacity

LRS37

LR-6

LFS46

LR-7

LRS56

LR-8

LRS71

LR-9

LRS76

LR-10

LRS710E

LR-11

5 Accessories

Locking, Damping, Snap

LR-12

6 Technical instructions

Load capacities, Overall dimension

LR-13

Alignment, Stroke tolerance, Distances

LR-14

Fixations, Load capacity

LR-15

Abnormal loads / vibrations, Anticorrosion treatments,

Lubrication, Speed, Temperature

LR-16

Installation instructions

LR-17

Ordering key

Ordering key with explanations

LR-18

Technical features overview



Reference			Product name	Extraction	Size	Profile		Self alignment	Slider		Steel
Product Family	Product	Section				Type	Hardened raceways		Balls	Rollers	
Telescopic Rail		ASN		ASN22	50%	22	Cold Draw	■	+	■	■
				ASN28		28					
				ASN35		35					
				ASN43		43					
				ASN63		63					
		DE		DE...22	100%	22	Cold Draw	■	++	■	■
				DE...28		28					
				DE...35		35					
				DE...43		43					
				DE...63		63					
DE...28S				28							
DE...35S				35							
DE...43S				43							
DE...28D				28							
DE...35D				35							
DE...43D	43										
	DS		DSS28	100%	28	Cold Draw	■	++	■	■	
			DSS35		35						
			DSS43		43						
			DSS63		63						
			DSS43S		43						
			DSB28		28						
			DSB35		35						
			DSB43		43						
			DSD28		28						
			DSD35		35						
DSD43	43										
	DSC		DSC43	100%	43	Cold Draw	■	++	■	■	
			DBN22	100%	22	Cold Draw	■	++	■	■	
DBN28	28										
DBN35	35										
	DBN		DBN43	43							
			DMS63	100%	63	Cold Draw	■	++	■	■	
	DMS		DSE28	150	28	Cold Draw	■	++	■	■	
			DSE35		35						
	DSE		DSE43		43						
			DSE63		63						

Reported data must be verified according to the application.

* The maximum value is defined by the application. For more information, please contact our technical department.

■ standard

X steel
A stainless steel
aluminum

B stroke in both directions
BM stroke in both directions with driving disc



Material		Stroke direction		Snap	Locking closed position	Damping closed position	Max. load capacity per pair [N]		Max. rail length [mm]	Max. stroke [mm]	Max. extension speed* [m/s]	Rigidity (deflection)	Operating temperature [°C]
X	A	B	BM				C _{0rad}	C _{0ax}					
			■				5934	4154	770	394	0.8	+++	-20°C/+170°C
			■				15736	11014	1170	601	0.8		
			■				26520	18564	1490	759	0.8		
			■				48596	34018	1970	1013	0.8		
			■				88494	61946	1970	1013	0.8	-20°C/+170°C	
			■				1348	546	770	788	0.8		
			■				2338	1074	1170	1202	0.8		
			■				3816	1586	1490	1518	0.8		
			■				6182	2868	1970	2026	0.8		
			■				14396	6124	1970	2026	0.8		
					■		2100	758	1170	1186	0.8		
					■		3540	1574	1490	1510	0.8		
					■		5964	2522	1970	2066	0.8		
							2014	856	1170	1216	0.8		
							3460	1534	1490	1503	0.8	-20°C/+170°C	
			■				5784	2484	1970	2011	0.8		
							15512	6514	1970	1962	0.8	+++	-20°C/+170°C
							7524	3830	1970	1923	0.8		
						■	4480	-	1490	1518	0.8		
						■	7016	-	1730	1758	0.8		
						■	9816	-	1970	2026	0.8		
						■	25664	-	1970	2026	0.8		
						■	10208	-	1970	2026	0.8		
					■		4480	-	1490	1518	0.8		
					■		7016	-	1730	1758	0.8		
					■		9816	-	1970	2026	0.8		
							5162	-	1490	1446	0.8	-20°C/+80°C	
						■	9736	-	1730	1630	0.8		
						■	11660	-	1970	1916	0.8		
						■	38018	-	1970	1758	0.8		
											+++	-20°C/+80°C	
						■	11058	4150	1970	2028			0.8
											+	-20°C/+170°C	
			■				562	472	770	788			0.8
			■				1244	1074	1170	1202			0.8
			■				1334	1120	1490	1518			0.8
			■				2662	2558	1970	2026	0.8		
											++++	-20°C/+80°C	
						■	39624	-	2210	2266			0.8
											++++	-20°C/+80°C	
							1702	-	1170	1803			0.8
							3182	-	1490	2277			0.8
							5012	-	1970	3039			0.8
							11344	-	1970	3039	0.8		

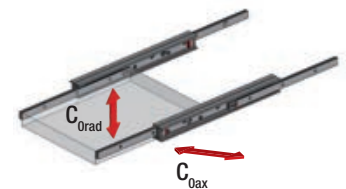

T
R

H
R

T
L

L
R

Technical features overview



Reference			Product name	Extraction	Size	Profile		Self alignment	Slider		Steel
Product Family	Product	Section				Type	Hardened raceways		Balls	Rollers	
Hegra Rail		HTT		HTT030	 60 % to 66 %	30	Machined		+	●	●
				HTT040		40					
				HTT050		50					
		HVC		HVC045	 100 %	45	Bended sheetmetal & cold drawn		++	●	●
				HVC050		50					
				HVC058		58					
				HVC075		75					
		H1C*1		H1C075	 150%	75	Machined, cold drawn & bended sheetmetal		++	●	●
		H1T*1		H1T060	 150 % to 200 %	60	Machined & cold drawn		++	●	●
				H1T080		80					
				H1T100		100					
				H1T150		150					
		H2H		H2H080	 150 % to 200 %	80			++	●	●
		LTH		LTH30	 100 %	30	Cold drawn		++	●	●
				LTH45		45					
				LTH30S		30					
				LTH45S		45					
		HGT		HGT060	 100 %	60	Machined & cold drawn		++	●	●
				HGT080		80					
HGT100				100							
HGT120				120							
HGT150				150							
HGT200				200							
HGT240				250							
	LTF		LTF44	 100 %	44	Cold drawn		++	●	●	
	HGS		HGS060	 100 %	60	Machined		++	●	●	

Reported data must be verified according to the application.

In many cases, special designs or alternative surface coatings are possible. For more information, please contact our technical department.

*1 The over extension corresponds to 150 % stroke (1=150 % extraction). For a 200 % stroke (2=200 % extraction) please contact our technical department.

*2 Different temperature ranges from -30 °C to +250 °C, This must be verified according to the application.

*3 The load capacity for aluminum is 40 % and for stainless steel 60 % of the stated values, if available in this material variant.

*4 Different stainless steels, such as the «electropolishing» option, are available. For more information, please contact our technical department.

*5 The availability of locking systems depends on the system length and varies per product group. For more information, please contact our technical department.

*6 The operating temperature is maximum +50°C if damping is used. For more information, please contact our technical department.

*7 The maximum value is defined by the application. For more information, please contact our technical department.

- feasible
- ▲ only to length 1000
- standard

Material		Stroke direction			Snap			Locking*5			Damp- ing	Max. load capacity per pair [N]		Max. rail length [mm]	Max. stroke [mm]	Max. extension speed*7 [m/s]	Rigidity (deflection)	Operating temperature*2*6 [°C]
X*4	A	B	BM	EG	EO	EB	VG	VO	VB	DG	C _{0rad} *3	C _{0ax}						
•	•	•		•	•	•				■	1200	on request	1000	660	0.8	+++	-20°C/+170°C	
				•	•	•				■	2550		1000	660				
				•	•	•				■	2900		1200	720				
							•	•	•		1200	on request	1200	1200	0.8	+	-20°C/+170°C	
•		•	•	•	•	•	•	•	•	•	1500		1500	1500				
				•	•	•	•	•	•	•	2100		1500	1500				
							•	•	•		3300		2000	2000				
			•		•	•				•	1350	-	1500	2250	0.5	+	-20°C/+170°C	
•	•	•		•	•	•				•	2600	-	1500	2250	0.5	++	-20°C/+170°C	
				•	•	•				•	3200	-	1500	2250				
										•	5500	-	2000	3000				
										•	7500	-	2000	3000				
•	•			•	•	•				•	on request	-	2000	3000	0.5	++	-20°C/+170°C	
											1470	on request	1200	1215	0.5	++	-20°C/+170°C	
											3346		1500	1522				
										•	1498		1200	1217				
										•	3084		1500	1522				
•	•	•	•	•	•	•	•	•	•	•	5500	on request	1500	1500	0.5	+++	-20°C/+170°C	
				▲	▲	▲					9350		2000	2000				
											11000		2000	2000				
											11800		2000	2000				
											13900		2000	2000				
											17500		2300	2300				
											20000		2000	2000				
			•								1296	-	1010	1010	0.3	+	-20°C/+170°C	
•	•	•		•	•	•					1400	-	1000	1000	0.5	+++	-20°C/+170°C	

X steel
 stainless steel
 A aluminum

B stroke in both directions
 BM stroke in both directions with driving disc

EG snap on closed position
 EO snap on opened position
 EB snap on both positions

VG locking closed position
 VO locking opened position
 VB locking both positions

DG damping closed position

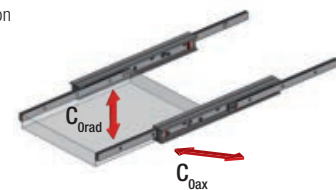

T
R

H
R

T
L

L
R

Technical features overview



Reference			Product name	Extraction	Size	Profile		Self alignment	Slider			
Product Family	Product	Section				Type	Rollon NOX hardening*1		Balls	Rollers	Steel	
Telerace		TLR...P 		TLR18P		18	Cold Draw	■	+++		■	■
				TLR28P		28						
				TLR43P		43						
		TLQ...P 		TLQ18P		18	Cold Draw	■	+		■	■
				TLQ28P		28						
				TLQ43P		43						
		TLN...P		TLN30P		30	Rolled Sheetmetal	■	+		■	■
				TLN40P		40						
		TQN...P		TQN30P		30	Rolled Sheetmetal	■	+		■	■
				TQN40P		40						
		TLAX		TLAX26		26	Rolled Sheetmetal		+		■	
				TLAX40		40						
	TQAX		TQAX26		26	Rolled Sheetmetal		+		■		
			TQAX40		40							

Reported data must be verified according to the application.

*1 High dept nitride hardening treatment and oxidation.

*2 The maximum value is defined by the application. For more information, please contact our technical department.

■ standard

X steel

■ stainless steel

A aluminum

B

BM

stroke in both directions

stroke in both directions

with driving disc

Reference			Product name	Extraction	Size	Profile		Self alignment	Slider			
Product Family	Product	Section				Type	Hardened raceways		Balls	Rollers	Steel	
Light Rail		LRS		LRS37		70%	37	Roll forming		++	■	■
		LFS		LFS46		100%	46	Roll forming		++	■	■
		LRS		LRS56		100%	56	Roll forming		++	■	■
				LRS71			71					
				LRS76			76					
	LRS710E		LRS710E		150%	71	Roll forming		++	■	■	

Reported data must be verified according to the application.

*1 Lock-in feature not assembled. Device enclosed to each delivery.

*2 The maximum value is defined by the application. For more information, please contact our technical department.

■ standard

● option

X stainless steel

A aluminum

B

BM

stroke in both directions

stroke in both directions

with driving disc

Material		Stroke direction		Suitable for variable stroke cycles	Suitable for vertical stroke	Damping closed position	Max. load capacity per pair [N]		Max. rail length [mm]	Max. stroke [mm]	Max. extension speed*2 [m/s]	Rigidity (deflection)	Operating temperature [°C]
X	A	B	BM				C _{Orad}	C _{Oax}					
				■		■	1361	-	770	770	1.0	++++	-20 °C/+110 °C
							3455	-	1490	1500			
							8326	-	1970	1980			
				■	■	■	863	379	770	770	1.0	+++	-20 °C/+110 °C
							2146	820	1490	1490			
							5357	2359	1970	1970			
				■		■	2540	-	1490	1500	1.0	++++	-20 °C/+80 °C
							5094	-	1970	1980			
				■	■	■	1190	521	1490	1490	1.0	+++	-20 °C/+80 °C
							2251	1327	1970	1970			
■				■		■	1329	-	1200	1200	1.0	++++	-20 °C/+80 °C
							2133	-	1600	1600			
■				■	■	■	869	405	1200	1200	1.0	+++	-20 °C/+80 °C
							1880	855	1600	1600			

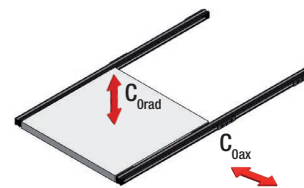

Material		Stroke direction		Snap closed position	Locking*1			Damping closed position	Max. load capacity per pair [N]		Max. rail length [mm]	Max. stroke [mm]	Max. extension speed*2 [m/s]	Rigidity (deflection)	Operating temperature [°C]
X	A	B	BM		VG	VO	VB		C _{Orad}	C _{Oax}					
				■				■	780	-	700	541	0.5	+	-20°C - +80 °C
								■	400	-	600	610	0.5	+	+10°C/+40 °C
				■				■	1290	-	1100	1100	0.5	+	-20°C - +80 °C
				■				■	2120	-	1100	1100			
					●	●	●	■	3250	-	1500	1504			
						●		■	1000	-	900	1350	0.5	+	-20°C/+80 °C

VG = locking closed position
VO = locking opened position
VB = locking both positions

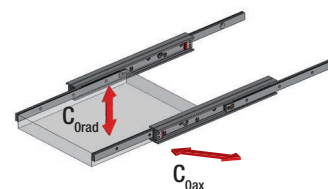

T
R

H
R

T
L

L
R

ROLLON[®]
BY TIMKEN

Telescopic Rail

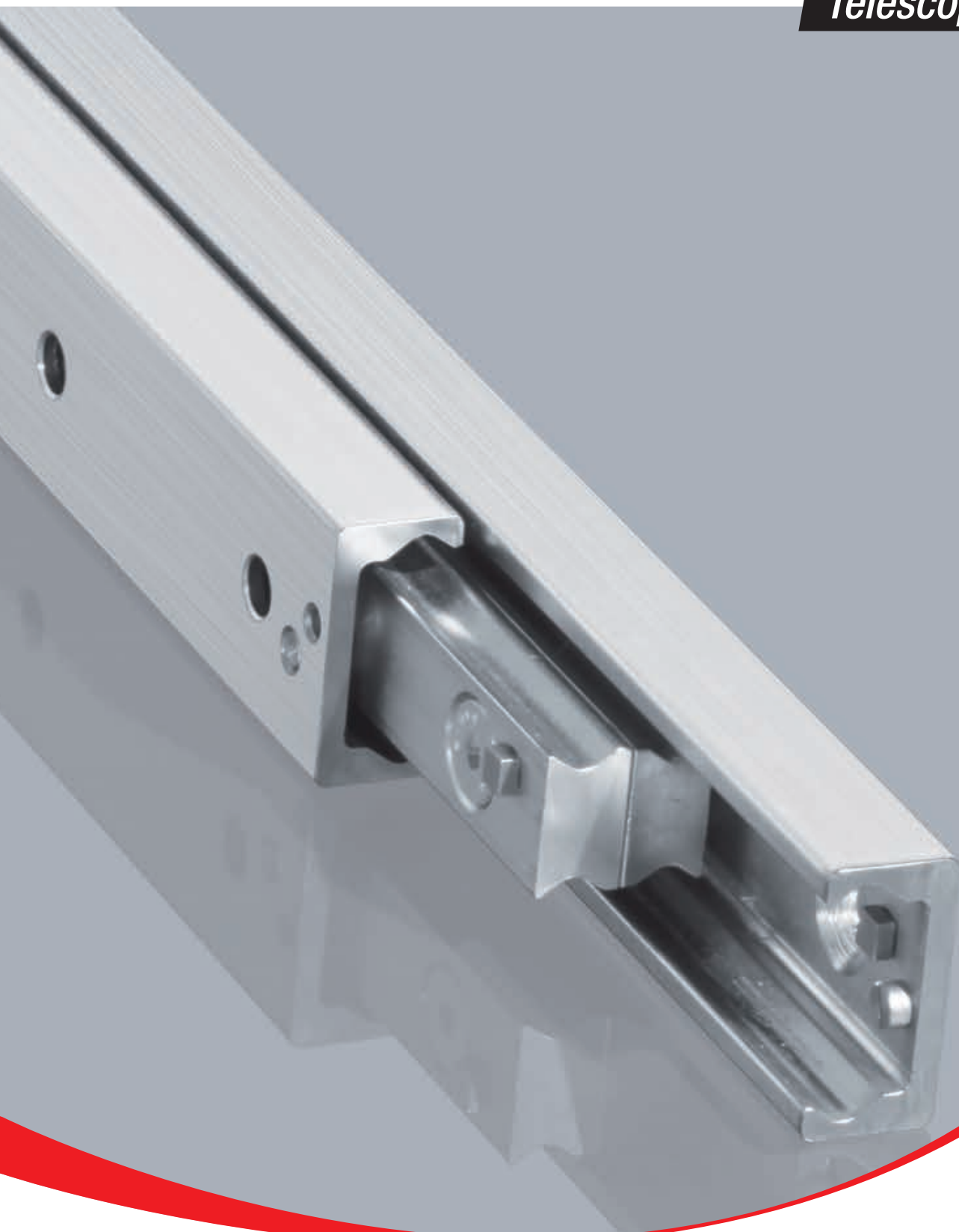

Product explanation



> Telescopic Rail: Seven models with full and partial extension



Fig. 1

The Telescopic Rail product line is made up of seven models with full and partial extension and various cross-sections and intermediate elements in S-shape, I-beam or square. High loads in combination with cost-efficiency and free movement have long been the outstanding properties of the Telescopic Rail product line.

The most important characteristics:

- High load capacity with low deflection
- Rigid intermediate elements
- Standardized hole locations
- Zero-play running even with maximum load
- Space saving design
- High reliability

Preferred areas of application of the Telescopic Rail product family:

- Railcars (e. g. maintenance and battery extensions, doors)
- Construction and machine technology (e.g., housings and doors)
- Logistics (e.g., extensions for containers or gripper movements)
- Automotive technology
- Packaging machines
- Beverage industry
- Special machines

ASN

Partially extending telescopic rail consisting of a guide rail and a slider. This compact and simple design allows for very high load capacities. When the guide rail is mounted to a structure a very high rigidity system is created.



Fig. 2

DS

Fully extending telescopic rail consisting of a fixed guide rail, an identical moving guide rail, and an S-shaped intermediate element. This has a high moment of inertia and high rigidity in a slim size. This results in a high loading capacity with low deflection in the extended state.

The DS series is available in three different designs: DSS version with single direction stroke, DSB version with single direction stroke and locking capability in the closed position, and DSD version with double direction stroke. DS...S version available with reinforced and damped stainless steel end stops.



Fig. 3

DSE

Telescopic rail with a 150% extension of its length, made by four elements. It has a high rigidity, thanks to the intermediate elements with a high moment of inertia, in a streamlined shape.

This results in a high load capacity, with reduced bending even when the telescopic guide is fully extended.



Fig. 4

DSC

Fully extending telescopic rail consisting of a compact and flexurally rigid intermediate element that connects two different sized guide rails with each other as a fixed and moving element.

This design makes it possible to reduce all components to the necessary size and length for achieving the full stroke. The DSC series features high rigidity and a high load capacity in a compact size. This results in an optimal combination of performance and weight reduction.



Fig. 5

DE

Fully extending telescopic rail consisting of two guide rails, which are mounted on an I-beam profile to form the intermediate element, one moveable slider and one fixed slider which mounts onto the structure. The square cross-section allows a compact size with high load capacities and low deflection, especially with radial loading. Also available with a double stroke design, which includes an eccentrically located driving disc for simultaneous movement. For double sided extensions, a dedicated DE...D version is available with a driving disc.

DE...S version available with reinforced and damped stainless steel end stops.



Fig. 6

DBN

Fully extending telescopic rail consisting of two guide rails, one which is fixed to a structure, and one which is moveable, and two sliders which are mounted together and form the intermediate element. The size is similar to the DE series and offers good protection from contamination of the ballcage.



Fig. 7

DMS

Heavy load telescopic consisting of elements from the ASN series and an extremely rigid I-beam profile as the intermediate element. This fully extending telescopic rail is used to accept very heavy loads with low deflection.



Fig. 8

Overview product cross sections

> Partial extension guides

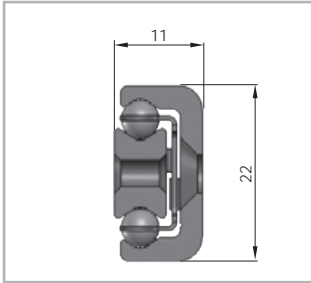

Fig. 9

ASN22

Load capacities p. TR-8

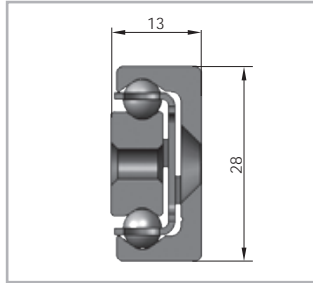

Fig. 10

ASN28

Load capacities p. TR-9

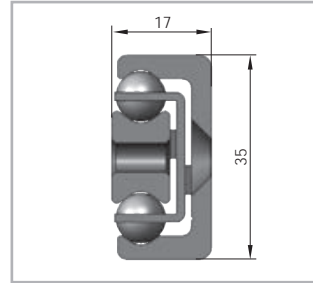

Fig. 11

ASN35

Load capacities p. TR-9

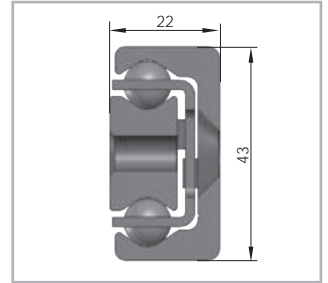

Fig. 12

ASN43

Load capacities p. TR-10

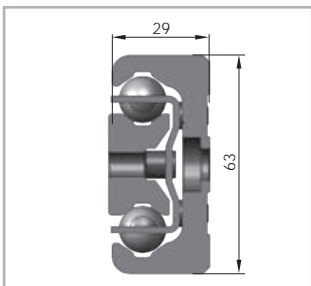

Fig. 13

ASN63

Load capacities p. TR-10

> Full extension guides

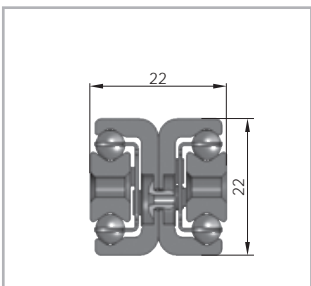

Fig. 14

DE22

Load capacities p. TR-23

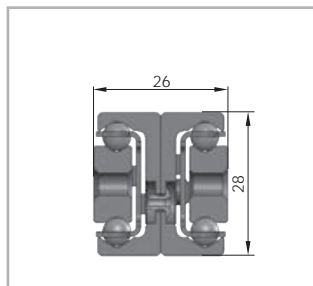

Fig. 15

DE28

Load capacities p. TR-23

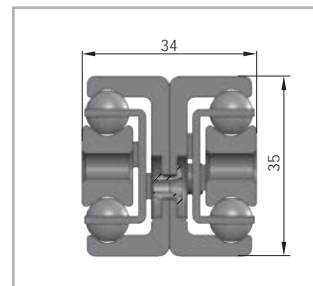

Fig. 16

DE35

Load capacities p. TR-24

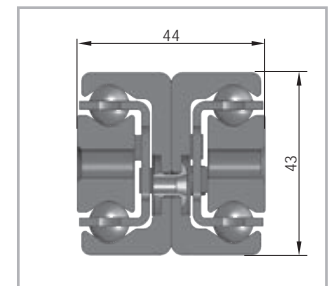

Fig. 17

DE43

Load capacities p. TR-24

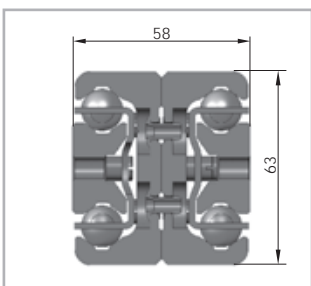

Fig. 18

DEF63

Load capacities p. TR-24

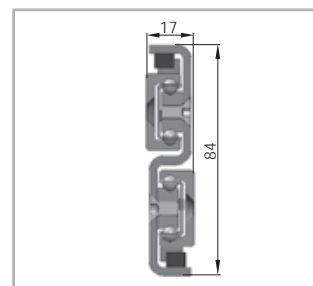

Fig. 19

DSS28

Load capacities p. TR-12

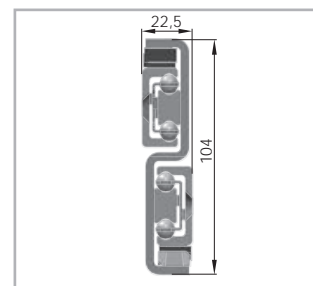

Fig. 20

DSS35

Load capacities p. TR-12

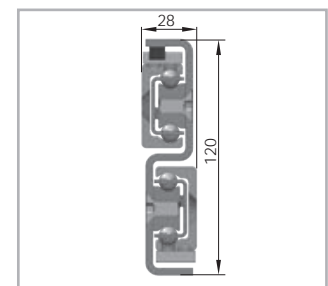

Fig. 21

DSS43

Load capacities p. TR-13

> Full extension guides

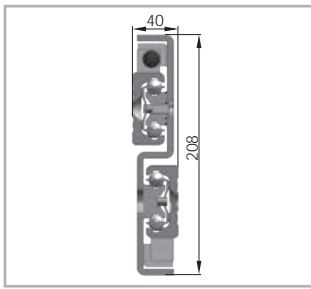

Fig. 22

DSS63

Load capacities p. TR-13

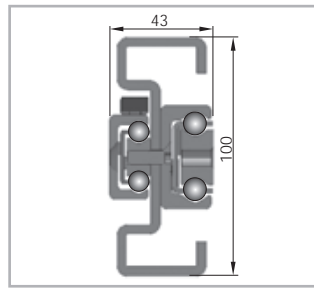

Fig. 23

DSC43

Load capacities p. TR-21

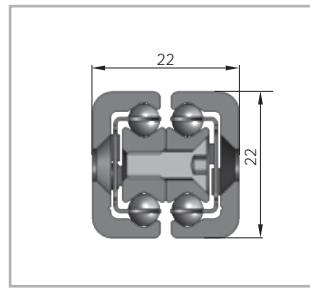

Fig. 24

DBN22

Load capacities p. TR-32

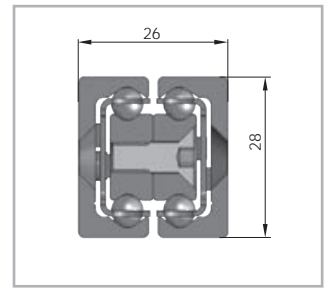

Fig. 25

DBN28

Load capacities p. TR-32

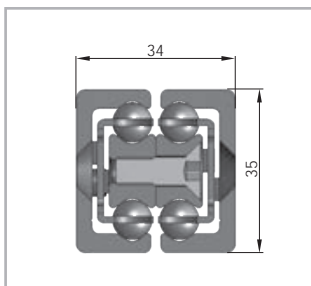

Fig. 26

DBN35

Load capacities p. TR-33

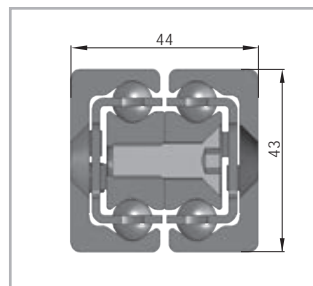

Fig. 27

DBN43

Load capacities p. TR-33

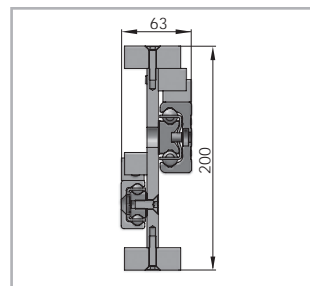

Fig. 28

DMS63

Load capacities p. TR-34

> Overextending guides

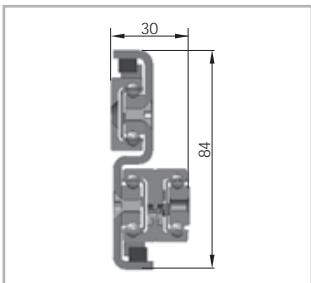

Fig. 29

DSE28

Load capacities p. TR-19

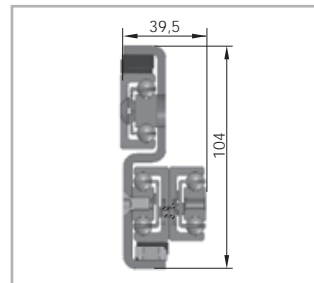

Fig. 30

DSE35

Load capacities p. TR-19

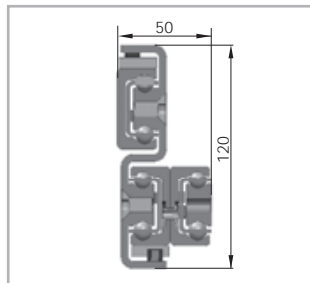

Fig. 31

DSE43

Load capacities p. TR-20

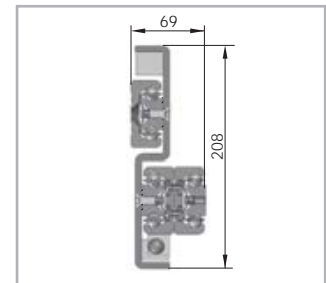

Fig. 32

DSE63

Load capacities p. TR-20

Technical data

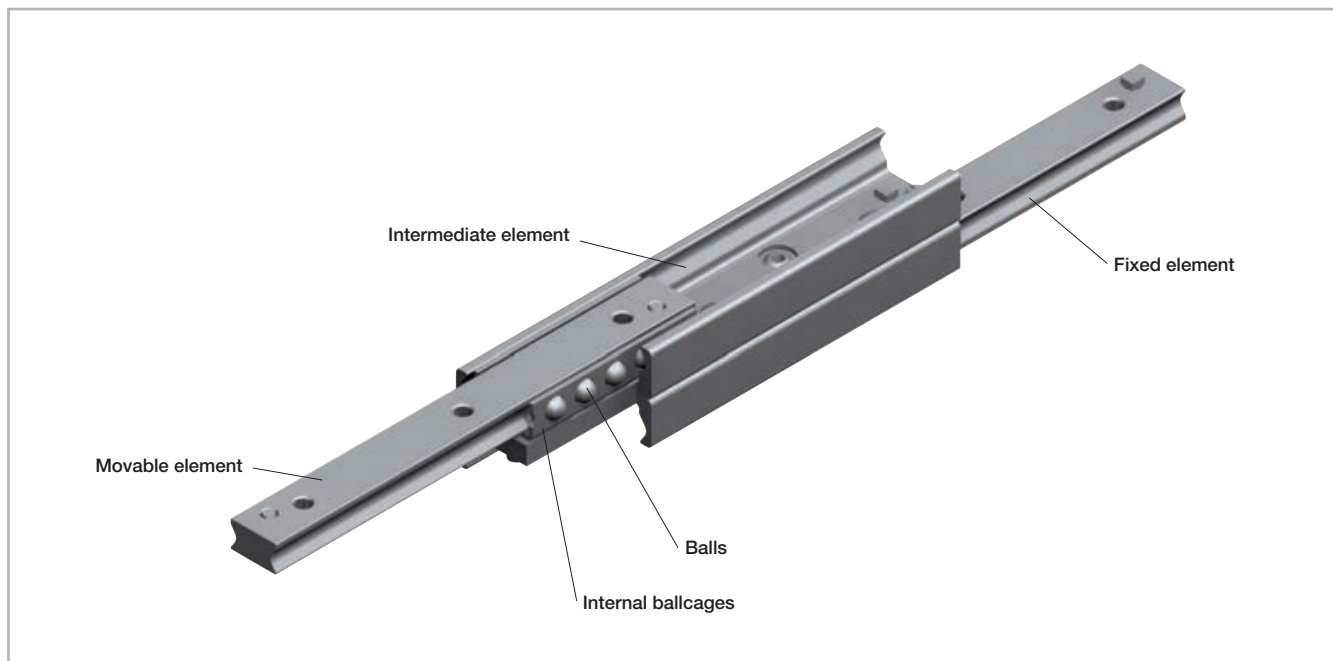

Fig. 33

Performance characteristics:

- Available sizes ASN / DE: 22, 28, 35, 43, 63
- Available sizes DS: 28, 35, 43, 63
- Available sizes DSE: 28, 35, 43, 63
- Available sizes DSC: 43
- Available sizes DBN: 22, 28, 35, 43
- Available size DMS: 63
- Induction hardened raceways
- Rails and sliders made of cold-drawn roller bearing carbon steel
- Balls made of hardened roller bearing carbon steel
- Max. operating speed: 0.8 m/s (31.5 in/s)
(depending on application)
- DE...S and DSS...S temperature range: -20°C to +50°C (-4°F to +122°F)
- ASN, DE, DBN, temperature range: -20 °C to +170 °C (-4 °F to +338 °F), DS, DSE, DSC and DMS: -20 °C to +80 °C (-4 °F to +176 °F)
- Electrolytic galvanised as per ISO 2081, increased anticorrosive protection on request (see pg. TR-43 Anticorrosive protection)

Remarks:

- All load capacity data are based on a pair of telescopic rails except the value M_x of ASN series (see pag. TR-8, TR-9, TR-10)
- Horizontal movement installation is recommended
- Vertical movement installation on request
- External end stops are recommended
- Double-sided stroke in ASN, DSD, DE, DBN series (DMS on request)
- Custom strokes on request
- All load capacity data is based on continuous operation
- Calculation of the service life is based exclusively on the loaded rows of balls
- For models DMS, DSB, and DSE, please observe right or left side use
- Fixing screws of property class 10.9 must be used for all telescopic rails
- Internal stops are used to stop the unloaded slider and the ball cage. Please use external stops as end stops for a loaded system

Dimensions and load capacity



> ASN

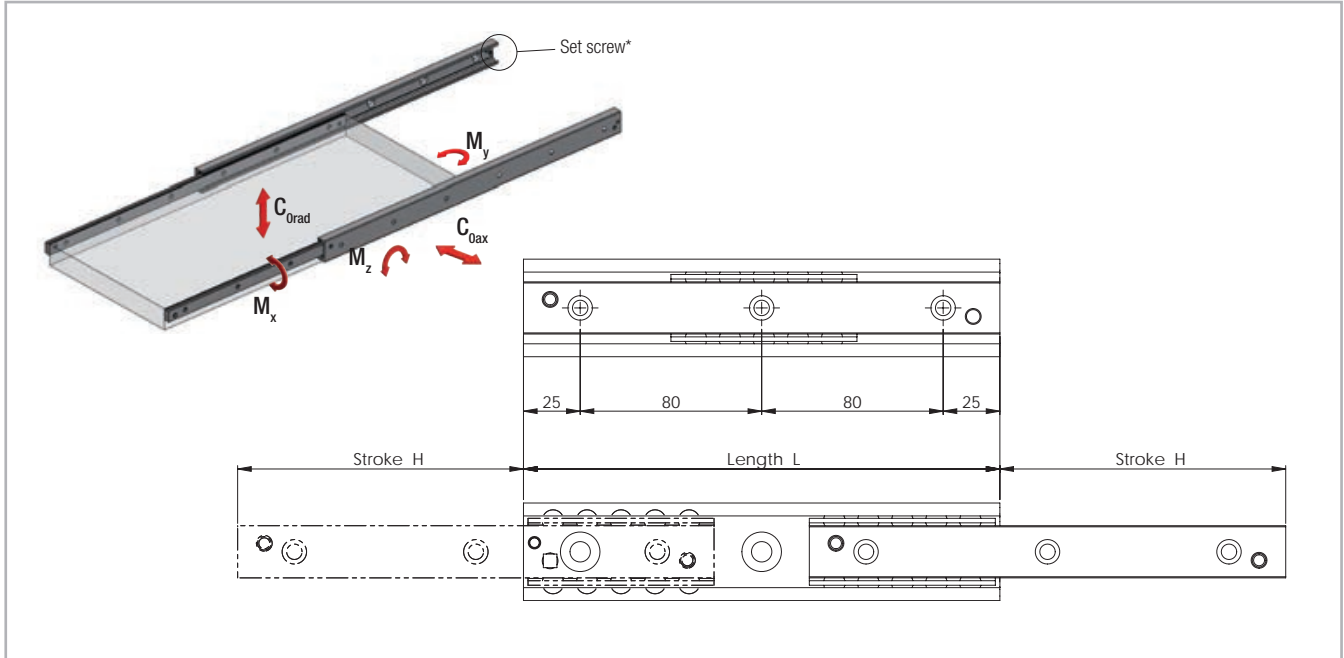

* Remove the set screw to reach all the fixing holes. See also assembly instructions on page TR-45f.

Fig. 34

Type	Size	Length L [mm]	Stroke H [mm]	Load capacity and moments for a pair of rails					No. of holes
				C_{0rad} [N]	C_{0ax} [N]	M_x^* [Nm]	M_y [Nm]	M_z [Nm]	
ASN	22	130	76	626	438	5.7	20	30	2
		210	111	1430	1002	10.7	72	102	3
		290	154	1988	1392	14.9	138	198	4
		370	196	2556	1790	19	226	324	5
		450	231	3402	2380	24	360	516	6
		530	274	3958	2770	28.2	496	710	7
		610	316	4524	3168	32.3	654	934	8
		690	351	5378	3764	37.3	872	1246	9
		770	394	5934	4154	41.5	1078	1538	10

* The value M_x refers to a single rail

Tab. 1

Type	Size	Length L [mm]	Stroke H [mm]	Load capacity and moments for a pair of rails					No. of holes
				C_{0rad} [N]	C_{0ax} [N]	M_x^* [Nm]	M_y [Nm]	M_z [Nm]	
ASN	28	130	74	1226	858	15.3	40	56	2
		210	116	2232	1562	26.1	114	164	3
		290	148	3868	2708	39.6	264	376	4
		370	190	4890	3422	50.4	426	610	5
		450	232	5910	4138	61.2	628	898	6
		530	274	6932	4852	72	870	1242	7
		610	316	7952	5566	82.8	1150	1642	8
		690	358	8974	6282	93.6	1470	2100	9
		770	400	9994	6996	104.4	1828	2612	10
		850	433	11656	8160	117.9	2330	3330	11
		930	475	12676	8872	128.7	2778	3968	12
		1010	517	13696	9586	139.5	3262	4660	13
		1090	559	14716	10300	150.3	3788	5410	14
1170	601	15736	11014	161.1	4350	6216	15		
ASN	35	210	127	2130	1492	29.4	114	164	3
		290	159	4120	2884	46.9	292	416	4
		370	203	5276	3694	59.9	476	680	5
		450	247	6434	4504	73	708	1010	6
		530	279	8564	5994	90.4	1086	1550	7
		610	323	9716	6802	103.5	1422	2030	8
		690	367	10870	7608	116.6	1804	2576	9
		770	399	13042	9130	134	2382	3404	10
		850	443	14190	9932	147.1	2870	4100	11
		930	487	15338	10736	160.2	3404	4862	12
		1010	519	17530	12272	177.6	4184	5978	13
		1090	563	18674	13072	190.7	4824	6890	14
		1170	607	19818	13874	203.8	5508	7868	15
		1250	639	22024	15416	221.2	6490	9272	16
		1330	683	23164	16214	234.3	7280	10400	17
1410	727	24306	17014	247.4	8116	11594	18		
1490	759	26520	18564	264.8	9300	13286	19		

* The value M_x refers to a single rail

Tab. 2

4 Dimensions and load capacity

Type	Size	Length L [mm]	Stroke H [mm]	Load capacity and moments for a pair of rails					No. of holes	
				C_{rad} [N]	C_{Oax} [N]	M_x^* [Nm]	M_y [Nm]	M_z [Nm]		
ASN	43	210	123	3190	2234	60.6	168	240	3	
		290	158	5744	4020	93.8	402	576	4	
		370	208	6754	4728	115.9	616	880	5	
		450	243	9380	6566	149.2	1018	1456	6	
		530	278	12078	8454	182.4	1524	2176	7	
		610	313	14822	10376	215.6	2128	3042	8	
		690	363	15726	11008	237.8	2588	3698	9	
		770	398	18464	12926	271	3362	4804	10	
		850	433	21230	14862	304.2	4238	6054	11	
		930	483	22108	15476	326.4	4878	6968	12	
		1010	518	24868	17408	359.6	5922	8460	13	
		1090	568	25754	18028	381.8	6674	9534	14	
		1170	603	28508	19956	415	7886	11266	15	
		1250	638	31276	21894	448.2	9198	13142	16	
		1330	688	32150	22504	470.4	10130	14472	17	
		1410	723	34912	24438	503.6	11612	16590	18	
		1490	758	37690	26382	536.8	13196	18850	19	
		1570	793	40476	28334	570.1	14880	21256	20	
		1650	843	41322	28926	592.2	16058	22940	21	
		1730	878	44104	30872	625.5	17912	25588	22	
		1810	928	44958	31472	647.6	19202	27432	23	
		1890	963	47734	33414	680.8	21224	30320	24	
		1970	1013	48596	34018	703	22628	32324	25	
		ASN	63	610	333	21182	14828	474	3106	4438
690	373			25068	17548	547.5	4144	5920	9	
770	413			28978	20284	621	5332	7616	10	
850	453			32904	23032	694.5	6668	9526	11	
930	493			36842	25790	768	8154	11648	12	
1010	533			40790	28554	841.4	9788	13984	13	
1090	573			44746	31322	914.9	11574	16534	14	
1170	613			48708	34096	988.4	13508	19296	15	
1250	653			52674	36872	1061.9	15590	22272	16	
1330	693			56644	39650	1135.4	17824	25462	17	
1410	733			60618	42432	1208.9	20204	28864	18	
1490	773			64594	45216	1282.4	22736	32480	19	
1570	813			68574	48002	1355.9	25416	36310	20	
1650	853			72554	50788	1429.4	28246	40352	21	
1730	893			76536	53576	1502.8	31226	44608	22	
1810	933			80522	56364	1576.3	34354	49078	23	
1890	973			84506	59154	1649.8	37632	53760	24	
1970	1013	88494	61946	1723.3	41060	58656	25			

Tab. 3

* The value M_x refers to a single rail

> ASN

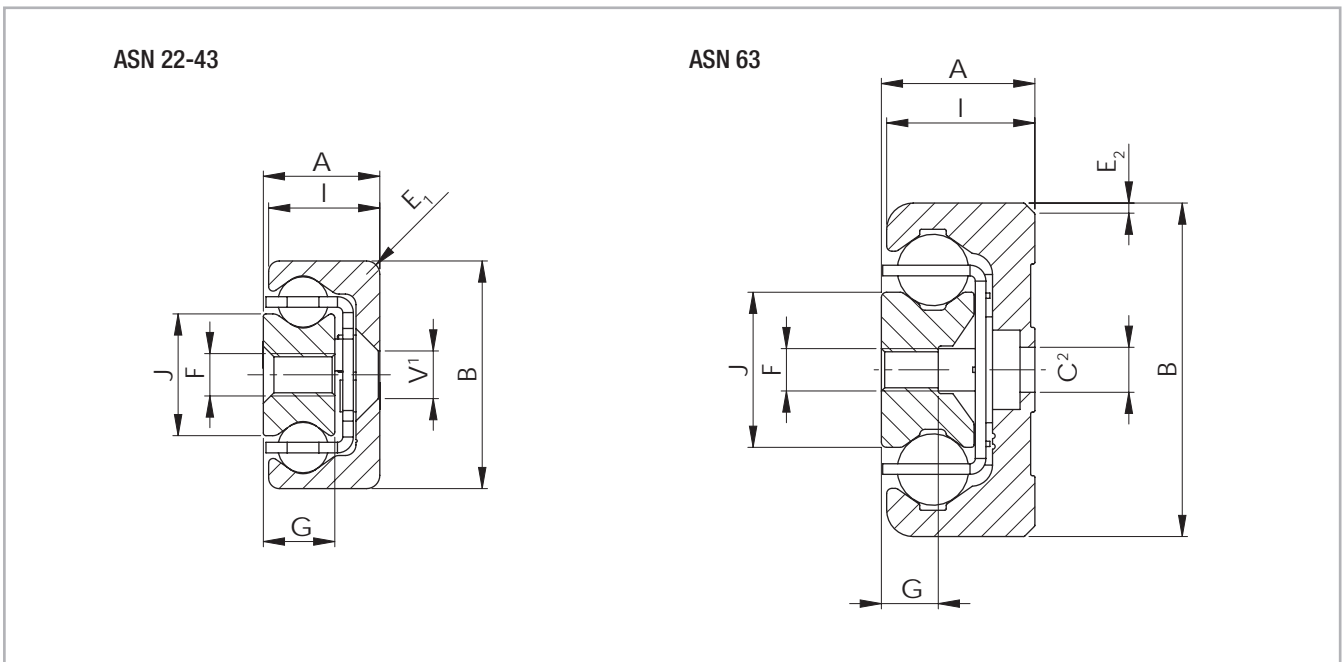

Fig. 35

¹ Fixing holes (V) for countersunk head screws according to DIN 7991

² Fixing holes (C) for socket cap screws according to DIN 7984. Alternative fixing with Torx® screws in special design with low head (on request)

Type	Size	Cross-section										Weight per single guide [kg/m]
		A [mm]	B [mm]	I [mm]	J [mm]	G [mm]	E ₁ [mm]	E ₂ [°]	V	C	F	
ASN	22	11	22	10.25	11.3	6.5	3	-	M4	-	M4	1.32
	28	13	28	12.25	15	7.5	1	-	M5	-	M5	2.02
	35	17	35	16	15.8	10	2	-	M6	-	M6	3.05
	43	22	43	21	23	13.5	2.5	-	M8	-	M8	5.25
	63	29	63	28	29.3	10.5	-	2 x 45	-	M8	M8	10.30

Tab. 4

> DSS

DSS with one-sided extension (single stroke)

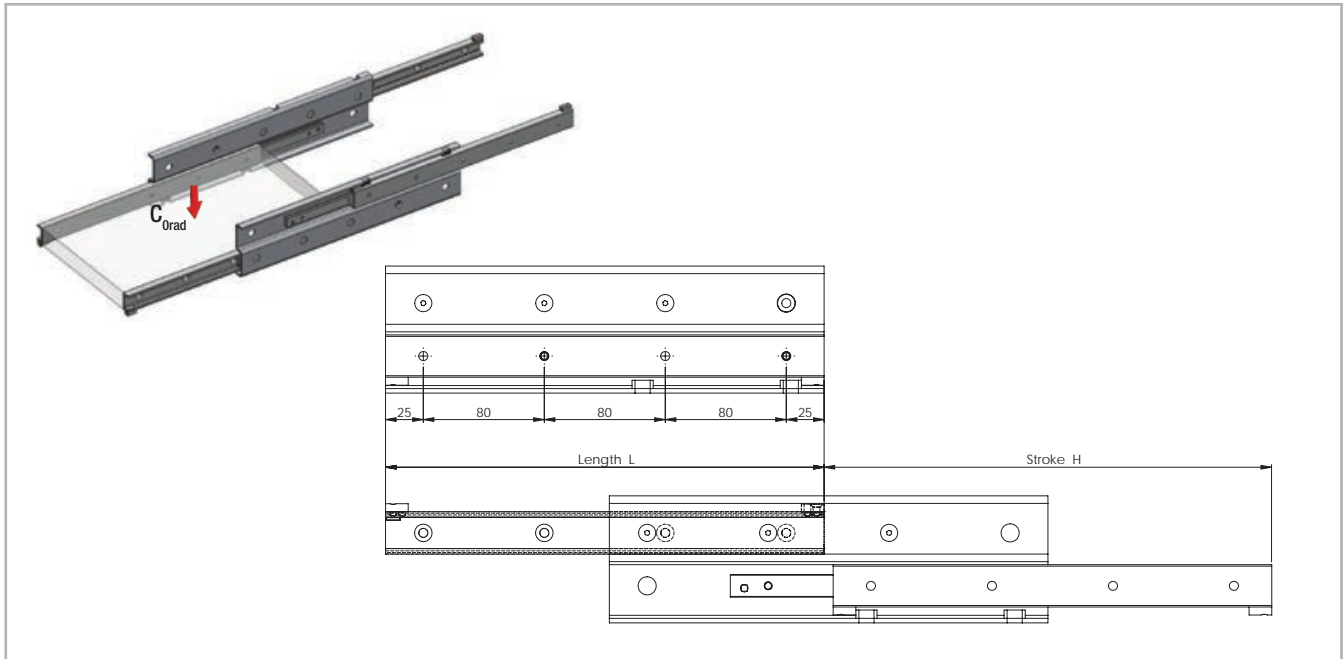

Fig. 36

Type	Size	Length L [mm]	Stroke H [mm]	Load capacity for a pair of rails C_{Orad} [N]	Accessible holes / total
DSS	28	290	296	1140	3 / 4
		370	380	1538	4 / 5
		450	464	1938	4 / 6
		530	548	2340	6 / 7
		610	630	2752	6 / 8
		690	714	3154	7 / 9
		770	798	3556	7 / 10
		850	864	4222	9 / 11
		930	950	4480	9 / 12
		1010	1034	4108	10 / 13
		1090	1118	3792	10 / 14
		1170	1202	3522	12 / 15
		1250	1266	3390	12 / 16
		1330	1350	3172	13 / 17
1410	1434	2980	13 / 18		
1490	1518	2810	15 / 19		

Tab. 5

Type	Size	Length L [mm]	Stroke H [mm]	Load capacity for a pair of rails C_{Orad} [N]	Accessible holes / total
DSS	35	450	494	2500	5 / 6
		530	558	3370	6 / 7
		610	646	3816	6 / 8
		690	734	4264	7 / 9
		770	798	5158	8 / 10
		850	886	5602	9 / 11
		930	974	6048	9 / 12
		1010	1038	6952	10 / 13
		1090	1126	7016	11 / 14
		1170	1214	6480	12 / 15
		1250	1278	6242	12 / 16
		1330	1366	5814	13 / 17
		1410	1454	5442	14 / 18
		1490	1518	5272	15 / 19
		1570	1606	4964	15 / 20
		1650	1694	4690	16 / 21
		1730	1758	4564	17 / 22

Tab. 6

Type	Size	Length L [mm]	Stroke H [mm]	Load capacity for a pair of rails C_{0rad} [N]	Accessible holes / total
DSS	43	530	556	4122	6 / 7
		610	626	5206	6 / 8
		690	726	5550	7 / 9
		770	796	6638	7 / 10
		850	866	7746	9 / 11
		930	966	8072	9 / 12
		1010	1036	9180	10 / 13
		1090	1106	10208	10 / 14
		1170	1206	9220	12 / 15
		1250	1276	8796	12 / 16
		1330	1376	8054	13 / 17
		1410	1446	7728	14 / 18
		1490	1516	7426	15 / 19
		1570	1616	6890	15 / 20
		1650	1686	6650	16 / 21
		1730	1756	6426	17 / 22
		1810	1856	6022	18 / 23
1890	1926	5838	18 / 24		
1970	2026	5500	19 / 25		

Tab. 7

Type	Size	Length L [mm]	Stroke H [mm]	Load capacity for a pair of rails C_{0rad} [N]	Accessible holes / total
DSS	63	610	666	7004	6 / 8
		690	746	8504	8 / 9
		770	826	10024	8 / 10
		850	906	11560	9 / 11
		930	986	13104	9 / 12
		1010	1066	14658	11 / 13
		1090	1146	16218	11 / 14
		1170	1226	17784	12 / 15
		1250	1306	19354	12 / 16
		1330	1386	20928	14 / 17
		1410	1466	22504	14 / 18
		1490	1546	24082	15 / 19
		1570	1626	25664	15 / 20
		1650	1706	24728	17 / 21
		1730	1786	23654	17 / 22
		1810	1866	22668	18 / 23
		1890	1946	21762	18 / 24
1970	2026	20926	20 / 25		

Tab. 8

> DSS

DSS with one-sided extension (single stroke)

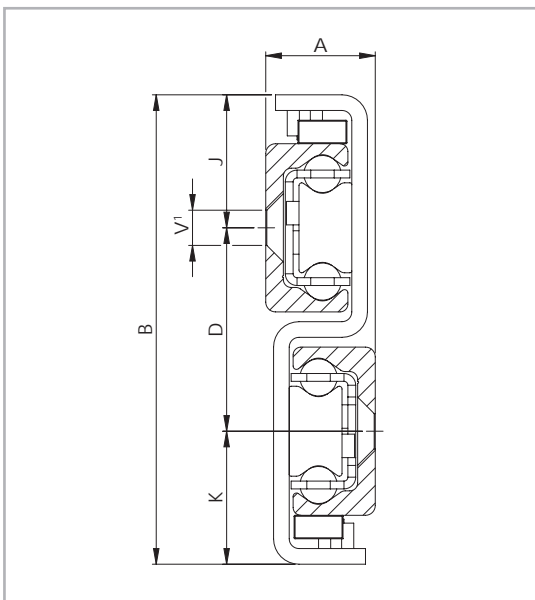

¹ Fixing holes (V) for countersunk head screws according to DIN 7991 Fig. 37

Type	Size	Cross-section						Weight per single guide [kg/m]
		A [mm]	B [mm]	K [mm]	D [mm]	J [mm]	V	
DSS	28	17	84	24.5	35	24.5	M5	6.40
	35	22.5	104	30.5	43	30.5	M6	10.10
	43	28	120	34	52	34	M8	14.60
	63	40	208	64	80	64	M10	32.60

Tab. 9

> DSS...S

... S-Version with reinforced and damped stainless steel limit blocks

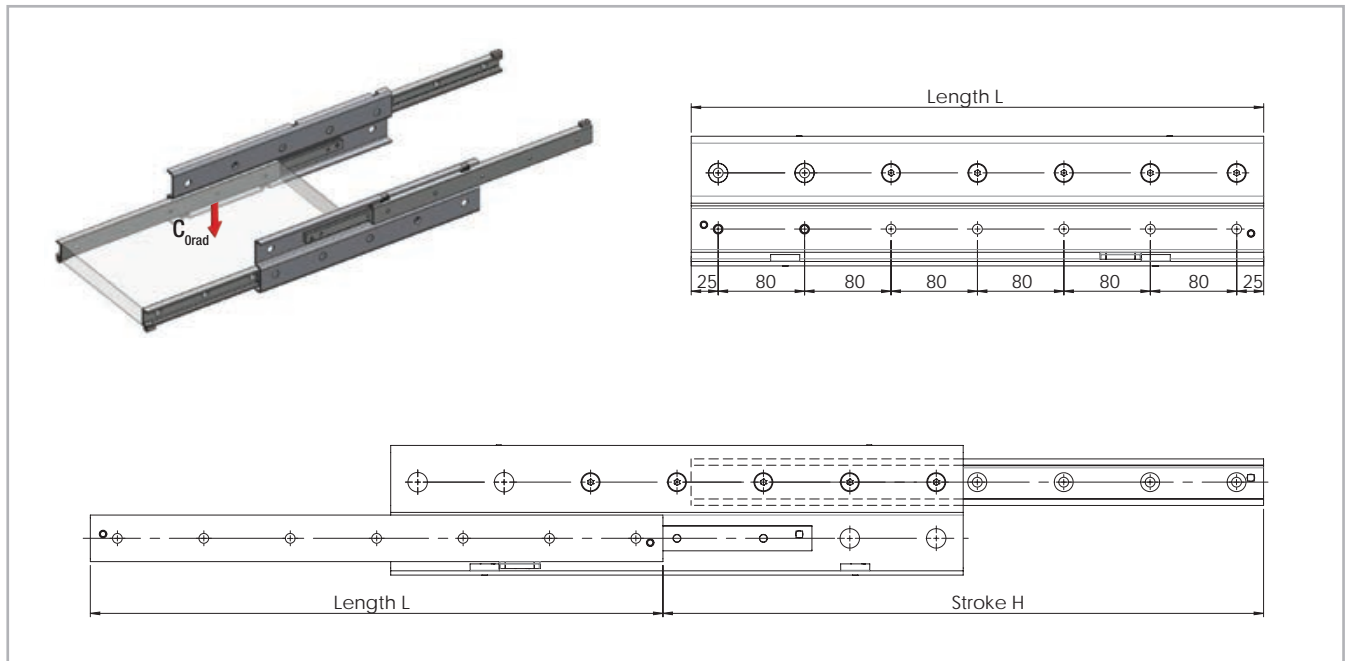

Fig. 38

Type	Size	Length L [mm]	Stroke H [mm]	Load capacity for a pair of rails C_{Orad} [N]	Accessible holes / total
DSS...S	43	530	556	4122	6 / 7
		610	626	5206	6 / 8
		690	726	5550	7 / 9
		770	796	6638	7 / 10
		850	866	7746	9 / 11
		930	966	8072	9 / 12
		1010	1036	9180	10 / 13
		1090	1106	10208	10 / 14
		1170	1206	9220	12 / 15
		1250	1276	8796	12 / 16
		1330	1376	8054	13 / 17
		1410	1446	7728	14 / 18
		1490	1516	7426	15 / 19
		1570	1616	6890	15 / 20
		1650	1686	6650	16 / 21
		1730	1756	6426	17 / 22
		1810	1856	6022	18 / 23
1890	1926	5838	18 / 24		
1970	2026	5500	19 / 25		

Tab. 10

> DSS...S

...S version with reinforced and damped stainless steel end stops

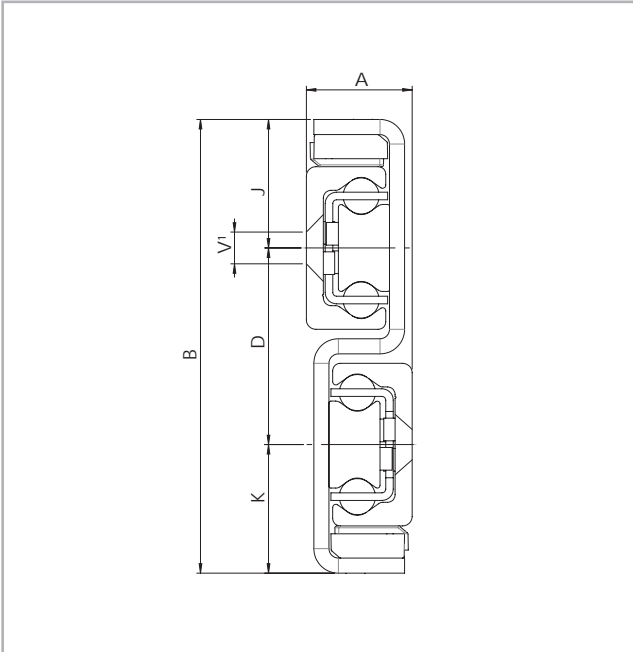

¹ Fixing holes (V) for countersunk head screws according to DIN 7991

Fig. 39

Type	Size	Cross-section						Weight per single guide [kg/m]
		A [mm]	B [mm]	K [mm]	D [mm]	J [mm]	V	
DSS...S	43	28	120	34	52	34	M8	14.60

Tab. 11

> DSB

B version with locking system for closed position

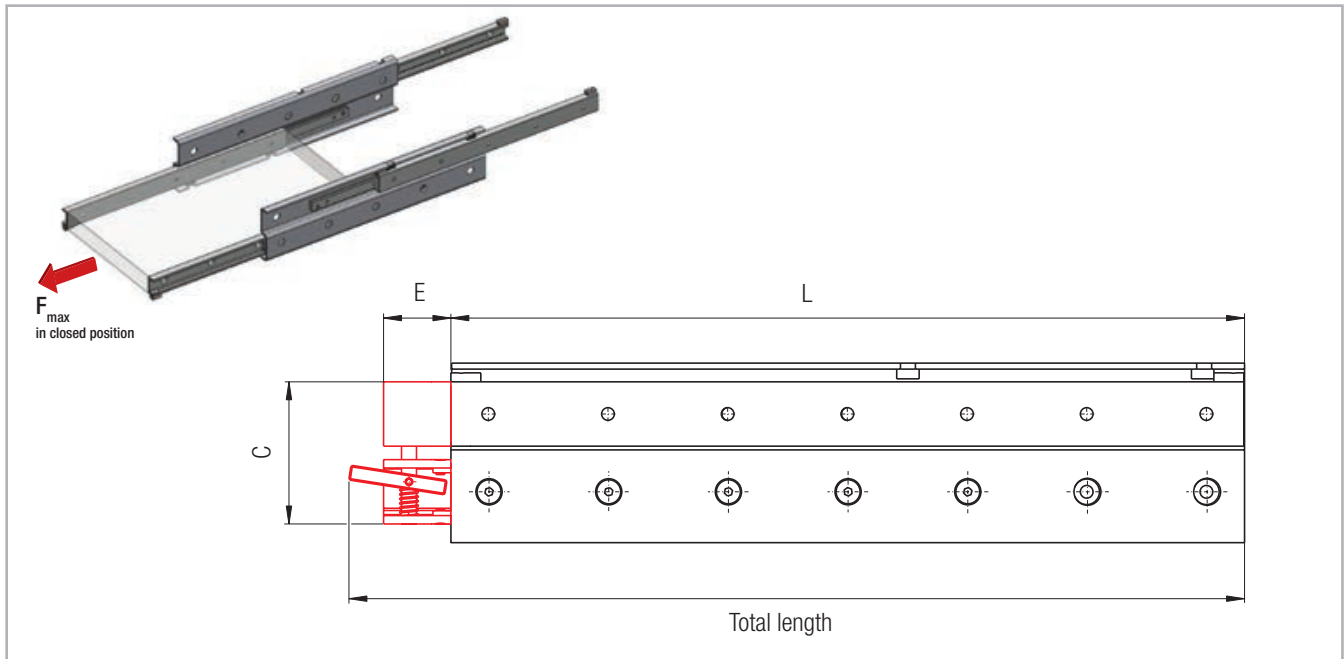

Fig. 40

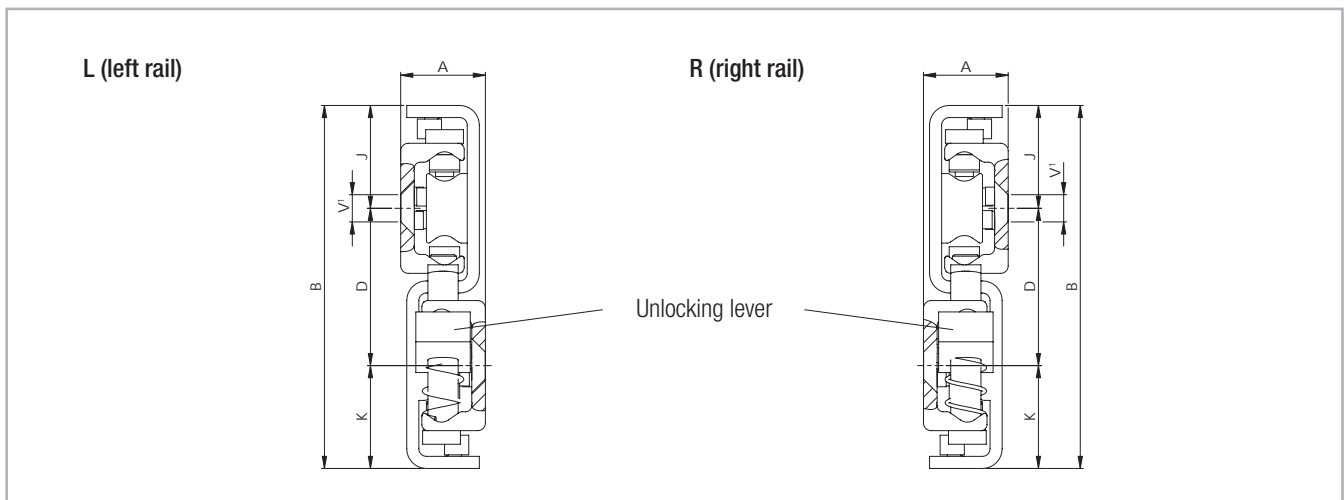

Fig. 41

¹ Fixing holes (V) for countersunk head screws according to DIN 7991

The DSB is built on the DSS design. The same load capacities, cross-sections and available rail lengths apply (see pg. TR-12ff). Data in Table 12 are based on the special features of the locking mechanism.

Please observe right or left installation for version DSB. The maximum load on the locking when closed is indicated by F_{max} .

Type	Size	L [mm]	Total length [mm]	C [mm]	E [mm]	F_{max}^{*2} [N]	Weight per single guide [kg/m]
DSB	28	from 290 to 1490*	L + 52	63	35	2460	6.51
	35	from 450 to 1730*	L + 53	78	33	3000	10.4
	43	from 530 to 1970*	L + 69	95	45	5630	14.98

* For available lengths, see pg. TR-12, tab. 5 and 7 (DSS)

^{*2} Value referred to one locking mechanism, for application we always suggest to have 2 rails both equipped with locking mechanism.

Tab. 12

> DSD

DSD with double direction stroke (double stroke)

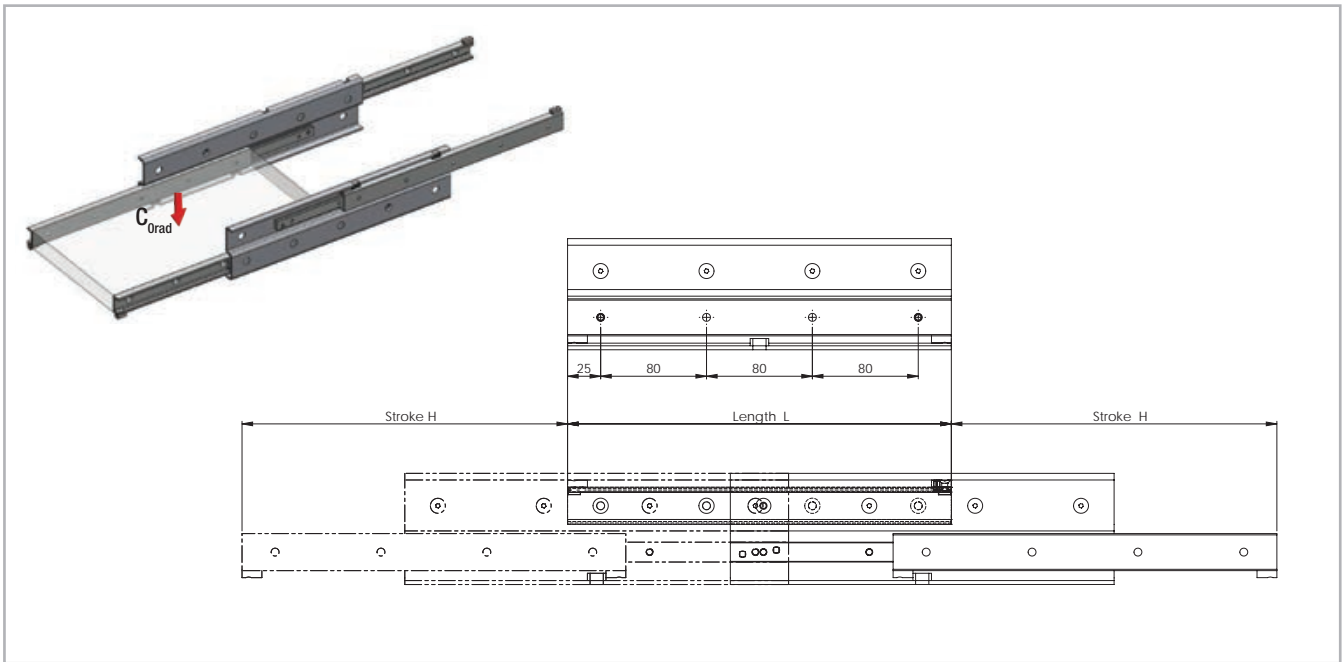

Fig. 42

Type	Size	Length L [mm]	Stroke H [mm]	Load capacity for a pair of rails C_{0rad} [N]	Accessible holes / total
DSD	28	290	246	1790	4 / 4
		370	326	2210	4 / 5
		450	406	2634	6 / 6
		530	486	3252	6 / 7
		610	566	3674	8 / 8
		690	646	4100	8 / 9
		770	726	4524	10 / 10
		850	806	4950	10 / 11
		930	886	5162	12 / 12
		1010	966	4714	12 / 13
		1090	1046	4336	14 / 14
		1170	1126	4016	14 / 15
		1250	1206	3740	16 / 16
		1330	1286	3498	16 / 17
1410	1366	3288	18 / 18		
1490	1446	3100	18 / 19		

Tab. 13

Type	Size	Length L [mm]	Stroke H [mm]	Load capacity for a pair of rails C_{0rad} [N]	Accessible holes / total
DSD	35	450	350	6050	4 / 6
		530	430	6382	6 / 7
		610	510	6762	6 / 8
		690	590	7600	8 / 9
		770	670	8016	8 / 10
		850	750	8446	10 / 11
		930	830	9292	10 / 12
		1010	910	9736	12 / 13
		1090	990	9160	12 / 14
		1170	1070	8404	14 / 15
		1250	1150	7764	14 / 16
		1330	1230	7214	16 / 17
		1410	1310	6738	16 / 18
		1490	1390	6320	18 / 19
		1570	1470	5950	18 / 20
		1650	1550	5622	20 / 21
		1730	1630	5328	20 / 22

Tab. 14

Type	Size	Length L [mm]	Stroke H [mm]	Load capacity for a pair of rails C_{Orad} [N]	Accessible holes / total
DSD	43	530	476	6036	6 / 7
		610	556	6530	8 / 8
		690	636	7562	8 / 9
		770	716	8594	10 / 10
		850	796	9094	10 / 11
		930	876	10126	12 / 12
		1010	956	11156	12 / 13
		1090	1036	11660	14 / 14
		1170	1116	10784	14 / 15
		1250	1196	10028	16 / 16
		1330	1276	9372	16 / 17
		1410	1356	8796	18 / 18
		1490	1436	8286	18 / 19
		1570	1516	7834	20 / 20
		1650	1596	7426	20 / 21
		1730	1676	7060	22 / 22
		1810	1756	6728	22 / 23
1890	1836	6426	24 / 24		
1970	1916	6150	24 / 25		

Tab. 15

Type	Size	Length L [mm]	Stroke H [mm]	Load capacity for a pair of rails C_{Orad} [N]	Accessible holes / total
DSD	63	610	398	23716	6 / 8
		690	478	24484	6 / 9
		770	558	25434	8 / 10
		850	638	26500	8 / 11
		930	718	27646	10 / 12
		1010	798	28848	10 / 13
		1090	878	30092	12 / 14
		1170	958	31368	12 / 15
		1250	1038	32668	14 / 16
		1330	1118	33988	14 / 17
		1410	1198	35322	16 / 18
		1490	1278	36670	16 / 19
		1570	1358	38018	18 / 20
		1650	1438	35538	18 / 21
		1730	1518	33360	20 / 22
		1810	1598	31436	20 / 23
		1890	1678	29720	22 / 24
1970	1758	28182	22 / 25		

Tab. 16

> DSD

DSD with double direction stroke (double stroke)

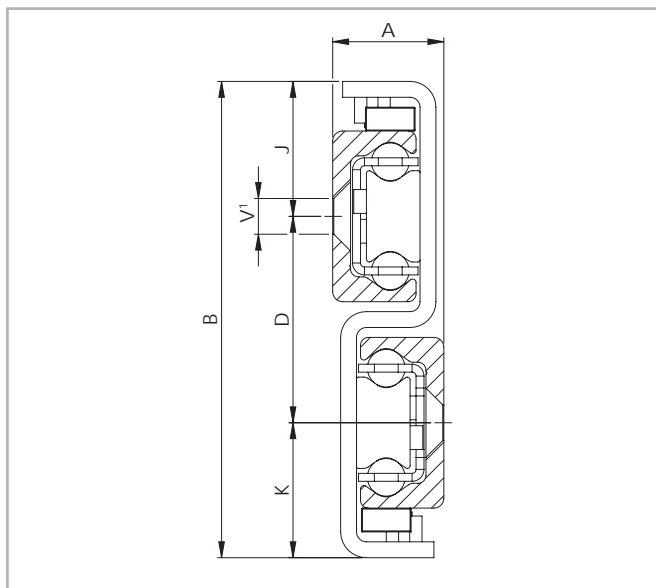

¹ Fixing holes (V) for countersunk head screws according to DIN 7991

Fig. 43

Type	Size	Cross-section						Weight per single guide [kg/m]
		A [mm]	B [mm]	K [mm]	D [mm]	J [mm]	V	
DSD	28	17	84	24.5	35	24.5	M5	6.40
	35	22.5	104	30.5	43	30.5	M6	10.10
	43	28	120	34	52	34	M8	14.60
	63	40	208	64	80	64	M10	32.60

Tab. 17

Please note the technical information "Double-sided stroke" on page TR-42

> DSE

E version with extra stroke

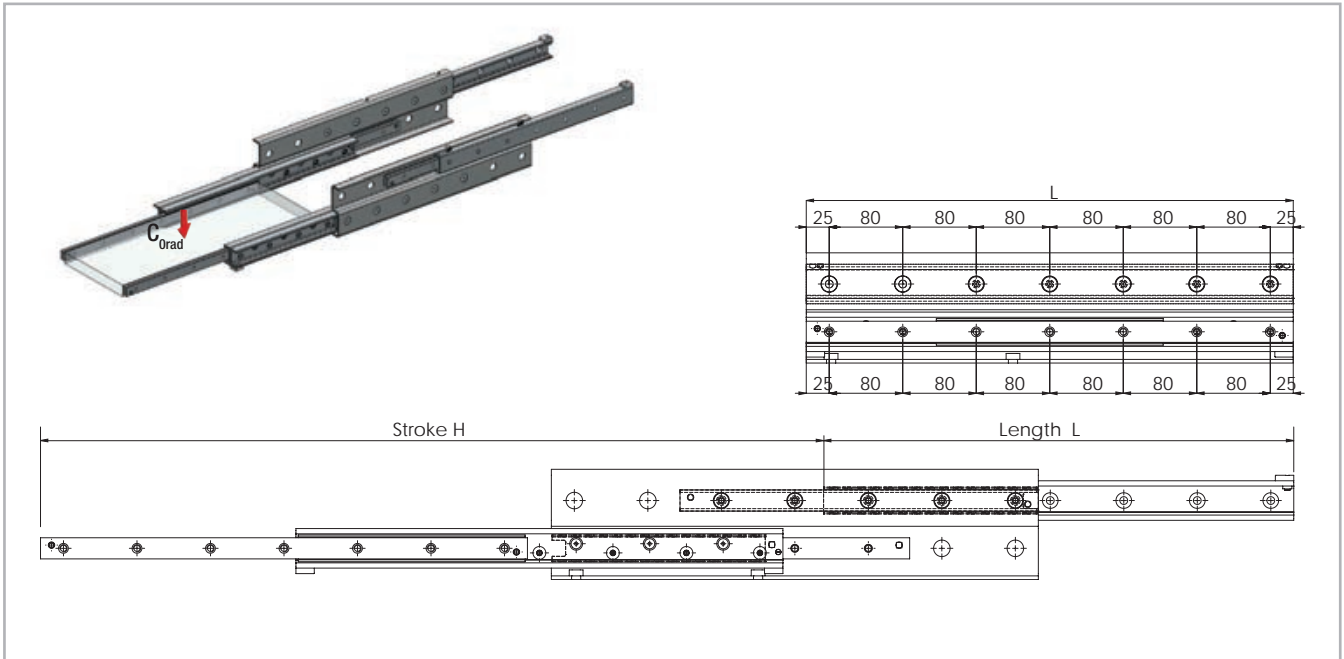

Fig. 44

Type	Size	Length L [mm]	Stroke H [mm]	Load capacity for a pair of rails C_{0rad} [N]	No. of holes fixed part	No. of holes mobile part
DSE	28	290	444	702	3 / 4	4
		370	570	952	4 / 5	5
		450	696	1200	4 / 6	6
		530	822	1450	6 / 7	7
		610	946	1702	6 / 8	8
		690	1072	1684	7 / 9	9
		770	1198	1506	7 / 10	10
		850	1297	1420	9 / 11	11
		930	1425	1292	9 / 12	12
		1010	1551	1184	10 / 13	13
		1090	1677	1094	10 / 14	14
		1170	1803	1016	12 / 15	15

Tab. 18

Type	Size	Length L [mm]	Stroke H [mm]	Load capacity for a pair of rails C_{0rad} [N]	No. of holes fixed part	No. of holes mobile part
DSE	35	450	741	1552	5 / 6	6
		530	837	2098	6 / 7	7
		610	969	2376	6 / 8	8
		690	1101	2652	7 / 9	9
		770	1197	3182	8 / 10	10
		850	1329	2850	9 / 11	11
		930	1461	2582	9 / 12	12
		1010	1557	2466	10 / 13	13
		1090	1689	2262	11 / 14	14
		1170	1821	2090	12 / 15	15
		1250	1917	2012	12 / 16	16
		1330	2049	1874	13 / 17	17
		1410	2181	1754	14 / 18	18
		1490	2277	1700	15 / 19	19

Tab. 19

Type	Size	Length L [mm]	Stroke H [mm]	Load capacity for a pair of rails C_{Orad} [N]	No. of holes fixed part	No. of holes mobile part
DSE	43	530	834	2582	6 / 7	7
		610	939	3264	6 / 8	8
		690	1089	3470	7 / 9	9
		770	1194	4154	7 / 10	10
		850	1299	4852	9 / 11	11
		930	1449	5012	9 / 12	12
		1010	1554	4728	10 / 13	13
		1090	1659	4476	11 / 14	14
		1170	1809	4044	12 / 15	15
		1250	1914	3856	12 / 16	16
		1330	2064	3532	13 / 17	17
		1410	2169	3388	13 / 18	18
		1490	2274	3256	15 / 19	19
		1570	2409	3078	15 / 20	20
		1650	2529	2916	16 / 21	21
		1730	2634	2818	16 / 22	22
		1810	2784	2640	18 / 23	23
1890	2889	2560	18 / 24	24		
1970	3039	2412	19 / 25	25		

Tab. 20

Type	Size	Length L [mm]	Stroke H [mm]	Load capacity for a pair of rails C_{Orad} [N]	No. of holes fixed part	No. of holes mobile part
DSE	63	610	999	4328	6 / 8	8
		690	1119	5260	8 / 9	9
		770	1239	6208	8 / 10	10
		850	1359	7164	9 / 11	11
		930	1479	8128	9 / 12	12
		1010	1599	9096	11 / 13	13
		1090	1719	10070	11 / 14	14
		1170	1839	11046	12 / 15	15
		1250	1959	11344	12 / 16	16
		1330	2079	10714	14 / 17	17
		1410	2199	10152	14 / 18	18
		1490	2319	9644	15 / 19	19
		1570	2439	9186	15 / 20	20
		1650	2559	8768	17 / 21	21
		1730	2679	8388	17 / 22	22
		1810	2799	8038	18 / 23	23
		1890	2919	7718	18 / 24	24
		1970	3039	7420	20 / 25	25

Tab. 21

> DSE

E version with extra stroke

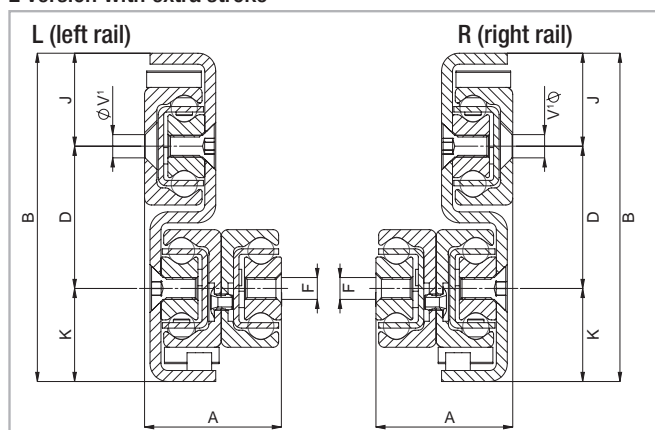

Fig. 45

¹ Fixing holes (V) for countersunk head screws according to DIN 7991
Please observe right or left installation for version DSE.

Type	Size	Cross-section							Weight per single guide [kg/m]
		A [mm]	B [mm]	K [mm]	D [mm]	J [mm]	F	V ¹	
DSE	28	30	84	24.5	35	24.5	M5	M5	8.4
	35	39.5	104	30.5	43	30.5	M6	M6	13.2
	43	50	120	34	52	34	M8	M8	19.9
	63	69	208	64	80	64	M8	M10	42.9

Tab. 22

> DSC

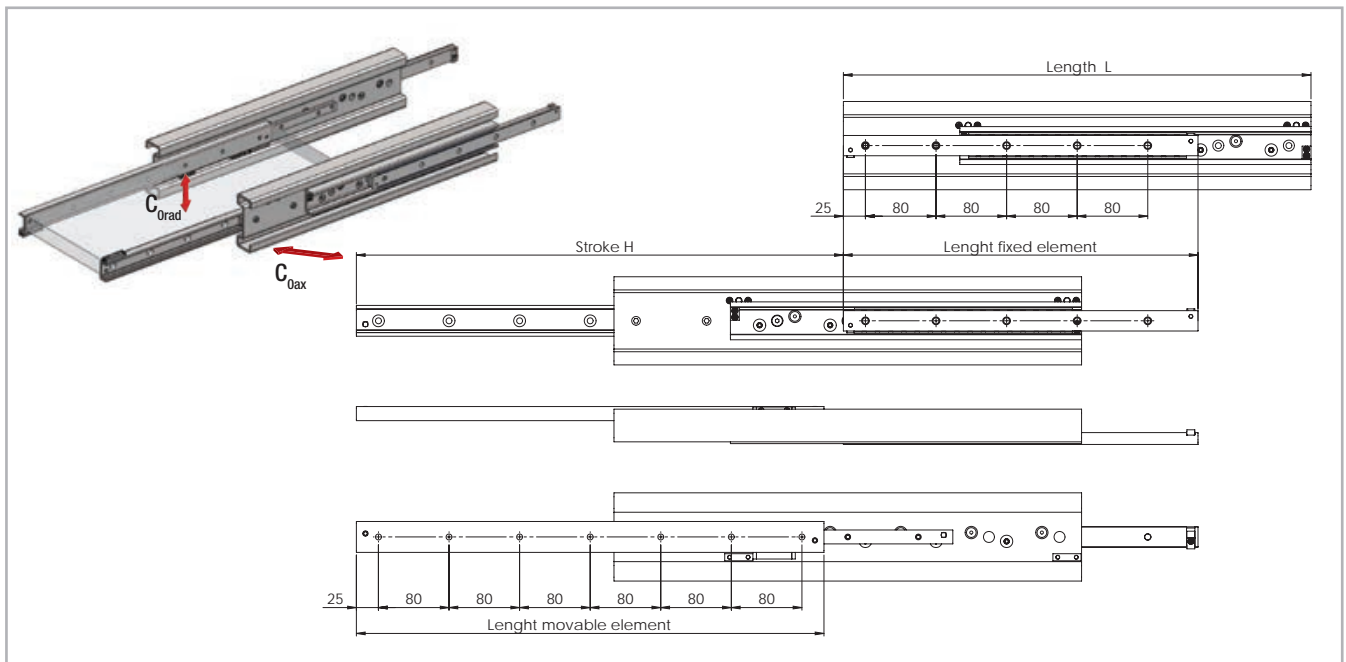
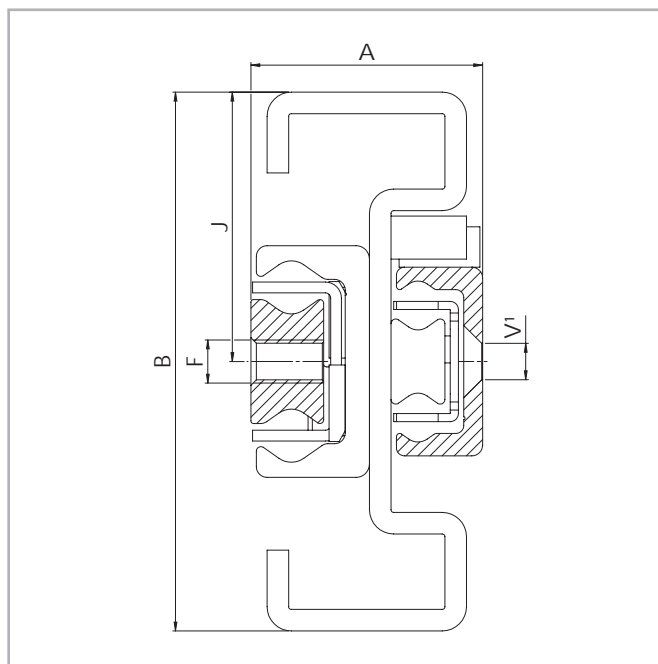

Fig. 46

Type	Size	Length L [mm]	Stroke H [mm]	Load capacity for a pair of rails		Fixed element		Movable element	
				C_{Orad} [N]	C_{Oax} [N]	Accessible holes / total	Length [mm]	Accessible holes / total	Length [mm]
DSC	43	530	550	4780	3346	5 / 5	402	6 / 7	530
		610	618	5928	4150	6 / 6	465	6 / 8	610
		690	724	6190	3724	6 / 6	520	8 / 9	690
		770	790	7332	3476	7 / 7	582	8 / 10	770
		850	856	8492	3260	8 / 8	644	9 / 11	850
		930	964	8738	2830	9 / 9	700	9 / 12	930
		1010	1028	10506	2700	10 / 10	770	11 / 13	1010
		1090	1098	11056	2554	10 / 10	825	11 / 14	1090
		1170	1200	10268	2294	11 / 11	887	12 / 15	1170
		1250	1270	9792	2186	12 / 12	942	12 / 16	1250
		1330	1374	8924	1992	13 / 13	1005	14 / 17	1330
		1410	1444	8562	1912	14 / 14	1060	14 / 18	1410
		1490	1508	8292	1852	14 / 14	1130	15 / 19	1490
		1570	1614	7634	1704	15 / 15	1185	16 / 20	1570
		1650	1684	7366	1646	15 / 15	1240	16 / 21	1650
		1730	1750	7142	1596	16 / 16	1302	17 / 22	1730
		1810	1842	6754	1508	17 / 17	1365	18 / 23	1810
1890	1920	6484	1448	18 / 18	1427	19 / 24	1890		
1970	2026	6074	1356	19 / 19	1482	20 / 25	1970		

Tab. 23

> DSC



¹ Fixing holes (V) for countersunk head screws according to DIN 7991

Fig. 47

Type	Size	Cross-section					Weight per single guide [kg/m]
		A [mm]	B [mm]	J [mm]	F [mm]	V' [mm]	
DSC	43	43	100	50	M8	M6	13.4

Tab. 24

> DE

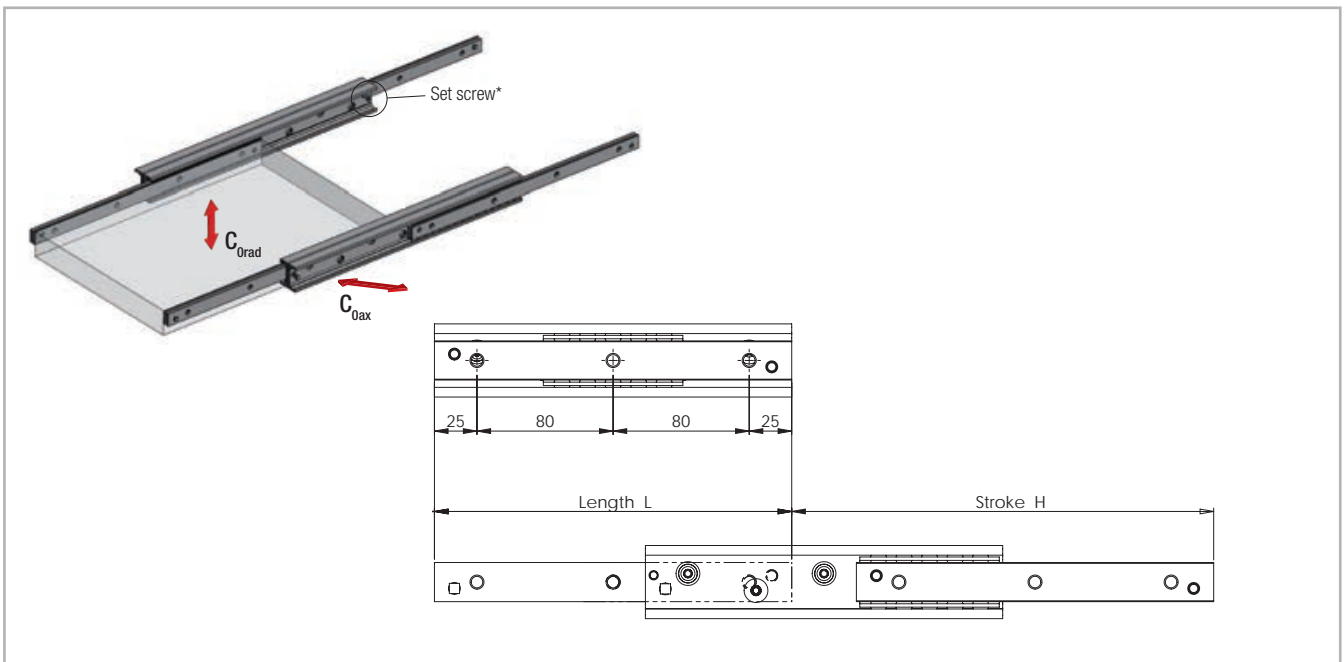

* Remove the set screw to reach all the fixing holes. See also assembly instructions on page TR-45f.

Fig. 48

Type	Size	Length L [mm]	Stroke H [mm]	Load capacity for a pair of rails		No. of holes
				C _{0rad} [N]	C _{0ax} [N]	
DEF DEV DEM	22	130	152	238	166	2
		210	222	562	392	3
		290	308	780	546	4
		370	392	1002	526	5
		450	462	1348	460	6
		530	548	1142	386	7
		610	632	988	334	8
		690	702	906	306	9
		770	788	802	270	10

Tab. 25

Type	Size	Length L [mm]	Stroke H [mm]	Load capacity for a pair of rails		No. of holes
				C _{0rad} [N]	C _{0ax} [N]	
DEF DEV DEM	28	130	148	470	328	2
		210	232	864	604	3
		290	296	1534	1074	4
		370	380	1936	942	5
		450	464	2338	770	6
		530	548	2214	650	7
		610	633	1910	560	8
		690	717	1684	494	9
		770	801	1506	442	10
		850	866	1420	416	11
		930	950	1292	378	12
		1010	1034	1184	348	13
		1090	1118	1094	320	14
		1170	1202	1016	298	15

Tab. 26

4 Dimensions and load capacity

Type	Size	Length L [mm]	Stroke H [mm]	Load capacity for a pair of rails		No. of holes
				C _{Orad} [N]	C _{Oax} [N]	
DEF DEV DEM	35	210	254	804	562	3
		290	318	1600	1120	4
		370	406	2050	1436	5
		450	494	2500	1586	6
		530	558	3370	1456	7
		610	646	3816	1252	8
		690	734	3378	1096	9
		770	798	3182	1032	10
		850	886	2850	926	11
		930	974	2582	838	12
		1010	1038	2466	800	13
		1090	1126	2262	734	14
		1170	1214	2090	678	15
		1250	1278	2012	654	16
		1330	1366	1874	608	17
		1410	1454	1754	570	18
		1490	1518	1700	552	19

Tab. 27

Type	Size	Length L [mm]	Stroke H [mm]	Load capacity for a pair of rails		No. of holes
				C _{Orad} [N]	C _{Oax} [N]	
DEF	63	610	666	8180	5726	8
		690	746	9718	6124	9
		770	826	11270	5568	10
		850	906	12830	5106	11
		930	986	14396	4714	12
		1010	1066	13770	4378	13
		1090	1146	12854	4086	14
		1170	1226	12052	3832	15
		1250	1306	11344	3606	16
		1330	1386	10714	3406	17
		1410	1466	10152	3228	18
		1490	1546	9644	3066	19
		1570	1626	9186	2920	20
		1650	1706	8768	2788	21
		1730	1786	8388	2666	22
		1810	1866	8038	2556	23
		1890	1946	7718	2454	24
		1970	2026	7420	2360	25

Tab. 29

Type	Size	Length L [mm]	Stroke H [mm]	Load capacity for a pair of rails		No. of holes
				C _{Orad} [N]	C _{Oax} [N]	
DEF DEV DEM	43	210	246	1210	848	3
		290	316	2228	1560	4
		370	416	2600	1820	5
		450	486	3656	2558	6
		530	556	4750	2868	7
		610	626	5868	2600	8
		690	726	6182	2192	9
		770	796	6110	2032	10
		850	866	5694	1892	11
		930	966	5012	1666	12
		1010	1036	4728	1572	13
		1090	1106	4476	1488	14
		1170	1206	4044	1344	15
		1250	1276	3856	1282	16
		1330	1376	3532	1174	17
		1410	1446	3388	1126	18
		1490	1516	3256	1082	19
		1570	1586	3134	1042	20
		1650	1686	2916	970	21
		1730	1756	2818	936	22
		1810	1856	2640	878	23
		1890	1926	2560	850	24
		1970	2026	2412	802	25

Tab. 28

> DE

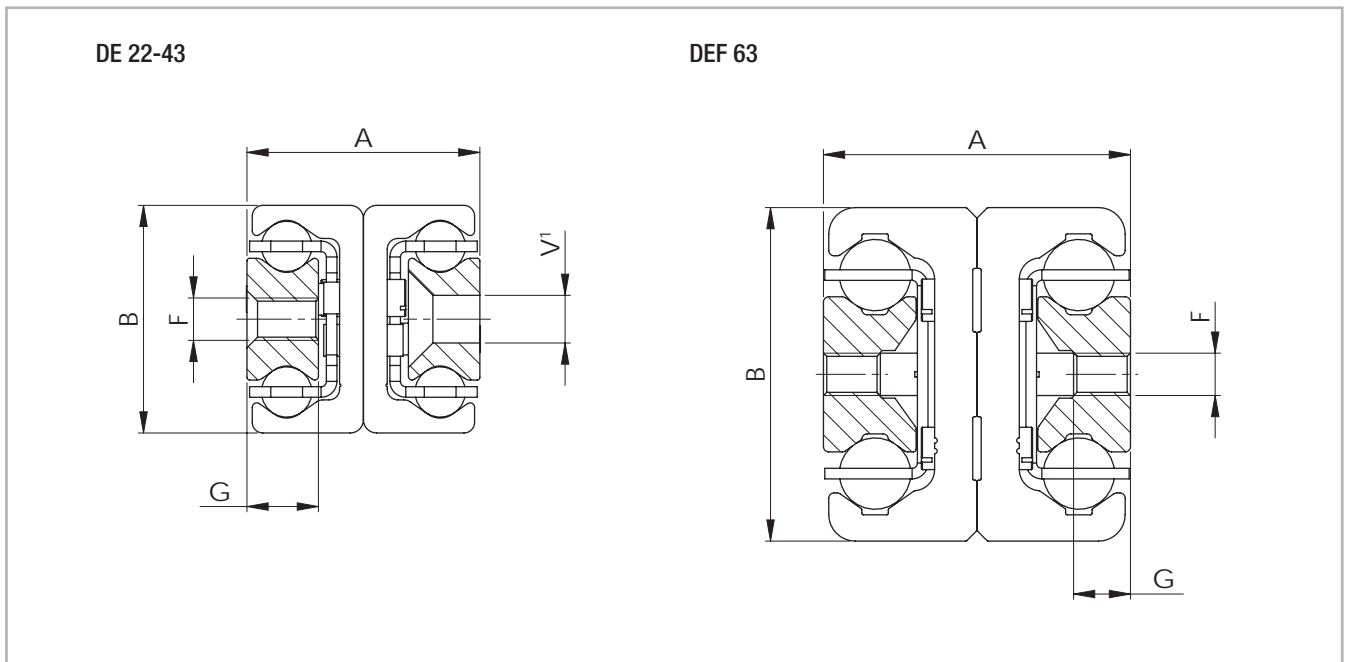

¹ Fixing holes (V) for countersunk head screws according to DIN 7991

Fig. 49

Type	Size	Cross-section					Weight per single guide [kg/m]
		A [mm]	B [mm]	G [mm]	F	V	
DEF DEV DEM	22	22	22	6.5	M4	M4	2.64
	28	26	28	7.5	M5	M5	4.04
	35	34	35	10	M6	M6	6.10
	43	44	43	13.5	M8	M8	10.50
	63	58	63	10.5	M8	-	20.60

Tab. 30

Please note the technical information "Double-sided stroke" on page TR-42

There are three options for mounting holes available for the DE series in sizes 22 to 43:

Version DEF with threaded holes,

Version DEV with counter-sunk holes,

Version DEM, both variants (mixed) (see fig. 52).

Size 63 is only available with threaded holes.

> DE...S

...S version with reinforced and damped stainless steel end stops

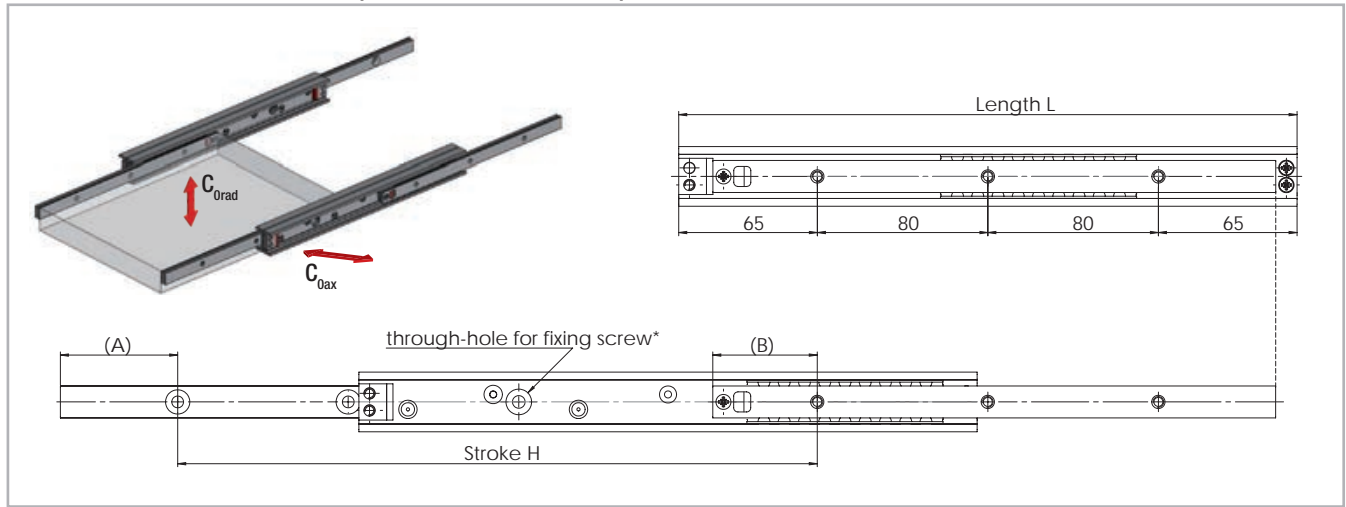

Fig. 50

Type	Size	Length L [mm]	Stroke H [mm]	Load capacity for a pair of rails		Slider [mm]	A [mm]	B [mm]	No of holes
				C _{Orad} [N]	C _{Oax} [N]				
DE...S	28	290	300	704	494	264	55	49	3
		370	384	1084	758	344			4
		450	468	1470	756	424			5
		530	533	2100	686	504			6
		610	636	1892	556	584			7
		690	701	1760	516	664			8
		770	804	1494	438	744			9
		850	850	1474	432	824			10
		930	953	1284	376	904			11
		1010	1018	1222	358	984			12
		1090	1102	1124	330	1064			13
		1170	1186	1042	306	1144			14

Tab. 31

Type	Size	Length L [mm]	Stroke H [mm]	Load capacity for a pair of rails		Slider [mm]	A [mm]	B [mm]	No of holes
				C _{Orad} [N]	C _{Oax} [N]				
DE...S	35	370	370	1430	1000	338	53	45	4
		450	464	1788	1252	418			5
		530	536	2476	1574	498			6
		610	630	2832	1312	578			7
		690	702	3540	1194	658			8
		770	796	3198	1038	738			9
		850	868	2966	962	818			10
		930	962	2644	858	898			11
		1010	1012	2592	842	978			12
		1090	1128	2254	732	1058			13
		1170	1178	2216	720	1138			14
		1250	1272	2030	660	1218			15
		1330	1344	1936	628	1298			16
		1410	1438	1792	582	1378			17
		1490	1510	1718	558	1458			18

Tab. 32

Type	Size	Length L [mm]	Stroke H [mm]	Load capacity for a pair of rails		Slider [mm]	A [mm]	B [mm]	No of holes
				C_{0rad} [N]	C_{0ax} [N]				
DE...S	43	370	366	2014	1410	338	53	45	4
		450	496	1864	1306	418			5
		530	536	3418	2394	498			6
		610	636	3796	2522	578			7
		690	706	4838	2312	658			8
		770	806	5206	1982	738			9
		850	846	5964	1982	818			10
		930	976	4914	1634	898			11
		1010	1016	4914	1634	978			12
		1090	1116	4398	1462	1058			13
		1170	1186	4178	1390	1138			14
		1250	1286	3798	1262	1218			15
		1330	1326	3798	1262	1298			16
		1410	1456	3344	1112	1378			17
		1490	1496	3344	1112	1458			18
		1570	1596	3096	1030	1538			19
		1650	1666	2986	992	1618			20
		1730	1766	2786	926	1698			21
		1810	1806	2786	926	1778			22
		1890	1936	2534	842	1858			23
		1970	2066	2322	772	1938			24

Tab. 33

> DE...S

...S version with reinforced and damped stainless steel end stops

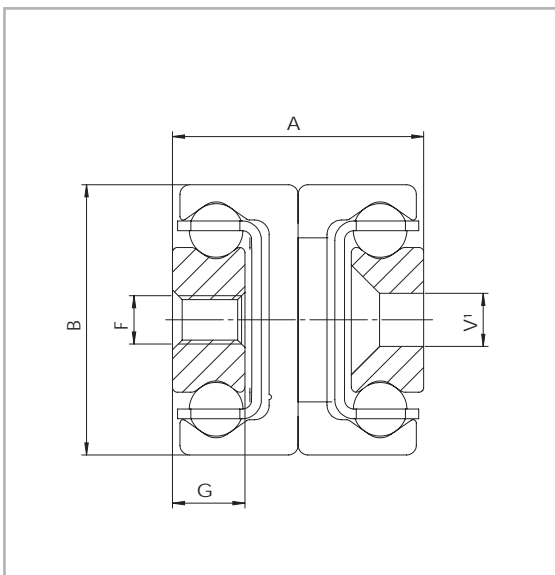

¹ Fixing holes (V) for countersunk head screws according to DIN 7991 Fig. 51

Type	Size	Cross-section					Weight per single guide [kg/m]
		A [mm]	B [mm]	G [mm]	F	V	
DE...S	28	26	28	7.5	M5	M5	4.04
	35	34	35	10	M6	M6	6.10
	43	44	43	13.5	M8	M8	10.50

Tab. 34

> DE...D

DED with double direction stroke (double stroke)

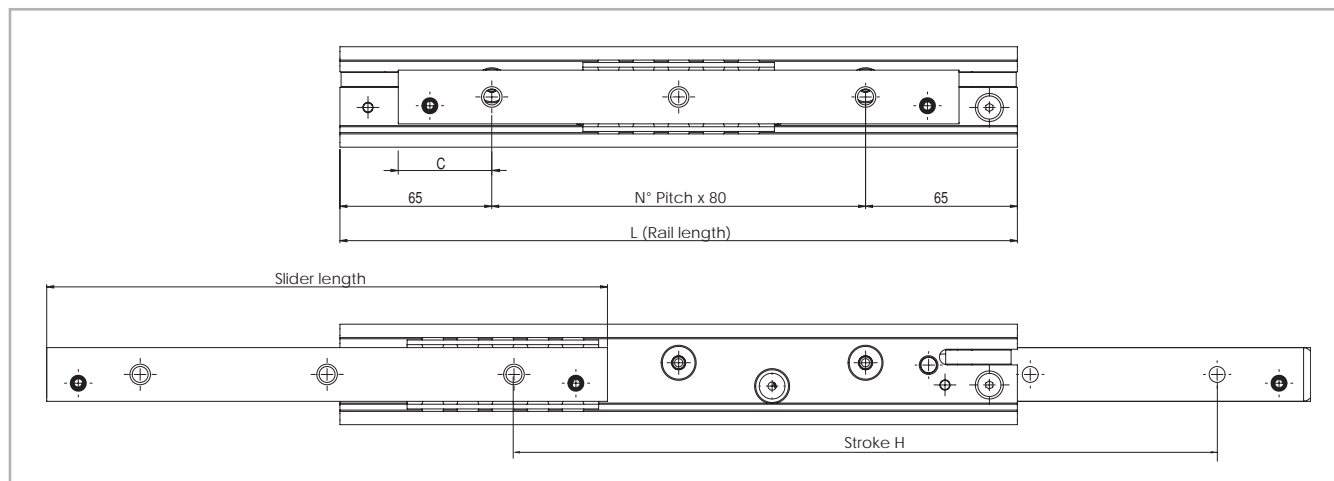

Fig. 52

D version (with a driving disc)

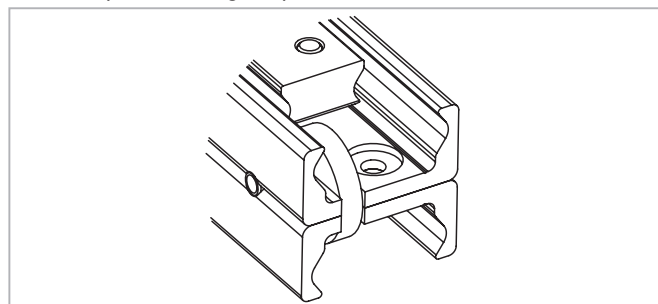

Fig. 53

The driving disc in the intermediate element in the DE...D versions acts to make sure that in bilateral strokes (double strokes) the intermediate element always returns to the correct position and does not remain in an undefined position. This design is available in sizes 28, 35, 43 and 63 with all three versions of the fixing holes. This version is based on the standard DE series version, but differs in the technical characteristics for the construction methods. Please contact our technical service department for more information.

Type	Size	Length L [mm]	Stroke H [mm]	Load capacity for a pair of rails		Slider [mm]	C [mm]	No. of holes
				C _{0rad} [N]	C _{0ax} [N]			
DEF...D DEV...D DEM...D	28	290	292	836*	586	250	45	3
		370	376	1224	856	330	45	4
		450	460	1618	782	410	45	5
		530	544	2014	658	490	45	6
		610	628	1940	570	570	45	7
		690	712	1706	500	650	45	8
		770	796	1524	448	730	45	9
		850	880	1376	404	810	45	10
		930	964	1256	368	890	45	11
		1010	1048	1154	338	970	45	12
		1090	1132	1068	314	1050	45	13
1170	1216	992	292	1130	45	14		

*Reduce the load capacity by 25% for counter-sunk (DEV) and mixed (DEM) hole versions. Tab. 35

Type	Size	Length L [mm]	Stroke H [mm]	Load capacity for a pair of rails		Slider [mm]	C [mm]	No. of holes
				C _{0rad} [N]	C _{0ax} [N]			
DEF...D DEV...D DEM...D	35	290	303	890	624	250	45	3
		370	391	1322	926	330	45	4
		450	479	1760	1232	410	45	5
		530	543	2562	1534	490	45	6
		610	631	3012	1308	570	45	7
		690	719	3460	1140	650	45	8
		770	783	3302	1072	730	45	9
		850	871	2946	956	810	45	10
		930	959	2660	864	890	45	11
		1010	1023	2536	824	970	45	12
		1090	1111	2322	754	1050	45	13
		1170	1199	2140	694	1130	45	14
		1250	1263	2060	668	1210	45	15
		1330	1351	1916	622	1290	45	16
		1410	1439	1790	582	1370	45	17
		1490	1503	1734	562	1450	45	18

Tab. 36

Type	Size	Length L [mm]	Stroke H [mm]	Load capacity for a pair of rails		Slider [mm]	C [mm]	No. of holes
				C _{0rad} [N]	C _{0ax} [N]			
DEF...D DEV...D DEM...D	43	290	301	1002*	702	240	40	3
		370	401	1400	980	320	40	4
		450	471	2318	1622	400	40	5
		530	541	3312	2318	480	40	6
		610	641	3696	2484	560	40	7
		690	711	4724	2280	640	40	8
		770	781	5784*	2108	720	40	9
		850	881	5506	1830	800	40	10
		930	951	5166	1718	880	40	11
		1010	1021	4866	1618	960	40	12
		1090	1121	4360	1450	1040	40	13
		1170	1191	4144	1378	1120	40	14
		1250	1261	3948	1312	1200	40	15
		1330	1361	3608	1200	1280	40	16
		1410	1431	3458	1150	1360	40	17
		1490	1501	3322	1104	1440	40	18
		1570	1601	3076	1024	1520	40	19
		1650	1671	2968	986	1600	40	20
		1730	1741	2866	952	1680	40	21
		1810	1841	2682	892	1760	40	22
1890	1911	2600	864	1840	40	23		
1970	2011	2448	814	1920	40	24		

*Reduce the load capacity by 25% for counter-sunk (DEV) and mixed (DEM) hole versions. Tab. 37

Type	Size	Length L [mm]	Stroke H [mm]	Load capacity for a pair of rails		Slider [mm]	C [mm]	No. of holes
				C _{0rad} [N]	C _{0ax} [N]			
DEF...D	63	610	602	7688	5382	558	39	7
		690	682	9236	6466	638	39	8
		770	762	10796	6514	718	39	9
		850	842	12362	5890	798	39	10
		930	922	13934	5374	878	39	11
		1010	1002	15512	4942	958	39	12
		1090	1082	14386	4574	1038	39	13
		1170	1162	13388	4256	1118	39	14
		1250	1242	12520	3980	1198	39	15
		1330	1322	11758	3738	1278	39	16
		1410	1402	11084	3524	1358	39	17
		1490	1482	10482	3332	1438	39	18
		1570	1562	9942	3160	1518	39	19
		1650	1642	9456	3006	1598	39	20
		1730	1722	9014	2866	1678	39	21
		1810	1802	8612	2738	1758	39	22
		1890	1882	8244	2620	1838	39	23
		1970	1962	7906	2514	1918	39	24

Tab. 38

> DED version D

DED with double direction stroke (double stroke)

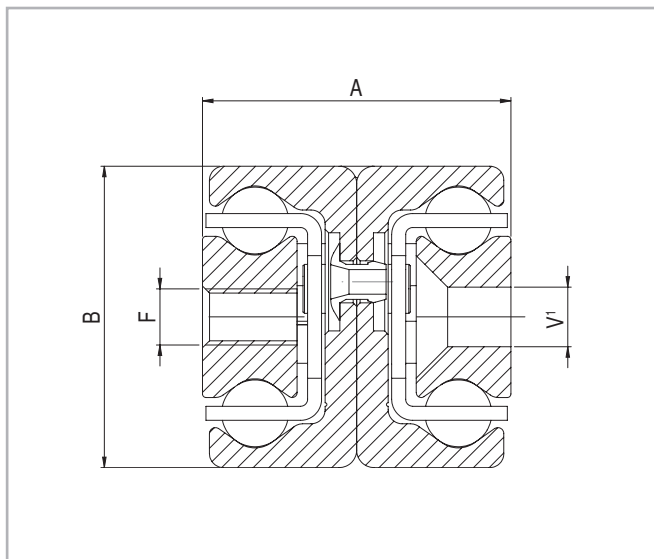

¹ Fixing holes (V) for countersunk head screws according to DIN 7991

Fig. 54

Type	Size	Cross-section				Weight per single guide [kg/m]
		A [mm]	B [mm]	F	V ¹	
DE...D	28	26	28	M5	M5	4.04
	35	34	35	M6	M6	6.10
	43	44	43	M8	M8	10.50
	63	58	63	M8	-	20.60

Tab. 39

There are three options for mounting holes available for the DE...D series in sizes 28 to 43:

Version DEF with threaded holes,

Version DEV with counter-sunk holes,

Version DEM, both variants (mixed).

Size 63 is only available with threaded holes.

> DE...Z

Version Z with synchronized full extension

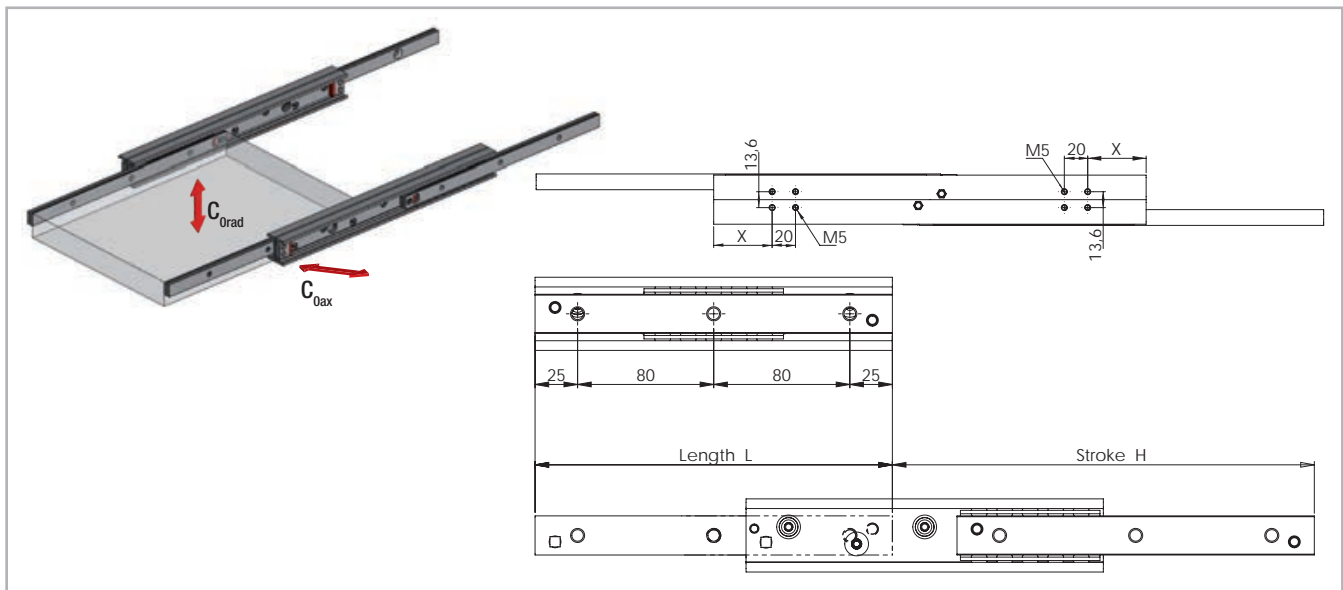

Fig. 55

Type ¹	Size	Length L [mm]	Stroke H [mm]	X	Load capacity for a pair of rails		No. of holes
					C _{Orad} [N]	C _{Oax} [N]	
DEF...Z	43	290	243	30	1746	1222	4
		370	323	50	1947	1363	5
		450	403	70	2481	1737	6
		530	483	90	3016	1915	7
		610	563	110	3229	1618	8
		690	643	130	3762	1401	9
		770	723	150	3714	1235	10
		850	803	170	3321	1104	11
		930	883	190	3004	999	12
		1010	963	210	2741	911	13
		1090	1043	230	2521	838	14
		1170	1123	250	2334	776	15
		1250	1203	270	2172	722	16
		1330	1283	290	2032	675	17
		1410	1363	310	1908	634	18
		1490	1443	330	1799	598	19
		1570	1523	350	1701	566	20
		1650	1603	370	1614	537	21
		1730	1683	390	1535	510	22
		1810	1763	410	1463	486	23
1890	1843	430	1398	465	24		
1970	1923	450	1338	445	25		

Z version (with rack and pinion)

The rack and pinion system allows the rail to open starting from the intermediate element, thus permitting a synchronized full extension and guaranteeing a multiplication of the drive (for equal lengths in rail stroke, the drive stroke is cut in half). This version is based on the standard DE series version, but differs in the technical characteristics for the construction methods. Please contact our technical service department for more information.

¹ The synchronized full extension is only available in version F with threaded mounting holes

Tab. 40

> DE...Z

DE...Z Version Z with synchronized full extension

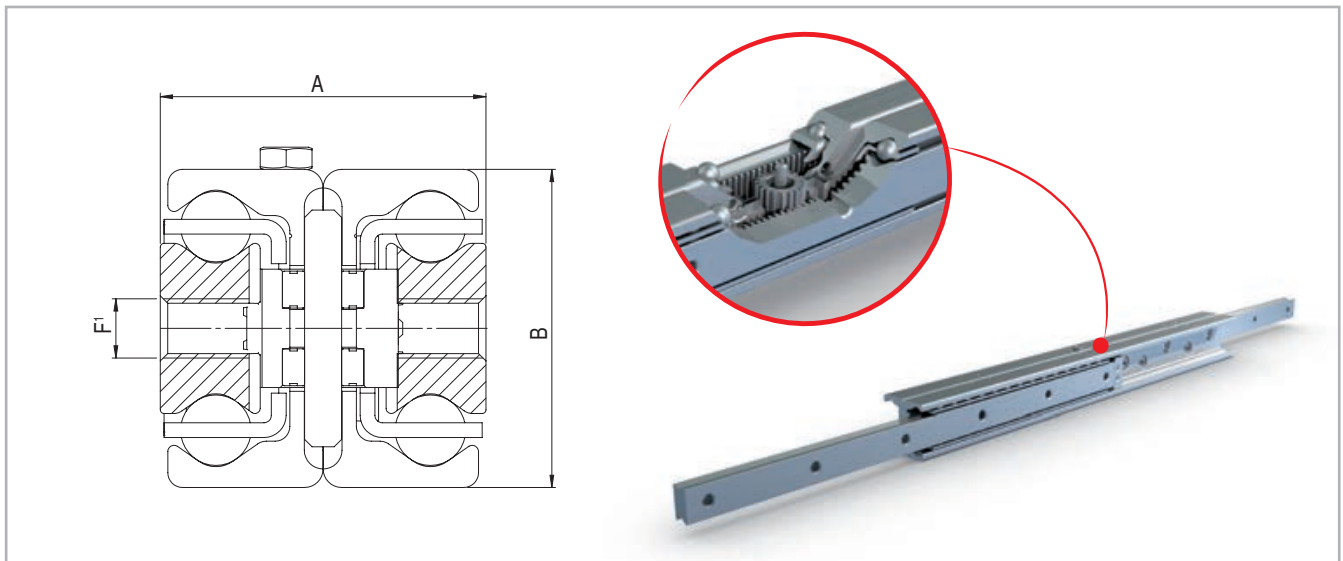

¹ Fixing holes (V) for countersunk head screws according to DIN 7991
^{*} Max fixing screw length 10mm

Fig. 56

Type	Size	Cross-section			Weight per single guide [kg/m]
		A [mm]	B [mm]	F	
DEF...Z	43	44	43	M8	10.50

Tab. 41

DEF43Z with threaded holes is available in left and right version:

DEF43Z...L

DEF43Z...R

> DBN

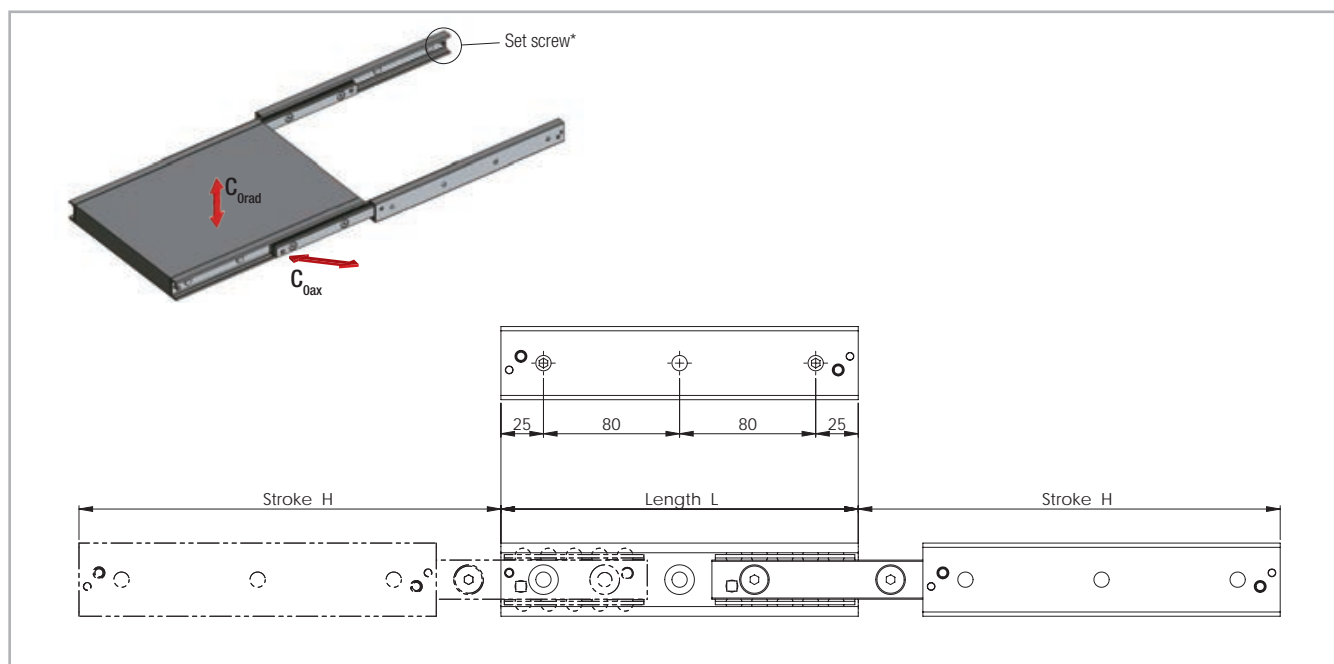

* Remove the set screw to reach all the fixing holes. See also assembly instructions on page TR-45f.

Fig. 57

Type	Size	Length L [mm]	Stroke H [mm]	Load capacity for a pair of rails		No. of holes
				C _{Orad} [N]	C _{Oax} [N]	
DBN	22	130	152	238	166	2
		210	222	562	392	3
		290	308	472	472	4
		370	392	372	372	5
		450	462	324	324	6
		530	548	272	272	7
		610	632	234	234	8
		690	702	216	216	9
		770	788	190	190	10

Tab. 42

Type	Size	Length L [mm]	Stroke H [mm]	Load capacity for a pair of rails		No. of holes
				C _{Orad} [N]	C _{Oax} [N]	
DBN	28	130	148	470	328	2
		210	232	864	604	3
		290	296	1244	1074	4
		370	380	964	964	5
		450	464	786	786	6
		530	548	664	664	7
		610	633	572	572	8
		690	717	504	504	9
		770	801	452	452	10
		850	866	426	426	11
		930	950	388	388	12
		1010	1034	356	356	13
		1090	1118	328	328	14
		1170	1202	304	304	15

Tab. 43

Type	Size	Length L [mm]	Stroke H [mm]	Load capacity for a pair of rails		No. of holes
				C _{Orad} [N]	C _{Oax} [N]	
DBN	35	210	254	804	562	3
		290	318	1334	1120	4
		370	406	1044	1044	5
		450	494	858	858	6
		530	558	788	788	7
		610	646	676	676	8
		690	734	594	594	9
		770	798	558	558	10
		850	886	500	500	11
		930	974	454	454	12
		1010	1038	434	434	13
		1090	1126	398	398	14
		1170	1214	366	366	15
		1250	1278	354	354	16
		1330	1366	330	330	17
		1410	1454	308	308	18
		1490	1518	298	298	19

Tab. 44

Type	Size	Length L [mm]	Stroke H [mm]	Load capacity for a pair of rails		No. of holes
				C _{Orad} [N]	C _{Oax} [N]	
DBN	43	210	246	1210	848	3
		290	316	2228	1560	4
		370	416	2600	1820	5
		450	486	2662	2558	6
		530	556	2386	2386	7
		610	626	2164	2164	8
		690	726	1824	1824	9
		770	796	1690	1690	10
		850	866	1576	1576	11
		930	966	1386	1386	12
		1010	1036	1308	1308	13
		1090	1106	1238	1238	14
		1170	1206	1118	1118	15
		1250	1276	1066	1066	16
		1330	1376	976	976	17
		1410	1446	938	938	18
		1490	1516	900	900	19
		1570	1586	868	868	20
		1650	1686	806	806	21
		1730	1756	780	780	22
		1810	1856	730	730	23
		1890	1926	708	708	24
		1970	2026	668	668	25

Tab. 45

> DBN

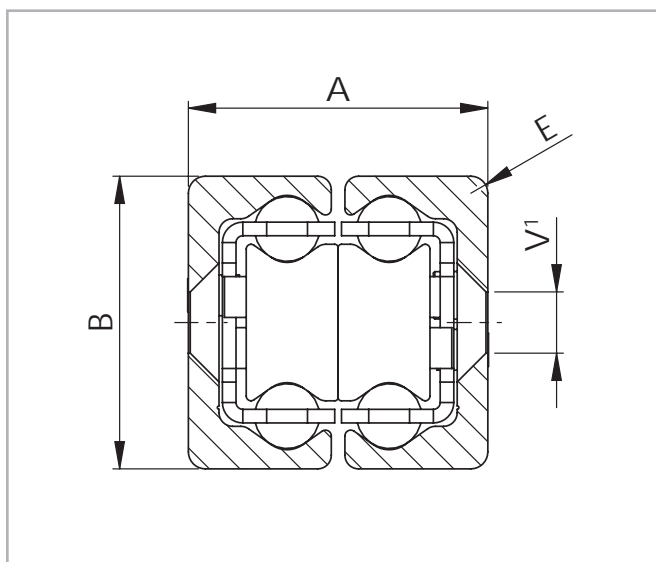

¹ Fixing holes (V) for countersunk head screws according to DIN 7991

Fig. 58

Type	Size	Cross-section				Weight per single guide [kg/m]
		A [mm]	B [mm]	E [mm]	V	
DBN	22	22	22	3	M4	2.64
	28	26	28	1	M5	4.04
	35	34	35	2	M6	6.10
	43	44	43	2.5	M8	10.50

Tab. 46

Please note the technical information "Double-sided stroke" on page TR-42

> DMS

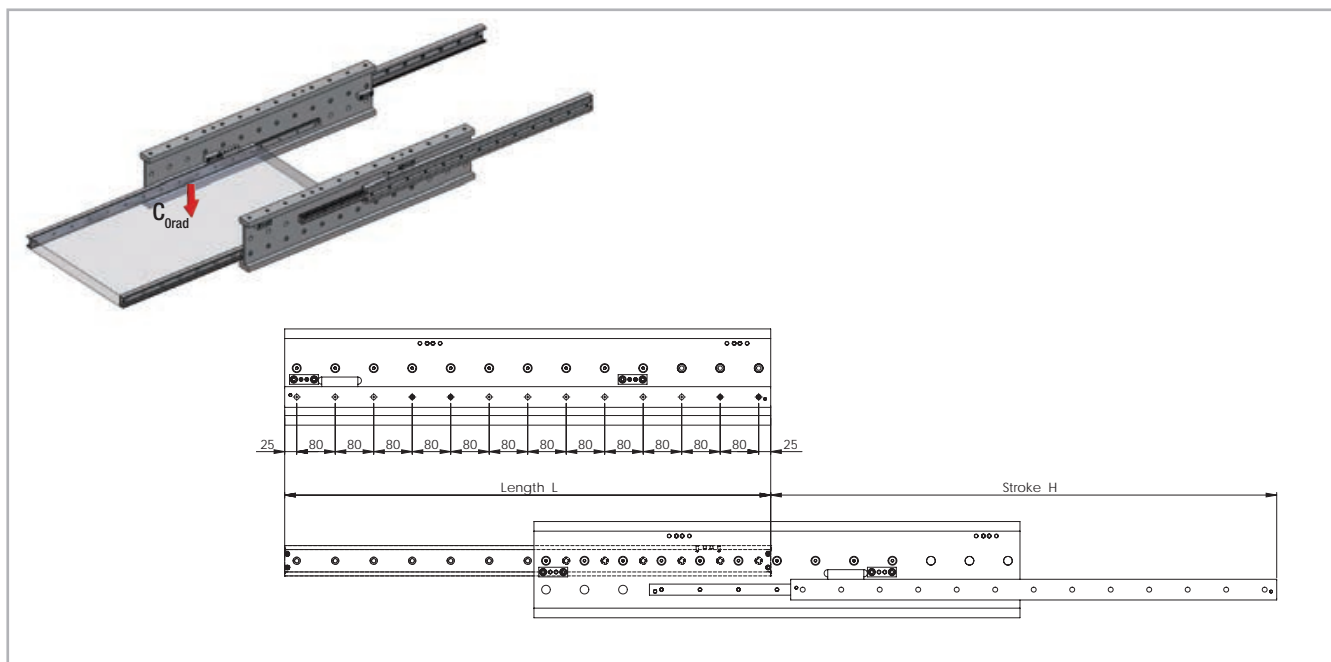
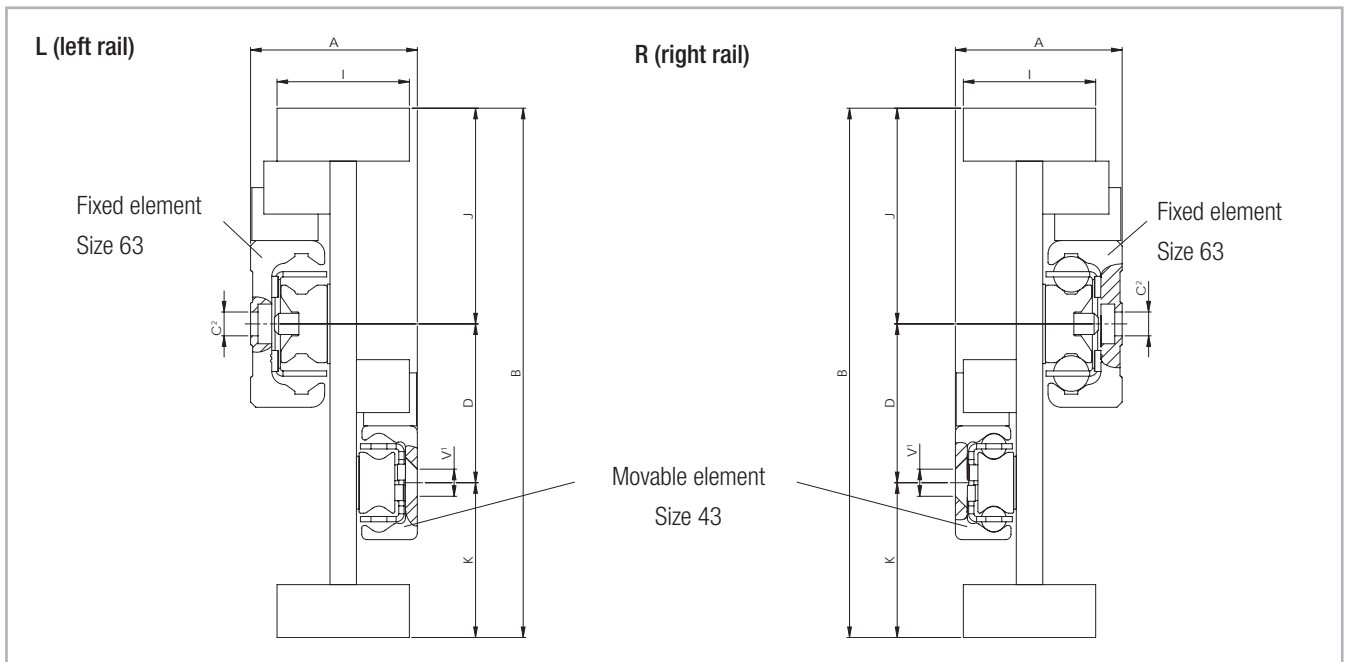

Fig. 59

Type	Size	Length L [mm]	Stroke H [mm]	Load capacity for a pair of rails C_{Orad} [N]	Fixed element Accessible holes / total	Movable element Accessible holes / total
DMS	63	1010	1051	16104	10 / 13	10 / 13
		1090	1141	17496	10 / 14	11 / 14
		1170	1216	19168	11 / 15	11 / 15
		1250	1291	20848	12 / 16	13 / 16
		1330	1381	22238	13 / 17	13 / 17
		1410	1456	23920	13 / 18	14 / 18
		1490	1531	25608	14 / 19	14 / 19
		1570	1621	26996	14 / 20	15 / 20
		1650	1696	28686	16 / 21	16 / 21
		1730	1771	30380	16 / 22	17 / 22
		1810	1861	31766	17 / 23	17 / 23
		1890	1936	33460	18 / 24	19 / 24
		1970	2026	34846	19 / 25	19 / 25
		2050	2101	36542	19 / 26	20 / 26
		2130	2176	38240	20 / 27	20 / 27
2210	2266	39624	21 / 28	22 / 28		

Tab. 47

> DMS



¹ Fixing holes (V) for countersunk head screws according to DIN 7991

² Fixing holes (C) for socket cap screws according to DIN 7984. Alternative fixing with Torx® screws in special design with low head (on request)
Please observe right or left installation for version DMS.

Fig. 60

Type	Size	Cross-section								Weight per single guide [kg/m]
		A [mm]	B [mm]	I [mm]	K [mm]	D [mm]	J [mm]	C	V	
DMS	63	63	200	50	58.5	60	81.5	M8	M8	43

Tab. 48

Technical instructions



> Telescopic rail selection

Selecting the suitable telescopic rail should be done based on the load and the maximum permissible deflection in the extended state. The load capacity of a telescopic rail depends on two factors: the loading capacity of the ballcage and the rigidity of the intermediate element. For mainly short strokes the load capacity is determined by the load-bearing capacity of the ballcage; for average and long strokes it is determined by the rigidity of the intermediate element. Therefore series, which otherwise contain comparable components, are also suited for differing load capacities.

> Static load check

The values in the load capacity tables of the corresponding series (see Sect. 4, Product Dimensions, pg. TR-8ff) give the maximum permissible loading of a pair of rails in the middle of the two rails and in the center line of the moving element with the rails in the completely extended state.

Using a pair of rails, the loading acts in the centre on both rails (see fig. 62, P).

The load capacity of a rail pair is:

$$C_{0rad}$$

Fig. 61

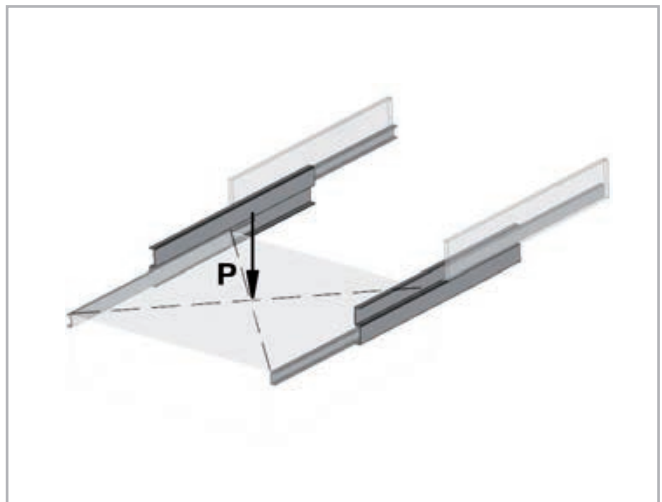

Fig. 62

> Deflection

If the load P acts vertically on the pair of rails (see fig. 65), the expected elastic deflection in the extended state can be determined as follows:

$$f = \frac{q}{t} \cdot P \quad (\text{mm})$$

Fig. 63

Whereby:

f is the expected elastic deflection in mm

q is a stroke coefficient (see fig. 66/67)

t is a factor depending on the model of the telescopic rail (see fig. 64)

P is the actual load acting on the centre of a pair of rails, in N

Also refer to page TR-38 for checking the static load

DS28	t = 360	DBN22	t = 6
DS35	t = 940	DBN28	t = 16
DS43	t = 1600	DBN35	t = 26
DS63	t = 8000	DBN43	t = 112
DE22	t = 16	DMS63	t = 7000
DE28	t = 34	DSC43	t = 1600
DE35	t = 108	DSE28	t = 20
DE43	t = 240	DSE35	t = 60
DE63	t = 1080	DSE43	t = 116
		DSE63	t = 556

Fig. 64

This estimated value assumes an absolutely rigid adjacent construction. If this rigidity is not present, the actual deflection will deviate from the calculation.

Important:

With the partial extensions of the ASN series, the deflection is almost completely determined by the rigidity, i.e. by the moment of inertia of the adjacent construction.

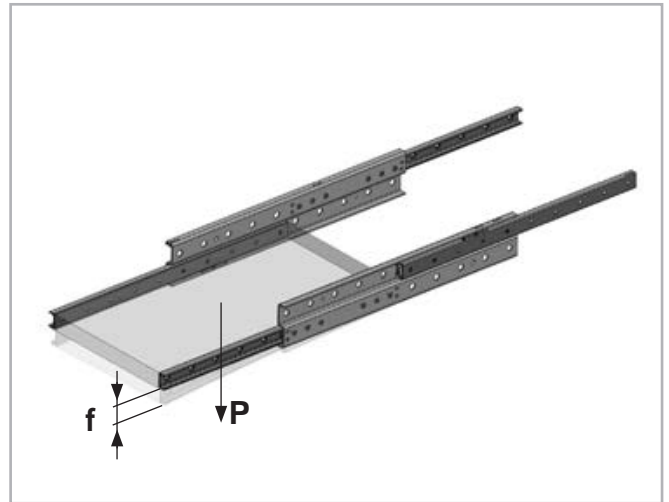

Fig. 65

For rails type DS, DE, DBN, DMS, DSC

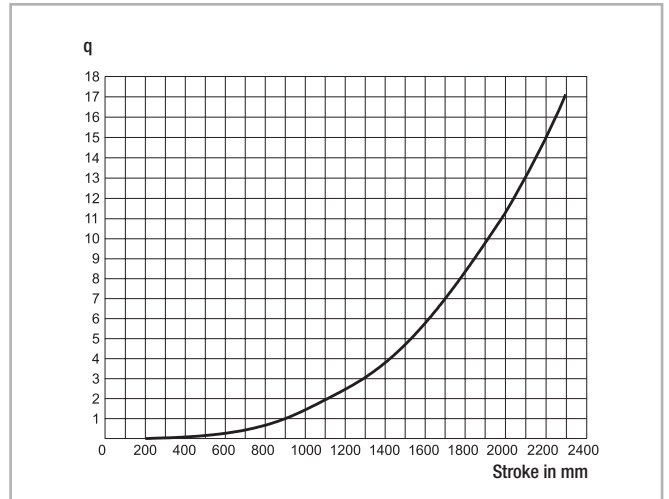

Fig. 66

For rail type DSE

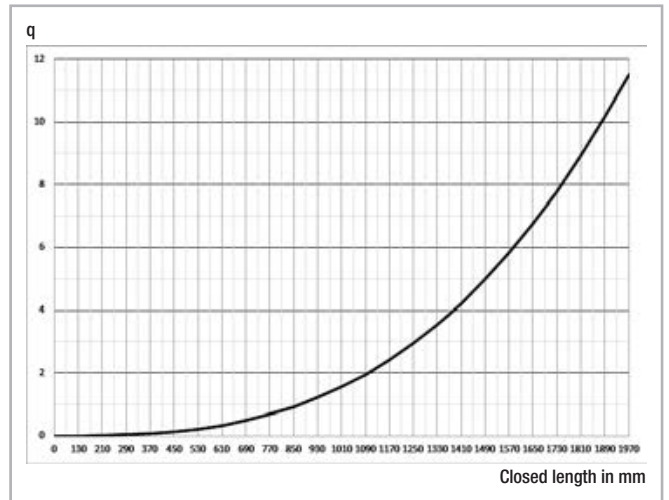

Fig. 67

> Static load

The telescopic extension of the various series allow different forces and moments (see Sect. 4, Product dimensions, pg. TR-8ff).

During the static tests the radial load capacity, C_{Orad} , the axial load capacity, C_{Oax} , and moments M_x , M_y and M_z indicate the maximum permissible values of the loads; higher loads negatively effect the running properties

and the mechanical strength. A safety factor, S_0 , is used to check the static load, which takes into account the basic parameters of the application and is defined in more detail in the following table:

Safety factor S_0

Neither shocks nor vibrations, smooth and low-frequency reverse, high assembly accuracy, no elastic deformations	1.5
Normal installation conditions	1.5 - 2
Shocks and vibrations, high-frequency reverse, significant elastic deformation	2 - 3.5

Tab. 49

The ratio of the actual load to maximum permissible load may be as large as the reciprocal of the accepted safety factor, S_0 , at the most.

$\frac{P_{Orad}}{C_{Orad}} \leq \frac{1}{S_0}$	$\frac{P_{Oax}}{C_{Oax}} \leq \frac{1}{S_0}$	$\frac{M_1}{M_x} \leq \frac{1}{S_0}$	$\frac{M_2}{M_y} \leq \frac{1}{S_0}$	$\frac{M_3}{M_z} \leq \frac{1}{S_0}$
--	--	--------------------------------------	--------------------------------------	--------------------------------------

Fig. 68

The above formulas are valid for a single load case. If two or more of the described forces act simultaneously, the following check must be made:

$\frac{P_{Orad}}{C_{Orad}} + \frac{P_{Oax}}{C_{Oax}} + \frac{M_1}{M_x} + \frac{M_2}{M_y} + \frac{M_3}{M_z} \leq \frac{1}{S_0}$	<p>P_{Orad} = effective radial load C_{Orad} = permissible radial load P_{Oax} = effective axial load C_{Oax} = permissible axial load M_1 = effective moment in the x-direction M_x = permissible moment in the x-direction M_2 = effective moment in the y-direction M_y = permissible moment in the y-direction M_3 = effective moment in the z-direction M_z = permissible moment in the z-direction</p>
--	---

Fig. 69

> Service life

The service life is defined as the time span between commissioning and the first sign of fatigue or wear indications on the raceways. The service life of a telescopic rail is dependent on several factors, such as the effective load, the installation precision, occurring shocks and vibrations, the operating temperature, the ambient conditions and the lubrication. Calculation of the service life is based exclusively on the loaded rows of balls.

In practice, the decommissioning of the bearing, due to its destruction or extreme wear of a component, represents the end of service life. This is taken into account by an application coefficient (f_i in the formula below), so the service life consists of:

$$L_{km} = 100 \cdot \left(\frac{\delta}{W} \cdot \frac{1}{f_i} \right)^3$$

L_{km} = calculated service life in km
 δ = load capacity factor in N
 W = equivalent load in N for a pair of rails
 f_i = application coefficient

Fig. 70

Application coefficient f_i

	ASN, DS, DE, DBN, DSC
Neither shocks nor vibrations, smooth and low-frequency direction change, clean environment	1.3 - 1.8
Light vibrations and average direction change	1.8 - 2.3
Shocks and vibrations, high-frequency direction change, very dirty environment	2.3 - 3.5

Tab. 50

If the external load, P , is the same as the dynamic load capacity, C_{0rad} , (which of course must never be exceeded), the service life at ideal operating conditions ($f_i = 1$) amounts to 100 km.

Naturally, for a single load P , the following applies: $W = P$. If several external loads occur simultaneously, the equivalent load is calculated as follows:

$$W = P_{rad} + \left(\frac{P_{ax}}{C_{0ax}} + \frac{M_1}{M_x} + \frac{M_2}{M_y} + \frac{M_3}{M_z} \right) \cdot C_{0rad}$$

Fig. 71

Load capacity factor δ

Length [mm]	ASN					DS...				DSE				DSC
	22	28	35	43	63	28	35	43	63	28	35	43	63	43
	δ [N]					δ [N]								
130	830	1744												
210	1864	3154	3066	4576										
290	2590	5384	5812	8110		1726				1084				
370	3330	6810	7442	9588		2328				1466				
450	4410	8238	9074	13204		2932	3784			1848	2390			
530	5134	9664	11980	16902		3536	5080	6240		2232	3224	3976		7194
610	5872	11114	13606	20650	30006	4156	5756	7858	10656	2620	3650	5018	6690	8902
690	6960	12542	15234	22010	35416	4762	6434	8394	12918	3004	4080	4792	8126	9322
770	7684	13968	18186	25754	40854	5368	7762	10020	15208	3388	4934	6388	9578	11022
850		16222	19806	29524	46310	6360	8436	11672	17518	4028	5358	7452	11046	12746
930		17622	21428	30858	51778	6948	9110	12180	19842	4406	5784	7758	12526	13144
1010		19048	24402	34620	57258	7556	10452	13832	22178	4792	6650	8820	14012	15760
1090		20474	26018	35962	62748	8162	11122	15500	24522	5412	7072	9896	15504	16592
1170		21900	27636	39720	68242	8768	11794	15292	26874	5562	7496	10190	17002	17868
1250			30622	43494	73742	9792	13146	17658	29232		8368	11264	18504	18702
1330			32236	44822	79246	10386	13814	18154	31596		8790	11562	20010	19980
1410			33850	48590	84754	10992	14484	19818	33962		9212	12632	15914	20818
1490			36846	52372	90266	11612	15840	21492	36332		10088	13710	23028	23456
1570				56166	95780		16506	21976	38706			14096	24540	23826
1650				57466	101296		17176	23650	41080			15078	26056	24660
1730				61252	106814		18536	25330	43458			16160	27572	26394
1810				62562	112332			25808	45838			16444	29088	27824
1890				66344	117854			27486	48218			17526	30606	29408
1970				67658	123376			27966	50602			17814	32126	29770

Tab. 51

Length [mm]	DMS	DE... / DBN				DE	DE...S			DE...D			
	63	22	28	35	43	63	28	35	43	28	35	43	63
	δ [N]	δ [N]					δ [N]			δ [N]			
130		330	714										
210		772	1310	1228	1846								
290		1074	2306	2422	3374		1762			1274	1362	1538	
370		1380	2912	3104	3948		1650	2174	3064	1860	2018	2150	
450		1850	3518	3784	5528		2236	2720	2856	2454	2682	3534	
530		2150	4126	5080	7160		3176	3754	5186	3052	3884	5030	
610		2458	4744	5756	8828	12406	3424	4296	5768	3652	4564	5620	11652
690		2934	5350	6434	9322	14722	4384	5356	7328	4254	5244	7162	13978
770		3232	5958	7762	10986	17054	4624	5892	7896	4856	6516	8748	16322
850			6974	8436	12670	19398	5982	6966	10496	5460	7196	9304	18676
930			7566	9110	13144	21750	6198	7498	10038	6064	7966	10904	21038
1010	24308		8172	10452	14822	24110	7194	9160	12728	6668	9180	12530	23406
1090	29974		8776	11122	16514	26476	7800	9108	13250	7272	9858	13062	25778
1170	28914		9382	11794	16978	28846	8400	10782	14890	7878	10536	14692	28014
1250	32972			13146	18664	31220		11298	15410		11858	16338	30452
1330	33526			13814	19136	33596		12406	18216		11858	16852	32914
1410	39684			14484	20818	35974		12920	17570		13208	18500	35298
1490	38570			15840	22510	38356		14028	29374		14542	20160	37684
1570	44316				24210	40738			20868			20660	40070
1650	43196				24660	43122			22552			22320	42458
1730	49414				26356	45508			23028			23990	44846
1810	47822				26812	47896			25894			24480	47236
1890	51926				28504	50284			25188			26184	49626
1970	52450				28966	52672			24580			26640	52018
2050	58682												
2130	57526												
2210	61190												

Tab. 52

> Speed

The maximum operating speed is determined by the mass of the intermediate element, which moves with the movable rail. This reduces the maximum permissible operating speed with increasing length (see fig. 72).

Maximum acceleration: 1.2 m/s²

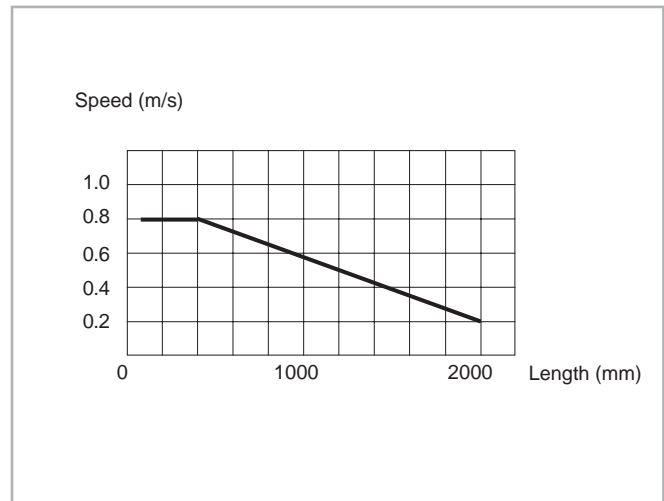

Fig. 72

> Opening and closing force

The required actuation forces of a telescopic rail depend on the acting load and the deflection in the extended state. The force required for opening is principally determined by the coefficient of friction of the linear bearing. With correct assembly and lubrication, this is 0.01. During the extension, the force is reduced with the elastic deflection of the loaded

telescopic rail. A higher force is required to close a telescopic extension, since, based on the elastic deflection, even if it is minimal, the movable rail must move against an inclined plane.

> Double-sided stroke

For all designs allowing double-sided stroke, it must be noted that the position of the intermediate element is defined only in the extended state. In the extended state, the intermediate element can protrude by half of its length on each side. Exception is the ASN series, which comes out as a partial extension without an intermediate element and the custom design of series DE with driving disc.

The double-sided stroke in the ASN, DE and DBN series is achieved by removing the set screw. For the DSD series, the double-sided stroke is implemented by design adaptation. Double-sided stroke for series DMS on request. The DSB series are not available with double-sided stroke.

> Temperature

- ASN, DE, DBN series can be used up to an ambient temperature of +170 °C (+338 °F). A lithium lubricant for high operating temperatures is recommended for temperatures above +130 °C (+266 °F). Minimum temperature with standard grease is -20 °C (-4 °F).
- The DS, DSE, DSC and DMS series have a useable range of -20 °C to +80 °C (-4 °F to +176 °F) due to of the rubber stop.
- The DSS43S and DE...S series have a temperature range of application from -20 °C to + 50 °C (-4 °F to 122 °F), due to the bumpers in special resin.

> Anticorrosive protection

Treatment	Characteristics
Zinc Plating ISO 2081	Standard treatment for rails it is ideal for indoor applications. Zinc-plated telescopic rails are supplied with steel balls
ZincNickel ISO19598 (Z)	Ideal for outdoor applications. Telescopic rails with this treatment are supplied with stainless steel balls to further increase the corrosion resistance.
Rollon E-coating (K)	Electro painting that provides a fine black finishing to the entire rail. It can be partially removed from the raceways on the running contact point of the balls after a period of use. Telescopic rails with Rollon E-Coating are supplied with stainless steel balls to further increase the corrosion resistance.
Nickel Plating (N)	Provides high resistance to chemical corrosion and is ideal for applications in medical or food related environments. Raceways are coated too. Telescopic rails with Nickel Plating are supplied with stainless steel balls to further increase the corrosion resistance.

Tab. 53

- Numerous application-specific surface treatments are available upon request, e.g., FDA approved nickel plating for use in the food industry. For more information please contact Rollon technical support. For specific information, contact Rollon technical support.

> Lubrication

Recommended lubrication intervals are heavily dependent upon the ambient conditions, speed and temperature. Under normal conditions, lubrication is recommended after 100 km operational performance or after an operating period of six months. In critical application cases the interval should be shorter. Please clean the raceways carefully before lubricating. Raceways and spaces of the ball cage are lubricated with a lithium lubricant of average consistency (roller bearing lubricant).

Different lubricants are available on request for special applications:

- FDA-approved lubricant for use in the food industry
- specific lubricant for clean rooms
- specific lubricant for the marine technology sector
- specific lubricant for high and low temperatures

For specific information, contact Rollon technical support.

> Clearance and preload

Telescopic Rail guides are mounted as standard with no play. For more information, please contact Rollon technical support.

Preload classes		
Increased clearance	No clearance	Increased preload
G ₁	Standard	K ₁

Tab. 54

* for higher preload, contact Rollon technical support.

> Fixing screws

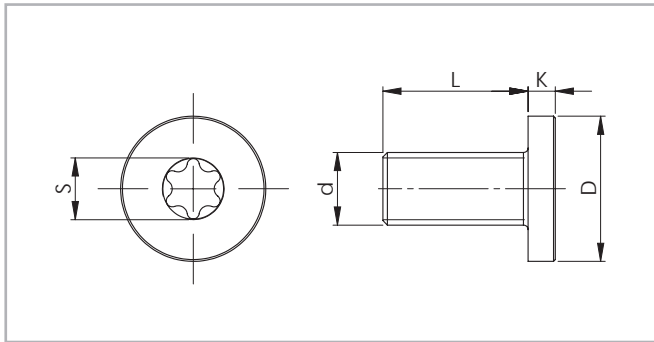

Fig. 73

All rails are fixed with counter-sunk or cap head screws as per DIN 7991 or 7984. In size 63 of the ASN and DMS series, Torx® screws with low head cap screws are available on request (see fig. 73).

Size	Screw type	d	D [mm]	L [mm]	K [mm]	S
63	M8 x 20	M8 x 1.25	13	20	5	T40

Tab. 55

Recommended Standard fixing screw tightening torques

Property class	Size	Tightening torque [Nm]
10.9	22	3
	28	6
	35	10
	43	25
	63	30

Tab. 56

Prepare a sufficient bevel on the threaded fixing holes, according to the following table:

Size	Bevel (mm)
22	0.5 x 45°
28	1 x 45°
35	1 x 45°
43	1 x 45°
63	1 x 45°

Tab. 57

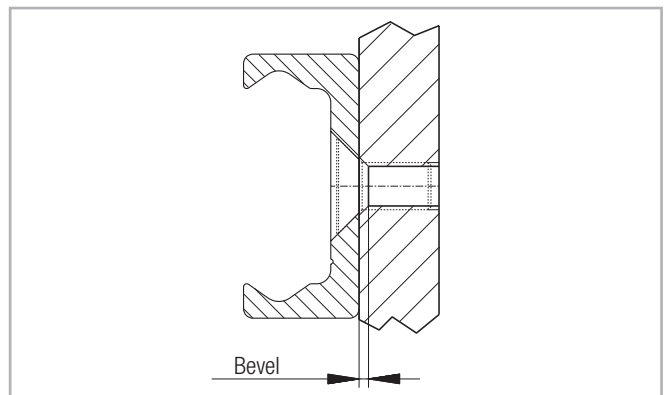
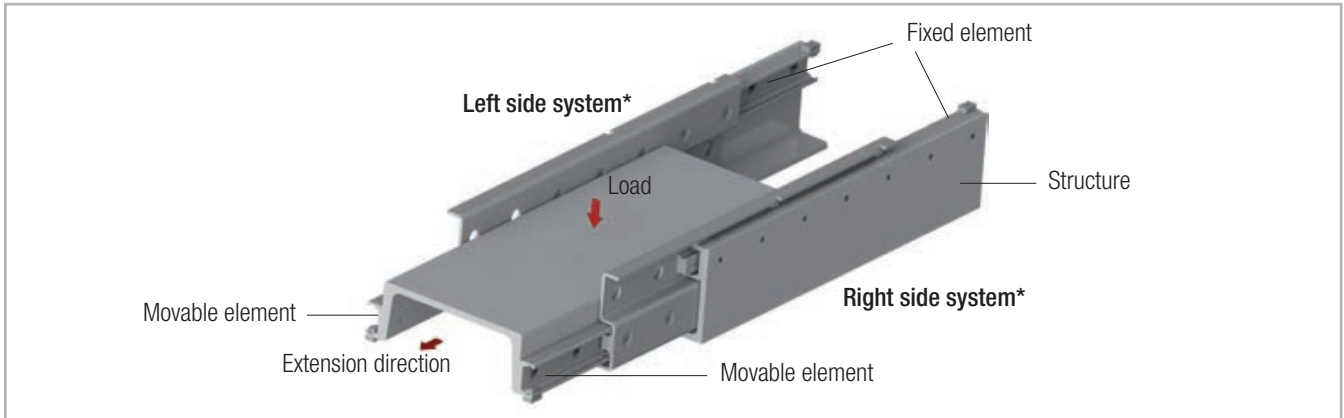

Fig. 74

> Installation instructions

In general and for ASN, DBN, DE, DMS, DSB, DSE



* For models DMS, DSB, and DSE, please observe right or left side use

Fig. 75

General

- Internal stops are used to stop the unloaded slider and the ball cage. Please use external stops as end stops for a loaded system.
- To achieve optimum running properties, high service life and rigidity, it is necessary to fix the telescopic rails with all accessible holes on a rigid and level surface.
- In order to reach all mounting holes for the ASN, DEV, DEM and DBN series it is necessary to remove the locking screw in the rail during assembly and then to reinsert it afterwards.
- Please observe the parallelism of the installation surfaces. The fixed and movable rails fit to the rigid assembly construction.
- Telescopic Rail guides are suitable for continuous use in automatic systems. For this, the stroke should remain constant in all moving cycles and the operating speed must be checked (see pg. TR-42, fig. 72). The movement of the telescopic rails is enabled by internal ballcages, which could experience an offset from the original position with differing strokes. This phase offset can have a negative effect on the running properties or limit the stroke. If differing strokes occur in an application, the drive force must be sufficiently dimensioned in order to appropriately synchronise the ballcage offset. Otherwise, an additional maximum stroke must be planned regularly to ensure the correct position of the ballcage.

ASN

- Series ASN accepts radial and axial loads and moments in all principle directions.
- The installation of two partial extensions on a profile provides a load capable full extension. For individual solutions, please contact Rollon technical support.

DE / DBN

- Series DE and DBN accept radial and axial loads.
- The functionality of custom design DE...D is only guaranteed if the stroke available is completely used.

DS / DSE / DMS

- Series DS, DES, DMS accept radial loads. This should act in the vertical cross-sectional axis on the movable rails.
- When installing make sure that the load is placed on the movable element (the lower rail) (see fig. 75). The opposite assembly negatively affects the function.
- Installation must be done on a rigid structure using all accessible fixing holes.
- Pay attention to the parallel alignment during assembly with paired application.

> Installation instructions

For DSC

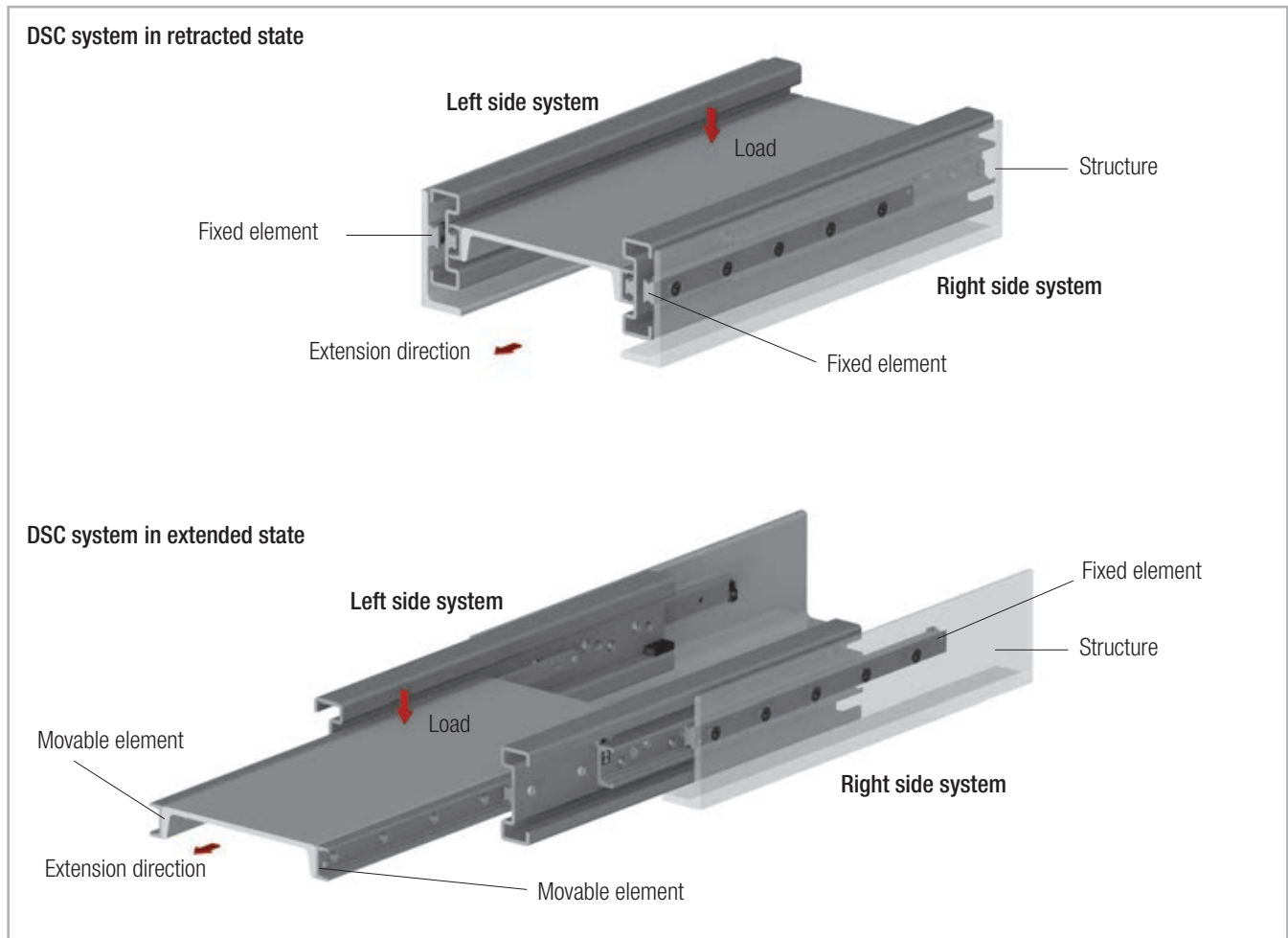

Fig. 76

DSC

- The DSC series absorbs radial and axial loads, in which case radial load directions are preferable.
- Horizontal and vertical use is possible. Prior to vertical installation we recommend inspection by the application engineers.
- During installation make sure that the load is mounted on the movable element (see Fig. 76). Reverse installation will impair proper functioning.
- The installation must be performed on a rigid structure, using all accessible mounting holes.
- Important: The length of the slider (fixed element) is different from the system length. See Table 23 on page TR-21 for DSC load ratings. The table also provides information on the accessible mounting holes.
- Important: The slide (fixed element) must be mounted in the front position when the system is retracted in order to achieve the entire stroke.
- Make sure the elements are aligned parallel during mounting.

Ordering key

> Telescopic rails

DSB	28	690	885	N	L	
						Right (R) or left (L) version (only for series DMS, DSB) <i>see pg. TR-7 Remarks</i>
						Expanded surface protection if deviation from standard (ISO 2081) <i>see pg. TR-43, Anticorrosive protection</i>
						Stroke, if deviating from standard stroke (catalogue data) <i>see pg. TR-8ff Product dimensions and Ordering key for special strokes</i>
						Length <i>see pg. TR-8ff Product dimensions</i>
						Size <i>see pg. TR-8ff Product dimensions</i>
						Product type <i>see pg. TR-8ff Product dimensions</i>

Ordering example 1: ASN35-0770

Ordering example 2: DSB28-0690-0885-L-N

Ordering example 3 (rail DE...D): DEF28D-0690

Notes on ordering: Information for right and left side installation and for expanded surface protection is only necessary if required.

Rail lengths and stroke lengths are always stated with 4 digits. Please pad with zeroes to fill in for lengths with less than 4 digits, e.g. 515mm length is "0515"

> Special strokes

Special strokes are defined as deviations from standard stroke H. They are each available as multiples of the values in tab. 58 and 59.

These values are dependent on the spacing of the ballage.

Type	Size	Stroke modification [mm]
ASN	22	7.5
	28	9.5
	35	12
	43	15
	63	20

Tab. 58

Stroke modification of series DMS on request.

No stroke modification is possible for the DSD and DSC series. Each stroke modification influences the load capacities stated in the catalogue. It is possible that after a stroke modification important fastening holes might no longer be accessible. For more information please contact Rollon technical support.

Type	Size	Stroke modification [mm]
DSS DE DBN	22	15
	28	19
	35	24
	43	30
	63	40
DE...S	28	19
	35	22
	43	30
DSE	28	28.5
	35	36
	43	45
	63	60

Tab. 59

ROLLON[®]
BY TIMKEN

Hegra Rail

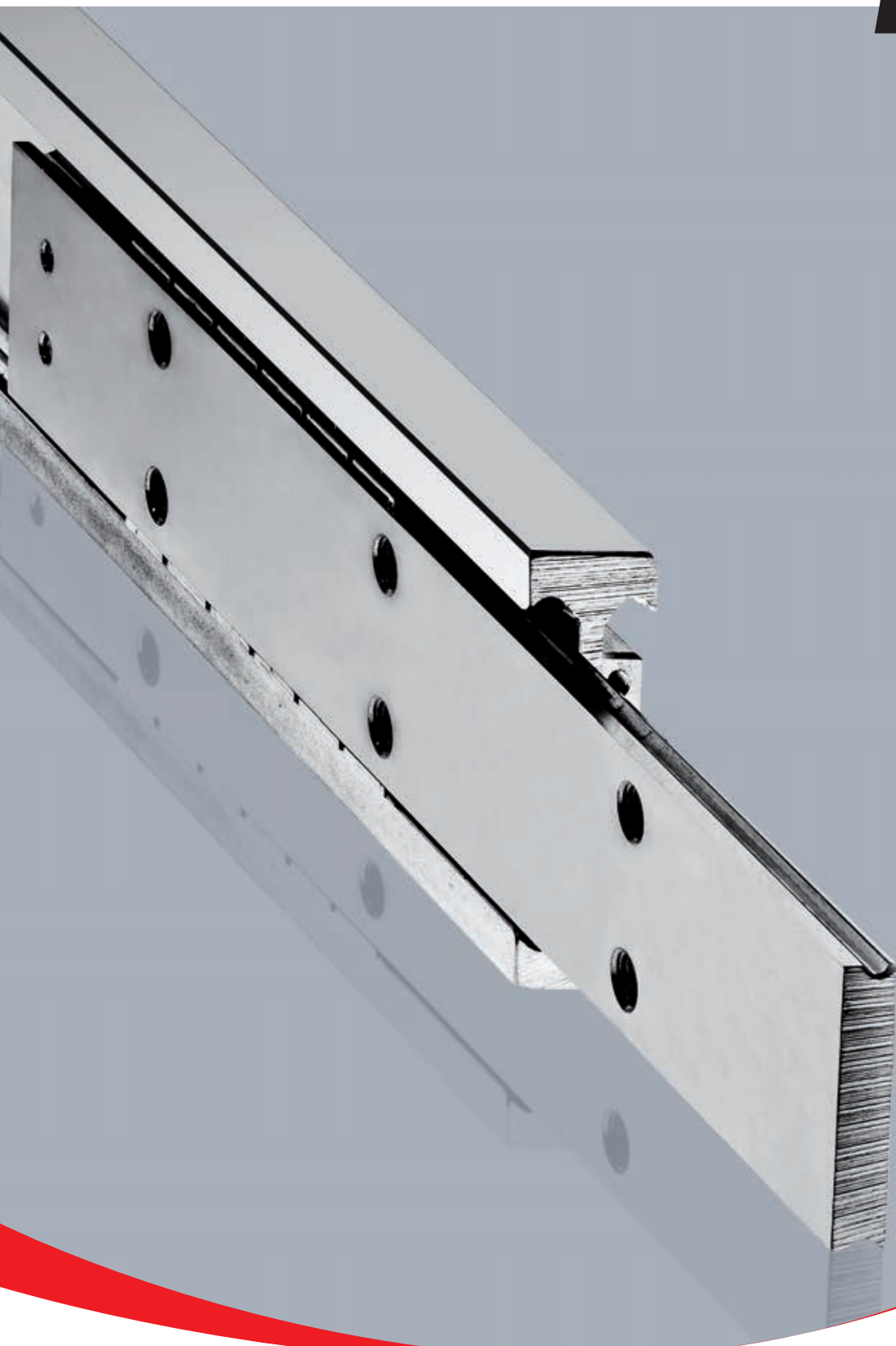

Product explanation



> Partial and full extension guides of different types



Fig. 1

The Hegra Rail product family consists of five product categories: partial, fully extending, overextending and heavy-duty rails as well as S-profiles. Different versions in the single categories, such as design or materials, also provide for increased customer benefits.

The most important characteristics:

- High load capacity and minimal deflection
- Different versions and materials
- Compact design
- Lightweight; smooth operation
- Long life
- High functional reliability

Preferred applications:

- Rail vehicles (maintenance and battery compartments)
- Motor vehicle technology
- Construction and machine technology
- Special purpose machinery

Partial extension guides

Partial extension guides with a stroke of more than 50 % of the closed telescoping length, consisting of one guide rail and one slider. The high system rigidity is achieved here in combination with the connection construction.



Fig. 2

Full extension guides

Full extension guides with strokes of about 100 % of the closed length consisting of three elements in different designs and sizes.



Fig. 3

Overextending guides

Overextending guides with a stroke of up to 200 % of the closed telescoping length. The use of intermediate elements with a high moment of inertia achieves excellent system rigidity and a high load capacity in fully extended systems.



Fig. 4

Heavy load extension guides

Full extension guides with strokes of about 100 % of the length consist of a solid, double T-shaped intermediate element and the two corresponding sliders. This full extension guide was specially designed for extremely heavy loads with minimal deflection and high system rigidity.



Fig. 5

S-profiles

Full extension guides with strokes of about 100 % of the closed length consisting of two guide rails and one S-shaped intermediate element. The advantages of the full extension guide are high rigidity and a compact design.



Fig. 6

Overview product cross sections



> Partial extension guides

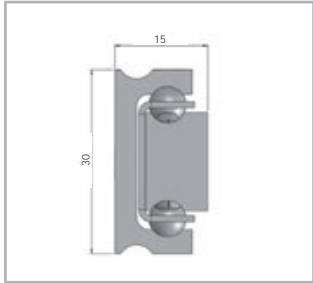

Fig. 7

HTT030

Load capacities p. HR-7

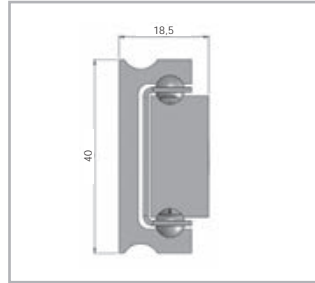

Fig. 8

HTT040

Load capacities p. HR-8

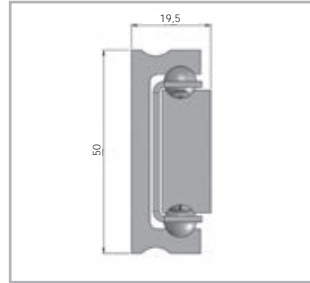

Fig. 9

HTT050

Load capacities p. HR-9

> Full extension guides

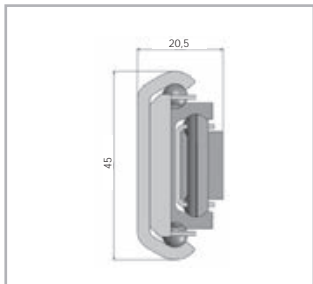

Fig. 10

HVC045

Load capacities p. HR-11

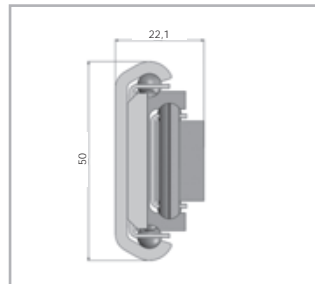

Fig. 11

HVC050

Load capacities p. HR-12

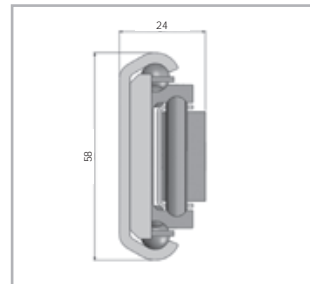

Fig. 12

HVC058

Load capacities p. HR-13

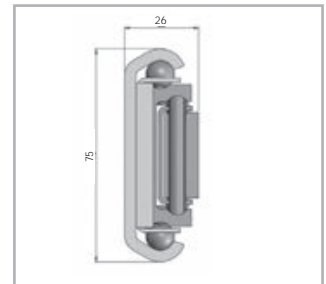

Fig. 13

HVC075

Load capacities p. HR-14

> Overextending guides

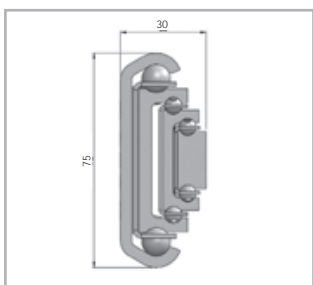

Fig. 14

H1C075

Load capacities p. HR-16

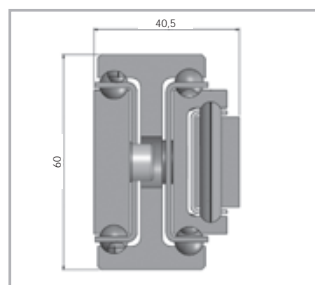

Fig. 15

H1T060

Load capacities p. HR-18

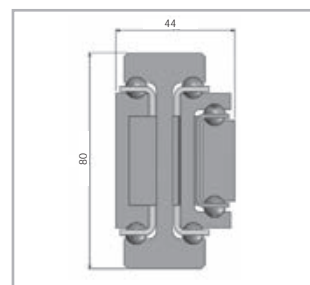

Fig. 16

H1T080

Load capacities p. HR-19

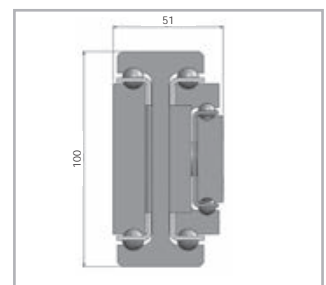

Fig. 17

H1T100

Load capacities p. HR-20

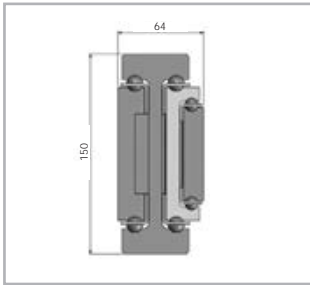

Fig. 18

H1T150

Versions are available on request
Load capacities p. HR-21

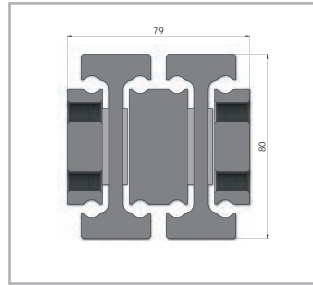

Fig. 19

H2H080

Load capacities p. HR-22

> **Heavy load extension guides**

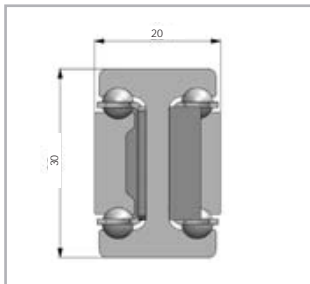

Fig. 20

LTH30

Load capacities p. HR-24

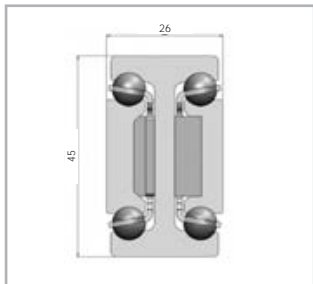

Fig. 21

LTH45

Load capacities p. HR-27

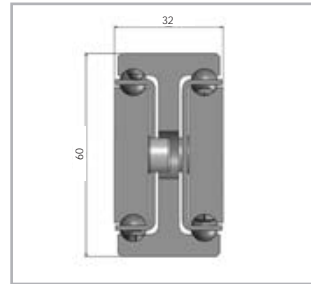

Fig. 22

HGT060

Load capacities p. HR-31

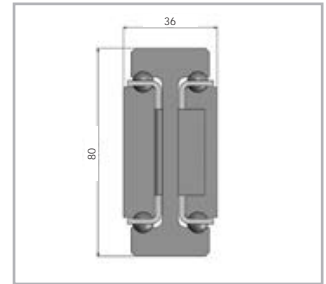

Fig. 23

HGT080

Load capacities p. HR-32

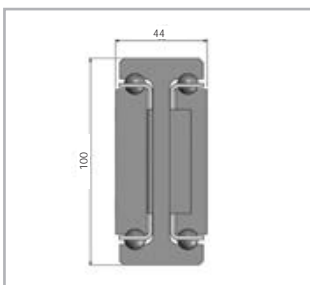

Fig. 24

HGT100

Load capacities p. HR-33

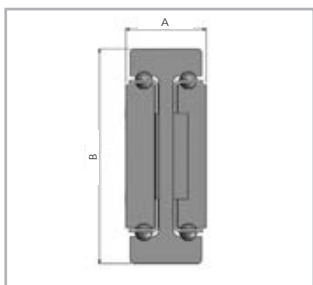

Fig. 25

HGT120, HGT150, HGT200, HGT240

Versions are available on request
Load capacities p. HR-33

HGT120: A = 44, B = 120
HGT 150: A = 56, B = 150
HGT 200: A = 72, B = 200
HGT 240: A = 74, B = 240

> **S-profiles**

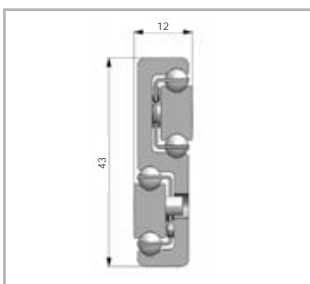

Fig. 26

LTF44

Load capacities p. HR-35

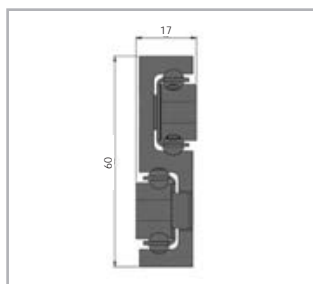

Fig. 27

HGS060

Load capacities p. HR-37

Technical data

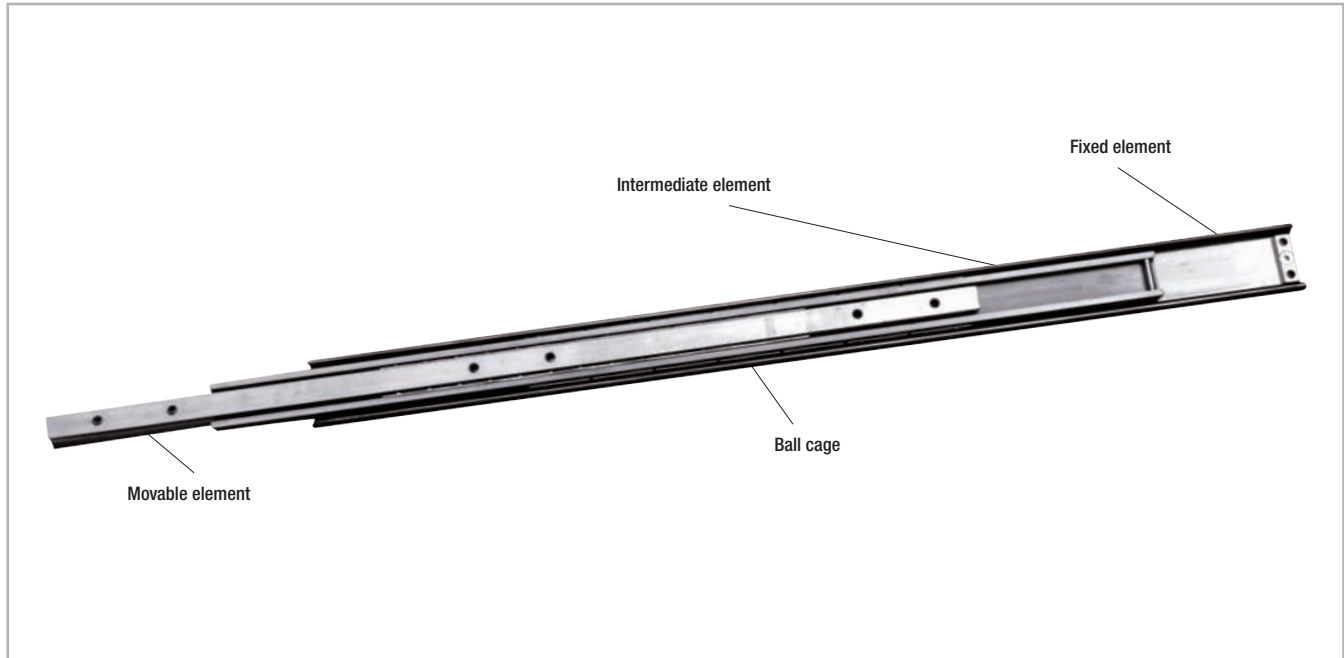

Fig. 28

Performance characteristics:

- Temperature range: -20 °C to +170 °C (-4 °F to +338 °F)
(in exceptions also -30 °C to +250 °C (-22 °F to +482 °F)
Above 80°C all rubber part, if they exist, must be removed.
- Max. operating speed 0.8 m/s (depending on the application)
- Different materials and anti-corrosion coatings are available
- Special solutions, such as locking mechanisms, catches, damping elements or are available on request

Attention!

The load capacity for aluminum is 40 % and for stainless steel 60 % of the stated values, if available in this material variant.

Notes:

- Horizontal movement installation is recommended
- Vertical movement installation on request
- Special strokes on request
- All load capacities refer to one telescopic pair
- Mounting screws with a strength class of 10.9 must be used for all telescopic rails
- Internal stops are provided to stop the sliders when not under load and the ball cage. Please use external stops as limit stops for a system under load
- Not all accessories (interlocks, damping, drive disk, snap) can be combined with each other. Please contact our technical service.
- For models HGT with locking please observe right or left side use.
- Temperature range: LTH
-20 °C to +170 °C (-4 °F to +338 °F)
- Temperature range: LTH ...S
-20 °C to +50 °C (-4 °F to +122 °F)
- Telescopic guides made of aluminum or stainless steel are standard without greasing. If a greasing is desired, it must be stated separately at the order.
- Please note eventually dimensional variations in use of stainless steel. Please contact our technical service.

Load capacities and dimensions

> HTT030

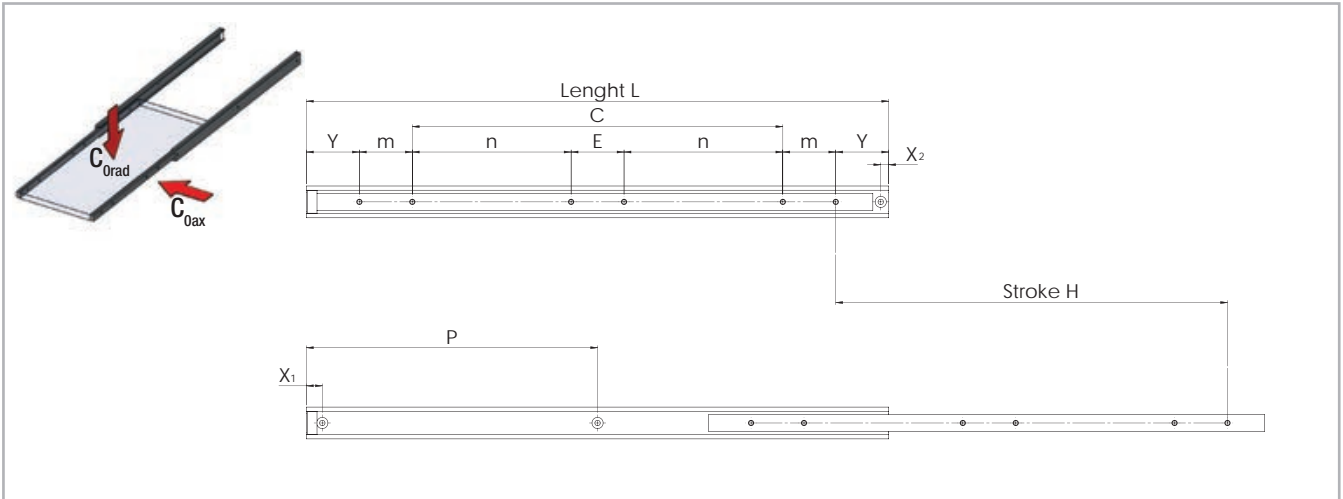

All dimensions are indicated in mm

Fig. 29

Type	Size	Length L [mm]	Stroke H [mm]	Load capacity per pair		X1*	X2	Y	m	n	E	C	P	Number of holes
				C _{Orad} [N]	C _{Oax} [N]									
HTT	30	250	130	1100	on request	15	7.5	50	50	-	-	50	125	4
		300	180	1200								100	150	
		350	230	1150								150	175	
		400	260	1100								200	200	
		450	310	1050								250	225	
		500	340	1000								300	250	
		550	370	950								150	275	6
		600	400	900								175	300	
		650	430	850								200	325	
		700	460	800								225	350	
		750	490	750								250	375	
		800	520	700								275	400	
		850	550	650								300	425	
		900	600	600								325	450	
		950	630	550								350	475	
		1000	660	500								375	500	

The load capacity for aluminum is 40% and for stainless steel 60% of the stated values, if available in this material variant (see Technical features overview).

* For double-sided stroke the dimension X1=7,5mm

Tab. 1

> **HTT040**

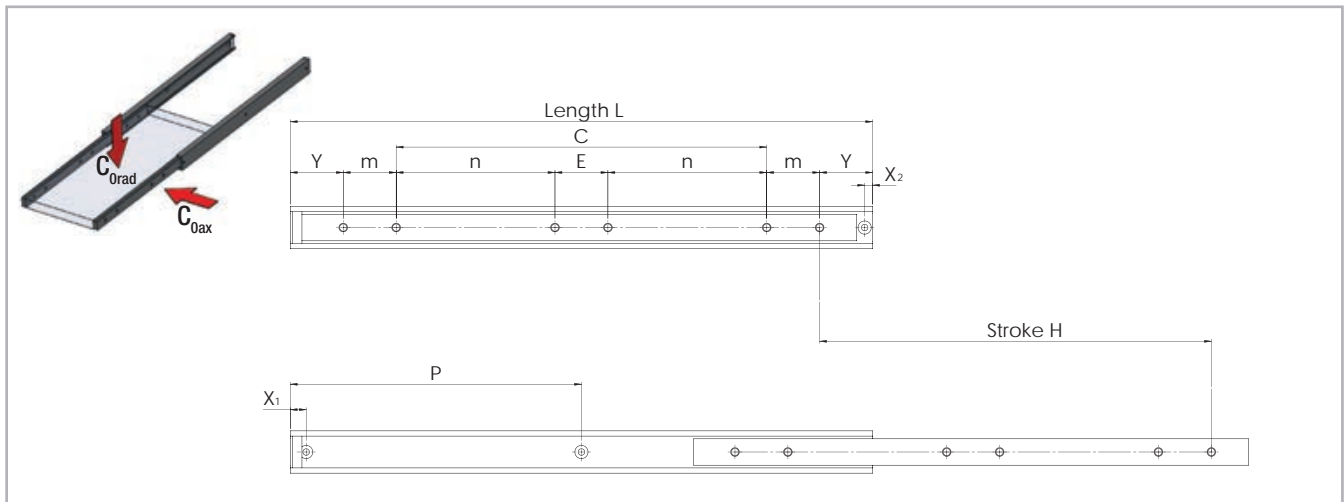

All dimensions are indicated in mm

Fig. 30

Type	Size	Length L [mm]	Stroke H [mm]	Load capacity per pair		X1*	X2	Y	m	n	E	C	P	Number of holes
				C _{Orad} [N]	C _{Oax} [N]									
HTT	40	250	130	2100	on request	15	7.5	50	50	-	-	50	125	4
		300	180	2250								100	150	
		350	230	2350								150	175	
		400	260	2450								200	200	
		450	310	2550								250	225	
		500	340	2500								300	250	
		550	370	2450								150	275	6
		600	400	2400								175	300	
		650	430	2350								200	325	
		700	460	2300								225	350	
		750	490	2250								250	375	
		800	520	2150								275	400	
		850	550	2050								300	425	
		900	600	1950								325	450	
		950	630	1800								350	475	
		1000	660	1650								375	500	

The load capacity for aluminum is 40% and for stainless steel 60% of the stated values, if available in this material variant (see Technical features overview).

* For double-sided stroke the dimension X1=7,5mm

Tab. 2

> HTT050

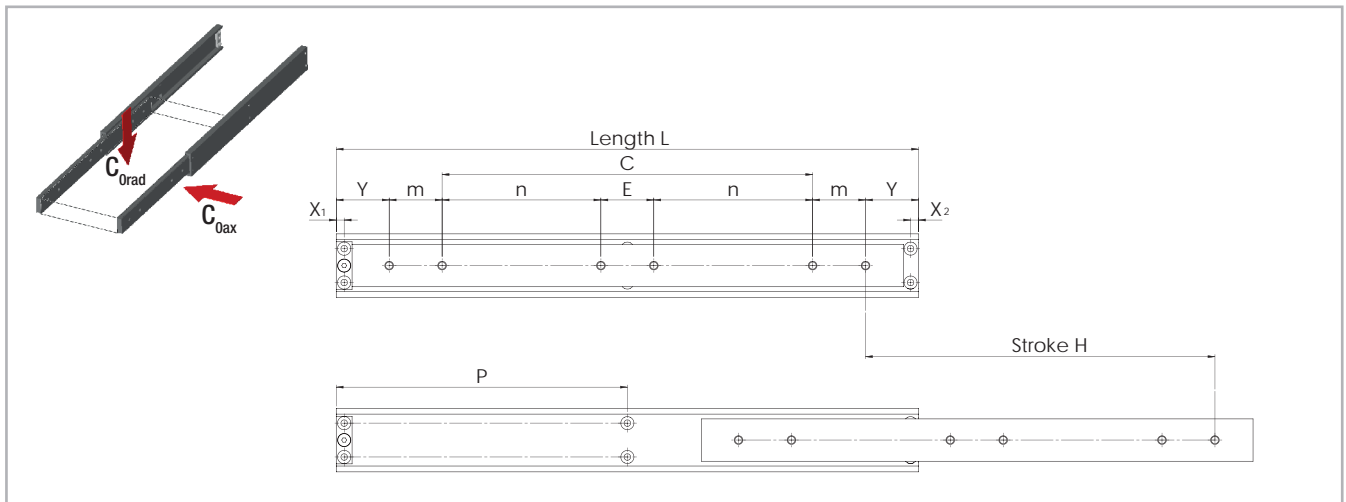

All dimensions are indicated in mm

Fig. 31

Type	Size	Length L [mm]	Stroke H [mm]	Load capacity per pair		X1*	X2	Y	m	n	E	C	P	Number of holes
				C _{Orad} [N]	C _{Oax} [N]									
HTT	50	300	180	2500	on request	15	7.5	50	50	-	-	100	150	4
		350	230	2600								150	175	
		400	260	2700								200	200	
		450	310	2800								250	225	
		500	340	2900								300	250	6
		550	370	2850								150	275	
		600	400	2800								175	300	
		650	430	2700								200	325	
		700	460	2600								225	350	
		750	490	2500								250	375	
		800	520	2400								275	400	
		850	550	2300								300	425	
		900	600	2200								325	450	
		950	630	2100								350	475	
		1000	660	2000								375	500	
		1100	700	1850								425	525	
1200	760	1650	475	550										

The load capacity for aluminum is 40% and for stainless steel 60% of the stated values, if available in this material variant (see Technical features overview).
 * For double-sided stroke the dimension X1=7,5mm

Tab. 3

> HTT

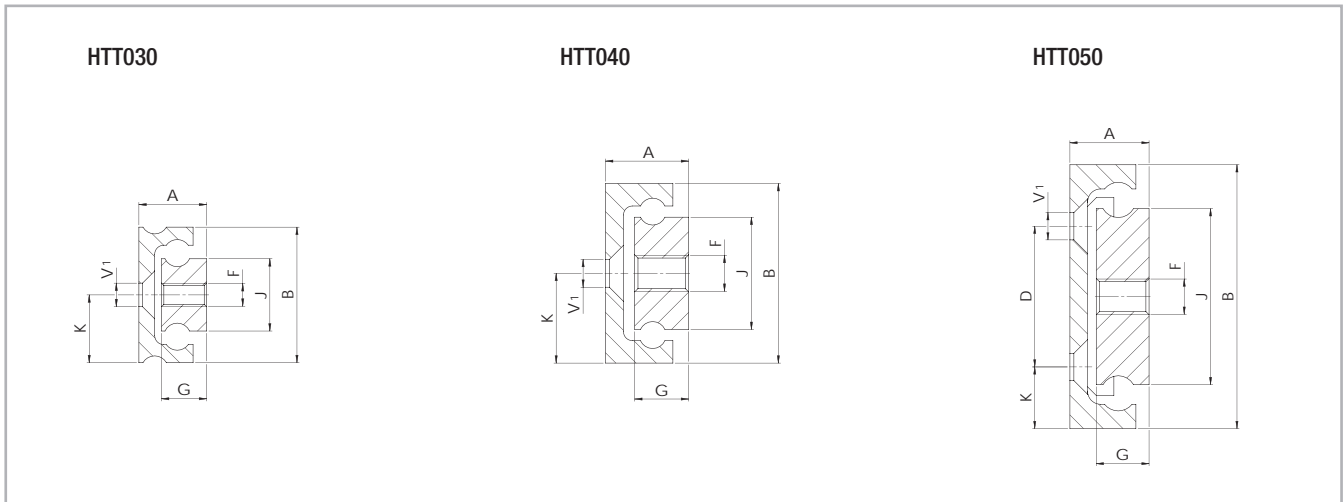

All dimensions are indicated in mm
 * Mounting holes (V) for countersunk screws according to DIN 7991/ISO 10642

Fig. 32

Type	Size	A	B	J	G	K	D	D1	F	V1	Weight per single guide [kg/m]
HTT	30	15	30	16	10	15	-	-	M6	M5	2.4
	40	18.5	40	25	12	20	-	-	M8	M6	4.3
	50	19.5	50	30	12.5	25	25	5.6			

Tab. 4

> HVC045, HVC050, HVC058, HVC075

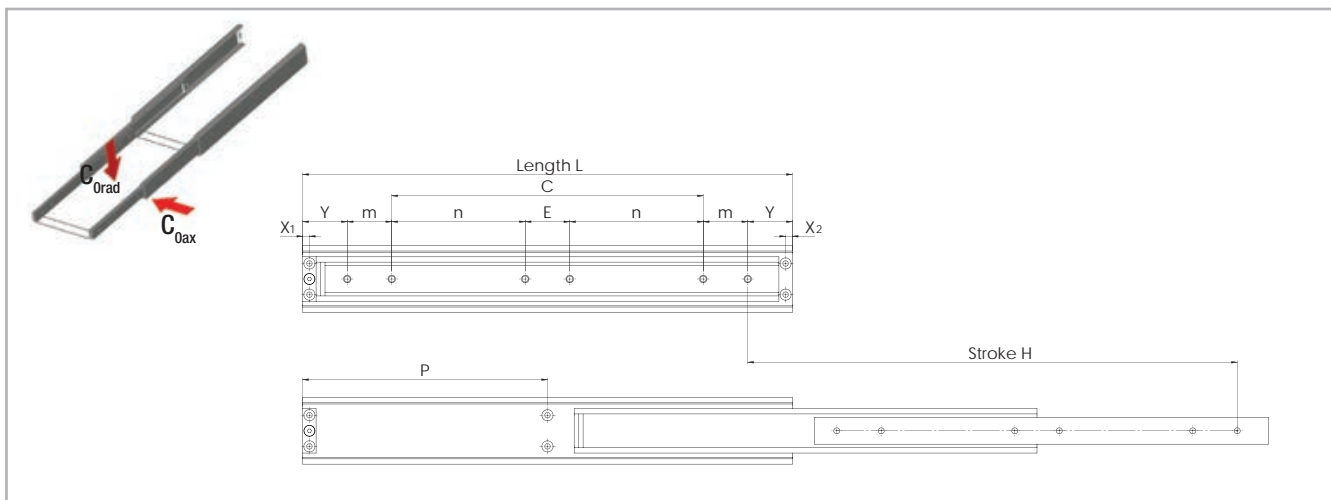

All dimensions are indicated in mm

Fig. 33

Type	Size	Length L [mm]	Stroke H [mm]	Load capacity per pair		X1	X2	Y	m	n	E	C	P	Number of holes
				C _{Orad} [N]	C _{Oax} [N]									
HVC	45	300	300	1150	on request	7.5	7.5	50	50			100		4
		350	350	1200								150		
		400	400	1200								200		
		450	450	1150								250		
		500	500	1150								300		
		550	550	1100								-	275	
		600	600	1050								150	300	
		650	650	1000								175	325	
		700	700	950								200	350	
		750	750	900								225	325	
		800	800	850								250	400	
		850	850	800								275	425	
		900	900	750								300	450	
		950	950	700								325	475	
		1000	1000	650								350	500	
1100	1100	500	375	50										
1200	1200	400	425	600										
				475	-								6	

Tab. 5

H
R

4 Load capacities and dimensions

Type	Size	Length	Stroke	Load capacity per pair		X1	X2	Y	m	n*	E*	C	P	Number of holes	
				C _{Grad} [N]	C _{0ax} [N]										
HVC	50	300	300	1400	on request	7.5	7.5	50	50	-	-	100	-	4	
		350	350	1450								150			
		400	400	1500								200			
		450	450	1450								250			
		500	500	1400								300			
		550	550	1350								150			275
		600	600	1300								175			300
		650	650	1250								200			325
		700	700	1200								225			350
		750	750	1150								250			325
		800	800	1100								275			400
		850	850	1050								300			425
		900	900	1000								325			450
		950	950	950								350			475
		1000	1000	900								375			500
		1100	1100	800								425			550
		1200	1200	700								475			600
		1300	1300	600								525			650
		1400	1400	500								575			700
		1500	1500	400								625			750

*When using full telescopes with interlocks in the open state (VO) or with interlocks open and closed (VB) the following measures change:
n reduces by 35 mm - E increases to 120 mm.

Tab. 6

Type	Size	Length	Stroke	Load capacity per pair		X1	X2	Y	m	n*	E*	C	P	Number of holes			
				C _{Orad} [N]	C _{Oax} [N]												
HVC	58	300	300	2000	on request	7.5	7.5	50	50	-	-	100	-	4			
		350	350	2050								150					
		400	400	2100								200					
		450	450	2050								250					
		500	500	2000								300					
		550	550	1950								150			50	-	275
		600	600	1900								175					300
		650	650	1850								200					325
		700	700	1800								225					350
		750	750	1750								250					325
		800	800	1700								275		400			
		850	850	1650								300		425			
		900	900	1600								325		450			
		950	950	1500								350		475			
		1000	1000	1450								375		500			
		1100	1100	1350								425		550			
		1200	1200	1250								475		600			
		1300	1300	1150								525		650			
		1400	1400	1050								575		700			
		1500	1500	1000								625		750			

The load capacity for stainless steel 60% of the stated values.
 *When using full telescopes with interlocks in the open state (VO) or with interlocks open and closed (VB) the following measures change:
 n reduces by 35 mm - E increases to 120 mm.

Tab. 7

4 Load capacities and dimensions

Type	Size	Length L [mm]	Stroke H [mm]	Load capacity per pair		X1	X2	Y	m	n*	E*	C	P	Number of holes
				C _{Grad} [N]	C _{Max} [N]									
HVC	75	300	300	3200	on request	7.5	7.5	50	50	-	-	100	-	4
		350	350	3250								150		
		400	400	3300								200		
		450	450	3250								250		
		500	500	3200								300		
		550	550	3150						150	50	-	275	6
		600	600	3100						175			300	
		650	650	3050						200			325	
		700	700	3000						225			350	
		750	750	2950						250			325	
		800	800	2900						275			400	
		850	850	2850						300			425	
		900	900	2800						325			450	
		950	950	2750						350			475	
		1000	1000	2700						375			500	
		1100	1100	2600						425			550	
		1200	1200	2500						475			600	
		1300	1300	2350						525			650	
		1400	1400	2200						575			700	
		1500	1500	2050						625			750	
1600	1600	1900	675	800										
1700	1700	1750	725	50										
1800	1800	1600	775	900										
1900	1900	1450	825	950										
2000	2000	1300	875	1000										

*When using full telescopes with interlocks in the open state (VO) or with interlocks open and closed (VB) the following measures change:
n reduces by 35 mm - E increases to 120 mm.

Tab. 8

> HVC

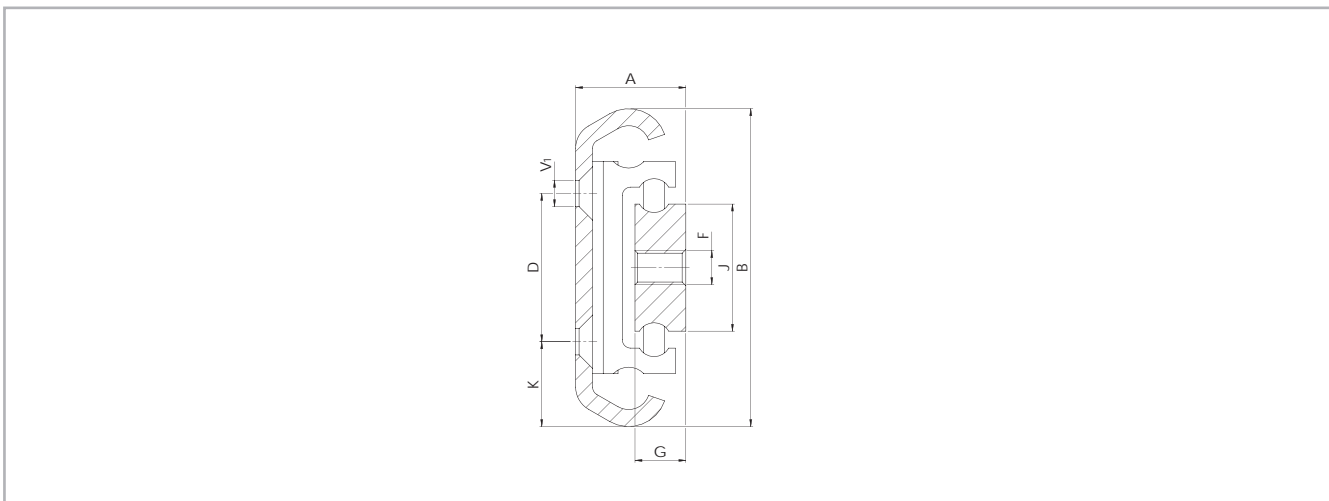

Fig. 34

All dimensions are indicated in mm
 V¹ Mounting holes (V) for countersunk screws according to DIN 7991/ISO 10642

Type	Size	A	B	J	G	K	D	F	V1	Weight per single guide [kg/m]
HVC	45	20.5	45	16	10	11.5	22	M6	M5	4.00
	50	22.1	50	20	12	14				5.10
	58	24	58	25		20	13	32	M8	M6
	75	26	75	30	20		35	9.30		

Tab. 9

H
R

H1C075

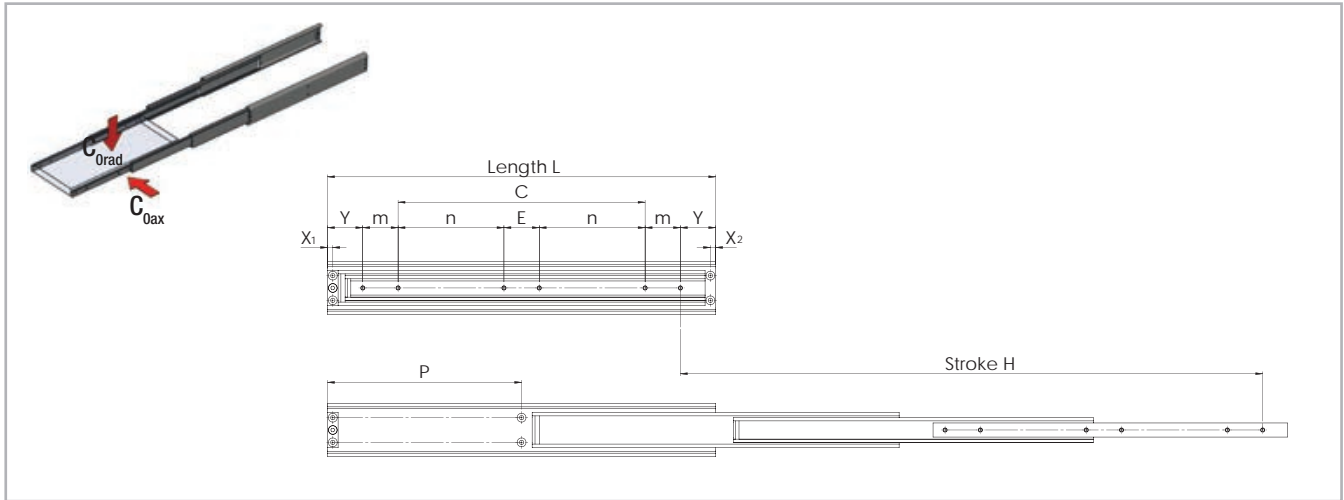

All dimensions are indicated in mm

Fig. 35

Type	Size	Length	Stroke	Load capacity per pair C_{Orad} [N]	X1	X2	Y	m	n	E	C	P	Number of holes
		L [mm]	H [mm]										
H1C	75	300	450	1200	7.5	7.5	50	50	-	50	100	-	4
		350	525	1250							150		
		400	600	1300							200		
		450	675	1350							250		
		500	750	1300							300		
		550	825	1200							150	275	6
		600	900	1150							175	300	
		650	975	1100							200	325	
		700	1050	1050							225	350	
		750	1125	1000							250	325	
		800	1200	950							275	400	
		850	1275	900							300	425	
		900	1350	850							325	450	
		950	1425	800							350	475	
		1000	1500	750							375	500	
		1100	1650	650							425	550	
		1200	1800	550							475	600	
		1300	1950	450							525	650	
		1400	2100	350							575	700	
		1500	2250	200							625	750	

Tab. 10

> H1C075

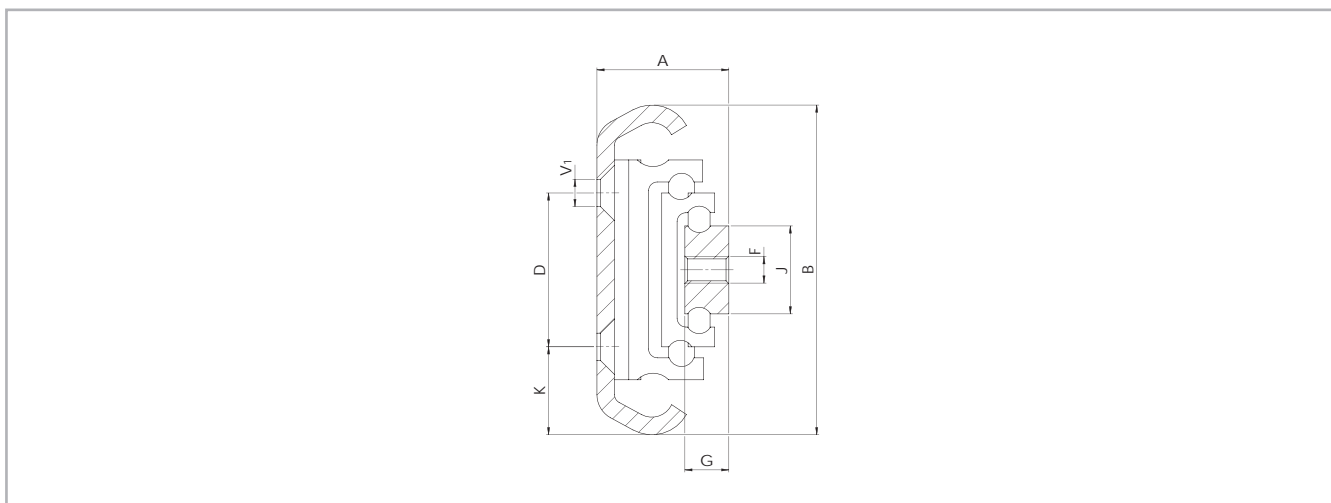

Fig. 36

All dimensions are indicated in mm
 V1 Mounting holes (V) for countersunk screws according to DIN 7991/ISO 10642

Type	Size	A	B	J	G	K	D	F	V1	Weight per single guide [kg/m]
H1C	75	30	75	20	10	20	35	M6	M6	8.60

Tab. 11

> H1T060, H1T080

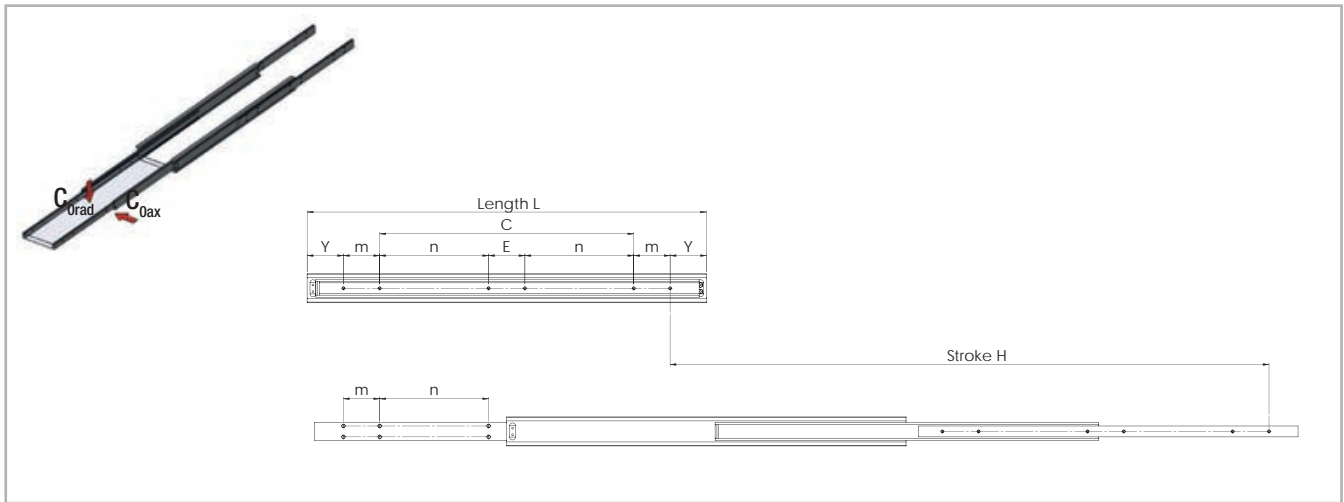

All dimensions are indicated in mm

Fig. 37

Type	Size	Length L [mm]	Stroke H [mm]	Load capacity per pair C_{Orad} [N]	Y	m	n	E	C	Number of holes		
										M6	M8	
H1T	60	300	450	2400	50	50				100	8	4
		350	525	2500						150		
		400	600	2550						200		
		450	675	2600						250		
		500	750	2600						300		
		550	825	2550			150	50	-	-	12	6
		600	900	2500			175					
		650	975	2450			200					
		700	1050	2400			225					
		750	1125	2350			250					
		800	1200	2300			275					
		850	1275	2250			300					
		900	1350	2200			325					
		950	1425	2150			350					
		1000	1500	2100			375					
		1100	1650	2000			425					
		1200	1800	1850			475					
		1300	1950	1700			525					
		1400	2100	1550			575					
		1500	2250	1400			625					

The load capacity for aluminum is 40% and for stainless steel 60% of the stated values, if available in this material variant (see Technical features overview).

Tab. 12

Type	Size	Length		Stroke		Load capacity per pair C _{0rad} [N]	Y	m	n	E	C	Number of holes			
		L [mm]	H [mm]	M8	M10										
H1T	80	500	750	3100	100	100	-	-	-	-	100	4	8		
		550	825	3150							150				
		600	900	3200							200				
		650	975	3150							250				
		700	1050	3100							300				
		750	1125	3000							350				
		800	1200	2900							400				
		850	1275	2800							450				
		900	1350	2700							500				
		950	1425	2600							550				
		1000	1500	2500							600				
		1100	1650	2280							300	100	-	6	12
		1200	1800	2060							350				
		1300	1950	1840							400				
		1400	2100	1620							450				
		1500	2250	1400							500				

The load capacity for aluminum is 40% and for stainless steel 60% of the stated values, if available in this material variant (see Technical features overview).

Tab. 13

> H1T100, H1T150

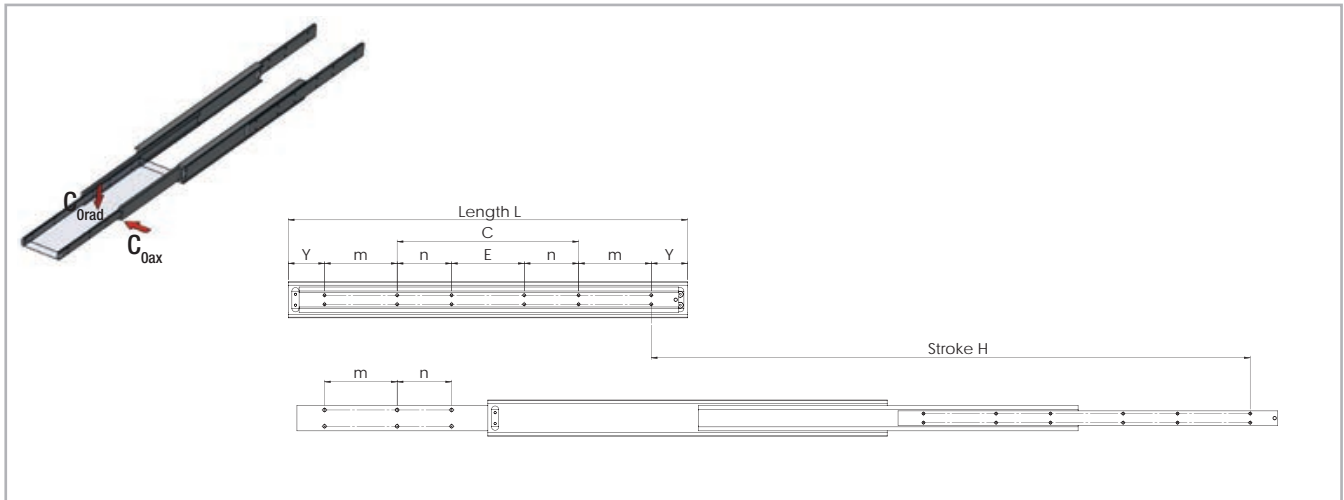

All dimensions are indicated in mm

Fig. 38

Type	Size	Length		Load capacity per pair C_{Orad} [N]	Y	m	n	E	C	Number of holes	
		L [mm]	H [mm]								
H1T	100	700	1050	5500	100	200				100	8
		750	1125	5500						150	
		800	1200	5300						200	
		850	1275	5100						250	
		900	1350	4700						300	
		950	1425	4500						350	
		1000	1500	4300						400	
		1100	1650	4000						150	
		1200	1800	3700			200				
		1300	1950	3400			250				
		1400	2100	3100			300				
		1500	2250	2900			350				
		1600	2400	2600			400				
		1700	2550	2300			450				
		1800	2700	2000			500				
		1900	2850	1700			550				
		2000	3000	1400			600				

The load capacity for aluminum is 40% and for stainless steel 60% of the stated values, if available in this material variant (see Technical features overview).

Tab. 14

Other sizes and versions are available on request

Type	Size	Length	Load capacity
		L [mm]	per pair C_{0rad} [N]
H1T	150	700	7000
		⋮	⋮
		2000	2300

Tab. 15

The load capacity for aluminum is 40 % and for stainless steel 60 % of the stated values, if available in this material variant (see Technical features overview).

> H1T

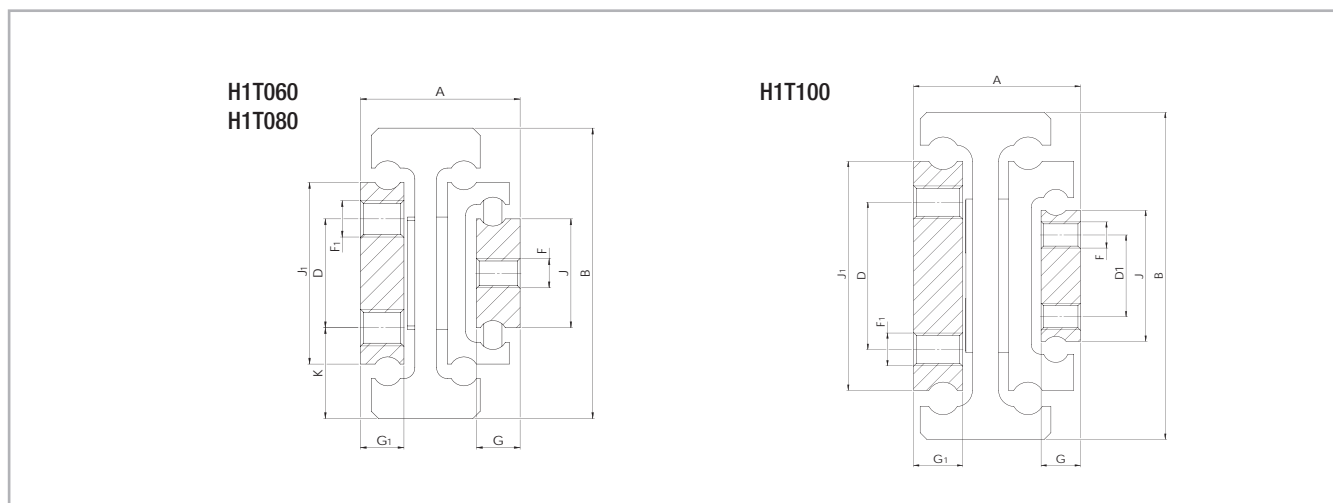

All dimensions are indicated in mm

Fig. 39

Type	Size	A	B	J	J1	G	G1	K	D	D1	F	F1	Weight per single guide [kg/m]
H1T	60	40.5	60	25	40	12	10	19	22	-	M8	M6	12.90
	80	44	80	30	50		12	25	30			M10	18.60
	100	51	100	40	70		15	27.5	45			25	M10

Tab. 16

> H2H080

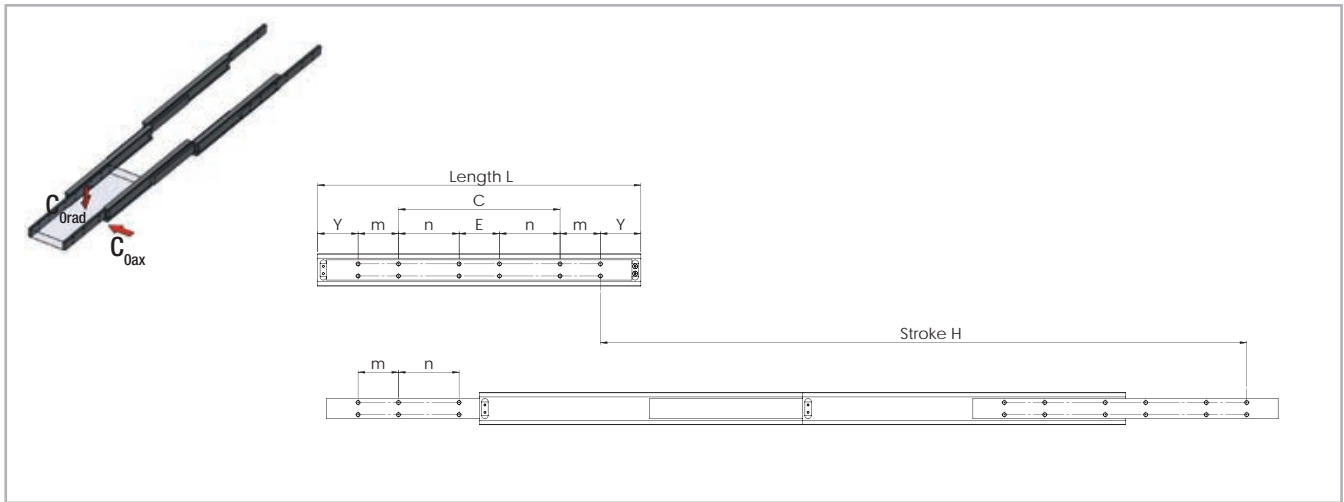

All dimensions are indicated in mm

Fig. 40

Type	Size	Length		Load capacity per pair C_{0rad} [N]	Y	m	n	E	C	Number of holes
		L [mm]	H [mm]							
H2H	80	500	1000	on request	100	100	-	-	100	8
		550	1100						150	
		600	1200						200	
		650	1300						250	
		700	1400						300	
		750	1500						350	
		800	1600				150	100	-	12
		850	1700				175			
		900	1800				200			
		950	1900				225			
		1000	2000				250			

The load capacity for aluminum is 40 % and for stainless steel 60 % of the stated values, if available in this material variant (see Technical features overview).

Tab. 17

> H2H080

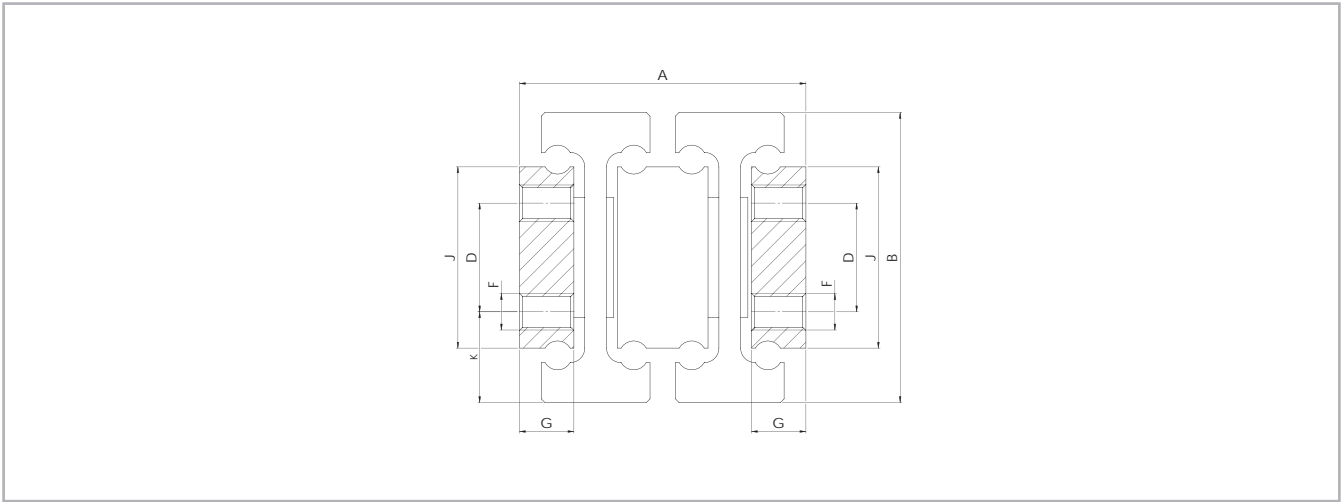

All dimensions are indicated in mm

Fig. 41

Type	Size	A	B	J	G	K	D	F	Weight per single guide [kg/m]
H2H	80	79+ -1	80	50	15	25	30	M10	34.80

Tab. 18

> LTH30 RF

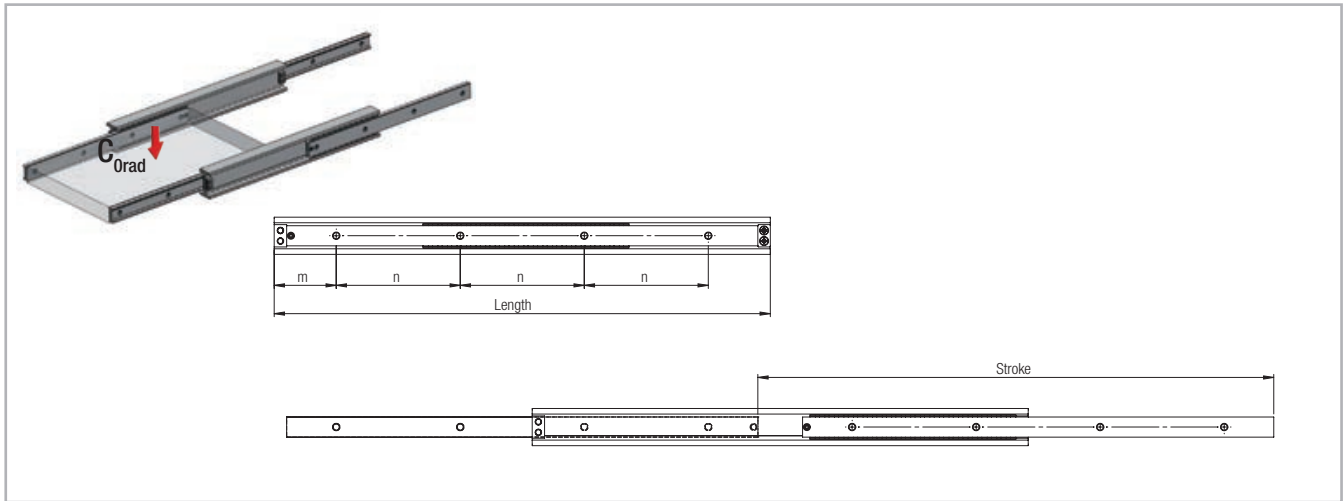

Fig. 42

Type	Size	Length		Stroke		Load capacity per pair		m [mm]	n [mm]	Number of holes
		L [mm]	H [mm]	C _{Orad} [N]	C _{Oax} [N]					
LTH	30	250	285	404	on request	25	100	3		
		300	323	1008		50				
		350	377	1042		25				
		400	416	1136		50		4		
		450	485	1164		25				
		500	523	1470		50		5		
		550	577	1464		25				
		600	615	1402		50		6		
		650	685	1230		25				
		700	723	1186		50		7		
		750	777	1100		25				
		800	815	1066		50		8		
		850	884	962		25				
		900	923	936		50		9		
		950	977	882		25				
		1000	1015	858		50		10		
		1050	1084	792		25				
		1100	1123	772		50		11		
1150	1176	736	25							
1200	1215	720	50	12						

Tab. 19

> LTH30 KF

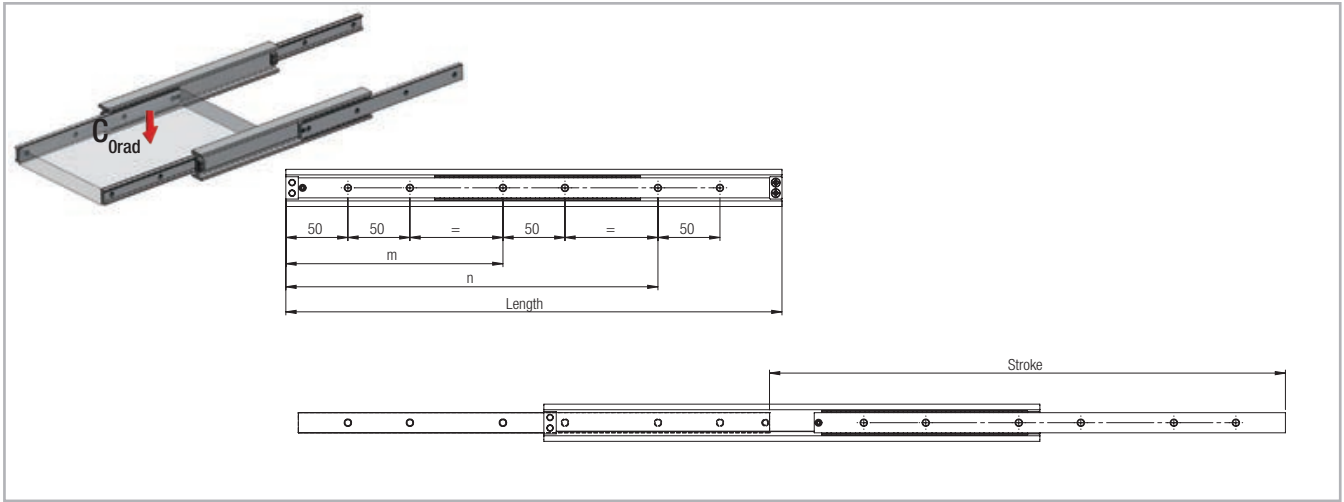

Fig. 43

Type	Size	Length L [mm]	Stroke H [mm]	Load capacity per pair		m [mm]	n [mm]	Number of holes
				C_{Orad} [N]	C_{Oax} [N]			
LTH	30	250	285	404	on request	-	150	4
		300	323	1008			200	
		350	377	1042			250	
		400	416	1136		175	300	6
		450	485	1164		200	350	
		500	523	1470		225	400	
		550	577	1464		250	450	
		600	615	1402		275	500	
		650	685	1230		300	550	
		700	723	1186		325	600	
		750	777	1100		350	650	
		800	815	1066		375	700	
		850	884	962		400	750	
		900	923	936		425	800	
		950	977	882		450	850	
		1000	1015	858		475	900	
		1050	1084	792		500	950	
		1100	1123	772		525	1000	
1150	1176	736	550	1050				
1200	1215	720	575	1100				

Tab. 20

> LTH30 S

... S version with reinforced and dampened end stops made of stainless steel

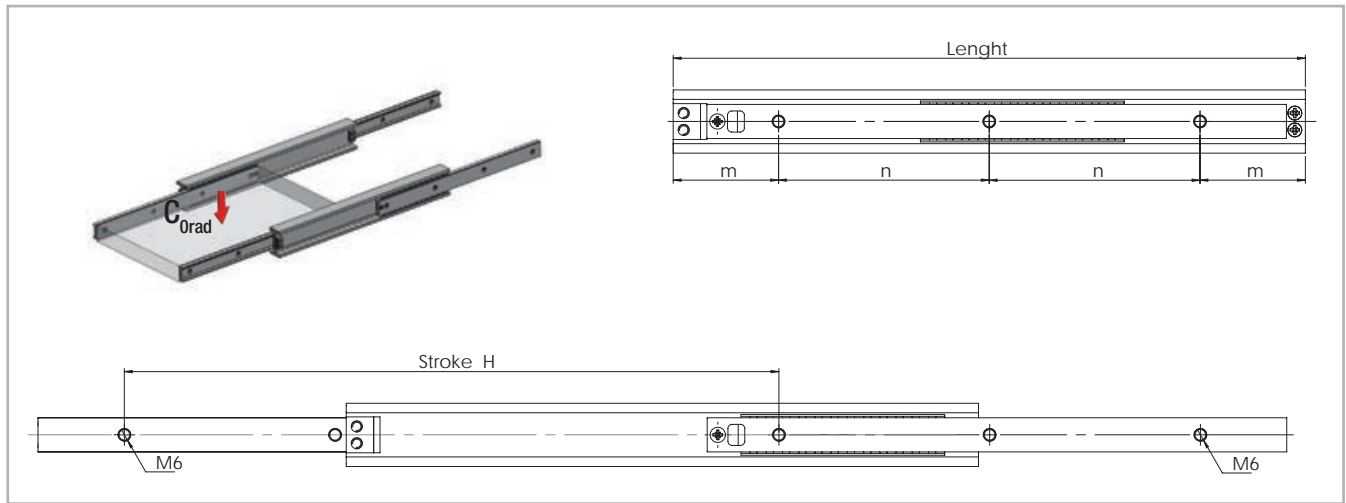

Fig. 44

Type	Size	Length L [mm]	Stroke H [mm]	Load capacity per pair		m [mm]	n [mm]	Number of holes
				C_{0rad} [N]	C_{0ax} [N]			
LTH...S	30	300	310	816	on request	50	100	3
		350	364	880		75		
		400	402	994		50		
		450	472	1032		75		4
		500	510	1330		50		
		550	564	1498		75		5
		600	618	1392		50		
		650	671	1276		75		6
		700	725	1178		50		
		750	764	1138		75		7
		800	817	1060		50		
		850	871	992		75		8
		900	925	932		50		
		950	979	878		75		9
		1000	1017	856		50		
		1050	1071	810		75		10
1100	1109	790	50					
1150	1179	732	75	11				
1200	1217	718	50					

Tab. 21

> LTH45 RF

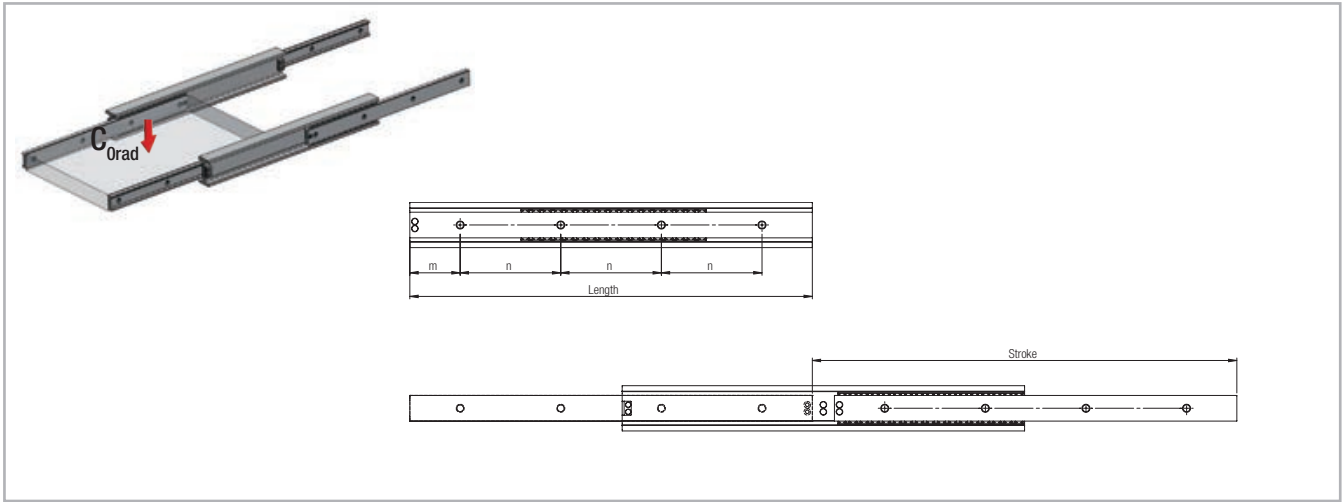

Fig. 45

Type	Size	Length L [mm]	Stroke H [mm]	Load capacity per pair		m [mm]	n [mm]	Number of holes
				C_{Orad} [N]	C_{Oax} [N]			
LTH	45	250	276	2610	on request	25	100	3
		300	310	2824		50		
		350	388	2820		25		4
		400	422	2842		50		
		450	478	2864		25		5
		500	512	2900		50		
		550	590	2764		25		6
		600	624	3032		50		
		650	680	3252		25		7
		700	714	3346		50		
		750	770	3084		25		8
		800	826	2860		50		
		850	882	2666		25		9
		900	916	2614		50		
		950	972	2450		25		10
		1000	1028	2306		50		
		1050	1084	2178		25		11
		1100	1118	2144		50		
		1150	1174	2034		25		12
		1200	1230	1934		50		
1250	1286	1842	25	13				
1300	1320	1818	50					
1350	1376	1738	25	14				
1400	1410	1716	50					
1450	1488	1596	25	15				
1500	1522	1578	50					

Tab. 22

> LTH45 KF

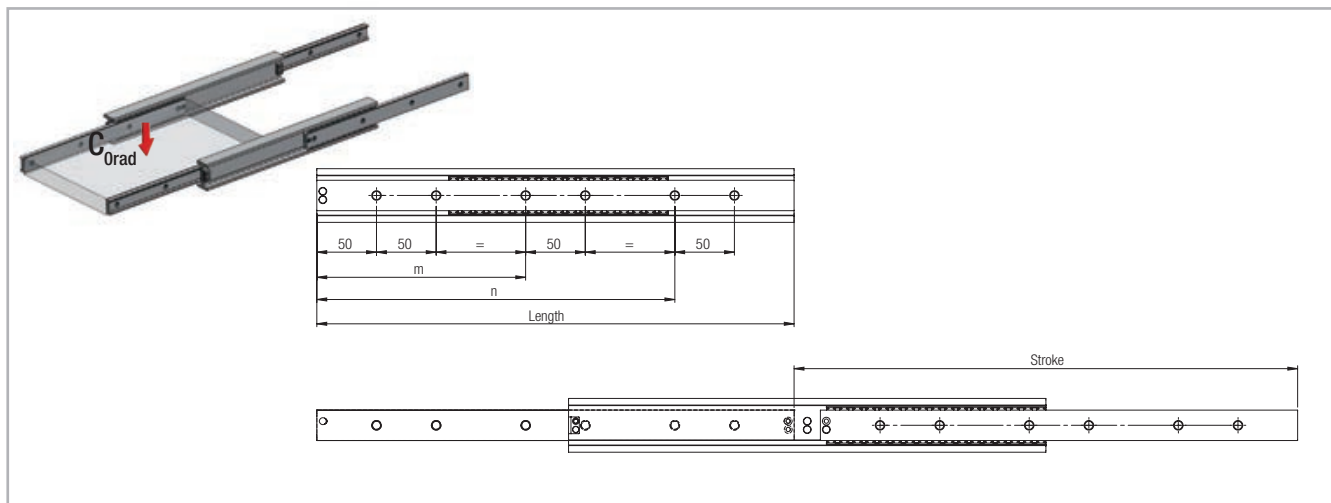

Fig. 46

Type	Size	Length L [mm]	Stroke H [mm]	Load capacity per pair		m [mm]	n [mm]	Number of holes
				C_{Orad} [N]	C_{Oax} [N]			
LTH	45	250	276	2610	on request	-	150	4
		300	310	2824			200	
		350	388	2820			250	
		400	422	2842			175	
		450	478	2864		200	350	6
		500	512	2900		225	400	
		550	590	2764		250	450	
		600	624	3032		275	500	
		650	680	3252		300	550	
		700	714	3346		325	600	
		750	770	3084		350	650	
		800	826	2860		375	700	
		850	882	2666		400	750	
		900	916	2614		425	800	
		950	972	2450		450	850	
		1000	1028	2306		475	900	
		1050	1084	2178		500	950	
		1100	1118	2144		525	1000	
		1150	1174	2034		550	1050	
		1200	1230	1934		575	1100	
1250	1286	1842	600	1150				
1300	1320	1818	625	1200				
1350	1376	1738	650	1250				
1400	1410	1716	675	1300				
1450	1488	1596	700	1350				
1500	1522	1578	725	1400				

> LTH45 S

... S version with reinforced and dampened end stops made of stainless steel

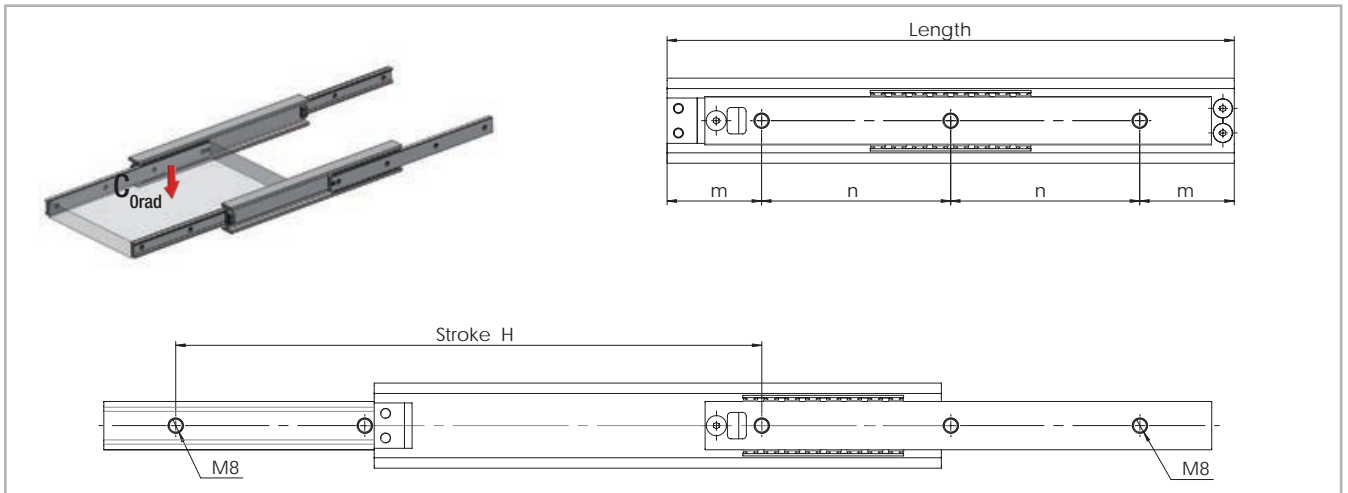
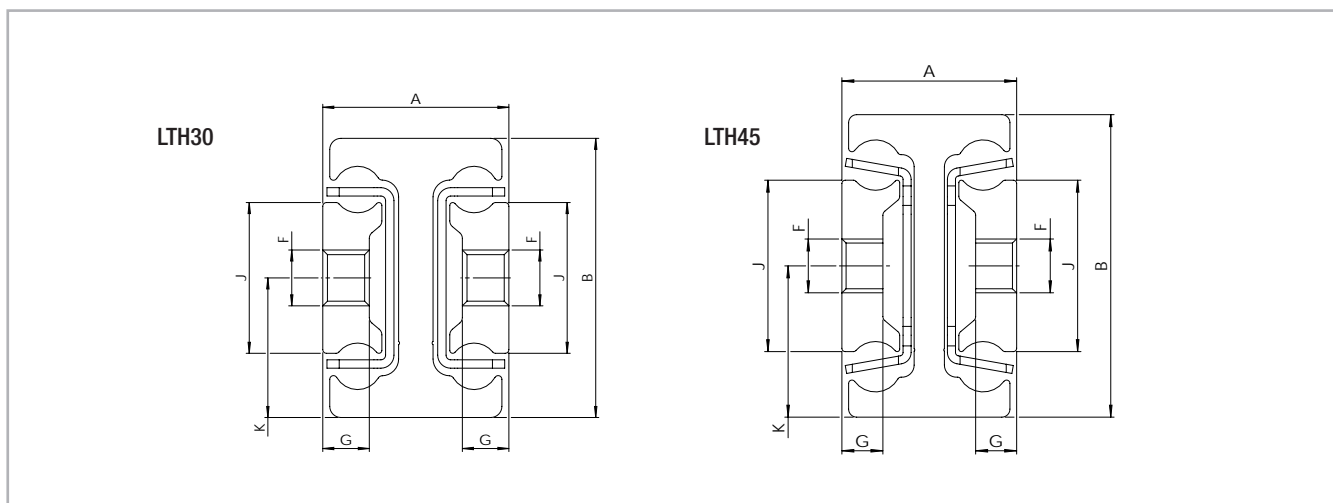

Fig. 47

Type	Size	Length L [mm]	Stroke H [mm]	Load capacity per pair		m [mm]	n [mm]	Number of holes
				C_{Orad} [N]	C_{Oax} [N]			
LTH...S	45	300	310	1316	on request	50	100	3
		350	366	1832		75		
		400	422	1666		50		4
		450	456	2154		75		
		500	512	1972		50		5
		550	568	2200		75		
		600	624	2204		50		6
		650	680	2426		75		
		700	714	2942		50		7
		750	770	3084		75		
		800	826	2860		50		8
		850	882	2666		75		
		900	916	2614		50		9
		950	972	2450		75		
		1000	1028	2306		50		10
		1050	1084	2178		75		
		1100	1118	2144		50		11
		1150	1174	2034		75		
		1200	1230	1934		50		12
		1250	1286	1842		75		
1300	1320	1818	50	13				
1350	1376	1738	75					
1400	1410	1716	50	14				
1450	1488	1596	75					
1500	1522	1578	50	15				

Tab. 24

> LTH



All dimensions are indicated in mm

Fig. 48

Type	Size	A	B	J	G	K	F	Weight per single guide [kg/m]
LTH	30	20	30	16.2	5.0	15.0	M6	3.5
	45	26	45	25.5	6.1	22.5	M8	6.0

Tab. 25

> LTH Special strokes

Special strokes are defined as deviations from standard stroke.

They are each available as multiples of the values in tab. 26.

These values are dependent on the spacing of the ballcage.

Type	Size	Stroke modification [mm]
LTH	30	15,4
	45	22

Tab. 26

Each stroke modification influences the load capacities stated in the catalogue. For more information please contact Rollon technical support.

> HGT060, HGT080, HGT100, HGT120, HGT150, HGT200, HGT240

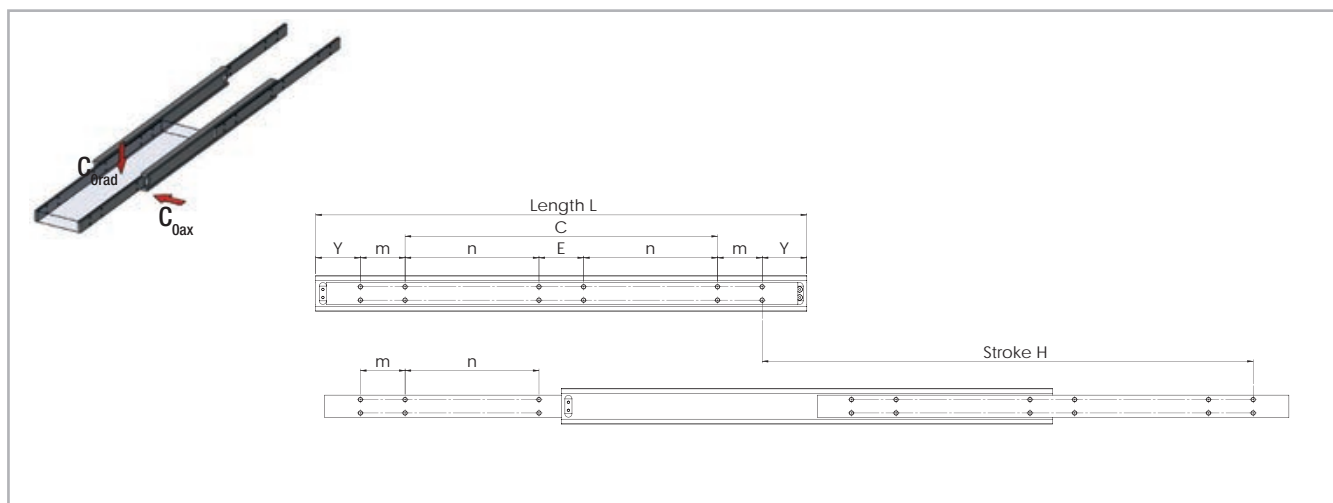

All dimensions are indicated in mm

Fig. 49

Type	Size	Length L [mm]	Stroke H [mm]	Load capacity per pair		Y	m	n	E	C	Number of holes					
				C _{Orad} [N]	C _{Oax} [N]											
HGT	60	400	400	5250	on request	50	50	-	-	200	8					
		450	450	5350						250						
		500	500	5400						300						
		550	550	5500						150	50	-	-			
		600	600	5400						175						
		650	650	5350						200						
		700	700	5250						225						
		750	750	5100						250						
		800	800	4900						275						
		850	850	4700						300						
		900	900	4500						325				50	-	12
		950	950	4300						350						
		1000	1000	4050						375						
		1100	1100	3700						425						
		1200	1200	3300						475						
		1300	1300	2900						525						
1400	1400	2500	575													
1500	1500	2100	625													

The load capacity for aluminum is 40% and for stainless steel 60% of the stated values, if available in this material variant (see Technical features overview).

Tab. 27

4 Load capacities and dimensions

Type	Size	Length	Stroke	Load capacity per pair		Y	m	n	E	C	Number of holes	
				L [mm]	H [mm]							C _{Grad} [N]
HGT	80	500	500	9000	on request	100	100			100	8	
		550	550	9250						150		
		600	600	9350						200		
		650	650	9200						250		
		700	700	9050						300		
		750	750	8800						350		
		800	800	8600						400		
		850	850	8350						450		
		900	900	8100						500		
		950	950	7850						550		
		1000	1000	7550				600				
		1100	1100	7150				300	100	-		12
		1200	1200	6700				350				
		1300	1300	6200				400				
		1400	1400	5700				450				
		1500	1500	5200				500				
		1600	1600	4600				550				
		1700	1700	4100				600				
		1800	1800	3600				650				
		1900	1900	3000				700				
2000	2000	2500	750									

The load capacity for aluminum is 40% and for stainless steel 60% of the stated values, if available in this material variant (see Technical features overview).

Tab. 28

Type	Size	Length		Stroke		Load capacity per pair		Y	m	n	E	C	Number of holes		
		L [mm]	H [mm]	C _{Orad} [N]	C _{Oax} [N]										
HGT	100	700	700	11000	on request	100	200	-	-	-	100	8			
		750	750	10750							150				
		800	800	10500							200				
		850	850	10250							250				
		900	900	10000							300				
		950	950	9750							350				
		1000	1000	9500							400				
		1100	1100	9000							150		200	-	12
		1200	1200	8500							200				
		1300	1300	7900							250				
	1400	1400	7300	300											
	1500	1500	6700	350											
	1600	1600	6100	400											
	1700	1700	5450	450											
	1800	1800	4800	500											
	1900	1900	4100	550											
	2000	2000	3400	600											

The load capacity for aluminum is 40% and for stainless steel 60% of the stated values, if available in this material variant (see Technical features overview).

Tab. 29

Other sizes and versions are available on request

Type	Size	Length		Load capacity per pair	
		L [mm]	C _{Orad} [N]	C _{Oax} [N]	
HGT	120	700	11500	on request	
		⋮	⋮		
		2000	4700		
	150	700	13900		
		⋮	⋮		
		2000	7000		
	200	700	15000		
		⋮	⋮		
		2000	10000		
	240	700	17500		
		⋮	⋮		
		2000	12500		

The load capacity for aluminum is 40% and for stainless steel 60% of the stated values, if available in this material variant (see Technical features overview).

Tab. 30

> HGT

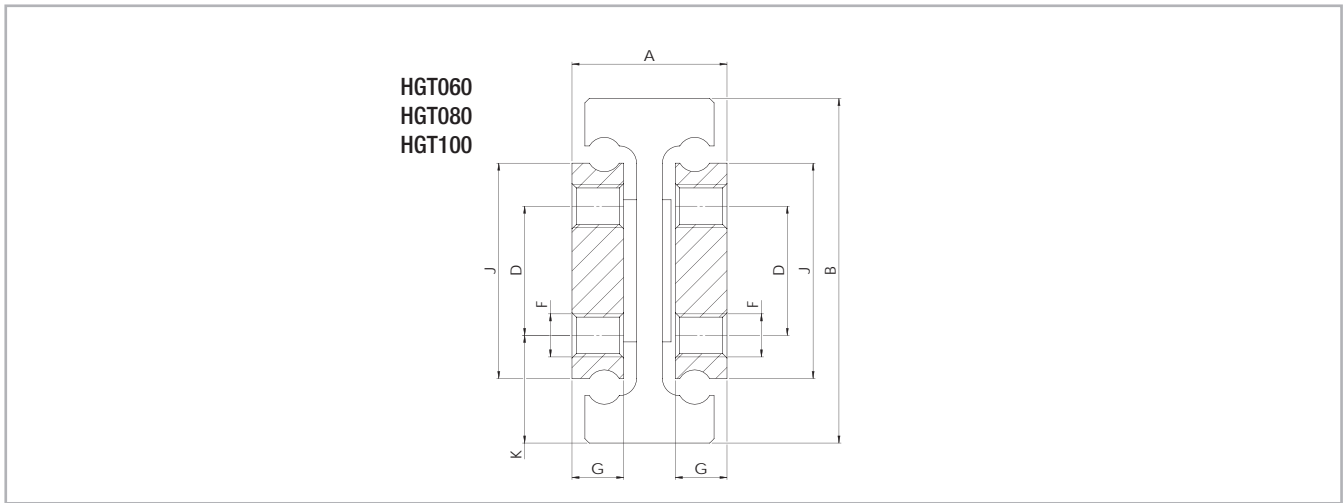

All dimensions are indicated in mm

Fig. 50

Type	Size	A	B	J	G	K	D	F	Weight per single guide [kg/m]
HGT	60	32	60	40	10	19	22	M6	11.70
	80	36	80	50	12	25	30	M10	17.50
	100	44	100	70	15	27.5	45		27.60

Tab. 31

> LTF44

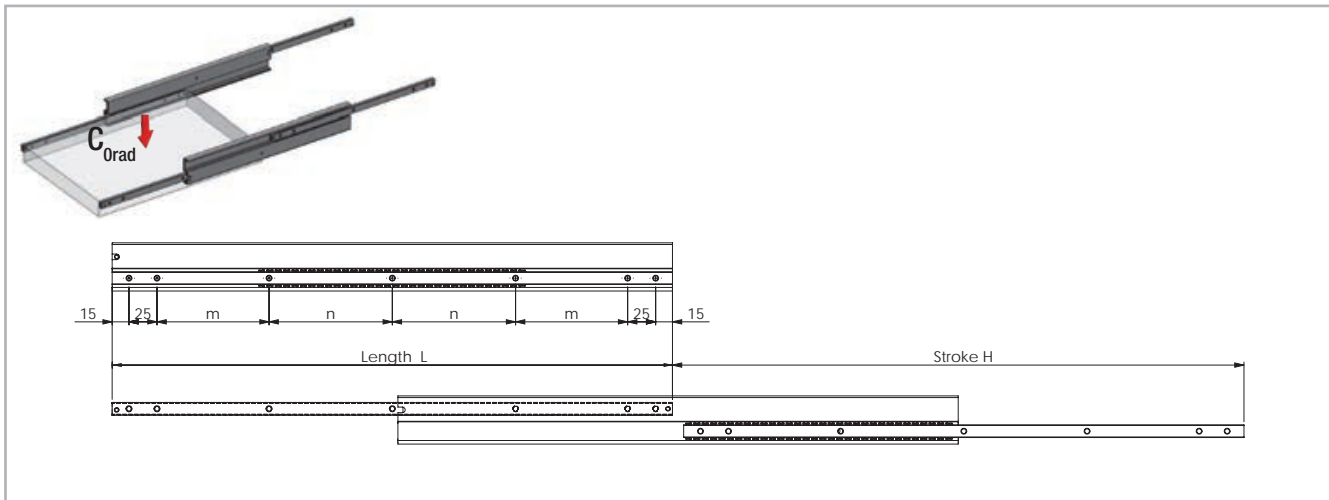

All dimensions are indicated in mm

Fig. 51

Type	Size	Length	Stroke	Load capacity per pair C_{Orad} [N]	Fixed and moving rails		Number of holes
		L [mm]	H [mm]		m [mm]	n [mm]	
LTF	44	200	210	228	60	-	5
		225	235	260	72.5		
		250	260	288	85		
		275	285	324	97.5		
		300	310	360	110		
		325	335	392	122.5		
		350	360	420	135		
		375	385	452	147.5		
		400	410	492	160		
		425	435	524	172.5		
	450	460	552	185	100	7	
	500	510	624	110			
	550	560	684	135			
	600	610	768	160			
	650	660	816	185			
	700	710	888	160			
	750	760	948	185			
	800	810	1020	210			
	850	860	1080	235			
	900	910	1152	260			
950	960	1224	285	150	310		
1000	1010	1296	310				

Tab. 32

> LTF44

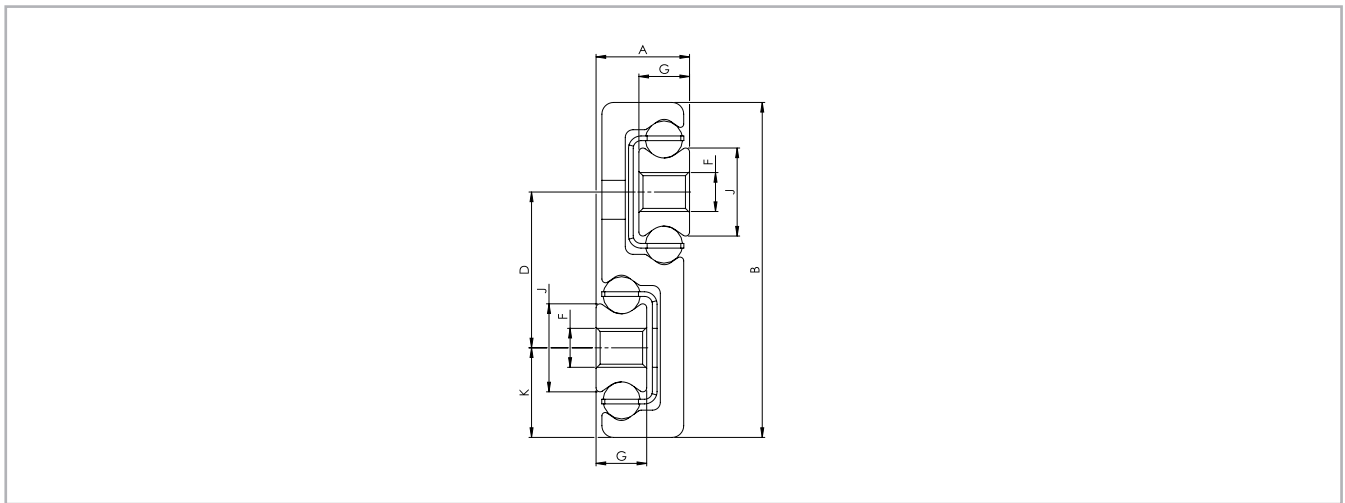

All dimensions are indicated in mm

Fig. 52

Type	Size	A	B	J	G	K	D	F	Weight per single guide [kg/m]
LTF44	44	12	43	11.3	6.5	11.5	20	M5	2.7

Tab. 33

> HGS060

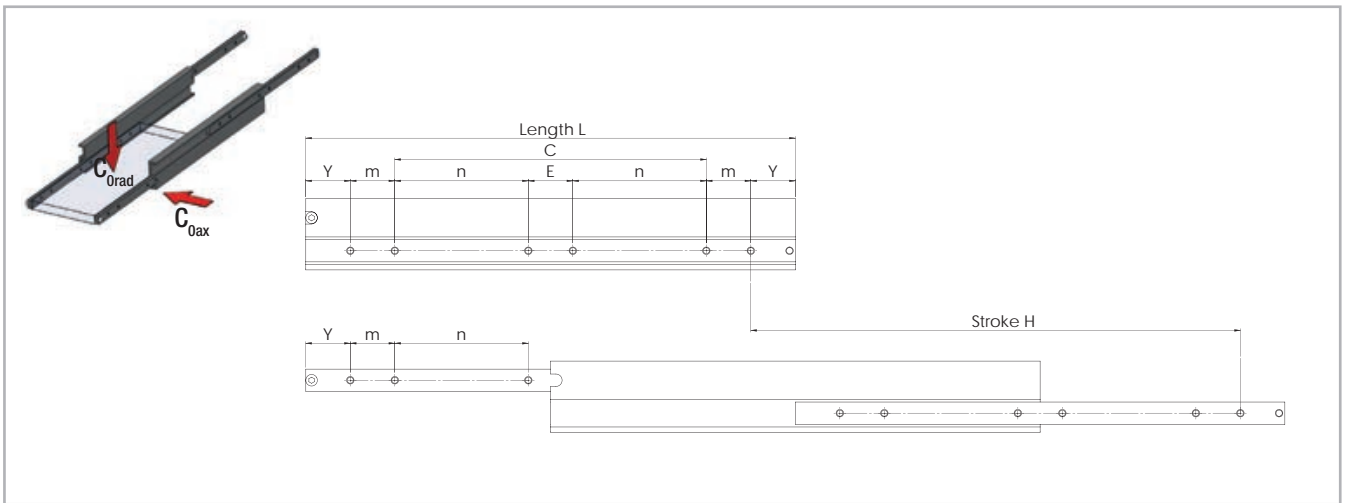

All dimensions are indicated in mm

Fig. 53

Type	Size	Length	Stroke	Load capacity per pair C_{0rad} [N]	Y	m	n	E	C	Number of holes	
		L [mm]	H [mm]								
HGS	60	250	250	1000	50	50				50	4
		300	300	1250						100	
		350	350	1350						150	
		400	400	1400						200	
		450	450	1400						250	
		500	500	1400						300	
		550	550	1350			150	50	-	-	6
		600	600	1300			175				
		650	650	1250			200				
		700	700	1200			225				
		750	750	1150			250				
		800	800	1050			275				
		850	850	950			300				
		900	900	850			325				
		950	950	750			350				
		1000	1000	650			375				

The load capacity for aluminum is 40% of the stated values,

Tab. 34

> HGS

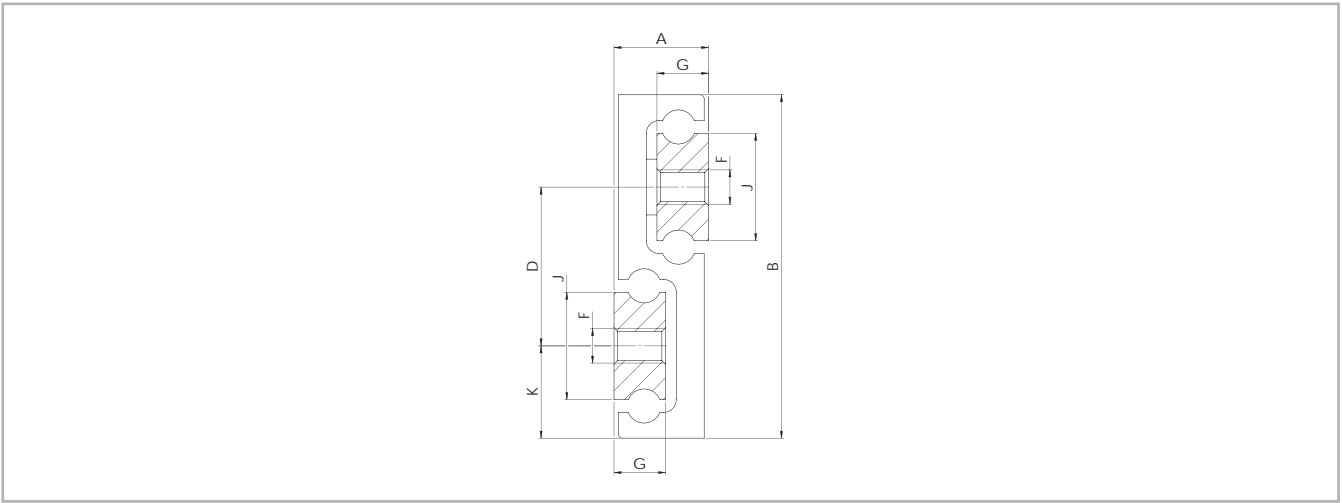

All dimensions are indicated in mm

Fig. 54

Type	Size	A	B	J	G	K	D	F	Weight per single guide [kg/m]
HGS	60	17	60	16	10	16	28	M6	6.00

Tab. 35

Accessories

Available options (depending on telescope version)

> Locking

Locking mechanisms make it possible to lock the Hegra rails in the end position. This prevents inadvertent extension or retraction of the rail in any case. Locking mechanisms can be implemented as locking bolts or bars. This ensures personal safety and protection of materials, especially in moving installations, as in vehicles. For models HGT with locking please observe right or left side use.



Fig. 55



Fig. 56

> Driving disc

In the full extension rails with dual stroke the intermediate element does not follow a particular order. The exact position of the element is therefore defined only in fully extended condition. The optional driving disc defines the movement of the intermediate element. This prevents unwanted protrusion of the element. An example for use of the driving disc is in warehouse rails, which are extended in both directions.



Fig. 57



Fig. 58

> Damping

Hegra telescoping rails can be equipped with damped end stops in closed position. Plastic or elastomer damping elements provide for quieter operation, a softer end stop when pushing in the rail and higher resistance at the end of the stroke.

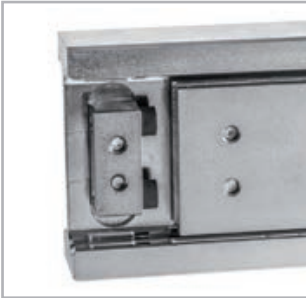

Fig. 59

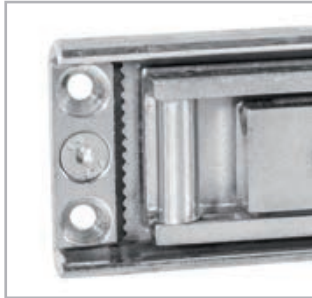

Fig. 60

> Snap

Hegra Rail telescopic guides can be partial with a snap through a ball thrust piece. Thus, an unintended process of the telescope system is avoided.

Note: Not all accessories (interlocks, damping, Drive disk, snap) can be combined with each other and available. (see Technical features overview) Please contact our technical service.

Technical information



> Selecting a suitable telescoping rail

To find a telescoping rail that meets your requirements, the following factors must be considered.

- Desired load capacity
- Available sizes (height, width and rail length)
- Required extension type (partial, full extension, etc.)
- Length of travel
- Desired material and surface

> Mounting tolerances

Installation

length (mm)	$\geq 150 < 420$	$\geq 420 < 1050$	$\geq 1050 < 2840$
Tolerance (mm)	± 0.5	± 0.8	± 1.2

At the installation, width tolerances of ± 0.5 mm for compensating are to be considered. For all other dimensions, the tolerances according to DIN ISO 2768-1 (m) apply.

> Life cycle

The life cycle describes the time span from installation to failure of the telescoping rail, due to wear.

The life cycle is affected by the following factors.

- Load
- Assembly precision
- Parallelism when installed in pairs
- Rigidity of the connection construction
- Jolts and vibrations
- Operating temperature
- Lubrication (in accordance with maintenance intervals)

> Load capacity

The specified maximum load capacity always refers to one pair of vertically installed telescoping rails. To achieve this capacity, the following requirements must be fulfilled.

- An absolutely rigid connection construction
- Even distribution of the load over the entire length of the moving rail element
- Mounting of the telescoping rails on a flat and rigid surface using all provided mounting holes
- Please be sure to use the correct screw length to prevent damage to the ball cage: shank length of screw < thickness of the moving element
- Vertical installation of telescoping rails

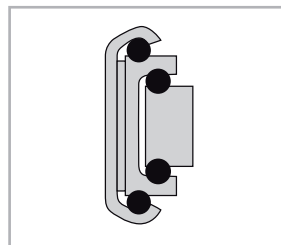

Vertical installation

Fig. 61

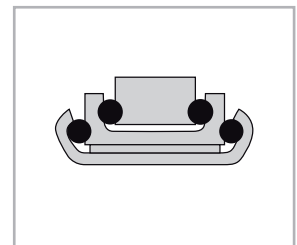

Level installation

Fig. 62

If optimal implementation of all of these requirements is not possible, we will be glad to assist you in calculating the actual load capacity.

In case of a level installation of the telescoping rails (axial load direction), only a reduced value of the radial load capacity is possible.

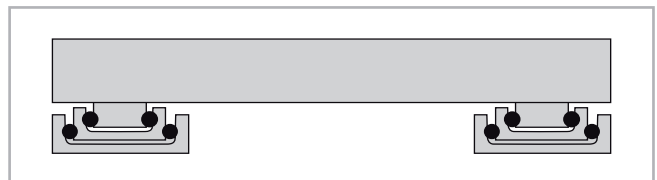

Fig. 63

> Deflection

If the telescopic guides of the HGT series are assembled in pairs and the requirements under "Load capacity" are taken into account, the maximum deflection of steel rails under full load is 1 % of the extended length (stroke). Example: 500 mm length of travel -> max. 5 mm deflection under full load.

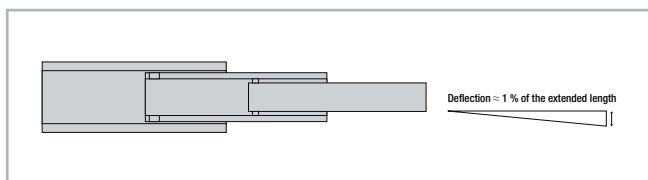

Fig. 64

Note: All other deflection of the Hegra Rail product family on request

> Operating temperature

The telescopic rails can be used at ambient temperatures from -20 °C to +170 °C (-4 °F to +338 °F). At lower temperatures down to -30 °C (-22 °F) or higher temperatures up to +250 °C (+482 °F), please contact our application engineers. These ranges always require the use of a special lubricant. For temperature above 80°C all plastic parts, if they exist, must be removed

The operating temperature is -20 °C to + 50 °C (-4 °F to + 122 ° F) when damping is used.

> Corrosion protection

As standard features, all series are zinc electroplated, thick-film passivated and Reach/RoHs compliant. For higher corrosion protection we offer zinc nickel plating with stainless steel balls. Overview of available coatings:

Treatment	Characteristics
Thick-film passivation	Standard coating composed of a galvanic zinc coating and an additional passivation
Zinc nickel	Increase corrosion resistance due to a zinc nickel coating and the use of stainless steel balls

Tab. 36

> Ball cage displacement

The stroke movement of a telescopic rail is achieved by the ball cages, among other elements. You should ensure that the telescopic rail is always fully extended and retracted, since otherwise the ball cages can become displaced. Ball cage displacement occurs as a result of slippage and means that you can achieve the required extension length and the desired closed condition of the telescopic rail only with increased application of force.

Automated systems must have sufficient reserve driving force or an additional maximum stroke must be planned for in order to prevent displacement.

On request we also implement custom design solutions. Feel free to contact us.

> Moving force

The moving force is subject to production-related tolerances and is also defined by the load and the deflection of a telescopic rail. Taking into account the load and deflection of a telescopic rail, the closing force is higher than the opening force, since deflection occurs under load and closing takes place by pushing against a slanted plane.

> Lubrication

Alternative lubricants, for example for the food industry, or alternate temperature ranges are available on request. Our aluminium or stainless steel telescopic rails are generally delivered without grease.

> Maintenance intervals

A visual inspection should be conducted occasionally; foreign particles should be removed and “dry” guide rails should be lightly lubricated with roller bearing grease. This prevents friction, protects the components and prolongs the life of the system. The lubrication intervals are variable and should be determined based on the respective operating conditions such as load, ambient conditions, travel speed, temperature, pollution, etc.

> Mounting instructions

- Please use all mounting holes, in addition to screws of the correct length.
- A stable base is necessary for mounting the telescoping rails.
- In the connection construction, be aware that we have switched to counterbores according to DIN 74 Form F and due to the material thickness of our profiles, the head of the countersunk screw protrudes somewhat from the profile, so that the mating piece must have a corresponding counterbore.

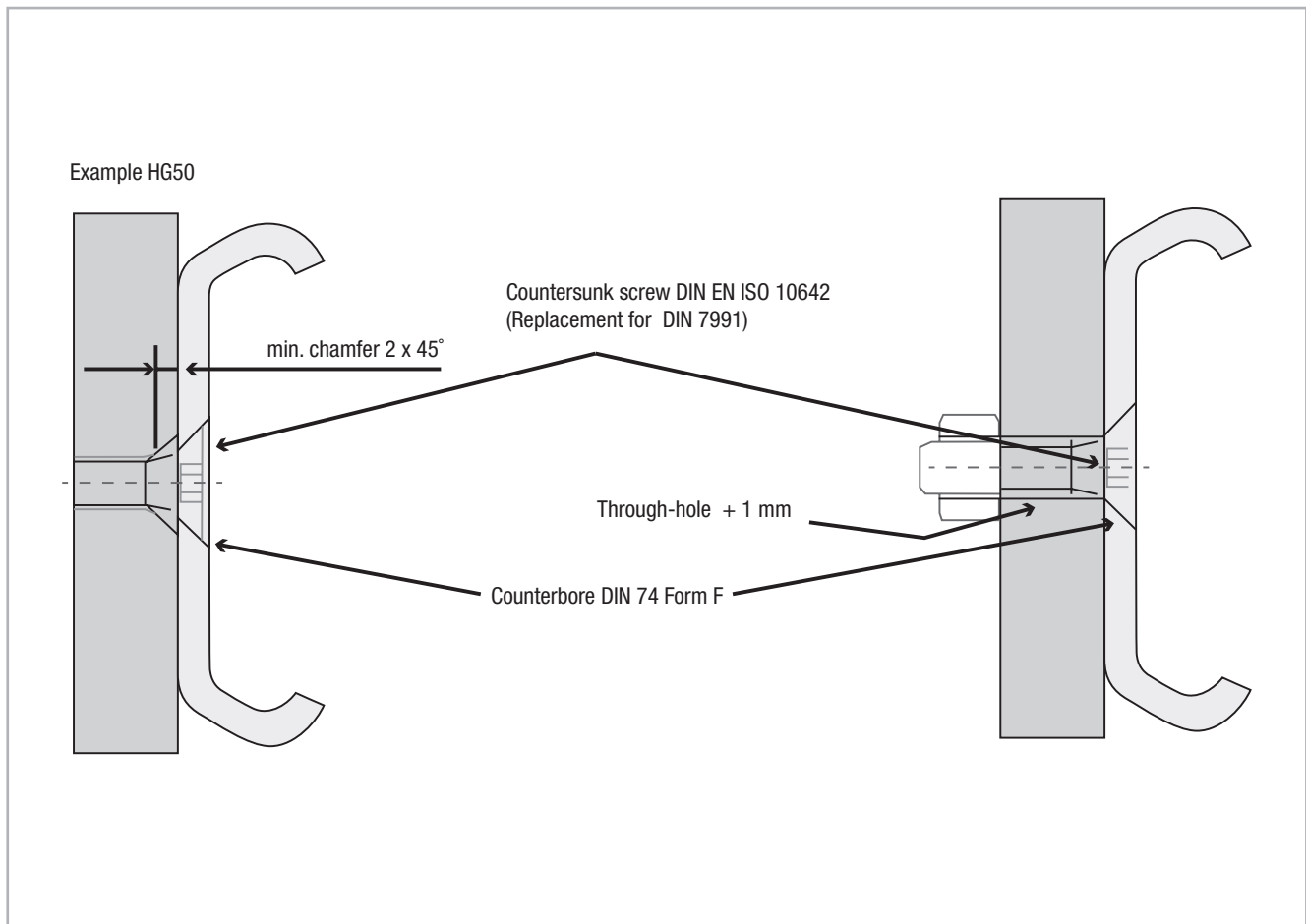

Fig. 65

Ordering key

> Hegra Rail

HGTX080	0500	0600	EG	VO	DG	B	Z	R	
									right or left version
									alternate coating
									stroke in both directions
									damping
									locking
									snap
									alternate stroke
									closed length
type with material and size									

Note on ordering: The size is always indicated as 3 digits, the length of the rail and the stroke are always 4 digits with the 0 prefixes.

Not all fields must be filled out. If they are not used, they remain empty.

Ordering example: HGTX080-0500-0600-EG-VO-DG-B-Z-R

Type	
HTT	partial extension machined/drawn profile
HVC	full extension single c-profile
H1C	over extension 150 % single c-profile
H1T	over extension 150 % machined/drawn profile
H2H	over extension 200 % machined/drawn profile
LTH	heavy duty slide
HGT	heavy duty slide
LTF	s-profile
HGS	s-profile

Material	
	steel
A	aluminum
X*	stainless steel

* Different stainless steels, such as the “electropolishing” option, are available, please contact our technical service.

*To process your order for stainless steel telescopic systems we need the material number you prefer. Please consider: Our standard material for rails and sliders in V2A is 1.4301 (AISI304), in V4A it is 1.4571 (AISI316Ti) and that the material of our stainless balls is 1.4034 (AISI420)

Accessory	
	no accessory
EO	snap on opened position
EG	snap on closed position
EB	snap on closed an opened position
VO	locking opened position
VG	locking closed position
VB	locking on closed an opened position
DG	damping closed position
B	stroke on closed an opened position
BM	stroke on closed an opened position with synchronization

Coating	
	thick-film passivation
Z	zinc nickel
N	nickel
E	anodizing colorless

Layout	
L	left version
R	right version

Special/Configuration	
S01	special (according to drawing)
C01	configuration (special stroke, stainless steel balls, special grease)

ROLLON[®]
BY TIMKEN

Telerace



NEW

New Telerace **PLUS**

Telescopic rail with double row ball bearings.
It simplifies and improves automations: **7 main advantages.**



1

Unique features: self-alignment and stroke customization

TLR: self-aligning version compensates dimensional differences between the structure and the drawer.

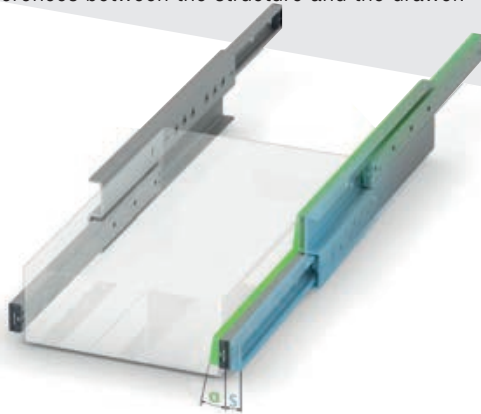

TLQ: Easy set the stroke length required by adjusting the distance of the sliders in the rail.

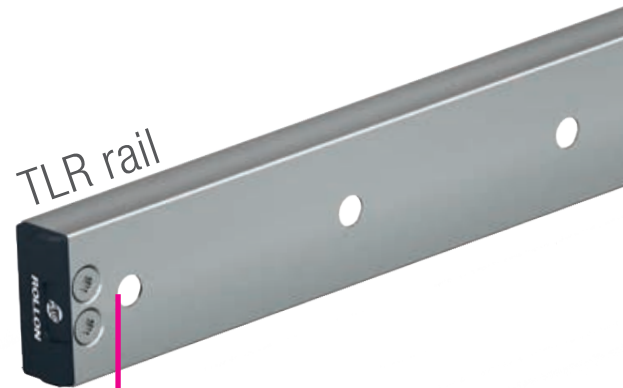
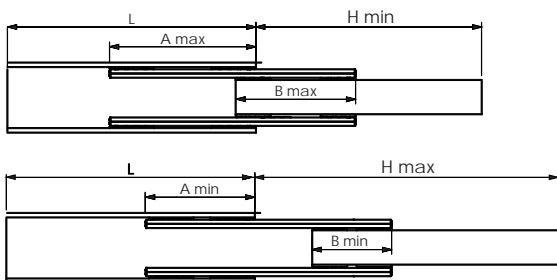

2

Ideal for automation

The use of ball bearings and robust end-stoppers allows to handle high dynamics and reduce cycle times.



3

Reliable vertical and variable stroke

The absence of the ball cage allows to perform automated vertical and variable strokes.



4

Low opening and closing force

Low deflection with sturdy profiles.

Ground raceways for a smooth and silent movement with low friction.

A full range of telescopic rails for your automations

Also available with single row ball bearings and rolled steel profiles hardened with Rollon-Nox treatment or made of stainless steel.



5

Optimal reliability in dirty environments

Large rolling elements make Telerace less sensitive to dirt and debris.

End-stoppers feature wipers with slow release felts for an optimal cleaning and constant lubrication of the raceways.



6

Long lifetime

Different hardening treatments according to the rail type and size.

- **Induction hardening:** hardened raceways with 1.2 mm effective depth and hardness between 58 and 62 HRC.
- **Rollon-Nox hardening:** treatment of deep nitriding and black oxidation.



7

Resistant to corrosion

Different surface treatments make Telerace reliable in harsh environments.

- **Indoor applications:** Zinc-plating ISO 2081.
- **Corrosive environments (humidity):** ZincNickel-plating ISO19598.
- **Corrosive environments (acidic or basic):** nickel-plating.

Product explanation



> Telescopic rails with rollers designed for industrial automations.

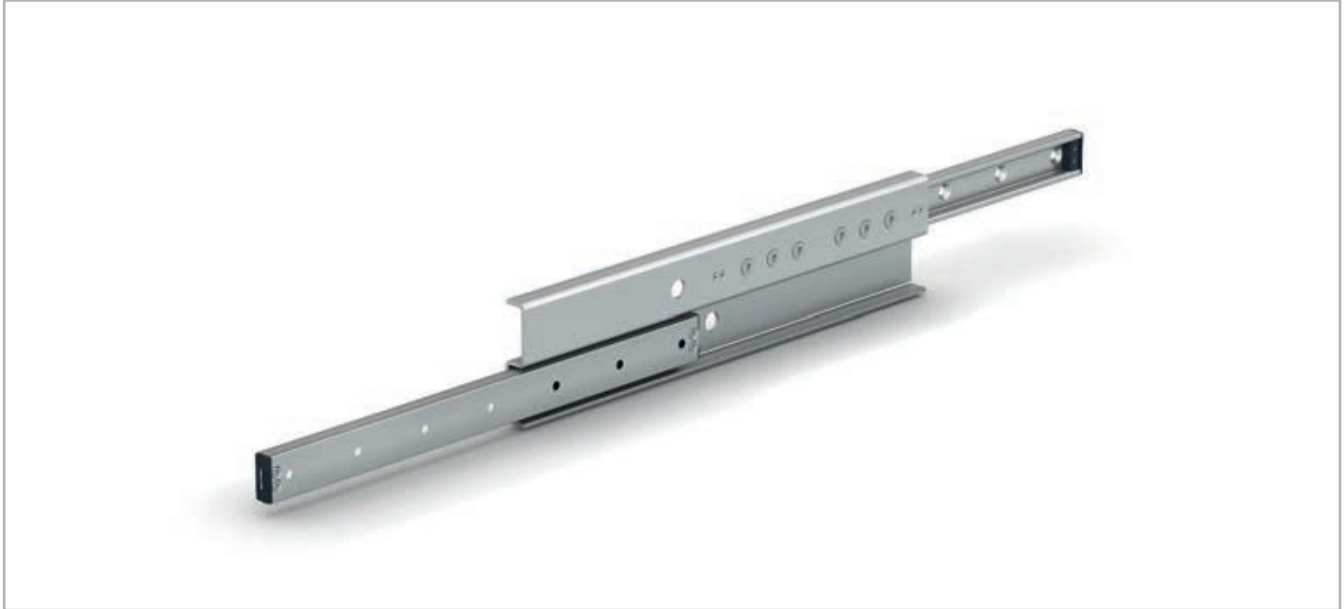

Fig. 1

Telerace family is composed of telescopic rails with ball bearings. These rolling elements make the product less sensitive to high dynamics or shifting working cycles that are typical for automation. Telerace rails are therefore ideal for automated applications where high number of cycles, long service requirements and low maintenance are essentials. In addition, the absence of the ball cage contributes to make Telerace the ideal choice for vertical or variable stroke applications and whenever the rail must function in presence of dirt and debris.

The rails come in six series. It is possible to choose between double row and single row ball bearings, different geometries, sizes and materials to perfectly fit the project and improve the productivity to various kinds of telescopic applications. Each series is designed and equipped to meet specific requirements not only in terms of loads, lifetime and environment but also regarding project simplification and modularity of the solution.

The listed load capacities are per pair of rails, with the load centered. In case the load is not centered, the load capacity is reduced.

The most important characteristics:

- Compensation of minor misalignment errors (TLR...AP)
- Customizable stroke/load capacity ratio (TLQ...P, TQN...P, TQAX).
- Ideal in dirty environments due to large rolling elements
- Ideal for automated applications, vertical and variable stroke
- Different anticorrosion treatments available
- High load capacity
- High operating speeds
- Wide temperature range

Preferred areas of application:

- Automation
- Material handling
- Industrial machines
- Medical technology
- Packaging machines
- Construction and machine technology (doors, protective covers)
- Robots and manipulators

TLR...P PLUS

Fully extending telescopic rails with double row ball bearings and rigid S-shaped intermediate element. They feature high load capacity, low deflection in extended state and a smooth motion without clearance. A special self-aligning version is available for compensating minor misalignments of the structure. Size 18 is hardened with Rollon-Nox nitriding and oxidation process that provides it with a fine black color. Size 28 and 43 have induction hardened and fine ground raceways with different anticorrosion treatments available.

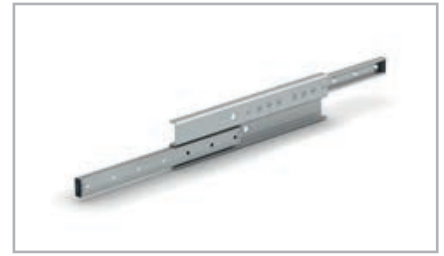

Fig. 2

TLQ...P PLUS

Telescopic rails with double row ball bearings and compact square cross-section. This combination allows high axial and radial load capacity with low overall dimensions and weight, making them particularly suitable for vertical applications. It is possible to customize the stroke/load capacity ratio by adjusting the distance between the sliders in the rail.

Size 18 is hardened with Rollon-Nox nitriding and oxidation process that provides it with a fine black color. Size 28 and 43 have induction hardened and fine ground raceways with different anticorrosion treatments available.



Fig. 3

TLN...P

Fully extending telescopic rails with single row ball bearings and rigid S-shaped intermediate element. They are designed to achieve smooth movement, high load capacity and low deflection while maintaining a cost-effective structure.

They are hardened with Rollon-Nox nitriding and black oxidation process.



Fig. 4

TQN...P

Telescopic rails with single row ball bearings and compact square cross section. They are particularly suitable for vertical applications and designed to achieve smooth movement, high load capacity and low deflection while maintaining a cost-effective structure. It is possible to customize the stroke/load capacity ratio by adjusting the distance between the sliders in the rail.

They are hardened with Rollon-Nox nitriding and black oxidation process.



Fig. 5

TLAX

Telescopic rails made of stainless steel AISI 304 with AISI 440 hardened steel rollers with 2RS seals and lubricated for life with grease for longevity and low temperature applications. They are ideal for pharmaceutical, chemical, medical industries or marine environment. For very severe environmental conditions, they can be supplied in electro-polished version for a further improved corrosion resistance.



Fig. 6

TQAX

Compact telescopic rails made of stainless steel AISI 304 with AISI 440 hardened steel rollers with 2RS seals and lubricated for life with grease for longevity and low temperature applications. They are particularly suitable for vertical applications and pharmaceutical, chemical, medical industries or marine environment. It is possible to customize the stroke/load capacity ratio by adjusting the distance between the sliders in the rail. For very severe environmental conditions, they can be supplied in electro-polished version for a further improved corrosion resistance.



Fig. 7

Rollers

TLR...P and TLQ...P telescopic rails feature double row ball bearings to provide high load capacities in both radial and axial direction and are equipped with splash-proof plastic seal (2RS). The rollers have two contact points on each raceway, creating a well constrained movement in both radial and axial direction. The self-aligning version TLR...AP features a combination of guiding and floating rollers. The floating rollers are constrained radially but allowed to float in the axial direction between the two shoulders and to rotate a little.



Fig. 8

TLN...P, TLQ...P, TLAX and TQAX telescopic rails feature single row ball bearings made of hardened steel or stainless steel and lubricated for life.



Fig. 9

Overview product cross sections



> TLR...P-TLQ...P series **PLUS**

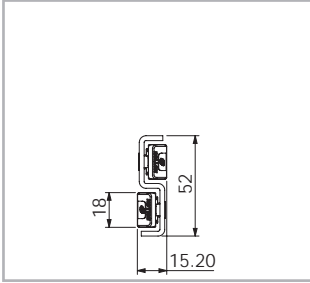

Fig. 10

TLR18P..R - TLR18P..L
Load capacity p. TL-8

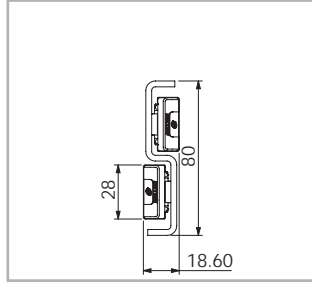

Fig. 11

TLR28P..R - TLR28P..L
Load capacity p. TL-8

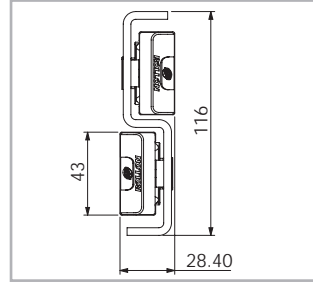

Fig. 12

TLR43P..R - TLR43P..L
Load capacity p. TL-9

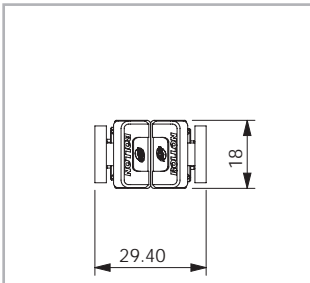

Fig. 13

TLQ18P..
Load capacity p. TL-10

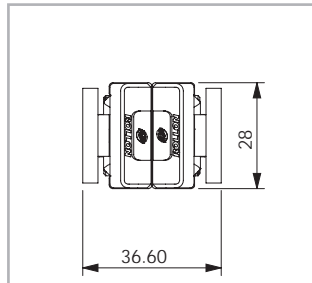

Fig. 14

TLQ28P..
Load capacity p. TL-10

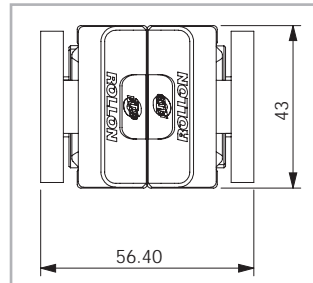

Fig. 15

TLQ43P..
Load capacity p. TL-11

> TLN...P - TQN...P series

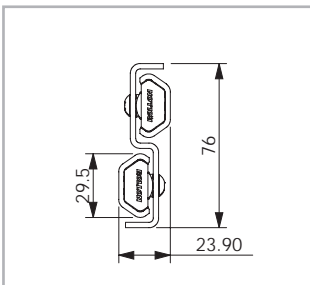

Fig. 16

TLN30P..R - TLN30P..L
Load capacity p. TL-12

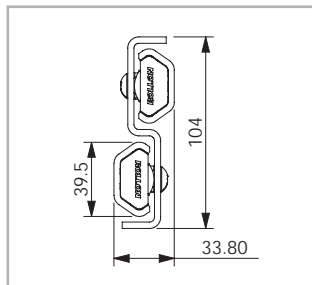

Fig. 17

TLN40P..R - TLN40P..L
Load capacity p. TL-13

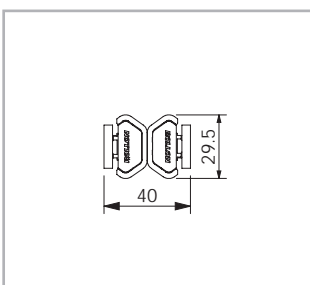

Fig. 18

TQN30P..
Load capacity p. TL-14

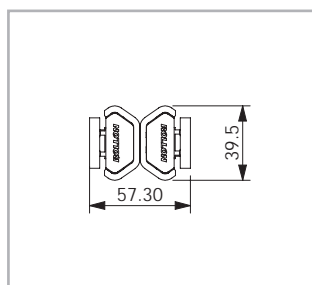

Fig. 19

TQN40P..
Load capacity p. TL-15

T
L

> **TLAX-TQAX series**

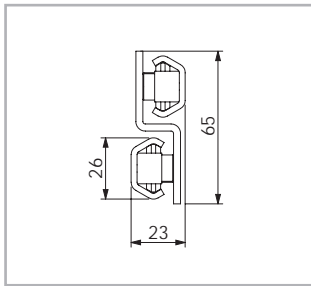

Fig. 20

TLAX26...
Load capacity p. TL-16

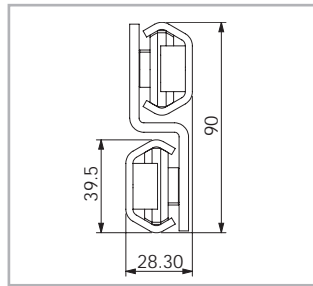

Fig. 21

TLAX40...
Load capacity p. TL-17

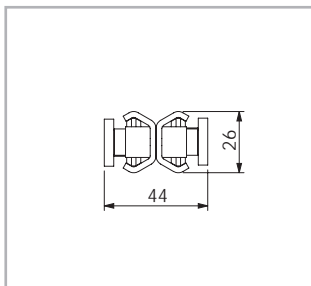

Fig. 22

TQAX26...
Load capacity p. TL-18

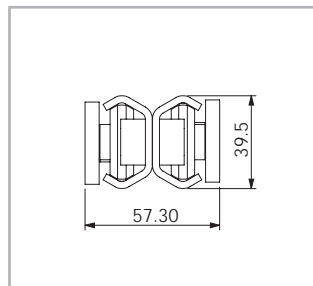

Fig. 23

TQAX40...
Load capacity p. TL-19

Technical data

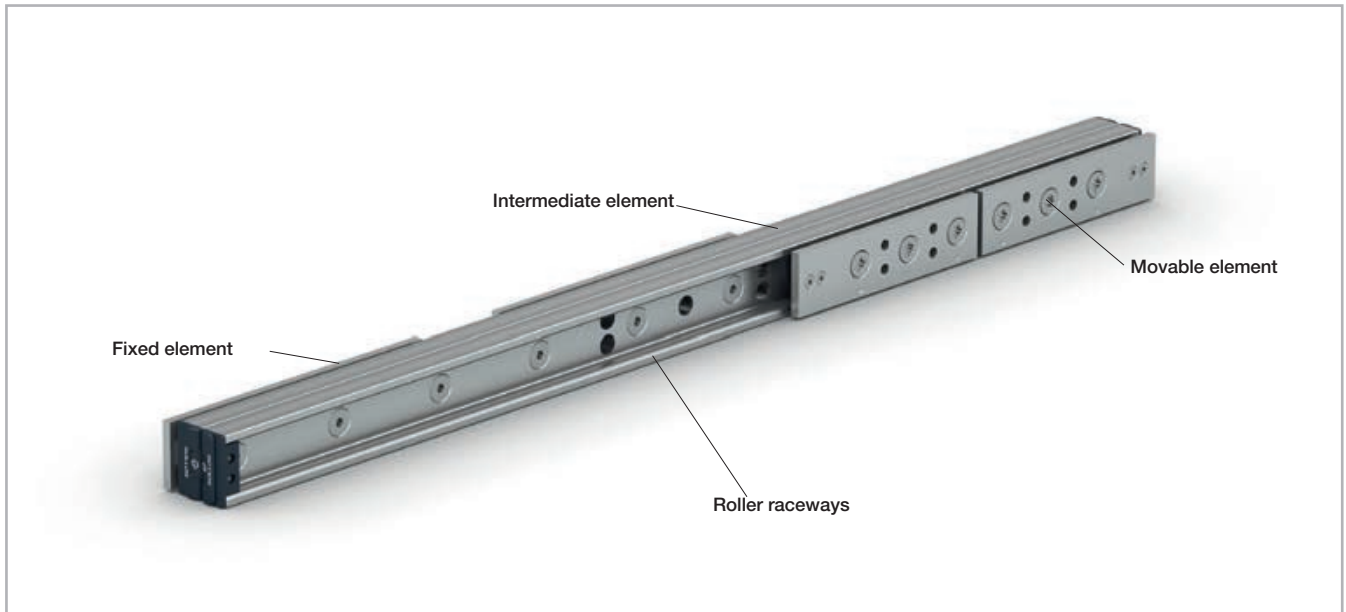

Fig. 24

Performance characteristics:

TLR...P and TLQ...P

- Available sizes: 18, 28, 43
- Max. operating speed: 1 m/s (depending on application and stroke)
- Max. operating temperature: -20° C to + 110° C (-4° F to 230° F).
- Rail material: cold-drawn carbon steel CF53 (size 28-43), cold-drawn carbon steel 20MnCr5 (size 18) Fe P02G for intermediate element.
- Surface treatment: zinc-plated ISO 2081 with induction hardened and ground raceways (size 28-43), hardened with Rollon-Nox treatment (size 18)
- Rollers material: steel 100Cr6 (also available stainless steel AISI 440)
- Roller seal/shield: 2RS (splash-proof)

TLN...P and TQN...P

- Available sizes: 30, 40
- Max. operating speed: 1 m/s (depending on application and stroke)
- Max. operating temperature: -20° C to + 80° C (-4° F to 176° F)
- Rail material: S420MC for rails, Fe P02 for TLN...P intermediate element, S235JRG2 for TLQ...P sliders
- Surface treatment: hardened with Rollon-Nox process
- Rollers material: carbon steel with 2Z shield (dust cover seal)

TLAX and TQAX

- Available sizes: 26,40
- Max. operating speed: 1 m/s (depending on application and stroke)
- Max. operating temperature: -20 °C to +80 °C (-4° F to 176° F)
- Rail material: stainless steel AISI 304
- Rollers material: stainless steel AISI 440 with 2RS shield (splashproof seal)

Remarks

- All load capacity data are based on a pair of telescopic rails, except the value Mx of TLQ...P, TQN...P and TQAX series.
- All load capacity data is based on continuous operation
- Internal stops are used to stop the unloaded slider and the rollers. Please use external stops as end stops for a loaded system
- TLR...P, TLN...P and TLAX must be mounted with upper rail fixed to structure and the lower rail fixed to the moving part.
- Custom strokes on request.
- For TLR...P, TLN...P series please observe right or left side use.
- Fixing screws of property class 10.9 must be used for all telescopic rails.

Dimensions and load capacity



➤ TLR...P **PLUS**

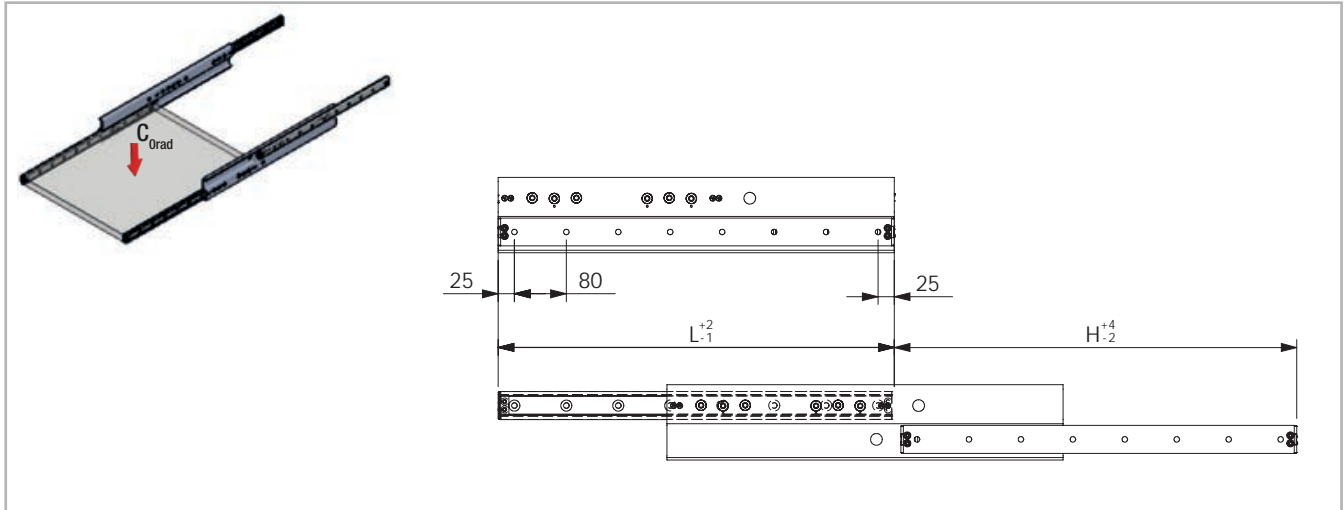

Fig. 25

Type	Size	Length L [mm]	Stroke H [mm]	Load capacity for a pair of rails		N° of holes	Weight [Kg]
				Dynamic load coefficient C [N]	C _{Orad} [N]		
TLR...P	18	290	290	1510	732	4	0.9
		370	370	2001	970	5	1.2
		450	450	2291	1111	6	1.4
		530	530	2485	1205	7	1.6
		610	610	2623	1272	8	1.9
		690	690	2727	1322	9	2.1
	28	770	770	2808	1361	10	2.3
		370	380	1288	695	5	2.1
		450	460	3401	1835	6	2.5
		530	540	3893	2101	7	2.9
		610	620	5490	2963	8	3.3
		690	700	5981	3227	9	3.7
		770	780	6215	3354	10	4.1
		850	860	6403	3455	11	4.5
		930	940	6556	3267	12	4.9
		1010	1020	6684	3041	13	5.3
		1090	1100	6792	2844	14	5.7
		1170	1180	6885	2672	15	6.1
		1250	1260	6965	2519	16	6.5
1330	1340	7035	2382	17	6.9		
1410	1420	7097	2260	18	7.3		
1490	1500	7152	2149	19	7.7		

Tab. 1

Type	Size	Length L [mm]	Stroke H [mm]	Load capacity for a pair of rails		N° of holes	Weight [Kg]
				Dynamic load coefficient C [N]	C _{Orad} [N]		
TLR...P	43	530	540	3891	2205	7	6.4
		610	620	7501	4251	8	7.3
		690	700	9725	4805	9	8.2
		770	780	10497	5949	10	9.1
		850	860	13428	7256	11	10.0
		930	940	14266	8085	12	10.9
		1010	1020	14691	8326	13	11.8
		1090	1100	15050	8040	14	12.7
		1170	1180	15356	7568	15	13.6
		1250	1260	15621	7148	16	14.5
		1330	1340	15852	6773	17	15.4
		1410	1420	16055	6435	18	16.3
		1490	1500	16235	6129	19	17.2
		1570	1580	16397	5851	20	18.1
		1650	1660	16541	5597	21	19.0
		1730	1740	16672	5364	22	19.9
		1810	1820	16791	5150	23	20.8
		1890	1900	16899	4952	24	21.7
1970	1980	16998	4769	25	22.6		

Tab. 2

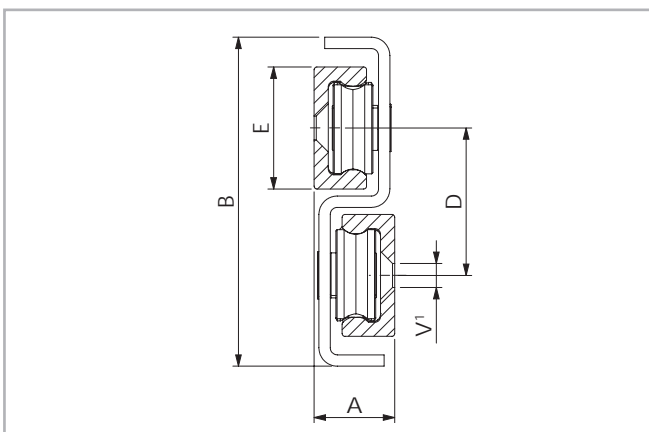

¹ Fixing holes (V) for countersunk head screw according to DIN 7991

Fig. 26

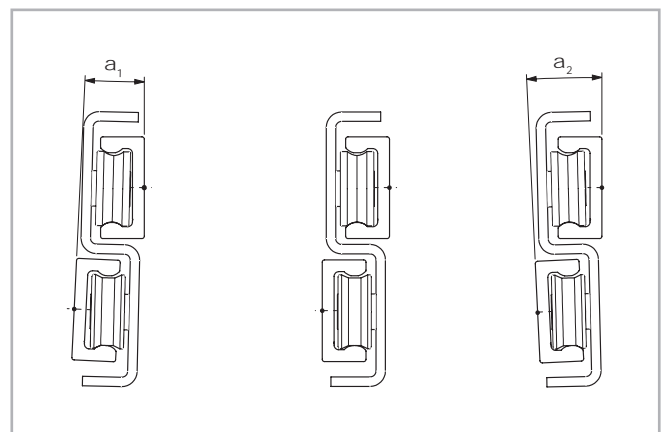

TLR..AP Self-aligning version available for all sizes (see pg. TL-27)

Fig. 27

Type	Size	A [mm]	B [mm]	E [mm]	D [mm]	V
TLR...P	18	15.2	52	18	25	M4
TLR..AP	28	18.6	80	28	35	M5
	43	28.4	116	43	52	M8

Rails are available in left and right version:
TLR...P...L left version
TLR...P...R right version

Tab. 3

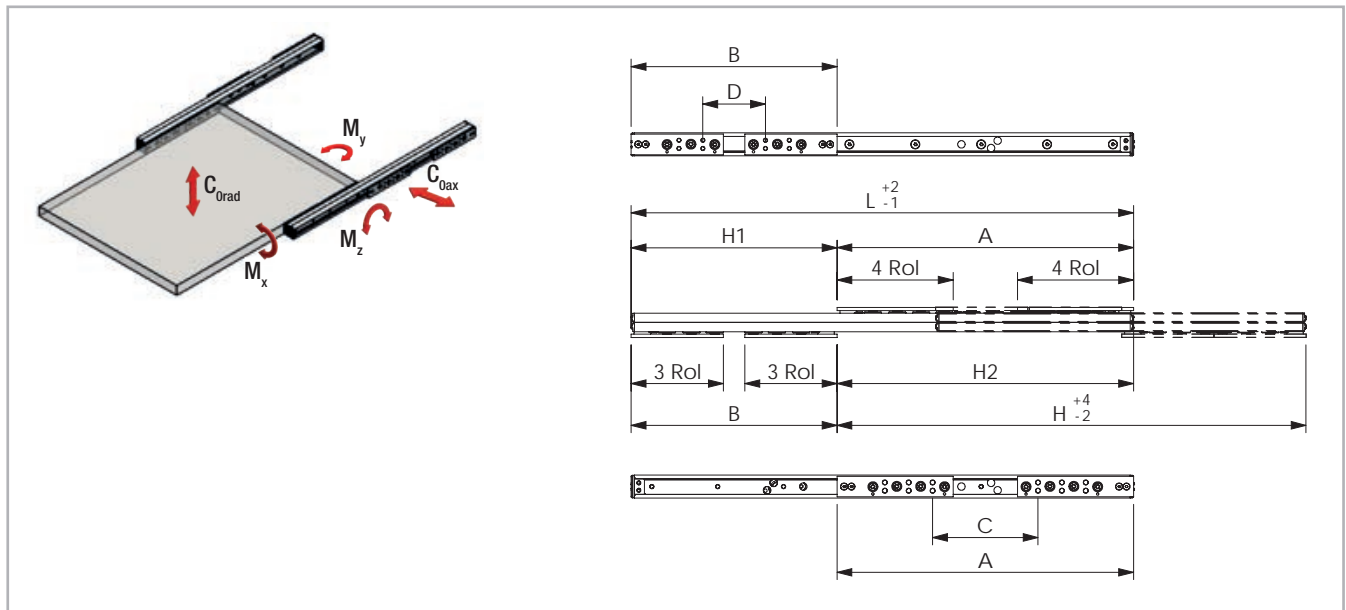

Fig. 28

Type	Size	L [mm]	H [mm]	Fixed sliders*3			Mobile sliders*2			Load capacity and moments for a pair of rails					
				A [mm]	C [mm]	H1 [mm]	B [mm]	D [mm]	H2 [mm]	Dynamic load coefficient C [N]	C _{Orad} [N]	C _{Oax} [N]	M _x *1 [Nm]	M _y [Nm]	M _z [Nm]
TLQ...P	18	370	370	185	47	185	185	47	185	1009	447	282	6	88	110
		450	450	270	132	180	180	42	270	1619	863	379	6	81	102
		530	530	318	180	212	212	74	318	1770	771	332	6	107	153
		610	610	366	228	244	244	106	366	1878	687	296	6	107	204
		690	690	414	276	276	276	138	414	1959	618	266	6	107	250
		770	770	462	324	308	308	170	462	2021	563	242	6	107	250
	28	450	450	227	53	223	223	49	227	1794	882	519	18	187	250
		530	530	307	133	223	223	49	307	2693	1536	778	18	187	250
		610	610	360	128	250	250	76	360	2799	2146	820	18	238	317
		690	690	408	176	282	282	108	408	3030	1940	742	18	310	419
		770	770	456	224	314	314	140	456	3207	1770	677	18	310	522
		850	850	504	272	346	346	172	504	3347	1628	622	18	310	624
		930	930	552	320	378	378	204	552	3460	1507	576	18	310	726
		1010	1010	600	368	410	410	236	600	3553	1403	536	18	310	810
		1090	1090	648	416	442	442	268	648	3631	1312	501	18	310	810
		1170	1170	696	464	474	474	300	696	3698	1232	471	18	310	810
		1250	1250	744	512	506	506	332	744	3755	1161	444	18	310	810
		1330	1330	792	560	538	538	364	792	3805	1098	420	18	310	810
1410	1410	840	608	570	570	396	840	3849	1042	398	18	310	810		
1490	1490	888	656	602	602	428	888	3888	991	379	18	310	810		

*1 The value M_x refers to a single rail

*2 All mobile sliders are 3 rollers type

*3 For size 18 all fixed sliders are 3 rollers type. For size 28 lengths 450-530mm fixed sliders are 3 rollers type, for longer lengths are 4 rollers type

Tab. 4

Type	Size	L [mm]	H [mm]	Fixed sliders*3			Mobile sliders*2			Load capacity and moments for a pair of rails					
				A [mm]	C [mm]	H1 [mm]	B [mm]	D [mm]	H2 [mm]	Dynamic load coefficient C [N]	C _{0rad} [N]	C _{0ax} [N]	M _x *1 [Nm]	M _y [Nm]	M _z [Nm]
TLQ...P	43	610	600	310	78	300	310	78	300	2841	2300	1829	64	690	920
		690	690	374	142	316	316	84	374	4132	3345	2359	64	1044	1008
		770	770	456	140	314	314	82	456	6218	5034	2084	64	1044	944
		850	850	504	188	346	346	114	504	6708	5357	1930	64	1044	1200
		930	930	552	236	378	378	146	552	7103	4988	1797	64	1044	1456
		1010	1010	600	284	410	410	178	600	7428	4667	1681	64	1044	1712
		1090	1090	648	332	442	442	210	648	7701	4384	1579	64	1044	1968
		1170	1170	696	380	474	474	242	696	7932	4134	1489	64	1044	2224
		1250	1250	744	428	506	506	274	744	8131	3911	1409	64	1044	2480
		1330	1330	792	476	538	538	306	792	8304	3711	1337	64	1044	2736
		1410	1410	840	524	570	570	338	840	8456	3530	1272	64	1044	2898
		1490	1490	888	572	602	602	370	888	8590	3366	1213	64	1044	2898
		1570	1570	936	620	634	634	402	936	8710	3216	1159	64	1044	2898
		1650	1650	984	668	666	666	434	984	8817	3080	1109	64	1044	2898
		1730	1730	1032	716	698	698	466	1032	8914	2954	1064	64	1044	2898
		1810	1810	1080	764	730	730	498	1080	9001	2838	1023	64	1044	2898
		1890	1890	1128	812	762	762	530	1128	9081	2731	984	64	1044	2898
1970	1970	1176	860	794	794	562	1176	9154	2632	948	64	1044	2898		

*1 The value Mx refers to a single rail

*2 All mobile sliders are 3 rollers type

*3 For lengths 610-690mm fixed sliders are 3 rollers type, for longer lengths are 4 rollers type

Tab. 5

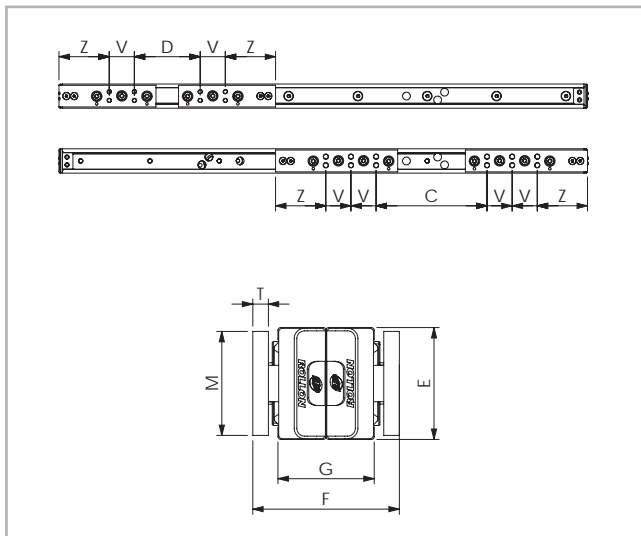
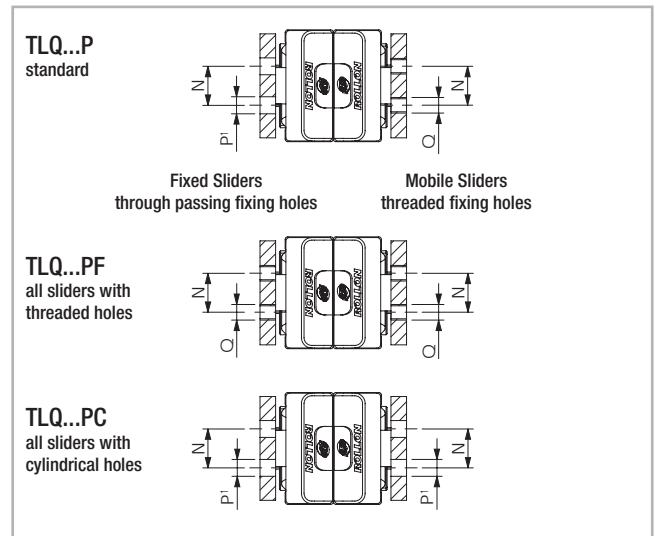

Fig. 29



*1 Fixing holes (P) for fixing screw according to DIN 912.

Fig. 30

Type	Size	E [mm]	F [mm]	G [mm]	M [mm]	T [mm]	N [mm]	P [mm]	Q	Sliders		Z [mm]	V [mm]	Weight [kg/m]	Weight 4 sliders [Kg]
										Num. of rollers	Length [mm]				
TLQ...P	18	18	29.4	19	15	3	8	-	M4	3	87	48	21	1.4	0.4
	28	28	36.6	22.6	25	4	10	Ø5.5	M5	3	112	58	29	2.5	1.5
										4	141				
43	43	56.4	37	40	6	15	Ø6.5	M6	3	155	74	42	6	2.4	
									4	197					

Three options for fixing holes available (see fig. 30). Rail size 18 is only available in F version with all threaded holes.

When used in pairs, the same rail can be installed left or right just by rotating it. See "Installation Instructions" on pg. TL-29.

Tab. 6

> TLN...P

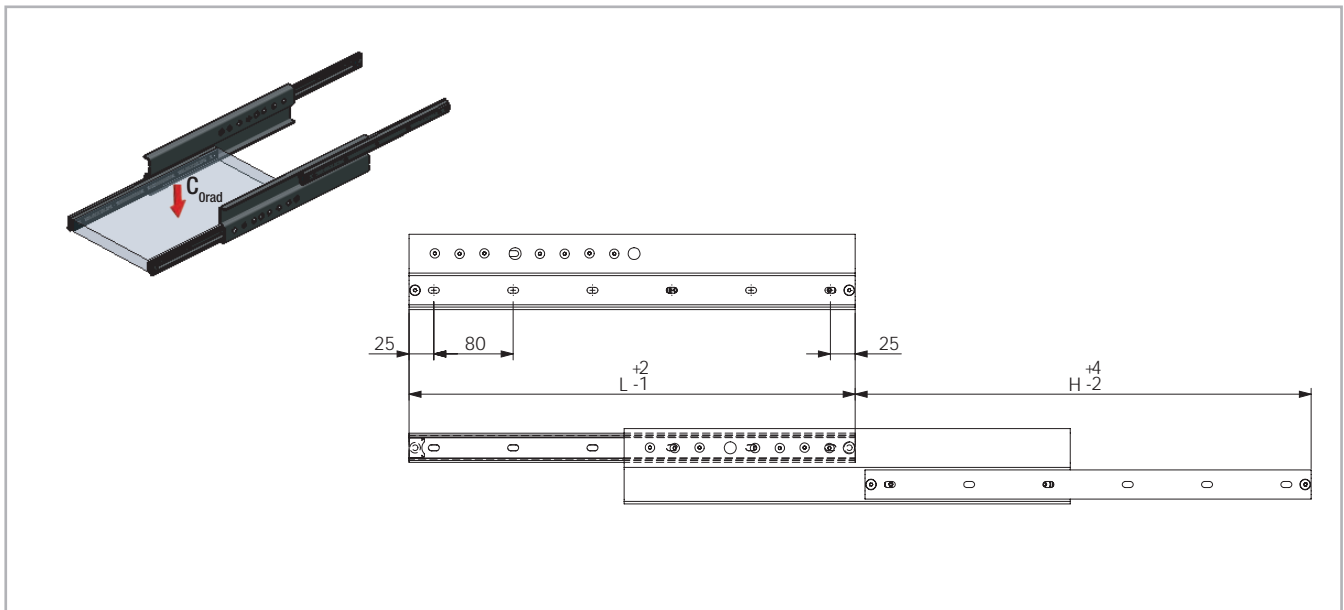

Fig. 31

Type	Size	Length L [mm]	Stroke H [mm]	Load capacity for a pair of rails		N° of holes	Weight [Kg]
				Dynamic load coefficient C [N]	C _{Orad} [N]		
TLN...P	30	450	460	1287	1843	6	1.9
		530	540	1421	2090	7	2.2
		610	620	1517	2231	8	2.5
		690	700	1589	2337	9	2.8
		770	780	1645	2420	10	3.1
		850	860	1690	2486	11	3.4
		930	940	1727	2540	12	3.7
		1010	1020	1758	2439	13	4.0
		1090	1100	1784	2278	14	4.3
		1170	1180	1807	2137	15	4.6
		1250	1260	1826	2013	16	4.9
		1330	1340	1843	1902	17	5.2
		1410	1420	1858	1802	18	5.6
1490	1500	1871	1713	19	5.9		

Tab. 7

Type	Size	Length L [mm]	Stroke H [mm]	Load capacity for a pair of rails		N° of holes	Weight [Kg]
				Dynamic load coefficient C [N]	C _{0rad} [N]		
TLN...P	40	610	620	2549	3633	8	5.1
		690	700	2754	4050	9	5.7
		770	780	2913	4284	10	6.3
		850	860	3040	4470	11	6.9
		930	940	3143	4622	12	7.5
		1010	1020	3229	4748	13	8.1
		1090	1100	3301	4855	14	8.7
		1170	1180	3363	4946	15	9.2
		1250	1260	3417	5025	16	9.8
		1330	1340	3464	5094	17	10.4
		1410	1420	3505	4936	18	11.0
		1490	1500	3542	4696	19	11.6
		1570	1580	3575	4478	20	12.2
		1650	1660	3604	4280	21	12.8
		1730	1740	3631	4098	22	13.4
		1810	1820	3655	3932	23	14.0
		1890	1900	3677	3778	24	14.6
1970	1980	3698	3636	25	15.2		

Tab. 8

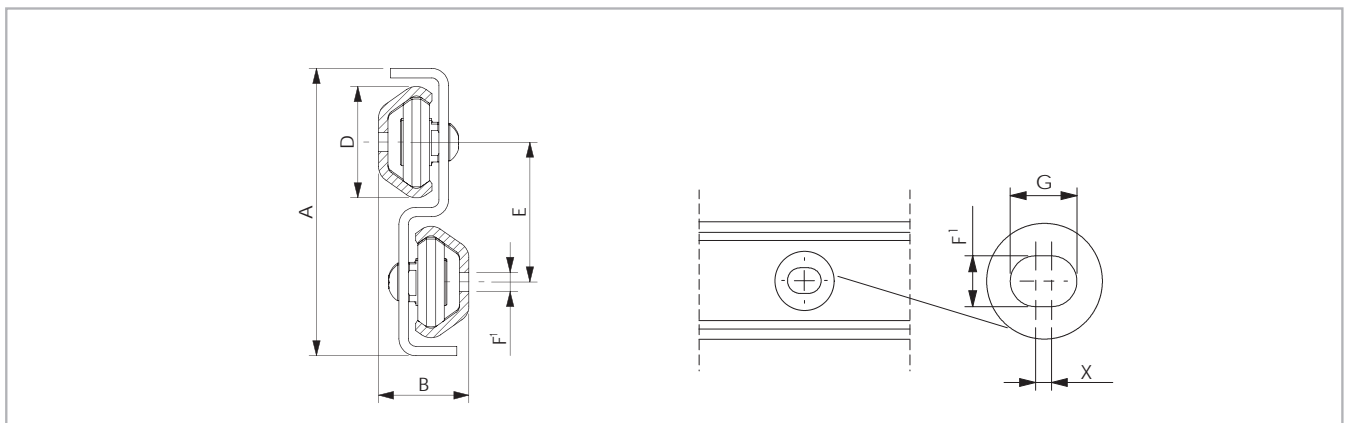

¹ Fixing holes (F) are through passing holes for standard button-head screws ISO 7380. Alternatively, very flat-head Rollon Torx screws can be used.

Fig. 32

Type	Size	A [mm]	B [mm]	D [mm]	E [mm]	F [mm]	G [mm]	X [mm]	Fixing screw
TLN...P	30	76	23.9	29.5	37	6	11	5	M5 ISO7380
	40	104	33.8	39.5	50	9	13	4	M8 ISO7380

Rails are available in left and right version:
 TLN...P...L left version
 TLN...P...R right version

Tab. 9

> TQN...P

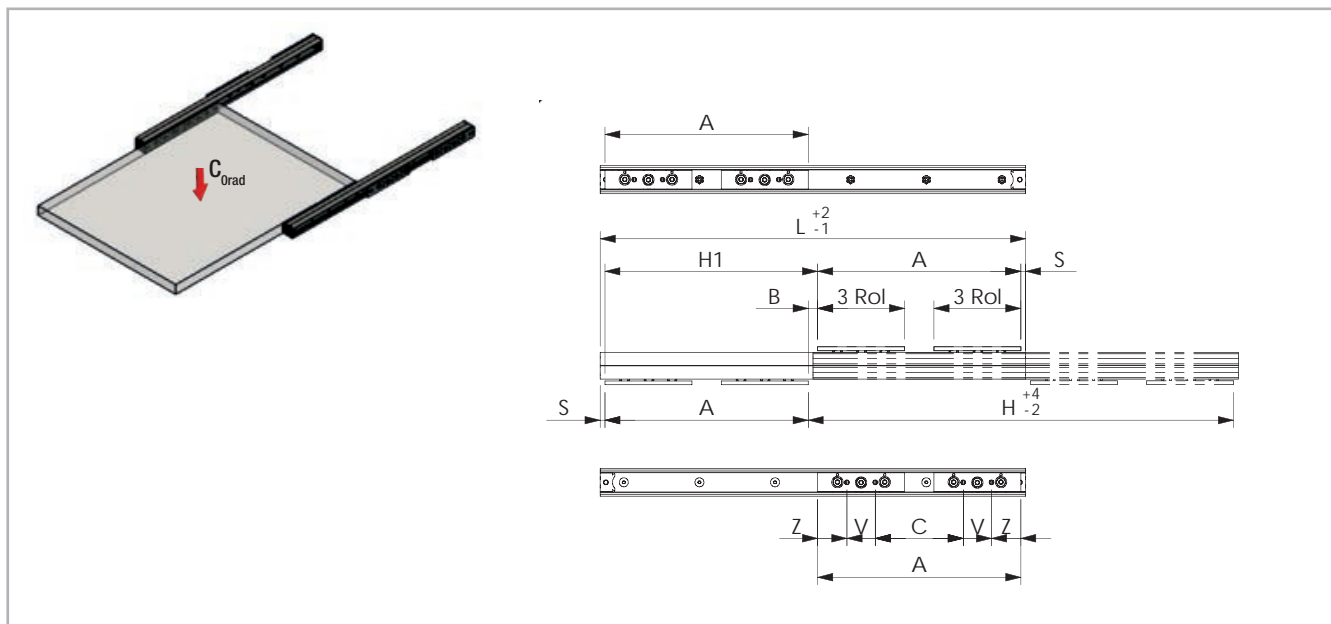

Fig. 33

Type	Size	L [mm]	H [mm]	Fixed & Mobile sliders*2			Load capacity and moments for a pair of rails					
				A [mm]	C [mm]	H1 [mm]	Dynamic load coefficient C [N]	C _{Orad} [N]	C _{Oax} [N]	M _x * [Nm]	M _y [Nm]	M _z [Nm]
TQN...P	30	450	450	215	93	225	606	891	371	8	174	246
		530	530	255	133	265	702	1032	430	8	228	326
		610	610	295	173	305	776	1140	472	8	228	406
		690	690	335	213	345	835	1190	503	8	228	472
		770	770	375	253	385	883	1081	521	8	228	472
		850	850	415	293	425	923	990	477	8	228	472
		930	930	455	333	465	957	913	440	8	228	472
		1010	1010	495	373	505	986	847	409	8	228	472
		1090	1090	535	413	545	1011	790	381	8	228	472
		1170	1170	575	453	585	1033	741	357	8	228	472
		1250	1250	615	493	625	1052	697	336	8	228	472
		1330	1330	655	533	665	1069	658	317	8	228	472
		1410	1410	695	573	705	1085	623	300	8	228	472
1490	1490	735	613	745	1099	592	285	8	228	472		

* The value M_x refers to a single rail
 *2 All sliders are 3 rollers type

Tab. 10

Type	Size	L [mm]	H [mm]	Fixed & Mobile sliders*2			Load capacity and moments for a pair of rails					
				A [mm]	C [mm]	H1 [mm]	Dynamic load coefficient C [N]	C _{0rad} [N]	C _{0ax} [N]	M _x * [Nm]	M _y [Nm]	M _z [Nm]
TQN...P	40	610	610	295	40	305	1619	1695	1220	20	562	640
		690	690	335	80	345	1762	1916	1327	20	562	800
		770	770	375	120	385	1872	2098	1228	20	562	960
		850	850	415	160	425	1959	2251	1129	20	562	1120
		930	930	455	200	465	2030	2142	1045	20	562	1152
		1010	1010	495	240	505	2089	1994	972	20	562	1152
		1090	1090	535	280	545	2139	1864	909	20	562	1152
		1170	1170	575	320	585	2181	1751	854	20	562	1152
		1250	1250	615	360	625	2218	1651	805	20	562	1152
		1330	1330	655	400	665	2250	1561	761	20	562	1152
		1410	1410	695	440	705	2278	1481	722	20	562	1152
		1490	1490	735	480	745	2303	1408	687	20	562	1152
		1570	1570	775	520	785	2325	1343	655	20	562	1152
		1650	1650	815	560	825	2345	1283	626	20	562	1152
		1730	1730	855	600	865	2363	1228	599	20	562	1152
		1810	1810	895	640	905	2380	1178	575	20	562	1152
		1890	1890	935	680	945	2394	1131	552	20	562	1152
		1970	1970	975	720	985	2408	1089	531	20	562	1152

* The value Mx refers to a single rail
 ** All sliders are 3 rollers type

Tab. 11

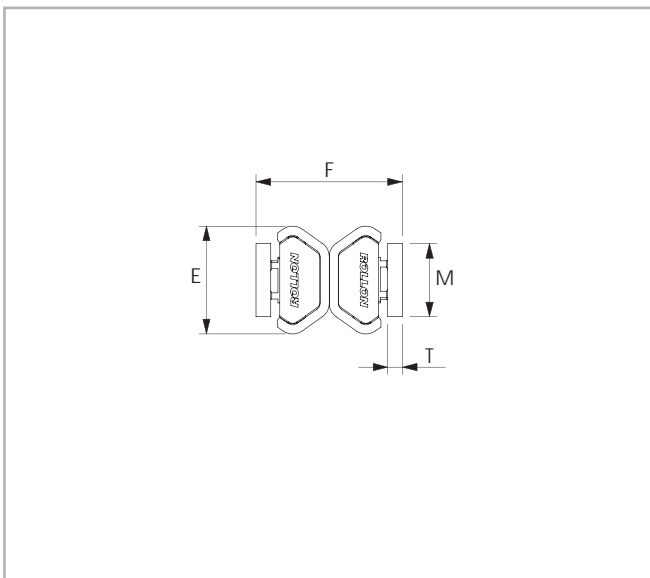

Fig. 34

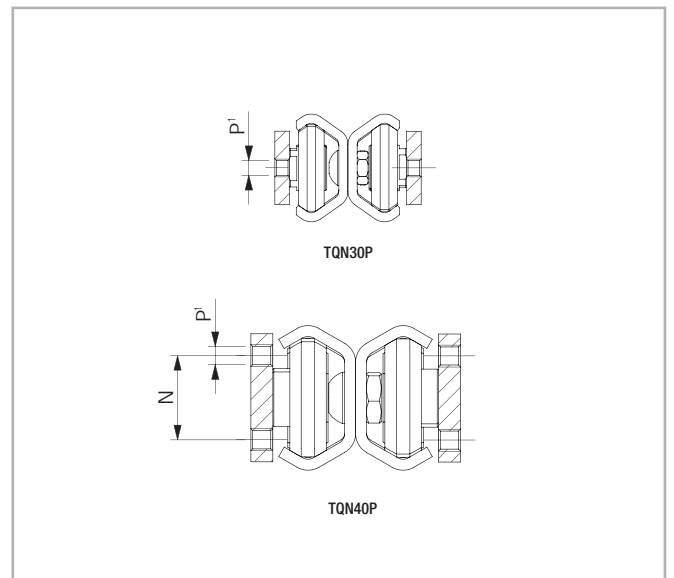

Fig. 35

¹ Fixing holes (P) are threaded holes.

Type	Size	E [mm]	F [mm]	M [mm]	T [mm]	N [mm]	P	Sliders		Z [mm]	V [mm]	S [mm]	Num. of holes	B [mm]	Rail Weight [kg/m]	Weight 4 sliders [Kg]
								Num. of rollers	Length [mm]							
TQN...P	30	29.5	40	20	4	-	M5	3	92	31	30	5	2	10	1.9	0.45
	40	39.5	57.3	35	6	23	M6	3	135	7.5	120	5	4	10	3.1	1.5

When used in pair, the same rail can be installed left or right just by rotating it. See "Installation Instructions" on pg. TL-29.

Tab. 12

> TLAX

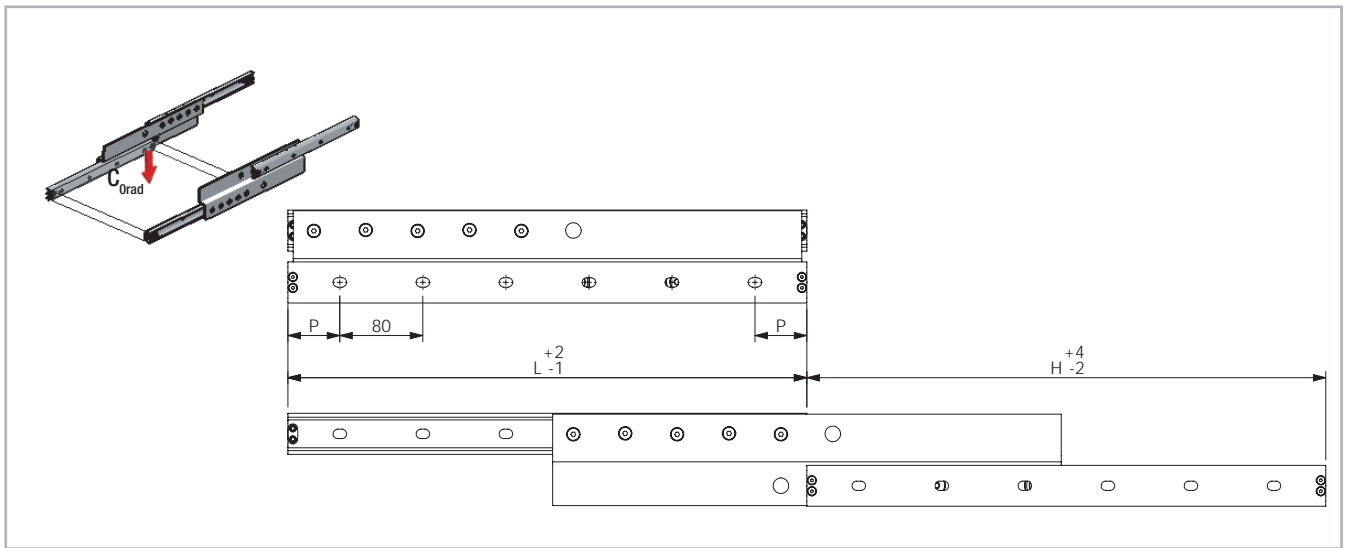

Fig. 36

Type	Size	Length L [mm]	Stroke H [mm]	P [mm]	N° of access holes	Load capacity for a pair of rails C_{Orad} [N]	Weight [kg]
TLAX	26	300	300	30	4	466	1.2
		350	350	55	4	621	1.4
		400	400	40	5	745	1.5
		450	450	25	6	846	1.7
		500	500	50	6	931	1.9
		550	550	35	7	1003	2.1
		600	600	20	8	1064	2.3
		650	650	45	8	1117	2.4
		700	700	30	9	1164	2.6
		750	750	55	9	1205	2.8
		800	800	40	10	1241	3.0
		850	850	25	11	1274	3.2
		900	900	50	11	1303	3.3
		1000	1000	20	13	1329	3.7
1100	1100	30	14	1218	4.1		
1200	1200	40	15	1125	4.4		

Tab. 13

Type	Size	Length L [mm]	Stroke H [mm]	P [mm]	N° of access holes	Load capacity for a pair of rails C_{Orad} [N]	Weight [kg]
TLAX	40	500	500	50	6	985	3.4
		550	550	35	7	1143	3.7
		600	600	20	8	1280	4.1
		650	650	45	8	1400	4.4
		700	700	30	9	1506	4.7
		750	750	55	9	1600	5
		800	800	40	10	1684	5.3
		850	850	25	11	1760	5.7
		900	900	50	11	1829	6
		1000	1000	20	13	1948	6.6
		1100	1100	30	14	2048	7.3
		1200	1200	40	15	2133	7.9
		1300	1300	50	16	1990	8.5
		1400	1400	20	18	1862	9.2
		1500	1500	30	19	1749	9.8
1600	1600	40	20	1649	10.5		

Tab. 14

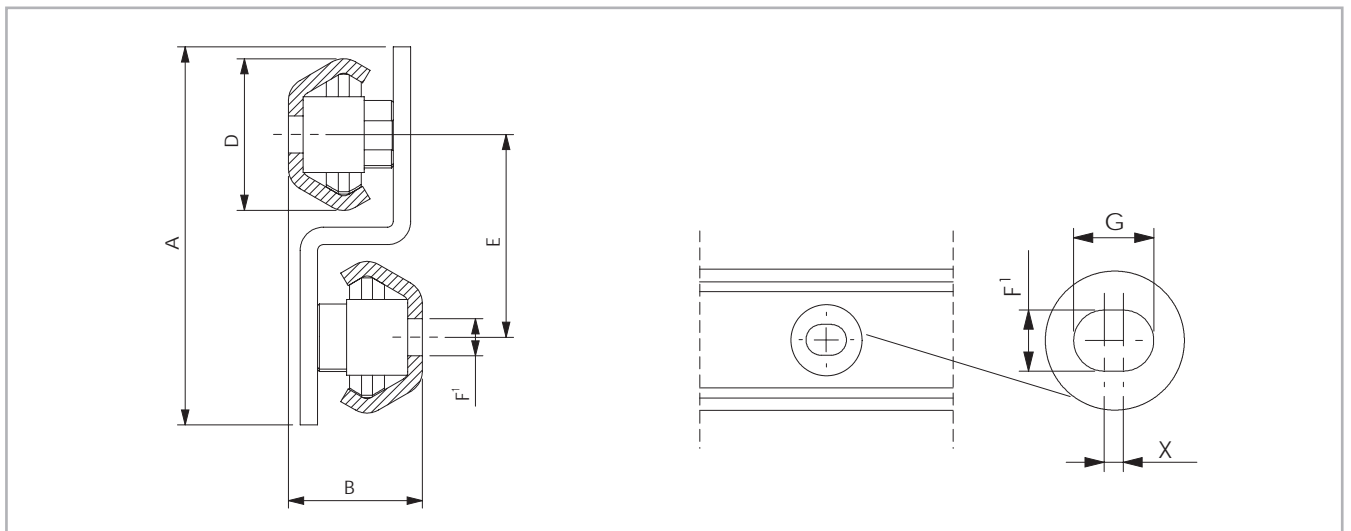

1 Fixing holes (F) are through passing holes for standard button-head screws ISO 7380. Alternatively, special low head Rollon Torx screws can be used.

Fig. 37

Type	Size	A [mm]	B [mm]	D [mm]	E [mm]	F [mm]	G [mm]	X [mm]	Type of Fixing screws
TLAX	26	65	23	26	35	6	11	5	M5 ISO7380
	40	90	28.3	39.5	50	9	13	4	M8 ISO7380

When used in pair, the same rail can be installed left or right just by rotating it.

Tab. 15

> TQAX

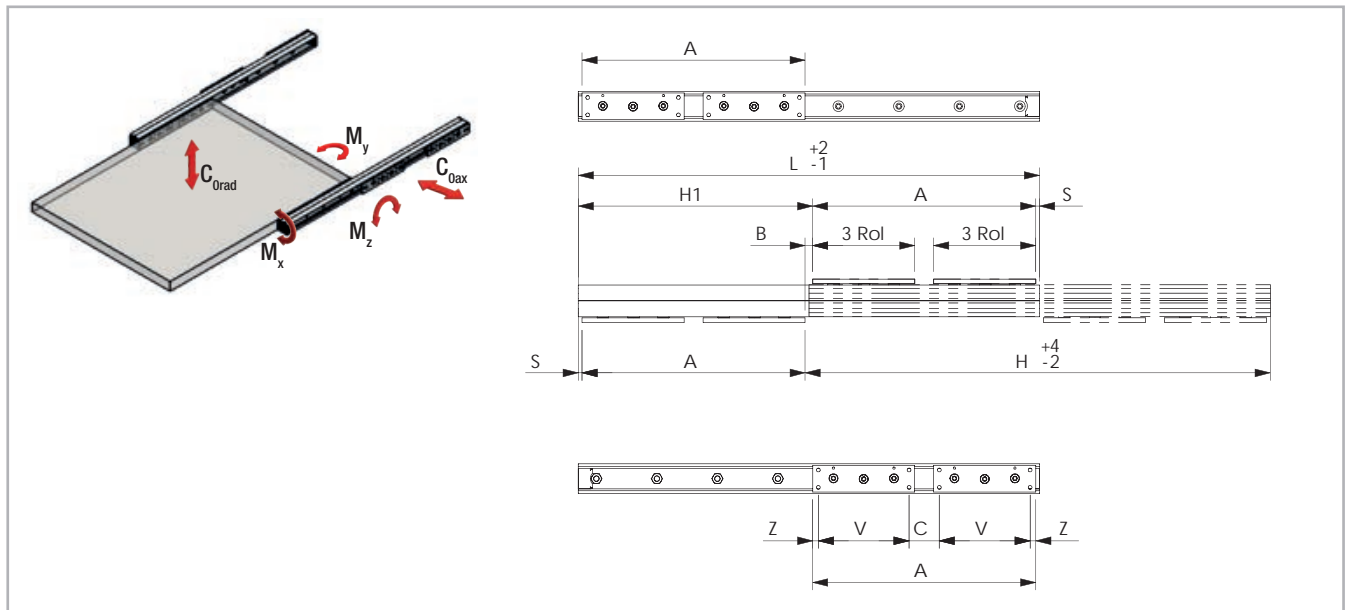

Fig. 38

Type	Size	L [mm]	H [mm]	Fixed & Mobile sliders*2			Load capacity and moments for a pair of rails				
				A [mm]	C [mm]	H1 [mm]	C _{Orad} [N]	C _{Oax} [N]	M _x * [Nm]	M _y [Nm]	M _z [Nm]
TQAX	26	400	400	172	62	200	580	287	6	99	147
		450	450	197	87	225	672	319	6	126	187
		500	500	222	112	250	748	344	6	153	227
		550	550	247	137	275	813	364	6	169	268
		600	600	272	162	300	869	380	6	169	308
		650	650	297	187	325	831	393	6	169	315
		700	700	322	212	350	779	405	6	169	315
		750	750	347	237	375	734	394	6	169	315
		800	800	372	262	400	694	372	6	169	315
		850	850	397	287	425	657	353	6	169	315
		900	900	422	312	450	625	335	6	169	315
		950	950	447	337	475	595	319	6	169	315
		1000	1000	472	362	500	568	305	6	169	315
		1100	1100	522	412	550	521	280	6	169	315
1200	1200	572	462	600	481	258	6	169	315		

* The value M_x refers to a single rail

*2 All sliders are 3 rollers type

Tab. 16

Type	Size	L [mm]	H [mm]	Fixed & Mobile sliders*2			Load capacity and moments for a pair of rails				
				A [mm]	C [mm]	H1 [mm]	C _{0rad} [N]	C _{0ax} [N]	M _x * [Nm]	M _y [Nm]	M _z [Nm]
TQAX	40	600	600	300	45	300	1433	688	18	366	527
		650	650	325	70	325	1545	724	18	422	606
		700	700	350	95	350	1644	755	18	468	766
		750	750	375	120	375	1731	781	18	468	766
		800	800	400	145	400	1809	803	18	468	846
		850	850	425	170	425	1880	823	18	468	926
		900	900	450	195	450	1854	840	18	468	959
		950	950	475	220	475	1768	855	18	468	959
		1000	1000	500	245	500	1691	825	18	468	959
		1100	1100	550	295	550	1554	758	18	468	959
		1200	1200	600	345	600	1437	701	18	468	959
		1300	1300	650	395	650	1337	652	18	468	959
		1400	1400	700	445	700	1250	610	18	468	959
		1500	1500	750	495	750	1174	572	18	468	959
		1600	1600	800	545	800	1106	539	18	468	959

* The value M_x refers to a single rail
 *2 All sliders are 3 rollers type

Tab. 17

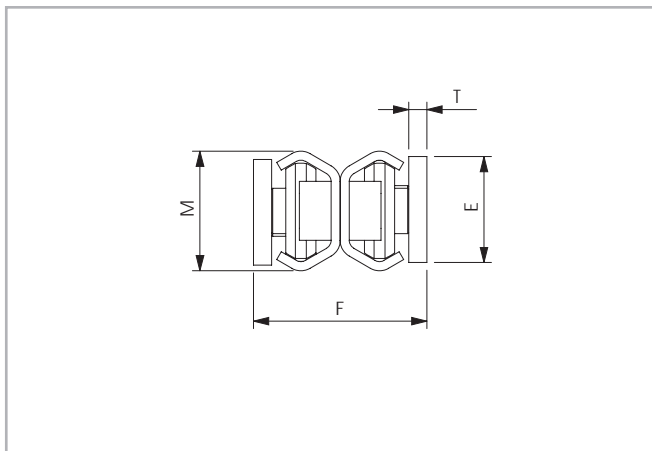
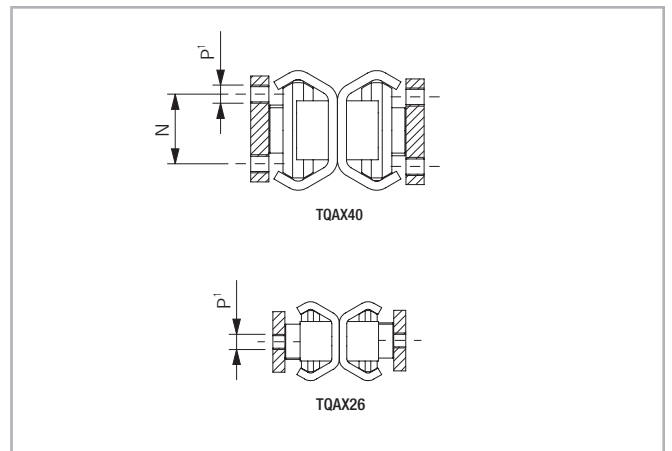

Fig. 39



1 Fixing holes (P) are threaded holes.

Fig. 40

Type	Size	E [mm]	F [mm]	M [mm]	T [mm]	N [mm]	P	Sliders		Z [mm]	V [mm]	S [mm]	Num. of holes	B [mm]	Rail weight [kg/m]	Weight 4 sliders [Kg]
								Num. of rollers	Length [mm]							
TQAX	26	26	44	25	4	-	M5	3	80	25	30	14	2	28	1.6	0.4
	40	39.5	57.3	35	6	23	M6	3	135	7.5	120	0	4	0	3.1	1.5

When used in pair, the same rail can be installed left or right just by rotating it. See "Installation Instructions" on pg. TL-29.

Tab. 18

Technical instructions



> Telescopic rail selection

Selecting the suitable telescopic rail should be done based on the load and the maximum permissible deflection in the extended state. The load capacity of a Telerace telescopic rail depends on two factors: the load capacity of the rollers and the rigidity of the intermediate element. For

mainly short strokes the load capacity is determined by the load-bearing capacity of the rollers; for average and long strokes it is determined by the rigidity of the intermediate element.

> Deflection

If the load P acts vertically on the pair of rails (see fig. 42), the expected elastic deflection in the extended state can be determined as follows:

$$f = \frac{q}{t} \cdot P$$

Fig. 41

Whereby:

f is the expected elastic deflection [mm]

q is a stroke coefficient (see fig. 44)

t is a factor depending on the model of the telescopic rail (see fig. 43)

P is the actual load acting on the centre of a pair of rails [N].

The value resulting from the formula above is an estimation and also assumes an absolutely rigid adjacent construction. If this rigidity is not present, or in case the deflection is a key application requirement, please contact our Technical Department for a precise calculation.

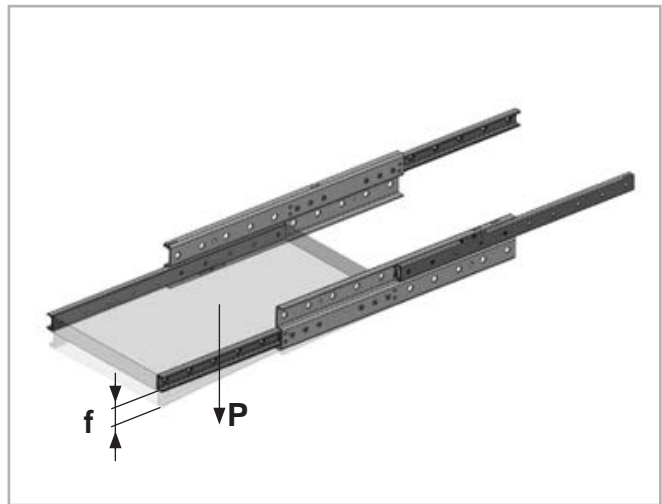

Fig. 42

TLR18P t=300	TQN30P t=120
TLR28P t=500	TQN40P t=420
TLR43P t=1200	
	TLAX26 t=185
TLQ18P t= 60	TLAX40 t=425
TLQ28P t=120	
TLQ43P t= 450	TQAX26 t=105
	TQAX40 t=420
TLN30P t=400	
TLN40P t=900	

Fig. 43

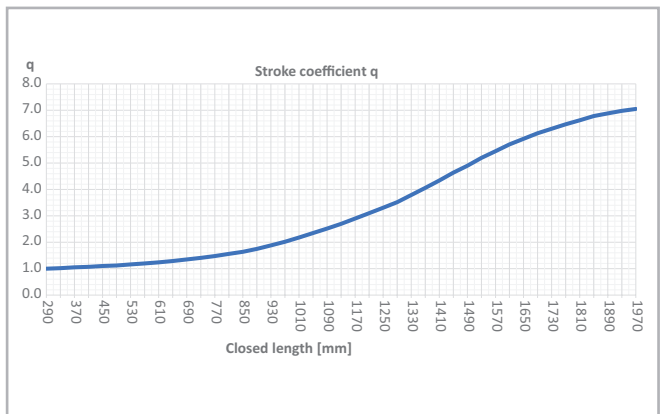

Fig. 44

> Sizing of telescopic applications

The main factors to consider while sizing the rail for a telescopic movement are:

- Weight of the mobile part and other applicable loads
- Presence of dynamic forces / eventual abuse
- Max. acceptable deflection
- Max. acceptable extraction/closing force of mobile part
- Environment, frequency and speed
- Expected lifetime

All load capacities C_{Orad} are indicated per pair of rails and with the load perfectly centered. Hereby the load P is acting as a radial point load, at half the extension and in the middle between the two rails. The load capacity for a single rail is obtained dividing the value C_{Orad} by half.

When sizing a telescopic application, consider the center of mass of the load and any external dynamic forces acting on the rails.

In case the actual load P isn't centered the equivalent load Pe must be calculated for the verification of load capacity explained on page TL-22.

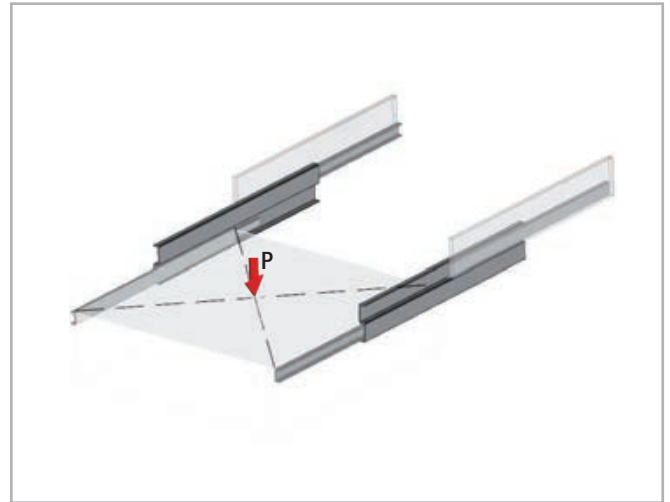

Fig. 47

$$Pe = 2 \cdot \frac{P \cdot d}{a + b} \cdot \frac{1}{fp}$$

Fig. 45

Where :

P = Weight/load of mobile part [N]

a, b = distances of the load center with respect to left and right rail [mm].

d = the largest between "a" and "b", according to the load position [N].

fp = Load position coefficient, based on relation between the value "c" (distance between actual load P and load C_{Orad}) and stroke H . The coefficient fp is obtained from diagram in Fig. 49.

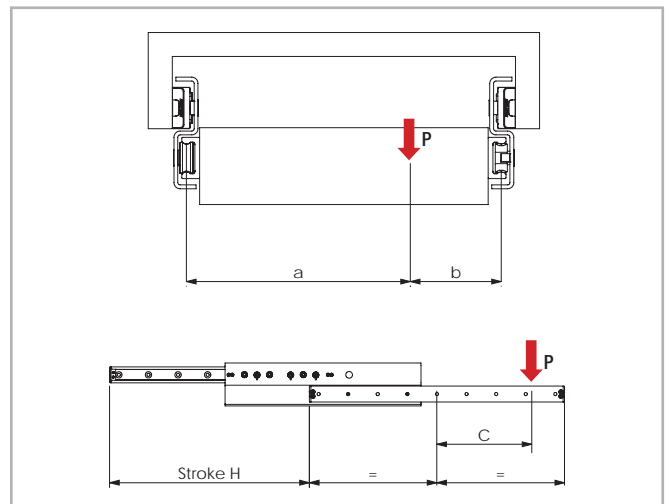

Fig. 48

For a single rail, Pe is obtained with the following formula:

$$Pe = \frac{P}{fp}$$

Fig. 46

Load capacity reduction according to the position of the load P

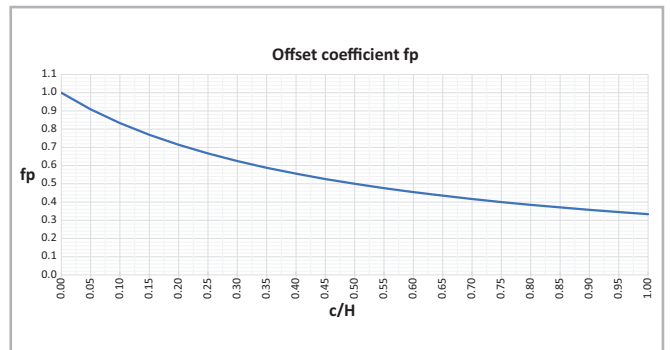

Fig. 49

> Verification of load capacity

Verification of the load capacity assumes the knowledge of the forces acting on the rails in the different directions, divided into principal components correspondent to the values indicated in the tables of the product pages: radial loads, axial loads and moments.

For the telescopic rails with intermediate element TLR...P, TLN...P and TLAX the verification is mainly down to comparing the load capacity C_{Orad} to Pe , including a safety factor S_0 .

$$Pe \leq C_{Orad} / S_0$$

Fig. 50

Where S_0 is the safety coefficient as per below table

Safety coefficient - S_0	Application conditions
1 - 1.5	Neither shocks nor vibrations, smooth and low-frequency reverse, high assembly accuracy, no elastic deformations
1.5 - 2	Normal installation conditions
2 - 3.5	Shocks and vibrations, high-frequency reverse, significant elastic deformation

Tab. 19

For telescopic rails TLQ...P, TQN...P and TQAX the calculation might also includes moments and axial load.

$$\left(\frac{Pe_{ax}}{C_{Oax}} + \frac{Pe_{rad}}{C_{Orad}} + \frac{Me_x}{M_x} + \frac{Me_y}{M_y} + \frac{Me_z}{M_z} \right) \leq \frac{1}{S_0}$$

Fig. 51

Where:

Pe_{rad} = applied radial load

Pe_{ax} = applied axial load

Me_x^* , Me_y , Me_z = applied moments

C_{Orad} = radial load capacity

C_{Oax} = axial load capacity

M_x , M_y , M_z = moment capacities

* Me_x moment exist only in case of use a single telescopic rail

If using a single telescopic rail, the values C_{Orad} , C_{Oax} , M_y and M_z in the formula Fig. 51 must be divided by 2 (M_x is always and only referred to a single rail).

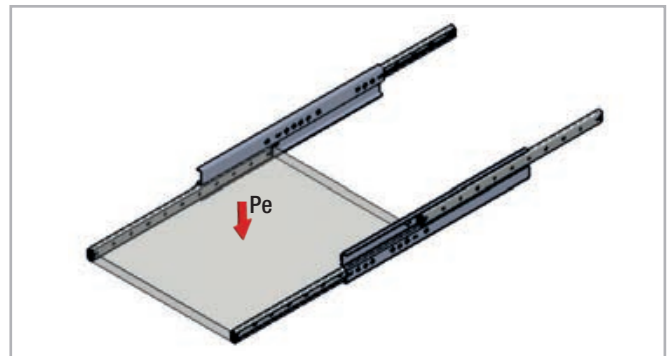

Fig. 52

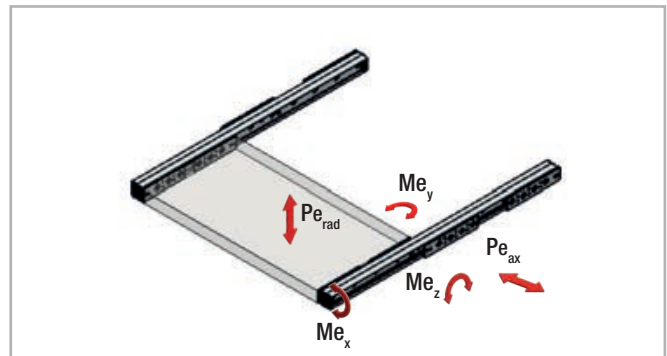

Fig. 53

> Lifetime calculation

The service life is defined as the time span between commissioning and the first sign of fatigue or wear indications on the raceways. The service life of a telescopic rail is dependent on several factors, such as the effective load, the installation precision, occurring shocks and vibrations, the operating temperature, the ambient conditions and the lubrication.

Calculation of the service life is based exclusively on the loaded ball bearings. In practice, the decommissioning of the bearing, due to its destruction or extreme wear of a component, represents the end of service life.

This is taken into account by an application coefficient (f_i in the formula below), so the service life consists of:

$$L_{cy} = 50 \cdot \left(\frac{C}{P_e} \cdot \frac{1}{f_i} \right)^3 \cdot \frac{1}{H} \cdot 10^6$$

$$L_{km} = 100 \cdot \left(\frac{C}{P_e} \cdot \frac{1}{f_i} \right)^3$$

L_{cy} = calculated service life [num. of cycles]
 L_{km} = calculated service life [Km]
 C = Dynamic load coefficient
 P_e = Equivalent load applied [N]
 H = Stroke [mm]
 f_i = Application coefficient

Fig. 54

Application coefficient f_i

The correction factor f_i applied to the theoretical calculation formula has the sole purpose of guiding the designer quantitatively on the influence in the lifetime estimation of the real application conditions without any pretense of precision. For more details please contact our technical department.

Equivalent load applied P_e

When the load P is not perfectly centered, the equivalent load P_e must be calculated as shown in Fig. 45, otherwise, with the load perfectly centered:

$$P_e = P_{rad}$$

Fig. 55

When using a pair of telescopic rails series TLQ, TQN and TQAX, in presence of simultaneous load P_{rad} , P_{ax} and moments M_y , M_z (M_x only in case of single rail) :

$$P_e = C_{o_{rad}} \cdot \left(\frac{P_{e_{rad}}}{C_{o_{rad}}} + \frac{P_{e_{ax}}}{C_{o_{ax}}} + \frac{M_{e_x}}{M_x} + \frac{M_{e_y}}{M_y} + \frac{M_{e_z}}{M_z} \right)$$

Fig. 56

If using a single telescopic rail, the values $C_{o_{rad}}$, $C_{o_{ax}}$, M_y and M_z in the formula Fig. 57 must be divided by 2 (M_x is always and only referred to a single rail).

Coefficient f_i	Operating conditions
1 - 1.5	Correct load sizing, rigid structures, routine lubrication, clean ambient
1.5 - 2	Intermediate conditions
2 - 3.5	Approximative load sizing, unprecise non rigid structures, dusty not clear ambient.

Tab. 20

> Opening and closing force

For applications requiring very low opening and closing forces, the rails series TLR...P and TLQ...P are recommended. The required force F_e to extend a pair of rails is determined by the friction of the rolling elements and the applied load P , according to the following formula:

$$F_e \approx k + 0.01 \cdot P$$

Fig. 57

The required force F_c to close a pair of rails is also influenced by the deflection and the stroke, according to the the following formula:

$$F_c \sim k + 0.01 \cdot P + 1.5 \cdot \frac{f}{H} \cdot P$$

Fig. 58

Where :

P = radial load applied on the pair of rails

f = calculated deflection

H = stroke

k = friction force per pair of telescopic rails connected without load applied

These calculated values may be influenced by some additionnal binding friction from non precise assembly or structure. For a single rail, the same formulas can be used.

TLR18P / TLQ18P	k=10 N
TLR28P / TLQ28P	k=15 N
TLR43P / TLQ43P	k=25 N

Fig. 59

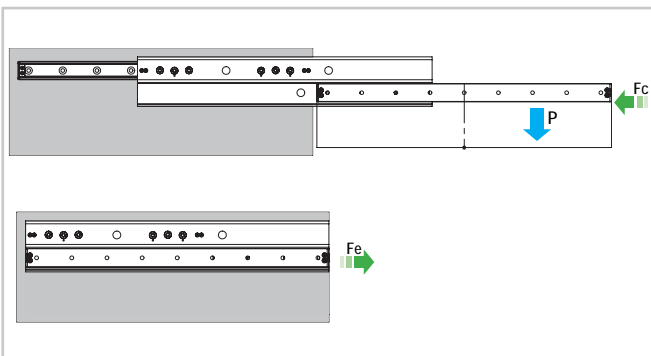

Fig. 60

> Lubrication

TLR...P and TLQ...P rails are equipped with internal wipers with slow release felts that ensure a proper lubrication of the raceways for all the product's lifetime if the rail is used in indoor, clean, environments. The rollers are also lubricated for life. If used in harsh environments (eg. dirt, temperature, humidity) it is necessary to periodically clean and lubricate the raceways.

TLN...P, TQN...P, TLAX and TQAX rails only feature rollers lubricated for life. The raceways must therefore be lubricated every 100.000 cycles if they are used in indoor, clean, environments. If used in harsh environments (eg. dirt, temperature, humidity) the lubrication interval must be reduced and it is necessary to periodically clean the raceways.

Raceways are lubricated with a lithium lubricant of average consistency (roller bearing lubricant). Different lubricants are available on request for special applications:

- FDA-approved lubricant for use in the food industry
- specific lubricant for clean rooms
- specific lubricant for the marine technology sector
- specific lubricant for high and low temperatures

For more details please contact our technical department.

> Anticorrosion treatments

TLR...P / TLQ...P

Treatment	Characteristics
Rollon-Nox	Patented high depth nitride hardening and black oxidation treatment that provides good durability under high loads or frequencies. It is standard for size 18 and it's not available for other sizes.
Zinc Plating ISO 2081	Standard treatment for rails sizes 28-43, it is ideal for indoor applications. It is removed from the raceways by the subsequent grinding process. Zinc-plated telescopic rails are supplied with steel rollers.
ZincNickel ISO19598 (Z)	Ideal for outdoor applications. Telescopic rails with this treatment are supplied with stainless steel rollers to further increase the corrosion resistance.
Rollon E-coating (K)	Electro painting that provides a fine black finishing to the entire rail. It can be partially removed from the raceways on the running contact point of the rollers after a period of use. Telescopic rails with Rollon E-Coating are supplied with stainless steel rollers to further increase the corrosion resistance.
Nickel Plating (N)	Provides high resistance to chemical corrosion and is ideal for applications in medical or food related environments. Raceways are coated too. Telescopic rails with Nickel Plating treatment are supplied with stainless steel rollers to further increase the corrosion resistance.

Tab. 21

TLN...P / TQN...P

Treatment	Characteristics
Rollon-Nox	Patented high depth nitride hardening and black oxidation treatment that provides good durability under high loads or frequencies and good corrosion resistance. It is standard for all sizes.
Rollon E-coating (K)	Electro painting that provides a fine black finishing to the entire rail. It can be partially removed from the raceways on the running contact point of the rollers after a period of use. Telescopic rails with Rollon E-Coating are supplied with stainless steel rollers to further increase the corrosion resistance.

Tab. 22

TLAX / TQAX

As standard, TLAX and TQAX feature rails and intermediate S-element in AISI304 and Rollers in hardened AISI440.

Treatment	Characteristics
Electro-polish (X)	Rails and intermediate element are completely electro-polished for further improved corrosion resistance. The electro-polishing treatment also gives the product a very shiny surface.

Tab. 23

> Speed

The speed of the rails is limited by the strength of the stoppers that take on the intermediate element with each opening/closing. At the same speed, the impact force increase proportionally to the length of the rail and the weight of the intermediate element.

All Telerace telescopic rails feature robust end-stoppers capable of sustaining high speeds. Besides highest speed, the telescopic rails with ball bearing rollers are also less sensitive to frequent and intense accelerations and decelerations due to absence of the ball cage.

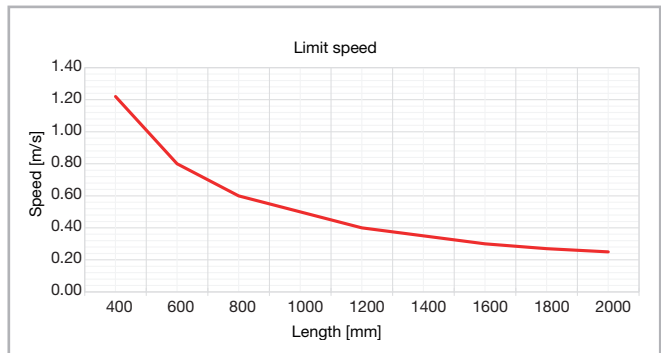

Fig. 61

> Self-aligning system with TLR...AP

TLR...P telescopic rails are also available in the TLR...AP version that allows a slight rotation of the movable element around the longitudinal axis, with respect to the fixed element. This rotation is obtained by using a combination of floating and guiding rollers and allows the rail to adapt to mounting surfaces that are not perfectly aligned in their frontal part, avoiding the overload of the rollers and the deterioration of the motion quality. This same rotation also permits a slight compensation of an eventual dimensional gap between the fixed and mobile structures, that may occur due to manufacturing tolerances, with respect to the nominal dimensions of the rail.

Below are listed 3 examples of compensation of structural errors:

A) Maximum angular compensation (α_1) of misaligned mounting surfaces of the mobile structure.

B) Maximum angular compensation (α_2) of misaligned mounting surfaces of the fixed structure

C) Maximum linear compensation (B) of the dimensional gap between mobile and fixed structure for a rail with parallel mounting surfaces.

The compensating rail TLR...AP must be used in pair with a guiding rail TLR...P to ensure the perfect operation of the system and an optimal lateral stability.

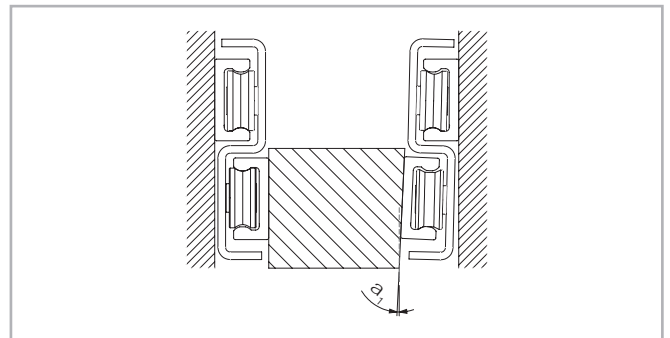

Fig. 62

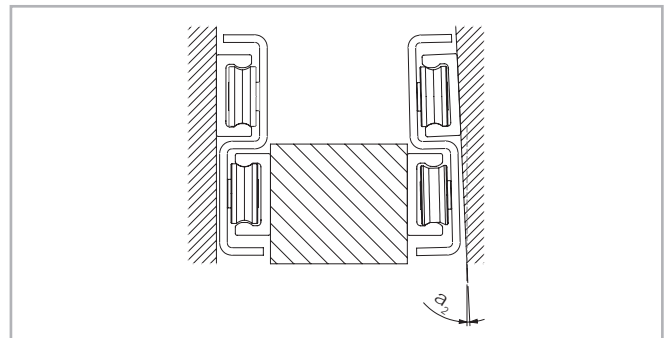

Fig. 63

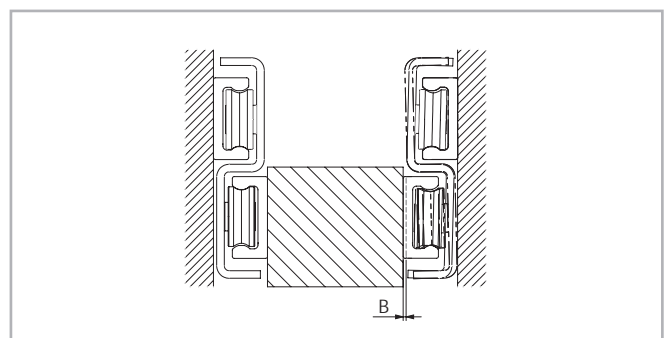

Fig. 64

Size	α_1 [°]	α_2 [°]	B [mm]
18	1	1	0.3
28	0.85	0.85	0.3
43	1.3	1.3	0.5

Tab. 24

> Stroke customization for TLQ...P, TQN...P, TQAX

TLQ...P, TQN...P and TQAX series offer the unique possibility to easily customize the actual stroke H to individual needs. This is obtained by repositioning the slider distance "A" for "Fixed sliders" and distance "B" for "Mobile sliders", with different distances than standard. Please consider that distance A should always be longer than distance B to maximize the load capacity. If the distance between fixed sliders "A" and mobile sliders "B" is reduced the total stroke increases and the load capacity decreases. Viceversa, the total stroke decreases and the load capacity is improved. Please contact our technical department for load capacities according to customized stroke.

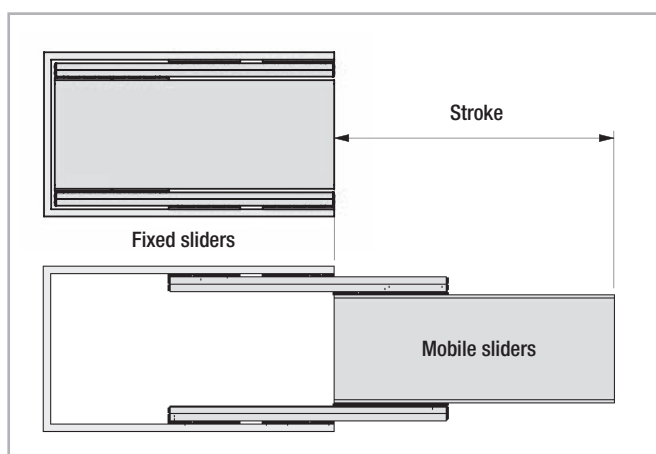

Fig. 65

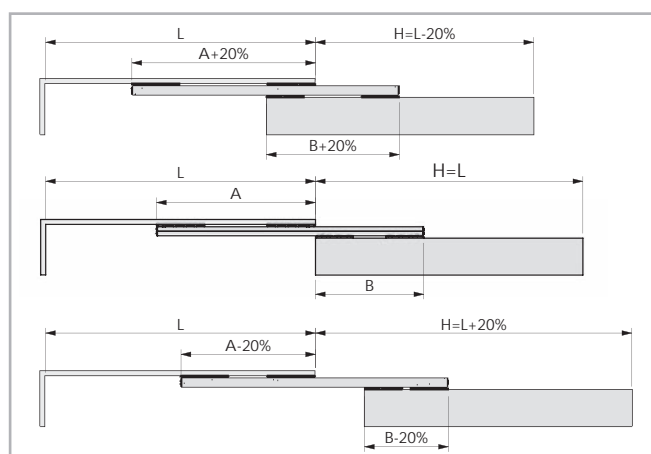
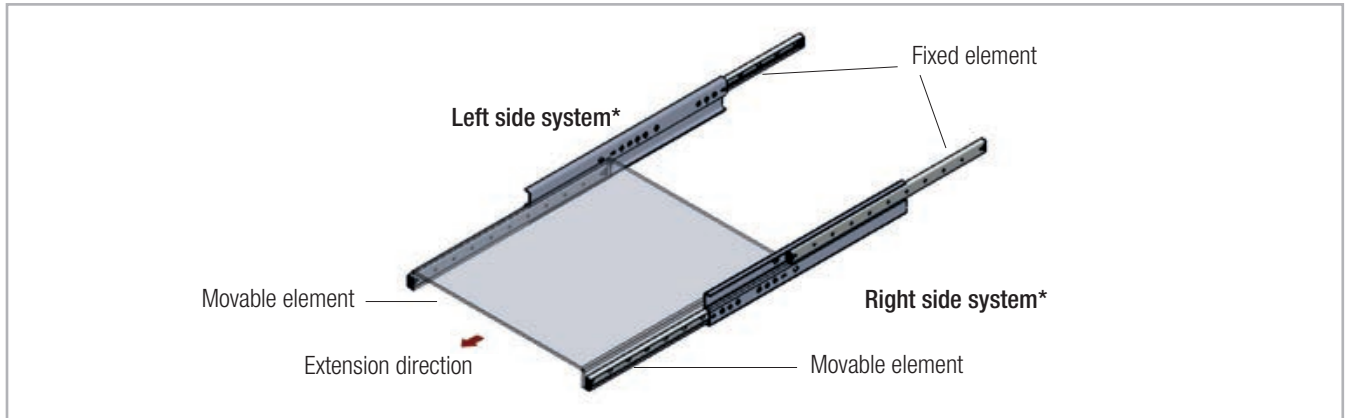

Fig. 66

> Installation instructions

In general and for specific product series



* For model TLR...P and TLN...P please observe right or left side use.

Fig. 67

General

- To achieve optimum running properties, high service life and rigidity, it is necessary to fix the telescopic rails with all accessible holes on a rigid and level surface.
- Please observe the parallelism of the installation surfaces. The fixed and movable rails must be fit to a rigid assembly construction.
- Telerace rails are suitable for continuous use in automatic systems, even when the stroke is not constant.
The operating speed must be checked (see pag. TL-26).

TLR...P, TLN...P, TLAX

- This series accept radial loads. This should act in the vertical cross-sectional axis on the movable rails.
- Horizontal and vertical application is possible. Prior to vertical installation, please contact our technical department.
- When installing make sure that the load is placed on the movable element (the lower rail) (see fig. 67). The opposite assembly negatively affects the function.
- Installation must be done on a rigid structure using all accessible fixing holes.
- Pay attention to the parallel alignment during assembly with paired application. It is possible to compensate minor misalignment errors by pairing TLR...P with TLR...AP (see pag. TL-27)

TLQ...P, TQN...P, TQAX

- This series accept radial and axial loads and moments in all principal directions.
- Horizontal and vertical applications are possible. Prior to vertical installation, please contact our technical department.
- The rail must be installed with the label facing upward. The fixed sliders have the circular engraving mark facing upward, while on the mobile sliders the same mark is facing downward.
- When used in pairs, the same rail can be used as left or right rail, always keeping the mark facing upwards.

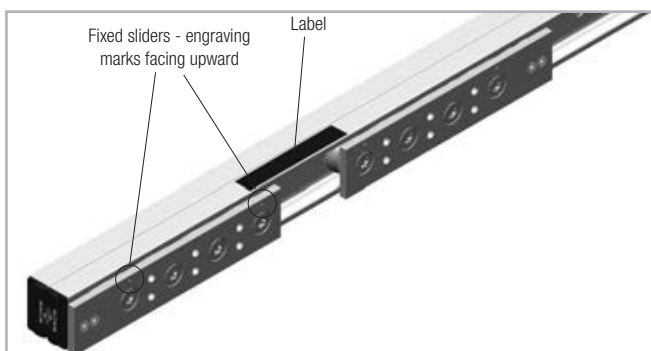

Fig. 68

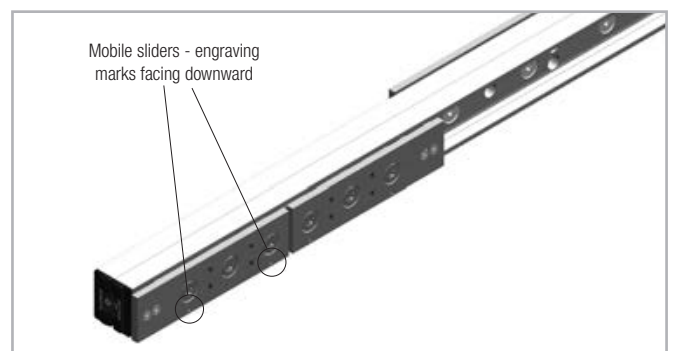

Fig. 69

> Fixing screws

TLR...P

We recommend countersunk head screw according to DIN 7991

Type	Size	V
TLR...P	18	M4
	28	M5
	43	M8

Tab. 25

TLQ...P

We recommend fixing screws according to DIN 912 for the fixed sliders in TLQ...P and fixed and mobile sliders in TLQ...PC.

Type	Size	F
TLQ...P	18	M4
	28	M5
	43	M8

Tab. 26

TLN...P, TQN...P, TLAX, TQAX

We recommend fixing screws according to ISO 7380 with low head height or TORX® screws (see fig. 70) on request.

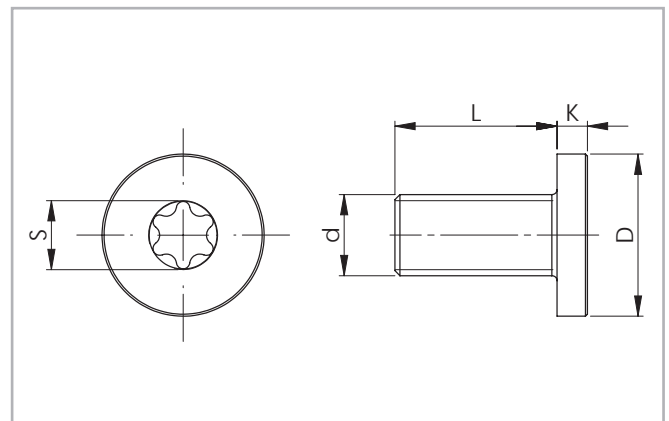

Fig. 70

Rail size	Screw type	d	D [mm]	L [mm]	K [mm]	S	Tightening torque [Nm]
26	M5 x 10	M5 x 0.8	10	10	2	T25	9
30	M5 x 10	M5 x 0.8	10	10	2	T25	9
40	M8 x 16	M8 x 1.25	16	16	3	T40	20

Tab. 27

> **TQN...P**

TQN	30P	-1490			
	Size	Length			
Product type					

Ordering examples: TQN30P-1010.

Note on ordering: please pad with zeroes to fill in for lengths with less than 4 digits, e.g. 550 mm length is "0550".

> **TLAX / TQAX**

TLAX	26	-1490	Q		
	Size	Length	Surface treatment (if different from standard)		
Product type					

Ordering examples: TLAX26-1000Q; TQAX40-0700.

Note on ordering: rail lengths are always stated with 4 digits. Please pad with zeroes to fill in for lengths with less than 4 digits, e.g. 550 mm length is "0550".

Notes



A large grid of graph paper for taking notes, consisting of approximately 26 columns and 40 rows of small squares.

ROLLON[®]
BY TIMKEN

Light Rail



Light Rail

A renewed range of rolled steel telescopic rails with light structure and full or partial extension: **4 main advantages.**

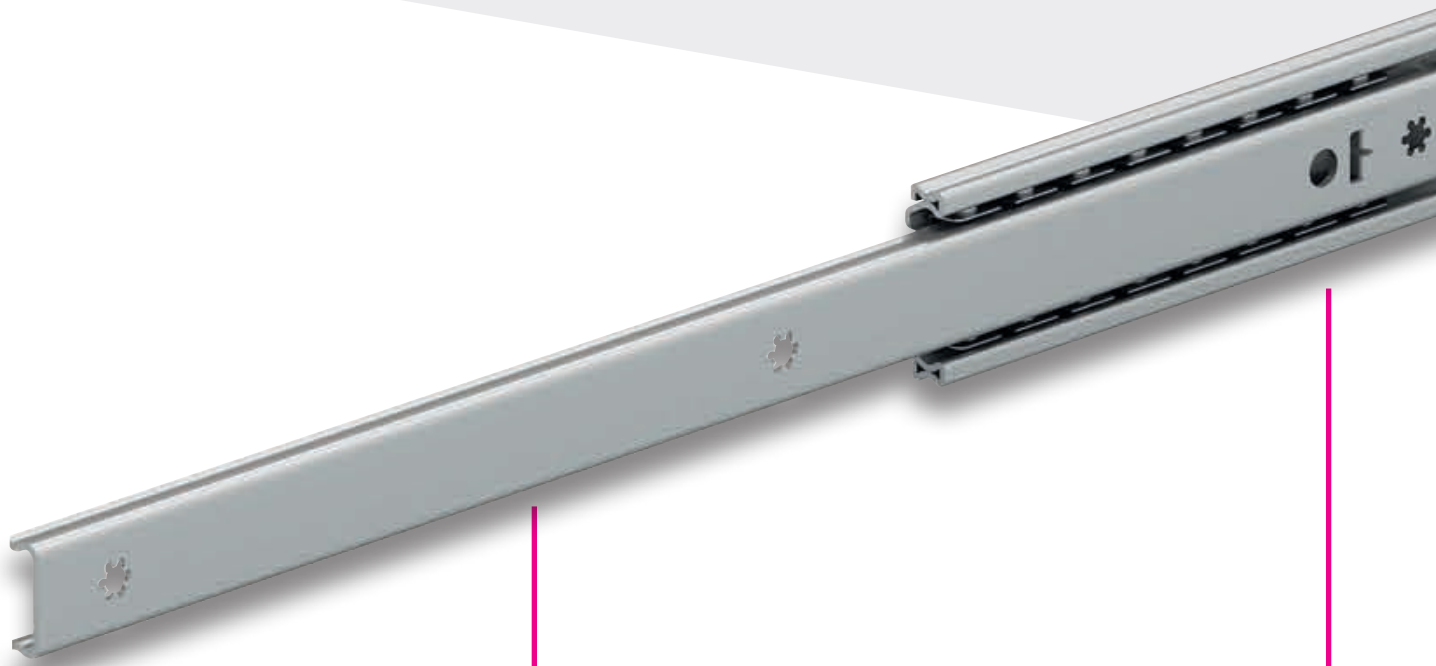

1

Low deflection

Good rigidity in relation to a lightweight design



2

Quiet sliding

Smooth and silent movement with heavy loads.



3

Low maintenance

Lubricated with heavy duty ball bearing grease based on mineral oil.

13.5 to 19.1 mm

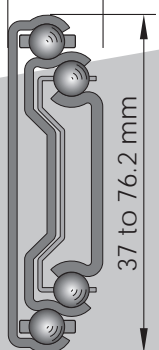

37 to 76.2 mm



4

Space saving

Compact overall dimensions make them ideal for medium and lightweight drawers.

Structural elasticity capable of absorbing minor impacts.

Product explanation



> Light telescopic rails with full or partial extension



Fig. 1

Light Rail is the product family of lightweight telescopic rails with full and partial extension, ideal for applications in which the mass of the rail is just as important as the bending rigidity.

End stoppers allow smooth and quiet operation even with heavy loads applied and avoid permanent distortion in case of eventual shocks.

Different options are available depending on the rail size (e.g. locking systems in open and/or closed position) and further customizations (eg. lengths, strokes) are possible.

The Light Rail product family is available in 5 sizes (37-46-56-71-76) and features partial, full extension or overextending, with a wide range of use that spans from light-duty applications, such as kitchen drawers or office furniture, to more demanding ones in industrial automations or special vehicles.

The most important characteristics:

- Light and quiet running
- Long service life with low maintenance
- High reliability
- Structural elasticity capable of absorbing minor impacts and absence of permanent deformation
- Not sensitive to side impacts

Preferred areas of application:

- Beverage industry
- Automotive
- Construction and machine technology (e.g., housing)
- Packaging machines
- Railcars (e. g., maintenance and battery extensions)
- Special machines

LRS37

Partial extension telescopic rail made of cold rolled, low carbon steel, interconnected with a ball bearing cage and treated with corrosion resisting zinc-plating ISO 2081 with blue passivation. It features end stoppers which reduce noise function, and is ideal for light-duty applications such as kitchen and bathroom drawers as well as office furniture.



Fig. 2

LFS46

Full extension telescopic rail with detachable internal element, which can be released with a latch. Rails are made of steel, the ball cages of steel and plastic. Roll back protection in closed position.



Fig. 3

LRS56-71

Full extension telescopic rail made of cold rolled, low carbon steel rails interconnected with ball bearing cages and treated with corrosion resisting zinc-plating ISO 2081 with blue passivation. It features end stoppers with hold closed which reduces noise function and prevents the guide from opening by itself in closed position.



Fig. 4

LRS76

Full extension telescopic rail made of cold rolled, low carbon steel rails interconnected with ball bearing cages and treated with corrosion resisting zinc-plating ISO 2081 with blue passivation.

It features locking mechanisms to lock the slide in opened, closed, and both end positions.



Fig. 5

LRS710E

Telescopic rail with a 150% extension of its length made of cold rolled, low carbon steel rails interconnected with ball bearing cages and treated with corrosion resisting zinc-plating ISO 2081 with blue passivation.

It features end stoppers with rubber elements to reduce noise in closed position.



Fig. 6

Overview product cross sections



> Partial extension guides

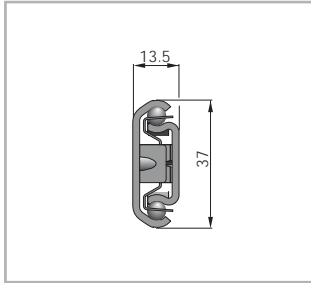

Fig. 7

LRS37

Load capacities p. LR-6

> Full extension guides

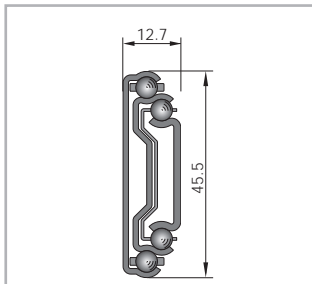

Fig. 8

LFS46

Load capacities p. LR-7

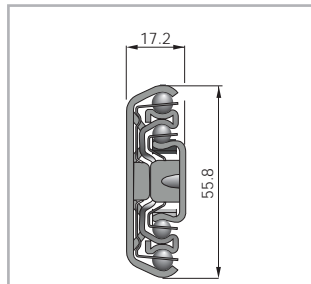

Fig. 9

LRS56

Load capacities p. LR-8

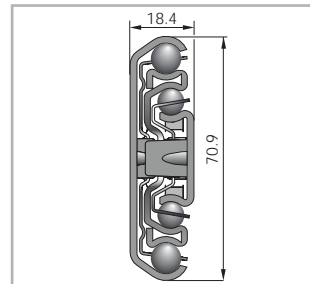

Fig. 10

LRS71

Load capacities p. LR-9

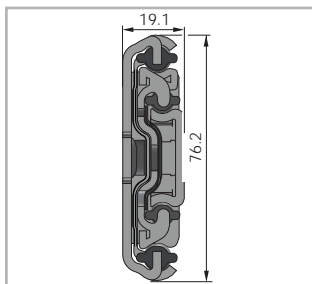

Fig. 11

LRS76

Load capacities p. LR-10

> Overextending guides

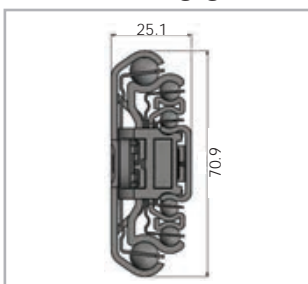

Fig. 12

LRS710E

Load capacities p. LR-11

LR-4

Technical data

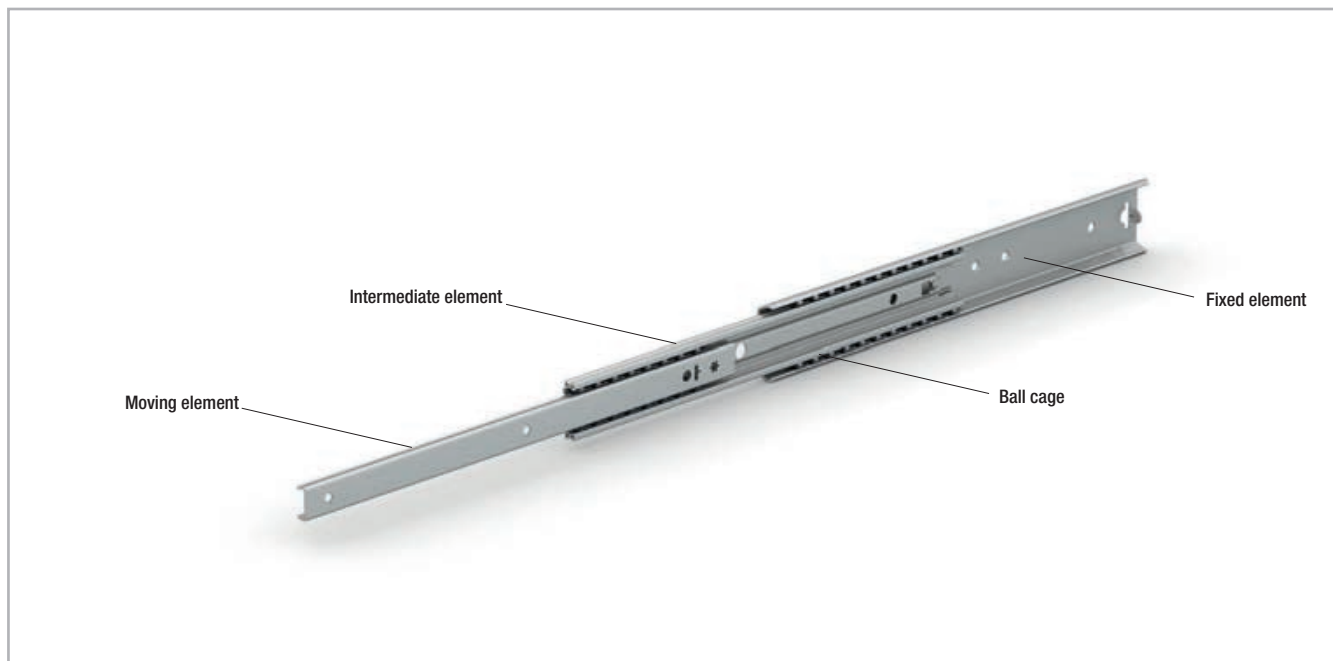

Fig. 13

Performance characteristics:

- Extension speed (depending on application):
 - Extension 100 - 500 mm: max. 0.5 m/s (19.69 in/s)
 - Extension 600 mm: max. 0.4 m/s (15.75 in/s)
 - Extension ≥ 700 mm: max. 0.3 m/s (11.81 in/s)
- Temperature range: LRS from -20°C to $+80^{\circ}\text{C}$ (depending on the application), LFS from $+10^{\circ}\text{C}$ to $+40^{\circ}\text{C}$ (depending on the application).
- All systems are lubricated with heavy duty ball bearing grease based on mineral oil.
- Rail material: cold rolled, low carbon and high yield strength steel.
- Ball cages material: electrolytically galvanized steel or plastics.
- Ball bearings material: hardened carbon steel.

Remarks:

- All load capacity data are based on a pair of telescopic rails
- Horizontal movement installation is recommended
- All strokes are subject to a general tolerance of ± 4 mm.
- Vertical movement installation on request, please contact our Technical Department.
- Assembly in cross-sectional width, here a positive tolerance of $+0.5$ mm is recommended (mounted under tension). If the extensions are installed with too small tolerances, the service life is decreased
- Cycle data applies to the use of an extension pair (recommended)
- Vertical use of extensions (radial load) is recommended
- Not suitable for moments – must be used in pair
- For alternative and specialized finishings, please contact our technical department.
- Customizations possible (eg. lengths, strokes, hold-in, soft close bumpers, ...). Please contact our technical department.
- The existing internal stops are not designed to stop the moving load. They are only supposed to retain the ball-cage and prevent the internal parts to slide out of the assembly. An external end-stop must always be installed to stop the moving load.
- For models LRS76 with locking in closed position (VG) and in closed and opened position (VB) please observe right or left side use

Dimensions and load capacity



> LRS37

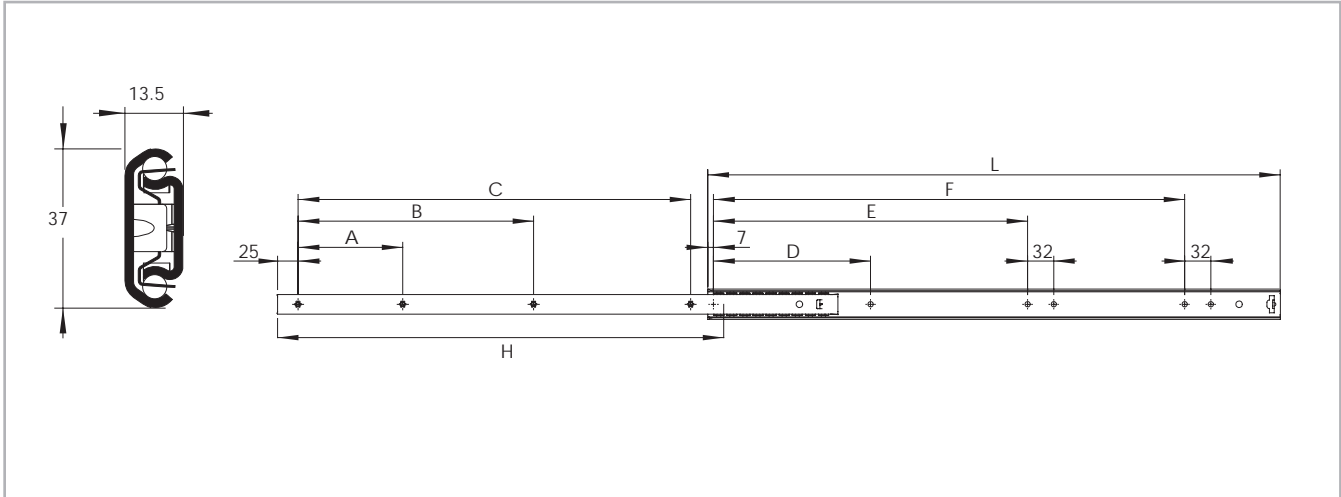

Fig. 14

Type	Size	Length L [mm]	Stroke H [mm]	Load capacity for a pair of rails		Moving element			Fixed element			Weight per single guide [kg]
				C _{Orad} [N] 10.000 Cycles	C _{Orad} [N] 100.000 Cycles	A [mm]	B [mm]	C [mm]	D [mm]	E [mm]	F [mm]	
LRS	37	300	205	780	600	32	96	128	128	192	-	0.45
		350	239	630	490	64	128	160		224	-	0.52
		400	289	540	420		224	-		0.6		
		450	339	460	360	160	256	320	-	0.67		
		500	373	540	420		96	192	288	160	288	384
		600	457	560	430	128	256	384	160	352	480	0.88
		700	541	560	430	128	288	480	192	384	576	1.08

Tab. 1

Note: The given load capacities are guidelines with uniform load distribution (area load) when using all mounting holes. The load values must be reduced in unfavorable conditions.

> LFS46

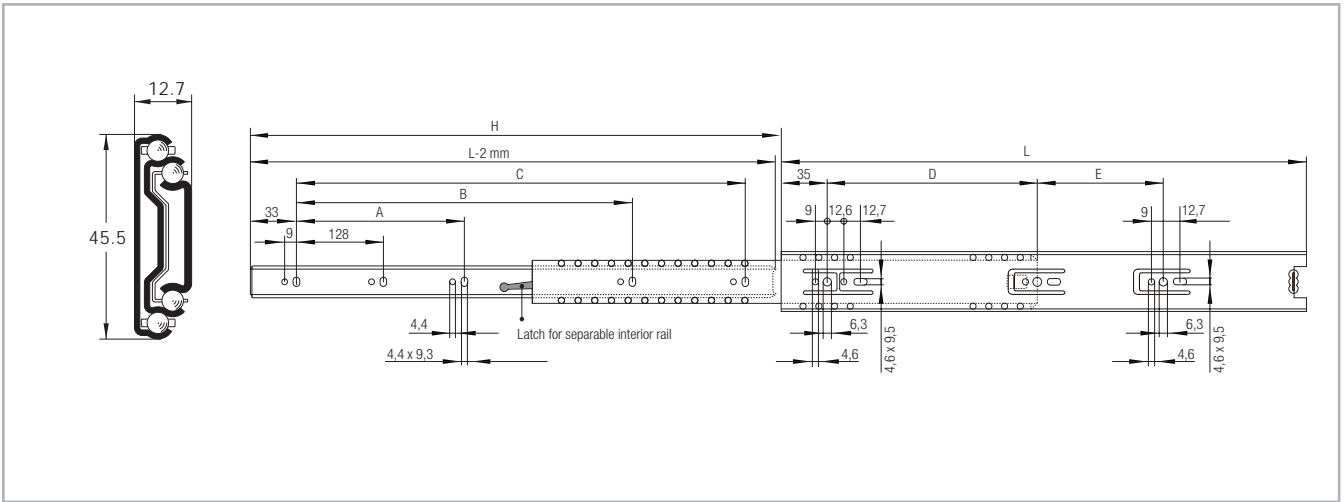

Fig. 15

Type	Size	Length L [mm]	Stroke H [mm]	Load capacity for a pair of rails	Moving element			Fixed element		Weight per single guide [kg]
				C_{Orad} [N] 50.000 cycles	A [mm]	B [mm]	C [mm]	D [mm]	E [mm]	
LFS	46	300	305	300	-	-	242	192	-	0,48
		350	356		-	-	292	256	-	0,51
		400	406	350	-	256	342	160	96	0,64
		450	457		-		392		160	0,71
		500	508		-	352	442	128	0,79	
		550	559	400	224	416	492	224	192	0,88
		600	610				542		224	0,95

Tab. 2

Note: The given load capacities are guidelines with uniform load distribution (area load) when using all mounting holes (at least one hole for each group must be used). The load values must be reduced in unfavorable conditions.

> LRS56

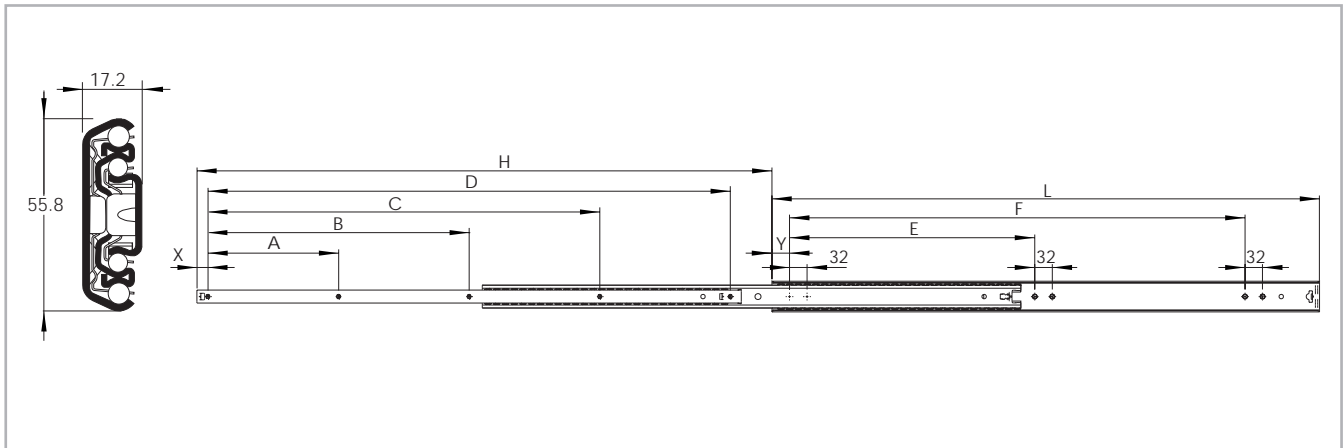

Fig. 16

Type	Size	Length L [mm]	Stroke H [mm]	Load capacity for a pair of rails		Moving element					Fixed element			Weight per single guide [kg]
				C _{Orad} [N] 10.000 Cycles	C _{Orad} [N] 100.000 Cycles	X [mm]	A [mm]	B [mm]	C [mm]	D [mm]	Y [mm]	E [mm]	F [mm]	
LRS	56	300	320	940	680	20	130	260	-	-	32	160	-	0.84
		350	375	960	770		155	310	-	-		-	0.98	
		400	440	970	730		180	360	-	-		192	-	1.12
		450	495	1100	830		205	410	-	-		256	-	1.26
		500	550	1190	900		230	460	-	-		288	-	1.42
		550	600	1180	910		255	510	-	-		320	-	1.56
		600	650	1230	970		280	560	-	-		384	-	1.70
		700	750	1290	1030		330	660	-	-		416	-	1.99
		800	848	1210	1020		251	502.5	754	-		352	640	2.25
		900	950	1050	900		285	569	854	-		384	736	2.58
	1000	1050	810	720	238.5	477	715.5	954	448	832	2.87			
	1100	1100	720	630	50	220	425	609	922	42.5	524	914	3.15	

Tab. 3

Note: The given load capacities are guidelines with uniform load distribution (area load) when using all mounting holes. The load values must be reduced in unfavorable conditions.

> LRS71

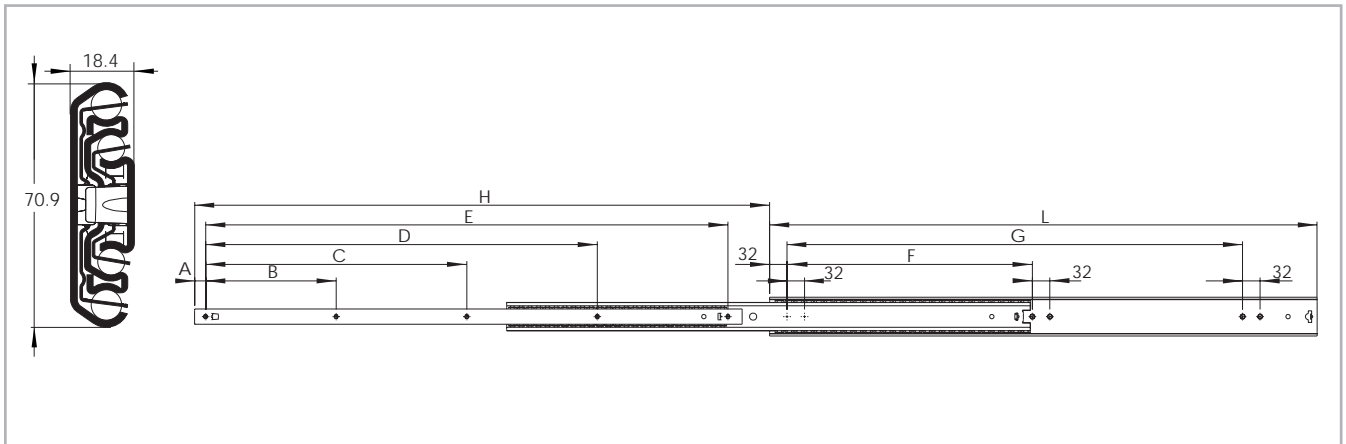

Fig. 17

Type	Size	Length L [mm]	Stroke H [mm]	Load capacity for a pair of rails		Moving element					Fixed element		Weight per single guide [kg]
				C _{0rad} [N] 10.000 Cycles	C _{0rad} [N] 100.000 Cycles	A [mm]	B [mm]	C [mm]	D [mm]	E [mm]	F [mm]	G [mm]	
LRS	71	400	435	1570	970	43	75	150	225	300	256	-	1.55
		450	485	1600	1030		87.5	175	262.5	350		-	1.75
		500	545	1690	1150		100	200	300	400		320	-
		550	595	1870	1180		112.5	225	337.5	450	-		2.40
		600	650	1890	1180		125	250	375	500	416	-	2.60
		700	750	1870	1370		150	300	450	600		-	2.80
		800	850	2120	1470	20	251	502.5	754	-	352	640	3.10
		900	950	1920	1250		285	569	854	-	384	736	3.58
		1000	1050	1790	1080		238.5	477	715.5	954	448	832	3.95
		1100	1100	1710	1010		50	220	425	640	926	520	932

Tab. 4

Note: The given load capacities are guidelines with uniform load distribution (area load) when using all mounting holes. The load values must be reduced in unfavorable conditions.

> LRS76

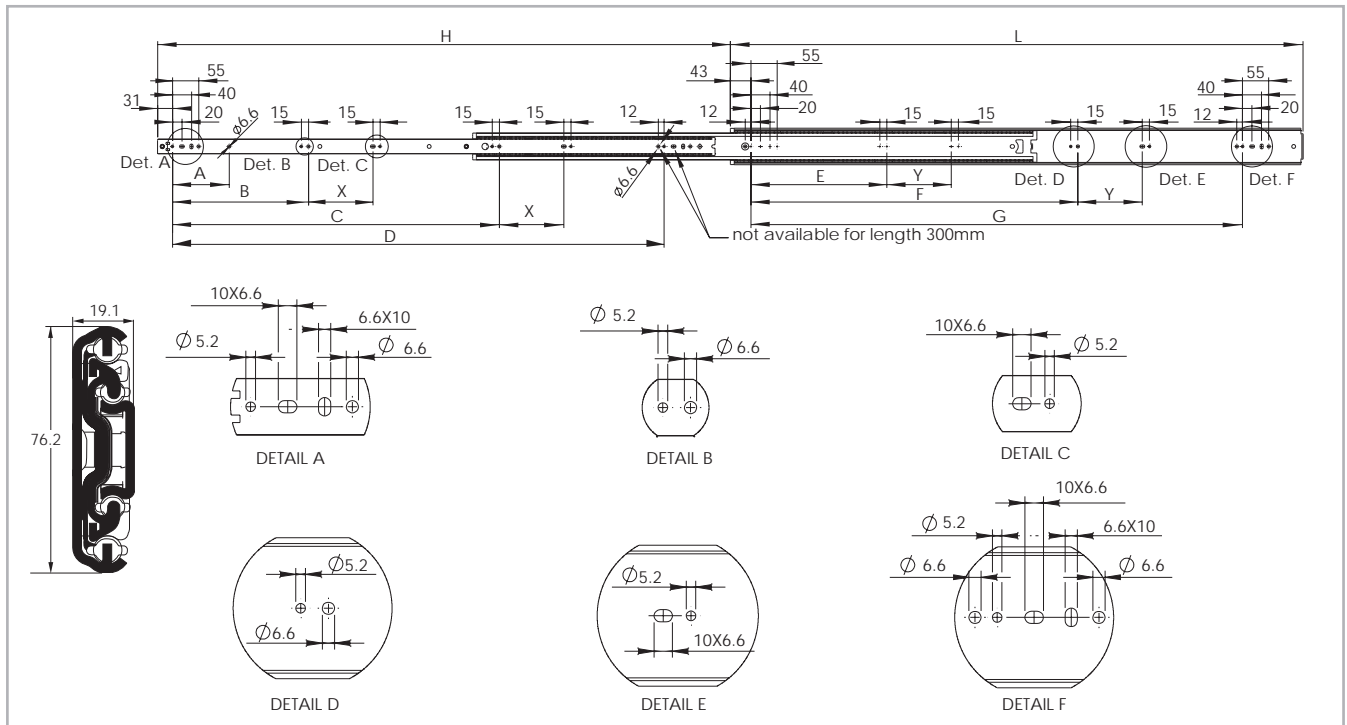

Fig. 18

Type	Size	Length L [mm]	Stroke H [mm]	Load capacity for a pair of rails		Moving element						Fixed element					Weight per single guide [kg]
				C_{0rad} [N] 10.000 Cycles	C_{50rad} [N] 50.000 Cycles	A [mm]	B [mm]	C [mm]	D [mm]	E [mm]	F [mm]	G [mm]	I [mm]	J [mm]	K [mm]	M [mm]	
LRS	76	300	298	2250	1950	-	-	-	-	-	130	-	-	-	130	1.40	
		350	366	2350	2000	-	-	-	-	-	180	-	-	-	180	1.65	
		400	398	2500	2100	118	-	-	-	-	230	-	-	-	230	1.90	
		450	464	2550	2200	142	-	-	-	-	280	-	-	-	280	2.13	
		500	512	2600	2300	186	-	-	-	-	330	-	-	-	330	2.40	
		550	562	2650	2400	186	-	-	-	-	380	-	-	-	380	2.65	
		600	610	2750	2550	-	185	355	-	-	430	185	320	-	-	430	2.90
		650	660	2850	2650	-	185	355	-	-	480	185	320	-	-	480	3.15
		700	708	2950	2800	-	285	420	-	-	530	185	320	-	-	530	3.40
		750	758	3000	2900	-	285	420	-	-	580	185	370	-	-	580	3.65
		800	806	3100	3000	-	285	455	-	-	630	285	420	-	-	630	3.90
		850	854	3150	3000	-	335	520	-	-	680	285	420	-	-	680	4.15
		900	904	3200	3100	-	385	520	-	-	730	285	420	-	-	730	4.40
		1000	1000	3250	3150	-	385	555	-	-	830	385	520	-	-	830	4.90
		1100	1098	3050	2900	-	235	420	635	770	930	235	420	585	770	930	5.40
		1200	1212	2950	2800	-	285	420	685	820	1030	285	420	685	820	1030	5.90
		1350	1358	2450	2100	-	285	455	785	920	1180	285	420	785	920	1180	6.65
1500	1504	2250	1950	-	358	520	885	1020	1330	385	520	885	1020	1330	7.40		

Tab. 5

Note: The given load capacities are guidelines with uniform load distribution (area load) when using all mounting holes (at least one hole for each group must be used). The load values must be reduced in unfavorable conditions. Please observe right or left installation for version LRS76 with locking mechanisms in closed position (VG) and in closed and opened position (VB).

> LRS710E

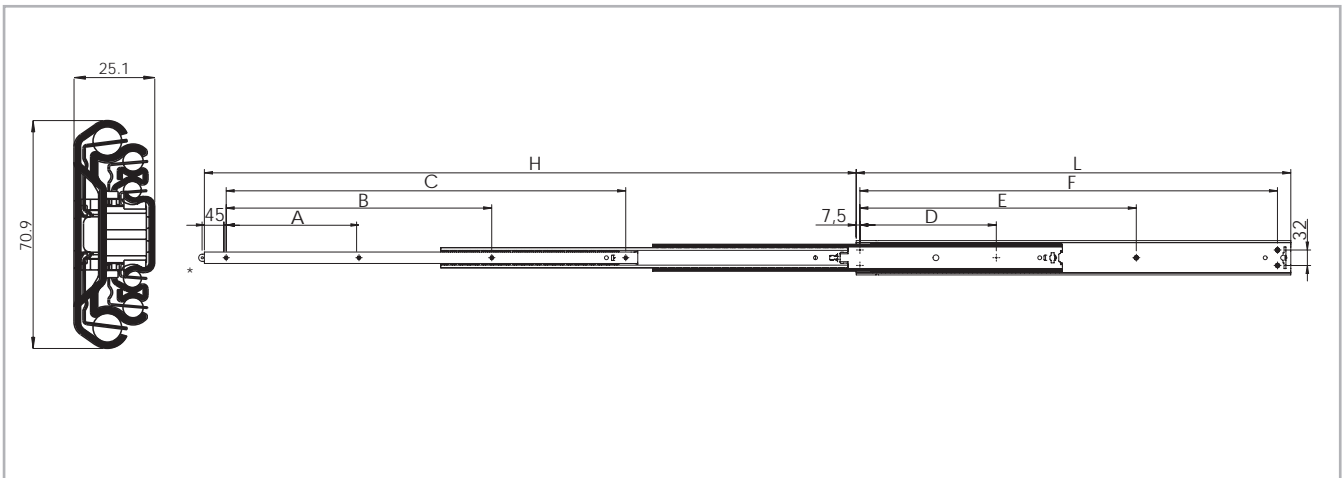

Fig. 19

Type	Size	Length L [mm]	Stroke H [mm]	Load capacity	Moving element			Fixed element		
				C_{Drad} [N] 10.000 Cycles	A [mm]	B [mm]	C [mm]	D [mm]	E [mm]	F [mm]
LRS	710E	300	395	800	105	-	227.5	142.5	-	265
		400	595	900	115	218	327.5	192.5	-	365
		500	750		145	290	427.5	155	310	465
		600	900	1000	170	340	527.5	182.5	372.5	565
		700	1050		200	400	627.5	212.5	432.5	665
		800	1200		240	480	727.5	247.5	502.5	765
		900	1350		275	550	827.5	282.5	572.5	865

Tab. 6

Note: The given load capacities are guidelines with uniform load distribution (area load) when using all mounting holes (at least one hole for each group must be used). The load values must be reduced in unfavorable conditions.

Accessories



Available options (depending on telescope version)

> Locking

Locking mechanisms make it possible to lock the Light Rail in opened, closed, or both end positions. This prevents inadvertent extension or retraction of the rail in any case. This ensures personal safety and protection of materials, especially in moving installations, as in vehicles.

> Damping

Light Rail telescopic rails can be equipped with damped end stops in closed position. The damping elements provide quieter operation, a softer end stop when pushing in the rail, and higher resistance at the end of the stroke.

> Snap

Light Rail telescopic guides can be equipped with a snap. Thus, an unintended process of the telescope system is avoided.

Note: Not all accessories (damping, snap) can be combined with each other and available. (see Technical features overview) Please contact our technical service.

Technical instructions

> Load capacities

Vertical installation (radial load)

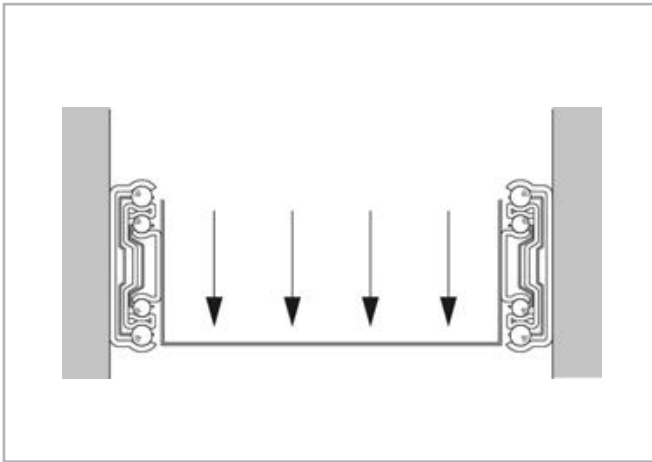

Fig. 20

The given loading capacities are guidelines for a pair of rails vertically mounted with uniform load distribution using all mounting holes (for LFS46 and LRS76 at least one hole of each group must be used). The load values must be reduced in unfavorable conditions.

> Overall dimension

When installing the rail, its nominal overall dimension relative to the side of the drawer/cabinet must be kept in mind. The overall dimension is the thickness of the rail plus 0.5 mm ± 0.25. The thickness of the rail is measured with the ball cage in the closed position. Be sure to leave at least 5 mm of clearance behind the drawer.

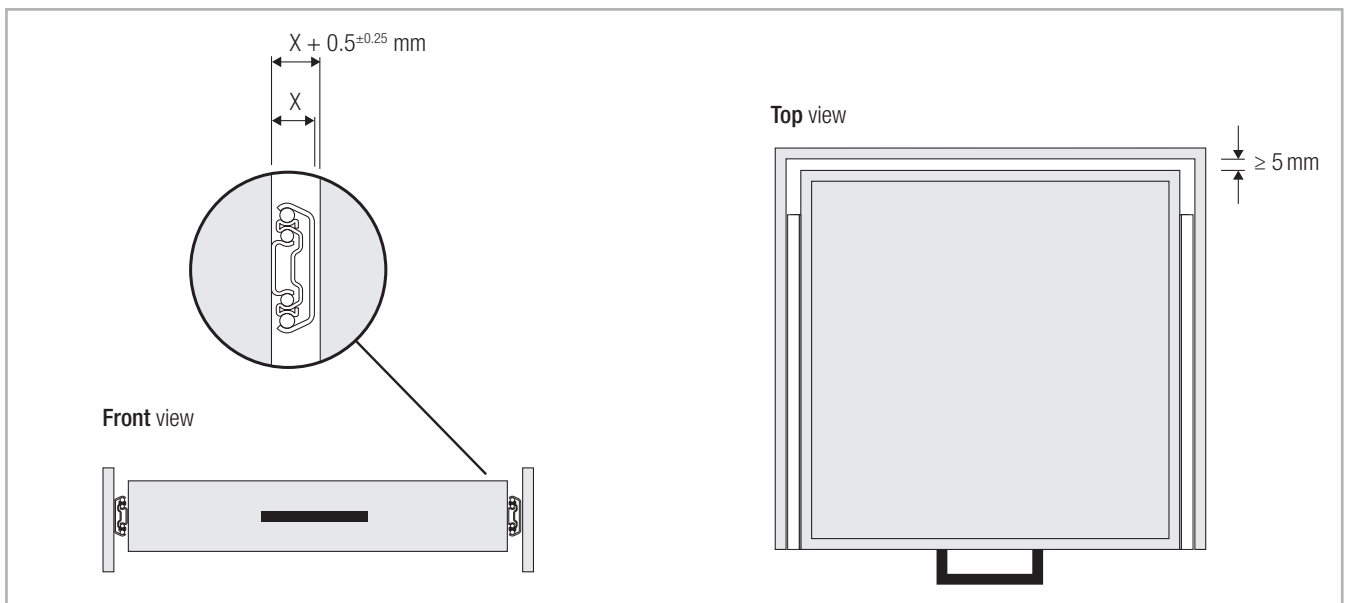

Fig. 21

> Alignment

When positioning the rails, it is important that they are aligned accurately, within the specified tolerances. The more precisely the guide rails are aligned, the smaller the chance that they will work against each other.

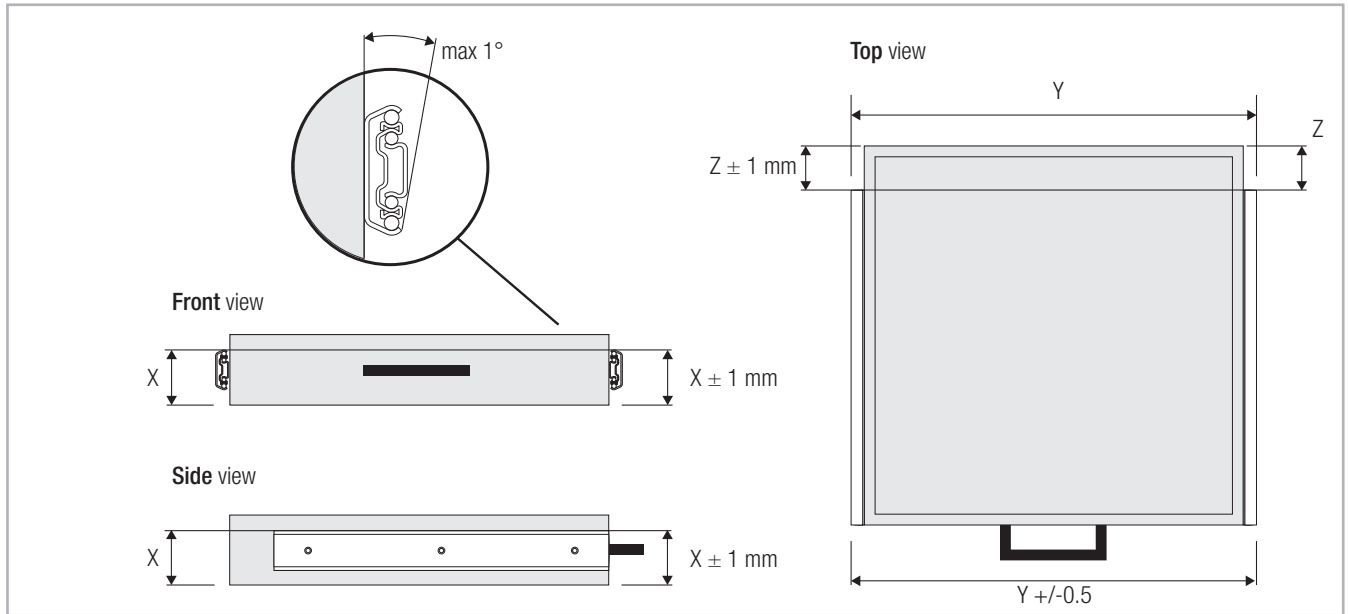

Fig. 22

> Stroke tolerance

The given strokes in the „Dimensions and load capacity“ chapter are subject to a general tolerance of ± 4 mm.

> Distances

The pair of rails are tested at a maximum width of 600 mm. For distances wider than 600 mm, please contact our technical department.

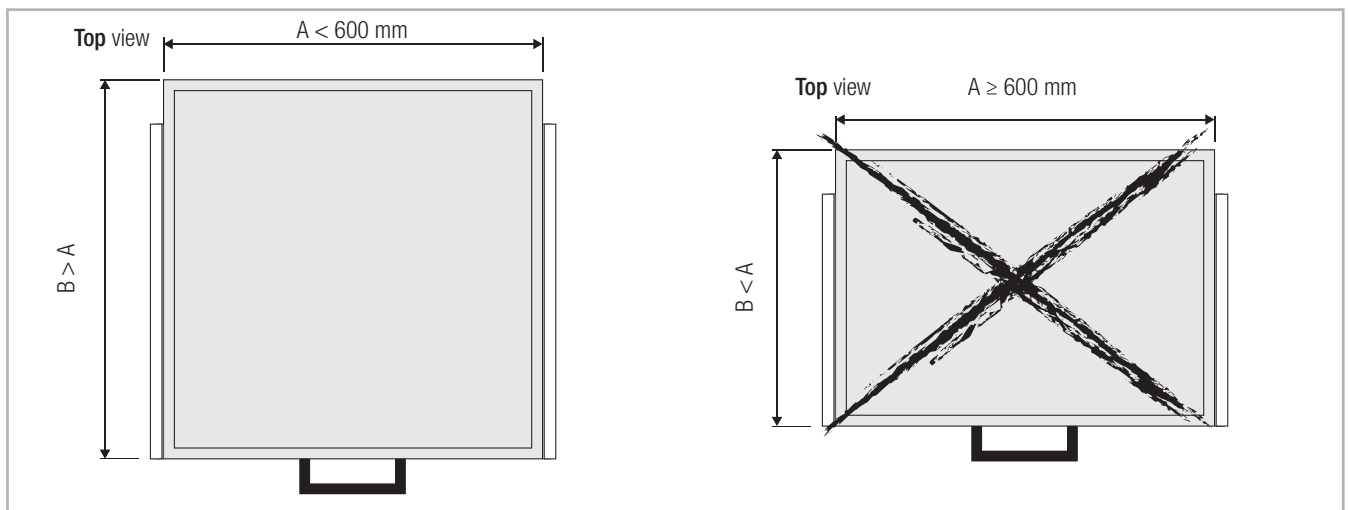
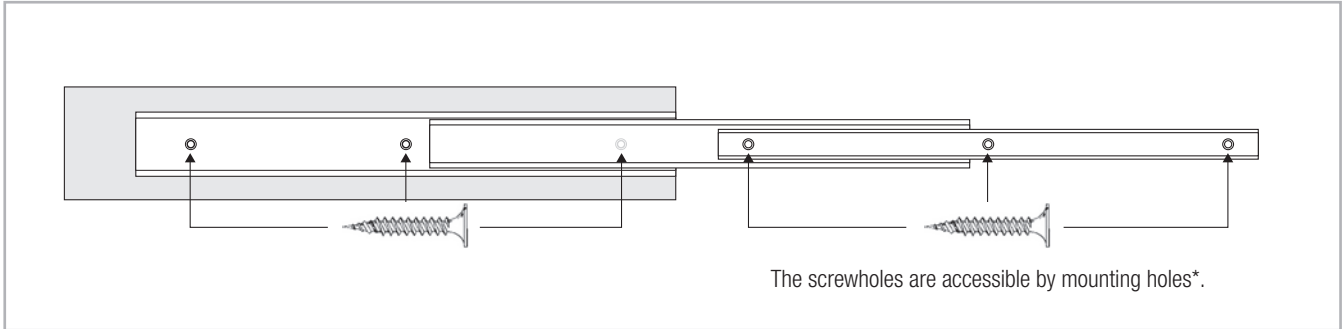

Fig. 23

> Fixations

The rails can be mounted using a wide variety of fixations such as screw holes, mounting tabs, hanging tabs, press-in bolts, etc. When selecting screws, make sure the screw head does not protrude, so there is no contact between the moving parts of the rail and the screw head.



*the number of screws may vary depending on the length of the rail

Fig. 24

Type	Size	Screw type	
		Moving element	Fixed element
LRS	37	Metal: M4 / DIN 965 / ISO 7046 M4 / DIN 7500 Wood: 4,5 / DIN 7997	Metal: M4 / DIN 7984 M4 / M5 / ISO 7380 Wood: 5,0 / DIN 7997
LFS	46	M4 DIN 965 / UNI 7688	M4 DIN 965 / UNI 7688
LRS	56	Metal: M4 / DIN 965 / ISO 7046 M4 / DIN 7500 M4 / DIN 7991 / ISO 10462 Wood: 4,0 / 4,5 / DIN 7997	Metal: M5 / DIN 965 / ISO 7046 M5 / DIN 7500 Wood: 5,0 / DIN 7997
	71	Metal: M4 / DIN 965 / ISO 7046 M4 / DIN 7500 Wood: 4,0 / 4,5 / DIN 7997	Metal: M5 / DIN 965 / ISO 7046 M5 / DIN 7500 Wood: 5,0 / DIN 7997
	76	Metal: M5 / DIN 7984 M5 / M6 / ISO 7380	Metal: M5 / DIN 7984 M5 / M6 / ISO 7380
LRS	710E	Metal: M5 / DIN 965 / ISO 7046 M4 / DIN 7500 M4 / DIN 7991 / ISO 10462 Wood: 4,0 / 4,5 / DIN 7997	Metal: M5 / DIN 965 / ISO 7046 M4 / DIN 7500 Wood: 5,0 / DIN 7997

Tab. 7

> Load capacity

Load capacities are specified per pair and are purely indicative. Length, application and construction of the enclosure all have an impact on the load capacity. We recommend testing based on a prototype of the final application. Only then can the proper operation, service life and safety of the application be ensured.

Static load capacity

Static load means that the load capacity of the rail is based on less than 10.000 cycles per pair.

Dynamic load capacity

Dynamic load means that the load capacity of the rail is based up to 100.000 cycles per pair (50.000 for LFS46 and LRS76). The number of

cycles affects the service life and performance. Other factors that may affect performance are:

1. A uniformly or unevenly distributed load
2. Centre of gravity of the load
3. The speed and/or frequency of the movement
4. The length of the rail relative to the extended length
5. The force with which the load comes against the end stop
6. For optimum performance, the rails must be regularly fully extended
7. In case of use in outdoor applications or aggressive environments, please contact our Technical Department.

> Abnormal loads / vibrations

Transport, misuse and shock loads – even of short duration – may cause damage. Excessive or continuous vibration can also reduce the performance and service life of the rails.

> Anticorrosion treatments

The rails have a corrosion-resistant, zinc-plated, blue-passivated finish. High humidity, salts or other chemical agents may damage the surface of metal or plastic components. Exposure to any such conditions should be avoided at all times. For more information please contact Rollon technical support.

> Lubrication

To ensure optimum performance, Rollon applies grease/lubricant to the rails. Contaminants such as grime, grindings, sawdust, paint, etc. may reduce the effectiveness of the applied grease. For more information please contact our Technical Department.

> Speed

The extension speed is determined by the size of the intermediate elements. Therefore, the maximum extension speed is inversely proportional to the overall extension of the rails (see fig. 25). The maximum extension speed is also directly related to the applied load and operating time. The indicated data refers to continuous operation at the maximum load capacity.

> Temperature

Continual operating temperature is -20°C to $+80^{\circ}\text{C}$ for LRS and $+10^{\circ}\text{C}$ to $+40^{\circ}\text{C}$ for LFS. The temperature range may vary according to the application (duration of exposure, impact, other forces on the rail, etc). Please contact our Technical Department.

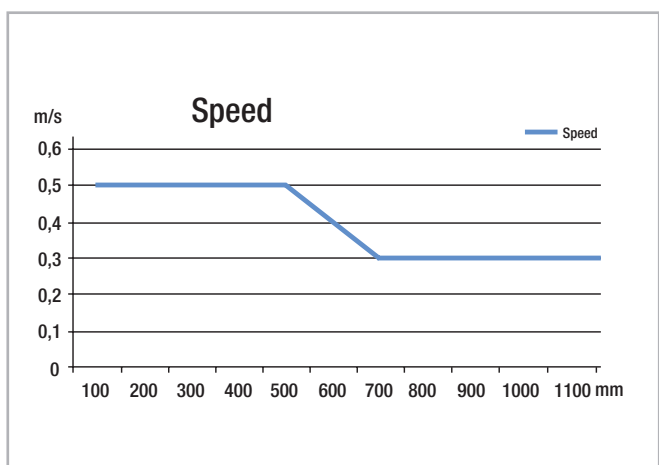

Fig. 25

> Installation instructions

- The existing internal stops are not designed to stop the moving load. They are only supposed to retain the ball-cage and prevent the internal parts to slide out of the assembly. An external end-stop must always be installed to stop the moving load.
- The rails perform best when mounted in a very rigid construction (furniture, device or installation). Do not use the rails as a structural part of a construction.
- To achieve optimum running properties, high service life and rigidity, it is necessary to fix the Light Rail extensions with all accessible holes on a rigid and level surface. Please observe the parallelism of the installation surfaces. The fixed and movable rails fit to the rigid assembly construction.
- Light Rail full and partial extensions are suitable for use in automatic systems. For this, the stroke should remain constant in all moving cycles and the extension speed must be checked (see pg. LR-16, fig.25). The movement of the extensions is enabled by internal ball cages, which could experience an offset from the original position with differing strokes. This phase offset can have a negative effect on the running properties or limit the stroke. If differing strokes occur in an application, the drive force must be sufficiently dimensioned in order to appropriately synchronize the ball cage offset. As an alternative, an extra full stroke cycle can be performed every certain number of cycles, in order to re-phase the ball cage in its correct position.

Ordering key

> Light Rail

LRS	71-	400	
		Rail length in mm	<i>see from pg. LR-6</i>
	Size	<i>see from pg. LR-6</i>	
Rail type	<i>see from pg. LR-6</i>		

Ordering example: LRS71-0400

Notes on ordering: The rail lengths are always indicated as 4 digits with 0 prefixes

Notes 

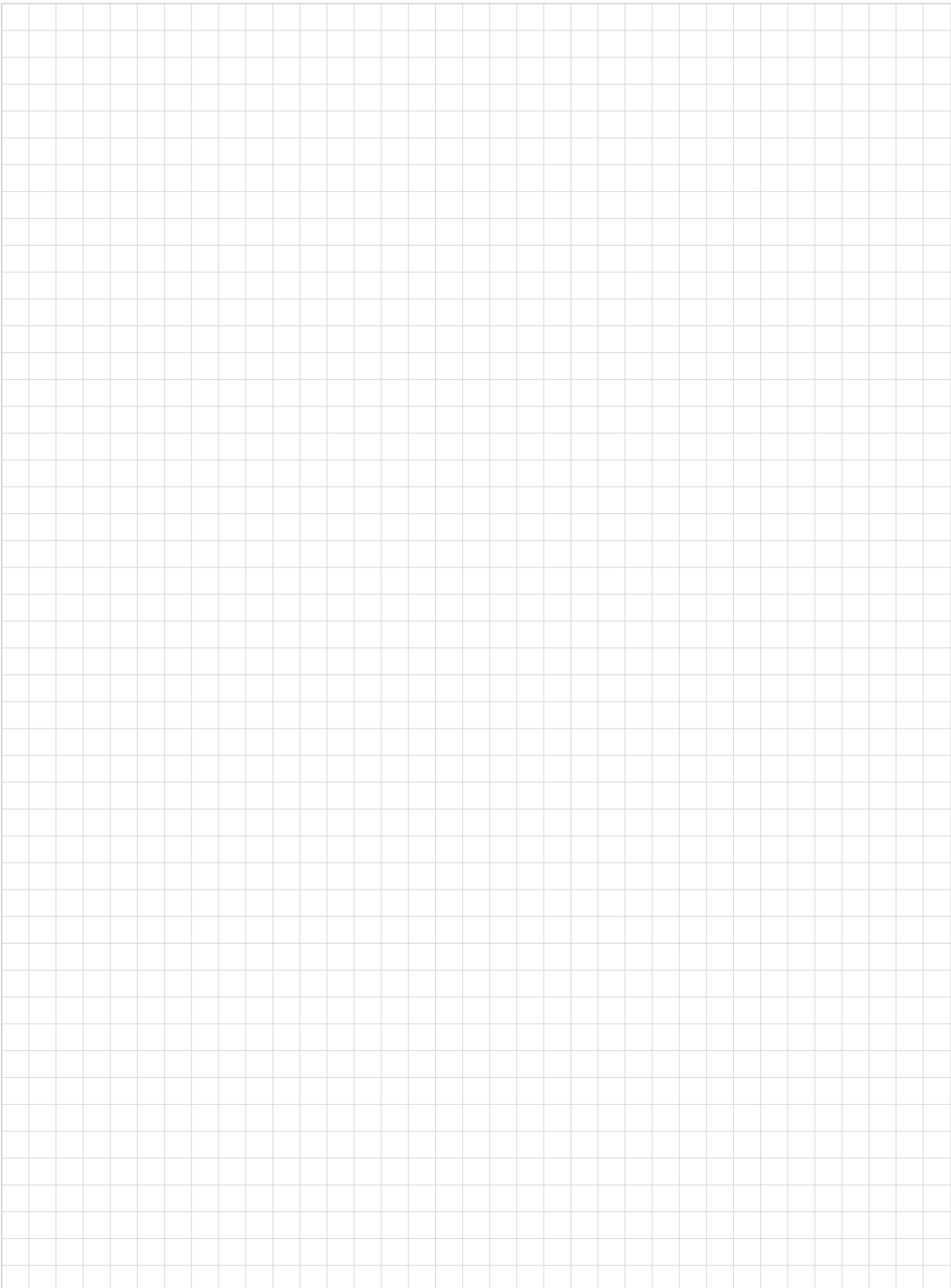

Notes 

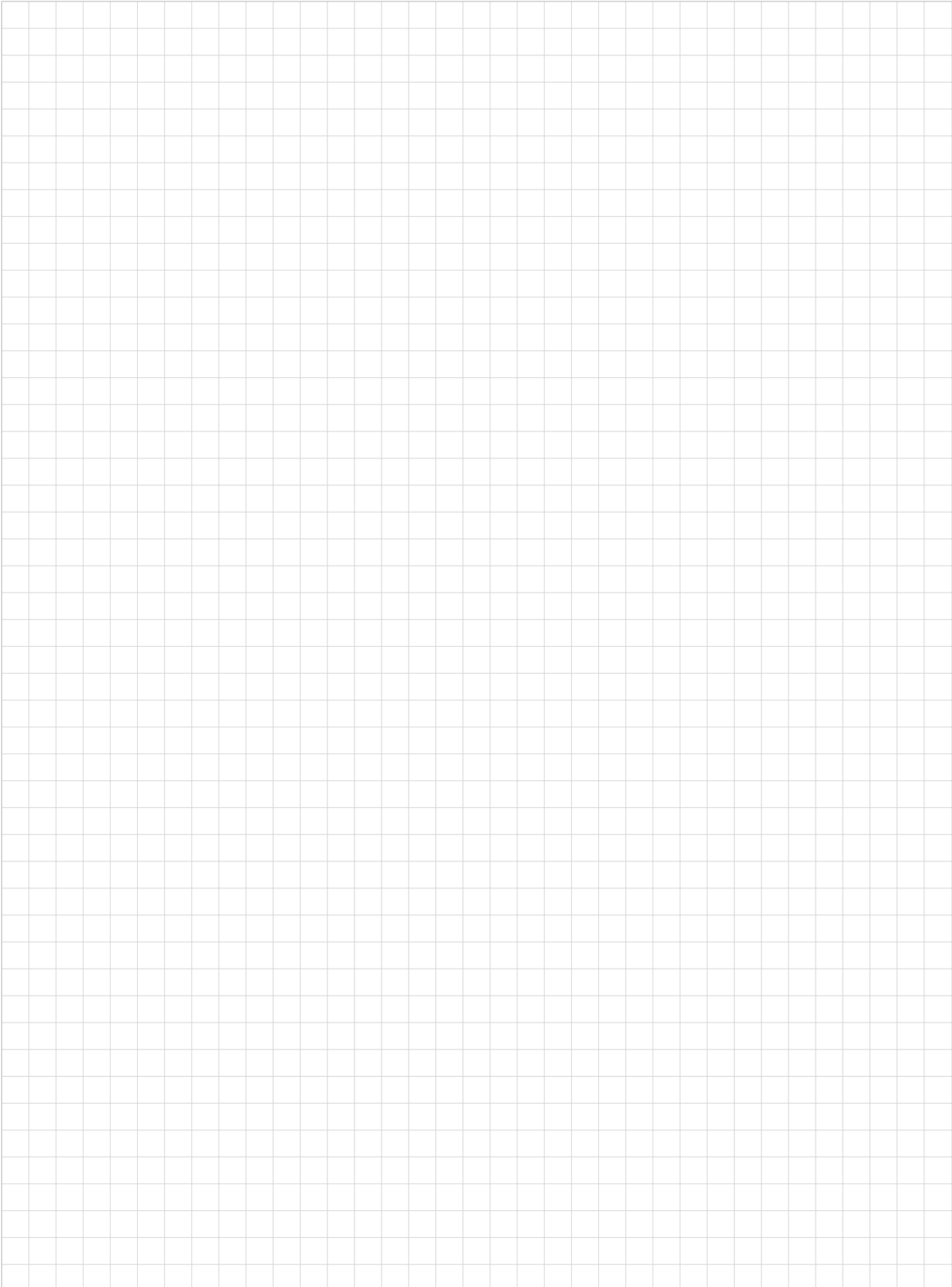

Guides suitable for all applications



Railway

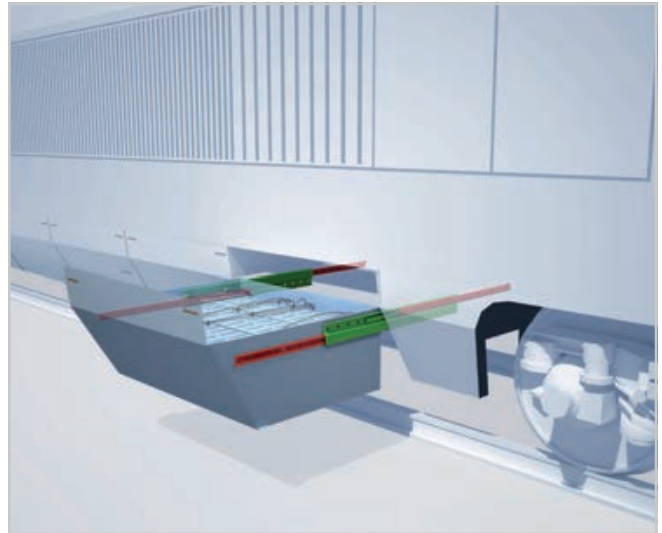
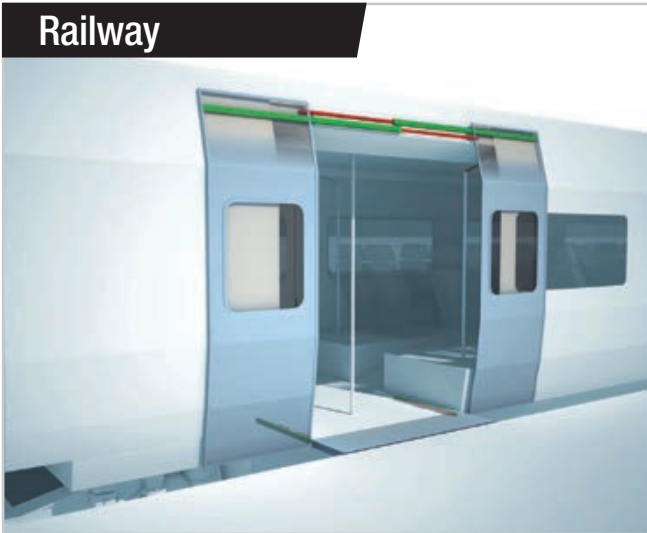

Medical

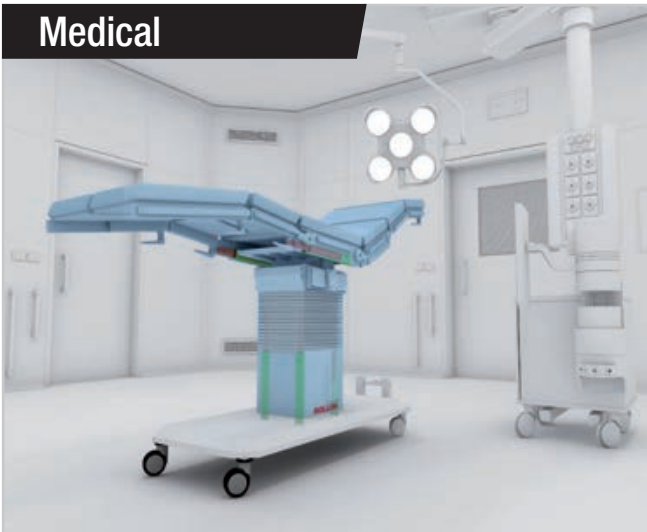

Logistics

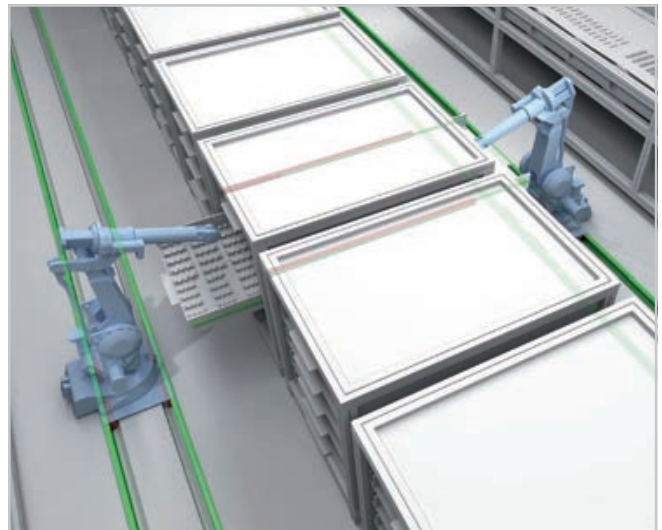

Aerospace



Special Vehicles



Industrial



TO SUPPORT YOU, WE DESIGN AND PRODUCE

Rollon's goal is to support you become **more competitive in your markets**, through technological solutions, design simplification, productivity, reliability, duration, and low maintenance.

We offer everything from **individual components to specifically designed**, mechanically integrated systems: the quality of our applications is an expression of our technology and competence.

ROLLONLAB: EXPERIMENTATION AND INNOVATION

RollonLab, a specialized laboratory where new products created by the R&D department are tested and optimized to perform beyond their technical limits through performance tests and strict quality controls.

RollonLab also tests products in simulations of different application scenarios, to guarantee that the client receives **highly competitive custom products**.

SUPPORT & CUSTOMIZATION

- Product training
- Custom product prototyping
- Application sizing and engineering
- 2D / 3D product drawings on demand
- On-site support for first installation and mock-ups
- Co-design service on sub-systems and full assemblies
- Internal laboratory for static abuse load and endurance tests

Thanks to the experience acquired through years of applications and research, we are able to provide high quality products specifically designed for your needs.



A NEW **DIGITAL EXPERIENCE**
SURROUNDED BY **ROLLON EXPERTS**
WHERE YOU CAN EASILY SELECT
THE PRODUCT **YOU NEED.**

MY.ROLLON.COM

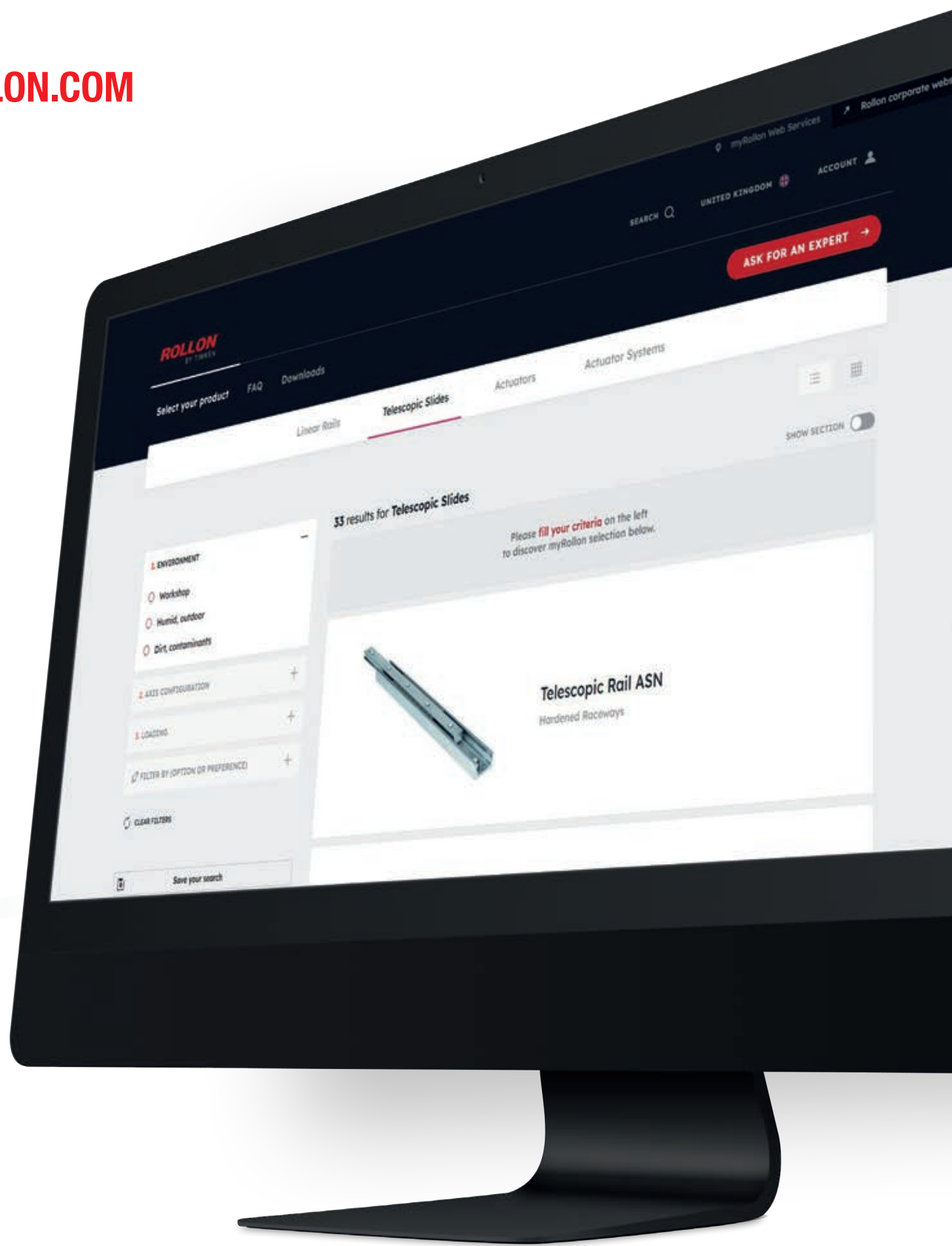



Follow us:



● Rollon Branches & Rep. Offices
● Distributors

ROLLON S.p.A. - ITALY ▼

Via Trieste 26
I-20871 Vimercate (MB)
Phone: (+39) 039 62 59 1
www.rollon.com - infocom@rollon.com

ROLLON GmbH - GERMANY ▼

Bonner Strasse 317-319
D-40589 Düsseldorf
Phone: (+49) 211 95 747 0
www.rollon.de - info@rollon.de

ROLLON S.A.R.L. - FRANCE ▼

Les Jardins d'Eole, 2 allée des Séquoias
F-69760 Limonest
Phone: (+33) (0) 4 74 71 93 30
www.rollon.fr - infocom@rollon.fr

ROLLON Ltd - UK (Rep. Office) ▼

The Works 6 West Street Olney
Buckinghamshire, United Kingdom, MK46 5 HR
Phone: +44 (0) 1234964024
www.rollon.uk.com - ukandireland@rollon.com

AMERICA

ROLLON Corporation - USA ▼

101 Bilby Road. Suite B
Hackettstown, NJ 07840
Phone: (+1) 973 300 5492
www.rollon.com - info@rolloncorp.com

ROLLON - SOUTH AMERICA ▼

101 Bilby Road. Suite B
Hackettstown, NJ 07840
Phone: (+1) 973 300 5492
www.rollon.com - info@rolloncorp.com

ASIA

ROLLON Ltd - CHINA ▼

No. 1155 Pang Jin Road,
China, Suzhou, 215200
Phone: +86 0512 6392 1625
www.rollon.cn.com - info@rollon.cn.com

ROLLON India Pvt. Ltd. - INDIA ▼

39-42, Electronic City, Phase-I,
Hosur Road, Bangalore-560100
www.rollonindia.in - info@rollonindia.in

ROLLON - JAPAN ▼

〒252-0131
神奈川県相模原市緑区西橋本1-21-4
橋本屋ビル
電話番号 : (+81) 042-703-4101
www.rollon.jp - info@rollon.jp

Consult the other ranges of products

Distributor

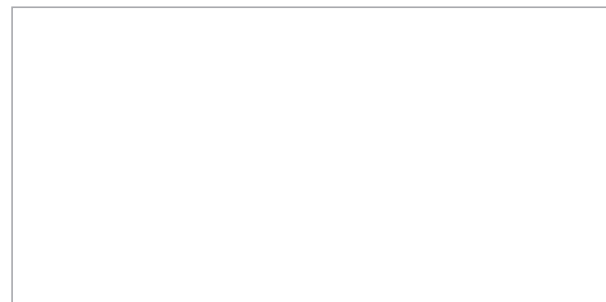

All addresses of our global sales partners can also be found at www.rollon.com

The content of this document and its use are subject to the general terms of sale of ROLLON available on the web site www.rollon.com
Changes and errors expected. The text and images may be used only with our permission.