



**POWER TRANSMISSION  
FLEXIBLE COUPLINGS**

**HRC**



# HRC

The flexible HRC coupling is a break-through safe claw coupling with a flexible element to provide a torsionally flexible connection of shafts. The flexible element, the coupling star, excels in its wear resistance, its oil, ozone and ageing resistance and its temperature resistance from  $-20^{\circ}\text{C}$  to  $+80^{\circ}\text{C}$ . Thanks to the coupling's flexibility, impacts, rotary vibrations and noises are effectively absorbed. The coupling star is dimensioned such that radial and axial movements between the two halves of the coupling are cancelled out. With the fixed position of the coupling star its deformability in axial direction is free, and so no damaging axial forces can act on the machine bearing even with alternating torque. HRC couplings are fail-safe up to the fracture moment of the cast iron transmission cam and this provides maximum operational safety. The coupling is of the plug-in type for installation and does not involve any particularly rigorous requirements with respect to alignment accuracy. The HRC coupling can be used in the whole of machine construction wherever a reliable shaft connection is needed between motor and working machine.

## WITH TAPER BUSH

The HRC coupling combines the outstanding features of the flexible couplings with the advantages of the taper bush system: fast and easy

installation for a torsionally flexible connection between shafts and elimination of shaft alignment errors. HRC couplings with taper bush have the advantage that even with greater shaft tolerances there is a backlash-free and at the same time axial fixing

of the shaft. In addition the close sliding fit makes axial alignment of the coupling easier. The coupling star can be replaced by a simple axial displacement of the coupling halves without having to disassemble the machines connected.



## TYPE

- > Standard coupling
- > Taper bush type
- > Combined type standard/taper
- > Components can be combined as needed

# TECHNICAL DATA

Size	Max. rotation rpm	Torque <sup>1)</sup> Nm		Torsion spring rigidity Nm/°	Moments of inertia <sup>2)</sup> kgm <sup>2</sup>	Weight <sup>2)</sup>	Max. shaft misalignment <sup>3)</sup>		
		nominal T <sub>KN</sub>	max. T <sub>kmax</sub>				radial Δ K <sub>r</sub> mm	axial Δ K <sub>a</sub> mm	angular Δ K <sub>w</sub> degree
70	8100	31	72	–	0.00085	1.00	0.3	+0.2	1
90	6500	80	180	–	0.00115	1.17	0.3	+0.5	1
110	5200	160	360	65	0.00400	5.00	0.3	+0.6	1
130	4100	315	720	130	0.00780	5.46	0.4	+0.8	1
150	3600	600	1500	175	0.01810	7.11	0.4	+0.9	1
180	3000	950	2350	229	0.04340	16.6	0.4	+1.1	1
230	2600	2000	5000	587	0.12068	26.0	0.5	+1.3	1
280	2200	3150	7200	1025	0.44653	50.0	0.5	+1.7	1

- 1) Torques for shaft fit with keyway
- 2) The information concerning weights and moments of inertia apply for medium holes per coupling; coupling half materials: EN-GJL-250 (GG-25) in accordance with DIN EN 1561.
- 3) The values mentioned are valid for n = 600 rpm and may occur only separately.  
At multiple misalignments or higher speeds the values must be reduced.

HRC

# ALLOWABLE MISALIGNMENTS

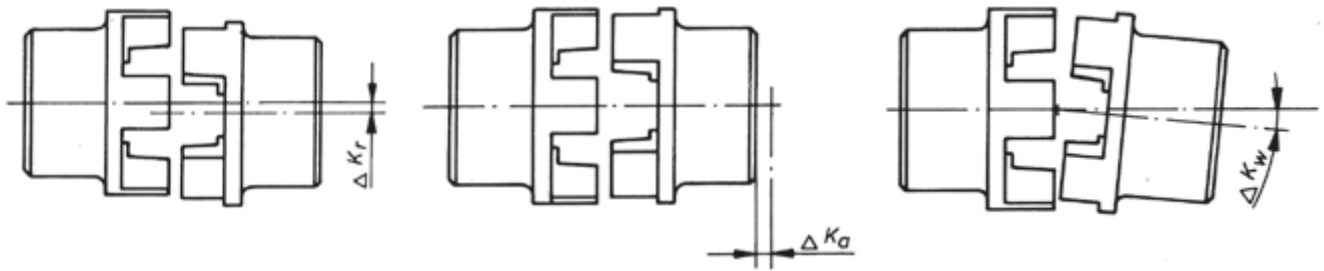

Radial misalignment

Axial misalignment

Angular misalignment

> Reduction of the allowable values of misalignment when the combination of misalignments occur or at other rotational speeds:

$$\frac{\Delta W_r}{\Delta K_r} + \frac{\Delta W_a}{\Delta K_a} + \frac{\Delta W_w}{\Delta K_w} \leq 1$$

< 1 = applies to speeds of 600 rpm  
 ≤ 0.8                    601 – 1000 rpm  
 ≤ 0.65                   1001 – 1500 rpm  
 ≤ 0.50                   1501 – 3000 rpm

Δ K<sub>r/a/w</sub> = allowable radial, axial or angular misalignment of the shafts resp. of the coupling halves

Δ W<sub>r/a/w</sub> = measured radial, axial or angular misalignment of the shafts resp. of the coupling halves

# HRC FLANGE B, F, H

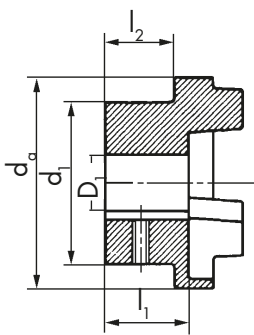
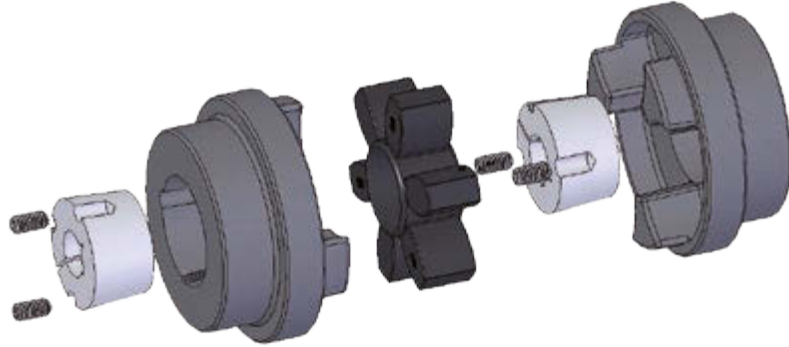

B flange

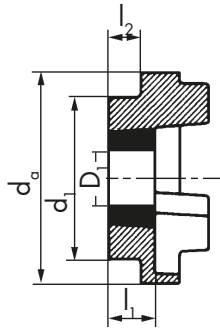

F flange

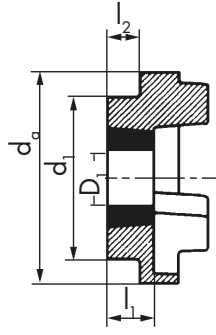

H flange

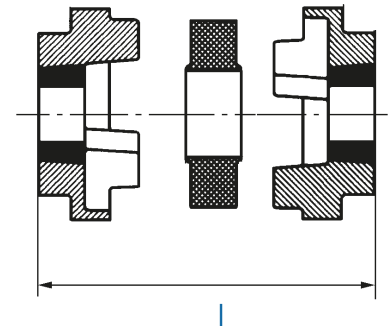

l

Size	B flange				F and H flange					d <sub>o</sub> mm	d <sub>i</sub> mm	Installation length		
	pre. mm	D <sub>1</sub> (H7) <sup>1)</sup> max. mm	l <sub>1</sub> mm	l <sub>2</sub> mm	bush	D <sub>1</sub>		l <sub>1</sub> mm	l <sub>2</sub> mm			l		
						min. mm	max. mm					FF FH HH mm	FB HB mm	BB mm
70	8	32	23.5	20	1008	10	25	23.5	20	69	60	65	65	65
90	10	42	30.0	26	1108	10	25	23.5	19.5	85	70	69.5	76	82.5
110	10	55	45.0	37	1610	14	40	26.5	18.5	112	100	82	100.5	119
130	15	60	47.5	39	1610	14	40	26.5	18.0	130	105	89	118	147
150	20	70	56.0	46	2012	14	50	33.5	23.5	150	115	107	133.5	160
180	25	80	70.0	58	2517	16	60	46.5	34.5	180	125	142	165.5	189
230	25	100	90.0	77	3020	25	75	52.5	39.5	225	155	164.5	202	239.5
280	30	115	105.5	90	3525	35	100	66.5	51.0	275	206	207.5	246.5	285.5

1) Drill holes H7 with keyway in accordance with DIN 6885/1; tolerance zone JS9 and set screws on the keyway

# TAPER BUSHES

## WITH KEYWAY ACC. TO DIN 6885/1

### TOLERANCE JS9

Taper bush no.	Bore ø of available Taper bushes											
	mm											
1008	10	11	12	14	16	18	19	20	22	24	25	
1108	10	11	12	14	16	18	19	20	22	24	25	28*
1610/1615	14	16	18	19	20	22	24	25	28	30	32	35
	38	40	42*									
2012	14	16	18	19	20	22	24	25	28	30	32	35
	38	40	42	45	48	50						
2517	16	18	19	20	22	24	25	28	30	32	35	38
	40	42	45	48	50	55	60					
3020	25	28	30	32	35	38	40	42	45	48	50	55
	60	65	70	75								
3525	35	38	40	42	45	48	50	55	60	65	70	75
	80	85	90	95	100							

\* These bore holes are with flat keyway in accordance with DIN 6885/3.

## SELECTION

The torque of the machine  $T_{AN}$  is determined by:  $T_{AN} [\text{Nm}] = 9550 \times \frac{P_{\text{Motor}} [\text{kW}]}{n [\text{rpm}]}$

This torque  $T_{AN}$  multiplied by a safety factor  $S$  depending on the application and the temperature factor  $S_T$  (see table page 7) gives the required nominal coupling torque  $T_{KN}$ .

Result:  $T_{KN} \geq S \times S_T \times T_{AN}$

► In case that bigger shock or changing loads occur we recommend a revision according to DIN 740. An adequate calculation program is available. For such a revision the following information is required:

1. Kind of the driving machine
2. Kind of the driven machine
3. Power of driving and driven machines
4. Rotational speed of operation
5. Shock loads
6. Exciting loads
7. Moments of inertia of load- and driving sides
8. Starts per hour
9. Ambient temperature

## DESIGN EXAMPLE FOR IEC STANDARD MOTORS

### Dates of the plant

Driving machine:  
 Three-phase motor: 225 M  
 Power of the motor: P = 45 kW  
 Rotation at speed: n = 1500 rpm  
 Driven machine: mixer  
 Ambient temperature: +50 °C

$$T_{AN} [\text{Nm}] = 9550 \times \frac{45 \text{ kW}}{1500 \text{ rpm}} = 287 \text{ Nm}$$

$$T_{KN} = 1.75 \times 1.5 \times 287 \text{ Nm} = 753 \text{ Nm}$$

Selection: HRC size 180

$$T_{KN} = 950 \text{ Nm}$$

# ALLOCATION TO IEC MOTORS

Power P of the IEC motors and allocated HRC couplings									Shaft ends	
Size of the three-phase motor	3000 rpm		1500 rpm		1000 rpm		750 rpm		Form E DIN 748 part 3 d x l at speed approx.	
	P kw	HRC size	P kw	HRC size	P kw	HRC size	P kw	HRC size	3000 rpm	1500 rpm and less
<b>56</b>	0.09	70	0.06	70	0.037	70	–		9 x 20	
	0.12	70	0.09	70	0.045	70	–			
<b>63</b>	0.18	70	0.12	70	0.06	70	–		11 x 23	
	0.25	70	0.18	70	0.09	70	–			
<b>71</b>	0.37	70	0.25	70	0.18	70	0.09	70	14 x 30	
	0.55	70	0.37	70	0.25	70	0.12	70		
<b>80</b>	0.75	70	0.55	70	0.37	70	0.18	70	19 x 40	
	1.1	70	0.75	70	0.55	70	0.25	70		
<b>90 S</b>	1.5	70	1.1	70	0.75	70	0.37	70	24 x 50	
<b>90 L</b>	2.2	70	1.5	70	1.1	70	0.55	70	24 x 50	
<b>100 L</b>	3	90	2.2	90	1.5	90	0.75	90	28 x 60	
	–	–	3	90	–	–	1.1	90		
<b>112 M</b>	4	90	4	90	2.2	90	1.5	90	28 x 60	
<b>132 S</b>	5.5	110	5.5	110	3	110	2.2	110	38 x 80	
	7.5	110	–	–	–	–	–	–		
<b>132 M</b>	–	–	7.5	110	4	110	3	110	38 x 80	
	–	–	–	–	5.5	110	–	–		
<b>160 M</b>	11	130	11	130	7.5	130	4	130	42 x 110	
	15	130	–	–	–	–	5.5	130		
<b>160 L</b>	18.5	130	15	130	11	130	7.5	130	42 x 110	
<b>180 M</b>	22	130	18.5	130	–	–	–	–	48 x 110	
<b>180 L</b>	–	–	22	130	15	130	11	130	48 x 110	
<b>200 L</b>	30	150	30	150	18.5	150	15	150	55 x 110	
	37	150	–	–	22	150	–	–		
<b>225 S</b>	–	–	37	150	–	–	18.5	150	55 x 110	60 x 140
<b>225 M</b>	45	150	45	150	30	150	22	150	55 x 110	60 x 140
<b>250 M</b>	55	150	55	180	37	180	30	180	60 x 140	65 x 140
<b>280 S</b>	75	180	75	230	45	230	37	230	65 x 140	75 x 140
<b>280 M</b>	90	180	90	230	55	230	45	230	65 x 140	75 x 140
<b>315 S</b>	110	180	110	280	75	280	55	280	65 x 140	80 x 170
<b>315 M</b>	132	180	132	280	90	280	75	280	65 x 140	80 x 170
<b>315 L</b>	160	230	160	280	110	280	90	280	65 x 140	80 x 170
	200	230	200	280	132	280	110	280	–	–
<b>355 L</b>	250	230	250	280	160	280	132	–	–	–
	315	230	315	–	200	–	160	–	75 x 140	95 x 170
<b>400 L</b>	–	–	–	–	250	–	200	–	–	–
	355	280	355	–	315	–	250	–	80 x 170	100 x 210
	400	280	400	–	–	–	–	–	–	–

As proposed in the table for surface cooled three-phase motors with cage rotor acc. to DIN 42673, page 1 (data for motor 56, 63, 71, 80, 315 L, 355 L, 400 L, see catalogue Siemens). This allocation is a preliminary selection for normal conditions of operation. For conditions of operation under shock and changing loads the selection must be made according to the following.

## SAFETY FACTOR S

Assignment of load characteristics according to type of working machine					
<b>S</b>	<b>DREDGERS</b>	<b>S</b>	<b>RUBBER MACHINERY</b>	<b>S</b>	<b>PUMPS</b>
<b>S</b>	Bucket conveyor	<b>S</b>	Extruders	<b>G</b>	Piston pumps
<b>M</b>	Landing gear (caterpillar)	<b>M</b>	Calenders	<b>M</b>	Centrifugal pumps (light liquids)
<b>M</b>	Landing gear (rail)	<b>S</b>	Kneading mills	<b>S</b>	Centrifugal pumps (viscous liquids)
<b>M</b>	Manoeuvring winches	<b>M</b>	Mixers	<b>S</b>	Plunger pumps
<b>M</b>	Pumps	<b>S</b>	Rolling mills	<b>S</b>	Press pumps
<b>S</b>	Impellers				
<b>S</b>	Cutter heads		<b>WOOD WORKING MACHINES</b>		<b>STONE AND CLAY WORKING MACHINES</b>
<b>M</b>	Slewing gear	<b>S</b>	Barkers	<b>S</b>	Crusher
		<b>M</b>	Planing machines	<b>S</b>	Rotary ovens
<b>M</b>	<b>GENERATORS, TRANSFORMERS</b>	<b>G</b>	Wood working machines	<b>S</b>	Hammer mills
<b>M</b>	Frequency transformers	<b>S</b>	Saw frames	<b>S</b>	Ball mills
<b>M</b>	Generators			<b>S</b>	Tube mills
<b>M</b>	Welding generators			<b>S</b>	Beater mills
				<b>S</b>	Brick presses
	<b>CHEMICAL INDUSTRY</b>		<b>CRANES</b>		<b>TEXTILE MACHINES</b>
<b>M</b>	Cooling drums	<b>G</b>	Luffing gear block	<b>M</b>	Batchers
<b>M</b>	Mixers	<b>S</b>	Travelling gear	<b>M</b>	Printing and dyeing machines
<b>G</b>	Agitators (liquid material)	<b>G</b>	Hoist gear	<b>M</b>	Tanning vats
<b>M</b>	Agitators (semi-liquid material)	<b>M</b>	Slewing gear	<b>M</b>	Willows
<b>M</b>	Drying drums	<b>M</b>	Derricking jib gear	<b>M</b>	Looms
<b>G</b>	Centrifuges (light)				<b>COMPRESSORS</b>
<b>M</b>	Centrifuges (heavy)	<b>M</b>	<b>PLASTIC INDUSTRY MACHINES</b>	<b>S</b>	Piston compressors
		<b>M</b>	Extruders	<b>M</b>	Turbo compressors
<b>M</b>	<b>OIL INDUSTRY</b>	<b>M</b>	Calenders		
<b>S</b>	Pipeline pumps	<b>M</b>	Mixers		
	Rotary drilling equipment	<b>M</b>	Crushers		
					<b>METAL ROLLING MILLS</b>
<b>M</b>	<b>CONVEYORS</b>	<b>M</b>	<b>METAL WORKING MACHINES</b>	<b>S</b>	Plate shears
<b>S</b>	Pit-head winches	<b>S</b>	Plate bending machines	<b>M</b>	Manipulator for turning sheets
<b>M</b>	Winding engines	<b>S</b>	Plate straightening machines	<b>S</b>	Ingot pushers
<b>M</b>	Jointed-band conveyors	<b>S</b>	Hammers	<b>S</b>	Ingot and slabbing-mill train
<b>G</b>	Belt conveyors (bulk material)	<b>S</b>	Metal planning machines	<b>S</b>	Ingot handling machinery
<b>M</b>	Belt conveyors (piece goods)	<b>M</b>	Presses	<b>M</b>	Wire drawing benches
<b>M</b>	Band pocket conveyors	<b>S</b>	Shears	<b>S</b>	Descaling machines
<b>M</b>	Chain conveyors	<b>S</b>	Forging presses	<b>S</b>	Thin plate mills
<b>M</b>	Circular conveyors	<b>S</b>	Punch presses	<b>S</b>	Heavy and medium plate mills
<b>M</b>	Load elevators	<b>G</b>	Countershafts, line shafts	<b>M</b>	Winding machines (strip and wire)
<b>G</b>	Bucket conveyors for flour	<b>M</b>	Machine tools (main drives)	<b>S</b>	Cold rolling mills
<b>M</b>	Passenger lifts	<b>G</b>	Machine tools (auxiliary drives)	<b>M</b>	Chain tractor
<b>M</b>	Plate conveyors			<b>S</b>	Billet shears
<b>M</b>	Screw conveyors	<b>G</b>	<b>FOOD INDUSTRY MACHINERY</b>	<b>M</b>	Cooling beds
<b>M</b>	Ballast elevators	<b>M</b>	Bottling and container filling machines	<b>M</b>	Cross tractor
<b>S</b>	Inclined hoists	<b>M</b>	Kneading machines	<b>M</b>	Roller tables (light)
<b>M</b>	Steel belt conveyors	<b>M</b>	Mash tubs	<b>S</b>	Roller tables (heavy)
<b>M</b>	Drag chain conveyors	<b>S</b>	Packaging machines	<b>M</b>	Roller straighteners
		<b>M</b>	Cane crushers	<b>S</b>	Tube welding machines
		<b>M</b>	Cane cutters	<b>M</b>	Trimming shears
		<b>S</b>	Cane mills	<b>S</b>	Cropping shears
		<b>M</b>	Sugar beet cutters	<b>S</b>	Continuous casting plant
		<b>M</b>	Sugar beet washing machines	<b>M</b>	Rollers adjustment drive
				<b>S</b>	Manipulators
<b>M</b>	<b>BLOWERS, VENTILATORS</b>				<b>LAUNDRIES</b>
<b>G</b>	Rotary piston blowers		<b>PAPER MACHINES</b>	<b>M</b>	Tumblers
<b>M</b>	Blowers (axial/radial)	<b>S</b>	Couches	<b>M</b>	Washing machines
<b>M</b>	Cooling tower fans	<b>S</b>	Glazing cylinders		
<b>M</b>	Induced draught fans	<b>M</b>	Pulper		
<b>G</b>	Turbo blowers	<b>S</b>	Pulp grinders		
		<b>M</b>	Calenders		
<b>S</b>	<b>BUILDING MACHINERY</b>	<b>S</b>	Wet presses		
<b>G</b>	Hoists	<b>S</b>	Willows		
<b>S</b>	Concrete mixers	<b>S</b>	Suction presses		
	Road construction machinery	<b>S</b>	Suction rolls		
		<b>S</b>	Drying cylinders		

HRC

Driving machines	Operating factor S			Temperature factor S <sub>T</sub>	
	G	M	S	ϑ [°C]	S <sub>T</sub>
Electric motors, turbines, hydraulic motors	1	1.75	2.5	-20 < ϑ < +30	1.0
Piston machines 4–6 cylinders, degree of nonuniformity 1:100 – 1:200	1.5	2.5	3.5	+30 < ϑ < +40	1.2
Piston machines 1–3 cylinders, degree of nonuniformity up to 1:100	2	3	4	+40 < ϑ < +60	1.5
				+60 < ϑ < +80	1.8