



Vacuum Automation

# Components Catalog

Edition 14

[WWW.SCHMALZ.COM/AUTOMATION](http://WWW.SCHMALZ.COM/AUTOMATION)

## Your Personal Account With Order Center & Useful Information

### Find and Select Products

Use selection aids and filters to quickly find your product. Save it in your personal bookmarks for a later usage.

### Get and Compare Information

Compare multiple products, download CAD data, check prices and availability.

### Place and Track Your Order

Place your order with only one mouseclick, get tracking information and generate follow-up orders.

### Online Services

Find information like how-to videos, Schmalz calculator & tutorials on [WWW.SCHMALZ.COM/ONLINE-SERVICES](http://WWW.SCHMALZ.COM/ONLINE-SERVICES)

### Selection Aids and Filters

Useful tools to select products and to make your decision easier.



Trusted Shop certified  
in European countries



**Schmalz Online Shop**  
**WWW.SCHMALZ.COM**

# Contents

		Page		
	<b>Schmalz – The Company</b>	Company Profile · Efficiency and Sustainability · Business Units · Industry Solutions	4	Schmalz – The Company
	<b>Vacuum Suction Cups</b>	Universal Suction Cups · Suction Cups for Special Applications (Metal, Wood, Packaging etc.)	24	Vacuum Suction Cups
	<b>Special Grippers</b>	Floating Suction Cups · Magnetic Grippers · Thin Glass Grippers · Needle Grippers · Wafer Grippers · Flow Grippers	238	Special Grippers
	<b>Vacuum Gripping Systems</b>	Vacuum Area Gripping Systems · Vacuum End Effectors	288	Gripping Systems
	<b>Vacuum Clamping Systems</b>	Systems for Metal and Plastic Processing · Systems for Glass Processing · 3D Clamping Systems	332	Clamping Systems
	<b>Mounting Elements</b>	Jointed Mountings · Spring Plungers · Holders · Sections and Connectors	348	Mounting Elements
	<b>Vacuum Generators</b>	Ejectors · Pumps · Blowers · Vacuum Unit · Operation Center	412	Vacuum Generators
	<b>Valve Technology</b>	Solenoid Valves · Check Valves · Touch Valves · Non-Return Valves · Manual Valves	558	Valve Technology
	<b>Switches and System Monitoring</b>	Mechanic Vacuum Switches · Vacuum Sensors · Electronic Vacuum/Pressure Switches · Measuring and Control Devices	598	Switches and Monitoring
	<b>Filters and Connections</b>	Vacuum Filters · Distributors · Hoses and Connectors · Accessories	634	Filters and Connections
	<b>Services</b>	Services · Test Center · Test Sets · Schmalz Academy	669	Services
	<b>Contact</b>	Website · International Sales Network · Imprint	675	Contact
	<b>Glossary</b>	Vacuum Dictionary · Technical Terms	679	Glossary
<b>A-Z</b>	<b>Index of Products</b>	Products Sorted Alphabetically	683	Index of Products

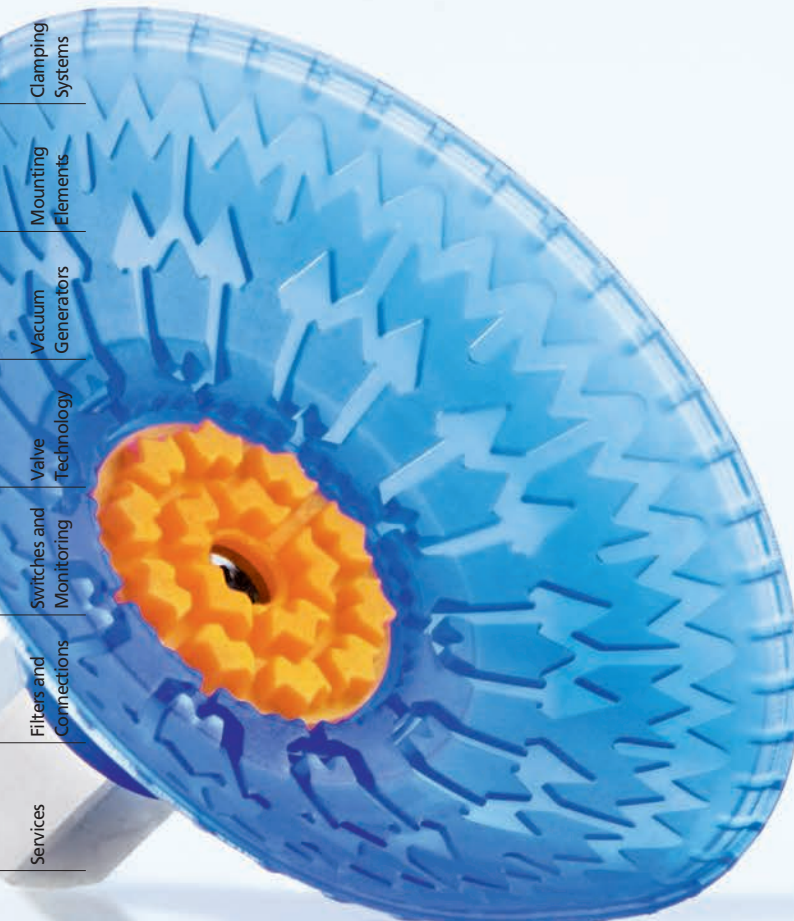



## Schmalz is the market leader in vacuum automation and ergonomic handling systems.

As the market leader in vacuum automation and ergonomic handling solutions, Schmalz is in demand worldwide. With our own locations and our trade partners, we are represented in more than 80 countries and in all of the most important markets – everywhere our customers are. The basis for our success is our passion for innovation, a passion that drives all of our employees. For example, we invest about 8.5 % of our revenue each year into research and development.

The result are impressive solutions that have been setting new standards in the vacuum technology market for decades: Solutions

that stand for energy efficiency and technological advancement. Solutions that are helping to build the digitally networked, intelligent factory of the future, Industry 4.0. With our expert consulting and first-class quality, we offer our customers sustainable value for their processes.

You, too, can engage in a partnership that brings long-term competitive advantages – by placing your trust in Schmalz vacuum technology.

Dr. Dipl.-Ing. Kurt Schmalz  
Managing Director

Andreas Beutel  
Managing Director

Dr. Hinrich Dohrmann  
Managing Director

- Schmalz – The Company
- Vacuum Suction Cups
- Special Grippers
- Gripping Systems
- Clamping Systems
- Mounting Elements
- Vacuum Generators
- Valve Technology
- Switches and Monitoring
- Filters and Connections
- Services
- Contact
- Glossary
- Index of Products

- Schmalz – The Company
- Vacuum Suction Cups
- Special Grippers
- Gripping Systems
- Clamping Systems
- Mounting Elements
- Vacuum Generators
- Valve Technology
- Switches and Monitoring
- Filters and Connections
- Services
- Contact
- Glossary
- Index of Products



# 1.400

EMPLOYEES  
WORLDWIDE

# 1910

FOUNDED BY  
JOHANNES SCHMALZ

# 450

REGISTERED PATENTS  
AND COPYRIGHTS

# 8.5%

OF REVENUE FOR  
RESEARCH & DEVELOPMENT

## Our Portfolio

The vacuum automation business unit includes individual components such as suction cups and vacuum generators as well as complete gripping systems and clamping solutions for holding workpieces, for example in CNC machining centers.

In the handling unit, Schmalz offers innovative handling solutions with vacuum lifters and crane systems for industrial and handicraft applications. Our intelligent solutions make production and logistics processes more flexible and efficient, while also preparing them for the increasing trend toward digitalization.

## Certifications

- DIN ISO 9001 (quality management) since 1994
- DIN ISO 14001 (environmental management) since 1997
- DIN ISO 50001 (energy management) since 2012
- AEO C (authorized economic operator, customs simplifications) since 2012

## Vacuum Automation

## Handling



Components



Systems



Clamping solutions



Vacuum lifters and cranes

# International Sales Network

On-site Expertise in more than 80 Countries



## GERMANY

(Headquarters)

J. Schmalz GmbH  
 Johannes-Schmalz-Str. 1  
 72293 Glatten  
 T: +49 7443 2403-0  
 F: +49 7443 2403-259  
 schmalz@schmalz.de

## AUSTRALIA

Millsom Hoists Pty. Ltd.  
 A Schmalz Company  
 25 Turbo Drive  
 Bayswater North VIC 3153  
 T: +61 3 9215 8800  
 F: +61 3 9720 7879  
 schmalz@schmalz.com.au

## CANADA

Schmalz Vacuum Technology Ltd.  
 14-2900 Argentia Rd.  
 L5N 7X9 Mississauga; Ontario  
 T: +1 905 569 9520  
 F: +1 905 569 8256  
 schmalz@schmalz.ca

## CHINA

Schmalz (Shanghai) Co. Ltd.  
 No. 1 Chunquan Road  
 201210 Pudong, Shanghai  
 T: +86 21 510999 33  
 F: +86 21 503988 82  
 schmalz@schmalz.net.cn

## FINLAND

Oy Schmalz Ab  
 Hakkilankaari 2  
 01380 VANTAA  
 T: +358 10 2312011  
 F: +358 9 85746 94  
 schmalz@schmalz.fi

## FRANCE

Schmalz S.A.S.  
 Le Prométhée  
 65 Avenue du Général de Gaulle  
 77420 Champs-sur-Marne  
 T: +33 1 6473 1730  
 F: +33 1 6006 6371  
 schmalz@schmalz.fr

## INDIA

Schmalz India Pvt. Ltd.  
 EL – 38 'J' Block MIDC  
 Bhosari  
 411026 Pune  
 T: +91 20 4072 5500  
 F: +91 20 4072 5588  
 schmalz@schmalz.co.in

## ITALY

Schmalz S.r.l. a Socio Unico  
 Via delle Americhe 1  
 28100 Novara  
 T: +39 0321 621 510  
 F: +39 0321 621 714  
 schmalz@schmalz.it

## JAPAN

Schmalz K.K.  
 3001-7 Odana-cho  
 Tsuzuki-ku  
 JP-224-0027 Yokohama  
 T: +81 45 565 5150  
 F: +81 45 565 5151  
 schmalz@schmalz.co.jp

## MEXICO

Schmalz S. de R.L. de C.V.  
 Pirineos 500, Bodega 18  
 Parque Industrial Benito Juarez  
 Micro Parque Santiago II  
 76120 Querétaro  
 T: +52 442 209 5218  
 schmalz@schmalz.com.mx

## NETHERLANDS

Schmalz B.V.  
 Generatorstraat 34  
 7556 RC Hengelo  
 T: +31 74 25557 57  
 F: +31 74 25557 58  
 schmalz@schmalz.nl

## POLAND

Schmalz Sp.z.o.o.  
 Ul. Kobaltowa 4, Złotniki  
 62-002 Suchy Las (Poznan)  
 T: +48 22 460 49 72  
 F: +48 22 460 49 79  
 schmalz@schmalz.pl

## RUSSIA

OOO Schmalz  
 Mozhayskoe highway 165, bdg 7  
 121596, Moscow  
 T: +7 495 96712 48  
 F: +7 495 96712 49  
 schmalz@schmalz.ru

## SOUTH KOREA

Schmalz Co. Ltd.  
 1412 O-Biz Tower  
 Beolmal St. 126, Dongan-gu  
 Anyang-si, Gyeonggi-do  
 T: +82 31 816 2403  
 F: +82 31 816 2404  
 schmalz@schmalz.co.kr

## SPAIN

Schmalz S.A.  
 Avda. Ribera de Axpe. 49  
 P.A.E. UDONDO-Edificio B-Nave 2  
 48950 Erandio (Vizcaya)  
 T: +34 94 480 5585  
 F: +34 94 480 7264  
 schmalz@schmalz.es

## SWITZERLAND

Schmalz GmbH  
 Eigentalstrasse 1  
 8309 Nürensdorf  
 T: +41 44 88875 25  
 F: +41 44 88875 29  
 schmalz@schmalz.ch

## TURKEY

Schmalz Vakum  
 San. ve Tic. Ltd. Şti.  
 Aydınlı Mah. Patlayıcı  
 Maddeler Yolu  
 Dumankaya Botanik A-89  
 34953-TUZLA-ISTANBUL  
 T: +90 216 34001 21  
 F: +90 216 34001 24  
 schmalz@schmalz.com.tr

## UNITED STATES

Schmalz Inc.  
 5850 Oak Forest Drive  
 Raleigh, NC 27616  
 T: +1 919 71308 80  
 F: +1 919 71308 83  
 schmalz@schmalz.us

You can find the Schmalz sales partner in your country at: [WWW.SCHMALZ.COM/SALESNETWORK](http://WWW.SCHMALZ.COM/SALESNETWORK)



- Schmalz – The Company
- Vacuum Suction Cups
- Special Grippers
- Gripping Systems
- Clamping Systems
- Mounting Elements
- Vacuum Generators
- Valve Technology
- Switches and Monitoring
- Filters and Connections
- Services
- Contact
- Glossary
- Index of Products

► Photovoltaic collectors on the roof of the production hall and one of many company-owned wind turbines supply Schmalz with green energy.

▼ The production hall is supplied by a highly efficient and fully automated intra-logistics system.



## Efficient and Sustainable Products

Resource-Friendly and Sustainable –  
 Throughout the Entire Product Life Cycle



### RESOURCE-FRIENDLY PRODUCTS

Responsible use of non-renewable resources is one of Schmalz's key corporate goals. Schmalz strives to keep its carbon footprint as small as possible throughout all phases of the product life cycle. The carbon impact of a Schmalz product is therefore significantly less than that of comparable products on the market.

### PRODUCT CREATION

Schmalz pays attention to the carbon footprints of its products from the very beginning, employing the latest design and analysis methods in an earliest stage of the development phase to reduce energy-intensive materials and production processes. Fixed environmental targets such as energy efficiency values are defined in our specification sheets.

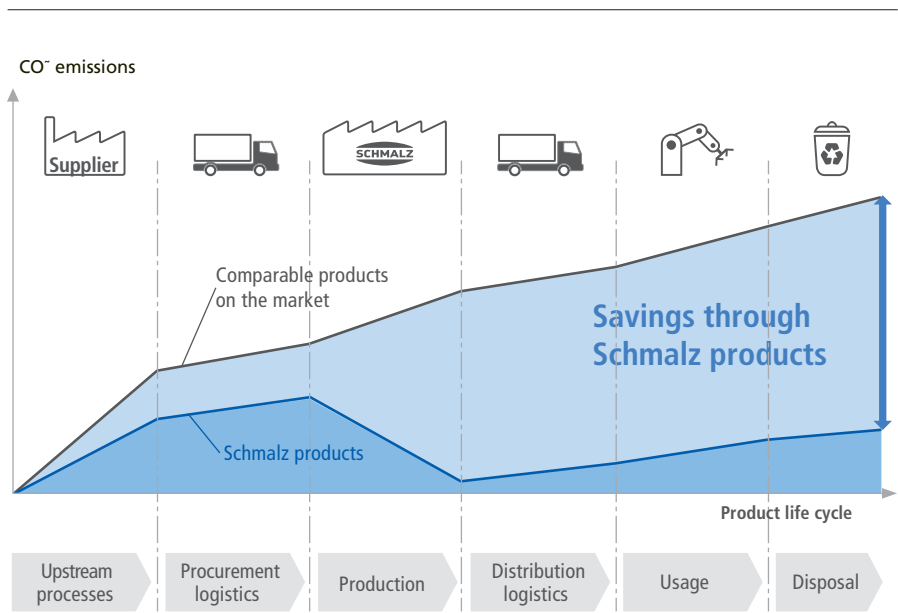

Development of CO<sub>2</sub> emissions during the product life cycle (product carbon footprint)



Example of Product Development for the Basic Ejector SBPL



Previous vacuum generator SEM

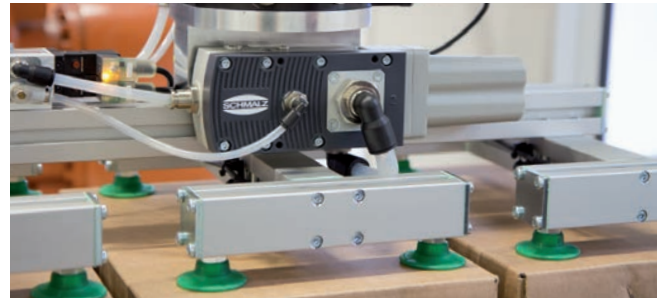

New vacuum generator SBPL

Direct Comparison of Performance Data

	Suction rate at 4.5 bar in l/min	Weight in kg	Air consumption at 4.5 bar in l/min	Sound level in dB	CO2 emissions in kg CO2e*
Vacuum generator SEM	75	1.4	180	80	15.65
Vacuum generator SBPL	100	0.8	160	65	5.41
Savings	33 %	45 %	11 %	19 %	65 %

The SBPL features more power with lower resource consumption and significantly better CO<sub>2</sub> emissions compared to the SEM.

\*CO<sub>2</sub>e includes CO<sub>2</sub> as well as other gases that have been converted to their CO<sub>2</sub> equivalent based on their greenhouse impact.

Also earlier stages in the added-value chain contribute to these targets; thus we train and audit our suppliers. Schmalz relies on regional suppliers with short transport distances. This allows us to purchase parts and assemblies with a low carbon impact. Our carbon-neutral production facility prevents the carbon footprint

from increasing during the manufacturing process. When this is combined with the CO<sub>2</sub> credits achieved by the company as a whole, it even reduces the carbon footprint that Schmalz products have already accumulated. To ship its products, Schmalz uses carbon-neutral shipping methods such as GoGreen shipping from DHL.



Ejector core with eco nozzle technology and integrated automatic air-saving function

EFFICIENCY IN PRODUCT OPERATION

When operating vacuum technology products, it is especially important to use compressed air and electricity resources in an efficient manner. For example, Schmalz designs its compact ejectors so that only the amount of compressed air needed for the actual handling operation is consumed. Energy consumption during downtime is prevented. Using this type of vacuum generator reduces energy consumption by up to 80 %. A gripper for the automated handling of metal sheets equipped with such a generator will save about 730 kg of CO<sub>2</sub> per year.



The design of the recyclable automotive suction cup SAOXM

USING THE PRODUCT AFTER THE UTILIZATION PHASE

To conserve resources at the end of the product cycle, attention is paid to the separability of the individual materials when the product is first created. For example, the elastomer part on special suction cups can easily be separated from the aluminum connection element. Since the elastomer is a part that is subject to wear and tear, it can be replaced without having to purchase a completely new suction cup.

- Schmalz – The Company
- Vacuum Suction Cups
- Special Grippers
- Gripping Systems
- Clamping Systems
- Mounting Elements
- Vacuum Generators
- Valve Technology
- Switches and Monitoring
- Filters and Connections
- Services
- Contact
- Glossary
- Index of Products

Schmalz – The Company
Vacuum Suction Cups
Special Grippers
Gripping Systems
Clamping Systems
Mounting Elements
Vacuum Generators
Valve Technology
Switches and Monitoring
Filters and Connections
Services
Contact
Glossary
Index of Products

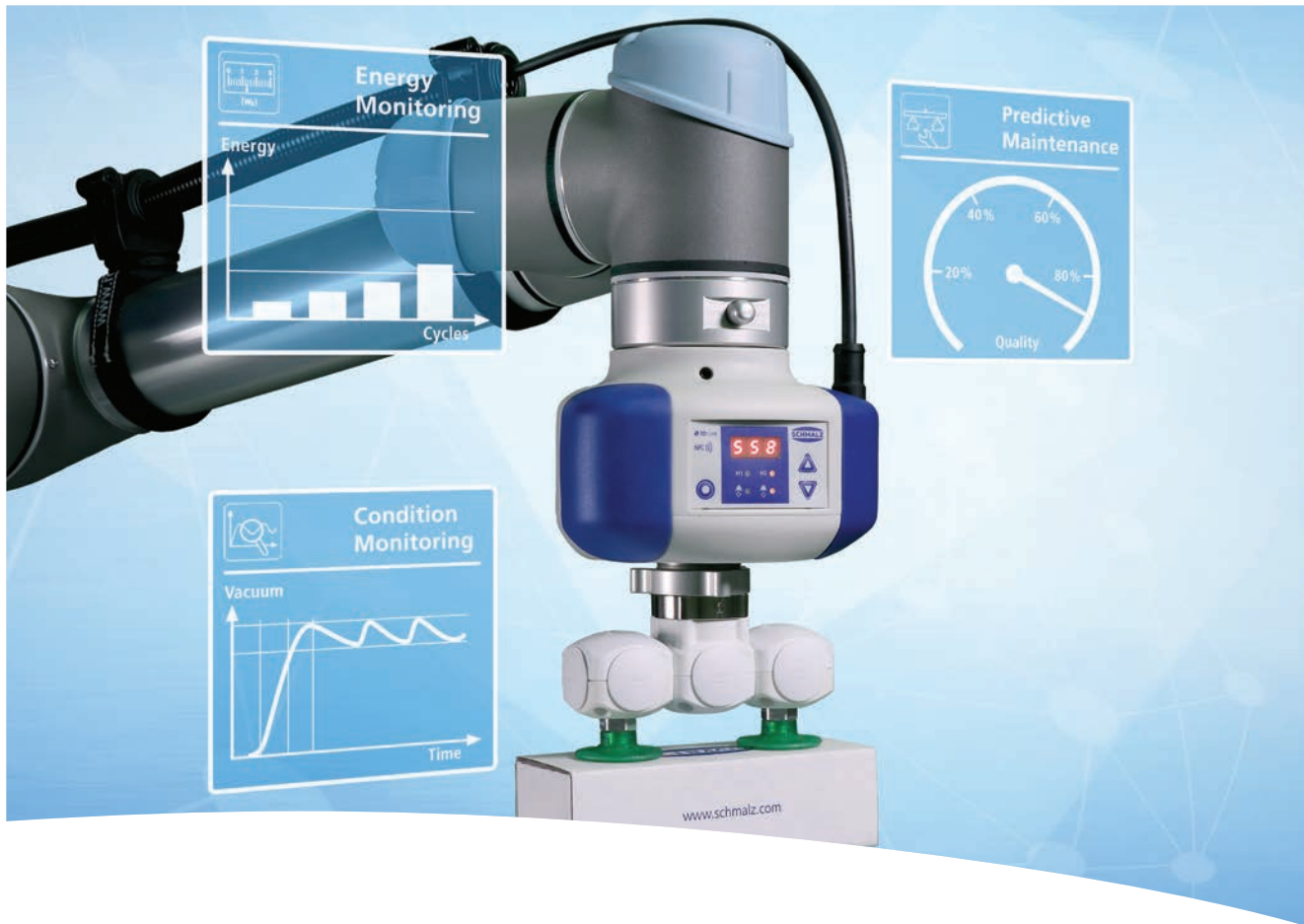

# Vacuum Solutions for Industry 4.0

Intelligent Process Communication for Transparent and Efficient Production

## INTELLIGENT COMMUNICATION WITHIN PRODUCTION

Networking in production means the gradual break-up of hierarchical information structures. An automation cloud is formed in which intelligent devices interact with one another and organize themselves via IO-Link. Intelligent products communicate with the user's systems and adjust all process parameters for energy-optimized operation.

## OUR SMART FIELD DEVICES UNDERSTAND INDUSTRY 4.0

Vacuum generators like the compact ejector SXPi / SXMPi are becoming central to such a cloud. With the aid of their diagnostic and forecasting functions, they derive information regarding the condition of the unit and detect subtle changes or imminent malfunctions. This helps to prevent machine downtime and increase system availability.

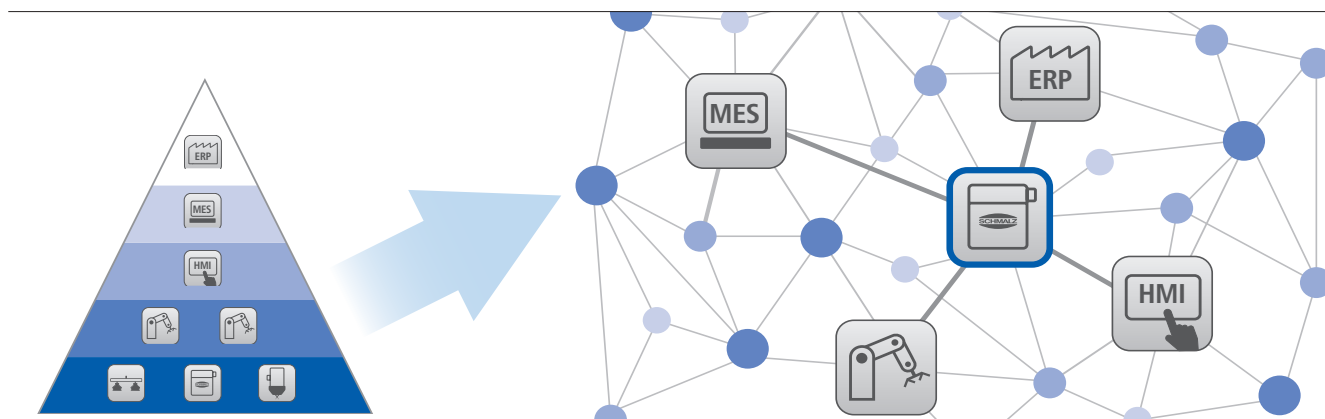

In the future, automation pyramids will be increasingly replaced by a fully networked automation cloud

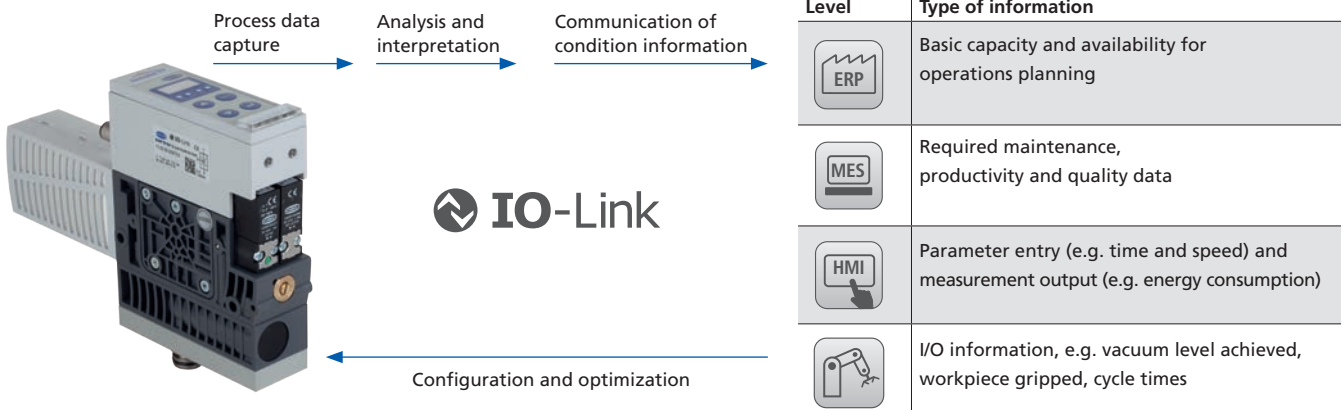

Example of intelligent process communication for the compact ejector SXPI/SXMPi

### ENERGY AND PROCESS DATA – THE BASIS OF INDUSTRY 4.0

Intelligent functions require that all of the relevant process data be available in real time. Schmalz therefore offers smart field devices. They are equipped with comprehensive energy and process control functions, and they gather and interpret data and make it available. This is Schmalz's way of helping its customers on the path toward intelligent factories.

### BENEFITS OF INTELLIGENT VACUUM EJECTORS

The intelligence integrated in Schmalz's compact ejectors ensures both efficient product operation and efficient

control of the overall process. All parameters that are relevant to energy consumption and performance throughout the vacuum system are recorded, monitored, aggregated and analyzed via IO-Link. Compatible systems and services connected via IO-Link, such as intracLOUDs or cloud services, are used to make the information visible in the different integration stages and output channels.

This enables a higher degree of transparency and productivity in automated processes. The energy monitoring function guarantees optimal energy consumption throughout the system. The system's condition is monitored using condition monitoring, which greatly increases system availability. Finally, the predictive maintenance module improves the performance of the gripping system.

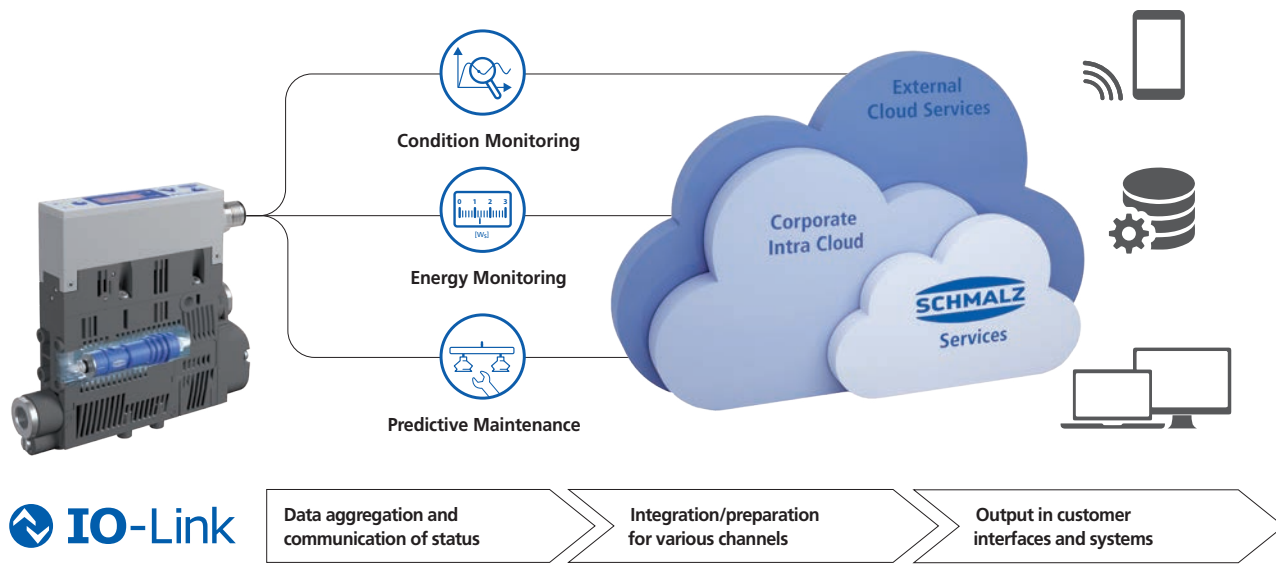

Communication via IO-Link provides a range of opportunities to make the data from Schmalz's intelligent products visible and usable.



- Schmalz – The Company
- Vacuum Suction Cups
- Special Grippers
- Gripping Systems
- Clamping Systems
- Mounting Elements
- Vacuum Generators
- Valve Technology
- Switches and Monitoring
- Filters and Connections
- Services
- Contact
- Glossary
- Index of Products

- Schmalz – The Company
- Vacuum Suction Cups
- Special Grippers
- Gripping Systems
- Clamping Systems
- Mounting Elements
- Vacuum Generators
- Valve Technology
- Switches and Monitoring
- Filters and Connections
- Services
- Contact
- Glossary
- Index of Products



# 6000 Components for Reliable Automation



## VACUUM COMPONENTS THAT DO WHAT THEY PROMISE

Automation with Schmalz vacuum technology is one of the keys to creating efficient process flows in industries. With vacuum technology, sensitive materials such as food products, display glass, electronic components and even large-format sheet metal for car bodies can be gently gripped and handled dynamically.

### Schmalz components for vacuum automation:

- Area grippers
- Clamping systems
- Filters and connectors
- Mounting elements
- Special grippers
- Switches and system monitoring
- Vacuum suction cups
- Vacuum generators
- Valve technology



Our comprehensive range of vacuum technology lets you design custom-tailored vacuum systems

# Vacuum Automation Business Unit

Efficient Automation with Schmalz Vacuum Technology



Flexible system design to meet virtually any customer requirements

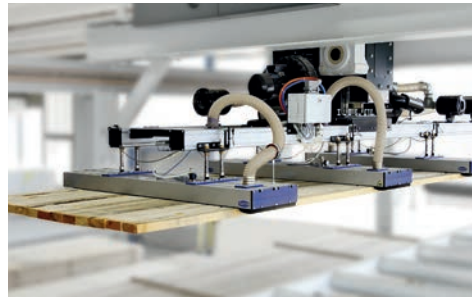

## SCHMALZ GRIPPING SYSTEMS FOR MORE EFFICIENT PROCESS FLOWS

Our gripping systems are used in robots and other automated systems. They handle a wide range of palletizing and logistics applications. In the planning and design phase, Schmalz customers benefit from our many years of experience and our extensive know-how as a system provider.

### Schmalz vacuum gripping systems:

- Layer gripping systems
- Suction spiders

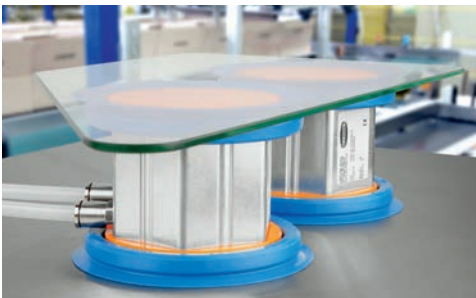

## SCHMALZ CLAMPING SOLUTIONS FOR RELIABLE MACHINING

Schmalz vacuum clamping solutions secure workpieces in CNC machining or assembly processes. They allow you to machine display glass, metal or furniture parts with precision and reliability. Even three-dimensional parts can be clamped flexibly and without additional set-up work.

### Schmalz vacuum clamping solutions:

- For reliable machining of glass, metal, wood and plastic, manually or in CNC machining centers
- 3D clamping solutions, for example for composite textile workpieces

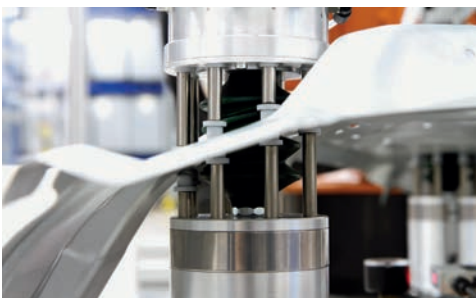

Securely clamp both flat workpieces and three-dimensional free-form surfaces.



- ▶ Vacuum suction cups SAX on a spider with central vacuum generators SXMPi, handling car body parts
- ▼ Gripper with ejector modules SEP handling ampoules



## At Home in Many Industries Worldwide

As an international company with an extensive portfolio of products and services, we offer solutions to customers from a variety of industries. We inspire our customers by showing how vacuum technology can be used to design more efficient production processes. To meet the specific demands of various industries, we offer vacuum components and system solutions for a range of different automation, handling and logistics applications.



COMPOSITE



ELECTRONICS



GLASS



LOGISTICS



METAL



PACKAGING



PLASTICS



SOLAR



WOOD

In the catalog, the industry-specific suitability of each product is indicated using symbols.



## Clean and Flexible Handling

Vacuum automation in electronics production processes offers high efficiency and speed with anti-static handling of assembled printed circuit boards, anodes, cathodes and silicon wafers. Schmalz offers a suction cup range in a wide variety of materials and diameters for every processing step. Vacuum generators with integrated system monitoring ensure consistently high reliability in processes, while extremely compact vacuum components can handle sensitive surfaces with high dynamics and speeds.

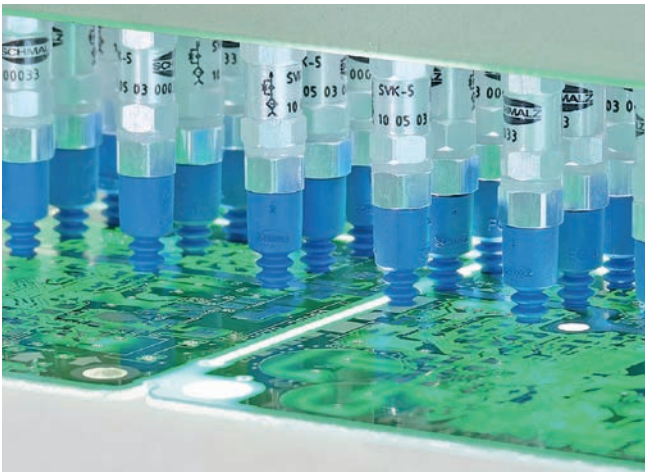

Vacuum suction cups FSG handling blank printed circuit boards



Flow grippers SCG handling assembled printed circuit boards



Schmalz area grippers for the dynamic handling of electrodes



Vacuum suction cups made from anti-static material with spring plungers FSTIm handling assembled printed circuit boards



## Handling of Permeable and Hardened Composite Materials

Carbon-fiber-reinforced plastics are primarily used in the automotive, airline and wind energy industries, but are also used in sporting goods, construction and other sectors. Manufacturing of composite textile workpieces places high demands on the vacuum technology. The alignment of the fibers affects the stiffness of the workpieces. Gentle handling is essential to ensuring that the orientation of the fibers is not disrupted.



Needle gripper SNGi-AE handling composite textiles



Vacuum block BHF for positioning and fixing a hardened composite textile workpiece during edge machining

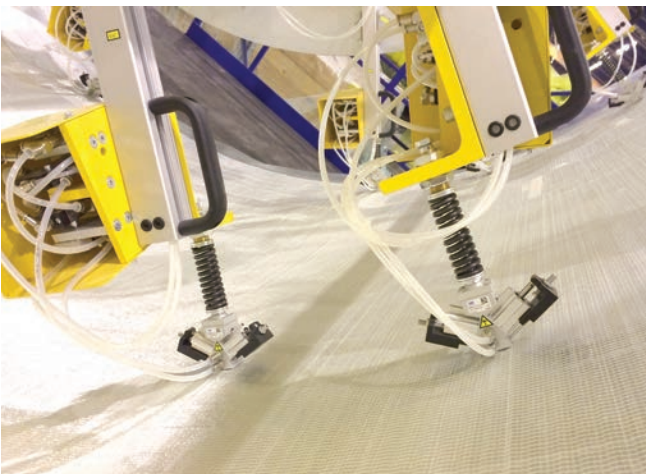

Needle gripper SNG-V handling rotor blade roving in the wind power industry

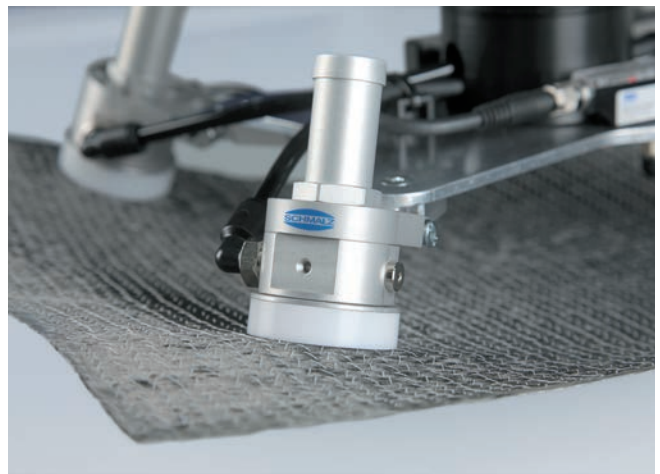

Flow grippers SCG handling composite textiles





## Mark-Free and Secure Handling

Glass workpieces are very sensitive. In many cases, only vacuum technology can handle glass without damage and leaving few marks. The amount of glass used in architecture and the automotive sector is increasing the fastest, but the use of glass in displays is also rising very much. Schmalz offers the perfect glass suction cups for any requirement. We focus on float glass, building glass, automotive glass, solar glass, display glass and container glass segments.



Vacuum suction cups SAB on a spider with central vacuum generator SXMPi handling car side windows



Vacuum suction cups FGA with a compact terminal SCTMi handling glass displays

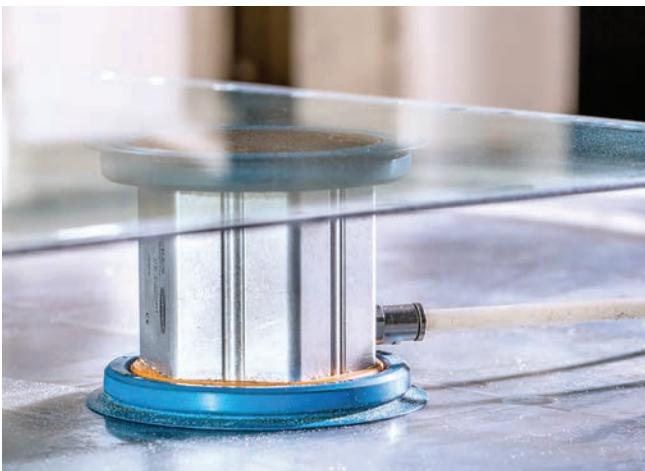

Vacuum block VCBL-GL clamping glass sheets during edge machining



Layer gripping system with a foam suction area and mechanical gripping arms handling hollow jars

Schmalz – The Company

Vacuum Suction Cups

Special Grippers

Gripping Systems

Clamping Systems

Mounting Elements

Vacuum Generators

Valve Technology

Switches and Monitoring

Filters and Connections

Services

Contact

Glossary

Index of Products



## For Various Surfaces and Rough Conditions

Processing this natural raw material involves a wide variety of workpieces – from uneven wood and boards to furniture assemblies and furniture bodies. In workshops and production plants, wooden workpieces are often handled manually using vacuum lifters, or automatically using special gripping systems. For surface machining, wooden boards are secured in CNC machining centers using vacuum clamping technology. Schmalz offers the right vacuum technology for any area of application.



Suction spider SSP with area grippers SBX de-stacking wood in layers



Vacuum block VCBL-K1 fixing a solid wooden board during CNC machining



Vacuum suction cups SPC on a robotic spider loading a machine with coated wooden boards for furniture

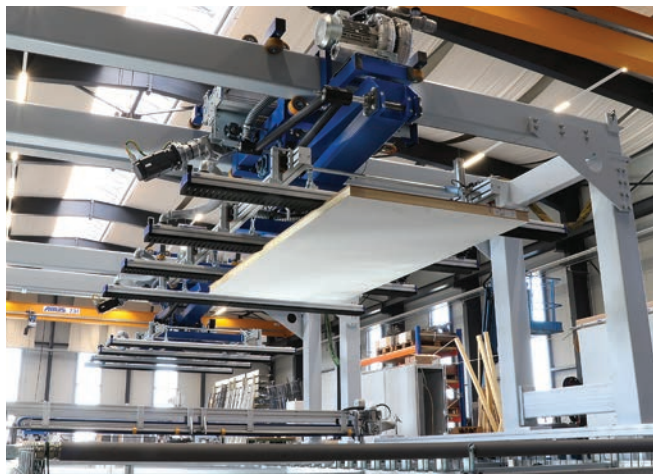

Area gripper FMP on a fully automated loading gantry performing sequential feeding of door panels into a CNC wood working machine



## Removal of Hot Plastics Leaving Few Marks

Schmalz offers a wide variety of vacuum solutions for handling plastics. Specially developed high-temperature-resistant materials allow handling leaving few marks even when workpieces are still hot. Extremely compact vacuum generators provide maximum dynamics and process reliability. Schmalz uses special suction cup materials to allow workpieces to be coated completely, even after handling. Whether it's handling packaging material, insulation or plastics in the automotive industry – with our large portfolio of suction cups for a wide range of applications, we always find the perfect solution for our customers.

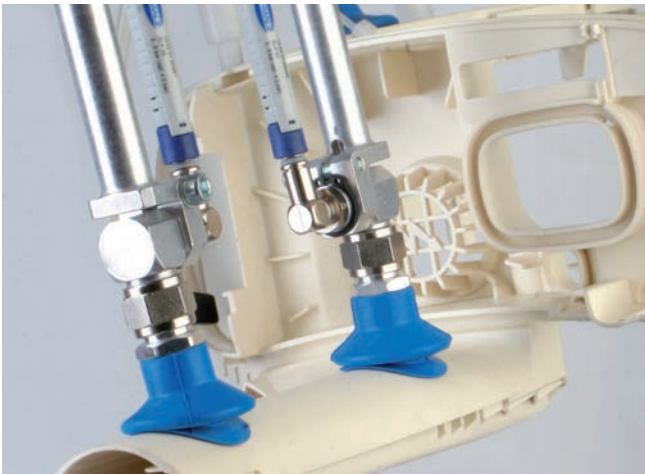

Vacuum suction cups FGA made from a material that leaves few mark handling untreated injection molded parts

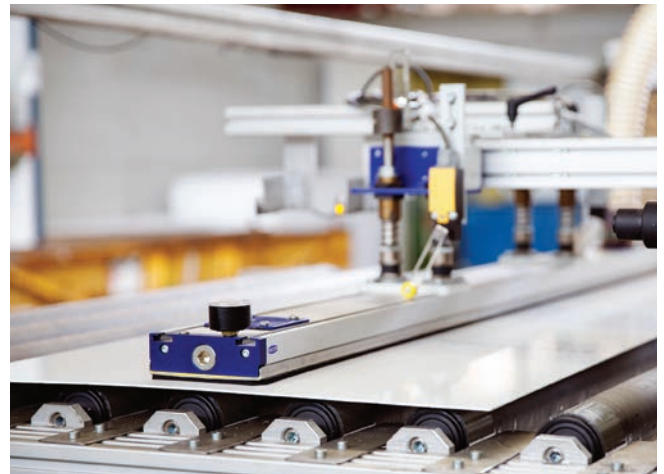

Area gripper FMP de-stacking plastic sheets in layers

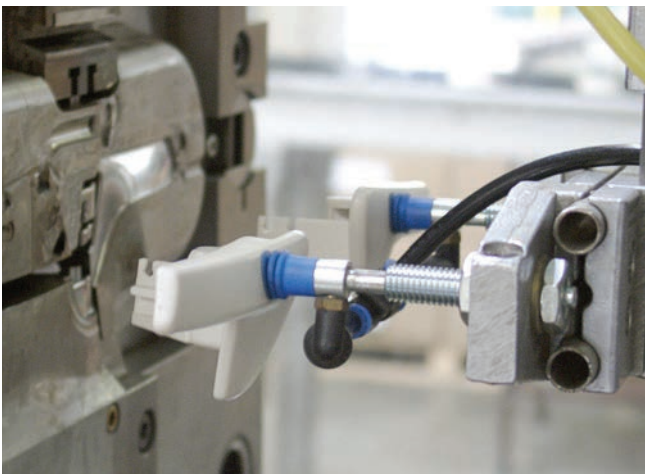

Vacuum suction cups FSG handling hot plastic parts

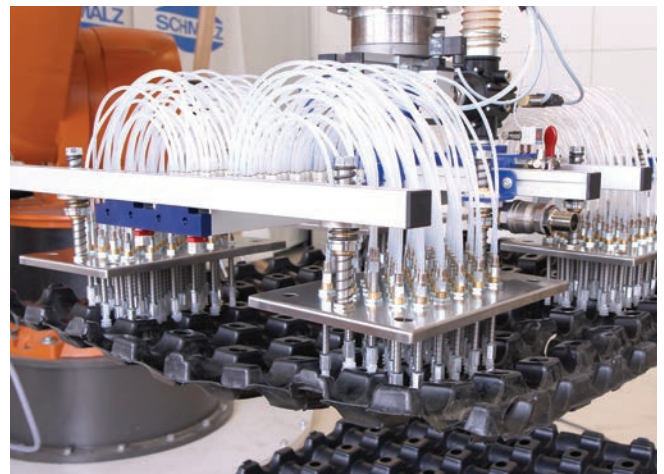

Suction spider de-stacking plastic layer separators



## Flexible Handling Solutions for Intralogistics and Distribution Logistics

Schmalz develops vacuum components, gripping systems and handling systems for a wide variety of applications in the logistics industry. These systems enable customers to boost their productivity, and enhance their workplace safety and ergonomics. Applications for Schmalz's solutions include distribution centers, autonomous warehouses, postal and airport logistics.



Electric vacuum generator ECBPi with custom vacuum end effector VEE on an autonomous robot handling cardboard boxes



Vacuum suction cups FGA made from extremely wear-resistant material handling medium-sized cardboard boxes in shipping logistics



Layer gripping system SPZ order picking cardboard boxes on a forklift



Layer gripping system SPZ with a suction area and global vacuum chamber palletizing beverage trays in layers



## Fast Cycle Times and High Depth of Automation

Vacuum components from Schmalz are used wherever automated handling of parts is needed. This includes, in particular, applications in press shops, body shops and final assembly. Machine tools are automatically or manually loaded and unloaded using vacuum technology. This makes handling and material flow tasks in production processes efficient and safe. Clamping systems hold the workpiece in the machining centers to allow precise machining on all sides.

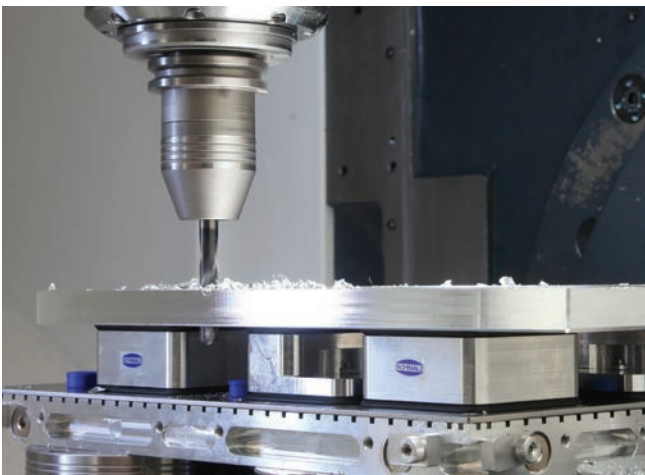

Vacuum clamping system Matrix-Plate with Innospann Steel-Plate and vacuum block involved in five-axis processing of a metal plate



High-temperature suction cups SAB-HT2 handling sheet metal for car bodies

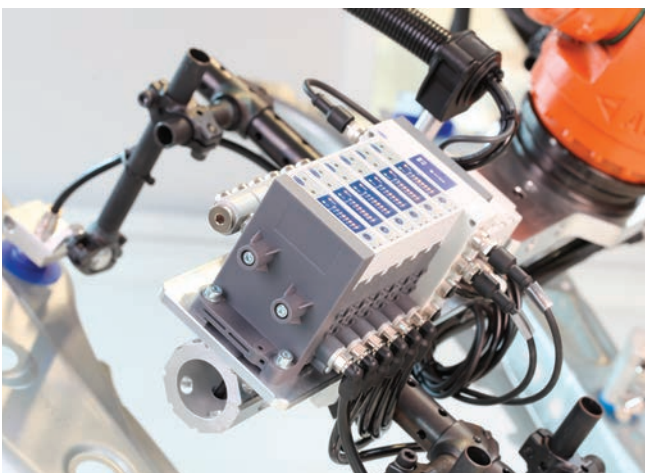

Compact terminal SCTMi handling car body parts



Suction Cup Balance SSCB clamping and handling a curved sheet for a car body

## Extremely Fast, Accurate and Gentle Handling

Products from Schmalz are used throughout the entire process chain; from manufacturing wafers and cells to handling modules and even in thin-film processes. These extremely sensitive workpieces must be gripped gently, while avoiding any marks or contamination. At the same time, the industry has very high standards for speed and dynamics. Cycle times for cell manufacturing processes are generally less than one second. The requirements for vacuum technology are accordingly high.



Wafer gripper SWGm handling solar wafers in a solar panel manufacturing process

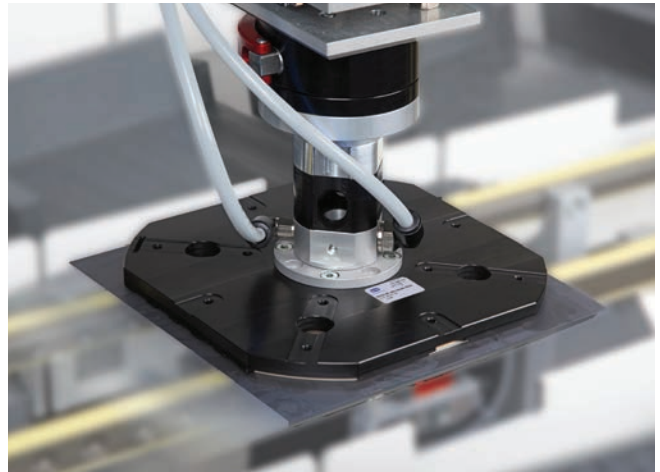

Wafer grippers SWGm handling solar wafers in a solar panel manufacturing process

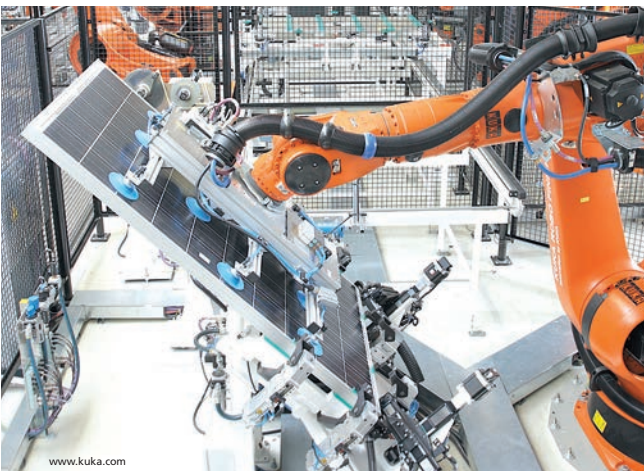

Suction spider handling solar panels in the panel assembly process



Tube lifter JumboErgo handling solar panels



## Handling Products with Different Properties

Packaged items such as food, beverages and other consumer goods require a wide variety of packaging. The packaging has to protect the goods from damage while also presenting them in an appealing manner. The greatest impact is in the food and pharmaceutical industries. Solid, liquid or powdery goods require individual packaging materials such as bottles, tubes, buckets, cardboard boxes and blister packs. Vacuum technology from Schmalz is used in all areas of the packaging industry: suction cups for inserting pralines into trays, compact end effectors for placing the filled bags in a cardboard box and vacuum systems for manual or automated palletizing.



Vacuum suction cups SPB4f made from FDA-compliant silicone with vacuum end effectors VEE handling muffins

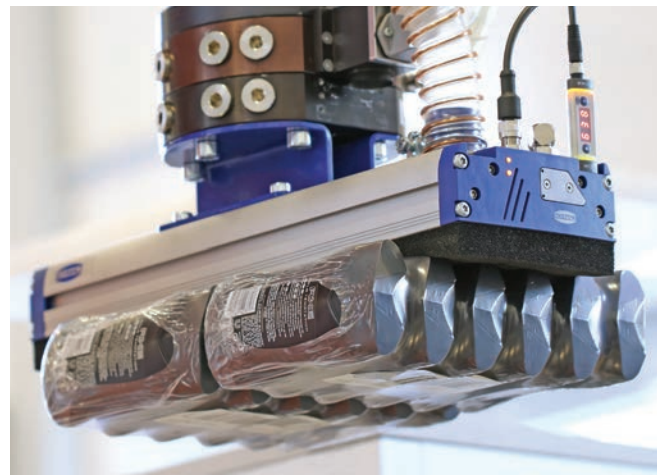

Vacuum gripping system FMP with sealing foam handling shampoo packaging



Gripper with vacuum suction cups made from FDA-compliant silicone and with integrated vacuum generation handling ampoules



Vacuum end effector VEE with suction cups SPB4f handling film-wrapped tissue packages

- Index of Products
- Glossary
- Contact
- Services
- Filters and Connections
- Switches and Monitoring
- Valve Technology
- Vacuum Generators
- Mounting Elements
- Clamping Systems
- Gripping Systems
- Special Grippers
- Vacuum Suction Cups
- Schmalz – The Company

# Vacuum Suction Cups





# Overview of Section

At a Glance

Selection Aid		Page	
	<b>Selection by Field of Application</b>	33	Gripping Systems
	<b>Selection by Material of the Suction Cup</b>	34	Clamping Systems
<b>Flat Suction Cups (Round)</b>			Mounting Elements
	<b>Flat Suction Cups PFYN</b> <ul style="list-style-type: none"> <li>• Diameter: 1 to 200 mm</li> <li>• Material: FPM, HT1, NBR, PU, SI</li> <li>• Antistatic and non-marking variants</li> </ul>	<p>UNIVERSAL</p> <p>Round universal suction cup available in various materials; especially for workpieces with even, smooth surfaces.</p>	36 Vacuum Generators
	<b>Flat Suction Cups PFYN VU1</b> <ul style="list-style-type: none"> <li>• Diameter: 15 to 95 mm</li> <li>• Material: VU1</li> <li>• Connection nipple plugged into elastomer part</li> </ul>	<p>WOOD    PACKAGING    METAL</p> <p>Extremely wear-resistant Vulkollan suction cup for high loads and a long service life in multi-shift operation.</p>	44 Valve Technology
	<b>Suction Plates SPU</b> <ul style="list-style-type: none"> <li>• Diameter: 100 to 400 mm</li> <li>• Material: NBR, SI</li> <li>• Support plate made of aluminum</li> </ul>	<p>UNIVERSAL</p> <p>Round suction cup for smooth and slightly rough workpieces; optionally with peeling insert for separation of sheets.</p>	48 Switches and Monitoring
	<b>Suction Plates SPK</b> <ul style="list-style-type: none"> <li>• Diameter: 55 to 250 mm</li> <li>• Material sealing lip: EPDM</li> <li>• Support plate made of aluminum</li> </ul>	<p>METAL    WOOD    GLASS</p> <p>Round suction cup with adaptable sealing edge for rough and textured workpieces.</p>	53 Filters and Connections
			Services
			Contact
			Glossary
			Index of Products

Schmalz – The Company  
Vacuum Suction Cups  
Special Grippers  
Gripping Systems  
Clamping Systems  
Mounting Elements  
Vacuum Generators  
Valve Technology  
Switches and Monitoring  
Filters and Connections  
Services  
Contact  
Glossary  
Index of Products

# Overview of Section

At a Glance

## Flat Suction Cups (Oval)

Page



### Flat Suction Cups SGON

- Dimensions: 4 x 2 to 90 x 30 mm
- Material: HT1, NBR, SI
- Cups of the size 24 x 8 and larger are additionally secured



Oval flat suction cup with maximum suction force particularly on narrow, elongated workpieces such as sections and pipes.

56



### Suction Plates SPLO

- Dimensions: 60 x 20 to 370 x 80 mm
- Material: NBR
- Support plate vulcanized to elastomer part



Oval flat suction cup with aluminum support plate for narrow, elongated workpieces such as sections and pipes.

62

## Bellows Suction Cups (Round)



### Bellows Suction Cups FSGA (1.5 Folds)

- Diameter: 4 to 78 mm
- Material: HT1, NBR, NK, SI, SI-HD, SI-MD
- Con. nipple plugged into elast. part



Round universal suction cup with 1.5 folds, available in various materials for a wide range of requirements.

66



### Bellows Suction Cups FSGA VU1 (1.5 Folds)

- Diameter: 30 to 110 mm
- Material: VU1
- Connection nipple plugged into elastomer part



Bellows suction cup made of extremely wear-resistant Vulkollan with 1.5 folds for high loads and long service life in multi-shift operation.

72



### Bellows Suction Cups FSGA (1.5 Folds) from Ø110 mm

- Diameter: 110 and 150 mm
- Material: NBR, SI
- Support plate screwed to elastomer part



Round suction cup with 1.5 folds and large diameter for large, heavy, but sensitive workpieces; with attached connection plate.

77



### Bellows Suction Cups FSGPL (1.5 Folds)

- Diameter: 100 to 250 mm
- Material: HT1, NBR
- Support plate vulcanized to elastomer part



Round suction cup with 1.5 folds, large diameter, very soft sealing lip and supports at the bottom.

80



### Bellows Suction Cups FSG (2.5 Folds)

- Diameter: 3 to 88 mm
- Material: HT1, NBR, NBR-AS, NK, SI, SI-AS, SI-HD
- Con. nipple plugged into elast. part



Round universal suction cup with 2.5 folds, available in various materials for a wide range of requirements.

83

# Overview of Section

At a Glance

			Page	Schmalz – The Company
	<p><b>Bellows Suction Cups FSG VU1 (2.5 Folds)</b></p> <ul style="list-style-type: none"> <li>• Diameter: 30 to 85 mm</li> <li>• Material: VU1</li> <li>• Connection nipple plugged into elastomer part</li> </ul>	METAL WOOD PACKAGING	90	Vacuum Suction Cups
<b>Bellows Suction Cups (Oval)</b>				
	<p><b>Bellows Suction Cups FSGAO (1.5 Folds)</b></p> <ul style="list-style-type: none"> <li>• Dimensions: 95 x 40, 140 x 65 mm</li> <li>• Material: VU1</li> <li>• Connection plate screwed to elastomer part</li> </ul>	METAL WOOD PACKAGING	94	Special Grippers
<b>Suction Cups for Handling Sheet Metal</b>				
	<p><b>Bell-Shaped Suction Cups SAX</b></p> <ul style="list-style-type: none"> <li>• Diameter: 30 to 115 mm</li> <li>• Material: ED</li> <li>• Vulcanized connection nipple</li> </ul>	METAL	97	Gripping Systems
	<p><b>Bell-Shaped Suction Cups SAOXM (Oval)</b></p> <ul style="list-style-type: none"> <li>• Dimensions: 60 x 20 to 100 x 40 mm</li> <li>• Material: ED</li> <li>• Connection element modular (assembled)</li> </ul>	METAL	101	Clamping Systems
	<p><b>Flat Suction Cups SAF</b></p> <ul style="list-style-type: none"> <li>• Diameter: 30 to 125 mm</li> <li>• Material: NBR</li> <li>• Connection nipple vulcanized to elastomer part</li> </ul>	METAL	106	Mounting Elements
	<p><b>Bellows Suction Cups SAB (1.5 Folds)</b></p> <ul style="list-style-type: none"> <li>• Diameter: 22 to 125 mm</li> <li>• Material: NBR</li> <li>• Connection nipple vulcanized to elastomer part</li> </ul>	METAL	110	Vacuum Generators
	<p><b>Flat Suction Cups SAOF (Oval)</b></p> <ul style="list-style-type: none"> <li>• Dimensions: 50 x 16 to 140 x 70 mm</li> <li>• Material: NBR</li> <li>• Connection nipple vulcanized to elastomer part</li> </ul>	METAL	114	Valve Technology
				Switches and Monitoring
				Filters and Connections
				Services
				Contact
				Glossary
				Index of Products

# Overview of Section

## At a Glance

Schmalz – The Company

Vacuum Suction Cups

Special Grippers

Gripping Systems

Clamping Systems

Mounting Elements

Vacuum Generators

Valve Technology

Switches and Monitoring

Filters and Connections

Services

Contact

Glossary

Index of Products

Page



### Bellows Suction Cups SAOB (Oval, 1.5 Folds)

- Dimensions: 60 x 30 to 140 x 70 mm
- Material: NBR
- Connection nipple vulcanized to elastomer part



Oval suction cup with 1.5 folds for elongated, curved, thin-walled sheet metal; very high horizontal and vertical holding forces and high suction cup stroke.

118



### Bellows Suction Cups SAB2 P (2.5 Folds)

- Diameter: 20 mm
- Material: NBR, HT1
- Push-in function



Round bellows suction cup with 2.5 folds for strongly curved or thin-walled sheet metal parts. Push-in suction cup neck for direct mounting.

122

## Suction Cups for Handling Wood



### Flat Suction Cups SHFN

- Diameter: 50 to 85 mm
- Material: NK
- Con. nipple plugged into elast. part or support plate vulcan. to elast. part



Round suction cup with internal sealing edge for sealing on rough, slightly textured surfaces.

125



### Suction Plates SHF

- Diameter: 125 to 210 mm
- Material: NK
- Supporting plate securely clipped to elastomer part



Round suction cup with large diameter and internal, double sealing edge for sealing on rough surfaces.

131

## Suction Cups for Packaging



### Flat Suction Cups SPF

- Diameter: 10 mm to 60 mm
- Material: ED
- Connection element modular



Round flat suction cup with support ribs, flexible sealing lip for handling rigid packaging.

134



### Bellows Suction Cups SPB1 (1.5 Folds)

- Diameter: 10 to 80 mm
- Material: ED
- Connection element modular



Round bellows suction cup with 1.5 folds, large suction cup stroke for handling semi-rigid packaging.

139



### Bellows Suction Cups SPOB1 (Oval, 1.5 Folds)

- Dimensions: 60 x 20 and 100 x 40 mm
- Material: ED
- Connection element modular



Oval bellows suction cup with 1.5 folds, large suction stroke for handling rigid packaging.

145

# Overview of Section

At a Glance

			Page	Schmalz – The Company
	<p><b>Bellows Suction Cups SPB2 (2.5 Folds)</b></p> <ul style="list-style-type: none"> <li>• Diameter: 20 to 50 mm</li> <li>• Material: ED</li> <li>• Connection nipple modular</li> </ul>	<p>Round bellows suction cup with 2.5 folds and damping effect as well as large suction stroke for use in carton and tray erectors.</p>	149	Vacuum Suction Cups
	<p><b>Bellows Suction Cups SPB2 P (2.5 Folds) Flow Restrictor</b></p> <ul style="list-style-type: none"> <li>• Diameter: 20 and 40 mm</li> <li>• Material: SI (suitable for food and beverage industry)</li> <li>• Push-in function</li> </ul>	<p>Round bellows suction cup with 2.5 folds, a soft fold geometry and flexible sealing lip for handling non-rigid packaging.</p>	153	Special Grippers Gripping Systems
	<p><b>Bellows Suction Cups SPB4 (4.5 Folds)</b></p> <ul style="list-style-type: none"> <li>• Diameter: 20 to 50 mm</li> <li>• Material: SI (suitable for applications in the food industry)</li> </ul>	<p>Round bellows suction cup with 4.5 folds, soft sealing lip for handling unstable packaging.</p>	156	Clamping Systems Mounting Elements
	<p><b>Bellows Suction Cups SPOB1f (Oval, 1.5 Folds)</b></p> <ul style="list-style-type: none"> <li>• Dimensions: 35 x 15 to 80 x 35 mm</li> <li>• Material: SI (suitable for applications in the food industry)</li> </ul>	<p>Oval bellows suction cup with 1.5 folds for dynamically handling bags and film packaging products in flow-wrap packaging processes.</p>	161	Vacuum Generators
	<p><b>Bellows Suction Cups SPB2f (2.5 Folds)</b></p> <ul style="list-style-type: none"> <li>• Diameter: 30 to 50 mm</li> <li>• Material: SI (use in the food and beverage industry)</li> </ul>	<p>Round bellows suction cup with 2.5 folds for dynamical handling of pouches with extreme wrinkling packaging filled with liquid.</p>	165	Valve Technology Switches and Monitoring
	<p><b>Bellows Suction Cups SPB4f (4.5 Folds)</b></p> <ul style="list-style-type: none"> <li>• Diameter: 30 to 50 mm</li> <li>• Material: SI</li> <li>• Modular connection nipple or push-in function</li> </ul>	<p>Round bellows suction cup with 4.5 folds for handling of bags with extreme wrinkling or pouches filled with liquid.</p>	169	Filters and Connections Services
	<p><b>Bellows Suction Cups FGA PVC (1.5 Folds)</b></p> <ul style="list-style-type: none"> <li>• Diameter: 13 to 22 mm</li> <li>• Material: PVC (suitable for applications in the food industry)</li> </ul>	<p>Round bellows suction cup with 1.5 folds for non-rigid and unstable outer packaging.</p>	174	Contact
	<p><b>Bellows Suction Cups FG PVC (2.5 Folds)</b></p> <ul style="list-style-type: none"> <li>• Diameter: 18 to 50 mm</li> <li>• Material: PVC (suitable for applications in the food industry)</li> </ul>	<p>Round bellows suction cup with 2.5 folds with high suction cup stroke and damping effect for non-rigid and unstable outer packaging.</p>	177	Glossary Index of Products

# Overview of Section

## At a Glance

Schmalz – The Company

Vacuum Suction Cups

Special Grippers

Gripping Systems

Clamping Systems

Mounting Elements

Vacuum Generators

Valve Technology

Switches and Monitoring

Filters and Connections

Services

Contact

Glossary

Index of Products

Page



### Chocolate Suction Cups SPG

- Diameter: 33 mm
- Material: SI, SI-HD (suitable for applications in the food industry)



Bell-shaped chocolate suction cup for handling round, oval or even square chocolate candies in conjunction with picker robots; FDA compliant silicone.

180

## Suction Cups for Plastic Films and Paper



### Flat Suction Cups SGPN

- Diameter: 15 to 40 mm
- Material: FPM, HT1, NK, SI
- Connection nipple plugged into elastomer part



Round suction cup with flat sealing lip for handling of films, wafers without sucking the workpiece in.

183

## Suction Cups for Handling Glass



### Suction Plates SGF

- Diameter: 125 to 400 mm
- Material: EPDM, HT1



Round suction plate for handling of flat, smooth workpieces, such as glass and plastic sheets.

188



### Bellows Suction Cups SAB HT1 (1.5 Folds)

- Diameter: 22 to 125 mm
- Material: HT1
- Connection nipple vulcanized to elastomer part



Round bellows suction cup with 1.5 folds made of mark-free material for handling glass. High holding forces and big stroke.

193



### Bellows Suction Cups SAOB HT1 (Oval, 1.5 Folds)

- Dimensions: 60 x 30 to 140 x 70 mm
- Material: HT1
- Connection nipple vulcanized to elastomer part



Oval bellows suction cup with 1.5 folds made of mark-free material for handling elongated glass. High holding forces and big stroke.

197

## Suction Cups for High-Temperature Applications



### Flat Suction Cups SAF HT2

- Diameter: 30 to 60 mm
- Material: HT2
- Connection nipple vulcanized to elastomer part



Round flat suction cup with low internal volume and very high holding forces for use in high temperature areas.

200



### Bellows Suction Cups SAB HT2 (1.5 Folds)

- Diameter: 22 to 80 mm
- Material: HT2
- Connection nipple vulcanized to elastomer part



Round suction cup with 1.5 folds for extremely curved and thin-walled sheet metal in high temperature areas; very high holding forces and high suction cup stroke.

203

# Overview of Section

At a Glance

			Page	Schmalz – The Company
	<p><b>Flat Suction Cups SAOF HT2 (Oval)</b></p> <ul style="list-style-type: none"> <li>• Dimensions: 60 x 23 to 100 x 50 mm</li> <li>• Material: HT2</li> <li>• Connection nipple vulcanized to elastomer part</li> </ul>	<p>METAL</p> <p>Oval suction cup with low inner volume for elongated sheet metal in high temperature areas; very high holding forces.</p>	206	Vacuum Suction Cups
	<p><b>Bellows Suction Cups SAOB HT2 (Oval, 1.5 Folds)</b></p> <ul style="list-style-type: none"> <li>• Dimensions: 60 x 30 and 80 x 40 mm</li> <li>• Material: HT2</li> <li>• Connection nipple vulcanized to elastomer part</li> </ul>	<p>METAL</p> <p>Oval suction cup with 1.5 folds for elongated, curved sheet metal in high temperature areas; very high holding forces and high suction cup stroke.</p>	209	Special Grippers
	<p><b>Suction Plates for High-Temperature SPL-HT FPM-F</b></p> <ul style="list-style-type: none"> <li>• Diameter: 90 to 190 mm</li> <li>• Material: FPM, coated with felt</li> <li>• Withstands temperatures up to 400° C</li> </ul>	<p>METAL GLASS</p> <p>Suction cup with felt coating for temperature resistance and no marks on the workpiece.</p>	212	Gripping Systems
	<p><b>Suction Plates for High-Temperature SPL-HT</b></p> <ul style="list-style-type: none"> <li>• Diameter: 35 to 140 mm</li> <li>• Material: Special woven silicate</li> <li>• Withstands temperatures up to 600° C</li> </ul>	<p>GLASS METAL</p> <p>Suction cup with replaceable seal and stainless steel basic body for high temperature resistance.</p>	215	Clamping Systems
<b>Suction Cups for Handling Composites</b>				Mounting Elements
	<p><b>Suction Plates SPL POM-NBR</b></p> <ul style="list-style-type: none"> <li>• Diameter: 40 to 115 mm</li> <li>• Material sealing ring: NBR</li> <li>• Support plate made of aluminum</li> </ul>	<p>COMPOSITE</p> <p>Round suction plate with adaptable sealing ring for handling flexible materials such as prepreg or semi-finished products of fiber composite material.</p>	217	Vacuum Generators
<b>Sealing Profiles</b>				Valve Technology
	<p><b>Sealing Cords DI-SCHN</b></p> <ul style="list-style-type: none"> <li>• Diameter: 6 to 12 mm</li> <li>• Cross-sections: 8 x 1 to 25 x 20 mm</li> </ul>	<p>UNIVERSAL</p> <p>Sealing profiles with various dimensions for producing individual suction plates.</p>	219	Switches and Monitoring
	<p><b>Sealing Profiles DI-PROF</b></p> <ul style="list-style-type: none"> <li>• Dimensions: 5.5 x 8 to 30 x 25 mm</li> <li>• For constructing special suction plates</li> </ul>	<p>UNIVERSAL</p> <p>Sealing profiles made from two components for individual production of suction plates for extremely rough and textured surfaces.</p>	221	Filters and Connections
				Services
				Contact
				Glossary
				Index of Products

# Overview of Section

At a Glance

Schmalz – The Company

Vacuum Suction Cups

Special Grippers

Gripping Systems

Clamping Systems

Mounting Elements

Vacuum Generators

Valve Technology

Switches and Monitoring

Filters and Connections

Services

Contact

Glossary

Index of Products

## Accessories Vacuum Suction Cups

Page

	<p><b>Filter Discs FD</b></p> <ul style="list-style-type: none"> <li>• Diameter: 16 to 55 mm</li> <li>• For suction cup type: FGA, FG</li> <li>• Material: PE</li> </ul>	<p>WOOD    PACKAGING    COMPOSITE</p>	<p>The filter plate stops the workpiece from being sucked in to the suction cup.</p>	<p>225</p>
	<p><b>Suction Cup Inserts SPI PEEK</b></p> <ul style="list-style-type: none"> <li>• Diameter: 6 to 32 mm</li> <li>• For suction cup type: FGA, FG</li> <li>• Material: PEEK</li> </ul>	<p>GLASS</p>	<p>Cup inserts SPI made of PEEK for bellows suction cups FGA and FG for gentle and mark free gripping and depositing of smooth workpieces.</p>	<p>228</p>
	<p><b>Suction Cup Covers SU</b></p> <ul style="list-style-type: none"> <li>• Diameter: 25 to 360 mm</li> <li>• For suction cups and suction plates</li> </ul>	<p>GLASS    SOLAR</p>	<p>Suction cup cover for handling delicate, flat and smooth workpieces (non-marking).</p>	<p>230</p>
	<p><b>Protection Covers PC</b></p> <ul style="list-style-type: none"> <li>• Diameter: 125 to 400 mm</li> <li>• Protection of suction cups and suction plates</li> </ul>	<p>UNIVERSAL</p>	<p>Protection cover PC to protect the suction plates from environmental influences and aging during storage or when suction plates are not in use.</p>	<p>233</p>
	<p><b>Sealing Rings DR-MOS SI</b></p> <ul style="list-style-type: none"> <li>• Diameter: 20/10 x 2 to 88/64 x 5 mm</li> <li>• For suction cup type: FGA, FG</li> <li>• Material: SI</li> </ul>	<p>UNIVERSAL</p>	<p>Sealing ring made from special foam for optimum sealing on structured surfaces.</p>	<p>235</p>



# Selection by Field of Application



## Universal Suction Cup

Shape		Family	Suction area	Page	
Round		PFYN	Ø 1 mm – 200 mm	36	
		PFYN VU1	Ø 15 mm – 95 mm	44	
		SPU	Ø 100 mm – 400 mm	48	
		SPK	Ø 55 mm – 250 mm	53	
		FSGA	Ø 4 mm – 78 mm	66	
		FSGA VU1	Ø 30 mm – 110 mm	72	
		FSGA 110	Ø 110 mm – 150 mm	77	
		FSGPL	Ø 100 mm – 250 mm	80	
		FSG	Ø 3 mm – 88 mm	83	
		FSG VU1	Ø 30 mm – 85 mm	90	
	Oval		SGON	4 x 2 – 90 x 30	56
			SPLO	60 x 20 – 370 x 80	62
		FSGAO	95 x 40 – 140 x 65	94	



## Suction Cups for Packaging

Shape		Family	Suction area	Page
Round		SPF	Ø 10 mm – 60 mm	134
		SPG	Ø 33 mm	180
		SPB1	Ø 10 mm – 80 mm	139
		FGA PVC	Ø 13 mm – 22 mm	174
		SPB2	Ø 20 mm – 50 mm	149
		SPB2 P	Ø 20 mm – 40 mm	153
		SPB2f	Ø 30 mm – 50 mm	165
		FG PVC	Ø 18 mm – 50 mm	177
		SPB4	Ø 20 mm – 50 mm	156
		SPB4f	Ø 30 mm – 50 mm	169
Oval		SPOB1	60 x 20 – 100 x 40	145
		SPOB1f	35 x 15 – 80 x 35	161



## Suction Cups for Handling Sheet Metal

Shape		Family	Suction area	Page
Round		SAF	Ø 30 mm – 125 mm	106
		SAX	Ø 30 mm – 115 mm	97
		SAB	Ø 22 mm – 125 mm	110
		SAB2 P	Ø 20 mm	122
Oval		SAOF	50 x 16 – 140 x 70	114
		SAOXM	60 x 20 – 100 x 40	101
		SAOB	60 x 30 – 140 x 70	118



## Suction Cups for High-Temperature Applications

Shape		Family	Suction area	Page
Round		SAF HT2	Ø 30 mm – 60 mm	200
		SPL-HT FPM-F	Ø 90 mm – 190 mm	212
		SPL-HT	Ø 35 mm – 140 mm	215
		SAB HT2	Ø 22 mm – 80 mm	203
Oval		SAOF HT2	60 x 23 – 100 x 50	206
		SAOB HT2	60 x 30 – 80 x 40	209



## Suction Cups for Handling Wood

Shape		Family	Suction area	Page
Round		SHFN	Ø 50 mm – 85 mm	125
		SHF	Ø 125 mm – 210 mm	131



## Suction Cups for Handling Glass

Shape		Family	Suction area	Page
Round		SGF	Ø 125 mm – 400 mm	188
			SAB HT1	Ø 22 mm – 125 mm
Oval		SAOB HT1	60 x 30 – 140 x 70	197



## Suction Cups for Plastic Films and Paper

Shape		Family	Suction area	Page
Round		SGPN	Ø 15 mm – 40 mm	183



## Suction Cups for Handling Composites

Shape		Family	Suction area	Page
Round		SPL-POM NBR	Ø 40 mm – 115 mm	217

Flat suction cups

Bell-shaped suction cups

Bellows suction cups (1.5 / 2.5 / 3.5 / 4.5 folds)



# Selection by Material of the Suction Cup

## Material Overview

Description	Abbreviation	NBR	NBR-AS	SI (SI-HD/SI-MD)	SI-AS	NK	HT1
	Chemical designation / trade name	Nitrile caoutchuc (AS = antistatic)		Silicone caoutchuc (AS = antistatic) (MD = metal detectable) (HD = heavy duty)		Natural rubber	High temperature material
Color / coding	black, gray, blue, light blue	black with blue dot	nature, green, light blue	black with red dot	gray, light brown	blue	
Chemical resistance	General weathering resistance	●●	●●	●●●	●●●	●●	●●●
	Ozone resistance	●	●	●●●●	●●●●	●	●●●●
	Oil resistance	●●●●	●●●●	●●	●●	●	●●●●
	Fuel resistance	●●	●●	●	●	●	●●
	Alcohol resistance, ethanol 96 %	●●●●	●●●	●●●●	●●●	●●●●	●●●●
	Solvents resistance	●●	●●	●●	●●	●	●●
	General resistance to acids	●	●	●●	●●	●●	●
	Bases resistance	●	●	●●	●●	●	●
	Steam resistance	●●	●●	●●	●●	●	●●●
Mechanical characteristics	Abrasion values	●●	●●	● (●)	●	●●	●●●
	Resistance to permanent deformation	●●	●●	●●	●●	●●●	●●
	Tensile strength	●●	●●	●	●	●●	●●
	Specific resistance in [ $\Omega \times \text{cm}$ ]	–	$10^3$ to $10^{6^{1)}$	–	$10^3$ to $10^{6^{1)}$	–	–
	Shore hardness to DIN ISO 7619	40 to $80 \pm 5$	$55 \pm 5$	40 to $70 \pm 5^{2)}$ ( $65 \pm 5$ )	$55 \pm 5$	35 to $55 \pm 5$	$60 \pm 5$
Temperature resistance <sup>3)</sup>	Short-term in °C (< 30 sec.)	-30° to +120°	-30° to +120°	-40° to +220°	-35° to +220°	-35° to +120°	-25° to +170°
	Longer-term in °C	-10° to +70°	-10° to +70°	-30° to +180°	-20° to +180°	-25° to +80°	-10° to +140°
Further characteristics	Target industry	Universal	(Universal), Electronics	Packaging	Electronics	Wood, Packaging	Plastics, Glass
	Food grade according to CFR 21 §177.2600 FDA			✓			
	Leaving few marks						✓
	Absence of PWIS (paint-wetting impairment substances)	NBR-60, NBR-45					✓
	Cleanroom suitability	on request	on request	●●● (●)	on request	on request	●●●

<sup>1)</sup> Depending on size and geometry

<sup>2)</sup> After-bake of silicone 4 h/200° C = ~+5 Shore A

<sup>3)</sup> Approximate value: depends on ambient temperature, application force, recovery time and wall thickness of suction cup

●●●● Excellent      ●●● Very good      ●● Good      ● Poor to satisfactory

Schmalz – The Company  
 Vacuum Suction Cups  
 Special Grippers  
 Gripping Systems  
 Clamping Systems  
 Mounting Elements  
 Vacuum Generators  
 Valve Technology  
 Switches and Monitoring  
 Filters and Connections  
 Services  
 Contact  
 Glossary  
 Index of Products

HT2	ED	PU	VU1	PVC	FPM	EPDM	EPDM-MOS
High temperature material	Elastodur	Polyurethane	Vulkollan® 4)	Polyvinylchloride	Fluorcaoutchuc	Ethylene propylene caoutchuc	Foam rubber made of ethylene propylene caoutchuc
black	green, blue	blue	dark green	blue (translucid)	black with white dot	grey	black
●●●●	●●●	●●●	●●●	●●	●●●●	●●●●	●●●●
●●●	●●●	●●●	●●●	●●●	●●●●	●●●●	●●●●
●●●●	●●●	●●●	●●●	●●●	●●●●	●● <sup>5)</sup>	●● <sup>5)</sup>
●●●	●●	●●	●●	●	●●●●	●	●●
●●	●●●	●●●	●●●	●	●●	●●●●	●●●●
●●●	●	●	●	●	●●	●●	●●
●●●	●	●	●	●●	●●	●●●	●●●
●●	●	●	●	●●	●●	●●●	●●●
●●	●	●	●	●●●	●●	●●●	●●●
●	●●● (●)	●●●●	●●●●	●●●	●	●●	●
●●	●	●●	●●	●	●●	●●	●●
●●	●●● (●)	●●●	●●●●	●●	●●	●●	●
–	–	–	–	–	–	–	–
65 ± 5	60 to 85 ± 5	55 ± 5	72 ± 5	50 ± 5	65 ± 5	55 ± 5	~15 <sup>6)</sup>
-10° to +250°	-40° to +100°	-40° to +130°	-40° to +100°	-30° to +65°	-10° to +250°	-35° to +130°	-35° to +100°
-5° to +200°	-25° to +80°	-30° to +100°	-30° to +80°	-15° to +50°	-5° to +200°	-25° to +100°	-25° to +70°
Glass, Solar, Metal	Packaging, Metal	Packaging	Metal, Packaging, Glass, Wood	Packaging	Glass, Solar, Metal	Glass	Metal, Wood
				✓ <sup>7)</sup>			
	✓				✓		
	ED-85						
●●●	●●● (●)	on request	on request	on request	●●●	on request	on request

Vacuum Suction Cups

Special Grippers

Gripping Systems

Clamping Systems

Mounting Elements

Vacuum Generators

Valve Technology

Switches and Monitoring

Filters and Connections

Services

Contact

Glossary

Index of Products

<sup>4)</sup>Vulkollan® is a registered trademark of Bayer AG

<sup>5)</sup>With slight oil wetting

<sup>6)</sup>Varies, for technical reasons, for foam rubber

<sup>7)</sup>For PVC: CFR 21 §175.300 FDA

# Flat Suction Cups PFYN

Suction area (Ø) from 1 mm to 200 mm



## Suitability for Industry Specific Applications

### Applications

- Round, flat suction cup for handling of flat workpieces with smooth or slightly rough surfaces
- Handling of hot workpieces (HT1, SI, FPM)
- Low marking and antistatic handling of sensitive workpieces (HT1 and AS versions)

### Design

- Robust, wear-resistant suction cup PFYN (3) with single sealing lip, consisting of suction cup PFG (2) and connection nipple (1)
- Nipple plugged in on cups up to 50 mm in diameter
- Nipple screwed into a metal inlay (vulcanized to the cup) on cups with a diameter of 60 mm or more
- Within each nipple family, the replacement cups and nipples can be combined as desired

### Our Highlights...

- Different materials
- Wide range of diameters
- Optimum shape
- Low internal volume
- Supports on the bottom side

### Your Benefits...

- Suction cups for a wide range of applications (high temperatures, antistatic, low marking, resistance to chemicals)
- Wide range of versions for different sizes and types of workpieces
- High suction forces with small dimensions
- For very short cycle times
- No perman. deformation of thin-walled workpieces

- Schmalz – The Company
- Vacuum Suction Cups
- Special Grippers
- Gripping Systems
- Clamping Systems
- Mounting Elements
- Vacuum Generators
- Valve Technology
- Switches and Monitoring
- Filters and Connections
- Services
- Contact
- Glossary
- Index of Products



Flat Suction Cups PFYN

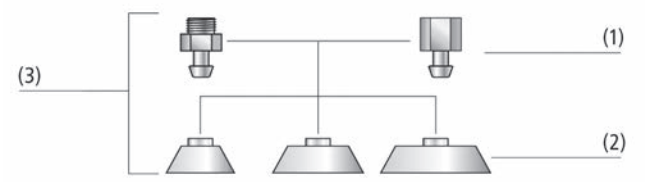

System Design Flat Suction Cups PFYN



Flat suction cups PFYN being used for handling plastic boards

# Flat Suction Cups PFYN

Suction area (Ø) from 1 mm to 200 mm

## Designation Code Flat Suction Cups PFYN



### 1 – Abbreviated designation

Code	Version
PFYN	Flat

### 2 – Suction area

Code	Diameter in mm
1...200	ø 1 to 200

### 3 – Material

Code	Material
FPM-65	Fluorcaoutchuc
HT1-60	High temperature material
NBR-55	Nitrile caoutchuc
NBR-AS-55	Nitrile caoutchuc
PU-55	Polyurethane
SI-55	Silicone
SI-AS-55	Silicone

### 4 – Connection

Code	Connection
M3-AG	M3-AG (AG = male (M))
M5-AG	M5-AG
M5-IG	M5-IG (IG = female (F))
G1/8-AG	G1/8-AG
G1/8-IG	G1/8-IG
G1/4-AG	G1/4-AG
G1/4-IG	G1/4-IG
G1/2-IG	G1/2-IG

Suction cup PFYN (elastomer part + connection nipple) is delivered unassembled (diameters of 120 mm and more are assembled). The delivery consists of:

- Suction cup of type PFG – elastomer part, available in various diameters and materials
- Connection nipple of type SA-NIP – available with various threads

Available spare parts: suction cup PFG, connection nipple SA-NIP

## Ordering Data Flat Suction Cups PFYN

Type	Suction cup material with ShA: *							
		FPM-65	HT1-60	NBR-55	NBR-AS-55	PU-55	SI-55	SI-AS-55
PFYN 1	M3-AG	-	-	10.01.01.00274	10.01.01.10375	-	10.01.01.00280	-
PFYN 1.5	M3-AG	-	-	10.01.01.00275	10.01.01.10376	-	10.01.01.00281	-
PFYN 2	M3-AG	-	10.01.01.13000	10.01.01.00276	10.01.01.10377	-	10.01.01.00282	10.01.01.10391
PFYN 3.5	M3-AG	10.01.01.00295	10.01.01.12982	10.01.01.00277	10.01.01.10378	-	10.01.01.00283	10.01.01.10392
PFYN 5	M5-AG	10.01.01.00179	10.01.01.11130	10.01.01.00137	10.01.01.10379	-	10.01.01.00151	10.01.01.10393
PFYN 5	M5-IG	10.01.01.00123	10.01.01.11144	10.01.01.00081	10.01.01.10345	-	10.01.01.00095	10.01.01.10357
PFYN 6	M5-AG	10.01.01.00180	10.01.01.11131	10.01.01.00138	10.01.01.10380	-	10.01.01.00152	10.01.01.10394
PFYN 6	M5-IG	10.01.01.00124	10.01.01.11145	10.01.01.00082	10.01.01.10346	-	10.01.01.00096	10.01.01.10358
PFYN 8	M5-AG	10.01.01.00181	10.01.01.11132	10.01.01.00139	10.01.01.10381	10.01.01.00167	10.01.01.00153	10.01.01.10395
PFYN 8	M5-IG	10.01.01.00125	10.01.01.11146	10.01.01.00083	10.01.01.10347	10.01.01.00111	10.01.01.00097	10.01.01.10359
PFYN 10	M5-AG	10.01.01.00182	10.01.01.11133	10.01.01.00140	10.01.01.10382	10.01.01.00168	10.01.01.00154	10.01.01.10396
PFYN 10	M5-IG	10.01.01.00126	10.01.01.11147	10.01.01.00084	10.01.01.10348	10.01.01.00112	10.01.01.00098	10.01.01.10360
PFYN 10	G1/8-AG	10.01.01.00297	10.01.01.11134	10.01.01.00279	10.01.01.10383	10.01.01.00291	10.01.01.00285	10.01.01.10397
PFYN 10	G1/8-IG	10.01.01.00273	10.01.01.11148	10.01.01.00255	10.01.01.10349	10.01.01.00267	10.01.01.00261	10.01.01.10361
PFYN 15	G1/8-AG	10.01.01.00183	10.01.01.11135	10.01.01.00141	10.01.01.10384	10.01.01.00169	10.01.01.00155	10.01.01.10398
PFYN 15	G1/8-IG	10.01.01.00127	10.01.01.11149	10.01.01.00085	10.01.01.10350	10.01.01.00113	10.01.01.00099	10.01.01.10362
PFYN 20	G1/8-AG	10.01.01.00184	10.01.01.11136	10.01.01.00142	10.01.01.10385	10.01.01.00170	10.01.01.00156	-
PFYN 20	G1/8-IG	10.01.01.00128	10.01.01.11150	10.01.01.00086	10.01.01.10351	10.01.01.00114	10.01.01.00100	-
PFYN 25	G1/8-AG	10.01.01.00185	10.01.01.11137	10.01.01.00143	10.01.01.10386	10.01.01.00171	10.01.01.00157	-
PFYN 25	G1/8-IG	10.01.01.00129	10.01.01.11151	10.01.01.00087	10.01.01.10352	10.01.01.00115	10.01.01.00101	-
PFYN 30	G1/8-AG	10.01.01.00186	10.01.01.11138	10.01.01.00144	10.01.01.10387	10.01.01.00172	10.01.01.00158	-
PFYN 30	G1/8-IG	10.01.01.00130	10.01.01.11152	10.01.01.00088	10.01.01.10353	10.01.01.00116	10.01.01.00102	-



Schmalz – The Company  
Vacuum Suction Cups  
Special Grippers  
Gripping Systems  
Clamping Systems  
Mounting Elements  
Vacuum Generators  
Valve Technology  
Switches and Monitoring  
Filters and Connections  
Services  
Contact  
Glossary  
Index of Products

# Flat Suction Cups PFYN

Suction area (Ø) from 1 mm to 200 mm

## Ordering Data Flat Suction Cups PFYN

Type			Suction cup material with ShA: *						
			FPM-65	HT1-60	NBR-55	NBR-AS-55	PU-55	SI-55	SI-AS-55
PFYN	35	G1/8-AG	10.01.01.00187	10.01.01.11139	10.01.01.00145	10.01.01.10388	10.01.01.00173	10.01.01.00159	-
PFYN	35	G1/8-IG	10.01.01.00131	10.01.01.11153	10.01.01.00089	10.01.01.10354	10.01.01.00117	10.01.01.00103	-
PFYN	40	G1/8-AG	10.01.01.00188	10.01.01.11140	10.01.01.00146	10.01.01.10389	10.01.01.00174	10.01.01.00160	-
PFYN	40	G1/8-IG	10.01.01.00132	10.01.01.11154	10.01.01.00090	10.01.01.10355	10.01.01.00118	10.01.01.00104	-
PFYN	50	G1/8-AG	10.01.01.00189	10.01.01.11141	10.01.01.00147	10.01.01.10390	10.01.01.00175	10.01.01.00161	-
PFYN	50	G1/8-IG	10.01.01.00133	10.01.01.11155	10.01.01.00091	10.01.01.10356	10.01.01.00119	10.01.01.00105	-
PFYN	60	G1/4-AG	10.01.01.00190	10.01.01.11142	10.01.01.00148	-	10.01.01.00176	10.01.01.00162	-
PFYN	60	G1/4-IG	10.01.01.00134	10.01.01.11156	10.01.01.00092	-	10.01.01.00120	10.01.01.00106	-
PFYN	80	G1/4-AG	10.01.01.00191	10.01.01.11143	10.01.01.00149	-	10.01.01.00177	10.01.01.00163	-
PFYN	80	G1/4-IG	10.01.01.00135	10.01.01.11157	10.01.01.00093	-	10.01.01.00121	10.01.01.00107	-
PFYN	95	G1/4-AG	10.01.01.00192	10.01.01.13774	10.01.01.00150	-	10.01.01.00178	10.01.01.00164	-
PFYN	95	G1/4-IG	10.01.01.00136	10.01.01.13762	10.01.01.00094	-	10.01.01.00122	10.01.01.00108	-
PFYN	120	G1/2-IG	10.01.01.12052	-	10.01.01.00337	-	-	10.01.01.00338	-
PFYN	150	G1/2-IG	-	-	10.01.01.00339	-	-	10.01.01.00340	-
PFYN	200	G1/2-IG	-	-	10.01.01.00341	-	-	10.01.01.00342	-

\*Additional material specifications at beginning of the section "Vacuum Suction Cups"

## Ordering Data Spare Parts Flat Suction Cups PFYN

Type			Suction cup material with ShA: *						
			FPM-65	HT1-60	NBR-55	NBR-AS-55	PU-55	SI-55	SI-AS-55
PFG	1		-	-	10.01.01.00001	10.01.01.10335	-	10.01.01.00021	-
PFG	1.5		-	-	10.01.01.00002	10.01.01.10336	-	10.01.01.00022	-
PFG	2		-	10.01.01.12967	10.01.01.00003	10.01.01.10063	-	10.01.01.00023	10.01.01.10050
PFG	3.5		10.01.01.00064	10.01.01.12981	10.01.01.00004	10.01.01.10042	-	10.01.01.00024	10.01.01.00752
PFG	5		10.01.01.00067	10.01.01.11158	10.01.01.00007	10.01.01.10064	-	10.01.01.00027	10.01.01.10051
PFG	6		10.01.01.00068	10.01.01.11159	10.01.01.00008	10.01.01.10065	-	10.01.01.00028	10.01.01.00626
PFG	8		10.01.01.00069	10.01.01.11160	10.01.01.00009	10.01.01.10043	10.01.01.00049	10.01.01.00029	10.01.01.00647
PFG	10		10.01.01.00070	10.01.01.11161	10.01.01.00010	10.01.01.10066	10.01.01.00050	10.01.01.00030	10.01.01.00701
PFG	15		10.01.01.00071	10.01.01.11162	10.01.01.00011	10.01.01.10067	10.01.01.00051	10.01.01.00031	10.01.01.00627
PFG	20		10.01.01.00072	10.01.01.11163	10.01.01.00012	10.01.01.10337	10.01.01.00052	10.01.01.00032	-
PFG	25		10.01.01.00073	10.01.01.11164	10.01.01.00013	10.01.01.10338	10.01.01.00053	10.01.01.00033	-
PFG	30		10.01.01.00074	10.01.01.11165	10.01.01.00014	10.01.01.10339	10.01.01.00054	10.01.01.00034	-
PFG	35		10.01.01.00075	10.01.01.11166	10.01.01.00015	10.01.01.10340	10.01.01.00055	10.01.01.00035	-
PFG	40		10.01.01.00076	10.01.01.11167	10.01.01.00016	10.01.01.10341	10.01.01.00056	10.01.01.00036	-
PFG	50		10.01.01.00077	10.01.01.11168	10.01.01.00017	10.01.01.10342	10.01.01.00057	10.01.01.00037	-
PFG	60		10.01.01.00078	10.01.01.11169	10.01.01.00018	-	10.01.01.00058	10.01.01.00038	-
PFG	80		10.01.01.00079	10.01.01.11170	10.01.01.00019	-	10.01.01.00059	10.01.01.00039	-
PFG	95		10.01.01.00080	10.01.01.13160	10.01.01.00020	-	10.01.01.00060	10.01.01.00040	-
PFG	120		10.01.01.00389	-	10.01.01.00331	-	-	10.01.01.00332	-
PFG	150		-	10.01.01.13445	10.01.01.00333	-	-	10.01.01.00334	-
PFG	200		-	-	10.01.01.00335	-	-	10.01.01.00336	-

\*Additional material specifications at beginning of the section "Vacuum Suction Cups"

Type	Spare Parts			Part no.	
PFYN	1	M3-AG	Suction cup connection nipple	SA-NIP N001 M3-AG DN40	10.01.01.00315
PFYN	1.5	M3-AG	Suction cup connection nipple	SA-NIP N002 M3-AG DN70	10.01.01.00314
PFYN	2	M3-AG	Suction cup connection nipple	SA-NIP N003 M3-AG DN100	10.01.01.00316
PFYN	3.5	M3-AG	Suction cup connection nipple	SA-NIP N003 M3-AG DN100	10.01.01.00316
PFYN	5	M5-AG	Suction cup connection nipple	SA-NIP N004 M5-AG DN200	10.01.01.03526
PFYN	6	M5-AG	Suction cup connection nipple	SA-NIP N004 M5-AG DN200	10.01.01.03526

# Flat Suction Cups PFYN

Suction area (Ø) from 1 mm to 200 mm



## Ordering Data Spare Parts Flat Suction Cups PFYN

Type	Spare Parts			Part no.
PFYN 8	M5-AG	Suction cup connection nipple	SA-NIP N004 M5-AG DN200	10.01.01.03526
PFYN 10	M5-AG	Suction cup connection nipple	SA-NIP N004 M5-AG DN200	10.01.01.03526
PFYN 10	G1/8-AG	Suction cup connection nipple	SA-NIP N004 G1/8-AG DN200	10.01.01.03528
PFYN 15	G1/8-AG	Suction cup connection nipple	SA-NIP N005 G1/8-AG DN200	10.01.01.03529
PFYN 20	G1/8-AG	Suction cup connection nipple	SA-NIP N006 G1/8-AG DN200	10.01.01.03530
PFYN 25	G1/8-AG	Suction cup connection nipple	SA-NIP N007 G1/8-AG DN240	10.01.01.03531
PFYN 30	G1/8-AG	Suction cup connection nipple	SA-NIP N007 G1/8-AG DN240	10.01.01.03531
PFYN 35	G1/8-AG	Suction cup connection nipple	SA-NIP N007 G1/8-AG DN240	10.01.01.03531
PFYN 40	G1/8-AG	Suction cup connection nipple	SA-NIP N007 G1/8-AG DN240	10.01.01.03531
PFYN 50	G1/8-AG	Suction cup connection nipple	SA-NIP N008 G1/8-AG DN240	10.01.01.03532
PFYN 60	G1/4-AG	Suction cup connection nipple (inst)	SA-NIP N009 G1/4-AG	10.01.01.10097
PFYN 80	G1/4-AG	Suction cup connection nipple (inst)	SA-NIP N009 G1/4-AG	10.01.01.10097
PFYN 95	G1/4-AG	Suction cup connection nipple (inst)	SA-NIP N009 G1/4-AG	10.01.01.10097

Type	Spare Parts			Part no.
PFYN 5	M5-IG	Suction cup connection nipple	SA-NIP N004 M5-IG DN200	10.01.01.03518
PFYN 6	M5-IG	Suction cup connection nipple	SA-NIP N004 M5-IG DN200	10.01.01.03518
PFYN 8	M5-IG	Suction cup connection nipple	SA-NIP N004 M5-IG DN200	10.01.01.03518
PFYN 10	M5-IG	Suction cup connection nipple	SA-NIP N004 M5-IG DN200	10.01.01.03518
PFYN 10	G1/8-IG	Suction cup connection nipple	SA-NIP N004 G1/8-IG DN200	10.01.01.03520
PFYN 15	G1/8-IG	Suction cup connection nipple	SA-NIP N005 G1/8-IG DN200	10.01.01.03521
PFYN 20	G1/8-IG	Suction cup connection nipple	SA-NIP N006 G1/8-IG DN200	10.01.01.03522
PFYN 25	G1/8-IG	Suction cup connection nipple	SA-NIP N007 G1/8-IG DN350	10.01.01.03523
PFYN 30	G1/8-IG	Suction cup connection nipple	SA-NIP N007 G1/8-IG DN350	10.01.01.03523
PFYN 35	G1/8-IG	Suction cup connection nipple	SA-NIP N007 G1/8-IG DN350	10.01.01.03523
PFYN 40	G1/8-IG	Suction cup connection nipple	SA-NIP N007 G1/8-IG DN350	10.01.01.03523
PFYN 50	G1/8-IG	Suction cup connection nipple	SA-NIP N008 G1/8-IG DN350	10.01.01.03524
PFYN 60	G1/4-IG	Suction cup connection nipple (inst)	SA-NIP N009 G1/4-IG	10.01.01.10096
PFYN 80	G1/4-IG	Suction cup connection nipple (inst)	SA-NIP N009 G1/4-IG	10.01.01.10096
PFYN 95	G1/4-IG	Suction cup connection nipple (inst)	SA-NIP N009 G1/4-IG	10.01.01.10096
PFYN 120	G1/2-IG	Suction cup connection nipple (inst)	SA-NIP N010 G1/2-IG	10.01.01.00796
PFYN 150	G1/2-IG	Suction cup connection nipple (inst)	SA-NIP N010 G1/2-IG	10.01.01.00796
PFYN 200	G1/2-IG	Suction cup connection nipple (inst)	SA-NIP N010 G1/2-IG	10.01.01.00796



## Technical Data Flat Suction Cups PFYN

Type	Suction force [N]*	Volume [cm³]	Workpiece radius min. (convex) [mm]	Hose diameter (recom.) d [mm]**	Nipple family
PFYN 1	0.03	0.001	2	2	N 001
PFYN 1.5	0.06	0.001	2	2	N 002
PFYN 2	0.12	0.001	2	2	N 003
PFYN 3.5	0.42	0.002	8	2	N 003
PFYN 5	0.75	0.005	8	2	N 004
PFYN 6	1.20	0.008	8	2	N 004
PFYN 8	2.30	0.030	10	2	N 004
PFYN 10	4.00	0.070	13	2	N 004
PFYN 15	9.00	0.400	13	4	N 005
PFYN 20	15.50	0.800	20	4	N 006
PFYN 25	26.50	1.300	25	4	N 007
PFYN 30	34.00	1.300	40	4	N 007



Schmalz – The Company  
Vacuum Suction Cups  
Special Grippers  
Gripping Systems  
Clamping Systems  
Mounting Elements  
Vacuum Generators  
Valve Technology  
Switches and Monitoring  
Filters and Connections  
Services  
Contact  
Glossary  
Index of Products

# Flat Suction Cups PFYN

Suction area (Ø) from 1 mm to 200 mm

Schmalz - The Company  
 Vacuum Suction Cups  
 Special Grippers  
 Gripping Systems  
 Clamping Systems  
 Mounting Elements  
 Vacuum Generators  
 Valve Technology  
 Switches and Monitoring  
 Filters and Connections  
 Services  
 Contact  
 Glossary  
 Index of Products



## Technical Data Flat Suction Cups PFYN

Type	Suction force [N]*	Volume [cm³]	Workpiece radius min. (convex) [mm]	Hose diameter (recom.) d [mm]**	Nipple family
PFYN 35	44.00	2.700	50	4	N 007
PFYN 40	57.70	3.800	50	4	N 007
PFYN 50	91.00	7.000	75	4	N 008
PFYN 60	125.00	10.000	100	6	N 009
PFYN 80	260.00	25.000	150	6	N 009
PFYN 95	350.00	35.000	200	6	N 009
PFYN 120	540.00	77.800	300	9	N 010
PFYN 150	842.00	176.300	300	9	N 010
PFYN 200	1,498.00	427.000	400	9	N 010

\*The specified suction forces are theoretical values at a vacuum of -0.6 bar and with a smooth, dry workpiece surface - they do not include a safety factor

\*\*The recommended hose diameter refers to a hose length of approx. 2 m



## Design Data Flat Suction Cups PFYN

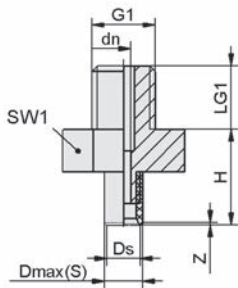

PFYN 1 - 1.5 AG

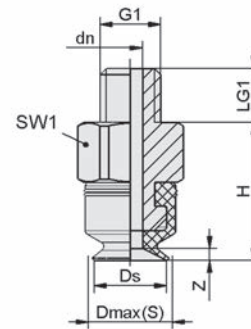

PFYN 2 - 10 AG

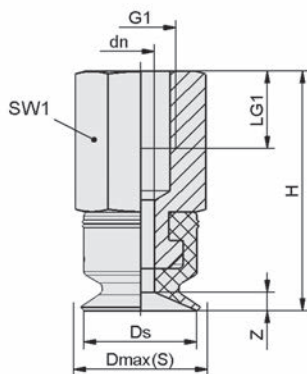

PFYN 5 - 10 IG

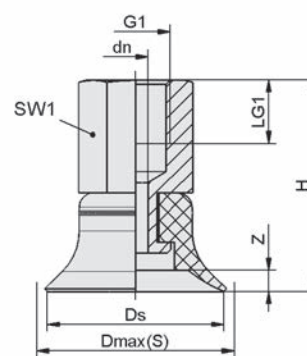

PFYN 15 - 50 IG



# Flat Suction Cups PFYN

Suction area ( $\varnothing$ ) from 1 mm to 200 mm



## Design Data Flat Suction Cups PFYN

PFYN 15 - 50 AG

PFYN 60 - 95 IG

PFYN 60 - 95 AG

PFYN 120 - 200 IG

PFG 1 - 1.5

PFG 2 - 10

PFG 1 - 1.5

PFG 2 - 10

- Vacuum Suction Cups
- Schmalz - The Company
- Special Grippers
- Gripping Systems
- Clamping Systems
- Mounting Elements
- Vacuum Generators
- Valve Technology
- Switches and Monitoring
- Filters and Connections
- Services
- Contact
- Glossary
- Index of Products

# Flat Suction Cups PFYN

Suction area (Ø) from 1 mm to 200 mm



## Design Data Flat Suction Cups PFYN

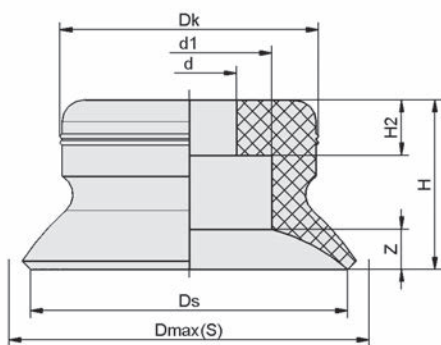

PFG 15 - 50

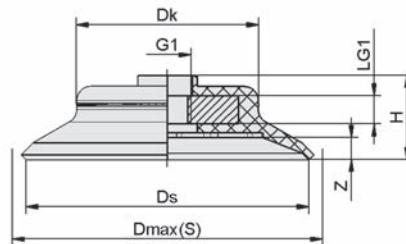

PFG 60 - 95

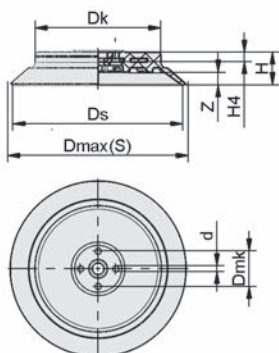

PFG 120 - 200

Type	dn [mm]	Dmax(S) [mm]*	Ds [mm]	G1	H [mm]	LG1 [mm]	SW1 [mm]	Z (Stroke) [mm]	
PFYN 1	M3-AG	0.4	1.2	1.00	M3-M	3.6	3.0	5	0.1
PFYN 1.5	M3-AG	0.7	1.8	1.50	M3-M	4.5	3.0	5	0.1
PFYN 2	M3-AG	1.0	2.5	2.00	M3-M	6.0	3.0	5	0.5
PFYN 3.5	M3-AG	1.0	4.0	3.50	M3-M	6.0	3.0	5	0.5
PFYN 5	M5-AG	1.5	5.5	5.00	M5-M	11.5	4.5	8	0.9
PFYN 5	M5-IG	1.5	5.5	5.00	M5-F	16.5	5.5	8	0.9
PFYN 6	M5-AG	2.0	6.5	6.00	M5-M	11.5	4.5	8	1.0
PFYN 6	M5-IG	2.0	6.5	6.00	M5-F	16.5	5.5	8	1.0
PFYN 8	M5-AG	2.0	9.0	8.00	M5-M	12.0	4.5	8	1.3
PFYN 8	M5-IG	2.0	9.0	8.00	M5-F	17.0	5.5	8	1.3
PFYN 10	M5-AG	2.0	11.5	10.00	M5-M	12.5	4.5	8	1.4
PFYN 10	M5-IG	2.0	11.5	10.00	M5-F	17.5	5.5	8	1.4
PFYN 10	G1/8-AG	2.0	11.5	10.00	G1/8"-M	12.5	8.0	14	1.4
PFYN 10	G1/8-IG	2.0	11.5	10.00	G1/8"-F	23.5	9.0	14	1.4



Schmalz - The Company  
 Vacuum Suction Cups  
 Special Grippers  
 Gripping Systems  
 Clamping Systems  
 Mounting Elements  
 Vacuum Generators  
 Valve Technology  
 Switches and Monitoring  
 Filters and Connections  
 Services  
 Contact  
 Glossary  
 Index of Products

# Flat Suction Cups PFYN

Suction area (Ø) from 1 mm to 200 mm



## Design Data Flat Suction Cups PFYN

Type	dn [mm]	Dmax(S) [mm]*	Ds [mm]	G1	H [mm]	LG1 [mm]	SW1 [mm]	Z (Stroke) [mm]	
PFYN 15	G1/8-AG	2.0	17.5	15.00	G1/8"-M	13.0	8.0	14	1.9
PFYN 15	G1/8-IG	2.0	17.5	15.00	G1/8"-F	24.0	9.0	14	1.9
PFYN 20	G1/8-AG	2.0	23.0	20.00	G1/8"-M	15.0	8.0	14	2.2
PFYN 20	G1/8-IG	2.0	23.0	20.00	G1/8"-F	26.0	9.0	14	2.2
PFYN 25	G1/8-AG	2.4	27.5	25.00	G1/8"-M	19.0	8.0	14	3.0
PFYN 25	G1/8-IG	3.5	27.5	25.00	G1/8"-F	30.0	9.0	14	3.0
PFYN 30	G1/8-AG	2.4	31.5	28.80	G1/8"-M	17.0	8.0	14	2.0
PFYN 30	G1/8-IG	3.5	31.5	28.80	G1/8"-F	28.0	9.0	14	2.0
PFYN 35	G1/8-AG	2.4	38.0	35.00	G1/8"-M	19.0	8.0	14	3.0
PFYN 35	G1/8-IG	3.5	38.0	35.00	G1/8"-F	30.0	9.0	14	3.0
PFYN 40	G1/8-AG	2.4	43.0	40.00	G1/8"-M	19.0	8.0	14	3.5
PFYN 40	G1/8-IG	3.5	43.0	40.00	G1/8"-F	30.0	9.0	14	3.5
PFYN 50	G1/8-AG	2.4	53.5	50.00	G1/8"-M	20.0	8.0	14	4.0
PFYN 50	G1/8-IG	3.5	53.5	50.00	G1/8"-F	31.0	9.0	14	4.0
PFYN 60	G1/4-AG	5.5	64.0	60.00	G1/4"-M	23.0	10.0	17	4.7
PFYN 60	G1/4-IG	5.5	64.0	60.00	G1/4"-F	39.0	11.0	17	4.7
PFYN 80	G1/4-AG	5.5	86.0	80.00	G1/4"-M	25.0	10.0	17	6.0
PFYN 80	G1/4-IG	5.5	86.0	80.00	G1/4"-F	41.5	11.0	17	6.0
PFYN 95	G1/4-AG	5.5	102.0	95.00	G1/4"-M	25.5	10.0	17	6.0
PFYN 95	G1/4-IG	5.5	102.0	95.00	G1/4"-F	41.5	11.0	17	6.0
PFYN 120	G1/2-IG	13.5	124.0	120.00	G1/2"-F	36.5	13.0	-	6.0
PFYN 150	G1/2-IG	13.5	158.0	147.50	G1/2"-F	45.5	13.0	-	9.0
PFYN 200	G1/2-IG	13.5	222.0	193.00	G1/2"-F	50.5	13.0	-	13.0

\*External dimension of the suction cup when it is pressed against the workpiece by the vacuum

Type*	d [mm]	d1 [mm]	Dk [mm]	Dmax(S) [mm]**	Dmk [mm]	Ds [mm]	G1	H [mm]	H2 [mm]	H3 [mm]	H4 [mm]	LG1 [mm]	Z (Stroke) [mm]
PFG 1	0.8	-	1.2	1.2	-	1.0	-	1.6	-	-	-	-	0.1
PFG 1.5	1.2	-	1.8	1.8	-	1.5	-	2.5	-	-	-	-	0.1
PFG 2	2.0	3.0	4.2	3.0	-	2.0	-	4.0	1.5	2.5	-	-	0.5
PFG 3.5	2.0	3.0	4.2	4.0	-	3.5	-	4.0	1.5	2.5	-	-	0.5
PFG 5	4.0	6.0	7.7	5.5	-	5.0	-	6.5	2.0	4.0	-	-	0.9
PFG 6	4.0	6.0	7.7	6.5	-	6.0	-	6.5	2.0	4.0	-	-	1.0
PFG 8	4.0	6.0	8.2	9.0	-	8.0	-	7.0	2.0	4.0	-	-	1.3
PFG 10	4.0	6.0	8.7	11.5	-	10.0	-	7.5	2.0	4.0	-	-	1.4
PFG 15	4.5	7.8	12.2	17.5	-	15.0	-	8.0	2.6	-	-	-	1.9
PFG 20	4.5	11.0	15.2	23.0	-	20.0	-	10.0	4.5	-	-	-	2.2
PFG 25	6.0	11.0	16.2	27.5	-	25.0	-	14.0	7.0	-	-	-	3.0
PFG 30	6.0	11.0	15.1	31.5	-	28.8	-	12.0	7.0	-	-	-	2.0
PFG 35	6.0	11.0	20.5	38.0	-	35.0	-	14.0	7.0	-	-	-	3.0
PFG 40	6.0	11.0	24.3	43.0	-	40.0	-	14.0	7.0	-	-	-	3.5
PFG 50	8.0	20.0	29.1	53.5	-	50.0	-	15.0	7.0	-	-	-	4.0
PFG 60	-	-	38.7	64.0	-	60.0	M10x1.25-F	18.0	-	-	-	6	4.7
PFG 80	-	-	52.3	86.0	-	80.0	M10x1.25-F	20.5	-	-	-	6	6.0
PFG 95	-	-	68.2	102.0	-	95.0	M10x1.25-F	19.0	-	-	-	6	6.0
PFG 120	7.3	-	89.5	124.0	40	120.0	-	23.5	-	-	8.5	-	6.0
PFG 150	7.0	-	104.5	158.0	40	147.5	-	31.0	-	-	11.0	-	9.0
PFG 200	7.0	-	142.5	222.0	40	193.0	-	37.0	-	-	11.0	-	13.0

\*Acceptable dimensional tolerances for rubber parts concerning to DIN ISO 3302-1 M3

\*\*External dimension of the suction cup when it is pressed against the workpiece by the vacuum



Schmalz – The Company  
Vacuum Suction Cups  
Special Grippers  
Gripping Systems  
Clamping Systems  
Mounting Elements  
Vacuum Generators  
Valve Technology  
Switches and Monitoring  
Filters and Connections  
Services  
Contact  
Glossary  
Index of Products

# Flat Suction Cups PFYN VU1

Suction area (Ø) from 15 mm to 95 mm



## Suitability for Industry Specific Applications

### Applications

- Round, flat suction cup for applications in multi-shift operations with very short cycle times
- Handling of oily metal sheets (automotive production), cardboard and sheets of wood
- Handling of extremely abrasive workpieces such as rough cardboard sheets



Flat Suction Cups PFYN VU1

### Design

- Robust, wear-resistant suction cup PFYN (3) with single sealing lip, consisting of suction cup PFG (2), made of Vulkollan VU1 and connection nipple (1)
- Suction cup connected positively to nipple; no turning even when handling heavy loads
- Within each nipple family, the replacement cups and nipples can be combined as desired

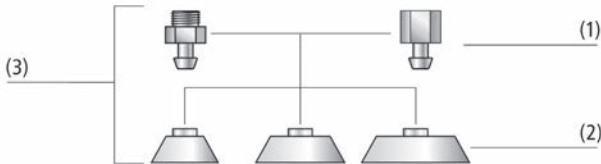

System Design Flat Suction Cups PFYN VU1

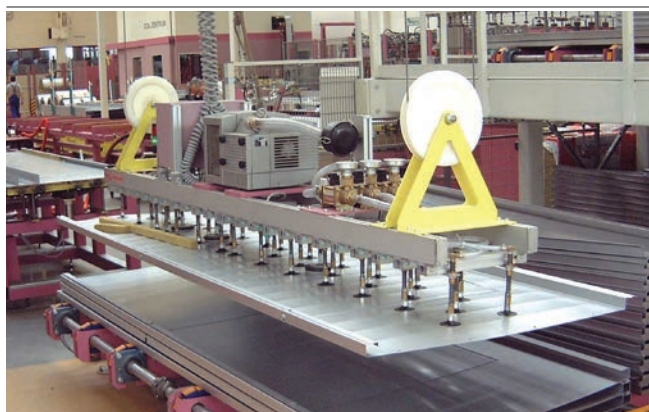

Flat suction cups PFYN VU1 being used for handling large sheet metal parts

### Our Highlights...

- Material Vulkollan VU1, very resistant to tearing
- Good resistance to chemicals
- Temperature resistance: -40° C to +80° C, short-term resistance up to +100° C
- Very low wear, about 10 - 12 mm<sup>3</sup> to DIN 53516
- Supports on the bottom

### Your Benefits...

- Extremely wear-resistant for very high loads
- Unaffected by oil (handling of sheet metal)
- Suitable for use at very low and high temperatures
- Lifetime up to 20 times higher, compared to standard NBR
- No permanent deformation of thin-walled workpieces

# Flat Suction Cups PFYN VU1

Suction area (Ø) from 15 mm to 95 mm



## Designation Code Flat Suction Cups PFYN VU1

<b>PFYN</b>	-	<b>80</b>	-	<b>VU1-72</b>	-	<b>G1/4-IG</b>
<b>1</b>		<b>2</b>		<b>3</b>		<b>4</b>

### 1 – Abbreviated designation

Code	Version
PFYN	Flat

### 2 – Suction area

Code	Diameter in mm
15...95	ø 15 to 95

### 3 – Material

Code	Material
VU1-72	VU1-72

### 4 – Connection

Code	Connection
G1/8-AG	G1/8-AG (AG = male (M))
G1/8-IG	G1/8-IG (IG = female (F))
G1/4-AG	G1/4-AG
G1/4-IG	G1/4-IG

Suction cup PFYN VU1 (elastomer part + connection nipple) is delivered assembled. The assembly consists of:

- Suction cup of type PFG VU1 – elastomer part, available in various diameters
- Connection nipple of type SA-NIP – available with various threads

Available spare parts: suction cup PFG VU1, connection nipple SA-NIP



## Ordering Data Flat Suction Cups PFYN VU1

Type*	Vacuum connection:			
	G1/8-AG	G1/8-IG	G1/4-AG	G1/4-IG
PFYN 15 VU1-72	10.01.01.00556	10.01.01.00557	-	-
PFYN 30 VU1-72	10.01.01.00550	10.01.01.00558	-	-
PFYN 50 VU1-72	-	-	10.01.01.00521	10.01.01.00547
PFYN 60 VU1-72	-	-	10.01.01.00608	10.01.01.00609
PFYN 80 VU1-72	-	-	10.01.01.00522	10.01.01.00524
PFYN 95 VU1-72	-	-	10.01.01.00523	10.01.01.00525

\*Additional material specifications at beginning of the section "Vacuum Suction Cups"



## Ordering Data Spare Parts Flat Suction Cups PFYN VU1

Type*	Spare Parts		Part no.
PFYN 15	Flat suction cup (round)	PFG 15 VU1-72 N005	10.01.01.00555
PFYN 30	Flat suction cup (round)	PFG 30 VU1-72 N007	10.01.01.00549
PFYN 50	Flat suction cup (round)	PFG 50 VU1-72 N011	10.01.01.00424
PFYN 60	Flat suction cup (round)	PFG 60 VU1-72 N011	10.01.01.00606
PFYN 80	Flat suction cup (round)	PFG 80 VU1-72 N012	10.01.01.00426
PFYN 95	Flat suction cup (round)	PFG 95 VU1-72 N012	10.01.01.00430

\*Additional material specifications at beginning of the section "Vacuum Suction Cups"

# Flat Suction Cups PFYN VU1

Suction area (Ø) from 15 mm to 95 mm

## Ordering Data Spare Parts Flat Suction Cups PFYN VU1

Type	Spare Parts		Part no.
PFYN 15 VU1-72 G1/8-AG	Suction cup connection nipple	SA-NIP N005 G1/8-AG DN200	10.01.01.03529
PFYN 15 VU1-72 G1/8-IG	Suction cup connection nipple	SA-NIP N005 G1/8-IG DN200	10.01.01.03521
PFYN 30 VU1-72 G1/8-AG	Suction cup connection nipple	SA-NIP N007 G1/8-AG DN240	10.01.01.03531
PFYN 30 VU1-72 G1/8-IG	Suction cup connection nipple	SA-NIP N007 G1/8-IG DN350	10.01.01.03523
PFYN 50 VU1-72 G1/4-AG	Suction cup connection nipple	SA-NIP N011 G1/4-AG DN350	10.01.01.10663
PFYN 50 VU1-72 G1/4-IG	Suction cup connection nipple	SA-NIP N011 G1/4-IG DN350	10.01.01.00412
PFYN 60 VU1-72 G1/4-AG	Suction cup connection nipple	SA-NIP N011 G1/4-AG DN350	10.01.01.10663
PFYN 60 VU1-72 G1/4-IG	Suction cup connection nipple	SA-NIP N011 G1/4-IG DN350	10.01.01.00412
PFYN 80 VU1-72 G1/4-AG	Suction cup connection nipple	SA-NIP N012 G1/4-AG DN500	10.01.01.10664
PFYN 80 VU1-72 G1/4-IG	Suction cup connection nipple	SA-NIP N011 G1/4-IG DN350	10.01.01.00412
PFYN 95 VU1-72 G1/4-AG	Suction cup connection nipple	SA-NIP N012 G1/4-AG DN500	10.01.01.10664
PFYN 95 VU1-72 G1/4-IG	Suction cup connection nipple	SA-NIP N012 G1/4-IG DN600	10.01.01.00528

## Technical Data Flat Suction Cups PFYN VU1

Type	Suction force [N]*		Volume [cm³]	Workpiece radius min. (convex) [mm]	Hose diameter (recom.) d [mm]**	Nipple family
PFYN 15 VU1-72	15	8.5	0.5	13	4	N 005
PFYN 30 VU1-72	30	32.0	1.7	30	4	N 007
PFYN 50 VU1-72	50	95.0	6.0	75	6	N 011
PFYN 60 VU1-72	60	130.0	15.0	75	6	N 011
PFYN 80 VU1-72	80	260.0	30.0	100	6	N 012
PFYN 95 VU1-72	95	350.0	42.0	140	6	N 012

\*The specified suction forces are theoretical values at a vacuum of -0.6 bar and with a smooth, dry workpiece surface - they do not include a safety factor

\*\*The recommended hose diameter refers to a hose length of approx. 2 m

## Design Data Flat Suction Cups PFYN VU1

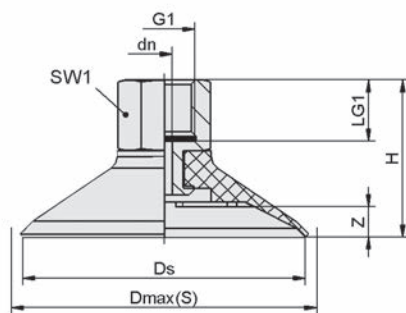

PFYN VU1 IG

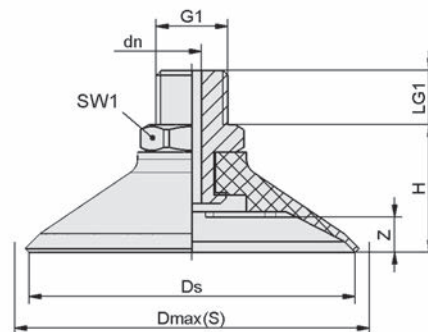

PFYN VU1 AG

Schmalz - The Company  
 Vacuum Suction Cups  
 Special Grippers  
 Gripping Systems  
 Clamping Systems  
 Mounting Elements  
 Vacuum Generators  
 Valve Technology  
 Switches and Monitoring  
 Filters and Connections  
 Services  
 Contact  
 Glossary  
 Index of Products

# Flat Suction Cups PFYN VU1

Suction area (Ø) from 15 mm to 95 mm



## Design Data Flat Suction Cups PFYN VU1

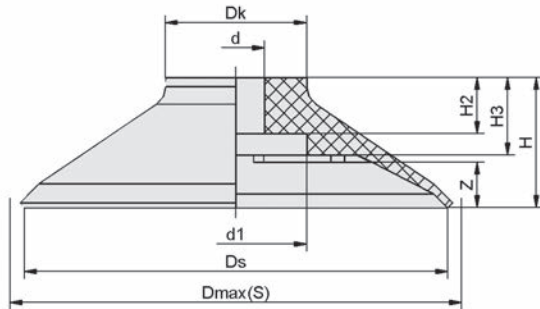

PFG VU1

Type*	dn [mm]	Dmax(S) [mm]**	Ds [mm]	G1	H [mm]	LG1 [mm]	SW1 [mm]	Z (Stroke) [mm]
PFYN 15 VU1-72 G1/8-AG	2.0	17.5	14.5	G1/8"-M	14.5	8	14	1.5
PFYN 15 VU1-72 G1/8-IG	2.0	17.5	14.5	G1/8"-F	25.5	9	14	1.5
PFYN 30 VU1-72 G1/8-AG	2.0	31.5	30.0	G1/8"-M	18.0	8	14	3.0
PFYN 30 VU1-72 G1/8-IG	2.0	31.5	30.0	G1/8"-F	29.0	9	14	3.0
PFYN 50 VU1-72 G1/4-AG	3.5	53.0	50.0	G1/4"-M	22.0	10	17	4.5
PFYN 50 VU1-72 G1/4-IG	3.5	53.0	50.0	G1/4"-F	32.0	12	17	4.5
PFYN 60 VU1-72 G1/4-AG	3.5	67.0	60.0	G1/4"-M	23.5	10	17	6.0
PFYN 60 VU1-72 G1/4-IG	3.5	67.0	60.0	G1/4"-F	33.5	12	17	6.0
PFYN 80 VU1-72 G1/4-AG	6.0	86.0	80.0	G1/4"-M	30.0	10	22	6.0
PFYN 80 VU1-72 G1/4-IG	6.0	86.0	80.0	G1/4"-F	40.0	12	22	6.0
PFYN 95 VU1-72 G1/4-AG	5.0	101.0	95.0	G1/4"-M	30.0	10	22	6.0
PFYN 95 VU1-72 G1/4-IG	6.0	101.0	95.0	G1/4"-F	40.0	12	22	6.0

\*Acceptable dimensional tolerances for rubber parts concerning to DIN ISO 3302-1 M3

\*\*External dimension of the suction cup when it is pressed against the workpiece by the vacuum

Type*	d [mm]	d1 [mm]	Dk [mm]	Dmax(S) [mm]**	Ds [mm]	H [mm]	H2 [mm]	H3 [mm]	Z (Stroke) [mm]
PFG 15 VU1-72 N005	4.5	8.5	11.5	17.0	14.5	9.5	2.5	4.5	1.5
PFG 30 VU1-72 N007	6.0	11.0	16.0	31.5	29.0	13.0	7.0	7.0	3.0
PFG 50 VU1-72 N011	8.0	13.0	18.0	53.0	49.0	17.0	8.0	11.0	4.5
PFG 60 VU1-72 N011	8.0	20.0	20.0	67.0	60.0	18.5	8.0	11.0	6.5
PFG 80 VU1-72 N012	12.0	25.0	52.3	86.0	80.0	25.0	12.0	17.5	6.0
PFG 95 VU1-72 N012	12.0	25.0	31.0	101.0	95.0	25.0	12.0	16.5	6.0

\*Acceptable dimensional tolerances for rubber parts concerning to DIN ISO 3302-1 M3

\*\*External dimension of the suction cup when it is pressed against the workpiece by the vacuum

# Suction Plates SPU

Suction area (Ø) from 100 mm to 400 mm



## Suitability for Industry Specific Applications

### Applications

- Round suction cup for handling of smooth, flat workpieces
- Series SPU B with thicker sealing lip: handling of workpieces with a slightly rough surface, such as wood or scaly metal sheets
- Series SPU AE with integrated peeling insert: handling of thin metal sheets (approx. 1.0 - 2.5 mm); overcomes the self-adhesion between the sheets
- Series SPU TV with touch valve: deactivation of unused suction cups to prevent the entry of unwanted air



Suction Plates SPU

### Design

- Suction cup SPU consisting of sealing ring (3) and aluminum support plate (1)
- Sealing ring clipped securely onto support plate with positive locking
- Internal sealing edge (4) for better sealing on slightly rough surfaces
- Side vacuum connector (2) normally sealed with a plug (glued into position for extra safety)
- Series SPU TV: touch valve already installed
- Series SPU AE: peeling insert on the bottom side already installed

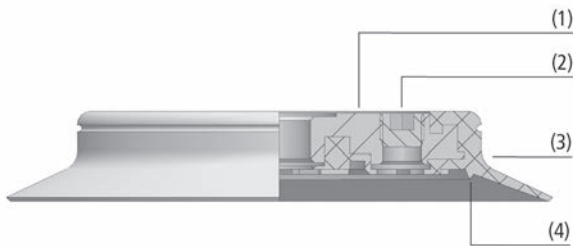

System Design Suction Plates SPU

### Our Highlights...

- Supports on the bottom
- Low internal volume
- Wide range of diameters
- Optimum shape

### Your Benefits...

- No permanent deformation of thin-walled workpieces
- Very short cycle times
- Wide range of versions for many different workpieces
- High suction force in spite of small dimensions



Suction plates SPU being used for handling shaped sheet metal parts

Schmalz – The Company

Vacuum Suction Cups

Special Grippers

Gripping Systems

Clamping Systems

Mounting Elements

Vacuum Generators

Valve Technology

Switches and Monitoring

Filters and Connections

Services

Contact

Glossary

Index of Products





# Suction Plates SPU

Suction area (Ø) from 100 mm to 400 mm

## Designation Code Suction Plates SPU



### 1 – Abbreviated designation

Code	Version
SPU	Flat

### 2 – Suction area

Code	Diameter in mm
100...400	ø 100 to 400

### 3 – Material

Code	Material
NBR-55	Nitrile caoutchuc
SI-60	Silicone

### 4 – Connection

Code	Connection
G1/4-IG	G1/4-IG (IG = female (F))
G1/2-IG	G1/2-IG

### 5 – Product addition

Code	Type
AE	Peeling insert
B	Steep sealing lip
TV	Touch valve

Suction plate SPU (sealing ring + support plate) is delivered assembled. The assembly consists of:

- Sealing ring of type DR-SPU – elastomer part, available in various diameters
- Aluminum support plate, available with various threads
- Optional product addition: touch valve, steep sealing lip, peeling insert

Available spare parts: sealing ring DR-SPU, touch valve TV

## Ordering Data Suction Plates SPU

Type	Suction cup material with ShA: *				
	NBR-55				
				SI-60	
SPU 100	G1/4-IG	-		10.01.01.01107	10.01.01.01108
SPU 125	G1/4-IG	-		10.01.01.01102	10.01.01.01103
SPU 125	G1/4-IG	AE		10.01.01.01159	10.01.01.01160
SPU 125	G1/4-IG	TV		10.01.01.01157	10.01.01.01158
SPU 160	G1/2-IG	-		10.01.01.01116	10.01.01.01117
SPU 160	G1/2-IG	AE		10.01.01.01155	10.01.01.01156
SPU 160	G1/2-IG	TV		10.01.01.01153	10.01.01.01154
SPU 210	G1/2-IG	-		10.01.01.01092	10.01.01.01093
SPU 210	G1/2-IG	AE		10.01.01.01151	10.01.01.01152
SPU 210	G1/2-IG	B		10.01.01.10552	-
SPU 210	G1/2-IG	TV		10.01.01.01149	10.01.01.01150
SPU 250	G1/2-IG	-		10.01.01.01097	10.01.01.01098
SPU 250	G1/2-IG	B		10.01.01.10589	-
SPU 250	G1/2-IG	TV		10.01.01.01209	10.01.01.01210
SPU 300	G1/2-IG	-		10.01.01.01134	10.01.01.01135
SPU 360	G1/2-IG	B		10.01.01.10588	-
SPU 400	G1/2-IG	-		10.01.01.01138	-

\*Additional material specifications at beginning of the section "Vacuum Suction Cups"

# Suction Plates SPU

Suction area (Ø) from 100 mm to 400 mm



## Ordering Data Spare Parts Suction Plates SPU

Type	Spare Parts		Part no.
SPU 100 NBR-55 G1/4-IG	Sealing ring for SPU suction plate	DR-SPU 100 NBR-55	10.01.01.01104
SPU 100 SI-60 G1/4-IG	Sealing ring for SPU suction plate	DR-SPU 100 SI-55	10.01.01.01105
SPU 125 NBR-55 G1/4-IG	Sealing ring for SPU suction plate	DR-SPU 125 NBR-55	10.01.01.01099
SPU 125 NBR-55 G1/4-IG AE	Sealing ring for SPU suction plate	DR-SPU 125 NBR-55	10.01.01.01099
SPU 125 NBR-55 G1/4-IG TV	Sealing ring for SPU suction plate	DR-SPU 125 NBR-55	10.01.01.01099
SPU 125 SI-60 G1/4-IG	Sealing ring for SPU suction plate	DR-SPU 125 SI-55	10.01.01.01100
SPU 125 SI-60 G1/4-IG AE	Sealing ring for SPU suction plate	DR-SPU 125 SI-55	10.01.01.01100
SPU 125 SI-60 G1/4-IG TV	Sealing ring for SPU suction plate	DR-SPU 125 SI-55	10.01.01.01100
SPU 160 NBR-55 G1/2-IG	Sealing ring for SPU suction plate	DR-SPU 160 NBR-55	10.01.01.01111
SPU 160 NBR-55 G1/2-IG AE	Sealing ring for SPU suction plate	DR-SPU 160 NBR-55	10.01.01.01111
SPU 160 NBR-55 G1/2-IG TV	Sealing ring for SPU suction plate	DR-SPU 160 NBR-55	10.01.01.01111
SPU 160 SI-60 G1/2-IG	Sealing ring for SPU suction plate	DR-SPU 160 SI-55	10.01.01.01112
SPU 160 SI-60 G1/2-IG AE	Sealing ring for SPU suction plate	DR-SPU 160 SI-55	10.01.01.01112
SPU 160 SI-60 G1/2-IG TV	Sealing ring for SPU suction plate	DR-SPU 160 SI-55	10.01.01.01112
SPU 210 NBR-55 G1/2-IG	Sealing ring for SPU suction plate	DR-SPU 210 NBR-55	10.01.01.01089
SPU 210 NBR-55 G1/2-IG AE	Sealing ring for SPU suction plate	DR-SPU 210 NBR-55	10.01.01.01089
SPU 210 NBR-55 G1/2-IG B	Sealing ring for SPU suction plate	DR-SPU 210 NBR-55 B	10.01.01.10502
SPU 210 NBR-55 G1/2-IG TV	Sealing ring for SPU suction plate	DR-SPU 210 NBR-55	10.01.01.01089
SPU 210 SI-60 G1/2-IG	Sealing ring for SPU suction plate	DR-SPU 210 SI-55	10.01.01.01090
SPU 210 SI-60 G1/2-IG AE	Sealing ring for SPU suction plate	DR-SPU 210 SI-55	10.01.01.01090
SPU 210 SI-60 G1/2-IG TV	Sealing ring for SPU suction plate	DR-SPU 210 SI-55	10.01.01.01090
SPU 250 NBR-55 G1/2-IG	Sealing ring for SPU suction plate	DR-SPU 250 NBR-55	10.01.01.01094
SPU 250 NBR-55 G1/2-IG B	Sealing ring for SPU suction plate	DR-SPU 250 NBR-55 B	10.01.01.10579
SPU 250 NBR-55 G1/2-IG TV	Sealing ring for SPU suction plate	DR-SPU 250 NBR-55	10.01.01.01094
SPU 250 SI-60 G1/2-IG	Sealing ring for SPU suction plate	DR-SPU 250 SI-55	10.01.01.01095
SPU 250 SI-60 G1/2-IG TV	Sealing ring for SPU suction plate	DR-SPU 250 SI-55	10.01.01.01095
SPU 300 NBR-55 G1/2-IG	Sealing ring for SPU suction plate	DR-SPU 300 NBR-55	10.01.01.01131
SPU 300 SI-60 G1/2-IG	Sealing ring for SPU suction plate	DR-SPU 300 SI-55	10.01.01.01132
SPU 360 NBR-55 G1/2-IG B	Sealing ring for SPU suction plate	DR-SPU 360 NBR-55 B	10.01.01.10584
SPU 400 NBR-55 G1/2-IG	Sealing ring for SPU suction plate	DR-SPU 400 NBR-55	10.01.01.01136

Type	Spare Parts		Part no.
SPU 125 TV	Touch Valve	TV G1/4-AG 13	10.05.10.00061
SPU 160 TV	Touch Valve	TV G1/4-AG 13	10.05.10.00061
SPU 210 TV	Touch Valve	TV G1/4-AG 13	10.05.10.00061
SPU 250 TV	Touch Valve	TV G1/2-AG 13	10.05.10.00038



## Technical Data Suction Plates SPU

Type	Suction force [N]*	Suction force d2 [N]**	Volume [cm³]	Workpiece radius min. (convex) [mm]	Hose diameter (recom.) d [mm]***
SPU 100 -	425	185	45	130	9
SPU 125 -	660	365	76	220	9
SPU 125 AE	660	365	77	-	9
SPU 125 TV	660	365	76	220	9
SPU 160 -	1,090	600	142	350	12
SPU 160 AE	1,090	600	151	-	12
SPU 160 TV	1,090	600	142	350	9
SPU 210 -	1,870	1,250	226	750	12



# Suction Plates SPU

Suction area (Ø) from 100 mm to 400 mm



## Technical Data Suction Plates SPU

Type			Suction force [N]*	Suction force d2 [N]**	Volume [cm³]	Workpiece radius min. (convex) [mm]	Hose diameter (recom.) d [mm]***
SPU 210	AE		1,870	1,250	194	-	12
SPU 210	B		1,870	1,190	321	750	12
SPU 210	TV		1,870	1,250	192	750	9
SPU 250	-		2,650	1,940	370	2,200	12
SPU 250	B		2,650	1,940	512	1,500	12
SPU 250	TV		2,650	1,940	371	2,200	12
SPU 300	-		3,810	3,010	491	3,500	12
SPU 360	B		5,500	4,730	1,289	3,000	12
SPU 400	-		6,780	5,870	890	6,500	12

\*The specified suction forces are theoretical values at a vacuum of -0.6 bar and with a smooth, dry workpiece surface - they do not include a safety factor

\*\*Suction force referred to the sealing-edge diameter d2

\*\*\*The recommended hose diameter refers to a hose length of approx. 2 m



## Design Data Suction Plates SPU

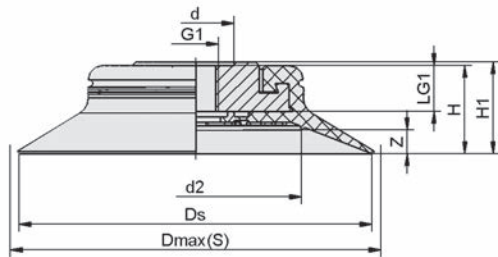

SPU 100

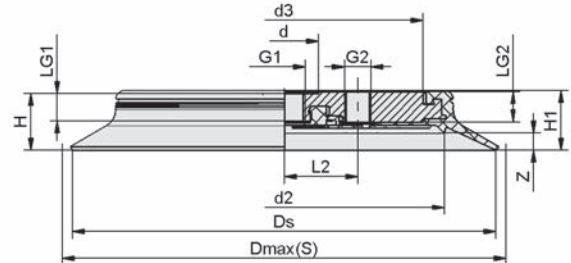

SPU 125 - 400 (B)

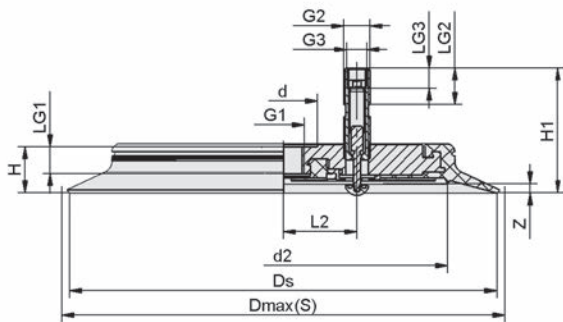

SPU 125 - 250 TV

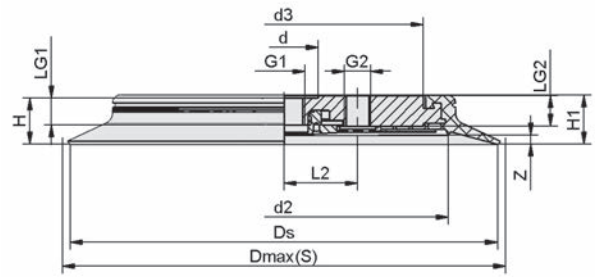

SPU 125 - 210 AE

# Suction Plates SPU

Suction area (Ø) from 100 mm to 400 mm



## Design Data Suction Plates SPU

Type*	d [mm]	d2 [mm]	d3 [mm]	Dmax(S) [mm]**	Ds [mm]	G1	G2	G3	H [mm]	H1 [mm]	L2 [mm]	LG1 [mm]	LG2 [mm]	LG3 [mm]	Z (Stroke) [mm]		
SPU 100	G1/4-IG	-	22	60	-	108	100	G1/4"-F	-	-	25.0	26.0	-	13.0	-	-	7
SPU 125	G1/4-IG	-	22	83	61.0	132	125	G1/4"-F	G1/4"-F	-	25.0	26.0	22.0	13.0	14	-	7
SPU 125	G1/4-IG	AE	22	83	61.0	132	125	G1/4"-F	G1/4"-F	-	25.0	26.0	22.0	13.0	14	-	7
SPU 125	G1/4-IG	TV	22	83	-	132	125	G1/4"-F	G1/4"-M	G1/8"-F	25.0	62.0	22.0	13.0	36	7	7
SPU 160	G1/2-IG	-	34	113	88.0	170	160	G1/2"-F	G1-1/4"-F	-	25.0	26.5	36.5	13.5	15	-	7
SPU 160	G1/2-IG	AE	34	113	88.0	170	160	G1/2"-F	G1/4"-F	-	25.0	26.5	36.5	13.5	15	-	7
SPU 160	G1/2-IG	TV	34	113	-	170	160	G1/2"-F	G1/4"-M	G1/8"-F	25.0	62.0	36.5	13.5	18	10	7
SPU 210	G1/2-IG	-	34	163	138.0	220	210	G1/2"-F	G1/4"-F	-	25.0	26.5	36.5	13.5	15	-	5
SPU 210	G1/2-IG	AE	34	163	138.0	220	210	G1/2"-F	G1/4"-F	-	25.0	26.5	36.5	13.5	15	-	5
SPU 210	G1/2-IG	B	34	159	138.0	220	210	G1/2"-F	G1/4"-F	-	29.0	29.5	36.5	13.5	15	-	10
SPU 210	G1/2-IG	TV	34	163	-	220	210	G1/2"-F	G1/4"-M	G1/8"-F	25.0	62.0	36.5	13.5	38	10	5
SPU 250	G1/2-IG	-	34	203	178.0	265	250	G1/2"-F	G1/2"-F	-	25.0	26.5	76.0	13.5	15	-	7
SPU 250	G1/2-IG	B	34	203	178.0	265	250	G1/2"-F	G1/2"-F	-	29.0	30.0	76.0	13.5	15	-	11
SPU 250	G1/2-IG	TV	34	203	-	265	250	G1/2"-F	G1/2"-M	G3/8"-F	25.0	65.5	76.0	13.5	39	12	7
SPU 300	G1/2-IG	-	34	253	226.5	320	300	G1/2"-F	G1/2"-F	-	25.0	26.5	76.0	13.5	15	-	6
SPU 360	G1/2-IG	B	-	309	275.0	385	360	G1/2"-F	G1/2"-F	-	35.0	35.5	86.0	17.0	17	-	12
SPU 400	G1/2-IG	-	-	349	315.0	430	400	G1/2"-F	G1/2"-F	-	28.5	29.0	86.0	15.5	17	-	6

\*Acceptable dimensional tolerances for rubber parts concerning to DIN ISO 3302-1 M3

\*\*External dimension of the suction cup when it is pressed against the workpiece by the vacuum



- Vacuum Suction Cups
- Vacuum Generators
- Valve Technology
- Switches and Monitoring
- Filters and Connections
- Services
- Contact
- Glossary
- Index of Products

# Suction Plates SPK

Suction area (Ø) from 55 mm to 250 mm



Suction Plates SPK

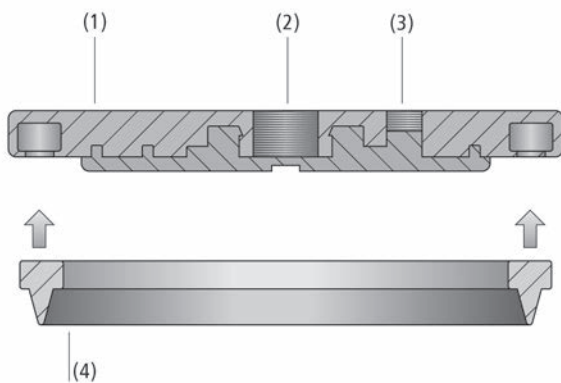

System Design Suction Plates SPK



Suction plates SPK being used for handling corrugated sheet metal

## Suitability for Industry Specific Applications

### Applications

- Round suction plate for handling of objects with very rough or structured surfaces (such as ornamental glass, checker plate, broken natural stone, etc.)
- Deactivation of unused suction cups by touch valves (accessory)

### Design

- Robust and wear-resistant suction plate SPK, consisting of flexible EPDM sealing ring (4) made of EPDM and aluminum base plate (1)
- Sealing ring without seams
- Sealing ring is securely clipped into the base plate
- When worn, the sealing ring can be replaced separately
- Lower side of base plate with elastomer insert to prevent damage to workpieces
- Threaded hole for vacuum connection (2) or touch valve (off-centre) (3) sealed with a plug when delivered

### Our Highlights...

- Sealing lip made of flexible EPDM
- Sealing ring clipped securely into the mounting plate
- Support on the bottom

- Low internal volume
- Wide range of different diameters

### Your Benefits...

- Optimal adaptation to structured surfaces
- Quick replacement of the sealing element
- No permanent deformation of thin-walled workpieces
- Very short cycle times
- Wide range of cups for handling different workpieces



# Suction Plates SPK

Suction area (Ø) from 55 mm to 250 mm

## Designation Code Suction Plates SPK



### 1 - Abbreviated designation

Code	Version
SPK	Flat

### 2 - Suction area

Code	Diameter in mm
55...250	ø 55 to 250

### 3 - Material

Code	Material
MOS EPDM-15	Foam rubber made of ethylene-propylene-cautchuc

### 4 - Connection

Code	Connection
G1/4-IG	G1/4-IG (IG = female (F))
G1/2-IG	G1/2-IG

Suction plate SPK (sealing ring + support plate) is delivered assembled. The assembly consists of:

- Sealing ring of type DR-SPK – elastomer part, available in various diameters
- Aluminum support plate, available with various threads

Available spare parts: sealing ring DR-SPK

Available accessories: touch valve

## Ordering Data Suction Plates SPK

Type	Part no.
SPK 55 MOS EPDM-15 G1/4-IG	10.01.01.12060
SPK 80 MOS EPDM-15 G1/4-IG	10.01.01.12061
SPK 110 MOS EPDM-15 G1/2-IG	10.01.01.12062
SPK 160 MOS EPDM-15 G1/2-IG	10.01.01.12063
SPK 200 MOS EPDM-15 G1/2-IG	10.01.01.12064
SPK 250 MOS EPDM-15 G1/2-IG	10.01.01.12065

## Ordering Data Spare Parts Suction Plates SPK

Type	Spare Parts	Part no.	
SPK 55 MOS EPDM-15 G1/4-IG	Sealing ring for SPK suction plate	DR-SPK 55 MOS EPDM-15	10.01.01.12072
SPK 80 MOS EPDM-15 G1/4-IG	Sealing ring for SPK suction plate	DR-SPK 80 MOS EPDM-15	10.01.01.12073
SPK 110 MOS EPDM-15 G1/2-IG	Sealing ring for SPK suction plate	DR-SPK 110 MOS EPDM-15	10.01.01.12074
SPK 160 MOS EPDM-15 G1/2-IG	Sealing ring for SPK suction plate	DR-SPK 160 MOS EPDM-15	10.01.01.12075
SPK 200 MOS EPDM-15 G1/2-IG	Sealing ring for SPK suction plate	DR-SPK 200 MOS EPDM-15	10.01.01.12076
SPK 250 MOS EPDM-15 G1/2-IG	Sealing ring for SPK suction plate	DR-SPK 250 MOS EPDM-15	10.01.01.12077

## Ordering Data Accessories Suction Plates SPK

Type	Accessories	Part no.	
SPK 55 MOS EPDM-15 G1/4-IG	-	-	
SPK 80 MOS EPDM-15 G1/4-IG	Touch Valve	TV G1/4-AG 13	10.05.10.00061
SPK 110 MOS EPDM-15 G1/2-IG	Touch Valve	TV G1/4-AG 13	10.05.10.00061
SPK 160 MOS EPDM-15 G1/2-IG	Touch Valve	TV G1/4-AG 13	10.05.10.00061
SPK 200 MOS EPDM-15 G1/2-IG	Touch Valve	TV G1/2-AG 13	10.05.10.00038
SPK 250 MOS EPDM-15 G1/2-IG	Touch Valve	TV G1/2-AG 13	10.05.10.00038

# Suction Plates SPK

Suction area (Ø) from 55 mm to 250 mm



## Technical Data Suction Plates SPK

Type	Suction force [N]*	Volume [cm³]	Workpiece radius min. (convex) [mm]	Hose diameter (recom.) d [mm]**
SPK 55 MOS EPDM-15 G1/4-IG	121	12	250	9
SPK 80 MOS EPDM-15 G1/4-IG	256	22	400	9
SPK 110 MOS EPDM-15 G1/2-IG	471	68	500	12
SPK 160 MOS EPDM-15 G1/2-IG	1,060	129	1,000	12
SPK 200 MOS EPDM-15 G1/2-IG	1,700	199	1,600	12
SPK 250 MOS EPDM-15 G1/2-IG	2,714	291	2,600	12

\*The specified suction forces are theoretical values at a vacuum of -0.6 bar and with a smooth, dry workpiece surface - they do not include a safety factor

\*\*The recommended hose diameter refers to a hose length of approx. 2 m



## Design Data Suction Plates SPK

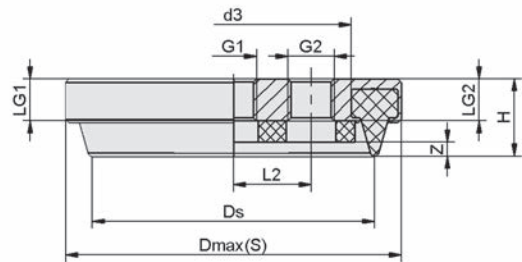
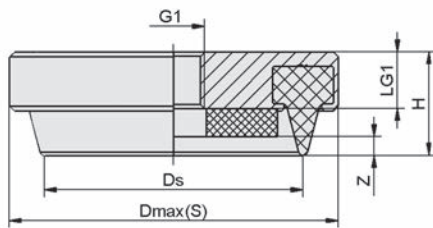

SPK 55

SPK 80 - 250

Type*	d3 [mm]	Dmax(S) [mm]**	Ds [mm]	G1	G2***	H [mm]	LG1 [mm]	LG2 [mm]	L2 [mm]	Z (Stroke) [mm]
SPK 55 MOS EPDM-15 G1/4-IG	-	70.0	55	G1/4"-F	-	22.0	11.5	-	-	4
SPK 80 MOS EPDM-15 G1/4-IG	66.8	95.2	80	G1/4"-F	G1/4"-F	22.0	11.5	11.5	22.0	4
SPK 110 MOS EPDM-15 G1/2-IG	96.0	130.0	110	G1/2"-F	G1/4"-F	25.5	14.5	14.5	36.5	6
SPK 160 MOS EPDM-15 G1/2-IG	148.0	179.0	159	G1/2"-F	G1/4"-F	25.5	14.5	14.5	36.5	6
SPK 200 MOS EPDM-15 G1/2-IG	185.0	219.0	199	G1/2"-F	G1/2"-F	25.5	14.5	14.5	76.0	6
SPK 250 MOS EPDM-15 G1/2-IG	235.0	269.0	249	G1/2"-F	G1/2"-F	25.5	14.5	14.5	76.0	6

\*Acceptable dimensional tolerances for rubber parts concerning to DIN ISO 3302-1 M3

\*\*External dimension of the suction cup when it is pressed against the workpiece by the vacuum

\*\*\*A plug is fitted in this connection in the factory

# Flat Suction Cups SGON

Suction area (LxW) from 4 x 2 mm to 90 x 30 mm



## Suitability for Industry Specific Applications

### Applications

- Oval and flat suction cup for handling of narrow workpieces, including curved objects, such as sections, pipes, packaging materials
- Handling of frame elements, such as doors and windows
- Considerably higher suction force than round, flat suction cups when handling narrow workpieces

### Design

- Robust, wear-resistant suction cup SGON (3) with single sealing lip, consisting of suction cup SGO (2) and connection nipple (1)
- Nipple plugged into cup
- Cups of the size 24 x 8 mm and larger are additionally secured with a two-ear clamp to prevent rotation
- Within each nipple family, the replacement cups and nipples can be combined as desired

Schmalz – The Company  
Vacuum Suction Cups  
Special Grippers  
Gripping Systems  
Clamping Systems  
Mounting Elements  
Vacuum Generators  
Valve Technology  
Switches and Monitoring  
Filters and Connections  
Services  
Contact  
Glossary  
Index of Products



Flat Suction Cups SGON

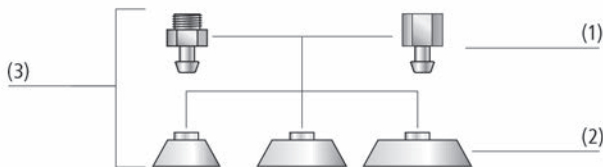

System Design Flat Suction Cups SGON

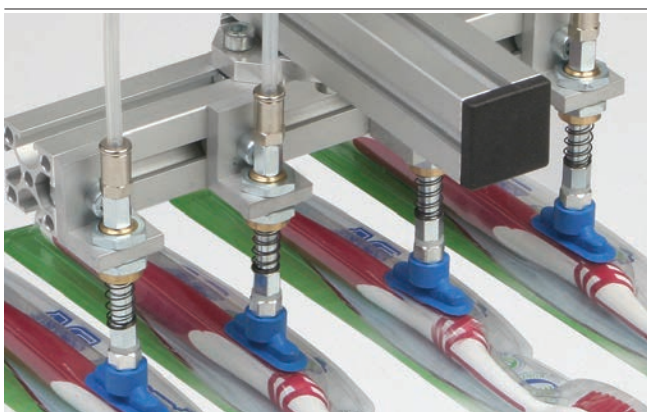

Flat suction cups SGON being used for handling blister packaging

### Our Highlights...

- Oval, flat suction cup
- Cups of the size 24 x 8 mm and larger additionally secured with a two-ear clamp
- Optimum shape
- Supports on the bottom

### Your Benefits...

- For long (sections, pipes) or flat workpieces with bars
- Protection against unwanted rotation during use
- High suction force in spite of small dimensions
- No permanent deformation of thin-walled workpieces





# Flat Suction Cups SGON

Suction area (LxW) from 4 x 2 mm to 90 x 30 mm



## Designation Code Flat Suction Cups SGON

<b>SGON</b>	-	<b>30x10</b>	-	<b>SI-60</b>	-	<b>G1/8-IG</b>
<b>1</b>		<b>2</b>		<b>3</b>		<b>4</b>

### 1 – Abbreviated designation

Code	Version
SGON	Flat, oval

### 2 – Suction area

Code	LxW in mm
4x2...90x30	4x2 to 90x30

### 3 – Material

Code	Material
HT1-60	High temperature material
NBR-55	Nitrile caoutchuc
NBR-60	Nitrile caoutchuc
NBR-70	Nitrile caoutchuc
NBR-AS-55	Nitrile caoutchuc
NBR-AS-60	Nitrile caoutchuc
SI-60	Silicone
SI-65	Silicone
SI-70	Silicone

### 4 – Connection

Code	Connection
M3-AG	M3-AG (AG = male (M))
M5-AG	M5-AG
M5-IG	M5-IG (IG = female (F))
G1/8-AG	G1/8-AG
G1/8-IG	G1/8-IG
G1/4-AG	G1/4-AG
G1/4-IG	G1/4-IG

Suction cup SGON (elastomer part + connection nipple) is delivered unassembled. The delivery consists of:

- Suction cup of type SGO – elastomer part, available in various dimensions (LxW) and materials
- Connection nipple of type SA-NIP – available with various threads
- Cups of the size 24 x 8 mm and larger are delivered with a two-ear clamp

Available spare parts: suction cup SGO, connection nipple SA-NIP, two-ear clamp



## Ordering Data Flat Suction Cups SGON

Type	Suction cup material with ShA: *						
			HT1-60	NBR-55	NBR-60	NBR-70	NBR-AS-55
SGON	4x2	M3-AG	10.01.05.00404	-	10.01.01.00564	-	-
SGON	7x3.5	M3-AG	10.01.05.00405	-	10.01.01.00489	-	-
SGON	12x4	M5-AG	10.01.05.00406	10.01.05.00236	-	-	10.01.05.00238
SGON	15x5	M5-AG	10.01.05.00407	-	10.01.05.00106	-	-
SGON	15x5	M5-IG	10.01.05.00418	-	10.01.05.00105	-	-
SGON	18x6	M5-AG	10.01.05.00408	-	10.01.05.00104	-	-
SGON	18x6	M5-IG	10.01.05.00419	-	10.01.05.00103	-	-
SGON	24x8	G1/8-AG	10.01.05.00409	-	10.01.05.00102	-	-
SGON	24x8	G1/8-IG	10.01.05.00420	-	10.01.05.00101	-	-
SGON	30x10	G1/8-AG	10.01.05.00410	-	10.01.05.00100	-	-
SGON	30x10	G1/8-IG	10.01.05.00421	-	10.01.05.00099	-	-
SGON	45x15	G1/4-AG	10.01.05.00411	-	10.01.05.00098	-	-
SGON	45x15	G1/4-IG	10.01.05.00422	-	10.01.05.00097	-	-
SGON	60x20	G1/4-AG	10.01.05.00412	-	10.01.05.00096	-	-
SGON	60x20	G1/4-IG	10.01.05.00423	-	10.01.05.00095	-	-
SGON	75x25	G1/4-AG	10.01.05.00413	-	10.01.05.00094	-	-
SGON	75x25	G1/4-IG	10.01.05.00424	-	10.01.05.00093	-	-
SGON	90x30	G1/4-AG	-	-	-	10.01.05.00092	-
SGON	90x30	G1/4-IG	-	-	-	10.01.05.00091	-

\*Additional material specifications at beginning of the section "Vacuum Suction Cups"



Schmalz – The Company

Vacuum Suction Cups

Special Grippers

Gripping Systems

Clamping Systems

Mounting Elements

Vacuum Generators

Valve Technology

Switches and Monitoring

Filters and Connections

Services

Contact

Glossary

Index of Products

# Flat Suction Cups SGON

Suction area (LxW) from 4 x 2 mm to 90 x 30 mm



## Ordering Data Flat Suction Cups SGON

Type	Suction cup material with ShA: *				
	NBR-AS-60	SI-60	SI-65	SI-70	
SGON 4x2 M3-AG	-	10.01.01.00565	-	-	
SGON 7x3.5 M3-AG	10.01.05.00228	10.01.01.00567	-	-	
SGON 12x4 M5-AG	-	-	10.01.01.00221	-	
SGON 15x5 M5-AG	10.01.05.00229	10.01.05.00120	-	-	
SGON 15x5 M5-IG	-	10.01.05.00119	-	-	
SGON 18x6 M5-AG	10.01.05.00230	10.01.05.00118	-	-	
SGON 18x6 M5-IG	-	10.01.05.00117	-	-	
SGON 24x8 G1/8-AG	10.01.05.00231	10.01.05.00088	-	-	
SGON 24x8 G1/8-IG	-	10.01.05.00087	-	-	
SGON 30x10 G1/8-AG	-	10.01.05.00116	-	-	
SGON 30x10 G1/8-IG	-	10.01.05.00115	-	-	
SGON 45x15 G1/4-AG	-	10.01.05.00114	-	-	
SGON 45x15 G1/4-IG	-	10.01.05.00113	-	-	
SGON 60x20 G1/4-AG	-	10.01.05.00112	-	-	
SGON 60x20 G1/4-IG	-	10.01.05.00111	-	-	
SGON 75x25 G1/4-AG	-	10.01.05.00110	-	-	
SGON 75x25 G1/4-IG	-	10.01.05.00109	-	-	
SGON 90x30 G1/4-AG	-	-	-	-	10.01.05.00108
SGON 90x30 G1/4-IG	-	-	-	-	10.01.05.00107

\*Additional material specifications at beginning of the section "Vacuum Suction Cups"



## Ordering Data Spare Parts Flat Suction Cups SGON

Type	Suction cup material with ShA: *				
	FPM-50	HT1-60	NBR-55	NBR-60	NBR-70
SGO 4x2	-	10.01.05.00426	-	10.01.01.00456	-
SGO 7x3.5	-	10.01.05.00427	-	10.01.01.00488	-
SGO 12x4	-	10.01.05.00428	10.01.05.00235	-	-
SGO 15x5	-	10.01.05.00429	-	10.01.05.00071	-
SGO 18x6	-	10.01.05.00430	-	10.01.05.00072	-
SGO 24x8	-	10.01.05.00437	-	10.01.05.00151	-
SGO 30x10	10.01.05.00848	10.01.05.00438	-	10.01.05.00152	-
SGO 45x15	-	10.01.05.00439	-	10.01.05.00153	-
SGO 60x20	-	10.01.05.00440	-	10.01.05.00154	-
SGO 75x25	-	10.01.05.00441	-	10.01.05.00155	-
SGO 90x30	-	-	-	-	10.01.05.00156

\*Additional material specifications at beginning of the section "Vacuum Suction Cups"

Type	Suction cup material with ShA: *				
	NBR-AS-55	NBR-AS-60	SI-60	SI-65	SI-70
SGO 4x2	-	-	10.01.01.00463	-	-
SGO 7x3.5	-	10.01.05.00224	10.01.01.00464	-	-
SGO 12x4	10.01.05.00237	-	-	10.01.01.00222	-
SGO 15x5	-	10.01.05.00225	10.01.05.00079	-	-
SGO 18x6	-	10.01.05.00226	10.01.05.00080	-	-
SGO 24x8	-	10.01.05.00227	10.01.05.00157	-	-
SGO 30x10	-	-	10.01.05.00158	-	-
SGO 45x15	-	-	10.01.05.00159	-	-
SGO 60x20	-	-	10.01.05.00160	-	-
SGO 75x25	-	-	10.01.05.00161	-	-
SGO 90x30	-	-	-	-	10.01.05.00162

\*Additional material specifications at beginning of the section "Vacuum Suction Cups"



# Flat Suction Cups SGON

Suction area (LxW) from 4 x 2 mm to 90 x 30 mm



## Ordering Data Spare Parts Flat Suction Cups SGON

Type	Spare Parts		Part no.
SGON 4x2	M3-AG	Suction cup connection nipple	SA-NIP N003 M3-AG DN100 10.01.01.00316
SGON 7x3.5	M3-AG	Suction cup connection nipple	SA-NIP N003 M3-AG DN100 10.01.01.00316
SGON 12x4	M5-AG	Suction cup connection nipple	SA-NIP N020 M5-AG DN180 10.01.01.00312
SGON 15x5	M5-AG	Suction cup connection nipple	SA-NIP N021 M5-AG DN200 10.01.05.00126
SGON 15x5	M5-IG	Suction cup connection nipple	SA-NIP N021 M5-IG DN200 10.01.05.00125
SGON 18x6	M5-AG	Suction cup connection nipple	SA-NIP N021 M5-AG DN200 10.01.05.00126
SGON 18x6	M5-IG	Suction cup connection nipple	SA-NIP N021 M5-IG DN200 10.01.05.00125
SGON 24x8	G1/8-AG	Suction cup connection nipple	SA-NIP N022 G1/8-AG DN350 10.01.05.00124
SGON 24x8	G1/8-IG	Suction cup connection nipple	SA-NIP N022 G1/8-IG DN350 10.01.05.00123
SGON 30x10	G1/8-AG	Suction cup connection nipple	SA-NIP N022 G1/8-AG DN350 10.01.05.00124
SGON 30x10	G1/8-IG	Suction cup connection nipple	SA-NIP N022 G1/8-IG DN350 10.01.05.00123
SGON 45x15	G1/4-AG	Suction cup connection nipple	SA-NIP N023 G1/4-AG DN350 10.01.05.00122
SGON 45x15	G1/4-IG	Suction cup connection nipple	SA-NIP N023 G1/4-IG DN350 10.01.05.00121
SGON 60x20	G1/4-AG	Suction cup connection nipple	SA-NIP N023 G1/4-AG DN350 10.01.05.00122
SGON 60x20	G1/4-IG	Suction cup connection nipple	SA-NIP N023 G1/4-IG DN350 10.01.05.00121
SGON 75x25	G1/4-AG	Suction cup connection nipple	SA-NIP N023 G1/4-AG DN350 10.01.05.00122
SGON 75x25	G1/4-IG	Suction cup connection nipple	SA-NIP N023 G1/4-IG DN350 10.01.05.00121
SGON 90x30	G1/4-AG	Suction cup connection nipple	SA-NIP N023 G1/4-AG DN350 10.01.05.00122
SGON 90x30	G1/4-IG	Suction cup connection nipple	SA-NIP N023 G1/4-IG DN350 10.01.05.00121

Type	Spare Parts		Part no.
SGON 24x8	Two-ear clamp	ZOKL 11-13	10.07.10.00032
SGON 30x10	Two-ear clamp	ZOKL 11-13	10.07.10.00032
SGON 45x15	Two-ear clamp	ZOKL 15-18	10.07.10.00033
SGON 60x20	Two-ear clamp	ZOKL 15-18	10.07.10.00033
SGON 75x25	Two-ear clamp	ZOKL 15-18	10.07.10.00033
SGON 90x30	Two-ear clamp	ZOKL 15-18	10.07.10.00033



## Technical Data Flat Suction Cups SGON

Type	Suction force [N]*	Volume [cm³]	Workpiece radius min. (convex) [mm]	Hose diameter (recom.) d [mm]**	Nipple family
SGON 4x2	0.42	0.018	1	2	N 003
SGON 7x3.5	1.00	0.029	3	2	N 003
SGON 12x4	1.80	0.173	3	2	N 020
SGON 15x5	3.10	0.175	4	2	N 021
SGON 18x6	4.50	0.205	4	2	N 021
SGON 24x8	8.00	0.327	8	4	N 022
SGON 30x10	12.20	0.516	8	4	N 022
SGON 45x15	28.20	2.306	10	6	N 023
SGON 60x20	50.10	3.611	20	6	N 023
SGON 75x25	78.30	5.860	30	6	N 023
SGON 90x30	112.60	9.473	35	6	N 023

\*The specified suction forces are theoretical values at a vacuum of -0.6 bar and with a smooth, dry workpiece surface - they do not include a safety factor

\*\*The recommended hose diameter refers to a hose length of approx. 2 m



# Flat Suction Cups SGON

Suction area (LxW) from 4 x 2 mm to 90 x 30 mm

Vacuum Suction Cups

Special Grippers

Gripping Systems

Clamping Systems

Mounting Elements

Vacuum Generators

Valve Technology

Switches and Monitoring

Filters and Connections

Services

Contact

Glossary

Index of Products



## Design Data Flat Suction Cups SGON

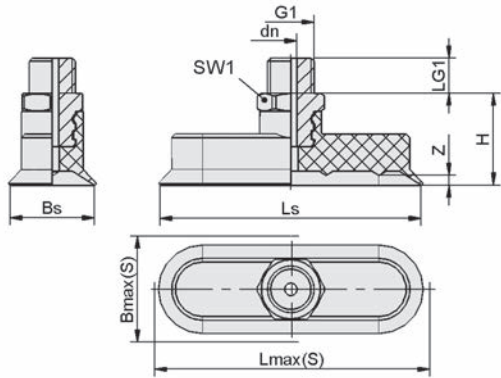

SGON 4x2 - 90x30 AG

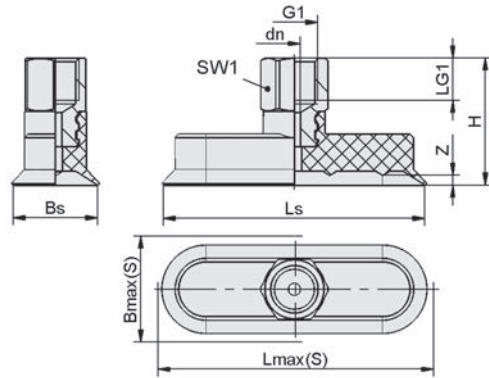

SGON 15x5 - 90x30 IG

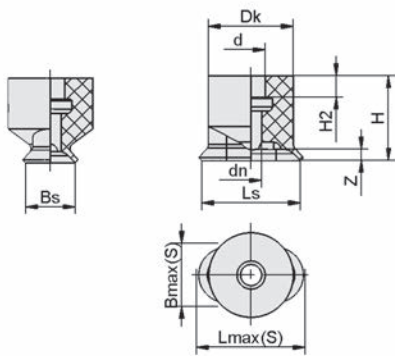

SGO 4x2, 7x3.5

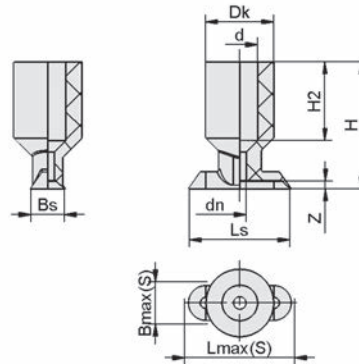

SGO 12x4

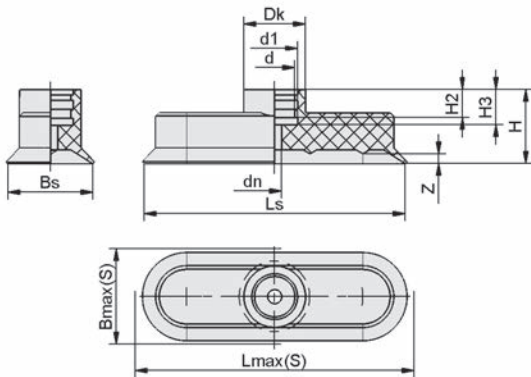

SGO 15x5 - 90x30



# Flat Suction Cups SGON

Suction area (LxW) from 4 x 2 mm to 90 x 30 mm



## Design Data Flat Suction Cups SGON

Type*	Bmax(S) [mm]**	Bs [mm]	dn [mm]	G1	H [mm]	LG1 [mm]	Lmax(S) [mm]***	Ls [mm]	SW1 [mm]	Z (Stroke) [mm]	
SGON 4x2	M3-AG	2.5	2.0	1.0	M3-M	8	3.0	4.5	4.0	5	0.5
SGON 7x3.5	M3-AG	4.5	3.5	1.0	M3-M	8	3.0	7.5	7.0	5	0.8
SGON 12x4	M5-AG	5.0	3.9	1.5	M5-M	18	4.5	13.0	11.9	8	0.5
SGON 15x5	M5-AG	5.5	5.0	1.2	M5-M	17	5.0	15.5	15.0	8	0.7
SGON 15x5	M5-IG	5.5	5.0	1.2	M5-F	22	5.5	15.5	15.0	8	0.7
SGON 18x6	M5-AG	7.0	6.0	1.5	M5-M	17	5.0	18.5	18.0	8	0.8
SGON 18x6	M5-IG	7.0	6.0	1.5	M5-F	22	5.5	18.5	18.0	8	0.8
SGON 24x8	G1/8-AG	9.0	8.0	1.5	G1/8"-M	17	8.0	24.5	24.0	14	1.0
SGON 24x8	G1/8-IG	9.0	8.0	1.5	G1/8"-F	25	9.0	24.5	24.0	14	1.0
SGON 30x10	G1/8-AG	11.5	9.4	2.5	G1/8"-M	17	8.0	30.5	29.4	14	1.5
SGON 30x10	G1/8-IG	11.5	9.4	2.5	G1/8"-F	25	9.0	30.5	29.4	14	1.5
SGON 45x15	G1/4-AG	16.5	14.4	3.0	G1/4"-M	26	10.0	46.0	44.4	17	2.0
SGON 45x15	G1/4-IG	16.5	14.4	3.0	G1/4"-F	36	12.0	46.0	44.4	17	2.0
SGON 60x20	G1/4-AG	22.0	19.0	3.5	G1/4"-M	26	10.0	61.0	59.0	17	2.5
SGON 60x20	G1/4-IG	22.0	20.0	3.5	G1/4"-F	36	12.0	61.0	60.0	17	2.5
SGON 75x25	G1/4-AG	27.5	25.0	3.5	G1/4"-M	26	10.0	77.0	75.0	17	2.8
SGON 75x25	G1/4-IG	27.5	25.0	3.5	G1/4"-F	36	12.0	77.0	75.0	17	2.8
SGON 90x30	G1/4-AG	33.0	30.0	3.5	G1/4"-M	26	10.0	92.5	90.0	17	3.5
SGON 90x30	G1/4-IG	33.0	30.0	3.5	G1/4"-F	36	12.0	92.5	90.0	17	3.5

\*Acceptable dimensional tolerances for rubber parts concerning to DIN ISO 3302-1 M3

\*\*External dimension of the suction cup when it is pressed against the workpiece by the vacuum

\*\*\*External dimension of the suction cup when it is pressed against the workpiece by the vacuum

Type*	Bmax(S) [mm]**	Bs [mm]	d [mm]	dn [mm]	Dk [mm]	d1 [mm]	H [mm]	H2 [mm]	H3 [mm]	Lmax(S) [mm]***	Ls [mm]	Z (Stroke) [mm]
SGO 4x2	2.5	2.2	1.2	1.2	2.2	-	3.0	1.5	-	4.5	4.2	0.5
SGO 7x3.5	4.5	3.5	1.5	1.5	6.0	-	6.0	1.5	-	7.5	7.0	0.8
SGO 12x4	5.0	4.0	4.2	1.5	8.0	-	15.0	9.3	-	13.0	12.0	0.5
SGO 15x5	5.5	4.6	4.5	1.2	8.5	6	12.0	3.0	5.5	15.5	14.6	0.7
SGO 18x6	7.0	5.6	4.5	1.5	8.5	6	12.0	3.0	5.5	18.5	17.6	0.8
SGO 24x8	9.0	7.6	5.5	1.5	11.5	7	12.0	3.0	5.5	24.5	23.6	1.0
SGO 30x10	11.5	9.4	5.5	2.5	11.5	7	12.0	3.0	5.5	30.5	29.4	1.5
SGO 45x15	16.5	14.4	11.5	3.0	15.5	13	21.0	8.0	10.0	46.0	44.4	2.0
SGO 60x20	22.0	19.0	11.5	4.0	15.5	13	21.0	8.0	10.0	61.0	59.0	2.5
SGO 75x25	27.5	24.0	11.5	4.0	17.5	13	21.0	8.0	10.0	77.0	74.0	2.8
SGO 90x30	33.0	29.0	11.5	4.0	17.5	13	21.0	8.0	10.0	92.5	89.0	3.5

\*Acceptable dimensional tolerances for rubber parts concerning to DIN ISO 3302-1 M3

\*\*External dimension of the suction cup when it is pressed against the workpiece by the vacuum

\*\*\*External dimension of the suction cup when it is pressed against the workpiece by the vacuum

# Suction Plates SPLO



Suction area (LxW) from 60 x 20 mm to 370 x 80 mm



## Suitability for Industry Specific Applications

### Applications

- Oval suction plate for handling of long, narrow workpieces such as sections or door and window frames
- Considerably higher suction force than round, flat suction cups with long, narrow workpieces
- SPLO 100x32-TV and SPLO 300x100-TV available with touch valve to detect presence of workpieces
- SPLO 100x30 to SPLO 300x100 with long sealing lip for handling very curved workpieces



Suction Plates SPLO

### Design

- Robust and wear-resistant suction plate with single sealing lip
- Sealing lip vulcanized to support plate
- SPLO 100x32-TV and SPLO 300x100-TV with touch valve
- Sealing lip made of NBR for minimum marking of workpieces



System Design Suction Plates SPLO

### Our Highlights...

- Oval, flat suction plate
- Support plate made of steel/ aluminum with sealing lip vulcanized to it
- Sealing lip made of NBR
- Various sizes and shapes

### Your Benefits...

- Handling of long, narrow workpieces, also curved workpieces (such as sections)
- Capable of handling heavy loads; flexible mounting facilities
- Little marking, even of sensitive surfaces
- Wide range of cups for many different workpieces

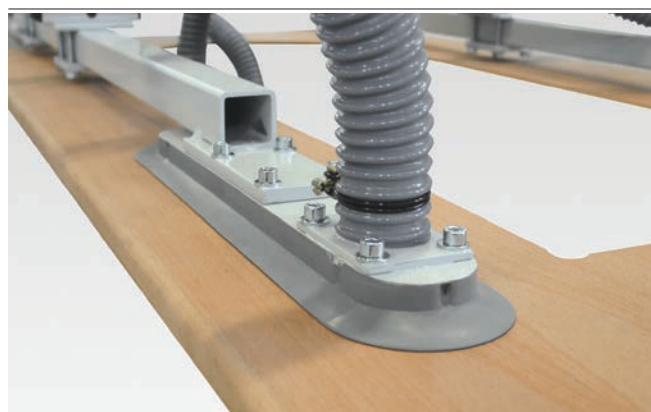

Suction plates SPLO being used for handling wooden doors

- Schmalz – The Company
- Vacuum Suction Cups
- Special Grippers
- Gripping Systems
- Clamping Systems
- Mounting Elements
- Vacuum Generators
- Valve Technology
- Switches and Monitoring
- Filters and Connections
- Services
- Contact
- Glossary
- Index of Products

# Suction Plates SPLO

Suction area (LxW) from 60 x 20 mm to 370 x 80 mm



## Designation Code Suction Plates SPLO

SPLO	-	60x20	-	NBR-55	-	G1/8-IG	-	
1		2		3		4		5

### 1 – Abbreviated designation

Code	Version
SPLO	Flat, oval

### 2 – Suction area

Code	LxW in mm
60x20...370x80	60x20 to 370x80

### 3 – Material

Code	Material
NBR-55	Nitrile caoutchuc

### 4 – Connection

Code	Connection
G1/8-IG	G1/8-IG (IG = female (F))
G1/4-IG	G1/4-IG

### 5 – Product addition

Code	Type
TV	Touch valve

Suction plate SPLO, available in various diameters and optionally with touch valve, is delivered with support plate vulcanized to elastomer part.



## Ordering Data Suction Plates SPLO

Type*	Part no.
SPLO 60x20 NBR-55 G1/8-IG	10.01.05.00001
SPLO 100x30 NBR-55	10.01.05.00182
SPLO 100x32 NBR-55 G1/4-IG	10.01.05.00002
SPLO 100x32 NBR-55 TV	10.01.05.00003
SPLO 150x55 NBR-55	10.01.05.00046
SPLO 200x30 NBR-55	10.01.05.00183
SPLO 200x55 NBR-55	10.01.05.00004
SPLO 250x55 NBR-55	10.01.05.00186
SPLO 300x30 NBR-55	10.01.05.00184
SPLO 300x55 NBR-55	10.01.05.00187
SPLO 300x100 NBR-55	10.01.05.00050
SPLO 300x100 NBR-55 TV	10.01.05.00188
SPLO 370x80 NBR-55	10.01.05.00006

\*Additional material specifications at beginning of the section "Vacuum Suction Cups"



## Technical Data Suction Plates SPLO

Type	Suction force [N]*	Volume [cm <sup>3</sup> ]	Workpiece radius min. (convex) [mm]
SPLO 60x20 NBR-55 G1/8-IG	50	3	15
SPLO 100x30 NBR-55	126	10	25
SPLO 100x32 NBR-55 G1/4-IG	134	11	50
SPLO 100x32 NBR-55 TV	134	11	50
SPLO 150x55 NBR-55	340	60	75
SPLO 200x30 NBR-55	260	24	30
SPLO 200x55 NBR-55	465	80	50
SPLO 250x55 NBR-55	590	83	50
SPLO 300x30 NBR-55	400	32	30
SPLO 300x55 NBR-55	710	93	50
SPLO 300x100 NBR-55	1,250	256	175
SPLO 300x100 NBR-55 TV	1,250	256	175
SPLO 370x80 NBR-55	1,270	194	100

\*The specified suction forces are theoretical values at a vacuum of -0.6 bar and with a smooth, dry workpiece surface - they do not include a safety factor



Schmalz – The Company  
Vacuum Suction Cups  
Special Grippers  
Gripping Systems  
Clamping Systems  
Mounting Elements  
Vacuum Generators  
Valve Technology  
Switches and Monitoring  
Filters and Connections  
Services  
Contact  
Glossary  
Index of Products

# Suction Plates SPLO

Suction area (LxW) from 60 x 20 mm to 370 x 80 mm



## Design Data Suction Plates SPLO

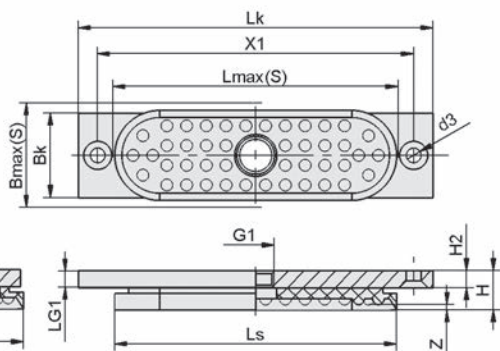

SPLO 60x20, 100x32

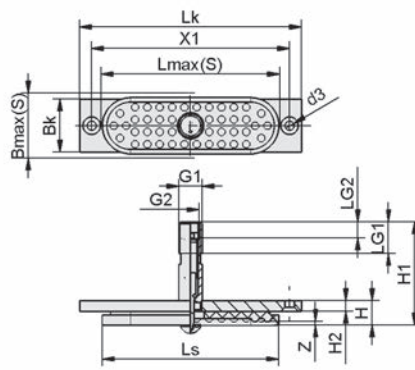

SPLO 100x32 TV

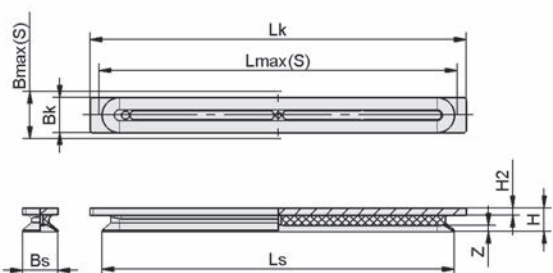

SPLO 100x30, 200x30, 300x30

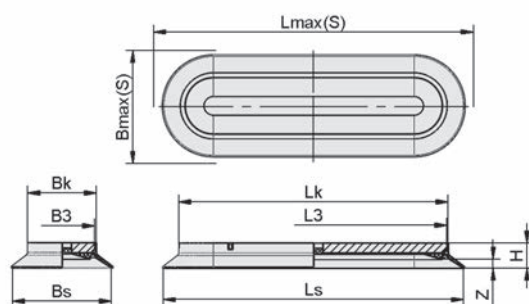

SPLO 150x55, 200x55, 250x55, 300x55

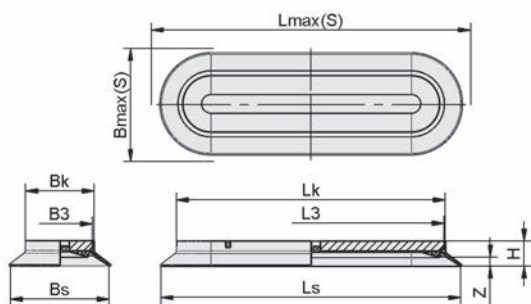

SPLO 300x100

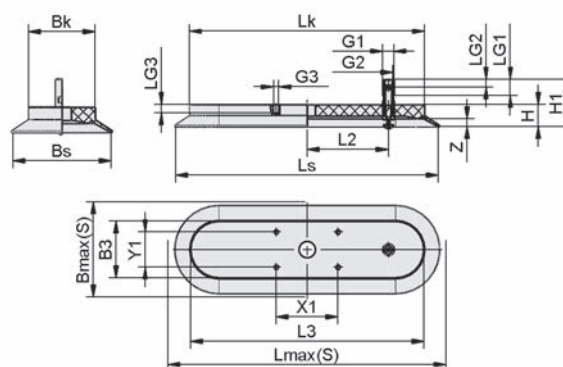

SPLO 300x100 TV





# Suction Plates SPLO

Suction area (LxW) from 60 x 20 mm to 370 x 80 mm



## Design Data Suction Plates SPLO

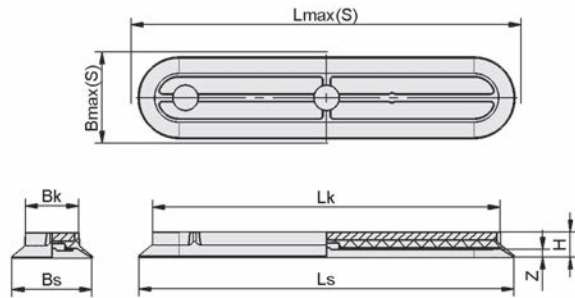

SPLO 370x80

Type*	Bk [mm]	Bmax(S) [mm]**	Bs [mm]	B3 [mm]	d3 [mm]	G1	G2	G3	H [mm]	H1 [mm]	H2 [mm]
SPLO 60x20 NBR-55 G1/8-IG	20	21.0	19.0	-	4.5	G1/8"-F	-	-	12.6	-	6
SPLO 100x30 NBR-55	30	33.5	28.7	-	-	-	-	-	21.0	-	6
SPLO 100x32 NBR-55 G1/4-IG	30	34.0	32.0	-	5.3	G1/4"-F	-	-	14.0	-	6
SPLO 100x32 NBR-55 TV	30	34.0	32.0	-	5.3	G1/4"-M	G1/8"-F	-	14.0	54.0	6
SPLO 150x55 NBR-55	32	61.0	52.3	29	-	-	-	-	19.4	-	-
SPLO 200x30 NBR-55	30	32.0	29.2	-	-	-	-	-	20.6	-	6
SPLO 200x55 NBR-55	31	62.0	50.7	26	-	-	-	-	22.0	-	-
SPLO 250x55 NBR-55	32	58.0	47.6	29	-	-	-	-	22.0	-	-
SPLO 300x30 NBR-55	30	33.0	30.0	-	-	-	-	-	20.0	-	6
SPLO 300x55 NBR-55	31	60.0	51.4	28	-	-	-	-	19.0	-	-
SPLO 300x100 NBR-55	68	108.0	98.8	65	-	-	-	-	25.0	-	-
SPLO 300x100 NBR-55 TV	68	108.0	98.8	65	-	G1/4"-M	G1/8"-F	M6-F	25.0	53.5	-
SPLO 370x80 NBR-55	53	86.0	79.4	45	-	-	-	-	25.0	-	-

\*Acceptable dimensional tolerances for rubber parts concerning to DIN ISO 3302-1 M3

\*\*External dimension of the suction cup when it is pressed against the workpiece by the vacuum

Type*	LG1 [mm]	LG2 [mm]	LG3 [mm]	Lk [mm]	Lmax(S) [mm]**	Ls [mm]	L2 [mm]	L3 [mm]	X1 [mm]	Y1 [mm]	Z (Stroke) [mm]
SPLO 60x20 NBR-55 G1/8-IG	6	-	-	75.0	61.0	59.0	-	-	65	-	3
SPLO 100x30 NBR-55	-	-	-	120.0	120.0	98.0	-	-	-	-	5
SPLO 100x32 NBR-55 G1/4-IG	6	-	-	125.8	125.8	100.0	-	-	112	-	2
SPLO 100x32 NBR-55 TV	18	9	-	125.8	125.8	100.0	-	-	112	-	2
SPLO 150x55 NBR-55	-	-	-	126.5	157.0	147.3	-	124.0	-	-	7
SPLO 200x30 NBR-55	-	-	-	220.0	203.0	200.0	-	-	-	-	6
SPLO 200x55 NBR-55	-	-	-	178.0	208.0	197.7	-	171.0	-	-	9
SPLO 250x55 NBR-55	-	-	-	226.0	255.0	243.0	-	224.5	-	-	8
SPLO 300x30 NBR-55	-	-	-	320.0	304.0	300.0	-	-	-	-	5
SPLO 300x55 NBR-55	-	-	-	275.3	305.0	296.4	-	273.0	-	-	7
SPLO 300x100 NBR-55	-	-	-	266.7	308.0	297.8	-	264.0	-	-	9
SPLO 300x100 NBR-55 TV	13	10	9	266.7	308.0	297.8	92	264.0	70	40	9
SPLO 370x80 NBR-55	-	-	-	344.9	376.0	372.4	-	338.0	-	-	8

\*Acceptable dimensional tolerances for rubber parts concerning to DIN ISO 3302-1 M3

\*\*External dimension of the suction cup when it is pressed against the workpiece by the vacuum



# Bellows Suction Cups FSGA (1.5 Folds)

Suction area (Ø) from 4 mm to 78 mm



## Suitability for Industry Specific Applications

### Applications

- Round, bellows suction cup with 1.5 folds for handling of extremely sensitive workpieces (optimum damping effect due to folds and smooth sealing lip)
- Handling of workpieces with uneven surfaces, such as pipes (folds permit optimal adaptation to concave and convex surfaces)



Bellows Suction Cups FSGA (1.5 Folds)

### Design

- Robust, wear-resistant suction cup FSGA (3) with single sealing lip, consisting of suction cup FGA (2) with 1.5 folds and connection nipple (1)
- All nipples are plugged in
- Suction cups with a diameter of 25 mm or more with supports on the bottom
- With each nipple family, the replacement cups and nipples can be combined as desired

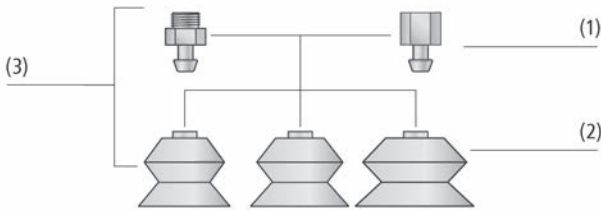

System Design Bellows Suction Cups FSGA (1.5 Folds)



Bellows suction cups FSGA being used for handling cardboard boxes

### Our Highlights...

- Wide range of diameters and materials
- Soft, tapered sealing lip
- 1.5 folds; supports on the bottom (diameter > 25 mm)
- Very stiff top fold

### Your Benefits...

- For a wide range of different workpieces
- Very good adaptation to curved or uneven workpiece surfaces
- High suction force and optimum damping effect during placement on workpieces
- Good resistance to horizontal forces at high acceleration values

- Schmalz – The Company
- Vacuum Suction Cups
- Special Grippers
- Gripping Systems
- Clamping Systems
- Mounting Elements
- Vacuum Generators
- Valve Technology
- Switches and Monitoring
- Filters and Connections
- Services
- Contact
- Glossary
- Index of Products



# Bellows Suction Cups FSGA (1.5 Folds)

Suction area (Ø) from 4 mm to 78 mm



## Designation Code Bellows Suction Cups FSGA (1.5 Folds)

<b>FSGA</b>	-	<b>14</b>	-	<b>HT1-60</b>	-	<b>G1/8-IG</b>
1		2		3		4

### 1 - Abbreviated designation

Code	Version
FSGA	1.5 folds

### 2 - Suction area

Code	Diameter in mm
4...78	ø 4 to 78

### 3 - Material

Code	Material
HT1-60	High temperature material
NBR-55	Nitrile caoutchuc
NK-45	Natural rubber
SI-55	Silicone
SI-HD	Silicone
SI-MD	Silicone

### 4 - Connection

Code	Connection
M3-AG	M3-AG (AG = male (M))
M5-AG	M5-AG
M5-IG	M5-IG (IG = female (F))
G1/8-AG	G1/8-AG
G1/8-IG	G1/8-IG
G1/4-AG	G1/4-AG
G1/4-IG	G1/4-IG

Suction cup FSGA (elastomer part + connection nipple) is delivered unassembled (diameters of 33 mm and more are assembled). The delivery consists of:

- Suction cup of type FGA – elastomer part, available in various diameters and materials
- Connection nipple of type SA-NIP – available with various threads

Available spare parts: suction cup FGA, connection nipple SA-NIP



## Ordering Data Bellows Suction Cups FSGA (1.5 Folds)

Type			Suction cup material with ShA: *					
			HT1-60	NBR-55	NK-45	SI-55	SI-HD	SI-MD-55
FSGA	4	M3-AG	10.01.06.04145	10.01.06.04143	-	10.01.06.04144	-	-
FSGA	6	M5-AG	10.01.06.02996	10.01.06.02994	-	10.01.06.02995	10.01.06.04175	-
FSGA	6	M5-IG	10.01.06.03000	10.01.06.02998	-	10.01.06.02999	10.01.06.04174	-
FSGA	11	M5-AG	10.01.06.01227	10.01.06.00076	10.01.06.00406	10.01.06.00086	10.01.06.04176	10.01.06.04193
FSGA	11	G1/8-AG	10.01.06.01226	10.01.06.00075	10.01.06.00408	10.01.06.00085	10.01.06.04177	10.01.06.04194
FSGA	11	G1/8-IG	10.01.06.01232	10.01.06.00061	10.01.06.00407	10.01.06.00068	10.01.06.04178	10.01.06.04195
FSGA	14	M5-AG	10.01.06.00933	10.01.06.00379	10.01.06.00385	10.01.06.00382	10.01.06.04179	10.01.06.04196
FSGA	14	G1/8-AG	10.01.06.00932	10.01.06.00381	10.01.06.00387	10.01.06.00384	10.01.06.04180	10.01.06.04197
FSGA	14	G1/8-IG	10.01.06.00948	10.01.06.00380	10.01.06.00386	10.01.06.00383	10.01.06.04181	10.01.06.04198
FSGA	16	M5-AG	10.01.06.01229	10.01.06.00078	10.01.06.00409	10.01.06.00088	10.01.06.04182	10.01.06.04199
FSGA	16	G1/8-AG	10.01.06.01228	10.01.06.00077	10.01.06.00411	10.01.06.00087	10.01.06.04183	10.01.06.04200
FSGA	16	G1/8-IG	10.01.06.01233	10.01.06.00062	10.01.06.00410	10.01.06.00069	10.01.06.04184	10.01.06.04201
FSGA	20	M5-AG	10.01.06.00937	10.01.06.00388	10.01.06.00394	10.01.06.00391	10.01.06.04185	10.01.06.04202
FSGA	20	G1/8-AG	10.01.06.00936	10.01.06.00390	10.01.06.00396	10.01.06.00393	10.01.06.04186	10.01.06.04203
FSGA	20	G1/8-IG	10.01.06.00952	10.01.06.00389	10.01.06.00395	10.01.06.00392	10.01.06.04187	10.01.06.04204
FSGA	22	M5-AG	10.01.06.01231	10.01.06.00080	10.01.06.00412	10.01.06.00090	10.01.06.04188	10.01.06.04205
FSGA	22	G1/8-AG	10.01.06.01230	10.01.06.00079	10.01.06.00414	10.01.06.00089	10.01.06.04189	10.01.06.04206
FSGA	22	G1/8-IG	10.01.06.01234	10.01.06.00063	10.01.06.00413	10.01.06.00070	10.01.06.04190	10.01.06.04207
FSGA	25	G1/8-AG	10.01.06.00940	10.01.06.00399	10.01.06.00405	10.01.06.00402	10.01.06.04191	10.01.06.04208
FSGA	25	G1/8-IG	10.01.06.00956	10.01.06.00398	10.01.06.00404	10.01.06.00401	10.01.06.04192	10.01.06.04209
FSGA	33	G1/4-AG	10.01.06.00941	10.01.06.00081	10.01.06.00330	10.01.06.00091	-	10.01.06.04210
FSGA	33	G1/4-IG	10.01.06.00957	10.01.06.00064	10.01.06.00415	10.01.06.00071	-	10.01.06.04211



Schmalz – The Company  
Vacuum Suction Cups  
Special Grippers  
Gripping Systems  
Clamping Systems  
Mounting Elements  
Vacuum Generators  
Valve Technology  
Switches and Monitoring  
Filters and Connections  
Services  
Contact  
Glossary  
Index of Products

# Bellows Suction Cups FSGA (1.5 Folds)

Suction area (Ø) from 4 mm to 78 mm



## Ordering Data Bellows Suction Cups FSGA (1.5 Folds)

Type			Suction cup material with ShA: *					
			HT1-60	NBR-55	NK-45	SI-55	SI-HD	SI-MD-55
FSGA	43	G1/4-AG	10.01.06.00942	10.01.06.00082	10.01.06.00418	10.01.06.00092	-	-
FSGA	43	G1/4-IG	10.01.06.00958	10.01.06.00065	10.01.06.00417	10.01.06.00072	-	-
FSGA	53	G1/4-AG	10.01.06.00943	10.01.06.00083	10.01.06.00326	10.01.06.00093	-	-
FSGA	53	G1/4-IG	10.01.06.00977	10.01.06.00066	10.01.06.00419	10.01.06.00073	-	-
FSGA	63	G1/4-AG	10.01.06.02476	10.01.06.00685	10.01.06.00687	10.01.06.00686	-	-
FSGA	63	G1/4-IG	10.01.06.02477	10.01.06.00691	10.01.06.00693	10.01.06.00692	-	-
FSGA	78	G1/4-AG	10.01.06.02478	10.01.06.00084	10.01.06.00340	10.01.06.00094	-	-
FSGA	78	G1/4-IG	10.01.06.02479	10.01.06.00067	10.01.06.00421	10.01.06.00074	-	-

\*Additional material specifications at beginning of the section "Vacuum Suction Cups"



## Ordering Data Spare Parts Bellows Suction Cups FSGA (1.5 Folds)

Type			Suction cup material with ShA: *					
			HT1-60	NBR-55	NK-45	SI-55	SI-HD	SI-MD-55
FGA	4		10.01.06.04093	10.01.06.04066	-	10.01.06.04092	-	-
FGA	6		10.01.06.02603	10.01.06.02981	10.01.06.02604	10.01.06.01571	10.01.06.03442	-
FGA	11		10.01.06.01247	10.01.06.00095	10.01.06.00423	10.01.06.00098	10.01.06.03986	10.01.06.04151
FGA	14		10.01.06.00868	10.01.06.00370	10.01.06.00372	10.01.06.00371	10.01.06.03143	10.01.06.04114
FGA	16		10.01.06.01248	10.01.06.00096	10.01.06.00424	10.01.06.00099	10.01.06.02459	10.01.06.04115
FGA	20		10.01.06.00870	10.01.06.00373	-	10.01.06.00374	10.01.06.04150	10.01.06.03892
FGA	22		10.01.06.01249	10.01.06.00097	10.01.06.00425	10.01.06.00100	10.01.06.03419	10.01.06.04152
FGA	25		10.01.06.00872	10.01.06.00376	10.01.06.00378	10.01.06.00377	10.01.06.03245	10.01.06.04153
FGA	33		10.01.06.00873	10.01.06.00130	10.01.06.00426	10.01.06.00126	-	10.01.06.04096
FGA	43		10.01.06.00874	10.01.06.00131	10.01.06.00427	10.01.06.00127	-	-
FGA	53		10.01.06.00875	10.01.06.00132	10.01.06.00428	10.01.06.00128	-	-
FGA	63		10.01.06.02473	10.01.06.00688	10.01.06.00690	10.01.06.00689	-	-
FGA	78		10.01.06.02474	10.01.06.00133	10.01.06.00429	10.01.06.00129	-	-

\*Additional material specifications at beginning of the section "Vacuum Suction Cups"

Type	Spare Parts		Part no.	
FSGA 4	M3-AG	Suction cup connection nipple	SA-NIP N003 M3-AG DN100	10.01.01.00316
FSGA 6	M5-AG	Suction cup connection nipple	SA-NIP N004 M5-AG DN200	10.01.01.03526
FSGA 11	M5-AG	Suction cup connection nipple	SA-NIP N016 M5-AG DN250	10.01.06.00123
FSGA 11	G1/8-AG	Suction cup connection nipple	SA-NIP N016 G1/8-AG DN350	10.01.06.05735
FSGA 14	M5-AG	Suction cup connection nipple	SA-NIP N016 M5-AG DN250	10.01.06.00123
FSGA 14	G1/8-AG	Suction cup connection nipple	SA-NIP N016 G1/8-AG DN350	10.01.06.05735
FSGA 16	M5-AG	Suction cup connection nipple	SA-NIP N016 M5-AG DN250	10.01.06.00123
FSGA 16	G1/8-AG	Suction cup connection nipple	SA-NIP N016 G1/8-AG DN350	10.01.06.05735
FSGA 20	M5-AG	Suction cup connection nipple	SA-NIP N016 M5-AG DN250	10.01.06.00123
FSGA 20	G1/8-AG	Suction cup connection nipple	SA-NIP N016 G1/8-AG DN350	10.01.06.05735
FSGA 22	M5-AG	Suction cup connection nipple	SA-NIP N016 M5-AG DN250	10.01.06.00123
FSGA 22	G1/8-AG	Suction cup connection nipple	SA-NIP N016 G1/8-AG DN350	10.01.06.05735
FSGA 25	G1/8-AG	Suction cup connection nipple	SA-NIP N016 G1/8-AG DN350	10.01.06.05735
FSGA 33	G1/4-AG	Suction cup connection nipple	SA-NIP N018 G1/4-AG DN440	10.01.06.01065
FSGA 43	G1/4-AG	Suction cup connection nipple	SA-NIP N018 G1/4-AG DN440	10.01.06.01065
FSGA 53	G1/4-AG	Suction cup connection nipple	SA-NIP N018 G1/4-AG DN440	10.01.06.01065
FSGA 63	G1/4-AG	Suction cup connection nipple	SA-NIP N018 G1/4-AG DN440	10.01.06.01065
FSGA 78	G1/4-AG	Suction cup connection nipple	SA-NIP N019 G1/4-AG DN820	10.01.06.01959



# Bellows Suction Cups FSGA (1.5 Folds)

Suction area (Ø) from 4 mm to 78 mm



## Ordering Data Spare Parts Bellows Suction Cups FSGA (1.5 Folds)

Type	Spare Parts			Part no.
FSGA 6	M5-IG	Suction cup connection nipple	SA-NIP N004 M5-IG DN200	10.01.01.03518
FSGA 11	G1/8-IG	Suction cup connection nipple	SA-NIP N016 G1/8-IG DN350	10.01.06.05731
FSGA 14	G1/8-IG	Suction cup connection nipple	SA-NIP N016 G1/8-IG DN350	10.01.06.05731
FSGA 16	G1/8-IG	Suction cup connection nipple	SA-NIP N016 G1/8-IG DN350	10.01.06.05731
FSGA 20	G1/8-IG	Suction cup connection nipple	SA-NIP N016 G1/8-IG DN350	10.01.06.05731
FSGA 22	G1/8-IG	Suction cup connection nipple	SA-NIP N016 G1/8-IG DN350	10.01.06.05731
FSGA 25	G1/8-IG	Suction cup connection nipple	SA-NIP N016 G1/8-IG DN350	10.01.06.05731
FSGA 33	G1/4-IG	Suction cup connection nipple	SA-NIP N018 G1/4-IG DN440	10.01.06.01066
FSGA 43	G1/4-IG	Suction cup connection nipple	SA-NIP N018 G1/4-IG DN440	10.01.06.01066
FSGA 53	G1/4-IG	Suction cup connection nipple	SA-NIP N018 G1/4-IG DN440	10.01.06.01066
FSGA 78	G1/4-IG	Suction cup connection nipple	SA-NIP N019 G1/4-IG DN820	10.01.06.01960



## Technical Data Bellows Suction Cups FSGA (1.5 Folds)

Type	Suction force [N]*	Pull-off force [N]**	Volume [cm <sup>3</sup> ]	Workpiece radius min. (convex) [mm]	Hose diameter (recom.) d [mm]***	Nipple family
FSGA 4	0.29	0.5	0.035	2	3	N 003
FSGA 6	0.40	1.4	0.098	4	4	N 004
FSGA 11	0.95	3.8	0.225	10	4	N 016
FSGA 14	1.20	5.0	0.420	15	4	N 016
FSGA 16	2.30	6.7	0.750	20	4	N 016
FSGA 20	4.70	10.7	1.150	20	4	N 016
FSGA 22	5.70	15.2	1.400	25	4	N 016
FSGA 25	5.30	17.3	2.944	25	4	N 016
FSGA 33	13.60	39.6	4.750	40	6	N 018
FSGA 43	22.80	64.5	9.250	60	6	N 018
FSGA 53	51.30	95.0	26.488	100	6	N 018
FSGA 63	85.00	135.0	43.829	100	6	N 018
FSGA 78	137.40	218.0	75.583	100	6	N 019

\*The suction force figures are theoretical values at a vacuum of -0.6 bar and with a smooth, flat workpiece surface. They are specified without any safety factor. For the system design the safety factors should be increased at least by the factor 3.

\*\*The pull-off force of the versions made of natural rubber is reduced by about 40 %

\*\*\*The recommended hose diameter refers to a hose length of approx. 2 m

# Bellows Suction Cups FSGA (1.5 Folds)

Suction area ( $\varnothing$ ) from 4 mm to 78 mm

**Design Data Bellows Suction Cups FSGA (1.5 Folds)**

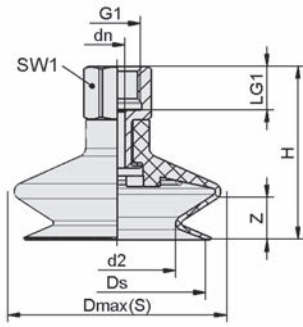

FSGA IG

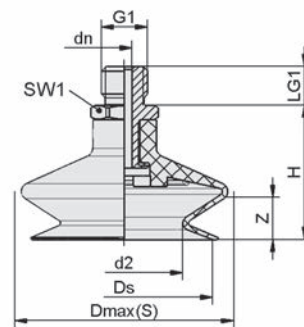

FSGA AG

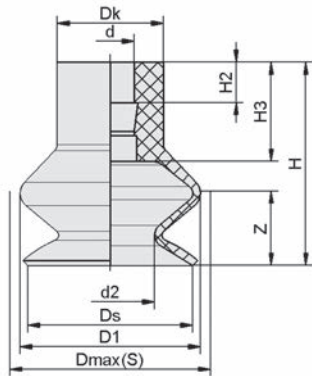

FGA 4, 11 - 25

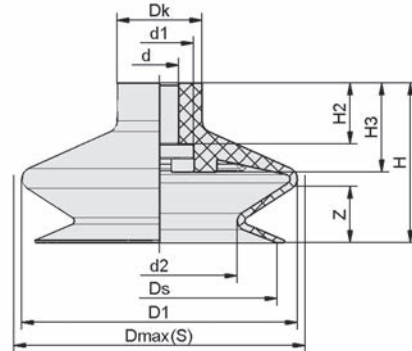

FGA 6, 33 - 78

- Vacuum Suction Cups
- Schmalz - The Company
- Special Grippers
- Gripping Systems
- Clamping Systems
- Mounting Elements
- Vacuum Generators
- Valve Technology
- Switches and Monitoring
- Filters and Connections
- Services
- Contact
- Glossary
- Index of Products

# Bellows Suction Cups FSGA (1.5 Folds)

Suction area (Ø) from 4 mm to 78 mm



## Design Data Bellows Suction Cups FSGA (1.5 Folds)

Type*		d2 [mm]	dn [mm]	Dmax(S) [mm]**	Ds [mm]	G1	H [mm]	LG1 [mm]	SW1 [mm]	Z (Stroke) [mm]	
FSGA	4	M3-AG	2.5	1.0	5.0	4.0	M3-M	5.5	3.0	5	2
FSGA	6	M5-AG	3.0	2.0	8.0	5.7	M5-M	14.0	4.5	8	2
FSGA	6	M5-IG	3.0	2.0	8.0	5.7	M5-F	19.0	5.5	8	2
FSGA	11	M5-AG	5.1	2.5	13.0	10.4	M5-M	21.0	5.0	7	4
FSGA	11	G1/8-AG	5.1	3.5	13.0	10.4	G1/8"-M	22.0	7.5	14	4
FSGA	11	G1/8-IG	5.1	3.5	13.0	10.4	G1/8"-F	28.0	8.0	14	4
FSGA	14	M5-AG	5.0	2.5	14.5	12.5	M5-M	20.5	5.0	7	5
FSGA	14	G1/8-AG	5.0	3.5	14.5	12.5	G1/8"-M	21.5	7.5	14	5
FSGA	14	G1/8-IG	5.0	3.5	14.5	12.5	G1/8"-F	27.5	8.0	14	5
FSGA	16	M5-AG	8.4	2.5	18.5	15.6	M5-M	24.2	5.0	7	7
FSGA	16	G1/8-AG	8.4	3.5	18.5	15.6	G1/8"-M	25.2	7.5	14	7
FSGA	16	G1/8-IG	8.4	3.5	18.5	15.6	G1/8"-F	31.2	8.0	14	7
FSGA	20	M5-AG	11.0	2.5	21.0	18.1	M5-M	20.2	5.0	7	5
FSGA	20	G1/8-AG	11.0	3.5	21.0	18.1	G1/8"-M	21.2	7.5	14	5
FSGA	20	G1/8-IG	11.0	3.5	21.0	18.1	G1/8"-F	27.2	8.0	14	5
FSGA	22	M5-AG	11.7	2.5	25.0	21.5	M5-M	24.0	5.0	7	6
FSGA	22	G1/8-AG	11.7	3.5	25.0	21.5	G1/8"-M	25.0	7.5	14	6
FSGA	22	G1/8-IG	11.7	3.5	25.0	21.5	G1/8"-F	31.0	8.0	14	6
FSGA	25	G1/8-AG	9.9	3.5	26.5	22.5	G1/8"-M	29.0	7.5	14	9
FSGA	25	G1/8-IG	9.9	3.5	26.5	22.5	G1/8"-F	35.0	8.0	14	9
FSGA	33	G1/4-AG	17.0	4.4	38.0	30.0	G1/4"-M	31.0	11.0	17	9
FSGA	33	G1/4-IG	17.0	4.4	38.0	30.0	G1/4"-F	42.0	12.0	17	9
FSGA	43	G1/4-AG	21.9	4.4	47.5	38.0	G1/4"-M	31.6	11.0	17	10
FSGA	43	G1/4-IG	21.9	4.4	47.5	38.0	G1/4"-F	42.6	12.0	17	10
FSGA	53	G1/4-AG	33.0	4.4	60.0	50.0	G1/4"-M	38.0	11.0	17	12
FSGA	53	G1/4-IG	33.0	4.4	60.0	50.0	G1/4"-F	49.0	12.0	17	12
FSGA	63	G1/4-AG	44.5	4.4	68.0	60.0	G1/4"-M	38.0	11.0	17	14
FSGA	63	G1/4-IG	44.5	4.4	68.0	60.0	G1/4"-F	49.0	12.0	17	14
FSGA	78	G1/4-AG	54.0	8.2	84.5	74.0	G1/4"-M	53.0	11.0	21	14
FSGA	78	G1/4-IG	54.0	8.2	86.0	74.0	G1/4"-F	62.0	12.0	21	16

\*Acceptable dimensional tolerances for rubber parts concerning to DIN ISO 3302-1 M3

\*\*External dimension of the suction cup when it is pressed against the workpiece by the vacuum

Type*		d [mm]	d1 [mm]	d2 [mm]	D1 [mm]	Dk [mm]	Dmax(S) [mm]**	Ds [mm]	H [mm]	H2 [mm]	H3 [mm]	Z (Stroke) [mm]
FGA	4	2.0	3.0	2.5	4.6	4.0	5.0	4.0	5.5	1.5	2.6	1.5
FGA	6	3.7	5.8	3.0	7.5	7.2	8.0	5.7	9.0	2.0	3.2	2.0
FGA	11	4.5	-	5.1	12.0	10.0	13.0	10.4	16.0	3.8	9.3	4.0
FGA	14	4.5	-	5.0	13.7	10.0	14.5	12.5	15.5	3.8	8.5	5.0
FGA	16	4.5	-	8.4	17.0	10.0	18.5	15.6	19.2	3.8	9.4	7.0
FGA	20	4.5	-	11.0	19.9	10.0	21.0	18.1	15.2	3.8	8.7	5.0
FGA	22	4.5	-	11.7	24.2	10.0	25.0	21.5	19.0	3.8	9.1	6.0
FGA	25	4.5	-	9.9	25.0	10.0	26.5	22.5	23.0	3.8	8.9	9.0
FGA	33	8.0	16.0	17.0	36.0	18.0	38.0	30.0	27.0	13.0	14.0	9.0
FGA	43	8.0	14.5	21.9	45.9	18.0	47.5	38.0	27.6	13.0	17.1	10.0
FGA	53	8.0	14.5	33.0	58.6	18.0	60.0	50.0	34.0	12.3	19.0	15.0
FGA	63	8.0	14.5	44.5	67.0	18.0	68.0	60.0	34.0	13.0	18.8	15.2
FGA	78	11.8	21.8	54.0	83.0	24.7	84.5	74.0	47.0	19.7	31.4	16.0

\*Acceptable dimensional tolerances for rubber parts concerning to DIN ISO 3302-1 M3

\*\*External dimension of the suction cup when it is pressed against the workpiece by the vacuum



Schmalz – The Company  
Vacuum Suction Cups  
Special Grippers  
Gripping Systems  
Clamping Systems  
Mounting Elements  
Vacuum Generators  
Valve Technology  
Switches and Monitoring  
Filters and Connections  
Services  
Contact  
Glossary  
Index of Products

# Bellows Suction Cups FSGA VU1 (1.5 Folds)

Suction area (Ø) from 30 mm to 110 mm



## Suitability for Industry Specific Applications

### Applications

- Round bellows suction cup with 1.5 folds for use in multi-shift operations with very short cycle times
- Handling of workpieces with very abrasive surfaces such as rough cardboard sheets
- Suction cup with special groove: for handling oily metal sheets (better resistance to lateral forces due to discharge of oil)
- Suction cup without special groove: for handling cardboard, wood and similar materials



Bellows Suction Cups FSGA VU1 (1.5 Folds)

### Design

- Robust, wear-resistant suction cup FSGA (3) with single sealing lip, consisting of suction cup FGA (2) (Vulkollan VU1) with 1.5 folds and connection nipple (1)
- Suction cup connected positively to nipple; no turning even when handling heavy loads
- Suction cups with supports on the bottom
- With each nipple family, the replacement cups and nipples can be combined as desired

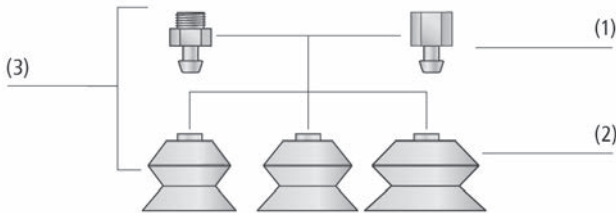

System Design Bellows Suction Cups FSGA VU1 (1.5 Folds)

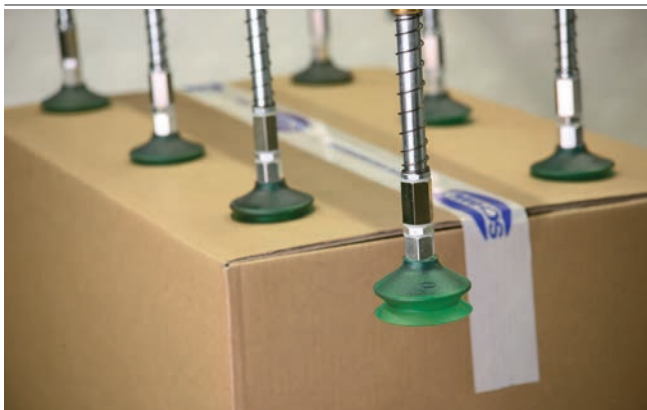

Bellows suction cups FSGA VU1 being used for handling cardboard boxes

### Our Highlights...

- Material Vulkollan VU1 with high resistance to tearing
- Good resistance to chemicals
- Minimum abrasion: approx. 10 - 12 mm<sup>3</sup> to DIN 53516
- Supports on the bottom

### Your Benefits...

- Very wear-resistant suction cup for very high loads and a long lifetime
- Unaffected by oil (handling of sheet metal)
- Lifetime up to 20 times higher compared to standard NBR
- No permanent deformation of thin-walled workpieces

Schmalz – The Company

Vacuum Suction Cups

Special Grippers

Gripping Systems

Clamping Systems

Mounting Elements

Vacuum Generators

Valve Technology

Switches and Monitoring

Filters and Connections

Services

Contact

Glossary

Index of Products



# Bellows Suction Cups FSGA VU1 (1.5 Folds)

Suction area (Ø) from 30 mm to 110 mm



## Designation Code Bellows Suction Cups FSGA VU1 (1.5 Folds)

<b>FSGA</b>	-	<b>60</b>	-	<b>VU1-72</b>	-	<b>G1/4-AG</b>	-	<b>ON</b>
<b>1</b>		<b>2</b>		<b>3</b>		<b>4</b>		<b>5</b>

### 1 – Abbreviated designation

Code	Version
FSGA	1.5 folds

### 2 – Suction area

Code	Diameter in mm
30...110	ø 30 to 110

### 3 – Material

Code	Material
VU1-72	VU1-72

### 4 – Connection

Code	Connection
G1/4-AG	G1/4-AG (AG = male (M))
G1/4-IG	G1/4-IG (IG = female (F))
G1/2-IG	G1/2-IG

### 5 – Product addition

Code	Type
ON	Oil groove

Suction cup FSGA VU1 (elastomer part + connection nipple) is delivered assembled. The assembly consists of:

- Suction cup of type FGA VU1 – elastomer part, available in various diameters, optional with oil groove
- Connection nipple of type SA-NIP – available with various threads

Available spare parts: suction cup FGA VU1, connection nipple SA-NIP / connection disc SA-SCHE



## Ordering Data Bellows Suction Cups FSGA VU1 (1.5 Folds)

Type*	Vacuum connection:		
	G1/4-AG	G1/4-IG	G1/2-IG
FSGA 30 -	10.01.06.00197	10.01.06.00169	-
FSGA 40 ON	10.01.06.00306	10.01.06.00299	-
FSGA 50 ON	10.01.06.00307	10.01.06.00300	-
FSGA 60 -	10.01.06.00242	10.01.06.00240	-
FSGA 60 ON	10.01.06.00198	10.01.06.00172	-
FSGA 85 -	10.01.06.00243	10.01.06.00241	-
FSGA 85 ON	10.01.06.00199	10.01.06.00170	-
FSGA 110 ON	-	-	10.01.06.00497

\*Additional material specifications at beginning of the section "Vacuum Suction Cups"



## Ordering Data Spare Parts Bellows Suction Cups FSGA VU1 (1.5 Folds)

Type	Spare Parts		Part no.
FSGA 30	G1/4-AG	Suction cup connection nipple	SA-NIP N013 G1/4-AG DN350
FSGA 30	G1/4-IG	Suction cup connection nipple	SA-NIP N013 G1/4-IG DN350
FSGA 40	G1/4-AG	Suction cup connection nipple	SA-NIP N011 G1/4-AG DN350
FSGA 40	G1/4-IG	Suction cup connection nipple	SA-NIP N011 G1/4-IG DN350
FSGA 50	G1/4-AG	Suction cup connection nipple	SA-NIP N011 G1/4-AG DN350
FSGA 50	G1/4-IG	Suction cup connection nipple	SA-NIP N011 G1/4-IG DN350
FSGA 60	G1/4-AG	Suction cup connection nipple	SA-NIP N014 G1/4-AG DN600
FSGA 60	G1/4-IG	Suction cup connection nipple	SA-NIP N014 G1/4-IG DN600
FSGA 85	G1/4-AG	Suction cup connection nipple	SA-NIP N015 G1/4-AG DN600
FSGA 85	G1/4-IG	Suction cup connection nipple	SA-NIP N015 G1/4-IG DN600
FSGA 110	G1/2-IG	Suction cup connection disc	SA-SCHE 77 G1/2-IG FSGA



# Bellows Suction Cups FSGA VU1 (1.5 Folds)

Suction area (Ø) from 30 mm to 110 mm



## Ordering Data Spare Parts Bellows Suction Cups FSGA VU1 (1.5 Folds)

Type*				Spare Parts	Part no.	
FSGA	30	VU1-72	-	Bellows suction cup (round)	FGA 30 VU1-72 N013	10.01.06.00177
FSGA	40	VU1-72	ON	Bellows suction cup (round)	FGA 40 VU1-72 N011 ON	10.01.06.00301
FSGA	50	VU1-72	ON	Bellows suction cup (round)	FGA 50 VU1-72 N011 ON	10.01.06.00302
FSGA	60	VU1-72	-	Bellows suction cup (round)	FGA 60 VU1-72 N014	10.01.06.00178
FSGA	60	VU1-72	ON	Bellows suction cup (round)	FGA 60 VU1-72 N014 ON	10.01.06.00207
FSGA	85	VU1-72	ON	Bellows suction cup (round)	FGA 85 VU1-72 N015 ON	10.01.06.00190
FSGA	85	VU1-72	-	Bellows suction cup (round)	FGA 85 VU1-72 N015	10.01.06.00179
FSGA	110	VU1-72	ON	Bellows suction cup (round)	FGA 110 VU1-72 N037 ON	10.01.06.00492

\*Additional material specifications at beginning of the section "Vacuum Suction Cups"



## Technical Data Bellows Suction Cups FSGA VU1 (1.5 Folds)

Type	Suction force [N]*	Pull-off force [N]	Volume [cm³]	Workpiece radius min. (convex) [mm]	Hose diameter (recom.) d [mm]**	Nipple family
FSGA 30	13.50	32	5.8	25	6	N 013
FSGA 40	33.00	56	11.3	30	6	N 011
FSGA 50	52.00	88	22.6	40	6	N 011
FSGA 60	75.00	120	34.3	50	6	N 014
FSGA 85	140.00	250	78.0	80	6	N 015
FSGA 110	295.00	420	350.0	100	9	N 037

\*The specified suction forces are theoretical values at a vacuum of -0.6 bar and with a smooth, dry workpiece surface - they do not include a safety factor

\*\*The recommended hose diameter refers to a hose length of approx. 2 m



## Design Data Bellows Suction Cups FSGA VU1 (1.5 Folds)

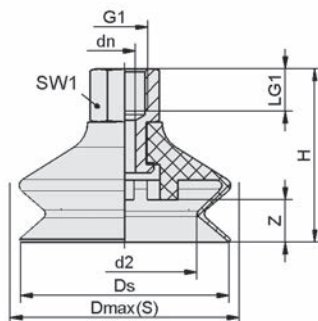

FSGA 30 - 85 VU1 IG

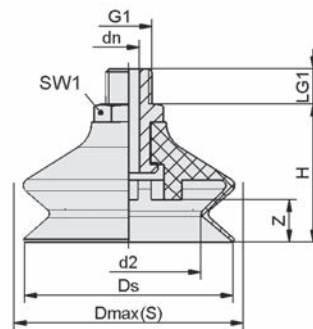

FSGA 30 - 85 VU1 AG



Schmalz - The Company  
Vacuum Suction Cups  
Special Grippers  
Gripping Systems  
Clamping Systems  
Mounting Elements  
Vacuum Generators  
Valve Technology  
Switches and Monitoring  
Filters and Connections  
Services  
Contact  
Glossary  
Index of Products

# Bellows Suction Cups FSGA VU1 (1.5 Folds)

Suction area (Ø) from 30 mm to 110 mm



## Design Data Bellows Suction Cups FSGA VU1 (1.5 Folds)

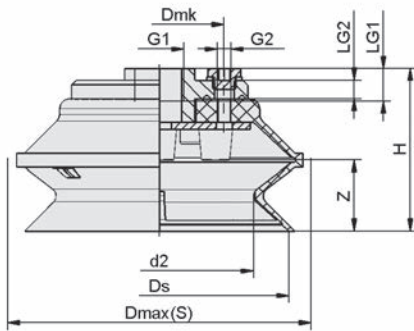

FSGA 110 VU1 IG

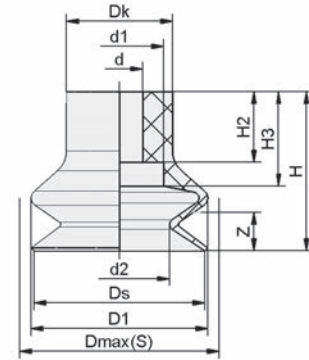

FGA 30 VU1

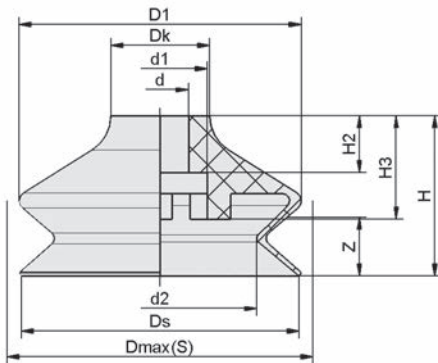

FGA 40 - 85 VU1

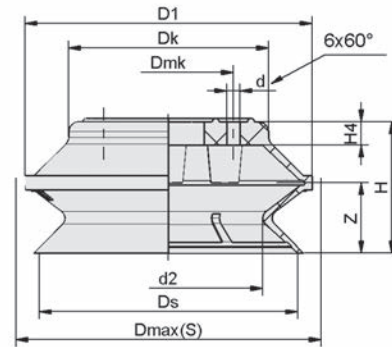

FGA 110 VU1

Type*	d2 [mm]	Dmax(S) [mm]**	Dmk [mm]	dn [mm]	Ds [mm]	G1	G2	H [mm]	LG1 [mm]	LG2 [mm]	SW1 [mm]	Z (Stroke) [mm]
FSGA 30 VU1-72 G1/4-AG	17.0	31.5	-	3.5	29.0	G1/4"-M	-	32.0	10	-	17	9
FSGA 30 VU1-72 G1/4-IG	17.0	31.5	-	3.5	29.0	G1/4"-F	-	42.0	12	-	17	9
FSGA 40 VU1-72 G1/4-AG ON	26.8	42.5	-	3.5	38.0	G1/4"-M	-	31.0	10	-	17	13
FSGA 40 VU1-72 G1/4-IG ON	26.8	42.5	-	3.5	38.0	G1/4"-F	-	41.0	12	-	17	13
FSGA 50 VU1-72 G1/4-AG ON	33.5	53.0	-	3.5	47.0	G1/4"-M	-	37.5	10	-	17	15
FSGA 50 VU1-72 G1/4-IG ON	33.5	53.0	-	3.5	47.0	G1/4"-F	-	47.5	12	-	17	15
FSGA 60 VU1-72 G1/4-AG	41.0	61.5	-	6.0	59.0	G1/4"-M	-	39.0	10	-	17	13
FSGA 60 VU1-72 G1/4-AG ON	40.0	61.5	-	6.0	57.0	G1/4"-M	-	39.0	10	-	17	13
FSGA 60 VU1-72 G1/4-IG	41.0	61.5	-	6.0	59.0	G1/4"-F	-	49.0	12	-	17	13
FSGA 60 VU1-72 G1/4-IG ON	40.0	61.5	-	6.0	57.0	G1/4"-F	-	49.0	12	-	17	13
FSGA 85 VU1-72 G1/4-AG	50.2	86.5	-	6.0	82.5	G1/4"-M	-	52.0	10	-	22	15
FSGA 85 VU1-72 G1/4-AG ON	50.2	86.5	-	6.0	82.5	G1/4"-M	-	52.0	10	-	22	15
FSGA 85 VU1-72 G1/4-IG	50.2	86.5	-	6.0	82.5	G1/4"-F	-	62.0	12	-	22	15
FSGA 85 VU1-72 G1/4-IG ON	50.2	86.5	-	6.0	82.5	G1/4"-F	-	62.0	12	-	22	15
FSGA 110 VU1-72 G1/2-IG ON	80.0	127.0	55.0	-	110.0	G1/2"-F	G1/8"-F	69.0	14	8	-	30

\*Acceptable dimensional tolerances for rubber parts concerning to DIN ISO 3302-1 M3

\*\*External dimension of the suction cup when it is pressed against the workpiece by the vacuum

Schmalz - The Company  
 Vacuum Suction Cups  
 Special Grippers  
 Gripping Systems  
 Clamping Systems  
 Mounting Elements  
 Vacuum Generators  
 Valve Technology  
 Switches and Monitoring  
 Filters and Connections  
 Services  
 Contact  
 Glossary  
 Index of Products

# Bellows Suction Cups FSGA VU1 (1.5 Folds)

Suction area (Ø) from 30 mm to 110 mm



## Design Data Bellows Suction Cups FSGA VU1 (1.5 Folds)

Type*	d [mm]	d1 [mm]	d2 [mm]	Dk [mm]	Dmax(S) [mm]**	Dmk [mm]	Ds [mm]	H [mm]	H2 [mm]	H3 [mm]	H4 [mm]	Z (Stroke) [mm]
FGA 30 VU1-72 N013	8	15.0	17.0	18.0	31.5	-	29.0	27.0	12.0	16.0	-	8.5
FGA 40 VU1-72 N011 ON	8	13.6	26.8	14.0	42.5	-	38.0	27.0	8.0	15.0	-	12.8
FGA 50 VU1-72 N011 ON	8	13.6	33.5	17.5	53.0	-	47.0	32.5	8.0	17.8	-	14.5
FGA 60 VU1-72 N014	12	20.0	41.0	21.0	61.5	-	59.0	34.0	12.0	22.0	-	12.0
FGA 85 VU1-72 N015	12	25.0	55.0	25.0	86.5	-	82.0	47.0	20.0	25.0	-	15.0
FGA 110 VU1-72 N037 ON	6	-	80.0	85.0	127.0	55	110.0	56.0	-	-	10.0	30.0

\*Acceptable dimensional tolerances for rubber parts concerning to DIN ISO 3302-1 M3

\*\*External dimension of the suction cup when it is pressed against the workpiece by the vacuum

- Vacuum Suction Cups
- Special Grippers
- Gripping Systems
- Clamping Systems
- Mounting Elements
- Vacuum Generators
- Valve Technology
- Switches and Monitoring
- Filters and Connections
- Services
- Contact
- Glossary
- Index of Products



# Bellows Suction Cups FSGA (1.5 Folds) from Ø110 mm

Suction area (Ø) 110 mm and 150 mm



Bellows Suction Cups FSGA (1.5 Folds) from Ø110 mm

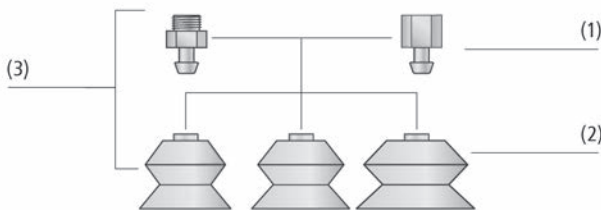

System Design Bellows Suction Cups FSGA (1.5 Folds) from Ø110 mm



Bellows suction cups FSGA being used for handling pressed wooden boards

## Suitability for Industry Specific Applications

### Applications

- Round bellows suction cup with 1.5 folds for handling of cardboard, sheet metal and wood
- Handling of large and heavy workpieces which can easily get damaged (optimal adaptation to convex surfaces)

### Design

- Robust and hard-wearing suction cup FSGA (3) with single sealing lip, consisting of suction cup FGA (2) with 1.5 folds and connection plate (1)
- Connection plate is screwed to suction cup FGA. Suction cup FGA can be replaced separately when worn
- Suction cups with supports on the bottom
- With each nipple family, the replacement cups and nipples can be combined as desired

### Our Highlights...

- Large diameter
- Soft, tapered sealing lip
- 1.5 folds
- Very stiff top fold

### Your Benefits...

- Handling of large, heavy, but sensitive workpieces
- Very good adaptation to curved workpiece surfaces
- High suction force and optimum damping effect during placement on workpiece
- Good resistance to horizontal forces at high acceleration values



# Bellows Suction Cups FSGA (1.5 Folds) from Ø110 mm

Suction area (Ø) 110 mm and 150 mm

Schmalz – The Company  
Vacuum Suction Cups  
Special Grippers  
Gripping Systems  
Clamping Systems  
Mounting Elements  
Vacuum Generators  
Valve Technology  
Switches and Monitoring  
Filters and Connections  
Services  
Contact  
Glossary  
Index of Products



## Designation Code Bellows Suction Cups FSGA (1.5 Folds) from Ø110 mm

<b>FSGA</b>	-	<b>110</b>	-	<b>NBR-70</b>	-	<b>G1/2-IG</b>
1		2		3		4

### 1 – Abbreviated designation

Code	Version
FSGA	1.5 folds

### 2 – Suction area

Code	Diameter in mm
110...150	ø 110 and 150

### 3 – Material

Code	Material
NBR-70	Nitrile caoutchuc
SI-55	Silicone
SI-70	Silicone

### 4 – Connection

Code	Connection
G1/2-IG	G1/2-IG (IG = female (F))

Suction cup FSGA (elastomer part + connection nipple) is delivered assembled. The assembly consists of:

- Suction cup of type FGA – elastomer part, available in the diameters 110 mm and 150 mm and various materials
- Connection nipple of type SA-NIP – available with various threads

Available spare parts: suction cup FGA, connection nipple SA-NIP



## Ordering Data Bellows Suction Cups FSGA (1.5 Folds) from Ø110 mm

Type			Suction cup material with ShA: *		
			NBR-70	SI-55	SI-70
FSGA	110	G1/2-IG	10.01.06.00118	10.01.06.00119	-
FSGA	150	G1/2-IG	10.01.06.00120	-	10.01.06.00121

\*Additional material specifications at beginning of the section "Vacuum Suction Cups"



## Ordering Data Spare Parts Bellows Suction Cups FSGA (1.5 Folds) from Ø110 mm

Type	Spare Parts		Part no.
FSGA 110 NBR-70 G1/2-IG	Bellows suction cup (round)	FGA 110 NBR-70 N010	10.01.06.00114
FSGA 110 SI-55 G1/2-IG	Bellows suction cup (round)	FGA 110 SI-55 N010	10.01.06.00115
FSGA 150 NBR-70 G1/2-IG	Bellows suction cup (round)	FGA 150 NBR-70 N010	10.01.06.00116
FSGA 150 SI-70 G1/2-IG	Bellows suction cup (round)	FGA 150 SI-70 N010	10.01.06.00117

Type	Spare Parts		Part no.
FSGA 110	Suction cup connection nipple (inst)	SA-NIP N010 G1/2-IG	10.01.01.00796
FSGA 150	Suction cup connection nipple (inst)	SA-NIP N010 G1/2-IG	10.01.01.00796



# Bellows Suction Cups FSGA (1.5 Folds) from Ø110 mm

Suction area (Ø) 110 mm and 150 mm



## Technical Data Bellows Suction Cups FSGA (1.5 Folds) from Ø110 mm

Type	Suction force [N]*	Pull-off force [N]	Volume [cm³]	Workpiece radius min. (convex) [mm]	Hose diameter (recom.) d [mm]**	Nipple family
FSGA 110	280	570	330	85	12	N 010
FSGA 150	570	1,000	800	250	12	N 010

\*The specified suction forces are theoretical values at a vacuum of -0.6 bar and with a smooth, dry workpiece surface - they do not include a safety factor

\*\*The recommended hose diameter refers to a hose length of approx. 2 m



## Design Data Bellows Suction Cups FSGA (1.5 Folds) from Ø110 mm

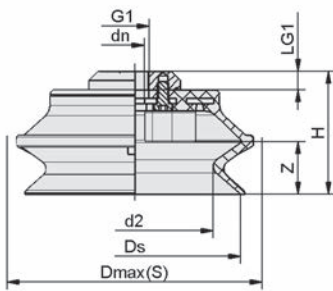

FSGA

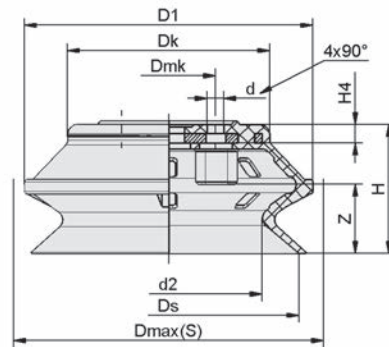

FGA

Type*	dn [mm]	d2 [mm]	Dmax(S) [mm]**	Ds [mm]	G1	H [mm]	LG1 [mm]	Z (Stroke) [mm]
FSGA 110 NBR-70 G1/2-IG	13.5	80	130	111	G1/2"-F	69.5	13	29
FSGA 110 SI-55 G1/2-IG	13.5	80	130	111	G1/2"-F	69.5	13	29
FSGA 150 NBR-70 G1/2-IG	13.5	111	177	150	G1/2"-F	88.5	13	38
FSGA 150 SI-70 G1/2-IG	13.5	111	177	150	G1/2"-F	88.5	13	38

\*Acceptable dimensional tolerances for rubber parts concerning to DIN ISO 3302-1 M3

\*\*External dimension of the suction cup when it is pressed against the workpiece by the vacuum

Type*	d [mm]	d2 [mm]	D1 [mm]	Dk [mm]	Dmax(S) [mm]**	Dmk [mm]	Ds [mm]	H [mm]	H4 [mm]	Z (Stroke) [mm]
FGA 110	7	80	123	86	130	40	111	55.0	8.0	29.5
FGA 150	7	111	168	120	177	40	150	74.0	10.0	37.0

\*Acceptable dimensional tolerances for rubber parts concerning to DIN ISO 3302-1 M3

\*\*External dimension of the suction cup when it is pressed against the workpiece by the vacuum



Schmalz - The Company  
 Vacuum Suction Cups  
 Special Grippers  
 Gripping Systems  
 Clamping Systems  
 Mounting Elements  
 Vacuum Generators  
 Valve Technology  
 Switches and Monitoring  
 Filters and Connections  
 Services  
 Contact  
 Glossary  
 Index of Products

# Bellows Suction Cups FSGPL (1.5 Folds)

Suction area (Ø) from 100 mm to 250 mm



## Suitability for Industry Specific Applications

### Applications

- Round, bellows suction cup with 1.5 folds for handling of cardboard, sheet metal, wood and ceramics
- Handling of workpieces with uneven surfaces (optimal adaptation due to smooth sealing lip)



Bellows Suction Cups FSGPL (1.5 Folds)

### Design

- Suction cup FSGPL with 1.5 folds (2) and vulcanized mounting plate (1)
- Steel mounting plate with female thread
- Lower side of mounting plate covered with an elastomer coating (3)
- Optionally available without threaded hole

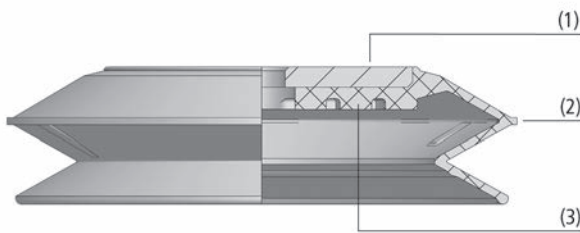

System Design Bellows Suction Cups FSGPL (1.5 Folds)

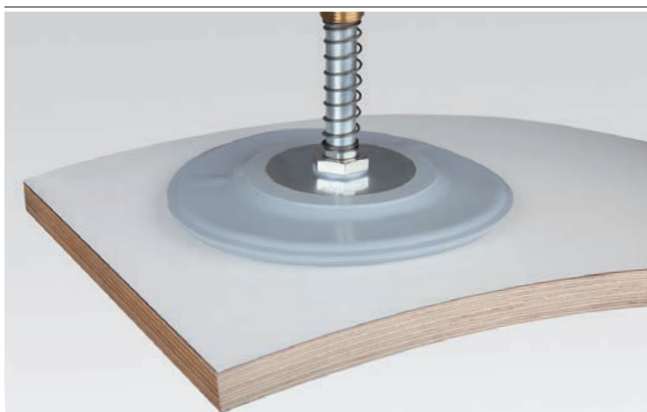

Bellows suction cups FSGPL being used for handling coated wood

### Our Highlights...

- Large diameter
- Very soft, tapered sealing lip
- 1.5 folds
- Elastomer supports on the bottom

### Your Benefits...

- For use with large, heavy but also sensitive workpieces
- Good adaptation to curved workpiece surfaces
- High suction force and damping effect during placement on workpiece
- No permanent deformation or breakage of sensitive workpieces

- Schmalz – The Company
- Vacuum Suction Cups
- Special Grippers
- Gripping Systems
- Clamping Systems
- Mounting Elements
- Vacuum Generators
- Valve Technology
- Switches and Monitoring
- Filters and Connections
- Services
- Contact
- Glossary
- Index of Products



# Bellows Suction Cups FSGPL (1.5 Folds)

Suction area (Ø) from 100 mm to 250 mm



## Designation Code Bellows Suction Cups FSGPL (1.5 Folds)

<b>FSGPL</b>	-	<b>200</b>	-	<b>NBR-55</b>	-	<b>G1/2-IG</b>
1		2		3		4

### 1 – Abbreviated designation

Code	Version
FSGPL	1.5 folds

### 2 – Suction area

Code	Diameter in mm
100...250	ø 100 to 250

### 3 – Material

Code	Material
HT1-60	High temperature material
NBR-55	Nitrile caoutchouc

### 4 – Connection

Code	Connection
G1/2-IG	G1/2-IG (IG = female (F))

Suction cup FSGPL, available in various diameters, is delivered with support plate vulcanized to elastomer part.



## Ordering Data Bellows Suction Cups FSGPL (1.5 Folds)

Type	Suction cup material with ShA: *				
	HT1-60			NBR-55	
FSGPL 100 G1/2-IG	100	G1/2-IG	10.01.06.03150	10.01.06.02932	
FSGPL 120 G1/2-IG	120	G1/2-IG	10.01.06.03151	10.01.06.02933	
FSGPL 150 G1/2-IG	150	G1/2-IG	10.01.06.03145	10.01.06.00101	
FSGPL 200 G1/2-IG	200	G1/2-IG	10.01.06.03146	10.01.06.00102	
FSGPL 250 G1/2-IG	250	G1/2-IG	10.01.06.03421	10.01.06.00103	

\*Additional material specifications at beginning of the section "Vacuum Suction Cups"



## Technical Data Bellows Suction Cups FSGPL (1.5 Folds)

Type	Suction force [N]*	Pull-off force [N]	Volume [cm³]	Workpiece radius min. (convex) [mm]	Hose diameter (recom.) d [mm]**
FSGPL 100	150	250	150	100	12
FSGPL 120	280	400	296	150	12
FSGPL 150	370	500	450	250	12
FSGPL 200	850	950	877	350	12
FSGPL 250	1,610	2,000	1,678	500	12

\*The specified suction forces are theoretical values at a vacuum of -0.6 bar and with a smooth, dry workpiece surface - they do not include a safety factor

\*\*The recommended hose diameter refers to a hose length of approx. 2 m

# Bellows Suction Cups FSGPL (1.5 Folds)

Suction area (Ø) from 100 mm to 250 mm

## Design Data Bellows Suction Cups FSGPL (1.5 Folds)

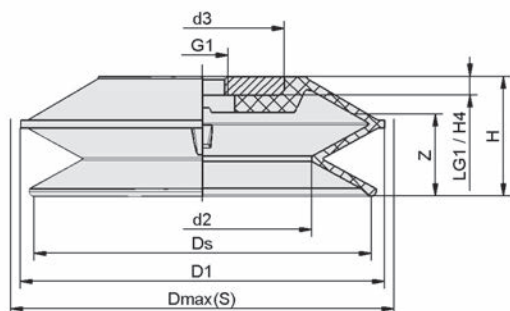

FSGPL

Type*		d2 [mm]	d3 [mm]	D1 [mm]	Dmax(S) [mm]**	Ds [mm]	G1***	H [mm]	H4 [mm]	LG1 [mm]	Z (Stroke) [mm]
FSGPL	100	57.2	44	101	106.5	96.1	G1/2"-F	43.3	8	8	29.1
FSGPL	120	79.3	70	128	135.0	118.2	G1/2"-F	51.0	8	8	35.7
FSGPL	150	93.0	70	155	160.0	143.5	G1/2"-F	51.0	8	8	35.7
FSGPL	200	137.0	120	202	208.0	191.0	G1/2"-F	54.0	8	8	37.2
FSGPL	250	186.0	167	250	256.0	239.3	G1/2"-F	60.0	8	8	43.0

\*Acceptable dimensional tolerances for rubber parts concerning to DIN ISO 3302-1 M3

\*\*External dimension of the suction cup when it is pressed against the workpiece by the vacuum

\*\*\*Mounting plate optionally available without drilled holes

# Bellows Suction Cups FSG (2.5 Folds)

Suction area (Ø) from 3 mm to 88 mm



Bellows Suction Cups FSG (2.5 Folds)

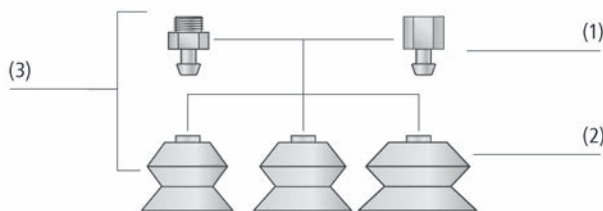

System Design Bellows Suction Cups FSG (2.5 Folds)

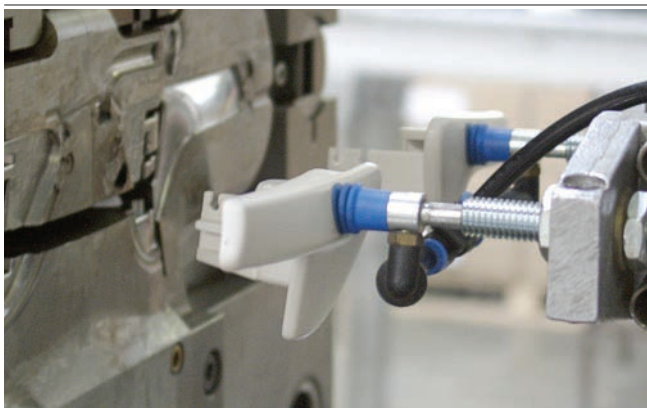

Bellows suction cups FSG being used for handling hot plastic parts

## Suitability for Industry Specific Applications

### Applications

- Round, bellows suction cup with 2.5 folds for handling of extremely sensitive workpieces (optimum damping effect)
- Handling of workpieces with extremely uneven surfaces, such as pipes (optimal adaptation to concave and convex surfaces)
- Internal support (from diameter 52 mm) prevents workpiece from being sucked in
- Special design of the folds permits use in systems with very short cycle times

### Design

- Robust, wear-resistant suction cup FSG (3) with single sealing lip, consisting of suction cup FG (2) with 2.5 folds and connection nipple (1)
- All nipples are plugged in
- Suction cups with a diameter of 52 mm or more with supports on the bottom
- With each nipple family, the replacement cups and nipples can be combined as desired

### Our Highlights...

- Wide range of diameters and materials
- 2.5 folds
- Soft, flexible folds
- Soft, tapered sealing lip
- Supports on the bottom (diameter 52 mm and higher)

### Your Benefits...

- Wide range of workpiece shapes and sizes
- High suction force and optimum damping effect during placement on workpieces
- Very high stroke of suction cup
- Very good adaptation to curved workpiece surfaces
- No permanent deformation of thin-walled workpieces

# Bellows Suction Cups FSG (2.5 Folds)

Suction area (Ø) from 3 mm to 88 mm

## Designation Code Bellows Suction Cups FSG (2.5 Folds)



### 1 – Abbreviated designation

Code	Version
FSG	2.5 folds

### 2 – Suction area

Code	Diameter in mm
3...88	ø 3 to 88

### 3 – Material

Code	Material
HT1-60	High temperature material
NBR-55	Nitrile caoutchuc
NBR-AS-55	Nitrile caoutchuc
NK-45	Natural rubber
SI-55	Silicone
SI-AS-55	Silicone
SI-HD	Silicone

### 4 – Connection

Code	Connection
M3-AG	M3-AG (AG = male (M))
M5-AG	M5-AG
M5-IG	M5-IG (IG = female (F))
G1/8-AG	G1/8-AG
G1/8-IG	G1/8-IG
G1/4-AG	G1/4-AG
G1/4-IG	G1/4-IG

Suction cup FSG (elastomer part + connection nipple) is delivered unassembled. The delivery consists of:

- Suction cup of type FG – elastomer part, available in various diameters and materials
- Connection nipple of type SA-NIP – available with various threads

Available spare parts: suction cup FG, connection nipple SA-NIP

## Ordering Data Bellows Suction Cups FSG (2.5 Folds)

Type			Suction cup material with ShA: *						
			HT1-60	NBR-55	NBR-AS-55	NK-45	SI-55	SI-AS-55	SI-HD
FSG	3	M3-AG	10.01.06.03711	10.01.06.03712	10.01.06.03714	-	10.01.06.03713	10.01.06.03715	-
FSG	3	M5-AG	10.01.06.03716	10.01.06.03717	10.01.06.03719	-	10.01.06.03718	10.01.06.03720	-
FSG	4	M5-AG	10.01.06.02968	10.01.06.02964	10.01.06.03073	-	10.01.06.02966	-	-
FSG	4	M5-IG	10.01.06.02969	10.01.06.02965	10.01.06.03074	-	10.01.06.02967	-	-
FSG	5	M5-AG	10.01.06.01235	10.01.06.00663	-	-	10.01.06.00665	-	-
FSG	5	M5-IG	10.01.06.01242	10.01.06.00662	-	-	10.01.06.00664	-	-
FSG	7	M5-AG	10.01.06.01237	10.01.06.00021	-	-	10.01.06.00035	-	10.01.06.04154
FSG	7	G1/8-AG	10.01.06.01236	10.01.06.00020	-	-	10.01.06.00034	-	10.01.06.04155
FSG	7	G1/8-IG	10.01.06.01243	10.01.06.00001	-	-	10.01.06.00010	-	10.01.06.04156
FSG	9	M5-AG	10.01.06.00963	10.01.06.00023	-	10.01.06.00430	10.01.06.00037	-	10.01.06.04157
FSG	9	G1/8-AG	10.01.06.00962	10.01.06.00022	-	10.01.06.00432	10.01.06.00036	-	10.01.06.04158
FSG	9	G1/8-IG	10.01.06.00978	10.01.06.00002	-	10.01.06.00431	10.01.06.00011	-	10.01.06.04159
FSG	12	M5-AG	10.01.06.01255	10.01.06.00565	-	10.01.06.00567	10.01.06.00566	-	10.01.06.04160
FSG	12	G1/8-AG	10.01.06.01238	10.01.06.00562	-	10.01.06.00564	10.01.06.00563	-	10.01.06.04161
FSG	12	G1/8-IG	10.01.06.01244	10.01.06.00559	-	10.01.06.00561	10.01.06.00560	-	10.01.06.04162
FSG	14	M5-AG	10.01.06.00967	10.01.06.00025	-	10.01.06.00433	10.01.06.00039	-	10.01.06.04163
FSG	14	G1/8-AG	10.01.06.00966	10.01.06.00024	-	10.01.06.00435	10.01.06.00038	-	10.01.06.04164
FSG	14	G1/8-IG	10.01.06.00982	10.01.06.00003	-	10.01.06.00434	10.01.06.00012	-	10.01.06.04165
FSG	18	M5-AG	10.01.06.00969	10.01.06.00027	-	10.01.06.00436	10.01.06.00041	-	10.01.06.04166
FSG	18	G1/8-AG	10.01.06.00968	10.01.06.00026	-	10.01.06.00438	10.01.06.00040	-	10.01.06.04167
FSG	18	G1/8-IG	10.01.06.00984	10.01.06.00004	-	10.01.06.00437	10.01.06.00013	-	10.01.06.04168
FSG	20	M5-AG	10.01.06.01240	10.01.06.00029	-	10.01.06.00439	10.01.06.00043	-	10.01.06.04169



# Bellows Suction Cups FSG (2.5 Folds)

Suction area (Ø) from 3 mm to 88 mm

## Ordering Data Bellows Suction Cups FSG (2.5 Folds)

Type	Suction cup material with ShA: *							
	HT1-60	NBR-55	NBR-AS-55	NK-45	SI-55	SI-AS-55	SI-HD	
FSG 20 G1/8-AG	10.01.06.01239	10.01.06.00028	-	10.01.06.00441	10.01.06.00042	-	10.01.06.04170	
FSG 20 G1/8-IG	10.01.06.01245	10.01.06.00005	-	10.01.06.00440	10.01.06.00014	-	10.01.06.04171	
FSG 25 G1/8-AG	10.01.06.00972	10.01.06.00334	-	10.01.06.00443	10.01.06.00337	-	10.01.06.04172	
FSG 25 G1/8-IG	10.01.06.00988	10.01.06.00333	-	10.01.06.00442	10.01.06.00336	-	10.01.06.04173	
FSG 32 G1/4-AG	10.01.06.01241	10.01.06.00030	-	10.01.06.00445	10.01.06.00044	-	-	
FSG 32 G1/4-IG	10.01.06.01246	10.01.06.00006	-	10.01.06.00444	10.01.06.00015	-	-	
FSG 42 G1/4-AG	10.01.06.00974	10.01.06.00031	-	10.01.06.00447	10.01.06.00045	-	-	
FSG 42 G1/4-IG	10.01.06.00990	10.01.06.00007	-	10.01.06.00446	10.01.06.00016	-	-	
FSG 52 G1/4-AG	10.01.06.02387	10.01.06.00582	-	10.01.06.02385	10.01.06.00586	-	-	
FSG 52 G1/4-IG	10.01.06.02388	10.01.06.00584	-	10.01.06.02386	10.01.06.00587	-	-	
FSG 62 G1/4-AG	10.01.06.02480	10.01.06.00032	-	10.01.06.00449	10.01.06.00046	-	-	
FSG 62 G1/4-IG	10.01.06.02481	10.01.06.00008	-	10.01.06.00448	10.01.06.00017	-	-	
FSG 88 G1/4-AG	-	10.01.06.00033	-	10.01.06.00451	10.01.06.00047	-	-	
FSG 88 G1/4-IG	-	10.01.06.00009	-	10.01.06.00450	10.01.06.00018	-	-	

\*Additional material specifications at beginning of the section "Vacuum Suction Cups"

## Ordering Data Spare Parts Bellows Suction Cups FSG (2.5 Folds)

Type	Suction cup material with ShA: *						
	SI-HD	HT1-60	NBR-55	NBR-AS-55	NK-45	SI-55	SI-AS-55
FG 3	-	10.01.06.03639	10.01.06.03704	10.01.06.03706	-	10.01.06.03705	10.01.06.03707
FG 4	-	10.01.06.02930	10.01.06.02962	10.01.06.03067	-	10.01.06.02963	10.01.06.03277
FG 5	-	10.01.06.01250	10.01.06.00640	10.01.06.00641	-	10.01.06.00642	10.01.06.00643
FG 7	10.01.06.03901	10.01.06.01251	10.01.06.00050	-	-	10.01.06.00055	10.01.06.00508
FG 9	10.01.06.03148	10.01.06.00878	10.01.06.00051	10.01.06.03259	10.01.06.00452	10.01.06.00056	10.01.06.03260
FG 12	10.01.06.04141	10.01.06.01252	10.01.06.00557	-	10.01.06.00558	10.01.06.00549	10.01.06.03360
FG 14	10.01.06.04055	10.01.06.00880	10.01.06.00052	-	10.01.06.00453	10.01.06.00057	10.01.06.03394
FG 18	10.01.06.04148	10.01.06.00881	10.01.06.00053	10.01.06.03400	10.01.06.00454	10.01.06.00058	-
FG 19	-	10.01.06.02611	-	-	10.01.06.02612	10.01.06.02265	-
FG 20	10.01.06.04149	10.01.06.01253	10.01.06.00054	-	10.01.06.00455	10.01.06.00059	-
FG 25	10.01.06.03246	10.01.06.00883	10.01.06.00335	-	10.01.06.00456	10.01.06.00338	-
FG 32	-	10.01.06.01254	10.01.06.00140	-	10.01.06.00457	10.01.06.00144	-
FG 42	-	10.01.06.00885	10.01.06.00141	-	10.01.06.00458	10.01.06.00145	-
FG 52	-	10.01.06.02365	10.01.06.00583	-	10.01.06.02382	10.01.06.00585	-
FG 62	-	10.01.06.02475	10.01.06.00142	-	10.01.06.00459	10.01.06.00146	-
FG 88	-	-	10.01.06.00143	-	10.01.06.00460	10.01.06.00147	-

\*Additional material specifications at beginning of the section "Vacuum Suction Cups"

Type	Spare Parts		Part no.
FSG 3 M3-AG	Suction cup connection nipple	SA-NIP N055 M3-AG DN100	10.01.01.00313
FSG 3 M5-AG	Suction cup connection nipple	SA-NIP N055 M5-AG DN100	10.01.01.13084
FSG 4 M5-AG	Suction cup connection nipple	SA-NIP N017 M5-AG DN200	10.01.06.00314
FSG 5 M5-AG	Suction cup connection nipple	SA-NIP N017 M5-AG DN200	10.01.06.00314
FSG 7 M5-AG	Suction cup connection nipple	SA-NIP N016 M5-AG DN250	10.01.06.00123
FSG 7 G1/8-AG	Suction cup connection nipple	SA-NIP N016 G1/8-AG DN350	10.01.06.05735
FSG 9 M5-AG	Suction cup connection nipple	SA-NIP N016 M5-AG DN250	10.01.06.00123
FSG 9 G1/8-AG	Suction cup connection nipple	SA-NIP N016 G1/8-AG DN350	10.01.06.05735



Schmalz – The Company  
Vacuum Suction Cups  
Special Grippers  
Gripping Systems  
Clamping Systems  
Mounting Elements  
Vacuum Generators  
Valve Technology  
Switches and Monitoring  
Filters and Connections  
Services  
Contact  
Glossary  
Index of Products

# Bellows Suction Cups FSG (2.5 Folds)

Suction area (Ø) from 3 mm to 88 mm



## Ordering Data Spare Parts Bellows Suction Cups FSG (2.5 Folds)

Type	Spare Parts			Part no.
FSG 12	M5-AG	Suction cup connection nipple	SA-NIP N016 M5-AG DN250	10.01.06.00123
FSG 12	G1/8-AG	Suction cup connection nipple	SA-NIP N016 G1/8-AG DN350	10.01.06.05735
FSG 14	M5-AG	Suction cup connection nipple	SA-NIP N016 M5-AG DN250	10.01.06.00123
FSG 14	G1/8-AG	Suction cup connection nipple	SA-NIP N016 G1/8-AG DN350	10.01.06.05735
FSG 18	M5-AG	Suction cup connection nipple	SA-NIP N016 M5-AG DN250	10.01.06.00123
FSG 18	G1/8-AG	Suction cup connection nipple	SA-NIP N016 G1/8-AG DN350	10.01.06.05735
FSG 20	M5-AG	Suction cup connection nipple	SA-NIP N016 M5-AG DN250	10.01.06.00123
FSG 20	G1/8-AG	Suction cup connection nipple	SA-NIP N016 G1/8-AG DN350	10.01.06.05735
FSG 25	G1/8-AG	Suction cup connection nipple	SA-NIP N016 G1/8-AG DN350	10.01.06.05735
FSG 32	G1/4-AG	Suction cup connection nipple	SA-NIP N018 G1/4-AG DN440	10.01.06.01065
FSG 42	G1/4-AG	Suction cup connection nipple	SA-NIP N018 G1/4-AG DN440	10.01.06.01065
FSG 62	G1/4-AG	Suction cup connection nipple	SA-NIP N018 G1/4-AG DN440	10.01.06.01065
FSG 88	G1/4-AG	Suction cup connection nipple	SA-NIP N019 G1/4-AG DN820	10.01.06.01959

Type	Spare Parts			Part no.
FSG 4	M5-IG	Suction cup connection nipple	SA-NIP N017 M5-IG DN200	10.01.06.00313
FSG 5	M5-IG	Suction cup connection nipple	SA-NIP N017 M5-IG DN200	10.01.06.00313
FSG 7	G1/8-IG	Suction cup connection nipple	SA-NIP N016 G1/8-IG DN350	10.01.06.05731
FSG 9	G1/8-IG	Suction cup connection nipple	SA-NIP N016 G1/8-IG DN350	10.01.06.05731
FSG 12	G1/8-IG	Suction cup connection nipple	SA-NIP N016 G1/8-IG DN350	10.01.06.05731
FSG 14	G1/8-IG	Suction cup connection nipple	SA-NIP N016 G1/8-IG DN350	10.01.06.05731
FSG 18	G1/8-IG	Suction cup connection nipple	SA-NIP N016 G1/8-IG DN350	10.01.06.05731
FSG 20	G1/8-IG	Suction cup connection nipple	SA-NIP N016 G1/8-IG DN350	10.01.06.05731
FSG 25	G1/8-IG	Suction cup connection nipple	SA-NIP N016 G1/8-IG DN350	10.01.06.05731
FSG 32	G1/4-IG	Suction cup connection nipple	SA-NIP N018 G1/4-IG DN440	10.01.06.01066
FSG 42	G1/4-IG	Suction cup connection nipple	SA-NIP N018 G1/4-IG DN440	10.01.06.01066
FSG 52	G1/4-IG	Suction cup connection nipple	SA-NIP N018 G1/4-IG DN440	10.01.06.01066
FSG 62	G1/4-IG	Suction cup connection nipple	SA-NIP N018 G1/4-IG DN440	10.01.06.01066
FSG 88	G1/4-IG	Suction cup connection nipple	SA-NIP N019 G1/4-IG DN820	10.01.06.01960



## Technical Data Bellows Suction Cups FSG (2.5 Folds)

Type	Suction force [N]*	Pull-off force [N]**	Volume [cm <sup>3</sup> ]	Workpiece radius min. (convex) [mm]	Hose diameter (recom.) d [mm]***	Nipple family
FSG 3	0.2	0.4	0.022	4	2	N 055
FSG 4	0.3	0.6	0.053	4	2	N 017
FSG 5	0.4	0.8	0.033	8	2	N 017
FSG 7	0.2	0.9	0.043	8	4	N 016
FSG 9	0.8	2.3	0.150	10	4	N 016
FSG 12	1.2	3.5	0.600	13	4	N 016
FSG 14	1.4	5.7	0.975	15	4	N 016
FSG 18	3.1	8.5	1.350	20	4	N 016
FSG 20	5.2	12.1	2.298	30	4	N 016
FSG 25	4.8	19.0	5.400	30	4	N 016

# Bellows Suction Cups FSG (2.5 Folds)

Suction area ( $\varnothing$ ) from 3 mm to 88 mm



## Technical Data Bellows Suction Cups FSG (2.5 Folds)

Type	Suction force [N]*	Pull-off force [N]**	Volume [cm <sup>3</sup> ]	Workpiece radius min. (convex) [mm]	Hose diameter (recom.) d [mm]***	Nipple family
FSG 32	12.1	36.9	10.000	35	6	N 018
FSG 42	15.0	44.0	19.786	75	6	N 018
FSG 52	28.6	96.0	37.587	75	6	N 018
FSG 62	41.1	137.0	72.500	75	6	N 018
FSG 88	40.5	286.0	143.668	100	9	N 019

\*The specified suction forces are theoretical values at a vacuum of -0.6 bar and with a smooth, dry workpiece surface - they do not include a safety factor

\*\*The pull-off force of the versions made of natural rubber is reduced by about 40 %

\*\*\*The recommended hose diameter refers to a hose length of approx. 2 m



## Design Data Bellows Suction Cups FSG (2.5 Folds)

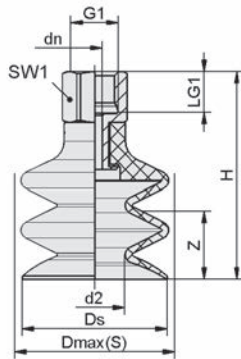

FSG IG

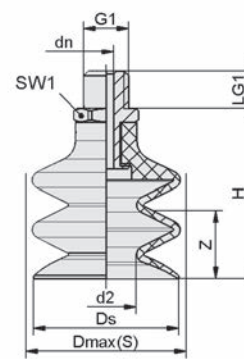

FSG AG

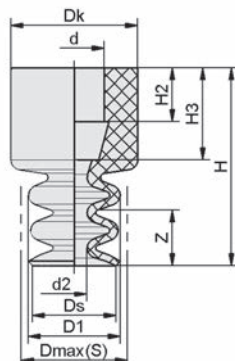

FG 3, 4, 7, 9

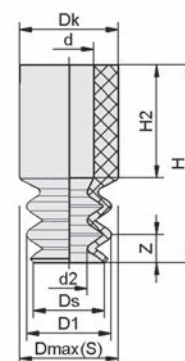

FG 5, 52, 62

# Bellows Suction Cups FSG (2.5 Folds)

Suction area (Ø) from 3 mm to 88 mm

**Design Data Bellows Suction Cups FSG (2.5 Folds)**

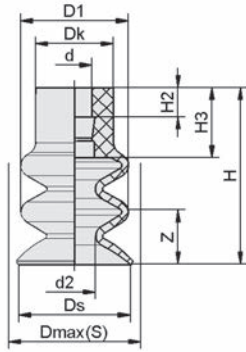

FG 12 - 25

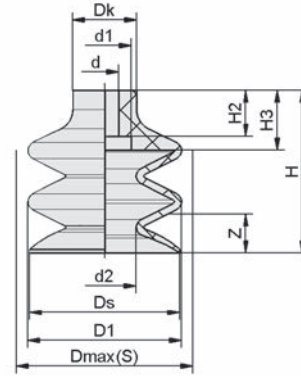

FG 32 - 88

Type*	d2 [mm]	dn [mm]	Dmax(S) [mm]**	Ds [mm]	G1	H [mm]	LG1 [mm]	SW1 [mm]	Z (Stroke) [mm]
FSG 3 M3-AG	1.8	1.0	4.0	3.0	M3-M	8.7	3.0	5	2
FSG 3 M5-AG	1.8	1.0	4.0	3.0	M5-M	10.2	4.5	7	2
FSG 4 M5-AG	2.4	2.0	7.0	3.8	M5-M	19.0	5.0	8	2
FSG 4 M5-IG	2.4	2.0	7.0	3.8	M5-F	24.0	5.5	8	2
FSG 5 M5-AG	2.6	2.0	7.0	5.0	M5-M	19.0	5.0	8	2
FSG 5 M5-IG	2.6	2.0	7.0	5.0	M5-F	24.0	5.5	8	2
FSG 7 M5-AG	1.8	2.5	9.0	5.9	M5-M	19.0	5.0	7	3
FSG 7 G1/8-AG	1.8	3.5	9.0	5.9	G1/8"-M	20.0	7.5	14	3
FSG 7 G1/8-IG	1.8	3.5	9.0	5.9	G1/8"-F	26.0	8.5	14	3
FSG 9 M5-AG	4.1	2.5	9.5	9.0	M5-M	20.0	5.0	7	3
FSG 9 G1/8-AG	4.1	3.5	9.5	9.0	G1/8"-M	21.0	7.5	14	3
FSG 9 G1/8-IG	4.1	3.5	9.5	9.0	G1/8"-F	27.0	8.5	14	3
FSG 12 M5-AG	5.0	2.5	13.0	12.0	M5-M	26.0	5.0	7	7
FSG 12 G1/8-AG	5.0	3.5	13.0	12.0	G1/8"-M	27.0	7.5	14	7
FSG 12 G1/8-IG	5.0	3.5	13.0	12.0	G1/8"-F	33.0	8.5	14	7
FSG 14 M5-AG	5.4	2.5	15.5	14.5	M5-M	27.8	5.0	7	9
FSG 14 G1/8-AG	5.4	3.5	15.5	14.5	G1/8"-M	28.8	7.5	14	9
FSG 14 G1/8-IG	5.4	3.5	15.5	14.5	G1/8"-F	34.8	8.5	14	9
FSG 18 M5-AG	8.0	2.5	19.0	17.2	M5-M	27.6	5.0	7	9
FSG 18 G1/8-AG	8.0	3.5	19.0	17.2	G1/8"-M	28.6	7.5	14	9
FSG 18 G1/8-IG	8.0	3.5	19.0	17.2	G1/8"-F	34.6	8.0	14	9
FSG 20 M5-AG	10.5	2.5	21.0	20.0	M5-M	27.1	5.0	7	9
FSG 20 G1/8-AG	10.5	3.5	21.0	20.0	G1/8"-M	28.1	7.5	14	9
FSG 20 G1/8-IG	10.5	3.5	21.0	20.0	G1/8"-F	34.1	8.0	14	9
FSG 25 G1/8-AG	10.0	3.5	26.0	23.0	G1/8"-M	40.0	7.5	14	18
FSG 25 G1/8-IG	10.0	3.5	26.0	23.0	G1/8"-F	46.0	8.0	14	18
FSG 32 G1/4-AG	16.0	4.4	33.5	32.0	G1/4"-M	41.5	11.0	17	15
FSG 32 G1/4-IG	16.0	4.4	33.5	32.0	G1/4"-F	52.5	12.0	17	15
FSG 42 G1/4-AG	17.8	4.4	45.0	42.6	G1/4"-M	50.0	11.0	17	20
FSG 42 G1/4-IG	17.8	4.4	45.0	42.6	G1/4"-F	61.0	12.0	17	20



# Bellows Suction Cups FSG (2.5 Folds)

Suction area (Ø) from 3 mm to 88 mm



## Design Data Bellows Suction Cups FSG (2.5 Folds)

Type*			d2 [mm]	dn [mm]	Dmax(S) [mm]**	Ds [mm]	G1	H [mm]	LG1 [mm]	SW1 [mm]	Z (Stroke) [mm]
FSG	62	G1/4-AG	29.5	4.4	65.0	62.2	G1/4"-M	58.0	11.0	17	29
FSG	62	G1/4-IG	29.5	4.4	65.0	62.2	G1/4"-F	69.0	12.0	17	29
FSG	88	G1/4-AG	29.3	8.2	95.5	89.0	G1/4"-M	92.5	11.0	21	34
FSG	88	G1/4-IG	29.3	8.2	95.5	89.0	G1/4"-F	101.5	12.0	21	34

\*Acceptable dimensional tolerances for rubber parts concerning to DIN ISO 3302-1 M3

\*\*External dimension of the suction cup when it is pressed against the workpiece by the vacuum

Type*		d [mm]	d2 [mm]	D1 [mm]	Dk [mm]	Dmax(S) [mm]**	Ds [mm]	H [mm]	H2 [mm]	H3 [mm]	Z (Stroke) [mm]
FG	3	1.7	1.8	3.6	3.6	4.0	3.0	6.7	2.1	2.7	1.1
FG	4	3.5	2.4	5.1	7.0	5.5	3.8	14.0	3.9	7.0	1.5
FG	5	3.5	2.6	6.0	7.0	6.5	5.0	14.0	8.0	-	2.0
FG	7	4.5	1.8	6.5	9.0	7.0	5.9	14.0	3.8	6.5	3.0
FG	9	4.5	4.1	8.9	9.0	9.5	9.0	15.0	3.8	8.2	3.0
FG	12	4.5	5.0	12.0	10.0	13.0	12.0	21.0	3.8	6.5	7.0
FG	14	4.5	5.4	13.9	10.0	15.5	14.5	22.8	3.8	6.5	9.0
FG	18	4.5	8.0	17.8	10.0	19.0	17.2	22.6	3.8	6.5	9.0
FG	20	4.5	10.5	20.0	10.0	21.0	20.0	22.1	3.8	6.5	9.0
FG	25	4.5	10.0	25.0	10.0	26.0	23.0	34.0	3.8	6.5	18.0
FG	32	8.0	16.0	32.4	18.0	33.5	32.0	37.5	13.0	17.0	15.0
FG	42	8.0	17.8	43.5	18.0	45.0	42.6	46.0	13.0	17.0	20.0
FG	52	8.0	24.6	52.0	18.0	55.0	52.5	48.7	13.0	-	25.0
FG	62	8.0	29.5	62.0	18.0	65.0	62.2	54.0	13.0	-	29.0
FG	88	11.7	29.3	88.2	24.7	95.5	89.0	86.5	19.7	26.0	34.0

\*Acceptable dimensional tolerances for rubber parts concerning to DIN ISO 3302-1 M3

\*\*External dimension of the suction cup when it is pressed against the workpiece by the vacuum

# Bellows Suction Cups FSG VU1 (2.5 Folds)

Suction area (Ø) from 30 mm to 85 mm



## Suitability for Industry Specific Applications

### Applications

- Round bellows suction cup with 2.5 folds for use in multi-shift operations with very short cycle times
- Handling of workpieces with very abrasive surfaces
- Suction cup with special groove: for handling oily metal sheets (better handling of lateral forces due to discharge of oil)
- Suction cup without special groove: for handling cardboard, wood and similar materials



Bellows Suction Cups FSG VU1 (2.5 Folds)

### Design

- Robust and wear-resistant suction cup FSG (3) with single sealing lip, consisting of suction cup FG (2) (Vulkollan VU1) with 2.5 folds and connection nipple (1)
- Suction cup positively connected to nipple to prevent turning, even when lifting heavy loads
- With each nipple family, the replacement cups and nipples can be combined as desired

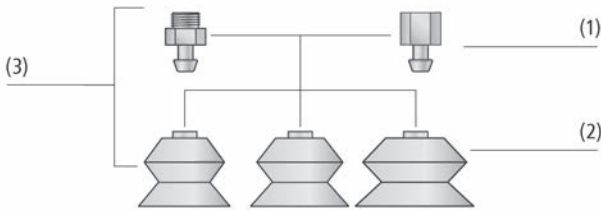

System Design Bellows Suction Cups FSG VU1 (2.5 Folds)

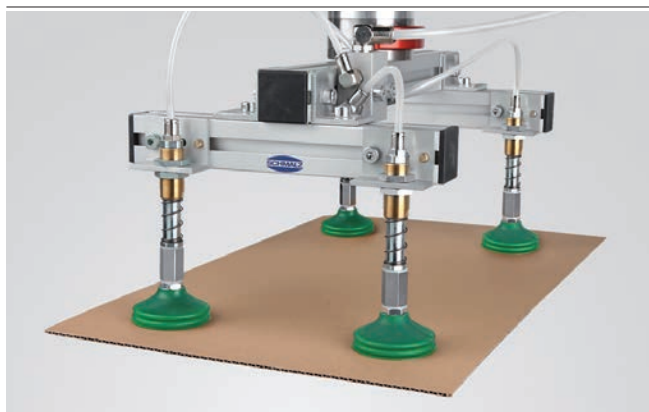

Bellows suction cups FSG VU1 being used for handling corrugated cardboard

### Our Highlights...

- Material Vulkollan VU1 with high resistance to tearing
- Good resistance to chemicals
- Minimum abrasion, approx. 10 - 12 mm<sup>3</sup> to DIN 53516
- Supports on the bottom

### Your Benefits...

- Very wear-resistant suction cup for very high loading and a long lifetime
- Unaffected by oil (handling of sheet metal)
- Lifetime up to 20 times longer compared to standard NBR
- No permanent deformation of thin-walled workpieces

Schmalz – The Company  
Vacuum Suction Cups  
Special Grippers  
Gripping Systems  
Clamping Systems  
Mounting Elements  
Vacuum Generators  
Valve Technology  
Switches and Monitoring  
Filters and Connections  
Services  
Contact  
Glossary  
Index of Products

# Bellows Suction Cups FSG VU1 (2.5 Folds)

Suction area (Ø) from 30 mm to 85 mm



## Designation Code Bellows Suction Cups FSG VU1 (2.5 Folds)

<b>FSG</b>	-	<b>60</b>	-	<b>VU1-72</b>	-	<b>G1/4-AG</b>	-	<b>ON</b>
<b>1</b>		<b>2</b>		<b>3</b>		<b>4</b>		<b>5</b>

### 1 – Abbreviated designation

Code	Version
FSG	2.5 folds

### 2 – Suction area

Code	Diameter in mm
30...85	ø 30 to 85

### 3 – Material

Code	Material
VU1-72	VU1-72

### 4 – Connection

Code	Connection
G1/4-AG	G1/4-AG (AG = male (M))
G1/4-IG	G1/4-IG (IG = female (F))

### 5 – Product addition

Code	Type
ON	Oil groove

Suction cup FSG VU1 (elastomer part + connection nipple) is delivered assembled. The assembly consists of:

- Suction cup of type FG VU1 – elastomer part, available in various diameters
- Connection nipple of type SA-NIP – available with various threads

Available spare parts: suction cup FG VU1, connection nipple SA-NIP



## Ordering Data Bellows Suction Cups FSG VU1 (2.5 Folds)

Type*				Vacuum connection:	
				G1/4-AG	G1/4-IG
FSG	30	VU1-72	-	10.01.06.00200	10.01.06.00166
FSG	60	VU1-72	-	10.01.06.00238	10.01.06.00236
FSG	60	VU1-72	ON	10.01.06.00201	10.01.06.00171
FSG	85	VU1-72	-	10.01.06.00239	10.01.06.00237
FSG	85	VU1-72	ON	10.01.06.00202	10.01.06.00167

\*Additional material specifications at beginning of the section "Vacuum Suction Cups"



## Ordering Data Spare Parts Bellows Suction Cups FSG VU1 (2.5 Folds)

Type	Spare Parts			Part no.
FSG 30 VU1-72 -	Bellows suction cup (round)	FG 30 VU1-72 N013		10.01.06.00173
FSG 60 VU1-72 -	Bellows suction cup (round)	FG 60 VU1-72 N014		10.01.06.00174
FSG 60 VU1-72 ON	Bellows suction cup (round)	FG 60 VU1-72 N014 ON		10.01.06.00208
FSG 85 VU1-72 -	Bellows suction cup (round)	FG 85 VU1-72 N015		10.01.06.00175
FSG 85 VU1-72 ON	Bellows suction cup (round)	FG 85 VU1-72 N015 ON		10.01.06.00209

Type	Spare Parts		Part no.
FSG 30 VU1-72 G1/4-AG	Suction cup connection nipple	SA-NIP N013 G1/4-AG DN350	10.01.06.00183
FSG 30 VU1-72 G1/4-IG	Suction cup connection nipple	SA-NIP N013 G1/4-IG DN350	10.01.06.00180
FSG 60 VU1-72 G1/4-AG	Suction cup connection nipple	SA-NIP N014 G1/4-AG DN600	10.01.06.00184
FSG 60 VU1-72 G1/4-IG	Suction cup connection nipple	SA-NIP N014 G1/4-IG DN600	10.01.06.00181
FSG 85 VU1-72 G1/4-AG	Suction cup connection nipple	SA-NIP N015 G1/4-AG DN600	10.01.06.00185
FSG 85 VU1-72 G1/4-IG	Suction cup connection nipple	SA-NIP N015 G1/4-IG DN600	10.01.06.00182



Schmalz – The Company  
Vacuum Suction Cups  
Special Grippers  
Gripping Systems  
Clamping Systems  
Mounting Elements  
Vacuum Generators  
Valve Technology  
Switches and Monitoring  
Filters and Connections  
Services  
Contact  
Glossary  
Index of Products

# Bellows Suction Cups FSG VU1 (2.5 Folds)

Suction area (Ø) from 30 mm to 85 mm

## Technical Data Bellows Suction Cups FSG VU1 (2.5 Folds)

Type	Suction force [N]*	Pull-off force [N]	Volume [cm³]	Workpiece radius min. (convex) [mm]	Hose diameter (recom.) d [mm]**	Nipple family
FSG 30 -	13.5	32	8.5	25	6	N 013
FSG 60 -	61.0	100	61.0	50	6	N 014
FSG 60 ON	61.0	100	66.8	50	6	N 014
FSG 85 -	120.0	250	201.3	60	6	N 015
FSG 85 ON	120.0	250	201.6	60	6	N 015

\*The specified suction forces are theoretical values at a vacuum of -0.6 bar and with a smooth, dry workpiece surface - they do not include a safety factor

\*\*The recommended hose diameter refers to a hose length of approx. 2 m

## Design Data Bellows Suction Cups FSG VU1 (2.5 Folds)

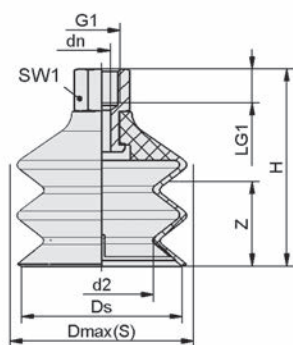

FSG VU1 IG

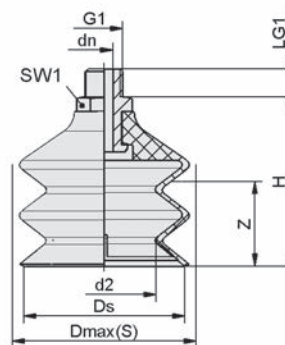

FSG VU1 AG

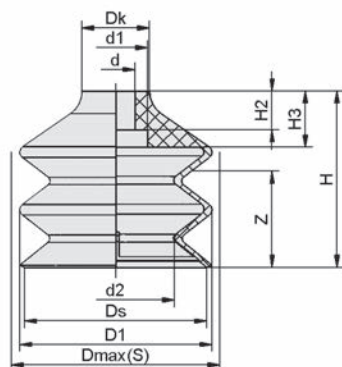

FG VU1

Schmalz - The Company  
 Vacuum Suction Cups  
 Special Grippers  
 Gripping Systems  
 Clamping Systems  
 Mounting Elements  
 Vacuum Generators  
 Valve Technology  
 Switches and Monitoring  
 Filters and Connections  
 Services  
 Contact  
 Glossary  
 Index of Products

# Bellows Suction Cups FSG VU1 (2.5 Folds)

Suction area (Ø) from 30 mm to 85 mm



## Design Data Bellows Suction Cups FSG VU1 (2.5 Folds)

Type*	d2 [mm]	dn [mm]	Dmax(S) [mm]**	Ds [mm]	G1	H [mm]	LG1 [mm]	SW1 [mm]	Z (Stroke) [mm]
FSG 30 VU1-72 G1/4-AG	15	3.5	31.5	29.0	G1/4"-M	45.0	10	17	15
FSG 30 VU1-72 G1/4-IG	15	3.5	31.5	29.0	G1/4"-F	55.0	12	17	15
FSG 60 VU1-72 G1/4-AG	36	6.0	62.5	59.0	G1/4"-M	60.0	10	17	30
FSG 60 VU1-72 G1/4-IG	36	6.0	62.5	59.0	G1/4"-F	70.0	12	17	30
FSG 60 VU1-72 G1/4-AG ON	36	6.0	62.5	59.0	G1/4"-M	60.0	10	17	30
FSG 60 VU1-72 G1/4-IG ON	36	6.0	62.5	59.0	G1/4"-F	70.0	12	17	30
FSG 85 VU1-72 G1/4-AG	51	6.0	90.0	80.2	G1/4"-M	90.0	10	22	38
FSG 85 VU1-72 G1/4-IG	51	6.0	90.0	80.2	G1/4"-F	100.0	12	22	38
FSG 85 VU1-72 G1/4-AG ON	51	6.0	90.0	80.2	G1/4"-M	90.0	10	22	38
FSG 85 VU1-72 G1/4-IG ON	51	6.0	90.0	80.2	G1/4"-F	100.0	12	22	38

\*Acceptable dimensional tolerances for rubber parts concerning to DIN ISO 3302-1 M3

\*\*External dimension of the suction cup when it is pressed against the workpiece by the vacuum

Type*	d	d1	d2	D1	Dk	Dmax(S)	Ds	H	H2	H3	Z (Stroke)
	[mm]	[mm]	[mm]	[mm]	[mm]	[mm]**	[mm]	[mm]	[mm]	[mm]	[mm]
FG 30	8	15	15	30	18	31.5	29.0	40	12	16	15.0
FG 60	12	20	36	60	21	62.5	59.0	55	12	18	30.0
FG 85	12	25	51	85	25	90.0	80.2	85	20	27	45.5

\*Acceptable dimensional tolerances for rubber parts concerning to DIN ISO 3302-1 M3

\*\*External dimension of the suction cup when it is pressed against the workpiece by the vacuum

# Bellows Suction Cups FSGAO (1.5 Folds)

Suction area (LxW) 95 x 40 mm and 140 x 65 mm



## Suitability for Industry Specific Applications

### Applications

- Oval bellows suction cup with 1.5 folds for use in multi-shift operations with very short cycle times
- Handling of oily and narrow, curved metal sheet
- Handling of cardboard, wood and similar materials under rough operating conditions
- Handling of workpieces with extremely abrasive surfaces such as rough cardboard sheets



Bellows Suction Cups FSGAO (1.5 Folds)

### Design

- Suction cup FSGAO, consisting of suction cup FGAO (Vulkollan VU1) with 1.5 folds (3) and connection plate (1)
- Connection plate screwed (2) to suction cup and capable of handling very heavy loads
- The suction cup can be replaced separately when worn

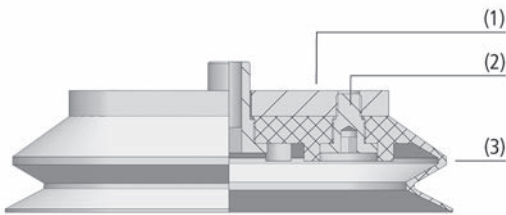

System Design Bellows Suction Cups FSGAO (1.5 Folds)



Bellows suction cups FSGAO being used for handling metal beams

### Our Highlights...

- Material Vulkollan VU1 with high resistance to tearing
- Good resistance to chemicals
- Minimum abrasion: approx. 10 - 12 mm<sup>3</sup> to DIN 53516
- 1.5 folds

### Your Benefits...

- Very wear-resistant suction cup for heavy loads and a long lifetime
- Unaffected by oil (handling of sheet-metal parts)
- Lifetime up to 20 times longer compared to standard NBR
- High suction force and optimum damping effect during placement on the workpiece

# Bellows Suction Cups FSGAO (1.5 Folds)

Suction area (LxW) 95 x 40 mm and 140 x 65 mm



## Designation Code Bellows Suction Cups FSGAO (1.5 Folds)

<b>FSGAO</b>	-	<b>95x40</b>	-	<b>VU1-72</b>	-	<b>G1/8-AG</b>
<b>1</b>		<b>2</b>		<b>3</b>		<b>4</b>

### 1 – Abbreviated designation

Code	Version
FSGAO	1.5 folds, oval

### 2 – Suction area

Code	LxW in mm
95x40...140x65	95x40 and 140x65

### 3 – Material

Code	Material
VU1-72	VU1-72

### 4 – Connection

Code	Connection
G1/8-AG	G1/8-AG (AG = male (M))
G1/4-AG	G1/4-AG

Suction cup FSGAO (elastomer part + support plate) is delivered assembled. The assembly consists of:

- Suction cup of type FGAO – elastomer part, available in various dimensions (LxW)
- Aluminum support plate

Available spare parts: suction cup FGAO



## Ordering Data Bellows Suction Cups FSGAO (1.5 Folds)

Type*	Part no.
FSGAO 95x40 VU1-72 G1/8-AG	10.01.06.00503
FSGAO 140x65 VU1-72 G1/4-AG	10.01.06.00498

\*Additional material specifications at beginning of the section "Vacuum Suction Cups"



## Ordering Data Spare Parts Bellows Suction Cups FSGAO (1.5 Folds)

Type	Spare Parts	Part no.
FSGAO 95x40 VU1-72 G1/8-AG	Bellows suction cup (oval)	FSGAO 95x40 VU1-72 N038 10.01.06.00499
FSGAO 140x65 VU1-72 G1/4-AG	Bellows suction cup (oval)	FSGAO 140x65 VU1-72 N039 10.01.06.00468



## Technical Data Bellows Suction Cups FSGAO (1.5 Folds)

Type	Suction force [N]*	Pull-off force [N]	Volume [cm <sup>3</sup> ]	Workpiece radius min. (convex) [mm]	Hose diameter (recom.) d [mm]**	Nipple family
FSGAO 95x40 VU1-72 G1/8-AG	95	110	39	20	9	N 038
FSGAO 140x65 VU1-72 G1/4-AG	225	255	114	30	9	N 039

\*The specified suction forces are theoretical values at a vacuum of -0.6 bar and with a smooth, dry workpiece surface - they do not include a safety factor

\*\*The recommended hose diameter refers to a hose length of approx. 2 m

# Bellows Suction Cups FSGAO (1.5 Folds)

Suction area (LxW) 95 x 40 mm and 140 x 65 mm

## Design Data Bellows Suction Cups FSGAO (1.5 Folds)

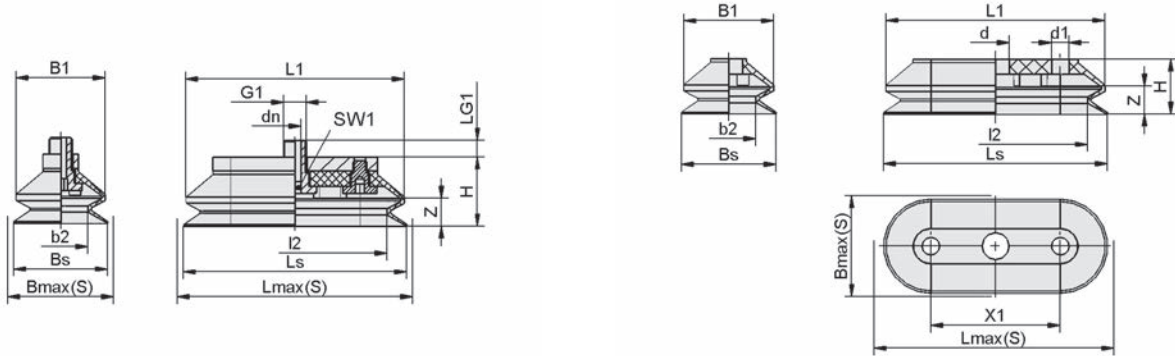

FSGAO VU1

FGAO VU1

Type*	b2 [mm]	B1 [mm]	Bmax(S) [mm]**	Bs [mm]	dn [mm]	G1	H [mm]	LG1 [mm]	I2 [mm]	L1 [mm]	Lmax(S) [mm]***	Ls [mm]	SW1 [mm]	Z (Stroke) [mm]
FSGAO 95x40 VU1-72 G1/8-AG	23	38	42.5	40	5	G1/8"-M	30	8	78	93	97	95	4	12
FSGAO 140x65 VU1-72 G1/4-AG	36	65	68.5	65	8	G1/4"-M	38	10	111	140	142	140	8	16

\*Acceptable dimensional tolerances for rubber parts concerning to DIN ISO 3302-1 M3  
 \*\*External dimension of the suction cup when it is pressed against the workpiece by the vacuum  
 \*\*\*External dimension of the suction cup when it is pressed against the workpiece by the vacuum

Type*	b2 [mm]	B1 [mm]	Bmax(S) [mm]**	Bs [mm]	d [mm]	d1 [mm]	H [mm]	L1 [mm]	I2 [mm]	Lmax(S) [mm]***	Ls [mm]	X1 [mm]	Z (Stroke) [mm]
FGAO 95x40 VU1-72 N038	23	38	43	40	11.5	7.5	23.5	93	78	97	95	55	12
FGAO 140x65 VU1-72 N039	36	65	69	65	15.5	9.5	30.0	140	111	142	140	75	16

\*Acceptable dimensional tolerances for rubber parts concerning to DIN ISO 3302-1 M3  
 \*\*External dimension of the suction cup when it is pressed against the workpiece by the vacuum  
 \*\*\*External dimension of the suction cup when it is pressed against the workpiece by the vacuum



# Bell-Shaped Suction Cups SAX

Suction area (Ø) from 30 mm to 115 mm

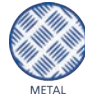

Bell-Shaped Suction Cups SAX

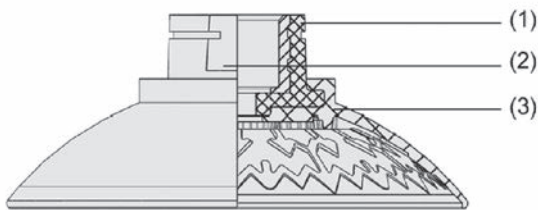

System Design Bell-Shaped Suction Cups SAX

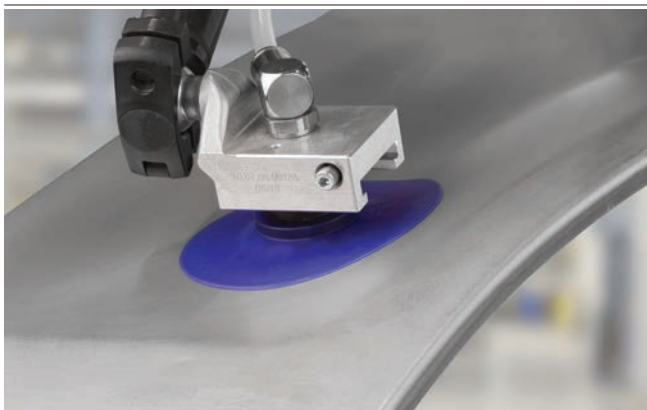

Bell-shaped suction cups SAX for handling formed sheet metal parts

## Suitability for Industry Specific Applications

### Applications

- Lightweight high-speed suction cups with demands for highest holding and shear forces for fast handling of sheet metal and car body parts
- Handling of workpieces with oily surfaces
- Loading and unloading CNC metal and laser cutting machines
- Handling of blanks at destackers
- Handling of workpieces with convex surfaces

### Design

- Lightweight, round bell-shaped suction cup with flexible sealing lip and optimal internal structure (3)
- Wear-resistant material Elastodur of suction cup (ED-85)
- Vulcanized connection nipple out of reinforced plastics (1) (very high strength)
- Key surface for easy and quick installation (2)
- Available as mounted suction cup with various connection types

### Our Highlights...

- Optimal internal structure and reduced height
- Lightweight design
- Significantly increased stroke of suction cup
- Flexible sealing lip

### Your Benefits...

- Highest transmission of holding forces and adaption of shear forces, especially on oily sheet metal
- Reduced weight of the tooling for high speed applications
- Very good adjustment to different workpiece outlines
- Very good sealing features even on rough workpiece surfaces

# Bell-Shaped Suction Cups SAX

Suction area (Ø) from 30 mm to 115 mm

## Designation Code Bell-Shaped Suction Cups SAX



### 1 - Abbreviated designation

Code	Version
SAX	Bell-shaped

### 2 - Suction area

Code	Diameter in mm
30...115	ø 30 to 115

### 3 - Material

Code	Material
ED-85	Elastodur

### 4 - Connection

Code	Connection
G1/4-AG	G1/4-AG (AG = male (M))
G1/4-IG	G1/4-IG (IG = female (F))
G3/8-AG	G3/8-AG
G3/8-IG	G3/8-IG
M10-AG	M10-AG
M16-AG	M16-AG
NPT3/8-IG	NPT3/8-IG
RA	Rectangular adapter

Suction cup SAX, available in various diameters, is delivered with connection nipple vulcanized to elastomer part.

## Ordering Data Bell-Shaped Suction Cups SAX

Type	Vacuum connection:								
		G1/4-AG	G1/4-IG	G3/8-AG	G3/8-IG	M10-AG	M16-AG	NPT3/8-IG	Rectangular adapter
SAX 30	10.01.19.00213	10.01.19.00179	10.01.19.00195	10.01.19.00146	10.01.19.00220	10.01.19.00229	10.01.19.00147	10.01.19.00172	
SAX 40	10.01.19.00214	10.01.19.00180	10.01.19.00196	10.01.19.00148	10.01.19.00221	10.01.19.00230	10.01.19.00149	10.01.19.00173	
SAX 50	10.01.19.00215	10.01.19.00181	10.01.19.00197	10.01.19.00150	10.01.19.00222	10.01.19.00231	10.01.19.00151	10.01.19.00174	
SAX 60	10.01.19.00216	10.01.19.00182	10.01.19.00198	10.01.19.00152	10.01.19.00223	10.01.19.00232	10.01.19.00153	10.01.19.00175	
SAX 80	10.01.19.00217	10.01.19.00183	10.01.19.00199	10.01.19.00141	10.01.19.00224	10.01.19.00233	10.01.19.00145	10.01.19.00176	
SAX 100	10.01.19.00218	10.01.19.00184	10.01.19.00200	10.01.19.00154	10.01.19.00225	10.01.19.00234	10.01.19.00155	10.01.19.00177	
SAX 115	10.01.19.00219	10.01.19.00185	10.01.19.00201	10.01.19.00156	10.01.19.00226	10.01.19.00235	10.01.19.00157	10.01.19.00178	

## Technical Data Bell-Shaped Suction Cups SAX

Type	Suction force [N]*	Lateral force [N]**	Lateral force oily surface [N]	Volume [cm <sup>3</sup> ]	Workpiece radius min. (convex) [mm]
SAX 30	39	38	41	3.2	18
SAX 40	69	49	71	8.5	25
SAX 50	109	74	110	15.2	25
SAX 60	154	107	155	25.2	30
SAX 80	270	192	269	51.0	33
SAX 100	412	284	414	96.0	40
SAX 115	549	390	584	142.0	50

\*The specified suction forces are theoretical values at a vacuum of -0.6 bar and with a smooth, dry workpiece surface - they do not include a safety factor

\*\*The specified lateral forces are values measured at a vacuum of -0.6 bar with a dry or oily, smooth, flat workpiece surface. Depending on the workpiece surface and its quality, the actual values may deviate from these values.

# Bell-Shaped Suction Cups SAX

Suction area ( $\varnothing$ ) from 30 mm to 115 mm



## Design Data Bell-Shaped Suction Cups SAX

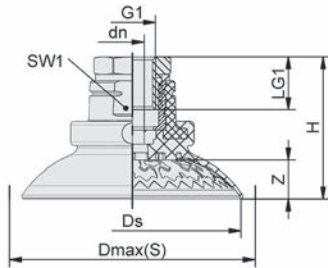

SAX G1/4-IG

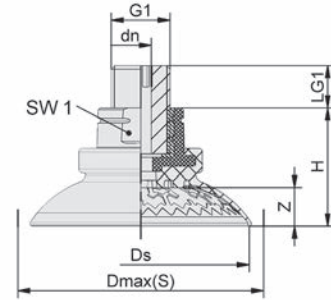

SAX AG

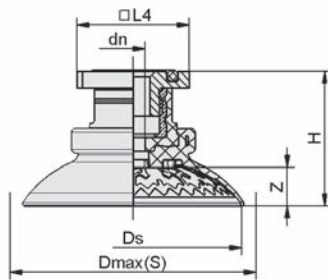

SAX RA

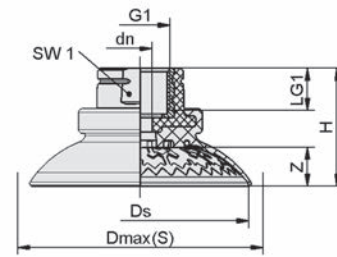

SAX G3/8-IG, NPT3/8-IG

Type*	dn [mm]	Dmax(S) [mm]**	Ds [mm]	G1	H [mm]	LG1 [mm]	L4 [mm]	SW1 [mm]	Z (Stroke) [mm]
SAX 30 ED-85 G1/4-AG	6.10	35.2	31.7	G1/4"-M	26.0	15	-	22	4.5
SAX 30 ED-85 G1/4-IG	6.75	35.2	31.7	G1/4"-F	32.8	15	-	22	4.5
SAX 30 ED-85 G3/8-AG	6.10	35.2	31.7	G3/8"-M	26.0	12	-	22	4.5
SAX 30 ED-85 G3/8-IG	6.75	35.2	31.7	G3/8"-F	26.0	12	-	22	4.5
SAX 30 ED-85 M10-AG	4.10	35.2	31.7	M10-M	26.0	15	-	22	4.5
SAX 30 ED-85 M16-AG	6.10	35.2	31.7	M16-M	26.0	12	-	22	4.5
SAX 30 ED-85 NPT3/8-IG	6.75	35.2	31.7	NPT3/8-F	26.0	12	-	22	4.5
SAX 30 ED-85 RA	6.75	35.2	31.7	-	30.7	-	31.8	22	4.5
SAX 40 ED-85 G1/4-AG	6.10	45.4	41.3	G1/4"-M	29.3	15	-	22	7.1
SAX 40 ED-85 G1/4-IG	6.75	45.4	41.3	G1/4"-F	36.1	15	-	22	7.1
SAX 40 ED-85 G3/8-AG	6.10	45.4	41.3	G3/8"-M	29.3	12	-	22	7.1
SAX 40 ED-85 G3/8-IG	6.75	45.4	41.3	G3/8"-F	29.3	12	-	22	7.1
SAX 40 ED-85 M10-AG	4.10	45.4	41.3	M10-M	29.3	15	-	22	7.1
SAX 40 ED-85 M16-AG	6.10	45.4	41.3	M16-M	29.3	12	-	22	7.1



# Bell-Shaped Suction Cups SAX

Suction area (Ø) from 30 mm to 115 mm



## Design Data Bell-Shaped Suction Cups SAX

Type*	dn [mm]	Dmax(S) [mm]**	Ds [mm]	G1	H [mm]	LG1 [mm]	L4 [mm]	SW1 [mm]	Z (Stroke) [mm]
SAX 40 ED-85 NPT3/8-IG	6.75	45.4	41.3	NPT3/8-F	29.3	12	-	22	7.1
SAX 40 ED-85 RA	6.75	45.4	41.3	-	34.0	-	31.8	22	7.1
SAX 50 ED-85 G1/4-AG	6.10	58.4	51.5	G1/4"-M	29.6	15	-	22	8.4
SAX 50 ED-85 G1/4-IG	6.75	58.4	51.5	G1/4"-F	36.4	15	-	22	8.4
SAX 50 ED-85 G3/8-AG	6.10	58.4	51.5	G3/8"-M	29.6	12	-	22	8.4
SAX 50 ED-85 G3/8-IG	6.75	58.4	51.5	G3/8"-F	29.6	12	-	22	8.4
SAX 50 ED-85 M10-AG	4.10	58.4	51.5	M10-M	29.6	15	-	22	8.4
SAX 50 ED-85 M16-AG	6.10	58.4	51.5	M16-M	29.6	12	-	22	8.4
SAX 50 ED-85 NPT3/8-IG	6.75	58.4	51.5	NPT3/8-F	29.6	12	-	22	8.4
SAX 50 ED-85 RA	6.75	58.4	51.5	-	34.3	-	31.8	22	8.4
SAX 60 ED-85 G1/4-AG	6.10	69.7	61.5	G1/4"-M	33.4	15	-	22	10.9
SAX 60 ED-85 G1/4-IG	6.75	69.7	61.5	G1/4"-F	40.2	15	-	22	10.9
SAX 60 ED-85 G3/8-AG	6.10	69.7	61.5	G3/8"-M	33.4	12	-	22	10.9
SAX 60 ED-85 G3/8-IG	6.75	69.7	61.5	G3/8"-F	33.4	12	-	22	10.9
SAX 60 ED-85 M10-AG	4.10	69.7	61.5	M10-M	33.4	15	-	22	10.9
SAX 60 ED-85 M16-AG	6.10	69.7	61.5	M16-M	33.4	12	-	22	10.9
SAX 60 ED-85 NPT3/8-IG	6.75	69.7	61.5	NPT3/8-F	33.4	12	-	22	10.9
SAX 60 ED-85 RA	6.75	69.7	61.5	-	38.1	-	31.8	22	10.9
SAX 80 ED-85 G1/4-AG	6.10	92.2	81.0	G1/4"-M	34.5	15	-	22	13.9
SAX 80 ED-85 G1/4-IG	6.75	92.2	81.0	G1/4"-F	41.3	15	-	22	13.9
SAX 80 ED-85 G3/8-AG	6.10	92.2	81.0	G3/8"-M	34.5	12	-	22	13.9
SAX 80 ED-85 G3/8-IG	6.75	92.2	81.0	G3/8"-F	34.5	12	-	22	13.9
SAX 80 ED-85 M10-AG	4.10	92.2	81.0	M10-M	34.5	15	-	22	13.9
SAX 80 ED-85 M16-AG	6.10	92.2	81.0	M16-M	34.5	12	-	22	13.9
SAX 80 ED-85 NPT3/8-IG	6.75	92.2	81.0	NPT3/8-F	34.5	12	-	22	13.9
SAX 80 ED-85 RA	6.75	92.2	81.0	-	39.2	-	31.8	22	13.9
SAX 100 ED-85 G1/4-AG	6.10	111.1	100.1	G1/4"-M	39.7	15	-	22	17.3
SAX 100 ED-85 G1/4-IG	6.75	111.1	100.1	G1/4"-F	46.5	15	-	22	17.3
SAX 100 ED-85 G3/8-AG	6.10	111.1	100.1	G3/8"-M	39.7	12	-	22	17.3
SAX 100 ED-85 G3/8-IG	6.75	111.1	100.1	G3/8"-F	39.7	12	-	22	17.3
SAX 100 ED-85 M10-AG	4.10	111.1	100.1	M10-M	39.7	15	-	22	17.3
SAX 100 ED-85 M16-AG	6.10	111.1	100.1	M16-M	39.7	12	-	22	17.3
SAX 100 ED-85 NPT3/8-IG	6.75	111.1	100.1	NPT3/8-F	39.7	12	-	22	17.3
SAX 100 ED-85 RA	6.75	111.1	100.1	-	44.4	-	31.8	22	17.3
SAX 115 ED-85 G1/4-AG	6.10	129.4	116.0	G1/4"-M	42.6	15	-	22	20.2
SAX 115 ED-85 G1/4-IG	6.75	129.4	116.0	G1/4"-F	49.4	15	-	22	20.2
SAX 115 ED-85 G3/8-AG	6.10	129.4	116.0	G3/8"-M	42.6	12	-	22	20.2
SAX 115 ED-85 G3/8-IG	6.75	129.4	116.0	G3/8"-F	42.6	12	-	22	20.2
SAX 115 ED-85 M10-AG	4.10	129.4	116.0	M10-M	42.6	15	-	22	20.2
SAX 115 ED-85 M16-AG	6.10	129.4	116.0	M16-M	42.6	12	-	22	20.2
SAX 115 ED-85 NPT3/8-IG	6.75	129.4	116.0	NPT3/8-F	42.6	12	-	22	20.2
SAX 115 ED-85 RA	6.75	129.4	116.0	-	47.3	-	31.8	22	20.2

\*Acceptable dimensional tolerances for rubber parts concerning to DIN ISO 3302-1 M3

\*\*External dimension of the suction cup when it is pressed against the workpiece by the vacuum

Schmalz –  
The Company

Vacuum  
Suction Cups

Special  
Grippers

Gripping  
Systems

Clamping  
Systems

Mounting  
Elements

Vacuum  
Generators

Valve  
Technology

Switches and  
Monitoring

Filters and  
Connections

Services

Contact

Glossary

Index of  
Products



# Bell-Shaped Suction Cups SAOXM (Oval)

Suction area (LxW) 60 x 20 mm to 100 x 40 mm

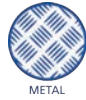

Bell-Shaped Suction Cups SAOXM (Oval)

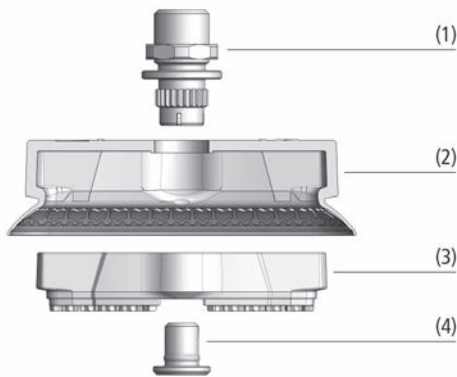

System Design Bell-Shaped Suction Cups SAOXM (Oval)



Suction cups SAOXM for handling formed sheet metal parts

## Suitability for Industry Specific Applications

### Applications

- Oval high-speed suction cup for applications with demands for highest holding forces and shear forces especially for narrow metal sheets and car body parts
- Handling of long workpieces, workpieces with internal ribbing and reinforcing plates
- Handling of workpieces with oily surfaces
- Loading and unloading CNC metal and laser cutting machines
- Handling of workpieces with convex surfaces

### Design

- Oval bell-shaped suction cup (2) with flexible sealing lip and optimum inner structure
- Wear-resistant material Elastodur of suction cup (ED-85) and friction disc (ED-65)
- Insert (3) with friction disc for reinforcing the suction cup
- Two-piece, reusable Schmalz Connector consisting of an upper part (1) and a lower part (4)
- Upper part of the connector with anti-rotation guard
- Lower part of the connector with anti-loosening guard

### Our Highlights...

- Very high suction cup stroke
- Optimized internal structure
- Large-surface, structured inner support

### Your Benefits...

- Optimum adjustability for different workpiece contours
- Extremely high absorption of holding and lateral forces, especially on oily sheet metal
- Avoiding of deep-drawing, even with thin sheets



# Bell-Shaped Suction Cups SAOXM (Oval)

Suction area (LxW) 60 x 20 mm to 100 x 40 mm

## Designation Code Bell-Shaped Suction Cups SAOXM (Oval)



### 1 – Abbreviated designation

Code	Version
SAOXM	Bell-shaped, oval

### 2 – Suction area

Code	LxW in mm
60x20...100x40	60x20 to 100x40

### 3 – Material

Code	Material
ED-85	Elastodur

### 4 – Connection

Code	Connection
G1/4-IG	G1/4-IG (IG = female (F))
G1/4-AG	G1/4-AG (AG = male (M))
G3/8-IG	G3/8-IG
G3/8-AG	G3/8-AG
M10-AG	M10-AG
M14x1.5-AG	M14x1.5-AG
NPT3/8-IG	NPT3/8-IG
RA	Rectangular adapter

Bell-shaped suction cup SAOXM (elastomer part with insert including friction disc + connection element) is delivered assembled.

The assembly consists of:

- Bell-shaped suction cup of type SAOXM – elastomer part, available in various dimensions
- Insert – including moulded friction disc
- Connector upper part – available with various threads
- Connector lower part

Available spare parts: suction cup SAOXM, Schmalz-Connector-Insert, Schmalz-Connector upper part (Schmalz-Connector-Adapter), Schmalz-Connector lower part (Schmalz-Connector-Screw)

## Ordering Data Bell-Shaped Suction Cups SAOXM (Oval)

Type		Vacuum connection:							Rectangular adapter
		G1/4-F	G1/4-M	G3/8-F	G3/8-M	M10-M	M14x1.5-M	NPT3/8-F	
SAOXM	60x20	10.01.24.00013	10.01.24.00033	10.01.24.00017	10.01.24.00036	10.01.24.00025	10.01.24.00029	10.01.24.00042	10.01.24.00021
SAOXM	80x30	10.01.24.00014	10.01.24.00034	10.01.24.00018	10.01.24.00037	10.01.24.00026	10.01.24.00030	10.01.24.00043	10.01.24.00022
SAOXM	100x40	10.01.24.00015	10.01.24.00035	10.01.24.00019	10.01.24.00038	10.01.24.00027	10.01.24.00031	10.01.24.00044	10.01.24.00023

## Ordering Data Spare Parts Bell-Shaped Suction Cups SAOXM (Oval)

Type	Spare Parts		Part no.
SAOXM 60x20	Bell suction cup (oval)	SAOXM 60x20 ED-85 SC045-AR	10.01.24.00001
SAOXM 80x30	Bell suction cup (oval)	SAOXM 80x30 ED-85 SC045-AR	10.01.24.00002
SAOXM 100x40	Bell suction cup (oval)	SAOXM 100x40 ED-85 SC055-AR	10.01.24.00003

Type	Spare Parts		Part no.
SAOXM 60x20	Schmalz-Connector-Insert	SC-I 045 AR-FDC	10.01.24.00009
SAOXM 80x30	Schmalz-Connector-Insert	SC-I 045 AR-FDC	10.01.24.00010
SAOXM 100x40	Schmalz-Connector-Insert	SC-I 055 AR-FDC	10.01.24.00011

# Bell-Shaped Suction Cups SAOXM (Oval)

Suction area (LxW) 60 x 20 mm to 100 x 40 mm



## Ordering Data Spare Parts Bell-Shaped Suction Cups SAOXM (Oval)

Type	Spare Parts		Part no.
SAOXM 60x20 ED-85 G1/4-IG	Schmalz-Connector-Adapter	SC-A 045-AR G1/4-IG L	10.01.06.03130
SAOXM 60x20 ED-85 G1/4-AG	Schmalz-Connector-Adapter	SC-A 045-AR G1/4-AG L	10.01.06.03131
SAOXM 60x20 ED-85 G3/8-IG	Schmalz-Connector-Adapter	SC-A 045-AR G3/8-IG L	10.01.06.03132
SAOXM 60x20 ED-85 G3/8-AG	Schmalz-Connector-Adapter	SC-A 045-AR G3/8-AG L	10.01.06.03133
SAOXM 60x20 ED-85 M10-AG	Schmalz-Connector-Adapter	SC-A 045-AR M10-AG L	10.01.06.03136
SAOXM 60x20 ED-85 M14x1.5-AG	Schmalz-Connector-Adapter	SC-A 045-AR M14x1.5-AG L	10.01.06.03137
SAOXM 60x20 ED-85 NPT3/8-IG	Schmalz-Connector-Adapter	SC-A 045-AR NPT3/8-IG L	10.01.06.03140
SAOXM 60x20 ED-85 RA	Schmalz-Connector-Adapter	SC-A 045-AR RA L	10.01.06.03135
SAOXM 80x30 ED-85 G1/4-IG	Schmalz-Connector-Adapter	SC-A 045-AR G1/4-IG L	10.01.06.03130
SAOXM 80x30 ED-85 G1/4-AG	Schmalz-Connector-Adapter	SC-A 045-AR G1/4-AG L	10.01.06.03131
SAOXM 80x30 ED-85 G3/8-IG	Schmalz-Connector-Adapter	SC-A 045-AR G3/8-IG L	10.01.06.03132
SAOXM 80x30 ED-85 G3/8-AG	Schmalz-Connector-Adapter	SC-A 045-AR G3/8-AG L	10.01.06.03133
SAOXM 80x30 ED-85 M10-AG	Schmalz-Connector-Adapter	SC-A 045-AR M10-AG L	10.01.06.03136
SAOXM 80x30 ED-85 M14x1.5-AG	Schmalz-Connector-Adapter	SC-A 045-AR M14x1.5-AG L	10.01.06.03137
SAOXM 80x30 ED-85 NPT3/8-IG	Schmalz-Connector-Adapter	SC-A 045-AR NPT3/8-IG L	10.01.06.03140
SAOXM 80x30 ED-85 RA	Schmalz-Connector-Adapter	SC-A 045-AR RA L	10.01.06.03135
SAOXM 100x40 ED-85 G1/4-IG	Schmalz-Connector-Adapter	SC-A 055-AR G1/4-IG L	10.01.06.03164
SAOXM 100x40 ED-85 G1/4-AG	Schmalz-Connector-Adapter	SC-A 055-AR G1/4-AG L	10.01.06.03165
SAOXM 100x40 ED-85 G3/8-IG	Schmalz-Connector-Adapter	SC-A 055-AR G3/8-IG L	10.01.06.03166
SAOXM 100x40 ED-85 G3/8-AG	Schmalz-Connector-Adapter	SC-A 055-AR G3/8-AG L	10.01.06.03167
SAOXM 100x40 ED-85 M10-AG	Schmalz-Connector-Adapter	SC-A 055-AR M10-AG L	10.01.06.03170
SAOXM 100x40 ED-85 M14x1.5-AG	Schmalz-Connector-Adapter	SC-A 055-AR M14x1.5-AG L	10.01.06.03171
SAOXM 100x40 ED-85 NPT3/8-IG	Schmalz-Connector-Adapter	SC-A 055-AR NPT3/8-IG L	10.01.06.03174
SAOXM 100x40 ED-85 RA	Schmalz-Connector-Adapter	SC-A 055-AR RA L	10.01.06.03169

Type	Spare Parts		Part no.
SAOXM 60x20	Schmalz-Connector-Screw	SC-S 045 L	10.01.06.02740
SAOXM 80x30	Schmalz-Connector-Screw	SC-S 045 L	10.01.06.02740
SAOXM 100x40	Schmalz-Connector-Screw	SC-S 055 L	10.01.06.02746



## Technical Data Bell-Shaped Suction Cups SAOXM (Oval)

Type	Suction force [N]*	Lateral force [N]**	Lateral force oily surface [N]	Volume [cm³]	Workpiece radius min. (convex) [mm]	Hose diameter (recom.) d [mm]***
SAOXM 60x20	56	44	62	5	10	4
SAOXM 80x30	105	110	134	13	20	4
SAOXM 100x40	173	135	156	24	32	6

\*The specified suction forces are theoretical values at a vacuum of -0.6 bar and with a smooth, dry workpiece surface - they do not include a safety factor

\*\*The specified lateral forces are values measured at a vacuum of -0.6 bar with a dry, smooth, flat workpiece surface. Depending on the workpiece surface and its quality, the actual values may deviate from these values.

\*\*\*The recommended hose diameter refers to a hose length of approx. 2 m



# Bell-Shaped Suction Cups SAOXM (Oval)

Suction area (LxW) 60 x 20 mm to 100 x 40 mm

## Design Data Bell-Shaped Suction Cups SAOXM (Oval)

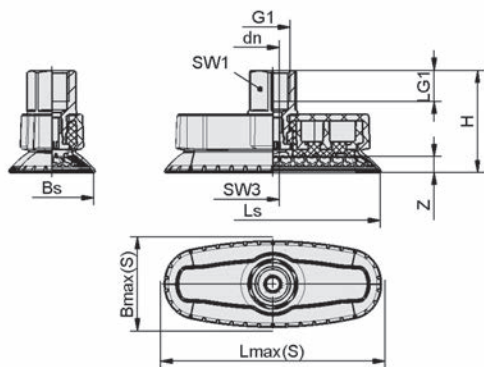

SAOXM IG

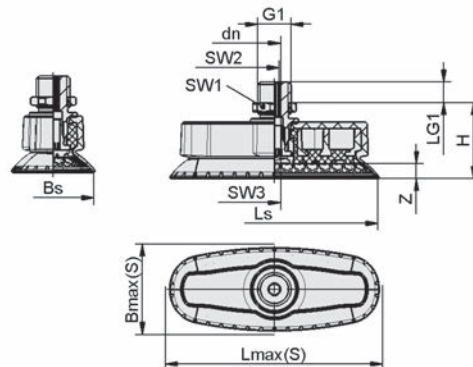

SAOXM AG

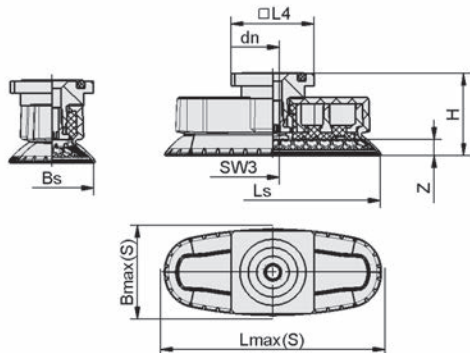

SAOXM RA

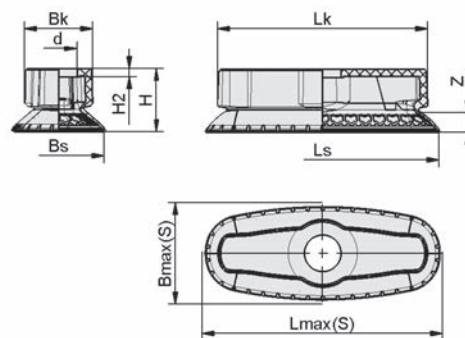

SAOXM

Type*	Bmax(S) [mm]**	Bs [mm]	dn [mm]	G1	H [mm]	LG1 [mm]	Lmax(S) [mm]***	Ls [mm]	L4 [mm]	SW1 [mm]	SW2 [mm]	SW3 [mm]	Z (Stroke) [mm]
SAOXM 60x20 ED-85 G1/4-IG	24.0	19	5.1	G1/4"-F	38.5	12	67	62	-	17	-	5	5
SAOXM 60x20 ED-85 G1/4-AG	24.0	19	4.1	G1/4"-M	29.8	8	67	62	-	17	4	5	5
SAOXM 60x20 ED-85 G3/8-IG	24.0	19	5.1	G3/8"-F	38.5	12	67	62	-	22	-	5	5
SAOXM 60x20 ED-85 G3/8-AG	24.0	19	4.1	G3/8"-M	29.8	8	67	62	-	19	4	5	5
SAOXM 60x20 ED-85 M10-AG	24.0	19	4.1	M10-M	31.3	8	67	62	-	16	4	5	5
SAOXM 60x20 ED-85 M14x1.5-AG	24.0	19	4.1	M14x1.5-M	31.3	8	67	62	-	22	4	5	5
SAOXM 60x20 ED-85 NPT3/8-IG	24.0	19	5.1	NPT3/8-F	38.5	14	67	62	-	22	-	5	5
SAOXM 60x20 ED-85 RA	24.0	19	5.1	-	30.8	-	67	62	32	-	-	5	5
SAOXM 80x30 ED-85 G1/4-IG	41.5	32	5.1	G1/4"-F	39.1	12	88	83	-	17	-	5	6
SAOXM 80x30 ED-85 G1/4-AG	41.5	32	4.1	G1/4"-M	30.3	8	88	83	-	17	4	5	6
SAOXM 80x30 ED-85 G3/8-IG	41.5	32	5.1	G3/8"-F	39.1	12	88	83	-	22	-	5	6
SAOXM 80x30 ED-85 G3/8-AG	41.5	32	4.1	G3/8"-M	30.3	8	88	83	-	19	4	5	6
SAOXM 80x30 ED-85 M10-AG	41.5	32	4.1	M10-M	31.8	8	88	83	-	16	4	5	6



# Bell-Shaped Suction Cups SAOXM (Oval)

Suction area (LxW) 60 x 20 mm to 100 x 40 mm



## Design Data Bell-Shaped Suction Cups SAOXM (Oval)

Type*	Bmax(S) [mm]**	Bs [mm]	dn [mm]	G1	H [mm]	LG1 [mm]	Lmax(S) [mm]***	Ls [mm]	L4 [mm]	SW1 [mm]	SW2 [mm]	SW3 [mm]	Z (Stroke) [mm]
SAOXM 80x30 ED-85 M14x1.5-AG	41.5	32	4.1	M14x1.5-M	31.8	8	88	83	-	22	4	5	6
SAOXM 80x30 ED-85 NPT3/8-IG	41.5	32	5.1	NPT3/8-F	39.1	14	88	83	-	22	-	5	6
SAOXM 80x30 ED-85 RA	41.5	32	5.1	-	31.4	-	88	83	32	-	-	5	6
SAOXM 100x40 ED-85 G1/4-IG	51.0	42	6.1	G1/4"-F	45.7	12	109	102	-	17	-	6	8
SAOXM 100x40 ED-85 G1/4-AG	51.0	42	5.1	G1/4"-M	37.7	8	109	102	-	17	5	6	8
SAOXM 100x40 ED-85 G3/8-IG	51.0	42	6.1	G3/8"-F	45.7	12	109	102	-	22	-	6	8
SAOXM 100x40 ED-85 G3/8-AG	51.0	42	5.1	G3/8"-M	37.7	8	109	102	-	19	5	6	8
SAOXM 100x40 ED-85 M10-AG	51.0	42	4.1	M10-M	37.7	8	109	102	-	16	4	6	8
SAOXM 100x40 ED-85 M14x1.5-AG	51.0	42	5.1	M14x1.5-M	39.2	8	109	102	-	22	5	6	8
SAOXM 100x40 ED-85 NPT3/8-IG	51.0	42	6.1	NPT3/8-F	45.7	15	109	102	-	22	-	6	8
SAOXM 100x40 ED-85 RA	51.0	42	6.1	-	38.2	-	109	102	32	-	-	6	8

\*Acceptable dimensional tolerances for rubber parts concerning to DIN ISO 3302-1 M3

\*\*External dimension of the suction cup when it is pressed against the workpiece by the vacuum

\*\*\*External dimension of the suction cup when it is pressed against the workpiece by the vacuum

Type*	Bk [mm]	Bmax(S) [mm]**	Bs [mm]	d [mm]	H [mm]	H2 [mm]	Lk [mm]	Lmax(S) [mm]***	Ls [mm]	Z (Stroke) [mm]
SAOXM 60x20 ED-85 SC045-AR	20.0	24.0	18.7	12.8	21.9	3	60.0	67	61.8	5
SAOXM 80x30 ED-85 SC045-AR	24.1	41.5	31.9	12.8	22.4	3	74.3	88	82.1	6
SAOXM 100x40 ED-85 SC055-AR	32.3	51.0	41.6	15.2	29.3	4	89.9	109	101.8	8

\*Acceptable dimensional tolerances for rubber parts concerning to DIN ISO 3302-1 M3

\*\*External dimension of the suction cup when it is pressed against the workpiece by the vacuum

\*\*\*External dimension of the suction cup when it is pressed against the workpiece by the vacuum

# Flat Suction Cups SAF

Suction area (Ø) from 30 mm to 125 mm

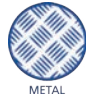

## Suitability for Industry Specific Applications

### Applications

- Round, flat suction cup for dynamic handling of metal sheets with very short cycle times
- Handling of thin steel sheets and aluminum sheets without deformation
- For use in feeder systems for press lines in the automotive industry
- Special groove on the bottom prevents oily sheets from slipping, permitting precise positioning in stamping presses etc.



Flat Suction Cups SAF

### Design

- Robust and wear-resistant suction cup SAF made of NBR with single sealing lip, special groove and inner support
- Suction cup SAF vulcanized to the connection nipple (very high strength)
- Suction cup available with various connection types
- Available in two material hardness values (45 Shore, 60 Shore)

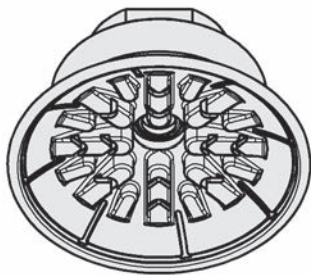

System Design Flat Suction Cups SAF

### Our Highlights...

- Wide range of diameters
- Large-area structured inner support
- Soft and flexible sealing lip
- Various material hardness values

### Your Benefits...

- For a wide range of workpiece sizes and shapes
- No deep-drawing of the workpiece; capable of handling high lateral forces, even on oily metal sheets
- Excellent sealing, even on slightly curved surfaces
- Optimum adaptation to varying workpieces



Flat suction cups SAF being used for handling sheet metal parts

Schmalz – The Company

Vacuum Suction Cups

Special Grippers

Gripping Systems

Clamping Systems

Mounting Elements

Vacuum Generators

Valve Technology

Switches and Monitoring

Filters and Connections

Services

Contact

Glossary

Index of Products



# Flat Suction Cups SAF

Suction area (Ø) from 30 mm to 125 mm



## Designation Code Flat Suction Cups SAF



### 1 – Abbreviated designation

Code	Version
SAF	Flat

### 2 – Suction area

Code	Diameter in mm
30...125	ø 30 to 125

### 3 – Material

Code	Material
NBR-45	Nitrile caoutchuc
NBR-60	Nitrile caoutchuc

### 4 – Connection

Code	Connection
G1/4-AG	G1/4-AG (AG = male (M))
G1/4-IG	G1/4-IG (IG = female (F))
G3/8-IG	G3/8-IG
M10-AG	M10-AG
M14x1.5-AG	M14x1.5-AG
RA	Rectangular adapter

Suction cup SAF, available in various diameters, is delivered with connection nipple vulcanized to elastomer part.



## Ordering Data Flat Suction Cups SAF

Type				Vacuum connection:					
				G1/4-M	G1/4-F	G3/8-F	M10-M	M14x1.5-M	Rectangular adapter
SAF 30	NBR	45		10.01.01.11421	10.01.01.11400	10.01.01.11420	10.01.01.11425	10.01.01.11426	10.01.01.11423
SAF 30	NBR	60		10.01.01.10646	10.01.01.10506	10.01.01.10705	10.01.01.10713	10.01.01.10730	10.01.01.10790
SAF 40	NBR	45		10.01.01.11430	10.01.01.11401	10.01.01.11431	10.01.01.11435	10.01.01.11436	10.01.01.11433
SAF 40	NBR	60		10.01.01.10647	10.01.01.10508	10.01.01.10708	10.01.01.10716	10.01.01.10733	10.01.01.10793
SAF 50	NBR	45		10.01.01.11440	10.01.01.11441	10.01.01.11402	10.01.01.11444	10.01.01.11445	10.01.01.11442
SAF 50	NBR	60		10.01.01.10635	10.01.01.10688	10.01.01.10510	10.01.01.10719	10.01.01.10736	10.01.01.10796
SAF 60	NBR	45		10.01.01.11450	10.01.01.11451	10.01.01.11403	10.01.01.11454	10.01.01.11455	10.01.01.11452
SAF 60	NBR	60		10.01.01.10622	10.01.01.10689	10.01.01.10512	10.01.01.10721	10.01.01.10739	10.01.01.10799
SAF 80	NBR	45		10.01.01.11460	10.01.01.11461	10.01.01.11404	10.01.01.11466	10.01.01.11467	10.01.01.11464
SAF 80	NBR	60		10.01.01.10623	10.01.01.10690	10.01.01.10514	10.01.01.10724	10.01.01.10742	10.01.01.10802
SAF 100	NBR	45		10.01.01.11470	10.01.01.11471	10.01.01.11405	10.01.01.11476	10.01.01.11477	10.01.01.11474
SAF 100	NBR	60		10.01.01.10624	10.01.01.10691	10.01.01.10516	10.01.01.10726	10.01.01.10745	10.01.01.10805
SAF 125	NBR	45		10.01.01.11480	10.01.01.11481	10.01.01.11406	10.01.01.11485	10.01.01.11486	10.01.01.11483
SAF 125	NBR	60		10.01.01.10666	10.01.01.10692	10.01.01.10518	10.01.01.10728	10.01.01.10748	10.01.01.10808



Schmalz – The Company  
Vacuum Suction Cups  
Special Grippers  
Gripping Systems  
Clamping Systems  
Mounting Elements  
Vacuum Generators  
Valve Technology  
Switches and Monitoring  
Filters and Connections  
Services  
Contact  
Glossary  
Index of Products

# Flat Suction Cups SAF

Suction area (Ø) from 30 mm to 125 mm



## Technical Data Flat Suction Cups SAF

Type	Suction force [N]*	Lateral force [N]**	Lateral force oily surface [N]	Volume [cm³]	Workpiece radius min. (convex) [mm]	Hose diameter (recom.) d [mm]***
SAF 30	38	30	28	2.8	40	4
SAF 40	69	52	50	5.3	50	4
SAF 50	100	80	76	9.5	65	4
SAF 60	150	105	85	16.7	75	6
SAF 80	272	205	180	36.7	100	6
SAF 100	430	310	300	59.9	135	6
SAF 125	660	475	400	119.0	165	9

\*The specified suction forces are theoretical values at a vacuum of -0.6 bar and with a smooth, dry workpiece surface - they do not include a safety factor

\*\*The specified lateral forces are values measured at a vacuum of -0.6 bar with a dry or oily, smooth, flat workpiece surface. Depending on the workpiece surface and its quality, the actual values may deviate from these values.

\*\*\*The recommended hose diameter refers to a hose length of approx. 2 m



## Design Data Flat Suction Cups SAF

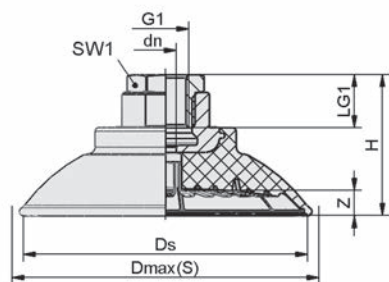

SAF IG

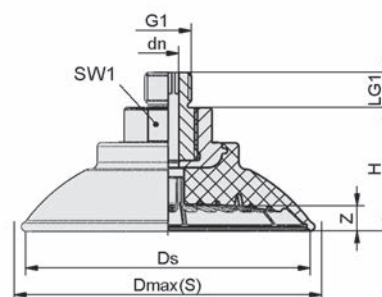

SAF AG

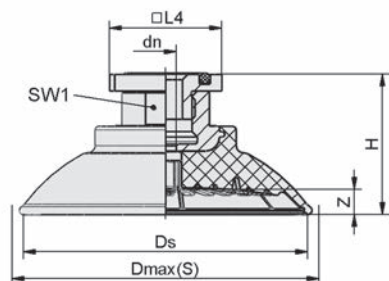

SAF RA



Schmalz - The Company  
 Vacuum Suction Cups  
 Special Grippers  
 Gripping Systems  
 Clamping Systems  
 Mounting Elements  
 Vacuum Generators  
 Valve Technology  
 Switches and Monitoring  
 Filters and Connections  
 Services  
 Contact  
 Glossary  
 Index of Products

# Flat Suction Cups SAF

Suction area (Ø) from 30 mm to 125 mm



## Design Data Flat Suction Cups SAF

Type*			Dmax(S) [mm]**	dn [mm]	Ds [mm]	G1	H [mm]	LG1 [mm]	L4 [mm]	SW1 [mm]	Z (Stroke) [mm]
SAF	30	G1/4-AG	34	4	31	G1/4"-M	20.0	10	-	17	3.0
SAF	30	G1/4-IG	34	4	31	G1/4"-F	20.0	12	-	17	3.0
SAF	30	G3/8-IG	34	4	31	G3/8"-F	36.0	9	-	22	3.0
SAF	30	M10-AG	34	4	31	M10-M	20.0	12	-	17	3.0
SAF	30	M14x1.5-AG	34	4	31	M14x1.5-M	20.0	12	-	17	3.0
SAF	30	RA	34	4	31	-	23.2	-	32	17	3.0
SAF	40	G1/4-AG	46	4	41	G1/4"-M	22.0	10	-	17	4.0
SAF	40	G1/4-IG	46	4	41	G1/4"-F	22.0	12	-	17	4.0
SAF	40	G3/8-IG	46	4	41	G3/8"-F	38.0	9	-	22	4.0
SAF	40	M10-AG	46	4	41	M10-M	22.0	12	-	17	4.0
SAF	40	M14x1.5-AG	46	4	41	M14x1.5-M	22.0	12	-	17	4.0
SAF	40	RA	46	4	41	-	25.0	-	32	17	4.0
SAF	50	G1/4-AG	56	6	50	G1/4"-M	28.0	10	-	22	5.0
SAF	50	G1/4-IG	56	6	50	G1/4"-F	33.0	15	-	22	5.0
SAF	50	G3/8-IG	56	6	50	G3/8"-F	28.0	15	-	22	5.0
SAF	50	M10-AG	56	4	50	M10-M	28.0	12	-	22	5.0
SAF	50	M14x1.5-AG	56	6	50	M14x1.5-M	28.0	12	-	22	5.0
SAF	50	RA	56	6	50	-	27.5	-	32	22	5.0
SAF	60	G1/4-AG	67	6	61	G1/4"-M	31.0	10	-	22	6.0
SAF	60	G1/4-IG	67	6	61	G1/4"-F	36.0	15	-	22	6.0
SAF	60	G3/8-IG	67	6	61	G3/8"-F	31.0	15	-	22	6.0
SAF	60	M10-AG	67	4	61	M10-M	31.0	12	-	22	6.0
SAF	60	M14x1.5-AG	67	6	61	M14x1.5-M	31.0	12	-	22	6.0
SAF	60	RA	67	6	61	-	30.5	-	32	22	6.0
SAF	80	G1/4-AG	89	6	83	G1/4"-M	35.0	10	-	22	7.6
SAF	80	G1/4-IG	89	6	83	G1/4"-F	40.0	20	-	22	7.6
SAF	80	G3/8-IG	89	6	83	G3/8"-F	35.0	15	-	22	7.6
SAF	80	M10-AG	89	4	83	M10-M	35.0	12	-	22	7.6
SAF	80	M14x1.5-AG	89	6	83	M14x1.5-M	35.0	12	-	22	7.6
SAF	80	RA	89	6	83	-	34.5	-	32	22	7.6
SAF	100	G1/4-AG	110	6	103	G1/4"-M	36.0	10	-	22	9.5
SAF	100	G1/4-IG	110	6	103	G1/4"-F	41.0	20	-	22	9.5
SAF	100	G3/8-IG	110	6	103	G3/8"-F	36.0	15	-	22	9.5
SAF	100	M10-AG	110	4	103	M10-M	36.0	12	-	22	9.5
SAF	100	M14x1.5-AG	110	6	103	M14x1.5-M	36.0	12	-	22	9.5
SAF	100	RA	110	6	103	-	35.5	-	32	22	9.5
SAF	125	G1/4-AG	135	6	125	G1/4"-M	43.0	10	-	22	12.5
SAF	125	G1/4-IG	135	6	125	G1/4"-F	48.0	20	-	22	12.5
SAF	125	G3/8-IG	135	9	125	G3/8"-F	43.0	15	-	22	12.5
SAF	125	M10-AG	135	4	125	M10-M	43.0	12	-	22	12.5
SAF	125	M14x1.5-AG	135	6	125	M14x1.5-M	43.0	12	-	22	12.5
SAF	125	RA	135	9	125	-	42.5	-	32	22	12.5

\*Acceptable dimensional tolerances for rubber parts concerning to DIN ISO 3302-1 M3

\*\*External dimension of the suction cup when it is pressed against the workpiece by the vacuum

# Bellows Suction Cups SAB (1.5 Folds)

Suction area (Ø) from 22 mm to 125 mm



## Suitability for Industry Specific Applications

### Applications

- Round, bellows suction cup with 1.5 folds for dynamic handling of metal sheets (short cycle times)
- Handling of thin steel sheets and aluminum sheets without deformation
- Handling of pre-shaped metal sheet parts, since bellows shape permits optimum adaptation
- For use e.g. in feeder systems for press lines in the automotive industry
- Special groove on the bottom of the cup prevents the oily metal sheets from slipping and permits precise positioning in punching presses etc.



Bellows Suction Cups SAB (1.5 Folds)

### Design

- Robust and wear-resistant suction cup SAB with 1.5 folds, made of NBR, special groove and inner support
- Suction cup SAB vulcanized to the connection nipple (very high strength)
- Suction cups available with various connection types

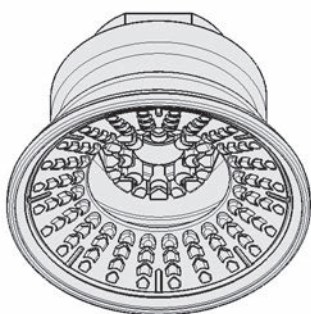

System Design Bellows Suction Cups SAB (1.5 Folds)



Bellows suction cups SAB being used for handling car bodywork parts

### Our Highlights...

- 1.5 folds
- Large, structured inner support
- Stiff top fold

### Your Benefits...

- Optimum adaptation and sealing to curved workpieces, very good damping during placement on workpiece
- No deep-drawing of the workpiece; capable of handling high lateral forces
- Good resistance to horizontal forces and lateral acceleration



Schmalz – The Company

Vacuum Suction Cups

Special Grippers

Gripping Systems

Clamping Systems

Mounting Elements

Vacuum Generators

Valve Technology

Switches and Monitoring

Filters and Connections

Services

Contact

Glossary

Index of Products

# Bellows Suction Cups SAB (1.5 Folds)

Suction area (Ø) from 22 mm to 125 mm



## Designation Code Bellows Suction Cups SAB (1.5 Folds)

<b>SAB</b>	-	<b>30</b>	-	<b>NBR-60</b>	-	<b>G1/4-AG</b>
<b>1</b>		<b>2</b>		<b>3</b>		<b>4</b>

### 1 – Abbreviated designation

Code	Version
SAB	1.5 folds

### 2 – Suction area

Code	Diameter in mm
22...125	ø 22 to 125

### 3 – Material

Code	Material
NBR-60	Nitrile caoutchuc

### 4 – Connection

Code	Connection
G1/4-AG	G1/4-AG (AG = male (M))
G1/4-IG	G1/4-IG (IG = female (F))
G3/8-IG	G3/8-IG
M10-AG	M10-AG
M14x1.5-AG	M14x1.5-AG
RA	Rectangular adapter

Suction cup SAB, available in various diameters, is delivered with connection nipple vulcanized to elastomer part.



## Ordering Data Bellows Suction Cups SAB (1.5 Folds)

Type*	Vacuum connection:						
	G1/4-F	G1/4-M	G3/8-F	M10-M	M14x1.5-M	Rectangular adapter	
SAB 22	10.01.06.01533	10.01.06.01653	10.01.06.01650	10.01.06.01654	10.01.06.01655	10.01.06.01663	
SAB 30	10.01.06.01196	10.01.06.01197	10.01.06.01198	10.01.06.01200	10.01.06.01201	10.01.06.01203	
SAB 40	10.01.06.00670	10.01.06.00803	10.01.06.00924	10.01.06.00994	10.01.06.01006	10.01.06.01054	
SAB 50	10.01.06.00851	10.01.06.00804	10.01.06.00672	10.01.06.00996	10.01.06.01008	10.01.06.01055	
SAB 60	10.01.06.00852	10.01.06.00805	10.01.06.00674	10.01.06.00998	10.01.06.01010	10.01.06.01056	
SAB 80	10.01.06.00850	10.01.06.00806	10.01.06.00676	10.01.06.01000	10.01.06.01012	10.01.06.01057	
SAB 100	10.01.06.00853	10.01.06.00807	10.01.06.00678	10.01.06.01002	10.01.06.01014	10.01.06.01058	
SAB 125	10.01.06.00854	10.01.06.00825	10.01.06.00680	10.01.06.01004	10.01.06.01016	10.01.06.01059	

\*Additional material specifications at beginning of the section "Vacuum Suction Cups"



## Technical Data Bellows Suction Cups SAB (1.5 Folds)

Type	Suction force [N]*	Pull-off force [N]	Lateral force [N]**	Lateral force oily surface [N]	Volume [cm³]	Workpiece radius min. (convex) [mm]	Hose diameter (recom.) d [mm]***
SAB 22	16	24	18	6	2.5	20	4
SAB 30	22	33	30	13	5.8	40	4
SAB 40	38	59	36	33	8.7	40	4
SAB 50	53	87	55	52	16.1	50	4
SAB 60	82	130	82	77	28.8	65	6
SAB 80	135	221	145	140	67.6	75	6
SAB 100	190	357	220	214	115.0	90	6
SAB 125	250	558	352	335	220.0	140	9

\*The specified suction forces are theoretical values at a vacuum of -0.6 bar and with a smooth, dry workpiece surface - they do not include a safety factor

\*\*The specified lateral forces are values measured at a vacuum of -0.6 bar with a dry or oily, smooth, flat workpiece surface. Depending on the workpiece surface and its quality, the actual values may deviate from these values.

\*\*\*The recommended hose diameter refers to a hose length of approx. 2 m



# Bellows Suction Cups SAB (1.5 Folds)

Suction area (Ø) from 22 mm to 125 mm

**Design Data Bellows Suction Cups SAB (1.5 Folds)**

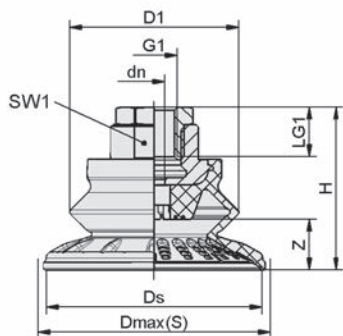

SAB IG

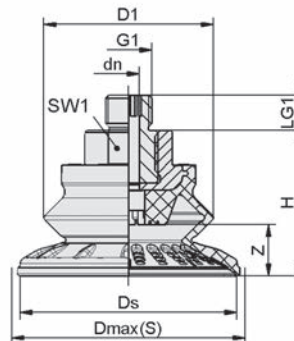

SAB AG

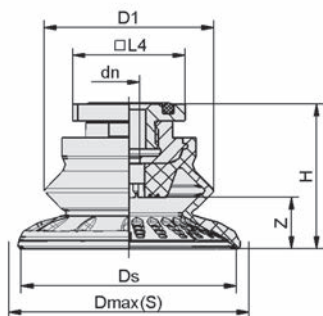

SAB RA

Type*	D1 [mm]	Dmax(S) [mm]**	dn [mm]	Ds [mm]	G1	H [mm]	LG1 [mm]	L4 [mm]	SW1 [mm]	Z (Stroke) [mm]
SAB 22 NBR-60 G1/4-AG	22	24	3.5	20.6	G1/4"-M	25.0	10	-	16	5.8
SAB 22 NBR-60 G1/4-IG	22	24	3.5	20.6	G1/4"-F	25.0	12	-	16	5.8
SAB 22 NBR-60 G3/8-IG	22	24	3.5	20.6	G3/8"-F	41.0	10	-	22	5.8
SAB 22 NBR-60 M10-AG	22	24	3.5	20.6	M10-M	25.0	12	-	16	5.8
SAB 22 NBR-60 M14x1.5-AG	22	24	3.5	20.6	M14x1.5-M	25.0	12	-	16	5.8
SAB 22 NBR-60 RA	22	24	3.5	20.6	-	28.2	-	32	-	5.8
SAB 30 NBR-60 G1/4-AG	32	34	4.0	30.6	G1/4"-M	28.0	10	-	17	9.0
SAB 30 NBR-60 G1/4-IG	32	34	4.0	30.6	G1/4"-F	28.0	12	-	17	9.0
SAB 30 NBR-60 G3/8-IG	32	34	4.0	30.6	G3/8"-F	44.0	10	-	22	9.0
SAB 30 NBR-60 M10-AG	32	34	4.0	30.6	M10-M	28.0	12	-	17	9.0
SAB 30 NBR-60 M14x1.5-AG	32	34	4.0	30.6	M14x1.5-M	28.0	12	-	17	9.0
SAB 30 NBR-60 RA	32	34	4.0	30.6	-	31.2	-	32	-	9.0
SAB 40 NBR-60 G1/4-AG	32	45	4.0	40.1	G1/4"-M	28.8	10	-	17	10.0
SAB 40 NBR-60 G1/4-IG	32	45	4.0	40.1	G1/4"-F	28.8	12	-	17	10.0
SAB 40 NBR-60 G3/8-IG	32	45	4.0	40.1	G3/8"-F	44.8	10	-	22	10.0
SAB 40 NBR-60 M10-AG	32	45	4.0	40.1	M10-M	28.8	12	-	17	10.0



# Bellows Suction Cups SAB (1.5 Folds)

Suction area (Ø) from 22 mm to 125 mm



## Design Data Bellows Suction Cups SAB (1.5 Folds)

Type*	D1 [mm]	Dmax(S) [mm]**	dn [mm]	Ds [mm]	G1	H [mm]	LG1 [mm]	L4 [mm]	SW1 [mm]	Z (Stroke) [mm]
SAB 40 NBR-60 M14x1.5-AG	32	45	4.0	40.1	M14x1.5-M	28.8	12	-	17	10.0
SAB 40 NBR-60 RA	32	45	4.0	40.1	-	31.2	-	32	-	10.0
SAB 50 NBR-60 G1/4-AG	40	56	6.0	50.1	G1/4"-M	36.9	10	-	22	11.5
SAB 50 NBR-60 G1/4-IG	40	56	6.0	50.1	G1/4"-F	42.0	20	-	22	11.5
SAB 50 NBR-60 G3/8-IG	40	56	6.0	50.1	G3/8"-F	36.9	15	-	22	11.5
SAB 50 NBR-60 M10-AG	40	56	4.0	50.1	M10-M	36.9	12	-	22	11.5
SAB 50 NBR-60 M14x1.5-AG	40	56	6.0	50.1	M14x1.5-M	36.9	12	-	22	11.5
SAB 50 NBR-60 RA	40	56	6.0	50.1	-	36.6	-	32	-	11.5
SAB 60 NBR-60 G1/4-AG	48	67	6.0	61.1	G1/4"-M	41.3	10	-	22	14.5
SAB 60 NBR-60 G1/4-IG	48	67	6.0	61.1	G1/4"-F	46.3	20	-	22	14.5
SAB 60 NBR-60 G3/8-IG	48	67	6.0	61.1	G3/8"-F	41.3	15	-	22	14.5
SAB 60 NBR-60 M10-AG	48	67	4.0	61.1	M10-M	41.3	12	-	22	14.5
SAB 60 NBR-60 M14x1.5-AG	48	67	6.0	61.1	M14x1.5-M	41.3	12	-	22	14.5
SAB 60 NBR-60 RA	48	67	6.0	61.1	-	41.0	-	32	-	14.5
SAB 80 NBR-60 G1/4-AG	64	89	6.0	81.1	G1/4"-M	49.9	10	-	22	22.1
SAB 80 NBR-60 G1/4-IG	64	89	6.0	81.1	G1/4"-F	54.9	20	-	22	22.1
SAB 80 NBR-60 G3/8-IG	64	89	6.0	81.1	G3/8"-F	49.9	15	-	22	22.1
SAB 80 NBR-60 M10-AG	64	89	4.0	81.1	M10-M	49.9	12	-	22	22.1
SAB 80 NBR-60 M14x1.5-AG	64	89	6.0	81.1	M14x1.5-M	49.9	12	-	22	22.1
SAB 80 NBR-60 RA	64	89	6.0	81.1	-	49.6	-	32	-	22.1
SAB 100 NBR-60 G1/4-AG	77	110	6.0	100.8	G1/4"-M	56.6	10	-	22	25.8
SAB 100 NBR-60 G1/4-IG	77	110	6.0	100.8	G1/4"-F	61.8	20	-	22	25.8
SAB 100 NBR-60 G3/8-IG	77	110	6.0	100.8	G3/8"-F	56.6	15	-	22	25.8
SAB 100 NBR-60 M10-AG	77	110	4.0	100.8	M10-M	56.6	12	-	22	25.8
SAB 100 NBR-60 M14x1.5-AG	77	110	6.0	100.8	M14x1.5-M	56.6	12	-	22	25.8
SAB 100 NBR-60 RA	77	110	6.0	100.8	-	56.3	-	32	-	25.8
SAB 125 NBR-60 G1/4-AG	94	135	6.0	126.0	G1/4"-M	67.8	10	-	22	32.0
SAB 125 NBR-60 G1/4-IG	94	135	6.0	126.0	G1/4"-F	72.8	20	-	22	32.0
SAB 125 NBR-60 G3/8-IG	94	135	9.0	126.0	G3/8"-F	67.8	15	-	22	32.0
SAB 125 NBR-60 M10-AG	94	135	4.0	126.0	M10-M	67.8	12	-	22	32.0
SAB 125 NBR-60 M14x1.5-AG	94	135	6.0	126.0	M14x1.5-M	67.8	12	-	22	32.0
SAB 125 NBR-60 RA	94	135	6.0	126.0	-	67.5	-	32	-	32.0

\*Acceptable dimensional tolerances for rubber parts concerning to DIN ISO 3302-1 M3

\*\*External dimension of the suction cup when it is pressed against the workpiece by the vacuum

# Flat Suction Cups SAOF (Oval)

Suction area (LxW) from 50 x 16 mm to 140 x 70 mm

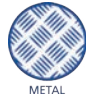

## Suitability for Industry Specific Applications

### Applications

- Oval, flat suction cup for dynamic handling of metal sheets with short cycle times
- Handling of thin steel sheets and aluminum sheets without deformation or deep-drawing
- For use e.g. in feeder systems for press lines in the automotive industry
- Handling of long, narrow metal sheet parts, e.g. reinforcing ribs and plates
- Groove on the bottom prevents oily sheets from slipping and permits precise positioning in stamping presses etc.



Flat Suction Cups SAOF (Oval)

### Design

- Robust, wear-resistant oval suction cup SAOF made of NBR with single sealing lip, special groove and inner support
- Connection nipple glued to the suction cup with a reinforcing element (very high strength)
- Suction cup available with various connection types
- Available in two material hardness values (45 Shore, 60 Shore)

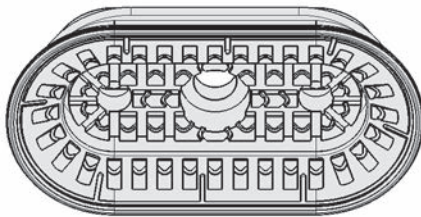

System Design Flat Suction Cups SAOF (Oval)

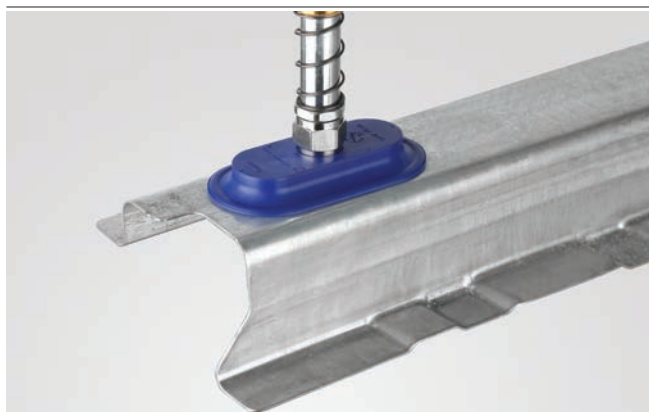

Flat suction cups SAOF being used for handling pressed sheet-metal parts

### Our Highlights...

- Wide range of sizes
- Large, structured inner support
- Flat, oval suction cup
- Soft and flexible sealing lip

### Your Benefits...

- For a wide range of workpiece sizes and shapes
- No deep-drawing of the workpiece; capable of handling high lateral forces, even on oily metal sheets
- Handling of long, narrow workpieces (sections, tubes) or flat workpieces with bars
- Good sealing

# Suction Cups for Handling Sheet Metal

## Flat Suction Cups SAOF (Oval)



Suction area (LxW) from 50 x 16 mm to 140 x 70 mm



### Designation Code Flat Suction Cups SAOF (Oval)

<b>SAOF</b>	-	<b>80x40</b>	-	<b>NBR-60</b>	-	<b>G1/4-IG</b>
<b>1</b>		<b>2</b>		<b>3</b>		<b>4</b>

#### 1 – Abbreviated designation

Code	Version
SAOF	Flat, oval

#### 2 – Suction area

Code	LxW in mm
50x16...140x70	50x16 to 140x70

#### 3 – Material

Code	Material
NBR-45	Nitrile caoutchuc
NBR-60	Nitrile caoutchuc

#### 4 – Connection

Code	Connection
G1/4-AG	G1/4-AG (AG = male (M))
G1/4-IG	G1/4-IG (IG = female (F))
G3/8-IG	G3/8-IG
M10-AG	M10-AG
M14x1.5-AG	M14x1.5-AG
RA	Rectangular adapter

Suction cup SAOF, available in various diameters, is delivered with connection nipple vulcanized to elastomer part.



### Ordering Data Flat Suction Cups SAOF (Oval)

Type	Vacuum connection:							
	G1/4-F	G1/4-M	G3/8-F	M10-M	M14x1.5-M	Rectangular adapter		
SAOF 50x16 NBR 45	10.01.05.00551	10.01.05.00550	10.01.05.00553	10.01.05.00555	10.01.05.00556	10.01.05.00554		
SAOF 50x16 NBR 60	10.01.05.00511	10.01.05.00521	10.01.05.00518	10.01.05.00527	10.01.05.00530	10.01.05.00515		
SAOF 60x23 NBR 45	10.01.05.00560	10.01.05.00559	10.01.05.00562	10.01.05.00564	10.01.05.00565	10.01.05.00563		
SAOF 60x23 NBR 60	10.01.05.00367	10.01.05.00376	10.01.05.00370	10.01.05.00382	10.01.05.00385	10.01.05.00373		
SAOF 80x40 NBR 45	10.01.05.00578	10.01.05.00577	10.01.05.00579	10.01.05.00581	10.01.05.00582	10.01.05.00580		
SAOF 80x40 NBR 60	10.01.05.00269	10.01.05.00314	10.01.05.00293	10.01.05.00329	10.01.05.00344	10.01.05.00299		
SAOF 90x30 NBR 45	10.01.05.00569	10.01.05.00568	10.01.05.00570	10.01.05.00572	10.01.05.00573	10.01.05.00571		
SAOF 90x30 NBR 60	10.01.05.00266	10.01.05.00311	10.01.05.00290	10.01.05.00326	10.01.05.00341	10.01.05.00296		
SAOF 100x50 NBR 45	10.01.05.00587	10.01.05.00586	10.01.05.00588	10.01.05.00590	10.01.05.00591	10.01.05.00589		
SAOF 100x50 NBR 60	10.01.05.00281	10.01.05.00317	10.01.05.00272	10.01.05.00332	10.01.05.00347	10.01.05.00302		
SAOF 120x60 NBR 45	10.01.05.00595	10.01.05.00594	10.01.05.00596	10.01.05.00598	10.01.05.00599	10.01.05.00597		
SAOF 120x60 NBR 60	10.01.05.00284	10.01.05.00320	10.01.05.00275	10.01.05.00335	10.01.05.00350	10.01.05.00305		
SAOF 140x70 NBR 45	10.01.05.00604	10.01.05.00603	10.01.05.00605	10.01.05.00607	10.01.05.00608	10.01.05.00606		
SAOF 140x70 NBR 60	10.01.05.00287	10.01.05.00323	10.01.05.00278	10.01.05.00338	10.01.05.00353	10.01.05.00308		



Schmalz – The Company  
Vacuum Suction Cups  
Special Grippers  
Gripping Systems  
Clamping Systems  
Mounting Elements  
Vacuum Generators  
Valve Technology  
Switches and Monitoring  
Filters and Connections  
Services  
Contact  
Glossary  
Index of Products

# Flat Suction Cups SAOF (Oval)

Suction area (LxW) from 50 x 16 mm to 140 x 70 mm

Schmalz - The Company  
 Vacuum Suction Cups  
 Special Grippers  
 Gripping Systems  
 Clamping Systems  
 Mounting Elements  
 Vacuum Generators  
 Valve Technology  
 Switches and Monitoring  
 Filters and Connections  
 Services  
 Contact  
 Glossary  
 Index of Products



## Technical Data Flat Suction Cups SAOF (Oval)

Type	Suction force [N]*	Lateral force [N]**	Lateral force oily surface [N]	Volume [cm³]	Workpiece radius min. (convex) [mm]	Hose diameter (recom.) d [mm]***
SAOF 50x16	31	24	12	2.3	8	4
SAOF 60x23	57	37	33	3.9	20	4
SAOF 80x40	140	110	100	11.7	50	4
SAOF 100x50	217	181	121	21.8	75	6
SAOF 120x60	312	254	170	39.9	75	6
SAOF 140x70	425	344	230	57.3	90	6

\*The specified suction forces are theoretical values at a vacuum of -0.6 bar and with a smooth, dry workpiece surface - they do not include a safety factor

\*\*The specified lateral forces are values measured at a vacuum of -0.6 bar with a dry or oily, smooth, flat workpiece surface. Depending on the workpiece surface and its quality, the actual values may deviate from these values.

\*\*\*The recommended hose diameter refers to a hose length of approx. 2 m



## Design Data Flat Suction Cups SAOF (Oval)

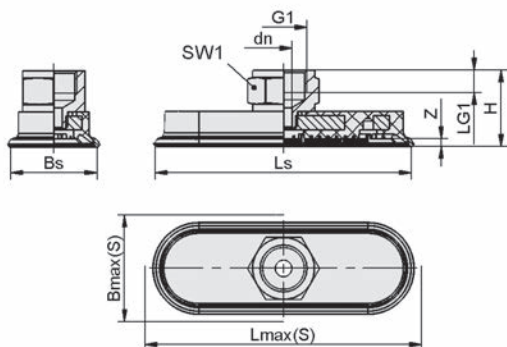

SAOF IG

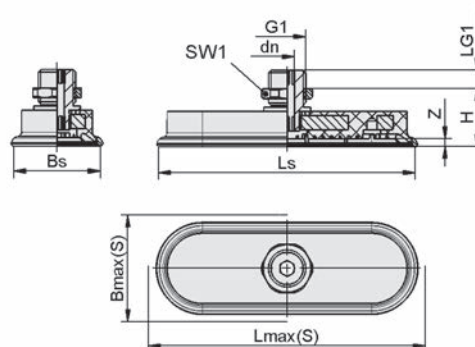

SAOF AG

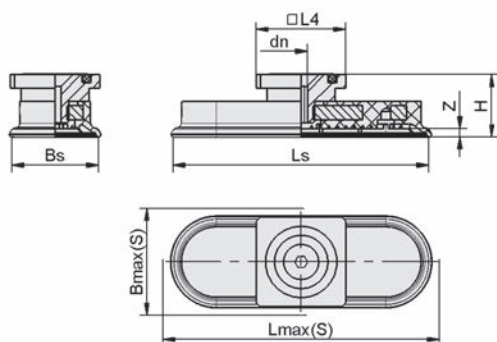

SAOF RA



# Suction Cups for Handling Sheet Metal

## Flat Suction Cups SAOF (Oval)



Suction area (LxW) from 50 x 16 mm to 140 x 70 mm



### Design Data Flat Suction Cups SAOF (Oval)

Type*	Bmax(S) [mm]**	Bs [mm]	dn [mm]	G1	H [mm]	L4 [mm]	LG1 [mm]	Lmax(S) [mm]***	Ls [mm]	SW1 [mm]	Z (Stroke) [mm]	
SAOF 50x16	G1/4-AG	18	15	5	G1/4"-M	26	-	8	52	48.6	17	3.0
SAOF 50x16	G1/4-IG	18	15	6	G1/4"-F	33	-	8	52	48.6	17	3.0
SAOF 50x16	G3/8-IG	18	15	6	G3/8"-F	34	-	9	52	48.6	22	3.0
SAOF 50x16	M10-AG	18	15	4	M10-M	26	-	10	52	48.6	16	3.0
SAOF 50x16	M14x1.5-AG	18	15	5	M14x1.5-M	28	-	10	52	48.6	22	3.0
SAOF 50x16	RA	18	15	4	-	29	32	-	52	48.6	-	3.0
SAOF 60x23	G1/4-AG	25	22	5	G1/4"-M	18	-	8	64	60.6	17	3.0
SAOF 60x23	G1/4-IG	25	22	6	G1/4"-F	26	-	8	64	60.6	17	3.0
SAOF 60x23	G3/8-IG	25	22	6	G3/8"-F	26	-	9	64	60.6	22	3.0
SAOF 60x23	M10-AG	25	22	4	M10-M	18	-	10	64	60.6	16	3.0
SAOF 60x23	M14x1.5-AG	25	22	5	M14x1.5-M	20	-	10	64	60.6	22	3.0
SAOF 60x23	RA	25	22	4	-	21	32	-	64	60.6	-	3.0
SAOF 80x40	G1/4-AG	43	39	5	G1/4"-M	20	-	8	85	80.6	17	4.0
SAOF 80x40	G1/4-IG	43	39	6	G1/4"-F	28	-	8	85	80.6	17	4.0
SAOF 80x40	G3/8-IG	43	39	6	G3/8"-F	28	-	9	85	80.6	22	4.0
SAOF 80x40	M10-AG	43	39	4	M10-M	20	-	10	85	80.6	17	4.0
SAOF 80x40	M14x1.5-AG	43	39	5	M14x1.5-M	22	-	10	85	80.6	22	4.0
SAOF 80x40	RA	43	39	4	-	23	32	-	85	80.6	-	4.0
SAOF 90x30	G1/4-AG	34	31	5	G1/4"-M	19	-	8	94	90.6	17	3.0
SAOF 90x30	G1/4-IG	34	31	6	G1/4"-F	26	-	8	94	90.6	17	3.0
SAOF 90x30	G3/8-IG	34	31	6	G3/8"-F	27	-	9	94	90.6	22	3.0
SAOF 90x30	M10-AG	34	31	4	M10-M	19	-	10	94	90.6	17	3.0
SAOF 90x30	M14x1.5-AG	34	31	5	M14x1.5-M	21	-	10	94	90.6	22	3.0
SAOF 90x30	RA	34	31	4	-	22	32	-	94	90.6	-	3.0
SAOF 100x50	G1/4-AG	54	49	6	G1/4"-M	22	-	8	106	101.1	17	5.0
SAOF 100x50	G1/4-IG	54	49	8	G1/4"-F	30	-	8	106	101.1	17	5.0
SAOF 100x50	G3/8-IG	54	49	8	G3/8"-F	31	-	9	106	101.1	22	5.0
SAOF 100x50	M10-AG	54	49	4	M10-M	22	-	10	106	101.1	17	5.0
SAOF 100x50	M14x1.5-AG	54	49	6	M14x1.5-M	24	-	10	106	101.1	22	5.0
SAOF 100x50	RA	54	49	6	-	25	32	-	106	101.1	-	5.0
SAOF 120x60	G1/4-AG	65	58	6	G1/4"-M	24	-	8	128	126.6	17	6.0
SAOF 120x60	G1/4-IG	65	58	8	G1/4"-F	32	-	8	128	126.6	17	6.0
SAOF 120x60	G3/8-IG	65	58	8	G3/8"-F	33	-	9	128	126.6	22	6.0
SAOF 120x60	M10-AG	65	58	4	M10-M	24	-	10	128	126.6	17	6.0
SAOF 120x60	M14x1.5-AG	65	58	6	M14x1.5-M	26	-	10	128	126.6	22	6.0
SAOF 120x60	RA	65	58	6	-	27	32	-	128	126.6	-	6.0
SAOF 140x70	G1/4-AG	76	68	6	G1/4"-M	25	-	8	149	140.6	17	7.0
SAOF 140x70	G1/4-IG	76	68	8	G1/4"-F	33	-	8	149	140.6	17	7.0
SAOF 140x70	G3/8-IG	76	68	8	G3/8"-F	34	-	9	149	140.6	22	7.0
SAOF 140x70	M10-AG	76	68	4	M10-M	25	-	10	149	140.6	17	7.0
SAOF 140x70	M14x1.5-AG	76	68	6	M14x1.5-M	27	-	10	149	140.6	22	7.0
SAOF 140x70	RA	76	68	6	-	28	32	-	149	140.6	-	7.0

\*Acceptable dimensional tolerances for rubber parts concerning to DIN ISO 3302-1 M3

\*\*External dimension of the suction cup when it is pressed against the workpiece by the vacuum

\*\*\*External dimension of the suction cup when it is pressed against the workpiece by the vacuum

# Bellows Suction Cups SAOB (Oval, 1.5 Folds)

Suction area (LxW) from 60 x 30 mm to 140 x 70 mm



## Suitability for Industry Specific Applications

### Applications

- Oval bellows suction cup with 1.5 folds for dynamic handling of long, narrow workpieces e.g. reinforcing ribs and plates
- Handling of thin steel sheets and aluminum sheets without deformation or deep-drawing
- For use e.g. in feeder systems for press lines in the automotive industry
- Groove on the bottom prevents the oily sheets from slipping and permits precise positioning in stamping presses etc.



Bellows Suction Cups SAOB (Oval, 1.5 Folds)

### Design

- Robust, wear-resistant oval suction cup SAOB with 1.5 folds made of NBR, single sealing lip, special groove and inner support
- Connection nipple glued to the suction cup with a reinforcing element (very high strength)
- Suction cups available with various connection types

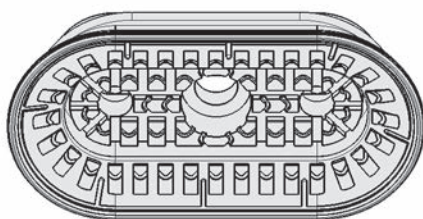

System Design Bellows Suction Cups SAOB (Oval, 1.5 Folds)



Bellows suction cups SAOB being used for handling car bodywork components

### Our Highlights...

- Oval shape with 1.5 folds
- Large, structured inner support
- Wide range of sizes
- Stiff top fold

### Your Benefits...

- For long, narrow workpieces and for stamped bodywork components
- No deep-drawing of the workpiece and handling of very high lateral forces, even with oily metal sheets
- For a wide range of workpiece sizes and shapes
- Resistance to lateral forces and high horizontal accel.

Schmalz – The Company

Vacuum Suction Cups

Special Grippers

Gripping Systems

Clamping Systems

Mounting Elements

Vacuum Generators

Valve Technology

Switches and Monitoring

Filters and Connections

Services

Contact

Glossary

Index of Products



# Bellows Suction Cups SAOB (Oval, 1.5 Folds)

Suction area (LxW) from 60 x 30 mm to 140 x 70 mm



## Designation Code Bellows Suction Cups SAOB (Oval, 1.5 Folds)

<b>SAOB</b>	-	<b>60x30</b>	-	<b>NBR-60</b>	-	<b>RA</b>
<b>1</b>		<b>2</b>		<b>3</b>		<b>4</b>

### 1 – Abbreviated designation

Code	Version
SAOB	1.5 folds, oval

### 2 – Suction area

Code	LxW in mm
60x30...140x70	60x30 to 140x70

### 3 – Material

Code	Material
NBR-60	Nitrile caoutchuc

### 4 – Connection

Code	Connection
G1/4-AG	G1/4-AG (AG = male (M))
G1/4-IG	G1/4-IG (IG = female (F))
G3/8-IG	G3/8-IG
M10-AG	M10-AG
M14x1.5-AG	M14x1.5-AG
RA	Rectangular adapter

Suction cup SAOB, available in various diameters, is delivered with connection nipple vulcanized to elastomer part.



## Ordering Data Bellows Suction Cups SAOB (Oval, 1.5 Folds)

Type*	Vacuum connection:	Vacuum connection:					
		G1/4-F	G1/4-M	G3/8-F	M10-M	M14x1.5-M	Rectangular adapter
SAOB 60x30		10.01.06.00891	10.01.06.00916	10.01.06.00904	10.01.06.01024	10.01.06.01032	10.01.06.00908
SAOB 80x40		10.01.06.00893	10.01.06.00918	10.01.06.00906	10.01.06.01026	10.01.06.01034	10.01.06.00910
SAOB 110x55		10.01.06.00900	10.01.06.00920	10.01.06.00895	10.01.06.01028	10.01.06.01036	10.01.06.00912
SAOB 140x70		10.01.06.00902	10.01.06.00922	10.01.06.00897	10.01.06.01030	10.01.06.01038	10.01.06.00914

\*Additional material specifications at beginning of the section "Vacuum Suction Cups"



## Technical Data Bellows Suction Cups SAOB (Oval, 1.5 Folds)

Type	Suction force [N]*	Pull-off force [N]	Lateral force [N]**	Lateral force oily surface [N]	Volume [cm³]	Workpiece radius min. (convex) [mm]	Hose diameter (recom.) d [mm]***
SAOB 60x30	38	70	73	42	10.5	18	4
SAOB 80x40	65	132	153	74	21.8	25	6
SAOB 110x55	110	234	300	124	53.1	50	6
SAOB 140x70	165	356	473	246	106.0	70	6

\*The specified suction forces are theoretical values at a vacuum of -0.6 bar and with a smooth, dry workpiece surface - they do not include a safety factor

\*\*The specified lateral forces are values measured at a vacuum of -0.6 bar with a dry or oily, smooth, flat workpiece surface. Depending on the workpiece surface and its quality, the actual values may deviate from these values.

\*\*\*The recommended hose diameter refers to a hose length of approx. 2 m

# Bellows Suction Cups SAOB (Oval, 1.5 Folds)

Suction area (LxW) from 60 x 30 mm to 140 x 70 mm

## Design Data Bellows Suction Cups SAOB (Oval, 1.5 Folds)

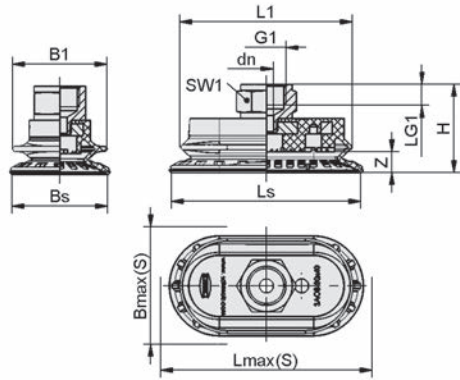

SAOB IG

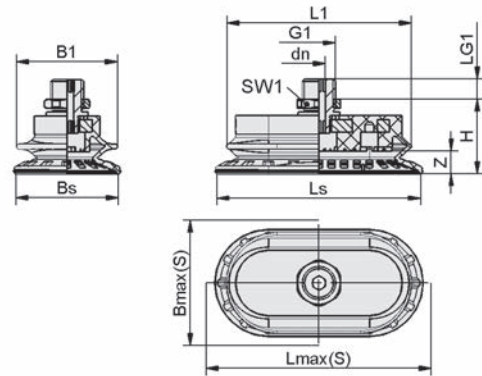

SAOB AG

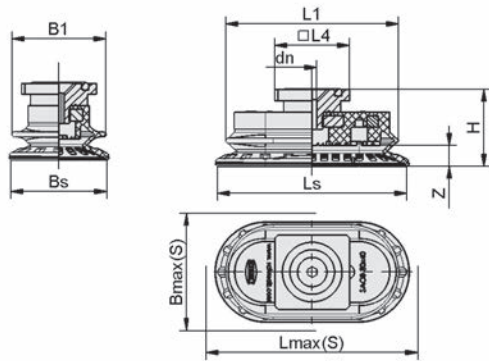

SAOB RA

Type*	B1 [mm]	Bmax(S) [mm]**	Bs [mm]	dn [mm]	G1	H [mm]	LG1 [mm]	L1 [mm]	L4 [mm]	Lmax(S) [mm]***	Ls [mm]	SW1 [mm]	Z (Stroke) [mm]
SAOB 60x30 NBR-60 G1/4-AG	31	33	31	5.0	G1/4"-M	27.0	8	56	-	63	61	17	7
SAOB 60x30 NBR-60 G1/4-IG	31	33	31	5.5	G1/4"-F	34.5	8	56	-	63	61	17	7
SAOB 60x30 NBR-60 G3/8-IG	31	33	31	6.0	G3/8"-F	35.0	9	56	-	63	61	22	7
SAOB 60x30 NBR-60 M10-AG	31	33	31	4.0	M10-M	27.0	10	56	-	63	61	17	7
SAOB 60x30 NBR-60 M14x1.5-AG	31	33	31	5.0	M14x1.5-M	29.0	10	56	-	63	61	22	7
SAOB 60x30 NBR-60 RA	31	33	31	4.0	-	30.0	-	56	32	63	61	-	7
SAOB 80x40 NBR-60 G1/4-AG	40	43	41	5.0	G1/4"-M	29.7	8	74	-	83	81	17	9
SAOB 80x40 NBR-60 G1/4-IG	40	43	41	6.0	G1/4"-F	37.2	8	74	-	83	81	17	9
SAOB 80x40 NBR-60 G3/8-IG	40	43	41	6.0	G3/8"-F	37.7	9	74	-	83	81	22	9
SAOB 80x40 NBR-60 M10-AG	40	43	41	4.0	M10-M	29.7	10	74	-	83	81	17	9
SAOB 80x40 NBR-60 M14x1.5-AG	40	43	41	5.0	M14x1.5-M	31.7	10	74	-	83	81	22	9
SAOB 80x40 NBR-60 RA	40	43	41	4.0	-	32.7	-	74	32	83	81	-	9
SAOB 110x55 NBR-60 G1/4-AG	53	59	56	6.0	G1/4"-M	35.5	8	99	-	114	111	17	12
SAOB 110x55 NBR-60 G1/4-IG	53	59	56	8.0	G1/4"-F	43.0	8	99	-	114	111	17	12
SAOB 110x55 NBR-60 G3/8-IG	53	59	56	8.0	G3/8"-F	43.5	9	99	-	114	111	22	12
SAOB 110x55 NBR-60 M10-AG	53	59	56	4.0	M10-M	35.5	10	99	-	114	111	17	12



## Bellows Suction Cups SAOB (Oval, 1.5 Folds)

Suction area (LxW) from 60 x 30 mm to 140 x 70 mm



### Design Data Bellows Suction Cups SAOB (Oval, 1.5 Folds)

Type*	B1 [mm]	Bmax(S) [mm]**	Bs [mm]	dn [mm]	G1	H [mm]	LG1 [mm]	L1 [mm]	L4 [mm]	Lmax(S) [mm]***	Ls [mm]	SW1 [mm]	Z (Stroke) [mm]
SAOB 110x55 NBR-60 M14x1.5-AG	53	59	56	6.0	M14x1.5-M	37.5	10	99	-	114	111	22	12
SAOB 110x55 NBR-60 RA	53	59	56	6.0	-	38.5	-	99	32	114	111	-	12
SAOB 140x70 NBR-60 G1/4-AG	67	75	71	6.0	G1/4"-M	39.5	8	126	-	146	142	17	17
SAOB 140x70 NBR-60 G1/4-IG	67	75	71	8.0	G1/4"-F	47.0	8	126	-	146	142	17	17
SAOB 140x70 NBR-60 G3/8-IG	67	75	71	8.0	G3/8"-F	47.5	9	126	-	146	142	22	17
SAOB 140x70 NBR-60 M10-AG	67	75	71	4.0	M10-M	39.5	10	126	-	146	142	17	17
SAOB 140x70 NBR-60 M14x1.5-AG	67	75	71	6.0	M14x1.5-M	41.5	10	126	-	146	142	22	17
SAOB 140x70 NBR-60 RA	67	75	71	6.0	-	42.5	-	126	32	146	142	-	17

\*Acceptable dimensional tolerances for rubber parts concerning to DIN ISO 3302-1 M3

\*\*External dimension of the suction cup when it is pressed against the workpiece by the vacuum

\*\*\*External dimension of the suction cup when it is pressed against the workpiece by the vacuum

# Bellows Suction Cups SAB2 P (2.5 Folds)

Suction area (Ø) 20 mm



## Suitability for Industry Specific Applications

### Applications

- Round bellows suction cups with 2.5 folds for handling sheet metal parts such as in CNC metal and laser cutting machines
- Applications with requirements for high holding forces and restrictor to lateral forces even on oily and contaminated workpiece surfaces
- Use in area gripping systems and "suction cup carpets"; optional integration of flow restrictor to reduce leakage occurring at partial occupancy



Bellows Suction Cups SAB2 P (2.5 Folds)

### Design

- Round bellows suction cups SAB2 P (3) with 2.5 folds and radial ribs and sealing lip with sealing edge
- Machine side existing hole for tool-free assembly through push-in function (1)
- Optional integration of flow restrictor (2) to reduce leakage occurring at partial occupancy
- Optional integration of a filter (4) as a prefilter (120 micron filtration rating)

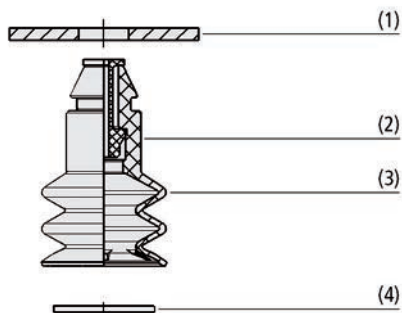

System Design Bellows Suction Cups SAB2 P (2.5 Folds)



Bellows suction cups SAB2 P for handling sheet metal parts

### Our Highlights...

- Tool-free installation by push-in function
- Optimized sealing lip with radial ribs and sealing edge
- Two different materials NBR and HT1

### Your Benefits...

- Quick installation and removal of the suction cups
- High suction power even when used in rough environmental conditions (e.g. oil, chips or dirt)
- High wear and ozone resistance (NBR) and no marks (HT1)

Schmalz – The Company

Vacuum Suction Cups

Special Grippers

Gripping Systems

Clamping Systems

Mounting Elements

Vacuum Generators

Valve Technology

Switches and Monitoring

Filters and Connections

Services

Contact

Glossary

Index of Products



# Bellows Suction Cups SAB2 P (2.5 Folds)

Suction area (Ø) 20 mm



## Designation Code Bellows Suction Cups SAB2 P (2.5 Folds)

<b>SAB2</b>	-	<b>20</b>	-	<b>HT1-60</b>	-	<b>P</b>
<b>1</b>		<b>2</b>		<b>3</b>		<b>4</b>

### 1 – Abbreviated designation

Code	Version
SAB2	2.5 folds

### 2 – Suction area

Code	Diameter in mm
20	ø 20

### 3 – Material

Code	Material
HT1-60	High temperature material
NBR-60	Nitrile caoutchouc

### 4 – Product addition

Code	Type
P	Push-in function

Suction cup SAB2 P is delivered as a ready to connect component.  
Available in materials HT1 and NBR

Available accessories: filter disc (FD), flow restrictor (SW)



## Ordering Data Bellows Suction Cups SAB2 P (2.5 Folds)

Type	Part no.
SAB2 20 HT1-60 P	10.01.06.03235
SAB2 20 NBR-60 P	10.01.06.03263



## Ordering Data Accessories Bellows Suction Cups SAB2 P (2.5 Folds)

Type	Part no.
Flow restrictor SW 80 P 7.3	10.05.04.00090
Flow restrictor SW 100 P 7.3	10.05.04.00091
Flow restrictor SW 130 P 7.3	10.05.04.00092
Flow restrictor SW 150 P 7.3	10.05.04.00093
Filter disc FD 16 120	10.01.06.02565



## Technical Data Bellows Suction Cups SAB2 P (2.5 Folds)

Type	Pull-off force [N]	Suction force [N]*	Volume [cm³]	Workpiece radius min. (convex) [mm]
SAB2 20 HT1-60 P	13	4.7	2.600	20
SAB2 20 NBR-60 P	13	4.7	2.600	20

\*The specified suction forces are theoretical values at a vacuum of -0.6 bar and with a smooth, dry workpiece surface - they do not include a safety factor

# Bellows Suction Cups SAB2 P (2.5 Folds)

Suction area (Ø) 20 mm

**Design Data Bellows Suction Cups SAB2 P (2.5 Folds)**

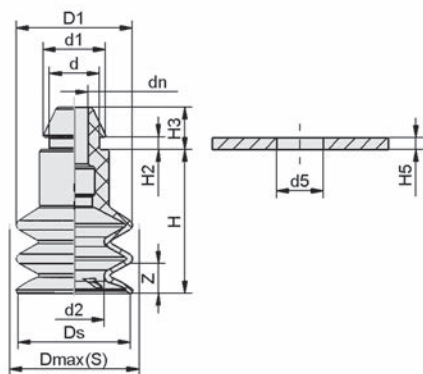

SAB2 P

Type*	d [mm]	d1 [mm]	d2 [mm]	d5 [mm]	D1 [mm]	Dmax(S) [mm]**	dn [mm]	Ds [mm]	H [mm]	H2 [mm]	H3 [mm]	H5 [mm]	Z (Stroke) [mm]
SAB2 20 HT1-60 P	8.5	10.6	10	7.9	19.7	20.5	4.7	19.1	24.5	2.2	7.2	2	9
SAB2 20 NBR-60 P	8.5	10.6	10	7.9	19.7	20.5	4.7	19.1	24.5	2.2	7.2	2	9

\*Acceptable dimensional tolerances for rubber parts concerning to DIN ISO 3302-1 M3

\*\*External dimension of the suction cup when it is pressed against the workpiece by the vacuum

# Flat Suction Cups SHFN

Suction area (Ø) from 50 mm to 85 mm



Flat Suction Cups SHFN

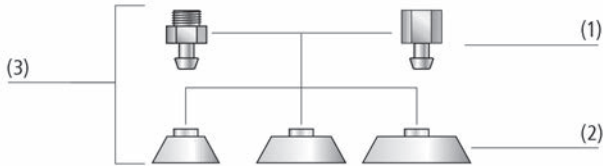

System Design Flat Suction Cups SHFN



Flat suction cups SHFN being used for handling chipboards

## Suitability for Industry Specific Applications

### Applications

- Round, flat suction cup for handling furniture parts, parquet flooring, laminated and unlaminated chipboard, etc.
- Version with vulcanized insert, for vacuum systems in rough operating conditions, where the suction cups are not always fully covered or may be placed directly on the edge of the workpiece
- Handling of objects with very rough surfaces with sealing ring made of special foam

### Design

- Adaptable suction cup SHFN (3), consisting of cup SHF (2) and connection nipple (1)
- Nipple plugged into cup; version SHFN...E with nipple screwed into vulcanized insert
- Ribs on the upper surface of the cup for higher stability on the version without vulcanized insert
- Optionally available with sealing ring made of special foam and/or with touch valve
- Individual deactivation of unused suction cups with optional touch valve to prevent entry of air

### Our Highlights...

- Soft sealing lip
- Sealing lip with inner sealing edge
- Specifically structured lower surface of cup
- Version SHFN...E with integrated insert
- Dirt filter (optional)

### Your Benefits...

- Optimal adaptation to uneven workpiece surfaces
- Very good sealing on rough and smooth surfaces
- Suitable for highly dynamic operations and short cycle times
- Increased stability in rough operating conditions
- Usage in dusty surroundings



# Flat Suction Cups SHFN

Suction area (Ø) from 50 mm to 85 mm



## Designation Code Flat Suction Cups SHFN

<b>SHFN</b>	-	<b>70</b>	-	<b>NK-45</b>	-	<b>G1/4-AG</b>	-	<b>E</b>	-	<b>MOS</b>
<b>1</b>		<b>2</b>		<b>3</b>		<b>4</b>		<b>5</b>		<b>6</b>

### 1 – Abbreviated designation

Code	Version
SHFN	Flat

### 2 – Suction area

Code	Diameter in mm
50...85	ø 50 to 85

### 3 – Material

Code	Material
NK-45	Natural rubber

### 4 – Connection

Code	Connection
G1/4-AG	G1/4-AG (AG = male (M))
G1/4-IG	G1/4-IG (IG = female (F))

### 5 – Type of construction

Code	Type
-	Pluggable metal inlay
E	Vulcanized metal inlay

### 6 – Product addition

Code	Type
MOS	Sealing ring made of special foam
TV	Touch valve

Suction cup SHFN (elastomer part + connection nipple) is delivered assembled.

The assembly consists of:

- Suction cup of type SHF – elastomer part, available in various diameters
- Connection nipple of type SA-NIP – available with various threads
- Optional product addition: sealing ring and touch valve

Available spare parts: suction cup SHF, connection nipple SA-NIP and RED-NIP, sealing ring, touch valve

Available accessories: filter screen (sieve, round)



## Ordering Data Flat Suction Cups SHFN

Type	Vacuum connection:				
	G1/4-AG				
				G1/4-IG	
SHFN 50 - -				10.01.01.11693	10.01.01.11694
SHFN 50 - MOS				10.01.01.11695	10.01.01.11696
SHFN 50 - TV				10.01.01.11699	-
SHFN 50 - MOS-TV				10.01.01.11700	-
SHFN 70 - -				10.01.01.11689	10.01.01.11690
SHFN 70 E -				10.01.01.12197	10.01.01.12216
SHFN 70 - MOS				10.01.01.11691	10.01.01.11692
SHFN 70 E MOS				10.01.01.12217	10.01.01.12218
SHFN 70 - TV				10.01.01.11697	-
SHFN 70 E TV				10.01.01.12221	-
SHFN 70 - MOS-TV				10.01.01.11698	-
SHFN 70 E MOS-TV				10.01.01.12222	-
SHFN 85 - -				10.01.01.11775	10.01.01.11776
SHFN 85 E -				10.01.01.12210	10.01.01.12211
SHFN 85 - MOS				10.01.01.11777	10.01.01.11778
SHFN 85 E MOS				10.01.01.12212	10.01.01.12213
SHFN 85 - TV				10.01.01.11779	-
SHFN 85 E TV				10.01.01.12224	-
SHFN 85 - MOS-TV				10.01.01.11780	-
SHFN 85 E MOS-TV				10.01.01.12225	-



# Flat Suction Cups SHFN

Suction area (Ø) from 50 mm to 85 mm



## Ordering Data Spare Parts Flat Suction Cups SHFN

Type				Spare Parts		Part no.
SHFN	50	-	-	Flat suction cup (round)	SHF 50 NK-45 N041	10.01.01.11687
SHFN	50	-	MOS	Flat suction cup (round)	SHF 50 NK-45 N041 MOS	10.01.01.11688
SHFN	70	-	-	Flat suction cup (round)	SHF 70 NK-45 N041	10.01.01.11682
SHFN	70	-	MOS	Flat suction cup (round)	SHF 70 NK-45 N041 MOS	10.01.01.11686
SHFN	70	E	-	Flat suction cup (round)	SHF 70 NK-45 M10x1.25-IG E	10.01.01.12165
SHFN	70	E	MOS	Flat suction cup (round)	SHF 70 NK-45 M10x1.25-IG E MOS	10.01.01.12215
SHFN	85	-	-	Flat suction cup (round)	SHF 85 NK-45 N041	10.01.01.11773
SHFN	85	-	MOS	Flat suction cup (round)	SHF 85 NK-45 N041 MOS	10.01.01.11774
SHFN	85	E	-	Flat suction cup (round)	SHF 85 NK-45 M10x1.25-IG E	10.01.01.12209
SHFN	85	E	MOS	Flat suction cup (round)	SHF 85 NK-45 M10x1.25-IG E MOS	10.01.01.12223

Type				Spare Parts		Part no.
SHFN	50		MOS	Sealing ring	DR 28/21x3 C03 EPDM-15 KE	10.01.06.01679
SHFN	70		MOS	Sealing ring	DR 46/36x5 S05 EPDM-15 KE	10.01.06.01678
SHFN	85		MOS	Sealing ring	DR 60/50x5 S05 EPDM-15 KE	10.01.06.01720

Type				Spare Parts		Part no.
SHFN	50	NK-45	G1/4-AG	Suction cup connection nipple	SA-NIP N041 G1/4-AG DN440	10.01.01.11772
SHFN	50	NK-45	G1/4-AG MOS	Suction cup connection nipple	SA-NIP N041 G1/4-AG DN440	10.01.01.11772
SHFN	50	NK-45	G1/4-IG	Suction cup connection nipple	SA-NIP N041 G1/4-IG DN440	10.01.01.11822
SHFN	50	NK-45	G1/4-IG MOS	Suction cup connection nipple	SA-NIP N041 G1/4-IG DN440	10.01.01.11822
SHFN	70	NK-45	G1/4-AG	Suction cup connection nipple	SA-NIP N041 G1/4-AG DN440	10.01.01.11772
SHFN	70	NK-45	G1/4-AG MOS	Suction cup connection nipple	SA-NIP N041 G1/4-AG DN440	10.01.01.11772
SHFN	70	NK-45	G1/4-AG E	Reduction nipple with hexagon	RED-NIP-S G1/4-AG M10x1.25-AG AL	10.01.01.12194
SHFN	70	NK-45	G1/4-AG E MOS	Reduction nipple with hexagon	RED-NIP-S G1/4-AG M10x1.25-AG AL	10.01.01.12194
SHFN	70	NK-45	G1/4-IG	Suction cup connection nipple	SA-NIP N041 G1/4-IG DN440	10.01.01.11822
SHFN	70	NK-45	G1/4-IG MOS	Suction cup connection nipple	SA-NIP N041 G1/4-IG DN440	10.01.01.11822
SHFN	70	NK-45	G1/4-IG E	Suction cup connection nipple	SA-NIP N009 G1/4-IG DN440	10.01.01.12192
SHFN	70	NK-45	G1/4-IG E MOS	Suction cup connection nipple	SA-NIP N009 G1/4-IG DN440	10.01.01.12192
SHFN	85	NK-45	G1/4-AG	Suction cup connection nipple	SA-NIP N041 G1/4-AG DN440	10.01.01.11772
SHFN	85	NK-45	G1/4-AG MOS	Suction cup connection nipple	SA-NIP N041 G1/4-AG DN440	10.01.01.11772
SHFN	85	NK-45	G1/4-AG E	Reduction nipple with hexagon	RED-NIP-S G1/4-AG M10x1.25-AG AL	10.01.01.12194
SHFN	85	NK-45	G1/4-AG E MOS	Reduction nipple with hexagon	RED-NIP-S G1/4-AG M10x1.25-AG AL	10.01.01.12194
SHFN	85	NK-45	G1/4-IG	Suction cup connection nipple	SA-NIP N041 G1/4-IG DN440	10.01.01.11822
SHFN	85	NK-45	G1/4-IG MOS	Suction cup connection nipple	SA-NIP N041 G1/4-IG DN440	10.01.01.11822
SHFN	85	NK-45	G1/4-IG E	Suction cup connection nipple	SA-NIP N009 G1/4-IG DN440	10.01.01.12192
SHFN	85	NK-45	G1/4-IG E MOS	Suction cup connection nipple	SA-NIP N009 G1/4-IG DN440	10.01.01.12192

Type				Spare Parts		Part no.
SHFN	50	NK-45	G1/4-AG TV	Touch valve	TVN G1/4-AG 8.4 N041	10.05.10.00058
SHFN	50	NK-45	G1/4-AG MOS-TV	Touch valve	TVN G1/4-AG 8.4 N041	10.05.10.00058
SHFN	70	NK-45	G1/4-AG TV	Touch valve	TVN G1/4-AG 8.4 N041	10.05.10.00058
SHFN	70	NK-45	G1/4-AG MOS-TV	Touch valve	TVN G1/4-AG 8.4 N041	10.05.10.00058
SHFN	70	NK-45	G1/4-AG E TV	Touch valve	TVN G1/4-AG 9 N009	10.05.10.00065
SHFN	70	NK-45	G1/4-AG E MOS-TV	Touch valve	TVN G1/4-AG 9 N009	10.05.10.00065
SHFN	85	NK-45	G1/4-AG TV	Touch valve	TVN G1/4-AG 8.4 N041	10.05.10.00058
SHFN	85	NK-45	G1/4-AG MOS-TV	Touch valve	TVN G1/4-AG 8.4 N041	10.05.10.00058
SHFN	85	NK-45	G1/4-AG E TV	Touch valve	TVN G1/4-AG 9 N009	10.05.10.00065
SHFN	85	NK-45	G1/4-AG E MOS-TV	Touch valve	TVN G1/4-AG 9 N009	10.05.10.00065



# Flat Suction Cups SHFN

Suction area (Ø) from 50 mm to 85 mm



## Ordering Data Accessories Flat Suction Cups SHFN

Type	Accessories	Part no.	
SHFN 50 NK-45 G1/4-AG	Sieve, round	SIEB 15x0.8 MS-A2 0.103/0.07	10.07.01.00211
SHFN 50 NK-45 G1/4-AG MOS	Sieve, round	SIEB 15x0.8 MS-A2 0.103/0.07	10.07.01.00211
SHFN 50 NK-45 G1/4-IG	Sieve, round	SIEB 15x0.8 MS-A2 0.103/0.07	10.07.01.00211
SHFN 50 NK-45 G1/4-IG MOS	Sieve, round	SIEB 15x0.8 MS-A2 0.103/0.07	10.07.01.00211
SHFN 70 NK-45 G1/4-AG	Sieve, round	SIEB 15x0.8 MS-A2 0.103/0.07	10.07.01.00211
SHFN 70 NK-45 G1/4-AG MOS	Sieve, round	SIEB 15x0.8 MS-A2 0.103/0.07	10.07.01.00211
SHFN 70 NK-45 G1/4-AG E	Sieve, round	SIEB 14.5x1 MS-A2 0.103/0.15	10.05.03.00023
SHFN 70 NK-45 G1/4-AG E MOS	Sieve, round	SIEB 14.5x1 MS-A2 0.103/0.15	10.05.03.00023
SHFN 70 NK-45 G1/4-IG	Sieve, round	SIEB 15x0.8 MS-A2 0.103/0.07	10.07.01.00211
SHFN 70 NK-45 G1/4-IG MOS	Sieve, round	SIEB 15x0.8 MS-A2 0.103/0.07	10.07.01.00211
SHFN 70 NK-45 G1/4-IG E	Sieve, round	SIEB 14.5x1 MS-A2 0.103/0.15	10.05.03.00023
SHFN 70 NK-45 G1/4-IG E MOS	Sieve, round	SIEB 14.5x1 MS-A2 0.103/0.15	10.05.03.00023
SHFN 85 NK-45 G1/4-AG	Sieve, round	SIEB 15x0.8 MS-A2 0.103/0.07	10.07.01.00211
SHFN 85 NK-45 G1/4-AG MOS	Sieve, round	SIEB 15x0.8 MS-A2 0.103/0.07	10.07.01.00211
SHFN 85 NK-45 G1/4-AG E	Sieve, round	SIEB 14.5x1 MS-A2 0.103/0.15	10.05.03.00023
SHFN 85 NK-45 G1/4-AG E MOS	Sieve, round	SIEB 14.5x1 MS-A2 0.103/0.15	10.05.03.00023
SHFN 85 NK-45 G1/4-IG	Sieve, round	SIEB 15x0.8 MS-A2 0.103/0.07	10.07.01.00211
SHFN 85 NK-45 G1/4-IG MOS	Sieve, round	SIEB 15x0.8 MS-A2 0.103/0.07	10.07.01.00211
SHFN 85 NK-45 G1/4-IG E	Sieve, round	SIEB 14.5x1 MS-A2 0.103/0.15	10.05.03.00023
SHFN 85 NK-45 G1/4-IG E MOS	Sieve, round	SIEB 14.5x1 MS-A2 0.103/0.15	10.05.03.00023



## Technical Data Flat Suction Cups SHFN

Type*	Suction force d2 [N]**	Suction force [N]**	Lateral force [N]	Volume [cm <sup>3</sup> ]	Workpiece radius min. (convex) [mm]	Hose diameter (recom.) d [mm]****	Nipple family
SHFN 50 - -	40	110	95	7.3	41	4	N 041
SHFN 50 - TV	40	110	95	7.3	41	4	N 041
SHFN 70 E -	100	200	145	16.0	95	6	N 009
SHFN 70 E TV	100	200	145	16.0	95	6	N 009
SHFN 70 - -	100	200	145	16.0	95	6	N 041
SHFN 70 - TV	100	200	145	16.0	95	6	N 041
SHFN 85 E -	175	300	210	25.0	176	6	N 009
SHFN 85 E TV	175	300	210	25.0	176	6	N 009
SHFN 85 - -	175	300	210	25.0	176	6	N 041
SHFN 85 - TV	175	300	210	25.0	176	6	N 041

\*For technical data on the touch valves, see Chapter "Valve Technology"

\*\*Suction force referred to the sealing-edge diameter d2

\*\*\*The specified suction forces are theoretical values at a vacuum of -0.6 bar and with a smooth, dry workpiece surface - they do not include a safety factor

\*\*\*\*The recommended hose diameter refers to a hose length of approx. 2 m



# Flat Suction Cups SHFN

Suction area ( $\varnothing$ ) from 50 mm to 85 mm



## Design Data Flat Suction Cups SHFN

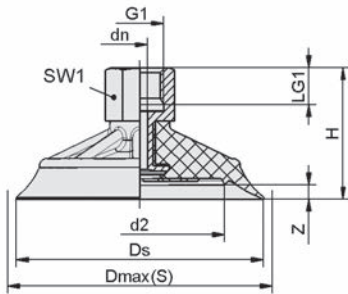

SHFN 50 - 85 G1/4-IG

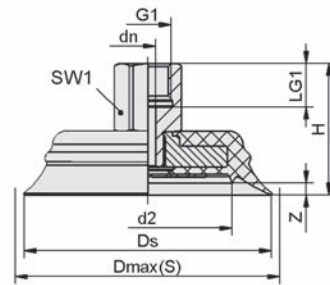

SHFN 70 - 85 G1/4-IG E

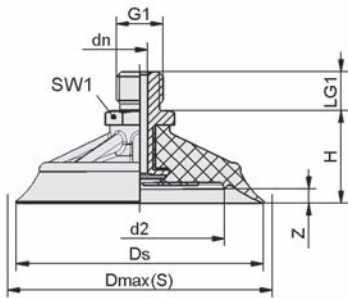

SHFN 50 - 85 G1/4-AG (TV)

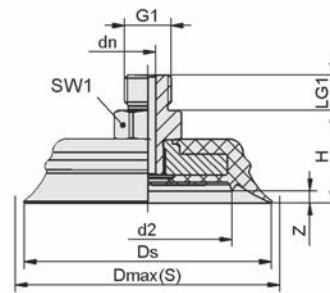

SHFN 70 - 85 G1/4-AG E (TV)

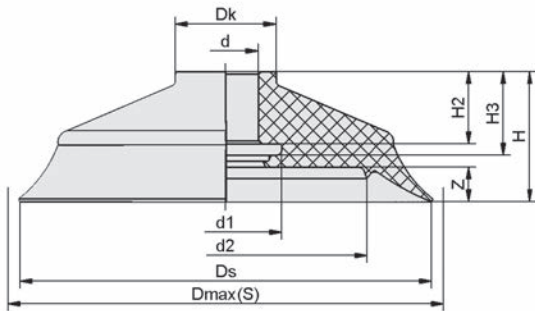

SHF 50 - 85

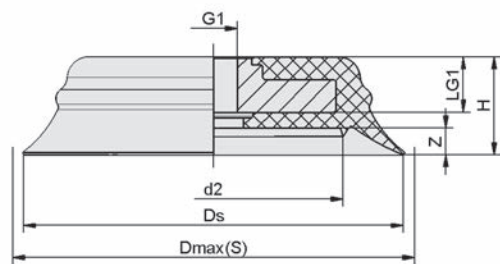

SHF 70 E - 85 E

- Schmalz - The Company
- Vacuum Suction Cups
- Special Grippers
- Gripping Systems
- Clamping Systems
- Mounting Elements
- Vacuum Generators
- Valve Technology
- Switches and Monitoring
- Filters and Connections
- Services
- Contact
- Glossary
- Index of Products

# Flat Suction Cups SHFN

Suction area (Ø) from 50 mm to 85 mm



## Design Data Flat Suction Cups SHFN

Type*	d2 [mm]	Dmax(S) [mm]**	dn [mm]	Ds [mm]	G1	H [mm]	LG1 [mm]	SW1 [mm]	Z (Stroke) [mm]
SHFN 50 - -	30	55	4.4	52.0	G1/4"-M	26.2	11	17	3
SHFN 50 - -	30	55	4.4	52.0	G1/4"-F	37.2	11	17	3
SHFN 50 - TV	30	55	4.4	52.0	G1/4"-M	32.2	11	17	3
SHFN 70 - -	48	74	4.4	70.0	G1/4"-M	26.2	11	17	4
SHFN 70 E -	48	74	4.4	70.0	G1/4"-M	26.2	10	17	4
SHFN 70 - -	48	74	4.4	70.0	G1/4"-F	37.2	11	17	4
SHFN 70 E -	48	74	4.4	70.0	G1/4"-F	37.2	13	17	4
SHFN 70 - TV	48	74	4.4	70.0	G1/4"-M	32.2	11	17	4
SHFN 70 E TV	48	74	4.4	70.0	G1/4"-M	33.4	10	17	4
SHFN 85 - -	62	89	4.4	85.0	G1/4"-M	26.2	11	17	4
SHFN 85 E -	62	89	4.4	85.0	G1/4"-M	26.2	10	17	4
SHFN 85 - -	62	89	4.4	85.0	G1/4"-F	37.2	11	17	4
SHFN 85 E -	62	89	4.4	85.0	G1/4"-F	37.2	13	17	4
SHFN 85 - TV	62	89	4.4	85.0	G1/4"-M	32.2	11	17	4
SHFN 85 E TV	62	89	4.4	85.0	G1/4"-M	33.4	10	17	4

\*Acceptable dimensional tolerances for rubber parts concerning to DIN ISO 3302-1 M3

\*\*External dimension of the suction cup when it is pressed against the workpiece by the vacuum

Type*	d [mm]	d1 [mm]	d2 [mm]	Dk [mm]	Dmax(S) [mm]**	Ds [mm]	G1	H [mm]	H2 [mm]	H3 [mm]	LG1 [mm]	Z (Stroke) [mm]
SHF 50 -	7.5	17.0	30	17.0	55.0	52.0	-	22.2	12.8	14.3	-	3.0
SHF 70 -	7.5	17.0	48	17.0	74.0	70.0	-	22.2	12.8	14.3	-	4.0
SHF 70 E	-	-	48	-	74.0	70.0	M10x1.25-F	18.1	-	-	10	4.0
SHF 85 -	7.5	17.0	62	17.0	89.0	85.0	-	22.2	12.8	14.3	-	4.0
SHF 85 E	-	-	50	-	89.0	85.0	M10x1.25-F	18.1	-	-	10	4.0

\*Acceptable dimensional tolerances for rubber parts concerning to DIN ISO 3302-1 M3

\*\*External dimension of the suction cup when it is pressed against the workpiece by the vacuum

# Suction Plates SHF

Suction area (Ø) from 125 mm to 210 mm



Suction Plates SHF

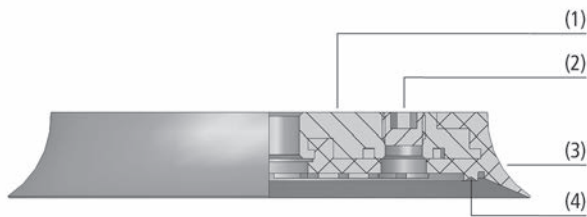

System Design Suction Plates SHF



Suction plates SHF being used for handling pressed wooden boards

## Suitability for Industry Specific Applications

### Applications

- Round suction plate for handling of sheets, furniture elements, parquet and similar large, flat workpieces
- Handling of wooden parts with rough surfaces

### Design

- Suction plate SHF, consisting of sealing ring (3) and aluminum mounting plate (1)
- Connection (2) on the side, normally sealed with a screw plug (glued into position for extra safety)
- Sealing ring clipped securely to mounting plate (can be changed without tools)
- Double internal sealing edge (4) for better sealing to rough surfaces
- Optional touch valve can be ordered separately (use medium-strength locking compound for installation)
- Filter screen available optionally

### Our Highlights...

- Soft sealing lip
- Double internal sealing edge
- Specifically structured lower surface
- Modular design

### Your Benefits...

- Optimal adaptation to uneven workpiece surfaces
- Very good sealing on rough and smooth surfaces
- Highly dynamic movement and short cycle times
- Gasket can be changed quickly without tools

# Suction Plates SHF

Suction area (Ø) from 125 mm to 210 mm



## Designation Code Suction Plates SHF

SHF	-	210	-	NK-45	-	G1/2-IG
1		2		3		4

### 1 – Abbreviated designation

Code	Version
SHF	Flat

### 2 – Suction area

Code	Diameter in mm
125...210	ø 125 to 210

### 3 – Material

Code	Material
NK-45	Natural rubber

### 4 – Connection

Code	Connection
G1/4-IG	G1/4-IG (IG = female (F))
G1/2-IG	G1/2-IG

Suction plate SHF (sealing ring + support plate) is delivered assembled. The assembly consists of:

- Sealing ring of type DR-SHF – elastomer part, available in various diameters
- Aluminum support plate – available with various threads

Available spare parts: sealing ring DR-SHF

Available accessories: touch valve, filter screen



## Ordering Data Suction Plates SHF

Type*	Part no.
SHF 125 NK-45 G1/4-IG	10.01.01.11788
SHF 160 NK-45 G1/2-IG	10.01.01.12025
SHF 210 NK-45 G1/2-IG	10.01.01.11814

\*Additional material specifications at beginning of the section "Vacuum Suction Cups"



## Ordering Data Spare Parts Suction Plates SHF

Type	Spare Parts		Part no.
SHF 125 NK-45 G1/4-IG	Sealing ring for SHF suction plate	DR-SHF 125 NK-45	10.01.01.11783
SHF 160 NK-45 G1/2-IG	Sealing ring for SHF suction plate	DR-SHF 160 NK-45	10.01.01.12023
SHF 210 NK-45 G1/2-IG	Sealing ring for SHF suction plate	DR-SHF 210 NK-45	10.01.01.11809



## Ordering Data Accessories Suction Plates SHF

Type	Accessories		Part no.
SHF 125 NK-45 G1/4-IG	Touch Valve	TV G1/4-AG 13	10.05.10.00061
SHF 160 NK-45 G1/2-IG	Touch Valve	TV G1/4-AG 13	10.05.10.00061
SHF 210 NK-45 G1/2-IG	Touch Valve	TV G1/4-AG 13	10.05.10.00061

Type	Accessories		Part no.
SHF 125 NK-45 G1/4-IG	Filter screen (outside)	SIEB 19.5x1 MS 100	10.07.01.00215
SHF 160 NK-45 G1/2-IG	Filter screen (outside)	SIEB 19.5x1 MS 100	10.07.01.00215
SHF 210 NK-45 G1/2-IG	Filter screen (outside)	SIEB 19.5x1 MS 100	10.07.01.00215



# Suction Plates SHF

Suction area ( $\emptyset$ ) from 125 mm to 210 mm

## Ordering Data Accessories Suction Plates SHF

Type	Accessories	Part no.
SHF 125 NK-45 G1/4-IG	Filter screen (center) SIEB 19.5x1 MS 100	10.07.01.00215
SHF 160 NK-45 G1/2-IG	Filter screen (center) SIEB 27x1 MS-A2 100	10.07.01.00110
SHF 210 NK-45 G1/2-IG	Filter screen (center) SIEB 27x1 MS-A2 100	10.07.01.00110



## Technical Data Suction Plates SHF

Type	Suction force [N]*	Suction force d2 [N]**	Volume [cm <sup>3</sup> ]	Workpiece radius min. (convex) [mm]	Hose diameter (recom.) d [mm]***
SHF 125 NK-45 G1/4-IG	625	290	70	305	9
SHF 160 NK-45 G1/2-IG	1,025	580	117	500	12
SHF 210 NK-45 G1/2-IG	1,770	1,160	224	885	12

\*The specified suction forces are theoretical values at a vacuum of -0.6 bar and with a smooth, dry workpiece surface - they do not include a safety factor

\*\*Suction force referred to the sealing-edge diameter d2

\*\*\*The recommended hose diameter refers to a hose length of approx. 2 m



## Design Data Suction Plates SHF

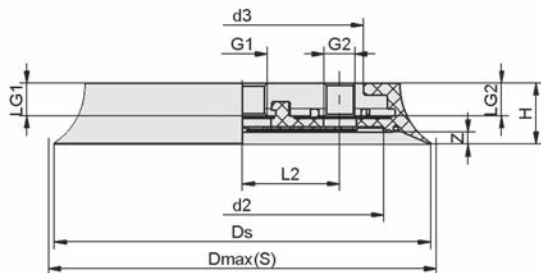

SHF

Type*	d2 [mm]	d3 [mm]	Dmax(S) [mm]**	Ds [mm]	G1	G2***	H [mm]	L2 [mm]	LG1 [mm]	LG2 [mm]	Z (Stroke) [mm]
SHF 125 NK-45 G1/4-IG	85	70	133	125	G1/4"-F	G1/4"-F	26	26.5	14	12.8	6
SHF 160 NK-45 G1/2-IG	120	103	168	160	G1/2"-F	G1/4"-F	26	41.4	14	12.8	6
SHF 210 NK-45 G1/2-IG	170	134	218	210	G1/2"-F	G1/4"-F	26	52.8	14	12.8	6

\*Acceptable dimensional tolerances for rubber parts concerning to DIN ISO 3302-1 M3

\*\*External dimension of the suction cup when it is pressed against the workpiece by the vacuum

\*\*\*A plug is fitted in this connection in the factory



# Flat Suction Cups SPF

Suction area (Ø) from 10 mm to 60 mm



## Suitability for Industry Specific Applications

### Applications

- Round, flat suction cup for usage in cardboard box and tray erectors
- Handling of cardboard and rigid packaging in top-loading and side-loading machines
- Palletizing and depalletizing processes
- Heavy-duty applications that require suction cups with excellent sealing and low wear
- Handling of narrow cardboard boxes with openings, windows or perforation for pharma or cosmetics (especially diameter 10 and 15 mm)



Flat Suction Cups SPF

### Design

- Round flat suction cup SPF (2) with soft, flexible sealing lip and supporting studs on the suction surface
- Made of wear-proof material Elastodur ED-65
- Models with diameter up to 30 mm feature plug-in connection element for quick change of suction cup
- Starting at 40 mm diameter with a 2-piece connection element: consisting of machine-side component (1) and suction-side component (3)
- Clip-in filter screen (4) as pre-filter (filter pore size 250 µm)
- All connection elements with male thread are equipped with integrated sealing

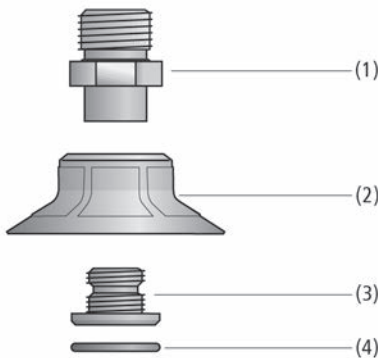

System Design Flat Suction Cups SPF



Flat suction cups SPF for use in carton erectors

### Our Highlights...

- Flexible, adaptable sealing lip
- Robust, reinforced main body
- Supporting studs on the suction surface
- Wear-proof and abrasion-proof material Elastodur ED-65

### Your Benefits...

- Excellent sealing when used on cardboard and rigid packaging
- High intrinsic stability of the suction cup
- Maximum effective diameter for high suction force
- Very low wear, approx. 3 times higher compared to NBR

# Flat Suction Cups SPF

Suction area (Ø) from 10 mm to 60 mm



## Designation Code Flat Suction Cups SPF

<b>SPF</b>	-	<b>20</b>	-	<b>ED-65</b>	-	<b>G1/8-AG</b>
1		2		3		4

### 1 – Abbreviated designation

Code	Version
SPF	Flat

### 2 – Suction area

Code	Diameter in mm
10...60	ø 10 to 60

### 3 – Material

Code	Material
ED-65	Elastodur

### 4 – Connection

Code	Connection
M5-IG	M5-IG (IG = female (F))
G1/8-AG	G1/8-AG (AG = male (M))
G1/8-IG	G1/8-IG
G1/4-AG	G1/4-AG
G1/4-IG	G1/4-IG

Suction cup SPF (elastomer part + connection element) is delivered assembled. The assembly consists of:

- Suction cup of type SPF – elastomer part, available in various diameters
- Connection element of type SC – available with various threads

Available spare parts: suction cup SPF, Schmalz-Connector

Available accessories: filter screen (sieve, round)



## Ordering Data Flat Suction Cups SPF

Type*	Part no.
SPF 10 ED-65 M5-IG	10.01.01.13254
SPF 15 ED-65 G1/8-AG	10.01.01.13238
SPF 15 ED-65 G1/8-IG	10.01.01.13239
SPF 20 ED-65 G1/8-AG	10.01.01.13240
SPF 20 ED-65 G1/8-IG	10.01.01.13241
SPF 25 ED-65 G1/8-AG	10.01.01.13242
SPF 25 ED-65 G1/8-IG	10.01.01.13243
SPF 30 ED-65 G1/8-AG	10.01.01.13244
SPF 30 ED-65 G1/8-IG	10.01.01.13245
SPF 40 ED-65 G1/4-AG	10.01.01.13246
SPF 40 ED-65 G1/4-IG	10.01.01.13247
SPF 50 ED-65 G1/4-AG	10.01.01.13248
SPF 50 ED-65 G1/4-IG	10.01.01.13249
SPF 60 ED-65 G1/4-AG	10.01.01.13250
SPF 60 ED-65 G1/4-IG	10.01.01.13251

\*Additional material specifications at beginning of the section "Vacuum Suction Cups"

# Flat Suction Cups SPF

Suction area (Ø) from 10 mm to 60 mm



## Ordering Data Spare Parts Flat Suction Cups SPF

Type	Spare Parts		Part no.
SPF 10	Flat suction cup (round)	SPF 10 ED-65 SC030	10.01.01.12894
SPF 15	Flat suction cup (round)	SPF 15 ED-65 SC040	10.01.01.12895
SPF 20	Flat suction cup (round)	SPF 20 ED-65 SC040	10.01.01.12370
SPF 25	Flat suction cup (round)	SPF 25 ED-65 SC040	10.01.01.12371
SPF 30	Flat suction cup (round)	SPF 30 ED-65 SC040	10.01.01.12372
SPF 40	Flat suction cup (round)	SPF 40 ED-65 SC050	10.01.01.12373
SPF 50	Flat suction cup (round)	SPF 50 ED-65 SC050	10.01.01.12374
SPF 60	Flat suction cup (round)	SPF 60 ED-65 SC050	10.01.01.12896

Type	Spare Parts		Part no.
SPF 10 ED-65 M5-AG	Schmalz-Connector	SC 030 M5-AG	10.01.06.02802
SPF 10 ED-65 M5-IG	Schmalz-Connector	SC 030 M5-IG	10.01.06.03440
SPF 15 ED-65 G1/8-AG	Schmalz-Connector	SC 040 G1/8-AG	10.01.06.02490
SPF 15 ED-65 G1/8-IG	Schmalz-Connector	SC 040 G1/8-IG	10.01.06.02482
SPF 20 ED-65 G1/8-AG	Schmalz-Connector	SC 040 G1/8-AG	10.01.06.02490
SPF 20 ED-65 G1/8-IG	Schmalz-Connector	SC 040 G1/8-IG	10.01.06.02482
SPF 25 ED-65 G1/8-AG	Schmalz-Connector	SC 040 G1/8-AG	10.01.06.02490
SPF 25 ED-65 G1/8-IG	Schmalz-Connector	SC 040 G1/8-IG	10.01.06.02482
SPF 30 ED-65 G1/8-AG	Schmalz-Connector	SC 040 G1/8-AG	10.01.06.02490
SPF 30 ED-65 G1/8-IG	Schmalz-Connector	SC 040 G1/8-IG	10.01.06.02482
SPF 40 ED-65 G1/4-AG	Schmalz-Connector	SC 050 G1/4-AG	10.01.06.02487
SPF 40 ED-65 G1/4-IG	Schmalz-Connector	SC 050 G1/4-IG	10.01.06.02488
SPF 50 ED-65 G1/4-AG	Schmalz-Connector	SC 050 G1/4-AG	10.01.06.02487
SPF 50 ED-65 G1/4-IG	Schmalz-Connector	SC 050 G1/4-IG	10.01.06.02488
SPF 60 ED-65 G1/4-AG	Schmalz-Connector	SC 050 G1/4-AG	10.01.06.02487
SPF 60 ED-65 G1/4-IG	Schmalz-Connector	SC 050 G1/4-IG	10.01.06.02488



## Ordering Data Accessories Flat Suction Cups SPF

Type	Accessories		Part no.
SPF 10	-	-	-
SPF 15	-	-	-
SPF 20	Sieve, round	SIEB 11x1 MS-A2 280 0.28/0.16	10.07.01.00309
SPF 25	Sieve, round	SIEB 11x1 MS-A2 280 0.28/0.16	10.07.01.00309
SPF 30	Sieve, round	SIEB 11x1 MS-A2 280 0.28/0.16	10.07.01.00309
SPF 40	Sieve, round	SIEB 17.5x0.8 MS-A2 280 0.28/0.16	10.07.01.00308
SPF 50	Sieve, round	SIEB 17.5x0.8 MS-A2 280 0.28/0.16	10.07.01.00308
SPF 60	Sieve, round	SIEB 17.5x0.8 MS-A2 280 0.28/0.16	10.07.01.00308





# Flat Suction Cups SPF

Suction area (Ø) from 10 mm to 60 mm



## Technical Data Flat Suction Cups SPF

Type	Suction force [N]*	Pull-off force [N]	Lateral force [N]	Volume [cm³]	Workpiece radius min. (convex) [mm]	Hose diameter (recom.) d [mm]**
SPF 10	4.41	5.2	3.5	0.3	8	4
SPF 15	9.81	11.0	7.9	0.8	13	4
SPF 20	16.00	19.2	10.5	1.2	20	4
SPF 25	22.70	27.1	17.0	1.7	30	4
SPF 30	29.50	35.3	22.5	2.6	35	6
SPF 40	49.50	62.5	25.0	5.1	70	6
SPF 50	74.20	87.4	44.0	8.0	75	6
SPF 60	107.00	135.0	65.0	12.7	75	6

\*The specified suction forces are theoretical values at a vacuum of -0.6 bar and with a smooth, dry workpiece surface - they do not include a safety factor

\*\*The recommended hose diameter refers to a hose length of approx. 2 m



## Design Data Flat Suction Cups SPF

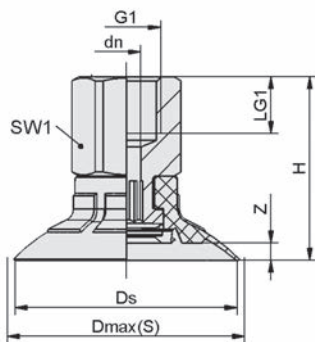

SPF 10 - 30 IG

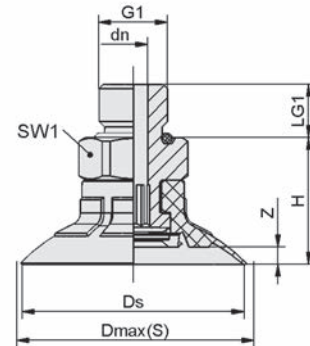

SPF 10 - 30 AG

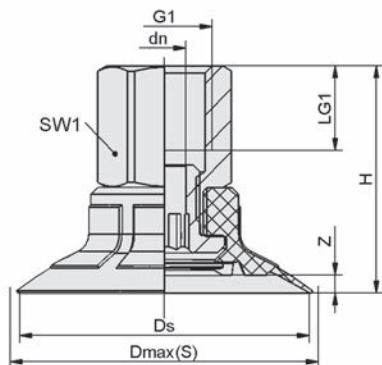

SPF 40 - 60 IG

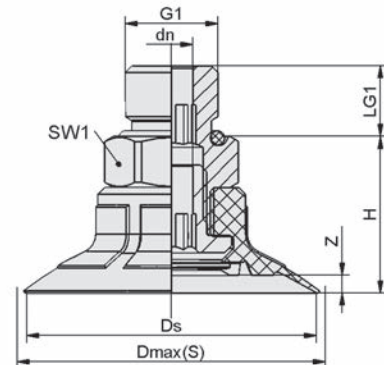

SPF 40 - 60 AG

# Flat Suction Cups SPF

Suction area (Ø) from 10 mm to 60 mm



## Design Data Flat Suction Cups SPF

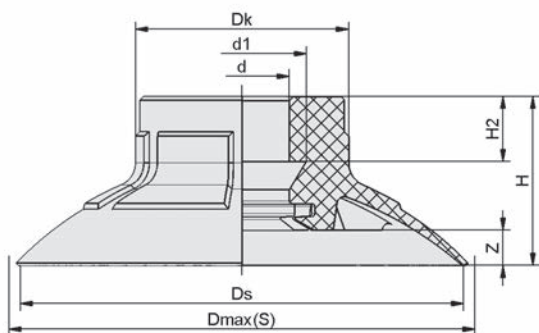

SPF 10 - 30

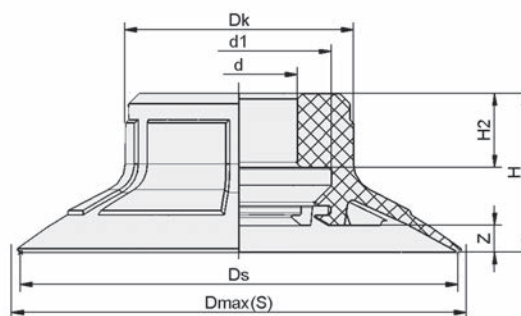

SPF 40 - 60

Type*	dn [mm]	Ds [mm]	Dmax(S) [mm]**	G1	H [mm]	LG1 [mm]	SW1 [mm]	Z (Stroke) [mm]
SPF 10 ED-65 M5-IG	3.1	10.5	12.0	M5-F	19	5.5	8	1.0
SPF 15 ED-65 G1/8-AG	4.1	16.4	18.5	G1/8"-M	16	7.5	14	1.5
SPF 15 ED-65 G1/8-IG	4.1	16.4	18.5	G1/8"-F	24	8.0	14	1.5
SPF 20 ED-65 G1/8-AG	4.1	21.4	23.3	G1/8"-M	17	7.5	14	2.0
SPF 20 ED-65 G1/8-IG	4.1	21.4	23.3	G1/8"-F	25	8.0	14	2.0
SPF 25 ED-65 G1/8-AG	4.1	26.4	28.0	G1/8"-M	17	7.5	14	2.0
SPF 25 ED-65 G1/8-IG	4.1	26.4	28.0	G1/8"-F	25	8.0	14	2.0
SPF 30 ED-65 G1/8-AG	4.1	31.4	33.6	G1/8"-M	18	7.5	14	2.5
SPF 30 ED-65 G1/8-IG	4.1	31.4	33.6	G1/8"-F	26	8.0	14	2.5
SPF 40 ED-65 G1/4-AG	6.1	41.4	43.7	G1/4"-M	23	10.0	17	2.5
SPF 40 ED-65 G1/4-IG	6.1	41.4	43.7	G1/4"-F	33	12.0	17	2.5
SPF 50 ED-65 G1/4-AG	6.1	51.4	53.9	G1/4"-M	24	10.0	17	3.5
SPF 50 ED-65 G1/4-IG	6.1	51.4	53.9	G1/4"-F	34	12.0	17	3.5
SPF 60 ED-65 G1/4-AG	6.1	61.2	65.0	G1/4"-M	26	10.0	17	5.1
SPF 60 ED-65 G1/4-IG	6.1	61.2	65.0	G1/4"-F	36	12.0	17	5.1

\*Acceptable dimensional tolerances for rubber parts concerning to DIN ISO 3302-1 M3

\*\*External dimension of the suction cup when it is pressed against the workpiece by the vacuum

Type*	d [mm]	d1 [mm]	Dk [mm]	Dmax(S) [mm]**	Ds [mm]	H [mm]	H2 [mm]	Z (Stroke) [mm]
SPF 10	5.5	7.2	9.6	12.0	10.5	8.5	4.2	1.0
SPF 15	7.5	10.4	13.0	18.5	16.4	10.0	4.6	1.5
SPF 20	7.5	10.5	15.1	23.3	21.4	11.0	4.6	2.0
SPF 25	7.5	10.5	15.1	28.0	26.4	11.0	4.6	2.0
SPF 30	7.5	10.5	15.1	33.6	31.4	12.0	4.6	2.5
SPF 40	11.0	17.5	21.6	43.7	41.4	15.0	7.0	2.5
SPF 50	11.0	17.5	21.6	53.9	51.4	16.0	7.0	3.5
SPF 60	10.5	17.5	22.1	65.0	61.2	18.1	7.5	5.1

\*Acceptable dimensional tolerances for rubber parts concerning to DIN ISO 3302-1 M3

\*\*External dimension of the suction cup when it is pressed against the workpiece by the vacuum



Schmalz - The Company  
 Vacuum Suction Cups  
 Special Grippers  
 Gripping Systems  
 Clamping Systems  
 Mounting Elements  
 Vacuum Generators  
 Valve Technology  
 Switches and Monitoring  
 Filters and Connections  
 Services  
 Contact  
 Glossary  
 Index of Products

# Bellows Suction Cups SPB1 (1.5 Folds)

Suction area (Ø) from 10 mm to 80 mm



## Suitability for Industry Specific Applications

### Applications

- Round, bellows suction cup with 1.5 folds for the use in cardboard box and tray erectors
- Handling of cardboard and rigid packaging in top-loading and side-loading machines
- Palletizing and depalletizing processes
- Heavy-duty applications that require suction cups with excellent sealing and low wear



Bellows Suction Cups SPB1 (1.5 Folds)

### Design

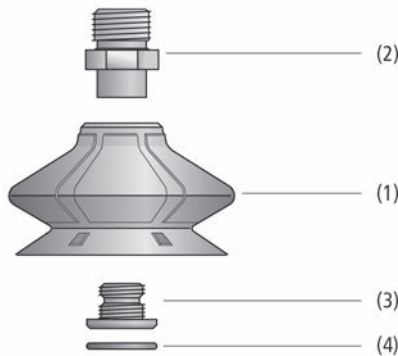

- Round, bellows suction cup SPB1 (1) with 1.5 folds and soft, flexible sealing lip
- Made of wear-proof material Elastodur ED-65
- Models with diameter up to 30 mm feature plug-in connection element
- Starting at 40 mm diameter with a two-piece connection element: consisting of machine-side component (2) and suction-side component (3)
- Clip-in filter screen (4) as pre-filter
- All connection elements with male thread are equipped with integrated sealing

System Design Bellows Suction Cups SPB1 (1.5 Folds)

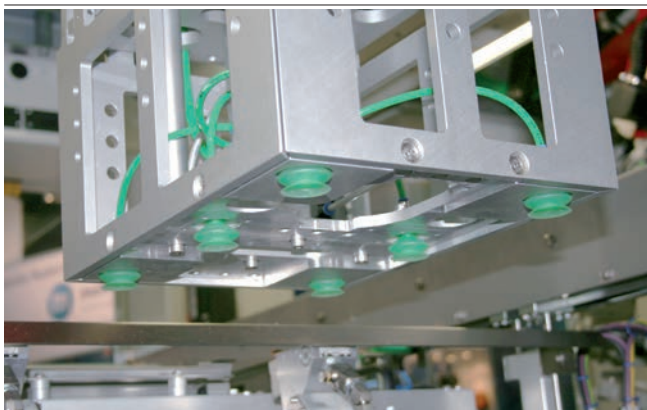

Bellows suction cups SPB1 being used for handling of cardboard

### Our Highlights...

- Flexible, adaptable sealing lip
- Robust, reinforced main body
- Interlocking of sealing-lip and fold due to locking elements
- Large effective suction surface
- Wear-proof and abrasion-proof material Elastodur ED-65

### Your Benefits...

- Excellent sealing performance on cardboard and rigid packaging
- High intrinsic stability in dynamic processes
- Form-locking connection to avoid sliding of the suction cup
- High suction force despite small dimensions
- Very low wear; service life approx. 3 times higher compared to NBR



# Bellows Suction Cups SPB1 (1.5 Folds)

Suction area (Ø) from 10 mm to 80 mm

## Designation Code Bellows Suction Cups SPB1 (1.5 Folds)

<b>SPB1</b>	-	<b>30</b>	-	<b>ED-65</b>	-	<b>G1/8-AG</b>
1		2		3		4

### 1 – Abbreviated designation

Code	Version
SPB1	1.5 folds

### 2 – Suction area

Code	Diameter in mm
10...80	ø 10 to 80

### 3 – Material

Code	Material
ED-65	Elastodur

### 4 – Connection

Code	Connection
M5-AG	M5-AG (AG = male (M))
M5-IG	M5-IG (IG = female (F))
G1/8-AG	G1/8-AG
G1/8-IG	G1/8-IG
G1/4-AG	G1/4-AG
G1/4-IG	G1/4-IG

Suction cup SPB1 (elastomer part + connection element) is delivered assembled. The assembly consists of:

- Suction cup of type SPB1 – elastomer part, available in various diameters
- Connection element of type SC – available with various threads

Available spare parts: suction cup SPB1, connection element (Schmalz-Connector)

Available accessories: filter screen (sieve, round), suction cup insert

## Ordering Data Bellows Suction Cups SPB1 (1.5 Folds)

Type*	Part no.
SPB1 10 ED-65 M5-AG	10.01.06.03489
SPB1 10 ED-65 M5-IG	10.01.06.03568
SPB1 15 ED-65 G1/8-AG	10.01.06.03490
SPB1 15 ED-65 G1/8-IG	10.01.06.03491
SPB1 20 ED-65 G1/8-AG	10.01.06.03492
SPB1 20 ED-65 G1/8-IG	10.01.06.03493
SPB1 25 ED-65 G1/8-AG	10.01.06.03494
SPB1 25 ED-65 G1/8-IG	10.01.06.03495
SPB1 30 ED-65 G1/8-AG	10.01.06.03496
SPB1 30 ED-65 G1/8-IG	10.01.06.03497
SPB1 40 ED-65 G1/4-AG	10.01.06.03498
SPB1 40 ED-65 G1/4-IG	10.01.06.03499
SPB1 50 ED-65 G1/4-AG	10.01.06.03500
SPB1 50 ED-65 G1/4-IG	10.01.06.03501
SPB1 60 ED-65 G1/4-AG	10.01.06.03502
SPB1 60 ED-65 G1/4-IG	10.01.06.03503
SPB1 80 ED-65 G1/4-AG	10.01.06.03504
SPB1 80 ED-65 G1/4-IG	10.01.06.03505

\*Additional material specifications at beginning of the section "Vacuum Suction Cups"

Schmalz – The Company  
 Vacuum Suction Cups  
 Special Grippers  
 Gripping Systems  
 Clamping Systems  
 Mounting Elements  
 Vacuum Generators  
 Valve Technology  
 Switches and Monitoring  
 Filters and Connections  
 Services  
 Contact  
 Glossary  
 Index of Products

# Bellows Suction Cups SPB1 (1.5 Folds)

Suction area (Ø) from 10 mm to 80 mm



## Ordering Data Spare Parts Bellows Suction Cups SPB1 (1.5 Folds)

Type*	Spare Parts		Part no.
SPB1 10	Bellows suction cup (round)	SPB1 10 ED-65 SC030	10.01.06.02782
SPB1 15	Bellows suction cup (round)	SPB1 15 ED-65 SC040	10.01.06.02783
SPB1 20	Bellows suction cup (round)	SPB1 20 ED-65 SC040	10.01.06.02452
SPB1 25	Bellows suction cup (round)	SPB1 25 ED-65 SC040	10.01.06.02453
SPB1 30	Bellows suction cup (round)	SPB1 30 ED-65 SC040	10.01.06.02454
SPB1 40	Bellows suction cup (round)	SPB1 40 ED-65 SC050	10.01.06.02455
SPB1 50	Bellows suction cup (round)	SPB1 50 ED-65 SC050	10.01.06.02456
SPB1 60	Bellows suction cup (round)	SPB1 60 ED-65 SC050	10.01.06.02457
SPB1 80	Bellows suction cup (round)	SPB1 80 ED-65 SC065	10.01.06.03071

\*Additional material specifications at beginning of the section "Vacuum Suction Cups"

Type*	Spare Parts		Part no.
SPB1 10 ED-65 M5-AG	Schmalz-Connector	SC 030 M5-AG	10.01.06.02802
SPB1 10 ED-65 M5-IG	Schmalz-Connector	SC 030 M5-IG	10.01.06.03440
SPB1 15 ED-65 G1/8-AG	Schmalz-Connector	SC 040 G1/8-AG	10.01.06.02490
SPB1 15 ED-65 G1/8-IG	Schmalz-Connector	SC 040 G1/8-IG	10.01.06.02482
SPB1 20 ED-65 G1/8-AG	Schmalz-Connector	SC 040 G1/8-AG	10.01.06.02490
SPB1 20 ED-65 G1/8-IG	Schmalz-Connector	SC 040 G1/8-IG	10.01.06.02482
SPB1 25 ED-65 G1/8-AG	Schmalz-Connector	SC 040 G1/8-AG	10.01.06.02490
SPB1 25 ED-65 G1/8-IG	Schmalz-Connector	SC 040 G1/8-IG	10.01.06.02482
SPB1 30 ED-65 G1/8-AG	Schmalz-Connector	SC 040 G1/8-AG	10.01.06.02490
SPB1 30 ED-65 G1/8-IG	Schmalz-Connector	SC 040 G1/8-IG	10.01.06.02482
SPB1 40 ED-65 G1/4-AG	Schmalz-Connector	SC 050 G1/4-AG	10.01.06.02487
SPB1 40 ED-65 G1/4-IG	Schmalz-Connector	SC 050 G1/4-IG	10.01.06.02488
SPB1 50 ED-65 G1/4-AG	Schmalz-Connector	SC 050 G1/4-AG	10.01.06.02487
SPB1 50 ED-65 G1/4-IG	Schmalz-Connector	SC 050 G1/4-IG	10.01.06.02488
SPB1 60 ED-65 G1/4-AG	Schmalz-Connector	SC 050 G1/4-AG	10.01.06.02487
SPB1 60 ED-65 G1/4-IG	Schmalz-Connector	SC 050 G1/4-IG	10.01.06.02488
SPB1 80 ED-65 G1/4-AG	Schmalz-Connector	SC 065 G1/4-AG L	10.01.06.03193
SPB1 80 ED-65 G1/4-IG	Schmalz-Connector	SC 065 G1/4-IG L	10.01.06.03194

\*Additional material specifications at beginning of the section "Vacuum Suction Cups"



## Ordering Data Accessories Bellows Suction Cups SPB1 (1.5 Folds)

Type	Accessories		Part no.
SPB1 10	Pad Insert PA	SPI 8 SPB1-10	10.01.06.03710
SPB1 15	Pad Insert PA	SPI 12 SPB1-15	10.01.06.03709
SPB1 20	Pad Insert PA	SPI 18 SPB1-20	10.01.06.03385
SPB1 25	Pad Insert PA	SPI 22 SPB1-25	10.01.06.03315
SPB1 30	Pad Insert PA	SPI 26 SPB1-30	10.01.06.03386
SPB1 40	Pad Insert PA	SPI 33 SPB1-40	10.01.06.03387
SPB1 50	Pad Insert PA	SPI 40 SPB1-50	10.01.06.03388
SPB1 60	-	-	-
SPB1 80	-	-	-

# Bellows Suction Cups SPB1 (1.5 Folds)

Suction area ( $\varnothing$ ) from 10 mm to 80 mm



## Ordering Data Accessories Bellows Suction Cups SPB1 (1.5 Folds)

Type	Accessories		Part no.
SPB1 10	-	-	-
SPB1 15	-	-	-
SPB1 20	Sieve, round	SIEB 11x1 MS-A2 280 0.28/0.16	10.07.01.00309
SPB1 25	Sieve, round	SIEB 11x1 MS-A2 280 0.28/0.16	10.07.01.00309
SPB1 30	Sieve, round	SIEB 11x1 MS-A2 280 0.28/0.16	10.07.01.00309
SPB1 40	Sieve, round	SIEB 17.5x0.8 MS-A2 280 0.28/0.16	10.07.01.00308
SPB1 50	Sieve, round	SIEB 17.5x0.8 MS-A2 280 0.28/0.16	10.07.01.00308
SPB1 60	Sieve, round	SIEB 17.5x0.8 MS-A2 280 0.28/0.16	10.07.01.00308
SPB1 80	Sieve, round	SIEB 32.5x0.8 MS-A2 280 0.28/0.16	10.07.01.00364



## Technical Data Bellows Suction Cups SPB1 (1.5 Folds)

Type	Suction force [N]*	Pull-off force [N]	Lateral force [N]	Volume [cm <sup>3</sup> ]	Workpiece radius min. (convex) [mm]	Hose diameter (recom.) d [mm]**
SPB1 10	1.5	4.0	2.0	0.5	5	4
SPB1 15	4.3	9.0	5.0	1.5	8	4
SPB1 20	9.9	16.2	9.8	3.2	20	4
SPB1 25	14.9	23.4	13.0	5.3	20	4
SPB1 30	20.7	30.6	15.5	8.0	35	6
SPB1 40	35.9	46.8	24.8	18.4	70	6
SPB1 50	54.7	72.7	31.2	30.2	100	6
SPB1 60	78.0	100.9	49.4	49.3	100	6
SPB1 80	166.0	200.0	59.0	98.4	150	6

\*The specified suction forces are theoretical values at a vacuum of -0.6 bar and with a smooth, dry workpiece surface - they do not include a safety factor

\*\*The recommended hose diameter refers to a hose length of approx. 2 m



## Design Data Bellows Suction Cups SPB1 (1.5 Folds)

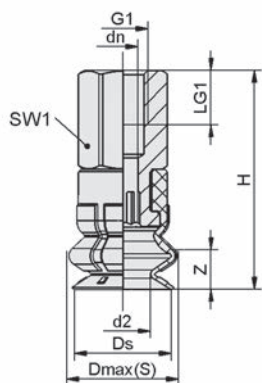

SPB1 10 - 15 IG

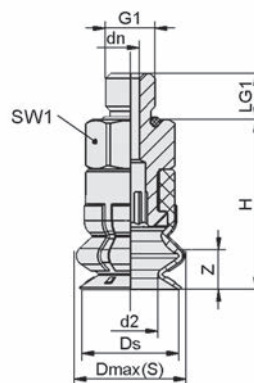

SPB1 10 - 15 AG



Schmalz - The Company  
 Vacuum Suction Cups  
 Special Grippers  
 Gripping Systems  
 Clamping Systems  
 Mounting Elements  
 Vacuum Generators  
 Valve Technology  
 Switches and Monitoring  
 Filters and Connections  
 Services  
 Contact  
 Glossary  
 Index of Products

# Bellows Suction Cups SPB1 (1.5 Folds)

Suction area (Ø) from 10 mm to 80 mm



## Design Data Bellows Suction Cups SPB1 (1.5 Folds)

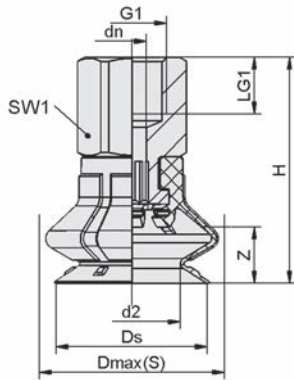

SPB1 20 - 80 IG

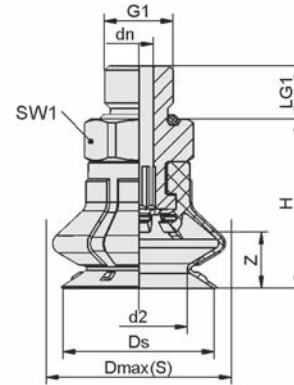

SPB1 20 - 80 AG

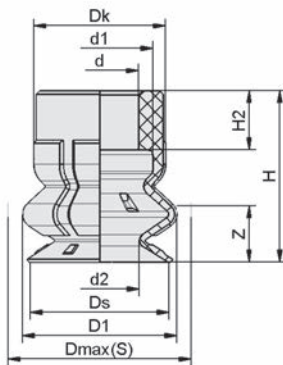

SPB1 10 - 15

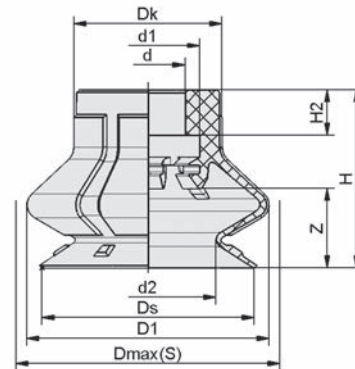

SPB1 20 - 80

Type*	dn [mm]	d2 [mm]	Dmax(S) [mm]**	Ds [mm]	G1	H [mm]	LG1 [mm]	SW1 [mm]	Z (Stroke) [mm]
SPB1 10 ED-65 M5-AG	1.8	5.6	11.3	9.8	M5-M	18	4.7	8	4
SPB1 10 ED-65 M5-IG	3.1	5.6	11.3	9.8	M5-F	23	5.5	8	4
SPB1 15 ED-65 G1/8-AG	4.1	9.5	19.7	15.4	G1/8"-M	21	7.5	14	6
SPB1 15 ED-65 G1/8-IG	4.1	9.5	19.7	15.4	G1/8"-F	29	8.0	14	6
SPB1 20 ED-65 G1/8-AG	4.1	13.8	26.3	21.4	G1/8"-M	24	7.5	14	8
SPB1 20 ED-65 G1/8-IG	4.1	13.8	26.3	21.4	G1/8"-F	32	8.0	14	8
SPB1 25 ED-65 G1/8-AG	4.1	16.9	31.3	26.4	G1/8"-M	27	7.5	14	11
SPB1 25 ED-65 G1/8-IG	4.1	16.9	31.3	26.4	G1/8"-F	35	8.0	14	11
SPB1 30 ED-65 G1/8-AG	4.1	20.0	36.7	31.4	G1/8"-M	29	7.5	14	13
SPB1 30 ED-65 G1/8-IG	4.1	20.0	36.7	31.4	G1/8"-F	37	8.0	14	13
SPB1 40 ED-65 G1/4-AG	6.1	26.1	48.0	41.4	G1/4"-M	38	10.0	17	16
SPB1 40 ED-65 G1/4-IG	6.1	26.1	48.0	41.4	G1/4"-F	48	12.0	17	16
SPB1 50 ED-65 G1/4-AG	6.1	32.3	58.4	51.4	G1/4"-M	40	10.0	17	18
SPB1 50 ED-65 G1/4-IG	6.1	32.3	58.4	51.4	G1/4"-F	50	12.0	17	18

# Bellows Suction Cups SPB1 (1.5 Folds)

Suction area ( $\emptyset$ ) from 10 mm to 80 mm

## Design Data Bellows Suction Cups SPB1 (1.5 Folds)

Type*	dn [mm]	d2 [mm]	Dmax(S) [mm]**	Ds [mm]	G1	H [mm]	LG1 [mm]	SW1 [mm]	Z (Stroke) [mm]
SPB1 60 ED-65 G1/4-AG	6.1	38.6	69.6	61.4	G1/4"-M	44	10.0	17	22
SPB1 60 ED-65 G1/4-IG	6.1	38.6	69.6	61.4	G1/4"-F	54	12.0	17	22
SPB1 80 ED-65 G1/4-AG	6.1	56.0	88.0	81.4	G1/4"-M	54	10.0	22	24
SPB1 80 ED-65 G1/4-IG	6.1	56.0	88.0	81.4	G1/4"-F	64	12.0	22	24

\*Acceptable dimensional tolerances for rubber parts concerning to DIN ISO 3302-1 M3

\*\*External dimension of the suction cup when it is pressed against the workpiece by the vacuum

Type*	d [mm]	d1 [mm]	d2 [mm]	D1 [mm]	Dk [mm]	Dmax(S) [mm]**	Ds [mm]	H [mm]	H2 [mm]	Z (Stroke) [mm]
SPB1 10	5.5	7.5	5.6	11.0	9.4	11.3	9.8	12.1	4.2	4.0
SPB1 15	7.5	10.5	9.5	18.4	15.1	19.7	15.4	15.0	4.6	6.0
SPB1 20	7.5	10.5	13.8	24.6	15.1	26.3	21.4	18.0	4.6	8.0
SPB1 25	7.5	10.5	16.9	29.0	15.1	31.3	26.4	21.0	4.6	11.0
SPB1 30	7.5	10.5	20.0	34.2	15.1	36.7	31.4	23.0	4.6	13.0
SPB1 40	11.0	17.5	26.1	44.6	21.6	48.0	41.4	30.0	7.0	16.0
SPB1 50	11.0	17.5	32.3	55.2	21.6	58.4	51.4	32.0	7.0	18.0
SPB1 60	11.0	17.5	38.6	65.7	21.6	69.6	61.4	36.0	7.0	22.0
SPB1 80	14.0	29.3	56.0	82.7	27.1	88.0	81.4	45.9	15.3	23.5

\*Acceptable dimensional tolerances for rubber parts concerning to DIN ISO 3302-1 M3

\*\*External dimension of the suction cup when it is pressed against the workpiece by the vacuum



# Bellows Suction Cups SPOB1 (Oval, 1.5 Folds)

Suction area (LxW) from 60 x 20 mm and 100 x 40 mm



## Suitability for Industry Specific Applications

Schmalz – The Company  
Vacuum Suction Cups

Special Grippers

Gripping Systems

Clamping Systems

Mounting Elements

Vacuum Generators

Valve Technology

Switches and Monitoring

Filters and Connections

Services

Contact

Glossary

Index of Products



Bellows Suction Cups SPOB1 (Oval, 1.5 Folds)

## Applications

- Oval, bellows suction cup with 1.5 folds for the use in cardboard box and tray erectors
- Handling of cardboard and rigid or flexible packaging in top-loading and side-loading machines
- Palletizing and depalletizing processes
- Heavy-duty applications that require suction cups with excellent sealing and low wear

## Design

- Oval, bellows suction cup SPOB1 with 1.5 folds (1) and soft, flexible sealing lip
- Made of wear-proof material Elastodur ED-65 with a long service life
- All sizes come with a 2-piece connection element: consisting of machine-side component (2) and suction-side component (3)
- Size 100 x 40 mm with additional suction cup insert (4); included in scope of delivery reusable connection elements
- Clip-in filter screen (5) as pre-filter (filter pore size 250 µm)

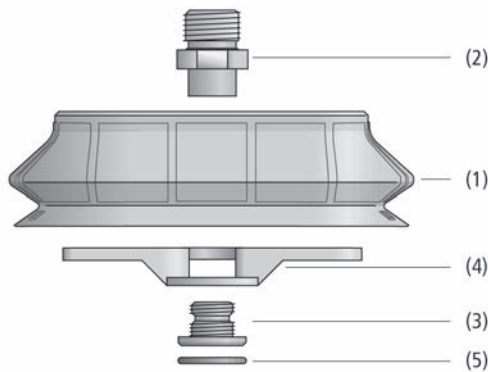

System Design Bellows Suction Cups SPOB1 (Oval, 1.5 Folds)



Bellows suction cups SPOB1 being used for handling of cardboard

## Our Highlights...

- Oval shape
- Suction cup features robust, reinforced main body
- Interlocking of sealing-lip and fold due to locking elements
- Made from wear-proof and abrasion-proof material Elastodur ED-65

## Your Benefits...

- Ideal for all oblong workpieces
- High intrinsic stability of the suction cup in dynamic processes
- Form-locking connection to avoid sliding of the suction cup
- Very low wear; service life approx. 3 times higher compared to NBR



# Bellows Suction Cups SPOB1 (Oval, 1.5 Folds)

Suction area (LxW) from 60 x 20 mm and 100 x 40 mm

## Designation Code Bellows Suction Cups SPOB1 (Oval, 1.5 Folds)

<b>SPOB1</b>	-	<b>60x20</b>	-	<b>ED-65</b>	-	<b>G1/8-AG</b>
1		2		3		4

### 1 – Abbreviated designation

Code	Version
SPOB1	1.5 folds, oval

### 2 – Suction area

Code	LxW in mm
60x20...100x40	60x20 and 100x40

### 3 – Material

Code	Material
ED-65	Elastodur

### 4 – Connection

Code	Connection
G1/4-AG	G1/4-AG (AG = male (M))
G1/4-IG	G1/4-IG (IG = female (F))
G1/8-AG	G1/8-AG
G1/8-IG	G1/8-IG

Suction cup SPOB1 (elastomer part + connection element) is delivered assembled.

The assembly consists of:

- Suction cup of type SPOB1 – elastomer part, available in various diameters
- Connection element of type SC – available with various threads, includes stabilization plate for model size 100 x 400 mm

Available spare parts: suction cup SPOB1, Schmalz-Connector

Available accessories: filter screen (sieve, round)

## Ordering Data Bellows Suction Cups SPOB1 (Oval, 1.5 Folds)

Type*	Part no.
SPOB1 60x20 ED-65 G1/8-AG	10.01.06.03510
SPOB1 60x20 ED-65 G1/8-IG	10.01.06.03511
SPOB1 100x40 ED-65 G1/4-AG	10.01.06.03512
SPOB1 100x40 ED-65 G1/4-IG	10.01.06.03513

\*Additional material specifications at beginning of the section "Vacuum Suction Cups"

## Ordering Data Spare Parts Bellows Suction Cups SPOB1 (Oval, 1.5 Folds)

Type	Spare Parts	Part no.
SPOB1 60x20	Bellows suction cup (oval)	SPOB1 60x20 ED-65 SC040-AR 10.01.06.02462
SPOB1 100x40	Bellows suction cup (oval)	SPOB1 100x40 ED-65 SC050 10.01.06.02461

Type	Spare Parts	Part no.
SPOB1 60x20 ED-65 G1/8-AG	Schmalz-Connector	SC 040-AR G1/8-AG 10.01.06.02495
SPOB1 60x20 ED-65 G1/8-IG	Schmalz-Connector	SC 040-AR G1/8-IG 10.01.06.02496
SPOB1 100x40 ED-65 G1/4-AG	Schmalz-Connector	SC 050-AR G1/4-AG 10.01.06.02491
SPOB1 100x40 ED-65 G1/4-IG	Schmalz-Connector	SC 050-AR G1/4-IG 10.01.06.02493

# Bellows Suction Cups SPOB1 (Oval, 1.5 Folds)

Suction area (LxW) from 60 x 20 mm and 100 x 40 mm



## Ordering Data Accessories Bellows Suction Cups SPOB1 (Oval, 1.5 Folds)

Type	Accessories	Part no.
SPOB1 60x20	Sieve, round	SIEB 11x1 MS-A2 280 0.28/0.16
SPOB1 100x40	Sieve, round	SIEB 17.5x0.8 MS-A2 280 0.28/0.16



## Technical Data Bellows Suction Cups SPOB1 (Oval, 1.5 Folds)

Type	Suction force [N]*	Pull-off force [N]	Lateral force [N]	Volume [cm³]	Workpiece radius min. (convex) [mm]	Hose diameter (recom.) d [mm]**
SPOB1 60x20	32.5	39.8	32.2	11.0	25	6
SPOB1 100x40	111.2	131.4	76.9	60.1	50	6

\*The specified suction forces are theoretical values at a vacuum of -0.6 bar and with a smooth, dry workpiece surface - they do not include a safety factor

\*\*The recommended hose diameter refers to a hose length of approx. 2 m



## Design Data Bellows Suction Cups SPOB1 (Oval, 1.5 Folds)

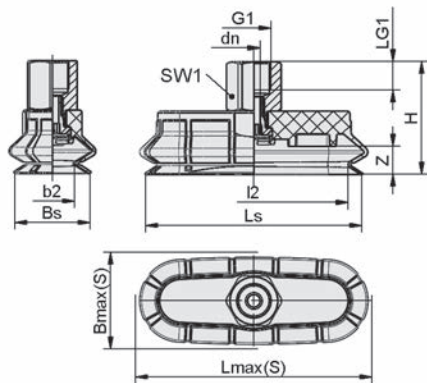

SPOB1 IG

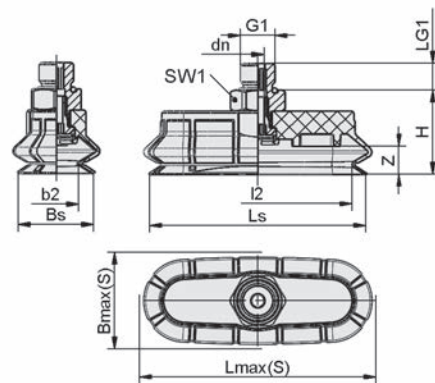

SPOB1 AG

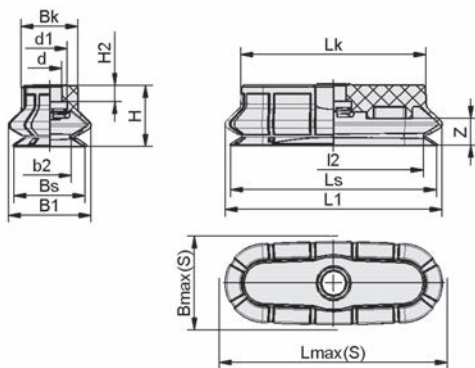

SPOB1 60x20

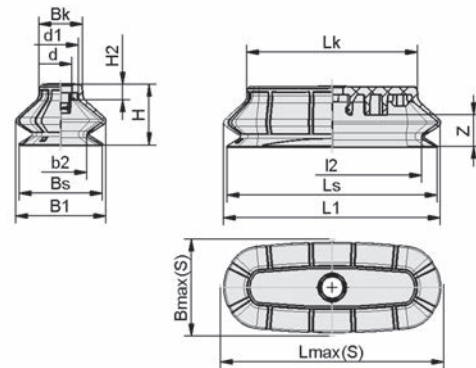

SPOB1 100x40

# Bellows Suction Cups SPOB1 (Oval, 1.5 Folds)

Suction area (LxW) from 60 x 20 mm and 100 x 40 mm



## Design Data Bellows Suction Cups SPOB1 (Oval, 1.5 Folds)

Type*	b2 [mm]	Bmax(S) [mm]**	Bs [mm]	dn [mm]	G1	H [mm]	LG1 [mm]	Lmax(S) [mm]***	Ls [mm]	I2 [mm]	SW1 [mm]	Z (Stroke) [mm]
SPOB1 60x20 ED-65 G1/8-AG	12.8	27.5	21.4	3.6	G1/8"-M	24	7.5	67	61.4	53.5	14	8
SPOB1 60x20 ED-65 G1/8-IG	12.8	27.5	21.4	3.6	G1/8"-F	32	8.0	67	61.4	53.5	14	8
SPOB1 100x40 ED-65 G1/4-AG	25.9	52.0	41.4	6.1	G1/4"-M	37	10.0	113	104.4	88.9	17	16
SPOB1 100x40 ED-65 G1/4-IG	25.9	52.0	41.4	6.1	G1/4"-F	47	12.0	113	104.4	88.9	17	16

\*Acceptable dimensional tolerances for rubber parts concerning to DIN ISO 3302-1 M3

\*\*External dimension of the suction cup when it is pressed against the workpiece by the vacuum

\*\*\*External dimension of the suction cup when it is pressed against the workpiece by the vacuum

Type*	b2 [mm]	B1 [mm]	Bk [mm]	Bmax(S) [mm]**	Bs [mm]	d [mm]	d1 [mm]	H [mm]	H2 [mm]	L1 [mm]	I2 [mm]	Lk [mm]	Lmax(S) [mm]***	Ls [mm]	Z (Stroke) [mm]
SPOB1 60x20 ED-65 SC040-AR	12.8	24.6	16.8	27.5	21.4	7.3	10.5	18	4.8	64.6	53.4	55.1	67	61.4	8.0
SPOB1 100x40 ED-65 SC050	25.9	44.6	21.6	52.0	41.4	11.0	17.5	30	7.0	107.6	88.9	84.6	113	104.4	16.0

\*Acceptable dimensional tolerances for rubber parts concerning to DIN ISO 3302-1 M3

\*\*External dimension of the suction cup when it is pressed against the workpiece by the vacuum

\*\*\*External dimension of the suction cup when it is pressed against the workpiece by the vacuum

# Bellows Suction Cups SPB2 (2.5 Folds)

Suction area (Ø) from 20 mm to 50 mm



## Suitability for Industry Specific Applications



Bellows Suction Cups SPB2 (2.5 Folds)

## Applications

- Round bellows suction cups with 2.5 folds for use in carton and tray erectors with high demands on suction cup stroke, dynamics and wear resistance
- Handling of non-rigid workpieces such as filled cardboard boxes for palletizing and depalletizing processes
- Applications which require high adaptability and high height compensation, such as taking cartons from a magazine in rotary erectors
- Handling of cardboard, inherently stable and flexible packaging in top-loading and side-loading machines

## Design

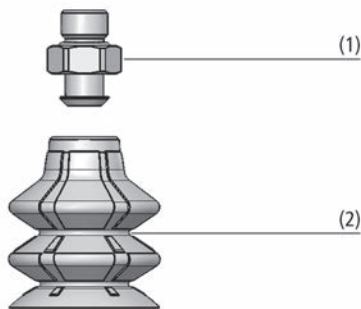

System Design Bellows Suction Cups SPB2 (2.5 Folds)

- Round bellows suction cup SPB2 with 2.5 folds (2) and flexible sealing lip
- Diameter up to 30 mm with a one-piece plug-in connection element (1)
- From diameter 40 mm with two-piece connection element: consisting of machine-side component and suction cup-side component
- Available as mounted suction cup consisting of connection element and suction cup or as individual parts

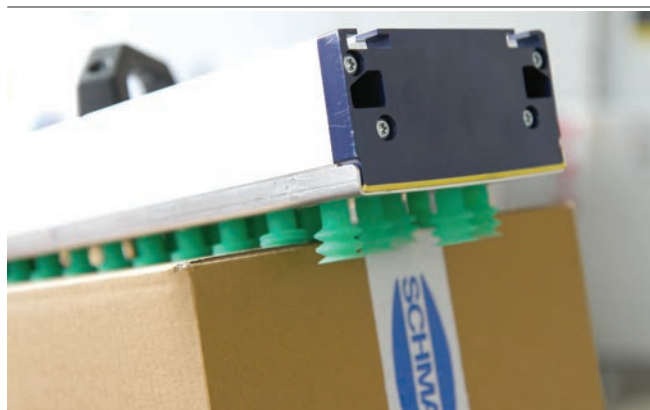

Bellows suction cups SPB2 being used for handling of cardboard boxes

## Our Highlights...

- High suction cup stroke
- Large inner fold diameters
- Flexible, adaptable sealing lip
- Locking elements between sealing lip and fold

## Your Benefits...

- Good adaptability and height adjustment on curved surfaces
- High volume flow rates and short cycle times
- Good sealing on cardboard and rigid packaging
- Gearing prevents shifting of suction cup

# Bellows Suction Cups SPB2 (2.5 Folds)

Suction area (Ø) from 20 mm to 50 mm

## Designation Code Bellows Suction Cups SPB2 (2.5 Folds)

<b>SPB2</b>	-	<b>30</b>	-	<b>ED-65</b>	-	<b>G1/8-AG</b>
<b>1</b>		<b>2</b>		<b>3</b>		<b>4</b>

### 1 – Abbreviated designation

Code	Version
SPB2	2.5 folds

### 2 – Suction area

Code	Diameter in mm
20...50	ø 20 to 50

### 3 – Material

Code	Material
ED-65	Elastodur

### 4 – Connection

Code	Connection
G1/4-AG	G1/4-AG (AG = male (M))
G1/4-IG	G1/4-IG (IG = female (F))
G1/8-AG	G1/8-AG
G1/8-IG	G1/8-IG

Suction cup SPB2 (elastomer part + connection element) is delivered assembled. The assembly consists of:

- Suction cup of type SPB2 - elastomer part, available in various diameters
- Connection element of type SC - available with various threads

Available spare parts: suction cup SPB2, connection element (Schmalz-Connector)

Available accessories: pad insert SPI

## Ordering Data Bellows Suction Cups SPB2 (2.5 Folds)

Type	Vacuum connection:			
	G1/4-AG	G1/4-IG	G1/8-AG	G1/8-IG
SPB2 20	-	-	10.01.06.03453	10.01.06.03454
SPB2 25	-	-	10.01.06.03455	10.01.06.03456
SPB2 30	-	-	10.01.06.03457	10.01.06.03458
SPB2 40	10.01.06.03459	10.01.06.03460	-	-
SPB2 50	10.01.06.03461	10.01.06.03462	-	-

## Ordering Data Spare Parts Bellows Suction Cups SPB2 (2.5 Folds)

Type	Spare Parts		Part no.
SPB2 20	Bellows suction cup (round)	SPB2 20 ED-65 SC040	10.01.06.03409
SPB2 25	Bellows suction cup (round)	SPB2 25 ED-65 SC040	10.01.06.03410
SPB2 30	Bellows suction cup (round)	SPB2 30 ED-65 SC040	10.01.06.03411
SPB2 40	Bellows suction cup (round)	SPB2 40 ED-65 SC050	10.01.06.03412
SPB2 50	Bellows suction cup (round)	SPB2 50 ED-65 SC050	10.01.06.03413

Type	Spare Parts		Part no.
SPB2 20 ED-65 G1/8-AG	Schmalz-Connector	SC 040 G1/8-AG	10.01.06.02490
SPB2 20 ED-65 G1/8-IG	Schmalz-Connector	SC 040 G1/8-IG	10.01.06.02482
SPB2 25 ED-65 G1/8-AG	Schmalz-Connector	SC 040 G1/8-AG	10.01.06.02490
SPB2 25 ED-65 G1/8-IG	Schmalz-Connector	SC 040 G1/8-IG	10.01.06.02482
SPB2 30 ED-65 G1/8-AG	Schmalz-Connector	SC 040 G1/8-AG	10.01.06.02490
SPB2 30 ED-65 G1/8-IG	Schmalz-Connector	SC 040 G1/8-IG	10.01.06.02482

# Bellows Suction Cups SPB2 (2.5 Folds)

Suction area (Ø) from 20 mm to 50 mm



## Ordering Data Spare Parts Bellows Suction Cups SPB2 (2.5 Folds)

Type	Spare Parts		Part no.
SPB2 40 ED-65 G1/4-AG	Schmalz-Connector	SC 050 G1/4-AG	10.01.06.02487
SPB2 40 ED-65 G1/4-IG	Schmalz-Connector	SC 050 G1/4-IG	10.01.06.02488
SPB2 50 ED-65 G1/4-AG	Schmalz-Connector	SC 050 G1/4-AG	10.01.06.02487
SPB2 50 ED-65 G1/4-IG	Schmalz-Connector	SC 050 G1/4-IG	10.01.06.02488



## Ordering Data Accessories Bellows Suction Cups SPB2 (2.5 Folds)

Type	Accessories		Part no.
SPB2 20	Pad Insert PA	SPI 20 SPB2-20	10.01.06.04041
SPB2 25	Pad Insert PA	SPI 25 SPB2-25	10.01.06.04042
SPB2 30	Pad Insert PA	SPI 30 SPB2-30	10.01.06.04043
SPB2 40	Pad Insert PA	SPI 40 SPB2-40	10.01.06.04044
SPB2 50	Pad Insert PA	SPI 50 SPB2-50	10.01.06.04045



## Technical Data Bellows Suction Cups SPB2 (2.5 Folds)

Type	Suction force [N]*	Pull-off force [N]	Lateral force [N]	Volume [cm³]	Workpiece radius min. (convex) [mm]	Hose diameter (recom.) d [mm]**
SPB2 20	6.8	15.7	8.4	4.2	20	4
SPB2 25	9.9	20.1	9.1	7.6	20	4
SPB2 30	14.4	28.4	12.8	12.4	30	6
SPB2 40	24.8	40.5	20.3	27.9	60	6
SPB2 50	34.6	61.8	28.5	51.8	75	6

\*The specified suction forces are theoretical values at a vacuum of -0.6 bar and with a smooth, dry workpiece surface - they do not include a safety factor

\*\*The recommended hose diameter refers to a hose length of approx. 2 m



## Design Data Bellows Suction Cups SPB2 (2.5 Folds)

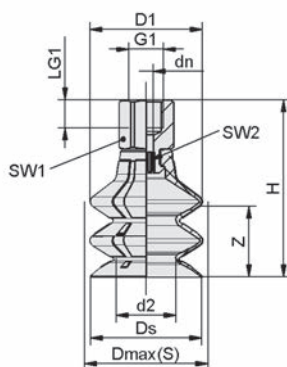

SPB2 IG

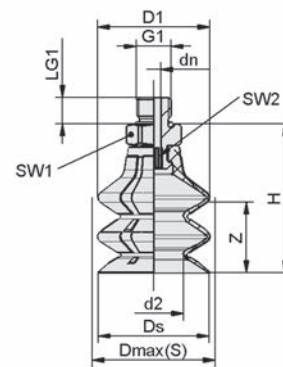

SPB2 AG

Schmalz – The Company  
 Vacuum Suction Cups  
 Special Grippers  
 Gripping Systems  
 Clamping Systems  
 Mounting Elements  
 Vacuum Generators  
 Valve Technology  
 Switches and Monitoring  
 Filters and Connections  
 Services  
 Contact  
 Glossary  
 Index of Products

# Bellows Suction Cups SPB2 (2.5 Folds)

Suction area (Ø) from 20 mm to 50 mm

## Design Data Bellows Suction Cups SPB2 (2.5 Folds)

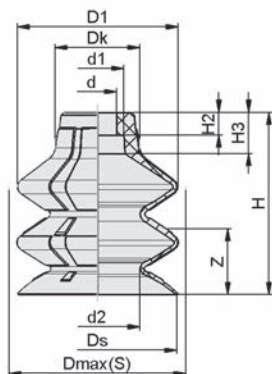

SPB2

Type*	d2 [mm]	dn [mm]	D1 [mm]	Dmax(S) [mm]**	Ds [mm]	G1	H [mm]	LG1 [mm]	SW1 [mm]	SW2 [mm]	Z (Stroke) [mm]
SPB2 20 ED-65 G1/8-AG	12.0	4.0	22.1	23.5	21.4	G1/8"-M	32	7.5	14	4	13
SPB2 20 ED-65 G1/8-IG	12.0	4.0	22.1	23.5	21.4	G1/8"-F	40	8.0	14	4	13
SPB2 25 ED-65 G1/8-AG	14.5	4.0	27.2	28.0	26.4	G1/8"-M	37	7.5	14	4	17
SPB2 25 ED-65 G1/8-IG	14.5	4.0	27.2	28.0	26.4	G1/8"-F	45	8.0	14	4	17
SPB2 30 ED-65 G1/8-AG	16.9	4.0	32.2	34.0	31.4	G1/8"-M	43	7.5	14	4	20
SPB2 30 ED-65 G1/8-IG	16.9	4.0	32.2	34.0	31.4	G1/8"-F	51	8.0	14	4	20
SPB2 40 ED-65 G1/4-AG	22.9	6.1	42.2	44.5	41.3	G1/4"-M	53	10.0	17	6	25
SPB2 40 ED-65 G1/4-IG	22.9	6.1	42.2	44.5	41.3	G1/4"-F	63	12.0	17	6	25
SPB2 50 ED-65 G1/4-AG	27.1	6.1	52.2	55.5	51.3	G1/4"-M	64	10.0	17	6	32
SPB2 50 ED-65 G1/4-IG	27.1	6.1	52.2	55.5	51.3	G1/4"-F	74	12.0	17	6	32

\*Acceptable dimensional tolerances for rubber parts concerning to DIN ISO 3302-1 M3

\*\*External dimension of the suction cup when it is pressed against the workpiece by the vacuum

Type*	d [mm]	d1 [mm]	d2 [mm]	D1 [mm]	Dk [mm]	Dmax(S) [mm]**	Ds [mm]	H [mm]	H2 [mm]	H3 [mm]	Z (Stroke) [mm]
SPB2 20	7.5	10.5	12.0	22.2	15.0	23.5	21.4	25.3	4.6	7.0	13.0
SPB2 25	7.5	10.5	14.5	27.2	15.5	28.0	26.4	30.9	4.6	7.8	17.0
SPB2 30	7.5	10.5	16.9	32.2	16.8	34.0	31.4	36.2	4.6	7.9	20.0
SPB2 40	11.0	17.3	22.9	42.2	22.5	44.5	41.3	45.0	7.0	9.9	25.0
SPB2 50	11.0	17.3	27.1	52.2	23.5	55.5	51.3	55.9	7.0	11.6	32.0

\*Acceptable dimensional tolerances for rubber parts concerning to DIN ISO 3302-1 M3

\*\*External dimension of the suction cup when it is pressed against the workpiece by the vacuum

Schmalz - The Company  
Vacuum Suction Cups  
Special Grippers  
Gripping Systems  
Clamping Systems  
Mounting Elements  
Vacuum Generators  
Valve Technology  
Switches and Monitoring  
Filters and Connections  
Services  
Contact  
Glossary  
Index of Products



# Bellows Suction Cups SPB2 P (2.5 Folds) Flow Restrictor

Suction area (Ø) 20 mm and 40 mm



Bellows Suction Cups SPB2 P (2.5 Folds) Flow Restrictor

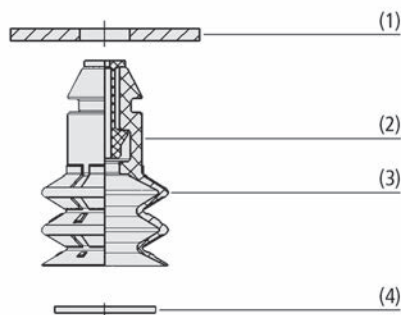

System Design Bellows Suction Cups SPB2 P (2.5 Folds) Flow Restrictor

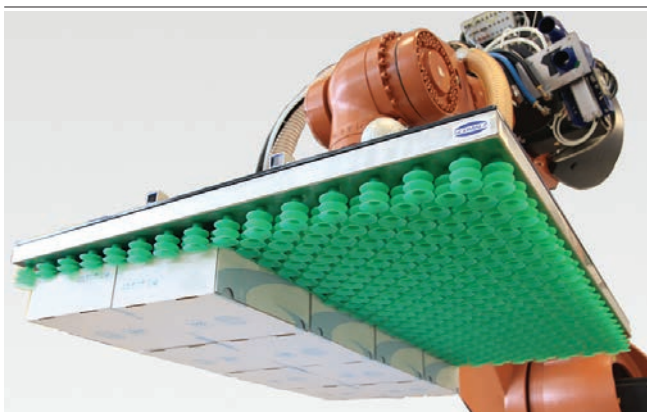

Bellows suction cups SPB2 P being used for handling of cardboard boxes

## Suitability for Industry Specific Applications

### Applications

- Round bellows suction cup with 2.5 folds used for palletizing and depalletizing processes in the packaging industry
- Handling of packaging materials such as cardboard boxes, rigid and flexible packaging
- Handling of blister packaging, shrink-wrapped products, plastic bags or trays
- Used in area gripping systems and "suction cup carpets"; integrated flow restrictor to reduce leakage occurring at partial occupancy

### Design

- Round bellows suction cup SPB2 P with 2.5 folds (3) and soft, flexible sealing lip
- Integrated flow restrictor (2) with diameters from 0.8 to 1.5 mm
- Tool free assembly directly in an existing drill hole (1) due to push-in function (2)
- Optional integration of filter screen (4) as a pre-filter (120 µm filter pore size)

### Our Highlights...

- Tool-free installation due to push-in function
- Flexible, adaptable sealing lip
- Soft bellows with a large stroke and low restoring force
- Food grade material Silicone SI (FDA conform)

### Your Benefits...

- Quick installation and removal of the suction cups
- Optimal sealing on cardboard boxes and packaging material
- Used in area gripping systems and "suction cup carpets"
- Direct use in the food industry possible

Schmalz – The Company

Vacuum Suction Cups

Special Grippers

Gripping Systems

Clamping Systems

Mounting Elements

Vacuum Generators

Valve Technology

Switches and Monitoring

Filters and Connections

Services

Contact

Glossary

Index of Products



# Bellows Suction Cups SPB2 P (2.5 Folds) Flow Restrictor

Suction area (Ø) 20 mm and 40 mm



## Designation Code Bellows Suction Cups SPB2 P (2.5 Folds) Flow Restrictor



### 1 – Abbreviated designation

Code	Version
SPB2	2.5 folds

### 2 – Suction area

Code	Diameter in mm
20...40	ø 20 and 40

### 3 – Material

Code	Material
SI-40	Silicone
SI-55	Silicone

### 4 – Flow restrictor

Code	Diameter in mm
SW80	ø 0.8
SW100	ø 1
SW130	ø 1.3
SW150	ø 1.5

### 5 – Product addition

Code	Type
P	Push-in function

Bellows suction cup SPB2 P is delivered as a ready-to-connect component. Available in different diameters.

Available spare parts: suction cup SPB2 P, flow restrictor

Available accessories: filter disc



## Ordering Data Bellows Suction Cups SPB2 P (2.5 Folds) Flow Restrictor

Type	Part no.
SPB2 20 SI-40 SW80 P	10.01.06.03220
SPB2 20 SI-40 SW100 P	10.01.06.03221
SPB2 20 SI-40 SW130 P	10.01.06.03222
SPB2 20 SI-40 SW150 P	10.01.06.03223
SPB2 40 SI-55 SW80 P	10.01.06.03224
SPB2 40 SI-55 SW100 P	10.01.06.03225
SPB2 40 SI-55 SW130 P	10.01.06.03226
SPB2 40 SI-55 SW150 P	10.01.06.03227



## Ordering Data Spare Parts Bellows Suction Cups SPB2 P (2.5 Folds) Flow Restrictor

Type	Spare Parts		Part no.
SPB2 20 SI-40 SW80 P	Bellows suction cup (round)	SPB2 20 SI-40 P	10.01.06.03125
SPB2 20 SI-40 SW100 P	Bellows suction cup (round)	SPB2 20 SI-40 P	10.01.06.03125
SPB2 20 SI-40 SW130 P	Bellows suction cup (round)	SPB2 20 SI-40 P	10.01.06.03125
SPB2 20 SI-40 SW150 P	Bellows suction cup (round)	SPB2 20 SI-40 P	10.01.06.03125
SPB2 40 SI-55 SW80 P	Bellows suction cup (round)	SPB2 40 SI-55 P	10.01.06.03126
SPB2 40 SI-55 SW100 P	Bellows suction cup (round)	SPB2 40 SI-55 P	10.01.06.03126
SPB2 40 SI-55 SW130 P	Bellows suction cup (round)	SPB2 40 SI-55 P	10.01.06.03126
SPB2 40 SI-55 SW150 P	Bellows suction cup (round)	SPB2 40 SI-55 P	10.01.06.03126

Type	SW 80 P	SW 100 P	SW 130 P	SW 150 P
SPB2 0.8	10.05.04.00090	-	-	-
SPB2 1.0	-	10.05.04.00091	-	-
SPB2 1.3	-	-	10.05.04.00092	-
SPB2 1.5	-	-	-	10.05.04.00093



# Bellows Suction Cups SPB2 P (2.5 Folds) Flow Restrictor

Suction area (Ø) 20 mm and 40 mm



## Ordering Data Accessories Bellows Suction Cups SPB2 P (2.5 Folds) Flow Restrictor

Type	Accessories		Part no.
SPB2 20	Filter disc	FD 16 120	10.01.06.02565
SPB2 40	Filter disc	FD 34 120	10.01.06.02572



## Technical Data Bellows Suction Cups SPB2 P (2.5 Folds) Flow Restrictor

Type	Suction force [N]*	Pull-off force [N]	Workpiece radius min. (convex) [mm]	Volume [cm <sup>3</sup> ]
SPB2 20	4.9	8	25	2.5
SPB2 40	14.9	40	75	22.0

\*The specified suction forces are theoretical values at a vacuum of -0.6 bar and with a smooth, dry workpiece surface - they do not include a safety factor



## Design Data Bellows Suction Cups SPB2 P (2.5 Folds) Flow Restrictor

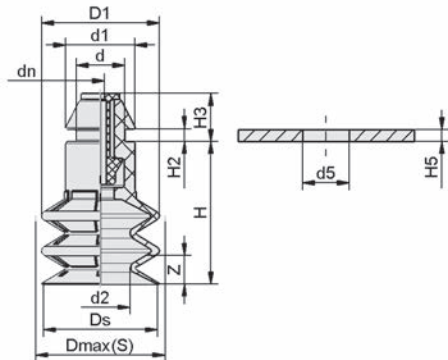

SPB2 P

Type*	d [mm]	d1 [mm]	d2 [mm]	d5 [mm]	D1 [mm]	Dmax(S) [mm]**	dn [mm]	Ds [mm]	H [mm]	H2 [mm]	H3 [mm]	H5 [mm]	Z (Stroke) [mm]	
SPB2 20	0.8	8.5	11.8	10.2	7.9	20.0	20.5	0.8	19.6	24.3	2.2	8.2	2	9
SPB2 20	1	8.5	11.8	10.2	7.9	20.0	20.5	1.0	19.6	24.3	2.2	8.2	2	9
SPB2 20	1.3	8.5	11.8	10.2	7.9	20.0	20.5	1.3	19.6	24.3	2.2	8.2	2	9
SPB2 20	1.5	8.5	11.8	10.2	7.9	20.0	20.5	1.5	19.6	24.3	2.2	8.2	2	9
SPB2 40	0.8	12.5	15.7	17.8	11.5	43.5	44.6	0.8	42.7	47.0	2.2	8.2	2	20
SPB2 40	1	12.5	15.7	17.8	11.5	43.5	44.6	1.0	42.7	47.0	2.2	8.2	2	20
SPB2 40	1.3	12.5	15.7	17.8	11.5	43.5	44.6	1.3	42.7	47.0	2.2	8.2	2	20
SPB2 40	1.5	12.5	15.7	17.8	11.5	43.5	44.6	1.5	42.7	47.0	2.2	8.2	2	20

\*Acceptable dimensional tolerances for rubber parts concerning to DIN ISO 3302-1 M3

\*\*External dimension of the suction cup when it is pressed against the workpiece by the vacuum



## Bellows Suction Cups SPB4 (4.5 Folds)

Suction area (Ø) from 20 mm to 50 mm



### Suitability for Industry Specific Applications

#### Applications

- Round, bellows suction cup with 4.5 folds for handling of flexible products such as pouches and other plastic film packaging
- Process reliable gripping and handling of solid, powdery and liquid filled pouches
- High-speed packaging processes, particularly in conjunction with parallel kinematic robots



Bellows Suction Cups SPB4 (4.5 Folds)

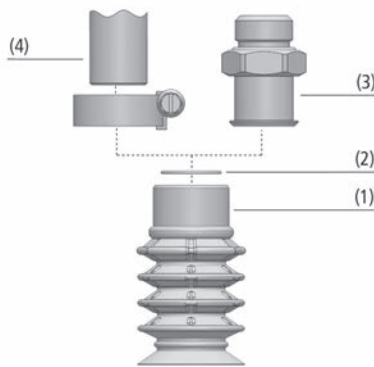

System Design Bellows Suction Cups SPB4 (4.5 Folds)

#### Design

- Bellows suction cup SPB4 (1) with 4.5 folds and soft, flexible sealing lip
- Special reinforced bellows for additional stability
- Mounting via Schmalz Connector SC (3). Alternatively direct attachment on pipe via hose clamp (4)
- All mounting elements with male thread include an integrated sealing ring
- Optional pre-filter (2) (250 µm filter pore size)
- Optional insert disc SPI for the lower suction fold avoids taping the foil



Bellows suction cups SPB4 being used for handling foil-wrapped products

#### Our Highlights...

- Thin, steep sealing lip with flow fins
- Functional separation of folds and sealing lip
- Reinforced basic body and folds
- Food grade material Silicone SI (FDA conform)

#### Your Benefits...

- Extraordinary sealing on pouches and other flexible materials
- Compressed bellows have no negative effect on flexibility of sealing lip
- No collapsing when suction cup is stretched under vacuum
- Suitable for applications in the food industry

# Bellows Suction Cups SPB4 (4.5 Folds)

Suction area (Ø) from 20 mm to 50 mm



## Designation Code Bellows Suction Cups SPB4 (4.5 Folds)

<b>SPB4</b>	-	<b>30</b>	-	<b>SI-55</b>	-	<b>G1/4-AG</b>
<b>1</b>		<b>2</b>		<b>3</b>		<b>4</b>

### 1 – Abbreviated designation

Code	Version
SPB4	4.5 folds

### 2 – Suction area

Code	Diameter in mm
20...50	ø 20 to 50

### 3 – Material

Code	Material
SI-55	Silicone

### 4 – Connection

Code	Connection
G1/8-AG	G1/8-AG (AG = male (M))
G1/8-IG	G1/8-IG (IG = female (F))
G1/4-AG	G1/4-AG
G1/4-IG	G1/4-IG
G3/8-AG	G3/8-AG
G3/8-IG	G3/8-IG
G1/2-AG	G1/2-AG
G1/2-IG	G1/2-IG

Suction cup SPB4 (elastomer part + connection element) is delivered assembled. The assembly consists of:

- Suction cup of type SPB4 – elastomer part, available in various diameters
- Connection element of type SC – available with various threads

Available spare parts: suction cup SPB4, connection element (Schmalz-Connector)

Available accessories: filter screen (sieve, round), hose clamp, pad insert



## Ordering Data Bellows Suction Cups SPB4 (4.5 Folds)

Type		Vacuum connection:							
		G1/8-AG	G1/8-IG	G1/4-AG	G1/4-IG	G3/8-AG	G3/8-IG	G1/2-AG	G1/2-IG
SPB4	20	10.01.06.03514	10.01.06.03517	10.01.06.03515	10.01.06.03518	10.01.06.03516	10.01.06.03519	-	-
SPB4	30	10.01.06.03520	10.01.06.03523	10.01.06.03521	10.01.06.03524	10.01.06.03522	10.01.06.03525	-	-
SPB4	40	10.01.06.03913	10.01.06.03914	10.01.06.03526	10.01.06.03529	10.01.06.03527	10.01.06.03530	10.01.06.03528	10.01.06.03531
SPB4	50	10.01.06.03915	10.01.06.03916	10.01.06.03532	10.01.06.03535	10.01.06.03533	10.01.06.03536	10.01.06.03534	10.01.06.03537



## Ordering Data Spare Parts Bellows Suction Cups SPB4 (4.5 Folds)

Type		Spare Parts	Part no.
SPB4	20	Bellows suction cup (round)	SPB4 20 SI-55 SC080 10.01.06.02588
SPB4	30	Bellows suction cup (round)	SPB4 30 SI-55 SC080 10.01.06.02589
SPB4	40	Bellows suction cup (round)	SPB4 40 SI-55 SC090 10.01.06.02590
SPB4	50	Bellows suction cup (round)	SPB4 50 SI-55 SC090 10.01.06.02613

# Bellows Suction Cups SPB4 (4.5 Folds)

Suction area (Ø) from 20 mm to 50 mm



## Ordering Data Spare Parts Bellows Suction Cups SPB4 (4.5 Folds)

Type*	Spare Parts		Part no.
SPB4 20 SI-55 G1/8-AG	Schmalz-Connector	SC 080 G1/8-AG	10.01.06.03142
SPB4 20 SI-55 G1/8-IG	Schmalz-Connector	SC 080 G1/8-IG	10.01.06.03270
SPB4 20 SI-55 G1/4-AG	Schmalz-Connector	SC 080 G1/4-AG	10.01.06.03268
SPB4 20 SI-55 G1/4-IG	Schmalz-Connector	SC 080 G1/4-IG	10.01.06.03271
SPB4 20 SI-55 G3/8-AG	Schmalz-Connector	SC 080 G3/8-AG	10.01.06.02593
SPB4 20 SI-55 G3/8-IG	Schmalz-Connector	SC 080 G3/8-IG	10.01.06.02594
SPB4 30 SI-55 G1/8-AG	Schmalz-Connector	SC 080 G1/8-AG	10.01.06.03142
SPB4 30 SI-55 G1/8-IG	Schmalz-Connector	SC 080 G1/8-IG	10.01.06.03270
SPB4 30 SI-55 G1/4-AG	Schmalz-Connector	SC 080 G1/4-AG	10.01.06.03268
SPB4 30 SI-55 G1/4-IG	Schmalz-Connector	SC 080 G1/4-IG	10.01.06.03268
SPB4 30 SI-55 G3/8-AG	Schmalz-Connector	SC 080 G3/8-AG	10.01.06.02593
SPB4 30 SI-55 G3/8-IG	Schmalz-Connector	SC 080 G3/8-IG	10.01.06.02594
SPB4 40 SI-55 G1/4-AG	Schmalz-Connector	SC 090 G1/4-AG	10.01.06.02793
SPB4 40 SI-55 G1/4-IG	Schmalz-Connector	SC 090 G1/4-IG	10.01.06.03273
SPB4 40 SI-55 G3/8-AG	Schmalz-Connector	SC 090 G3/8-AG	10.01.06.02791
SPB4 40 SI-55 G3/8-IG	Schmalz-Connector	SC 090 G3/8-IG	10.01.06.03274
SPB4 40 SI-55 G1/2-AG	Schmalz-Connector	SC 090 G1/2-AG	10.01.06.02595
SPB4 40 SI-55 G1/2-IG	Schmalz-Connector	SC 090 G1/2-IG	10.01.06.02596
SPB4 50 SI-55 G1/4-AG	Schmalz-Connector	SC 090 G1/4-AG	10.01.06.02793
SPB4 50 SI-55 G1/4-IG	Schmalz-Connector	SC 090 G1/4-IG	10.01.06.03273
SPB4 50 SI-55 G3/8-AG	Schmalz-Connector	SC 090 G3/8-AG	10.01.06.02791
SPB4 50 SI-55 G3/8-IG	Schmalz-Connector	SC 090 G3/8-IG	10.01.06.03274
SPB4 50 SI-55 G1/2-AG	Schmalz-Connector	SC 090 G1/2-AG	10.01.06.02595
SPB4 50 SI-55 G1/2-IG	Schmalz-Connector	SC 090 G1/2-IG	10.01.06.02596

\*Additional material specifications at beginning of the section "Vacuum Suction Cups"



## Ordering Data Accessories Bellows Suction Cups SPB4 (4.5 Folds)

Type	Sieve	Hose clamp	Pad Insert PE
SPB4 20	10.07.01.00320	10.07.10.00002	10.01.06.02915
SPB4 30	10.07.01.00320	10.07.10.00002	10.01.06.02855
SPB4 40	10.07.01.00321	10.07.10.00003	10.01.06.02856
SPB4 50	10.07.01.00321	10.07.10.00003	10.01.06.02916



## Technical Data Bellows Suction Cups SPB4 (4.5 Folds)

Type	Suction force at -200 mbar [N]	Suction force at -400 mbar [N]	Suction force [N]*	Pull-off force at -200 mbar [N]	Pull-off force at -400 mbar [N]	Volume [cm <sup>3</sup> ]
SPB4 20	2.6	5.3	8	4.9	7	7.9
SPB4 30	5.3	10.6	16	9.9	13	15.7
SPB4 40	8.3	16.6	25	14.1	23	35.8
SPB4 50	16.5	33.0	50	22.0	37	64.6

\*The specified suction forces are theoretical values at a vacuum of -0.6 bar and with a smooth, dry workpiece surface - they do not include a safety factor

# Bellows Suction Cups SPB4 (4.5 Folds)

Suction area ( $\varnothing$ ) from 20 mm to 50 mm



## Design Data Bellows Suction Cups SPB4 (4.5 Folds)

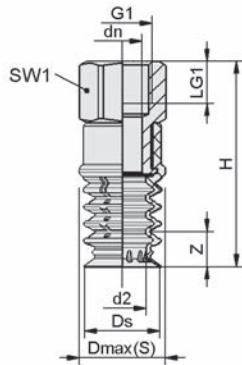

SPB4 20 IG

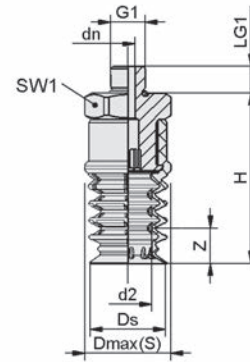

SPB4 20 AG

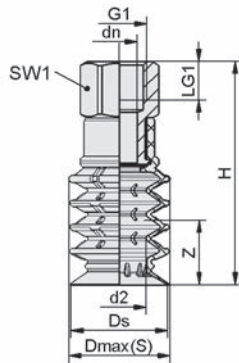

SPB4 30 - 50 IG

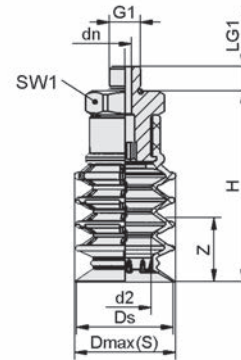

SPB4 30 - 50 AG

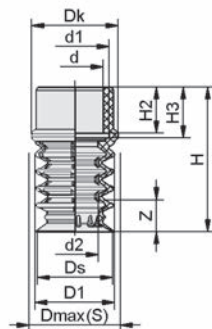

SPB4 20

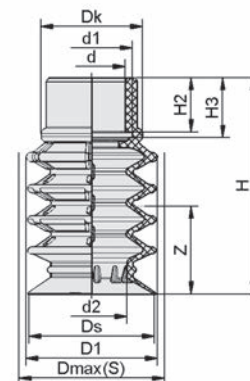

SPB4 30 - 50

- Vacuum Suction Cups
- Special Grippers
- Gripping Systems
- Clamping Systems
- Mounting Elements
- Vacuum Generators
- Valve Technology
- Switches and Monitoring
- Filters and Connections
- Services
- Contact
- Glossary
- Index of Products

# Bellows Suction Cups SPB4 (4.5 Folds)

Suction area (Ø) from 20 mm to 50 mm



## Design Data Bellows Suction Cups SPB4 (4.5 Folds)

Type*	dn [mm]	d2 [mm]	Dmax(S) [mm]**	Ds [mm]	G1	H [mm]	LG1 [mm]	SW1 [mm]	Z (Stroke) [mm]
SPB4 20 SI-55 G1/8-AG	4.0	13.5	24.4	21.4	G1/8"-M	48.4	7.5	22	10
SPB4 20 SI-55 G1/8-IG	8.6	13.5	24.4	21.4	G1/8"-F	58.4	12.0	22	10
SPB4 20 SI-55 G1/4-AG	8.0	13.5	24.4	21.4	G1/4"-M	48.4	10.0	22	10
SPB4 20 SI-55 G1/4-IG	11.0	13.5	24.4	21.4	G1/4"-F	58.4	12.0	22	10
SPB4 20 SI-55 G3/8-AG	10.3	13.5	24.4	21.4	G3/8"-M	48.4	10.0	22	10
SPB4 20 SI-55 G3/8-IG	11.0	13.5	24.4	21.4	G3/8"-F	58.4	12.0	22	10
SPB4 30 SI-55 G1/8-AG	4.0	17.0	31.5	30.2	G1/8"-M	59.5	7.5	22	20
SPB4 30 SI-55 G1/8-IG	8.6	17.0	31.5	30.2	G1/8"-F	69.5	12.0	22	20
SPB4 30 SI-55 G1/4-AG	8.0	17.0	31.5	30.2	G1/4"-M	59.5	10.0	22	20
SPB4 30 SI-55 G1/4-IG	11.0	17.0	31.5	30.2	G1/4"-F	69.5	12.0	22	20
SPB4 30 SI-55 G3/8-AG	10.3	17.0	31.5	30.2	G3/8"-M	59.5	10.0	22	20
SPB4 30 SI-55 G3/8-IG	11.0	17.0	31.5	30.2	G3/8"-F	69.5	12.0	22	20
SPB4 40 SI-55 G1/8-AG	4.0	23.0	41.5	40.5	G1/8"-M	80.6	7.5	27	27
SPB4 40 SI-55 G1/8-IG	8.6	23.0	41.5	40.5	G1/8"-F	87.1	12.0	27	27
SPB4 40 SI-55 G1/4-AG	8.0	23.0	41.5	40.5	G1/4"-M	73.1	10.0	27	27
SPB4 40 SI-55 G1/4-IG	11.4	23.0	41.5	40.5	G1/4"-F	87.1	12.0	27	27
SPB4 40 SI-55 G3/8-AG	10.3	23.0	41.5	40.5	G3/8"-M	73.1	10.0	27	27
SPB4 40 SI-55 G3/8-IG	15.0	23.0	41.5	40.5	G3/8"-F	87.1	12.0	27	27
SPB4 40 SI-55 G1/2-AG	15.0	23.0	41.5	40.5	G1/2"-M	73.1	14.0	27	27
SPB4 40 SI-55 G1/2-IG	15.0	23.0	41.5	40.5	G1/2"-F	87.1	16.0	27	27
SPB4 50 SI-55 G1/8-AG	4.0	30.0	51.5	50.3	G1/8"-M	91.0	7.5	27	37
SPB4 50 SI-55 G1/8-IG	8.6	30.0	51.5	50.3	G1/8"-F	97.5	12.0	27	37
SPB4 50 SI-55 G1/4-AG	8.0	30.0	51.5	50.3	G1/4"-M	83.5	10.0	27	37
SPB4 50 SI-55 G1/4-IG	11.4	30.0	51.5	50.3	G1/4"-F	97.5	12.0	27	37
SPB4 50 SI-55 G3/8-AG	10.3	30.0	51.5	50.3	G3/8"-M	83.5	10.0	27	37
SPB4 50 SI-55 G3/8-IG	15.0	30.0	51.5	50.3	G3/8"-F	97.5	12.0	27	37
SPB4 50 SI-55 G1/2-AG	15.0	30.0	51.5	50.3	G1/2"-M	83.5	14.0	27	37
SPB4 50 SI-55 G1/2-IG	15.0	30.0	51.5	50.3	G1/2"-F	97.5	16.0	27	37

\*Acceptable dimensional tolerances for rubber parts concerning to DIN ISO 3302-1 M3

\*\*External dimension of the suction cup when it is pressed against the workpiece by the vacuum

Type*	d [mm]	d1 [mm]	d2 [mm]	D [mm]**	D1 [mm]	Dk [mm]	Dmax(S) [mm]***	Ds [mm]	H [mm]	H2 [mm]	H3 [mm]	Z (Stroke) [mm]
SPB4 20	16.0	19.6	13.5	30	22.0	24.4	24.4	21.4	41.0	13.0	14.4	10.0
SPB4 30	16.0	19.6	17.0	39	31.0	24.4	31.5	30.2	52.0	13.0	14.4	20.0
SPB4 40	20.0	24.8	23.0	51	41.0	31.0	41.5	40.5	65.6	14.0	16.0	27.0
SPB4 50	20.0	24.8	30.0	61	51.0	31.0	51.5	50.3	76.0	14.0	16.0	36.5

\*Acceptable dimensional tolerances for rubber parts concerning to DIN ISO 3302-1 M3

\*\*These parameters ensure that the suction cup seal on the packaging is correct and that the shear force is maximized when using a support plate

\*\*\*External dimension of the suction cup when it is pressed against the workpiece by the vacuum



# Bellows Suction Cups SPOB1f (Oval, 1.5 Folds)

Suction area (LxW) from 35 x 15 mm to 80 x 35 mm



## Suitability for Industry Specific Applications

### Applications

- Oval bellows suction cup with 1.5 folds for reliable handling of small, film packaging products such as candy bars, popsicles or bulk materials
- Used in packaging lines for processing bulk material packaging in the case-packing process step
- Handling of small flow-wrap packaging with different fill levels
- Stability and high suction force in rapid packaging processes thanks to its oval shape



Bellows Suction Cups SPOB1f (Oval, 1.5 Folds)

### Design

- Oval bellows suction cup with 1.5 folds (3) with a very soft and flexible sealing lip
- Integrated anti-rotation guard and easy-to-use function for positioning the suction cup on the workpiece (2)
- Large shaft diameter for high flow rates
- Mounting using two-piece Schmalz connection element (1) and (4)
- All connection elements SC with male threads come equipped with an integrated sealing ring

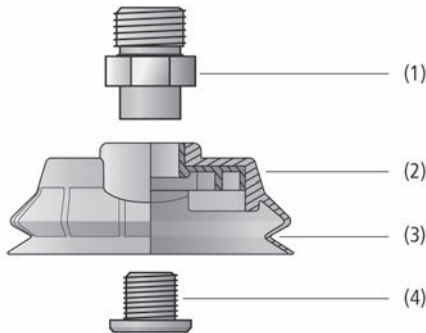

System Design Bellows Suction Cups SPOB1f (Oval, 1.5 Folds)



SPOB1f bellows suction cups for handling small flow-wrap packaging

### Our Highlights...

- FDA compliant Silicone SI material
- Very flexible and easy-to-adapt sealing lip and suction bellows
- Integrated anti-rotation guard
- Large nominal diameter

### Your Benefits...

- Capable of direct use in the food product sector
- Optimum sealing for bag packaging
- Simple and reliable positioning of the suction cup on the workpiece
- High flow rates for short cycle times



# Bellows Suction Cups SPOB1f (Oval, 1.5 Folds)

Suction area (LxW) from 35 x 15 mm to 80 x 35 mm



## Designation Code Bellows Suction Cups SPOB1f (Oval, 1.5 Folds)

<b>SPOB1f</b>	–	<b>60x25</b>	–	<b>SI-55</b>	–	<b>G1/4-AG</b>
1		2		3		4

### 1 – Abbreviated designation

Code	Version
SPOB1f	1.5 folds, oval

### 2 – Suction area

Code	LxW in mm
35x15...80x35	35x15 to 80x35

### 3 – Material

Code	Material
SI-55	Silicone

### 4 – Connection

Code	Connection
G1/8-AG	G1/8-AG (AG = male (M))
G1/8-IG	G1/8-IG (IG = female (F))
G1/4-AG	G1/4-AG
G1/4-IG	G1/4-IG

The SPOB1f suction cup (elastomer part + connection element) with integrated bag stabilizer is delivered assembled. The assembly consists of:

- Suction cup of the type SPOB1f - elastomer part, available in a range of different diameters
- Connection element of the type SC - available with a range of different threads

Available spare parts: suction cup SPOB1f, Schmalz-Connector



## Ordering Data Bellows Suction Cups SPOB1f (Oval, 1.5 Folds)

Type	Part no.
SPOB1f 35x15 SI-55 G1/8-AG	10.01.06.03736
SPOB1f 35x15 SI-55 G1/8-IG	10.01.06.03735
SPOB1f 60x25 SI-55 G1/4-AG	10.01.06.03738
SPOB1f 60x25 SI-55 G1/4-IG	10.01.06.03737
SPOB1f 80x35 SI-55 G1/4-AG	10.01.06.03740
SPOB1f 80x35 SI-55 G1/4-IG	10.01.06.03739



## Ordering Data Spare Parts Bellows Suction Cups SPOB1f (Oval, 1.5 Folds)

Type	Spare Parts	Part no.	
SPOB1f 35x15	Bellows suction cup (oval)	SPOB1f 35x15 SI-55 SC040-AR	10.01.06.03625
SPOB1f 60x25	Bellows suction cup (oval)	SPOB1f 60x25 SI-55 SC050-AR	10.01.06.03626
SPOB1f 80x35	Bellows suction cup (oval)	SPOB1f 80x35 SI-55 SC050-AR	10.01.06.03627

Type	Spare Parts	Part no.	
SPOB1f 35x15 SI-55 G1/8-IG	Schmalz-Connector	SC 040-AR G1/8-IG	10.01.06.02496
SPOB1f 35x15 SI-55 G1/8-AG	Schmalz-Connector	SC 040-AR G1/8-AG	10.01.06.02495
SPOB1f 60x25 SI-55 G1/4-IG	Schmalz-Connector	SC 050-AR G1/4-IG	10.01.06.03742
SPOB1f 60x25 SI-55 G1/4-AG	Schmalz-Connector	SC 050-AR G1/4-AG	10.01.06.03741
SPOB1f 80x35 SI-55 G1/4-IG	Schmalz-Connector	SC 050-AR G1/4-IG	10.01.06.03742
SPOB1f 80x35 SI-55 G1/4-AG	Schmalz-Connector	SC 050-AR G1/4-AG	10.01.06.03741



# Bellows Suction Cups SPOB1f (Oval, 1.5 Folds)

Suction area (LxW) from 35 x 15 mm to 80 x 35 mm

## Technical Data Bellows Suction Cups SPOB1f (Oval, 1.5 Folds)

Type		Suction force at -200 mbar [N]	Suction force at -400 mbar [N]	Suction force [N]*	Min. width of workpiece [mm]	Volume [cm³]	Hose diameter (recom.) d [mm]**
SPOB1f	35x15	4.2	8.4	12.60	10	2.2	6
SPOB1f	60x25	12.2	24.4	36.60	20	11.6	8
SPOB1f	80x35	24.9	49.8	74.70	30	26.2	8

\*The specified suction forces are theoretical values at a vacuum of -0.6 bar and with a smooth, dry workpiece surface - they do not include a safety factor

\*\*The recommended hose diameter refers to a hose length of approx. 2 m

## Design Data Bellows Suction Cups SPOB1f (Oval, 1.5 Folds)

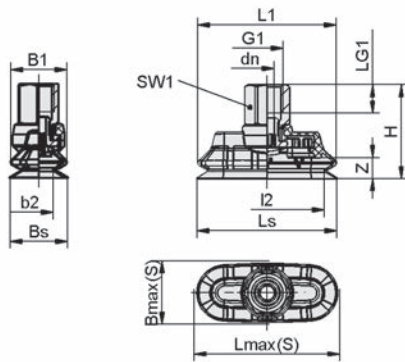

SPOB1f IG

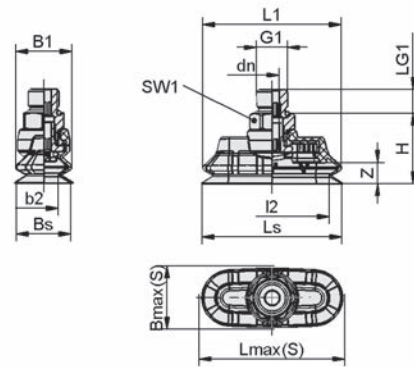

SPOB1f AG

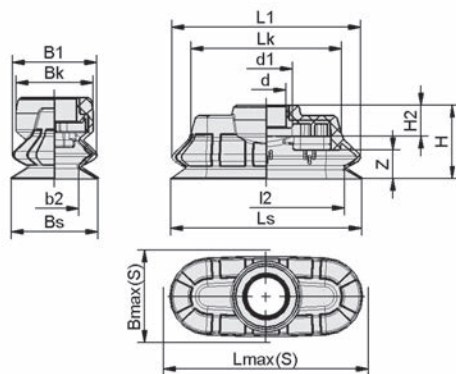

SPOB1f

# Bellows Suction Cups SPOB1f (Oval, 1.5 Folds)

Suction area (LxW) from 35 x 15 mm to 80 x 35 mm



## Design Data Bellows Suction Cups SPOB1f (Oval, 1.5 Folds)

Type*	B1 [mm]	b2 [mm]	Bmax(S) [mm]**	Bs [mm]	dn [mm]	G1	H [mm]	L1 [mm]	I2 [mm]	LG1 [mm]	Ls [mm]	Lmax(S) [mm]***	SW1 [mm]	Z (Stroke) [mm]
SPOB1f 35x15 SI-55 G1/8-AG	15	8	17	15	4.1	G1/8"-M	19.0	35	28	8	35	37	14	4
SPOB1f 35x15 SI-55 G1/8-IG	15	8	17	15	4.1	G1/8"-F	27.0	35	28	8	35	37	14	4
SPOB1f 60x25 SI-55 G1/4-AG	25	14	27	25	6.1	G1/4"-M	30.2	60	49	10	60	62	17	9
SPOB1f 60x25 SI-55 G1/4-IG	25	14	27	25	6.1	G1/4"-F	40.2	60	49	12	60	62	17	9
SPOB1f 80x35 SI-55 G1/4-AG	35	21	38	35	6.1	G1/4"-M	34.2	80	66	10	80	83	17	11
SPOB1f 80x35 SI-55 G1/4-IG	35	21	38	35	6.1	G1/4"-F	44.2	80	66	12	80	83	17	11

\*Acceptable dimensional tolerances for rubber parts concerning to DIN ISO 3302-1 M3

\*\*External dimension of the suction cup when it is pressed against the workpiece by the vacuum

\*\*\*External dimension of the suction cup when it is pressed against the workpiece by the vacuum

Type*	b2 [mm]	B1 [mm]	Bk [mm]	Bmax(S) [mm]**	Bs [mm]	d [mm]	d1 [mm]	H [mm]	H2 [mm]	I2 [mm]	L1 [mm]	Lk [mm]	Ls [mm]	Lmax(S) [mm]***	Z (Stroke) [mm]
SPOB1f 35x15 SI-55 SC040-AR	8.0	15	14	17	14.6	8.3	11.0	13	5.0	28.0	35	28.5	34.6	37	4
SPOB1f 60x25 SI-55 SC050-AR	13.8	25	22	27	24.5	12.4	17.3	23	6.9	48.8	60	46.9	59.5	62	9
SPOB1f 80x35 SI-55 SC050-AR	21.0	35	24	38	34.5	12.4	17.3	27	6.9	66.0	80	61.1	79.5	83	11

\*Acceptable dimensional tolerances for rubber parts concerning to DIN ISO 3302-1 M3

\*\*External dimension of the suction cup when it is pressed against the workpiece by the vacuum

\*\*\*External dimension of the suction cup when it is pressed against the workpiece by the vacuum

# Bellows Suction Cups SPB2f (2.5 Folds)

Suction area (Ø) from 30 mm to 50 mm



## Suitability for Industry Specific Applications



Bellows Suction Cups SPB2f (2.5 Folds)

## Applications

- Round bellows suction cup with 2.5 folds for dynamical handling of pouches and other types of very flexible packaging
- Reliably gripping and handling of pouches containing fluids, solids or powder and packaging that is not very full
- Stable in extremely quick packaging processes, particularly in conjunction with delta robots (case packer and pick-and-place applications)

Schmalz – The Company  
Vacuum Suction Cups

Special Grippers

Gripping Systems

Clamping Systems

Mounting Elements

Vacuum Generators

Valve Technology

Switches and Monitoring

Filters and Connections

Services

Contact

Glossary

Index of Products

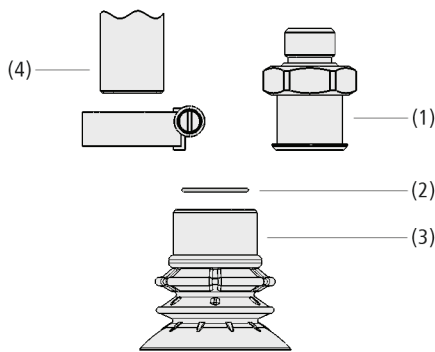

System Design Bellows Suction Cups SPB2f (2.5 Folds)

## Design

- SPB2f bellows suction cup with 2.5 folds (3) and a gentle and flexible sealing lip with segmented flow vanes and integrated bag stabilizer
- Very large shaft diameter for high volume flow rates
- Specially reinforced suction bellows for additional stability
- Installation using the Schmalz connection element SC (1); alternatively direct attachment on pipe (4) via hose clamp
- All SC connection elements with male thread are equipped with an integrated sealing ring
- Optional insert filter for pre-filter (2)



Bellows suction cup SPB2f for handling pouches

## Our Highlights...

- FDA compliant Silicone SI material
- Integrated bag stabilizer
- Compact, reinforced main body with 2.5 folds
- Large nominal diameter

## Your Benefits...

- Can be used directly in the food industry
- Pouch stabilization; even thin and soft plastic films are not sucked in
- Secure grip and stability, even at high speeds
- High flow rate for short cycle times



# Bellows Suction Cups SPB2f (2.5 Folds)

Suction area (Ø) from 30 mm to 50 mm



## Designation Code Bellows Suction Cups SPB2f (2.5 Folds)

<b>SPB2f</b>	–	<b>30</b>	–	<b>SI-55</b>	–	<b>G1/8-AG</b>
<b>1</b>		<b>2</b>		<b>3</b>		<b>4</b>

### 1 – Abbreviated designation

Code	Version
SPB2f	2.5 folds

### 2 – Suction area

Code	Diameter in mm
30...50	ø 30 to 50

### 3 – Material

Code	Material
SI-55	Silicone

### 4 – Connection

Code	Connection
G1/8-AG	G1/8-AG (AG = male (M))
G1/8-IG	G1/8-IG (IG = female (F))
G1/4-AG	G1/4-AG
G1/4-IG	G1/4-IG
G3/8-AG	G3/8-AG
G3/8-IG	G3/8-IG
G1/2-AG	G1/2-AG
G1/2-IG	G1/2-IG

Suction cup SPB2f (elastomer part + connection element) is delivered assembled. The assembly consists of:

- Suction cup of type SPB2f - elastomer part, available in various diameters
- Connection element of type SC - available with various threads

Available spare parts: suction cup SPB2f, Schmalz-Connector



## Ordering Data Bellows Suction Cups SPB2f (2.5 Folds)

Type	Part no.
SPB2f 30 SI-55 G1/8-AG	10.01.06.03698
SPB2f 30 SI-55 G1/8-IG	10.01.06.03699
SPB2f 30 SI-55 G1/4-AG	10.01.06.03700
SPB2f 30 SI-55 G1/4-IG	10.01.06.03701
SPB2f 30 SI-55 G3/8-AG	10.01.06.03702
SPB2f 30 SI-55 G3/8-IG	10.01.06.03703
SPB2f 40 SI-55 G1/8-AG	10.01.06.03646
SPB2f 40 SI-55 G1/8-IG	10.01.06.03647
SPB2f 40 SI-55 G1/4-AG	10.01.06.03648
SPB2f 40 SI-55 G1/4-IG	10.01.06.03649
SPB2f 40 SI-55 G3/8-AG	10.01.06.03650
SPB2f 40 SI-55 G3/8-IG	10.01.06.03651
SPB2f 50 SI-55 G1/8-AG	10.01.06.03652
SPB2f 50 SI-55 G1/8-IG	10.01.06.03653
SPB2f 50 SI-55 G1/4-AG	10.01.06.03654
SPB2f 50 SI-55 G1/4-IG	10.01.06.03655
SPB2f 50 SI-55 G3/8-AG	10.01.06.03656
SPB2f 50 SI-55 G3/8-IG	10.01.06.03657
SPB2f 50 SI-55 G1/2-AG	10.01.06.03658
SPB2f 50 SI-55 G1/2-IG	10.01.06.03659



## Ordering Data Spare Parts Bellows Suction Cups SPB2f (2.5 Folds)

Type	Spare Parts	Part no.
SPB2f 30	Bellows suction cup (round)	SPB2f 30 SI-55 SC080 10.01.06.03643
SPB2f 40	Bellows suction cup (round)	SPB2f 40 SI-55 SC080 10.01.06.03559
SPB2f 50	Bellows suction cup (round)	SPB2f 50 SI-55 SC090 10.01.06.03560



# Bellows Suction Cups SPB2f (2.5 Folds)

Suction area (Ø) from 30 mm to 50 mm



## Ordering Data Spare Parts Bellows Suction Cups SPB2f (2.5 Folds)

Type	Spare Parts		Part no.
SPB2f 30 SI-55 G1/8-AG	Schmalz-Connector	SC 080 G1/8-AG	10.01.06.03142
SPB2f 30 SI-55 G1/8-IG	Schmalz-Connector	SC 080 G1/8-IG	10.01.06.03270
SPB2f 30 SI-55 G1/4-AG	Schmalz-Connector	SC 080 G1/4-AG	10.01.06.03268
SPB2f 30 SI-55 G1/4-IG	Schmalz-Connector	SC 080 G1/4-IG	10.01.06.03271
SPB2f 30 SI-55 G3/8-AG	Schmalz-Connector	SC 080 G3/8-AG	10.01.06.02593
SPB2f 30 SI-55 G3/8-IG	Schmalz-Connector	SC 080 G3/8-IG	10.01.06.02594
SPB2f 40 SI-55 G1/8-AG	Schmalz-Connector	SC 080 G1/8-AG	10.01.06.03142
SPB2f 40 SI-55 G1/8-IG	Schmalz-Connector	SC 080 G1/8-IG	10.01.06.03270
SPB2f 40 SI-55 G1/4-AG	Schmalz-Connector	SC 080 G1/4-AG	10.01.06.03268
SPB2f 40 SI-55 G1/4-IG	Schmalz-Connector	SC 080 G1/4-IG	10.01.06.03271
SPB2f 40 SI-55 G3/8-AG	Schmalz-Connector	SC 080 G3/8-AG	10.01.06.02593
SPB2f 40 SI-55 G3/8-IG	Schmalz-Connector	SC 080 G3/8-IG	10.01.06.02594
SPB2f 50 SI-55 G1/8-AG	Schmalz-Connector	SC 090 G1/8-AG	10.01.06.03269
SPB2f 50 SI-55 G1/8-IG	Schmalz-Connector	SC 090 G1/8-IG	10.01.06.03272
SPB2f 50 SI-55 G1/4-AG	Schmalz-Connector	SC 090 G1/4-AG	10.01.06.02793
SPB2f 50 SI-55 G1/4-IG	Schmalz-Connector	SC 090 G1/4-IG	10.01.06.03273
SPB2f 50 SI-55 G3/8-AG	Schmalz-Connector	SC 090 G3/8-AG	10.01.06.02791
SPB2f 50 SI-55 G3/8-IG	Schmalz-Connector	SC 090 G3/8-IG	10.01.06.03274
SPB2f 50 SI-55 G1/2-AG	Schmalz-Connector	SC 090 G1/2-AG	10.01.06.02595
SPB2f 50 SI-55 G1/2-IG	Schmalz-Connector	SC 090 G1/2-IG	10.01.06.02596



## Technical Data Bellows Suction Cups SPB2f (2.5 Folds)

Type	Suction force at -200 mbar	Suction force at -400 mbar	Suction force	Volume
	[N]	[N]	[N]*	[cm <sup>3</sup> ]
SPB2f 30	4.3	8.5	12.8	7.2
SPB2f 40	6.8	13.6	20.4	12.9
SPB2f 50	13.7	27.3	41.0	26.5

\*The specified suction forces are theoretical values at a vacuum of -0.6 bar and with a smooth, dry workpiece surface - they do not include a safety factor



## Design Data Bellows Suction Cups SPB2f (2.5 Folds)

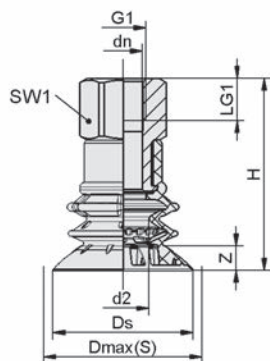

SPB2f IG

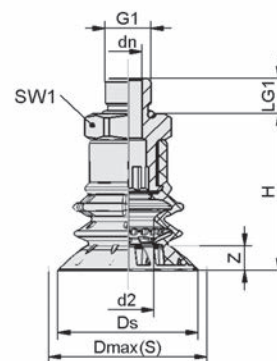

SPB2f AG



Schmalz – The Company  
Vacuum Suction Cups  
Special Grippers  
Gripping Systems  
Clamping Systems  
Mounting Elements  
Vacuum Generators  
Valve Technology  
Switches and Monitoring  
Filters and Connections  
Services  
Contact  
Glossary  
Index of Products

# Bellows Suction Cups SPB2f (2.5 Folds)

Suction area (Ø) from 30 mm to 50 mm

## Design Data Bellows Suction Cups SPB2f (2.5 Folds)

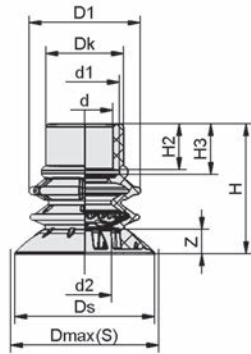

SPB2f

Type*	d2 [mm]	Dmax(S) [mm]**	dn [mm]	Ds [mm]	G1	H [mm]	LG1 [mm]	SW1 [mm]	Z (Stroke) [mm]
SPB2f 30 SI-55 G1/8-AG	7.2	32.0	4.0	30.0	G1/8"-M	40	7.5	22	5
SPB2f 30 SI-55 G1/8-IG	7.2	32.0	8.6	30.0	G1/8"-F	50	12.0	22	5
SPB2f 30 SI-55 G1/4-AG	7.2	32.0	8.0	30.0	G1/4"-M	40	10.0	22	5
SPB2f 30 SI-55 G1/4-IG	7.2	32.0	11.0	30.0	G1/4"-F	50	12.0	22	5
SPB2f 30 SI-55 G3/8-AG	7.2	32.0	10.3	30.0	G3/8"-M	40	10.0	22	5
SPB2f 30 SI-55 G3/8-IG	7.2	32.0	11.0	30.0	G3/8"-F	50	12.0	22	5
SPB2f 40 SI-55 G1/8-AG	15.3	42.0	4.0	39.7	G1/8"-M	45	7.5	22	7
SPB2f 40 SI-55 G1/8-IG	15.3	42.0	8.6	39.7	G1/8"-F	55	12.0	22	7
SPB2f 40 SI-55 G1/4-AG	15.3	42.0	8.0	39.7	G1/4"-M	45	10.0	22	7
SPB2f 40 SI-55 G1/4-IG	15.3	42.0	11.0	39.7	G1/4"-F	55	12.0	22	7
SPB2f 40 SI-55 G3/8-AG	15.3	42.0	10.3	39.7	G3/8"-M	45	10.0	22	7
SPB2f 40 SI-55 G3/8-IG	15.3	42.0	11.0	39.7	G3/8"-F	55	12.0	22	7
SPB2f 50 SI-55 G1/8-AG	21.0	52.0	4.0	49.7	G1/8"-M	54	7.5	27	9
SPB2f 50 SI-55 G1/8-IG	21.0	52.0	8.6	49.7	G1/8"-F	68	12.0	27	9
SPB2f 50 SI-55 G1/4-AG	21.0	52.0	8.0	49.7	G1/4"-M	54	10.0	27	9
SPB2f 50 SI-55 G1/4-IG	21.0	52.0	11.4	49.7	G1/4"-F	68	12.0	27	9
SPB2f 50 SI-55 G3/8-AG	21.0	52.0	10.3	49.7	G3/8"-M	54	10.0	27	9
SPB2f 50 SI-55 G3/8-IG	21.0	52.0	15.0	49.7	G3/8"-F	68	12.0	27	9
SPB2f 50 SI-55 G1/2-AG	21.0	52.0	15.0	49.7	G1/2"-M	54	14.0	27	9
SPB2f 50 SI-55 G1/2-IG	21.0	52.0	15.0	49.7	G1/2"-F	68	16.0	27	9

\*Acceptable dimensional tolerances for rubber parts concerning to DIN ISO 3302-1 M3

\*\*External dimension of the suction cup when it is pressed against the workpiece by the vacuum

Type*	d	d1	d2	D1	Dk	Dmax(S)	Ds	H	H2	H3	Z (Stroke)
	[mm]	[mm]	[mm]	[mm]	[mm]	[mm]**	[mm]	[mm]	[mm]	[mm]	[mm]
SPB2f 30	16.0	19.6	7.2	24.4	22.0	32.0	30.0	32.3	13.0	14.4	5
SPB2f 40	16.0	19.6	15.3	31.6	24.4	42.0	39.7	37.0	13.0	14.4	7
SPB2f 50	20.0	24.8	21.0	41.6	31.0	52.0	49.7	45.6	14.0	16.0	9

\*Acceptable dimensional tolerances for rubber parts concerning to DIN ISO 3302-1 M3

\*\*External dimension of the suction cup when it is pressed against the workpiece by the vacuum

Schmalz - The Company  
 Vacuum Suction Cups  
 Special Grippers  
 Gripping Systems  
 Clamping Systems  
 Mounting Elements  
 Vacuum Generators  
 Valve Technology  
 Switches and Monitoring  
 Filters and Connections  
 Services  
 Contact  
 Glossary  
 Index of Products



# Bellows Suction Cups SPB4f (4.5 Folds)

Suction area (Ø) from 30 mm to 50 mm



## Suitability for Industry Specific Applications



Bellows Suction Cups SPB4f (4.5 Folds)

### Applications

- Round, bellows suction cup with 4.5 folds for handling pouches and other very flexible packaging
- Reliable gripping and handling especially of pouches and packaging with low filling degree as well as liquid, solid or powder filled pouches
- For use in fast packaging processes, particularly together with delta robots (case packers and pick-and-place applications)

Schmalz – The Company  
Vacuum Suction Cups

Special Grippers

Gripping Systems

Clamping Systems

Mounting Elements

Vacuum Generators

Valve Technology

Switches and Monitoring

Filters and Connections

Services

Contact

Glossary

Index of Products

### Design

- Bellows suction cup SPB4f with 4.5 folds (1) as well as soft, flexible sealing lip with segmented flow fins and integrated bag stabilizer
- Very large shaft diameter for high volume flow rates
- Special reinforced bellows for additional stability
- Installation using the Schmalz connection element SC (3); alternatively by attaching directly onto a pipe (4) on the machine side and fixing with a hose clamp
- All connection elements SC with male thread are equipped with an integrated sealing ring
- Optional filter as pre-filter (2)

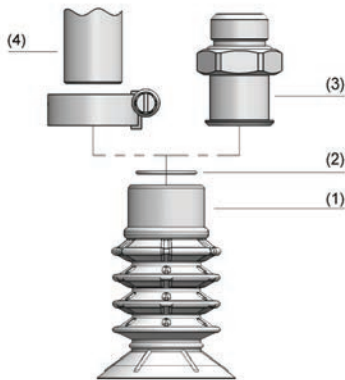

System Design Bellows Suction Cups SPB4f (4.5 Folds)



Bellows suction cup SPB4f for handling pouches

### Our Highlights...

- Suction cup made from FDA compliant silicone SI
- Integrated pouch stabilizer
- Reinforced basic body and folds
- Very large nominal diameter
- Extremely flexible and adaptable sealing lip

### Your Benefits...

- Can be used directly in the food industry
- Pouch stabilization; thin and soft plastic films are not drawn in
- Secure gripping with high lateral loads
- High volume flow rates and short cycle times
- Optimal sealing on pouches with strong wrinkles



# Bellows Suction Cups SPB4f (4.5 Folds)

Suction area (Ø) from 30 mm to 50 mm



## Designation Code Bellows Suction Cups SPB4f (4.5 Folds)

<b>SPB4f</b>	-	<b>40</b>	-	<b>SI-55</b>	-	<b>G1/8-IG</b>
<b>1</b>		<b>2</b>		<b>3</b>		<b>4</b>

### 1 – Abbreviated designation

Code	Version
SPB4f	4.5 folds

### 2 – Suction area

Code	Diameter in mm
30...50	ø 30 to 50

### 3 – Material

Code	Material
SI-55	Silicone

### 4 – Connection

Code	Connection
G1/8-AG	G1/8-AG (AG = male (M))
G1/8-IG	G1/8-IG (IG = female (F))
G1/4-AG	G1/4-AG
G1/4-IG	G1/4-IG
G3/8-AG	G3/8-AG
G3/8-IG	G3/8-IG
G1/2-AG	G1/2-AG
G1/2-IG	G1/2-IG

Suction cup SPB4f (elastomer part + connection element) with integrated bag stabilizer is delivered assembled.

The assembly consists of:

- Suction cup of type SPB4f – elastomer part, available in various diameters
- Connection element of type SC – available with various threads

Available spare parts: suction cup SPB4f, Schmalz-Connector

Available accessories: filter screen (sieve, round), hose clamp



## Ordering Data Bellows Suction Cups SPB4f (4.5 Folds)

Type	Part no.
SPB4f 30 SI-55 G1/8-AG	10.01.06.03538
SPB4f 30 SI-55 G1/8-IG	10.01.06.03541
SPB4f 30 SI-55 G1/4-AG	10.01.06.03539
SPB4f 30 SI-55 G1/4-IG	10.01.06.03542
SPB4f 30 SI-55 G3/8-AG	10.01.06.03540
SPB4f 30 SI-55 G3/8-IG	10.01.06.03543
SPB4f 40 SI-55 G1/8-AG	10.01.06.03544
SPB4f 40 SI-55 G1/8-IG	10.01.06.03547
SPB4f 40 SI-55 G1/4-AG	10.01.06.03545
SPB4f 40 SI-55 G1/4-IG	10.01.06.03548
SPB4f 40 SI-55 G3/8-AG	10.01.06.03546
SPB4f 40 SI-55 G3/8-IG	10.01.06.03549
SPB4f 50 SI-55 G1/8-AG	10.01.06.03550
SPB4f 50 SI-55 G1/8-IG	10.01.06.03554
SPB4f 50 SI-55 G1/4-AG	10.01.06.03551
SPB4f 50 SI-55 G1/4-IG	10.01.06.03555
SPB4f 50 SI-55 G3/8-AG	10.01.06.03552
SPB4f 50 SI-55 G3/8-IG	10.01.06.03556
SPB4f 50 SI-55 G1/2-AG	10.01.06.03553
SPB4f 50 SI-55 G1/2-IG	10.01.06.03557



# Bellows Suction Cups SPB4f (4.5 Folds)

Suction area ( $\varnothing$ ) from 30 mm to 50 mm

## Ordering Data Spare Parts Bellows Suction Cups SPB4f (4.5 Folds)

Type	Spare Parts		Part no.
SPB4f 30	Bellows suction cup (round)	SPB4f 30 SI-55 SC080	10.01.06.03264
SPB4f 40	Bellows suction cup (round)	SPB4f 40 SI-55 SC080	10.01.06.03265
SPB4f 50	Bellows suction cup (round)	SPB4f 50 SI-55 SC090	10.01.06.03266

Type	Spare Parts		Part no.
SPB4f 30 SI-55 G1/8-AG	Schmalz-Connector	SC 080 G1/8-AG	10.01.06.03142
SPB4f 30 SI-55 G1/8-IG	Schmalz-Connector	SC 080 G1/8-IG	10.01.06.03270
SPB4f 30 SI-55 G1/4-AG	Schmalz-Connector	SC 080 G1/4-AG	10.01.06.03268
SPB4f 30 SI-55 G1/4-IG	Schmalz-Connector	SC 080 G1/4-IG	10.01.06.03271
SPB4f 30 SI-55 G3/8-AG	Schmalz-Connector	SC 080 G3/8-AG	10.01.06.02593
SPB4f 30 SI-55 G3/8-IG	Schmalz-Connector	SC 080 G3/8-IG	10.01.06.02594
SPB4f 40 SI-55 G1/8-AG	Schmalz-Connector	SC 080 G1/8-AG	10.01.06.03142
SPB4f 40 SI-55 G1/8-IG	Schmalz-Connector	SC 080 G1/8-IG	10.01.06.03270
SPB4f 40 SI-55 G1/4-AG	Schmalz-Connector	SC 080 G1/4-AG	10.01.06.03268
SPB4f 40 SI-55 G1/4-IG	Schmalz-Connector	SC 080 G1/4-IG	10.01.06.03271
SPB4f 40 SI-55 G3/8-AG	Schmalz-Connector	SC 080 G3/8-AG	10.01.06.02593
SPB4f 40 SI-55 G3/8-IG	Schmalz-Connector	SC 080 G3/8-IG	10.01.06.02594
SPB4f 50 SI-55 G1/8-AG	Schmalz-Connector	SC 090 G1/8-AG	10.01.06.03269
SPB4f 50 SI-55 G1/8-IG	Schmalz-Connector	SC 090 G1/8-IG	10.01.06.03272
SPB4f 50 SI-55 G1/4-AG	Schmalz-Connector	SC 090 G1/4-AG	10.01.06.02793
SPB4f 50 SI-55 G1/4-IG	Schmalz-Connector	SC 090 G1/4-IG	10.01.06.03273
SPB4f 50 SI-55 G3/8-AG	Schmalz-Connector	SC 090 G3/8-AG	10.01.06.02791
SPB4f 50 SI-55 G3/8-IG	Schmalz-Connector	SC 090 G3/8-IG	10.01.06.03274
SPB4f 50 SI-55 G1/2-AG	Schmalz-Connector	SC 090 G1/2-AG	10.01.06.02595
SPB4f 50 SI-55 G1/2-IG	Schmalz-Connector	SC 090 G1/2-IG	10.01.06.02596



## Ordering Data Accessories Bellows Suction Cups SPB4f (4.5 Folds)

Type	Accessories		Part no.
SPB4f 30	Sieve, round	SIEB 17x0.8 MS-A2 103 0.103/0.07	10.07.01.00320
SPB4f 40	Sieve, round	SIEB 17x0.8 MS-A2 103 0.103/0.07	10.07.01.00320
SPB4f 50	Sieve, round	SIEB 19.5x1 MS-A2 103	10.07.01.00321

Type	Accessories		Part no.
SPB4f 30	Hose clamp	SSB 16-27 ST-VZ	10.07.10.00002
SPB4f 40	Hose clamp	SSB 16-27 ST-VZ	10.07.10.00002
SPB4f 50	Hose clamp	SSB 20-32 ST-VZ	10.07.10.00003



## Technical Data Bellows Suction Cups SPB4f (4.5 Folds)

Type	Suction force at -200 mbar [N]	Suction force at -400 mbar [N]	Suction force [N]*	Volume [cm <sup>3</sup> ]
SPB4f 30	4.3	8.5	12.80	6.0
SPB4f 40	6.8	13.6	20.40	15.2
SPB4f 50	13.7	27.3	41.00	33.2

\*The specified suction forces are theoretical values at a vacuum of -0.6 bar and with a smooth, dry workpiece surface - they do not include a safety factor



# Bellows Suction Cups SPB4f (4.5 Folds)

Suction area ( $\emptyset$ ) from 30 mm to 50 mm

**Design Data Bellows Suction Cups SPB4f (4.5 Folds)**

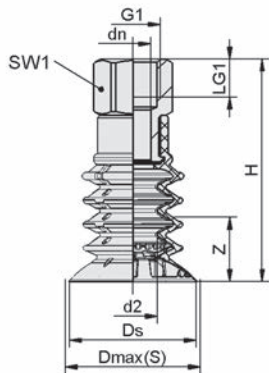

SPB4f IG

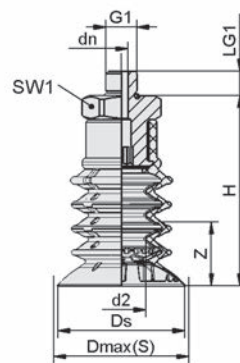

SPB4f AG

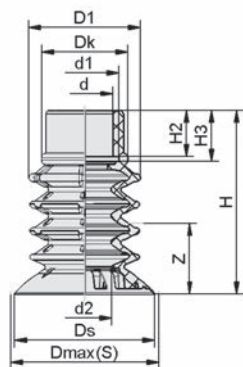

SPB4f

Type*	dn [mm]	d2 [mm]	Dmax(S) [mm]**	Ds [mm]	G1	H [mm]	LG1 [mm]	SW1 [mm]	Z (Stroke) [mm]
SPB4f 30 SI-55 G1/8-AG	4.0	12.3	32.0	30.7	G1/8"-M	47.5	7.5	22	10
SPB4f 30 SI-55 G1/8-IG	8.6	12.3	32.0	30.7	G1/8"-F	57.5	12.0	22	10
SPB4f 30 SI-55 G1/4-AG	8.0	12.3	32.0	30.7	G1/4"-M	47.5	10.0	22	10
SPB4f 30 SI-55 G1/4-IG	11.0	12.3	32.0	30.7	G1/4"-F	57.5	12.0	22	10
SPB4f 30 SI-55 G3/8-AG	10.3	12.3	32.0	30.7	G3/8"-M	47.5	10.0	22	10
SPB4f 30 SI-55 G3/8-IG	11.0	12.3	32.0	30.7	G3/8"-F	57.5	12.0	22	10
SPB4f 40 SI-55 G1/8-AG	4.0	15.3	42.0	39.7	G1/8"-M	59.5	7.5	22	20
SPB4f 40 SI-55 G1/8-IG	8.6	15.3	42.0	39.7	G1/8"-F	69.5	12.0	22	20
SPB4f 40 SI-55 G1/4-AG	8.0	15.3	42.0	39.7	G1/4"-M	59.5	10.0	22	20
SPB4f 40 SI-55 G1/4-IG	11.0	15.3	42.0	39.7	G1/4"-F	69.5	12.0	22	20
SPB4f 40 SI-55 G3/8-AG	10.3	15.3	42.0	39.7	G3/8"-M	59.5	10.0	22	20
SPB4f 40 SI-55 G3/8-IG	11.0	15.3	42.0	39.7	G3/8"-F	69.5	12.0	22	20
SPB4f 50 SI-55 G1/8-AG	4.0	21.0	52.0	49.7	G1/8"-M	72.5	7.5	27	26
SPB4f 50 SI-55 G1/8-IG	8.6	21.0	52.0	49.7	G1/8"-F	86.5	12.0	27	26

Schmalz - The Company  
Vacuum Suction Cups  
Special Grippers  
Gripping Systems  
Clamping Systems  
Mounting Elements  
Vacuum Generators  
Valve Technology  
Switches and Monitoring  
Filters and Connections  
Services  
Contact  
Glossary  
Index of Products

# Bellows Suction Cups SPB4f (4.5 Folds)

Suction area ( $\emptyset$ ) from 30 mm to 50 mm

## Design Data Bellows Suction Cups SPB4f (4.5 Folds)

Type*	dn [mm]	d2 [mm]	Dmax(S) [mm]**	Ds [mm]	G1	H [mm]	LG1 [mm]	SW1 [mm]	Z (Stroke) [mm]
SPB4f 50 SI-55 G1/4-AG	8.0	21.0	52.0	49.7	G1/4"-M	72.5	10.0	27	26
SPB4f 50 SI-55 G1/4-IG	11.4	21.0	52.0	49.7	G1/4"-F	86.5	12.0	27	26
SPB4f 50 SI-55 G3/8-AG	10.3	21.0	52.0	49.7	G3/8"-M	72.5	10.0	27	26
SPB4f 50 SI-55 G3/8-IG	15.0	21.0	52.0	49.7	G3/8"-F	86.5	12.0	27	26
SPB4f 50 SI-55 G1/2-AG	15.0	21.0	52.0	49.7	G1/2"-M	72.5	14.0	27	26
SPB4f 50 SI-55 G1/2-IG	15.0	21.0	52.0	49.7	G1/2"-F	86.5	16.0	27	26

\*Acceptable dimensional tolerances for rubber parts concerning to DIN ISO 3302-1 M3

\*\*External dimension of the suction cup when it is pressed against the workpiece by the vacuum

Type*	d [mm]	d1 [mm]	d2 [mm]	D1 [mm]	Dk [mm]	Dmax(S) [mm]**	Ds [mm]	H [mm]	H2 [mm]	H3 [mm]	Z (Stroke) [mm]
SPB4f 30	16.0	19.6	12.3	22.4	24.4	32	30.7	40.0	13.0	14.4	10
SPB4f 40	16.0	19.6	15.3	31.6	24.4	42	39.7	52.0	13.0	14.4	20
SPB4f 50	20.0	24.8	21.0	41.6	31.0	52	49.7	65.0	14.0	16.0	26

\*Acceptable dimensional tolerances for rubber parts concerning to DIN ISO 3302-1 M3

\*\*External dimension of the suction cup when it is pressed against the workpiece by the vacuum

# Bellows Suction Cups FGA PVC (1.5 Folds)

Suction area (Ø) from 13 mm to 22 mm



## Suitability for Industry Specific Applications

### Applications

- Round, bellows suction cup with 1.5 folds for handling of fragile workpieces thanks to damping effect of corrugations and soft sealing lip
- Usage in box openers and for handling of non-rigid workpieces and soft packaging materials
- Handling tasks in special processes which use chlorinated water, such as rinsing of plastic bags



Bellows Suction Cups FGA PVC (1.5 Folds)

### Design

- Robust and wear-resistant suction cup FGA (2) with 1.5 folds and single sealing lip
- Very adaptable geometry and soft, flexible material
- Large effective internal diameter
- With each nipple family, the replacement cups and nipples (1) can be combined as desired (3)

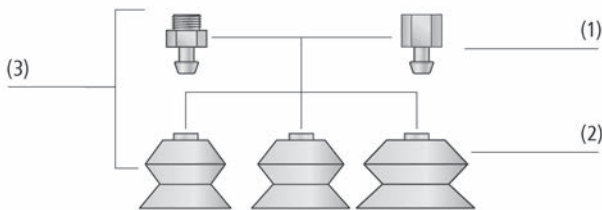

System Design Bellows Suction Cups FGA PVC (1.5 Folds)



Bellows suction cups FGA PVC being used for handling non-rigid workpieces

### Our Highlights...

- 1.5 folds
- Large effective internal diameter
- Soft and adaptable sealing lip and bottom corrugation
- Stiffer upper corrugation

### Your Benefits...

- Good damping when positioning on workpiece
- High suction force
- Good adaptation to curved or uneven surfaces
- High stability against horizontal acceleration

Schmalz – The Company  
 Vacuum Suction Cups  
 Special Grippers  
 Gripping Systems  
 Clamping Systems  
 Mounting Elements  
 Vacuum Generators  
 Valve Technology  
 Switches and Monitoring  
 Filters and Connections  
 Services  
 Contact  
 Glossary  
 Index of Products



# Bellows Suction Cups FGA PVC (1.5 Folds)

Suction area (Ø) from 13 mm to 22 mm



## Designation Code Bellows Suction Cups FGA PVC (1.5 Folds)

FGA	-	13	-	PVC-50	-	N016
1		2		3		4

### 1 – Abbreviated designation

Code	Version
FGA	1.5 folds

### 2 – Suction area

Code	Diameter in mm
13...22	ø 13 to 22

### 3 – Material

Code	Material
PVC-50	Polyvinylchloride

### 4 – Connection

Code	Connection
N016	N016
N056	N056

Suction cup FGA PVC (elastomer part) is supplied as an individual part.

In order to receive a complete suction cup (elastomer part + connection nipple), the following ordering steps are required:

- Suction cup of type FGA PVC – elastomer part, available in various diameters
- Connection nipple of type SA-NIP – available with various threads



## Ordering Data Bellows Suction Cups FGA PVC (1.5 Folds)

Type*	Part no.
FGA 13 PVC-50 N016	10.01.06.01549
FGA 19 PVC-50 N056	10.01.06.01975
FGA 22 PVC-50 N016	10.01.06.01947

\*Additional material specifications at beginning of the section "Vacuum Suction Cups"



## Ordering Data Accessories Bellows Suction Cups FGA PVC (1.5 Folds)

Type	Accessories	M5-AG	G1/8-AG	G1/8-IG
FGA 13	Suction cup connection nipple	10.01.06.00123	10.01.06.05735	10.01.06.05731
FGA 19	Suction cup connection nipple	10.01.06.03080	10.01.06.03571	10.01.06.03572
FGA 22	Suction cup connection nipple	10.01.06.00123	10.01.06.05735	10.01.06.05731



## Technical Data Bellows Suction Cups FGA PVC (1.5 Folds)

Type	Suction force [N]*	Pull-off force [N]	Volume [cm <sup>3</sup> ]	Workpiece radius min. (convex) [mm]	Hose diameter (recom.) d [mm]**
FGA 13 PVC-50 N016	1.7	6	0.7	10	4
FGA 19 PVC-50 N056	5.9	10	2.1	20	4
FGA 22 PVC-50 N016	5.3	16	2.3	20	4

\*The specified suction forces are theoretical values at a vacuum of -0.6 bar and with a smooth, dry workpiece surface - they do not include a safety factor

\*\*The recommended hose diameter refers to a hose length of approx. 2 m

# Bellows Suction Cups FGA PVC (1.5 Folds)

Suction area ( $\emptyset$ ) from 13 mm to 22 mm



## Design Data Bellows Suction Cups FGA PVC (1.5 Folds)

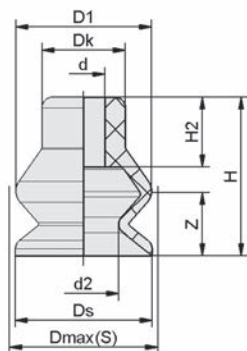

FGA 13 PVC-50

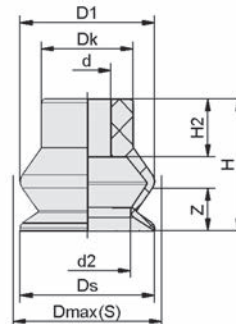

FGA 19 PVC-50

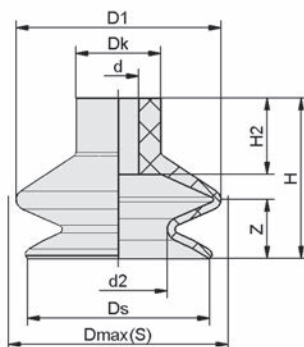

FGA 22 PVC-50

Type*	D1 [mm]	d [mm]	d2 [mm]	Dk [mm]	Dmax(S) [mm]**	Ds [mm]	H [mm]	H2 [mm]	Z (Stroke) [mm]
FGA 13 PVC-50 N016	12.8	4.0	6.6	7.9	15	12.9	15.0	6.6	6
FGA 19 PVC-50 N056	19.0	6.6	12.2	13.0	22	19.0	18.7	8.2	6
FGA 22 PVC-50 N016	24.2	4.8	11.5	10.0	25	21.5	19.0	9.0	7

\*Acceptable dimensional tolerances for rubber parts concerning to DIN ISO 3302-1 M3

\*\*External dimension of the suction cup when it is pressed against the workpiece by the vacuum



Schmalz - The Company  
 Vacuum Suction Cups  
 Special Grippers  
 Gripping Systems  
 Clamping Systems  
 Mounting Elements  
 Vacuum Generators  
 Valve Technology  
 Switches and Monitoring  
 Filters and Connections  
 Services  
 Contact  
 Glossary  
 Index of Products



# Bellows Suction Cups FG PVC (2.5 Folds)

Suction area (Ø) from 18 mm to 50 mm



## Suitability for Industry Specific Applications



Bellows Suction Cups FG PVC (2.5 Folds)

## Applications

- Round, bellows suction cup with 2.5 folds for handling of extremely fragile workpieces thanks to damping effect of folds and soft sealing lip
- Usage in box openers and for handling of non-rigid workpieces and soft packaging materials
- Handling tasks in special processes which use chlorinated water, such as rinsing of plastic bags

## Design

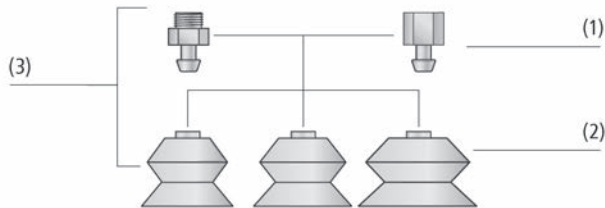

System Design Bellows Suction Cups FG PVC (2.5 Folds)

- Robust and wear-resistant suction cup FG (2) with 2.5 folds and single sealing lip
- Very adaptable geometry and soft, flexible material
- Large effective internal diameter
- With each nipple family, the replacement cups and nipples (1) can be combined as desired (3)



Bellows suction cups FG PVC being used for handling small cardboard boxes

## Our Highlights...

- 2.5 folds
- Large effective internal diameter
- Soft and flexible sealing lip
- Wear-resistant material PVC

## Your Benefits...

- Good damping when positioning on workpiece
- High suction force
- Good adaptation to curved or uneven surfaces
- Long operating lifetime, use for FDA and BfR compliance requirements

# Bellows Suction Cups FG PVC (2.5 Folds)

Suction area (Ø) from 18 mm to 50 mm



## Designation Code Bellows Suction Cups FG PVC (2.5 Folds)

<b>FG</b>	-	<b>32</b>	-	<b>PVC-50</b>	-	<b>N058</b>
<b>1</b>		<b>2</b>		<b>3</b>		<b>4</b>

### 1 – Abbreviated designation

Code	Version
FG	2.5 folds

### 2 – Suction area

Code	Diameter in mm
18...50	ø 18 to 50

### 3 – Material

Code	Material
PVC-50	Polyvinylchloride

### 4 – Connection

Code	Connection
N016	N016
N033	N033
N057	N057
N058	N058

Suction cup FG PVC (elastomer part) is supplied as an individual part.

In order to receive a complete suction cup (elastomer part + connection nipple), the following ordering steps are required:

- Suction cup of type FG PVC – elastomer part, available in various diameters
- Connection nipple of type SA-NIP – available with various threads



## Ordering Data Bellows Suction Cups FG PVC (2.5 Folds)

Type*	Part no.
FG 18 PVC-50 N016	10.01.06.01941
FG 23 PVC-50 N057	10.01.06.01942
FG 32 PVC-50 N058	10.01.06.01943
FG 40 PVC-50 N033	10.01.06.02468
FG 50 PVC-50 N033	10.01.06.02469

\*Additional material specifications at beginning of the section "Vacuum Suction Cups"



## Ordering Data Accessories Bellows Suction Cups FG PVC (2.5 Folds)

Type	Accessories	M5-AG	G1/8-AG	G1/8-IG	G1/4-AG	G1/4-IG
FG 18	Suction cup connection nipple	10.01.06.00123	10.01.06.05735	10.01.06.05731	-	-
FG 23	Suction cup connection nipple	-	10.01.06.03573	10.01.06.03574	-	-
FG 32	Suction cup connection nipple	-	10.01.06.02249	-	-	-
FG 40	Suction cup connection nipple	-	-	-	10.01.01.00818	10.01.01.00817
FG 50	Suction cup connection nipple	-	-	-	10.01.01.00818	10.01.01.00817

# Bellows Suction Cups FG PVC (2.5 Folds)

Suction area (Ø) from 18 mm to 50 mm

## Technical Data Bellows Suction Cups FG PVC (2.5 Folds)

Type	Pull-off force [N]	Suction force [N]*	Volume [cm³]	Workpiece radius min. (convex) [mm]	Hose diameter (recom.) d [mm]	Nipple family**
FG 18 PVC-50 N016	8	3.2	2.0	15	4	N 016
FG 23 PVC-50 N057	15	6.6	3.9	20	4	N 057
FG 32 PVC-50 N058	24	13.9	9.0	30	6	N 058
FG 40 PVC-50 N033	56	21.7	15.3	60	6	N 033
FG 50 PVC-50 N033	68	36.6	28.4	75	6	N 033

\*The specified suction forces are theoretical values at a vacuum of -0.6 bar and with a smooth, dry workpiece surface - they do not include a safety factor

\*\*The recommended hose diameter refers to a hose length of approx. 2 m

## Design Data Bellows Suction Cups FG PVC (2.5 Folds)

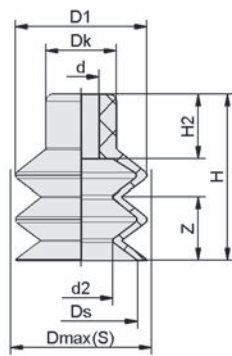

FG 18 PVC-50

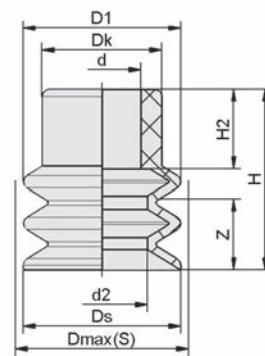

FG 23 PVC-50

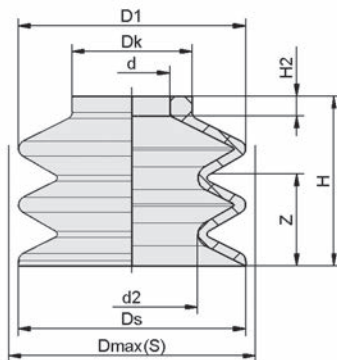

FG 32 PVC-50

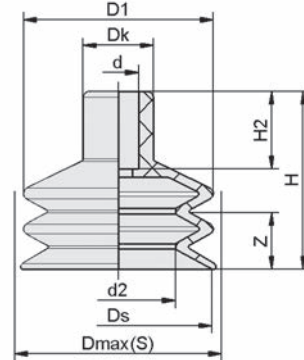

FG 40, 50 PVC-50

Type*	D1 [mm]	d [mm]	d2 [mm]	Dk [mm]	Dmax(S) [mm]**	Ds [mm]	H [mm]	H2 [mm]	Z (Stroke) [mm]
FG 18 PVC-50 N016	18.6	5.0	8.9	10	20.0	16.0	23.5	9.2	9
FG 23 PVC-50 N057	22.3	11.0	12.9	17	25.0	22.3	25.5	11.3	10
FG 32 PVC-50 N058	32.2	10.7	18.6	17	33.5	32.2	24.0	2.8	15
FG 40 PVC-50 N033	40.4	10.8	23.4	19	44.0	40.0	41.7	20.7	11
FG 50 PVC-50 N033	50.5	10.8	30.4	19	54.0	50.0	47.2	20.7	16

\*Acceptable dimensional tolerances for rubber parts concerning to DIN ISO 3302-1 M3

\*\*External dimension of the suction cup when it is pressed against the workpiece by the vacuum



Schmalz – The Company  
 Vacuum Suction Cups  
 Special Grippers  
 Gripping Systems  
 Clamping Systems  
 Mounting Elements  
 Vacuum Generators  
 Valve Technology  
 Switches and Monitoring  
 Filters and Connections  
 Services  
 Contact  
 Glossary  
 Index of Products

# Chocolate Suction Cups SPG

Suction area (Ø) 33 mm



## Suitability for Industry Specific Applications

### Applications

- Bell-shaped suction cup for dynamic handling and packing of chocolates in combination with picker robots
- Direct handling of round, oval or square chocolates
- Handling of confectionery with structured surfaces or toppings
- Suitable for direct contact with food due to FDA compliant material silicone
- Handling of round chocolates with maximum diameter of 35 mm and oval / square chocolates with maximum diagonal measurement of 30 mm

### Design

- Suction cup (1) with extremely thin, soft sealing lip and tapered suction cup geometry
- Optimal sealing lip shape for handling workpieces with structured surfaces
- Use of one-piece insertable connection element (2), with G1/8" male or female thread, for changing the suction cup quickly
- Connection element with male thread has an integrated seal



Chocolate Suction Cups SPG

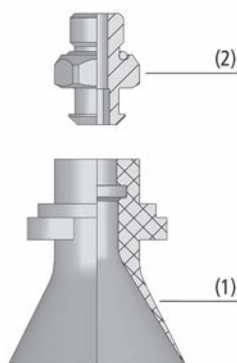

System Design Chocolate Suction Cups SPG



Chocolate suction cups SPG being used for handling chocolates

### Our Highlights...

- Extremely thin sealing lip
- Tapered sealing lip shape
- Large nominal flow
- FDA compliant material silicone

### Your Benefits...

- Good sealing on decorated chocolates
- Even square chocolates are enclosed by suction cup; dynamic handling possible
- Leakage compensation on highly-structured chocolates
- Suitable for direct contact with food

Schmalz – The Company

Vacuum Suction Cups

Special Grippers

Gripping Systems

Clamping Systems

Mounting Elements

Vacuum Generators

Valve Technology

Switches and Monitoring

Filters and Connections

Services

Contact

Glossary

Index of Products



# Chocolate Suction Cups SPG

Suction area (Ø) 33 mm



## Designation Code Chocolate Suction Cups SPG

<b>SPG</b>	-	<b>33</b>	-	<b>SI-45</b>	-	<b>SC040</b>
1		2		3		4

### 1 – Abbreviated designation

Code	Version
SPG	Bell-shaped

### 2 – Suction area

Code	Diameter in mm
33	ø 33

### 3 – Material

Code	Material
SI-45	Silicone
SI-HD	Silicone

### 4 – Connection

Code	Connection
SC040	SC040

Chocolate suction cup SPG (elastomer part) is supplied as an individual part.

In order to receive a complete suction cup (elastomer part + connection element), the following ordering steps are required:

- Suction cup of type SPG – elastomer part
- Connection element of type SC – available with various threads



## Ordering Data Chocolate Suction Cups SPG

Type*	Part no.
SPG 33 SI-45 SC040	10.01.19.00002
SPG 33 SI-HD SC040	10.01.19.00165

\*Additional material specifications at beginning of the section "Vacuum Suction Cups"



## Ordering Data Accessories Chocolate Suction Cups SPG

SC 040 G1/8-AG	SC 040 G1/8-IG
10.01.06.02490	10.01.06.02482



## Technical Data Chocolate Suction Cups SPG

Type	Volume [cm³]	Hose diameter (recom.) d [mm]*	Nipple family
SPG 33 SI-45 SC040	8.1	4	SC 040
SPG 33 SI-HD SC040	8.1	4	SC 040

\*The suction force and operating vacuum are dependent on the geometry and surface characteristics of the chocolate. We recommend a maximum operating vacuum of -150 mbar.

# Chocolate Suction Cups SPG

Suction area (Ø) 33 mm



## Design Data Chocolate Suction Cups SPG

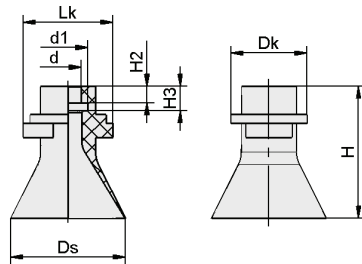

SPG

Type*	d [mm]	d1 [mm]	Dk [mm]	Ds [mm]	H [mm]	H2 [mm]	H3 [mm]	Lk [mm]
SPG 33 SI-45 SC040	7.3	11	21.5	32.1	38	4.8	7	25.5
SPG 33 SI-HD SC040	7.3	11	21.5	32.1	38	4.8	7	25.5

\*Acceptable dimensional tolerances for rubber parts concerning to DIN ISO 3302-1 M3

- Schmalz – The Company
- Vacuum Suction Cups
- Special Grippers
- Gripping Systems
- Clamping Systems
- Mounting Elements
- Vacuum Generators
- Valve Technology
- Switches and Monitoring
- Filters and Connections
- Services
- Contact
- Glossary
- Index of Products



# Flat Suction Cups SGPN

Suction area (Ø) from 15 mm to 40 mm



Flat Suction Cups SGPN

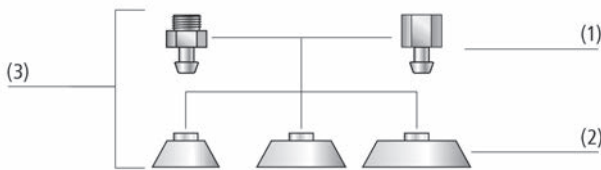

System Design Flat Suction Cups SGPN

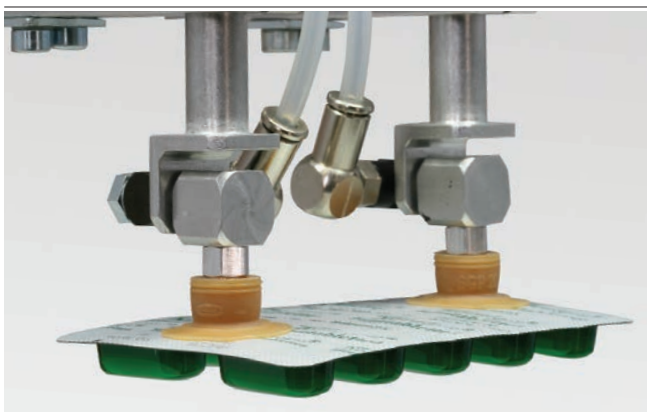

Flat suction cups SGPN being used for handling blister packagings

## Suitability for Industry Specific Applications

### Applications

- Round, flat suction cup for handling of wooden veneers, wafers and solar cells
- Handling of various packing material, e.g. plastic films, paper, blister packs
- Gentle handling of plastic films and paper due to flat, long-tapered sealing lip and inner support

### Design

- Robust, wear-resistant suction cup SGPN (3) with single sealing lip, consisting of suction cup SGP (2) and connection nipple (1)
- Nipple plugged into cup
- With each nipple family, the replacement cups and nipples can be combined as desired

### Our Highlights...

- Flat, long-tapered sealing lip and inner support
- Material: natural rubber NK 40 Shore A
- Material: Silicone SI 50 Shore A
- Material: HT1

### Your Benefits...

- No pulling-in to the suction cup, i.e. very suitable for plastic film, paper and solar cells
- No crinkling when gripping paper and plastic film
- Resistant to ozone, UV radiation and heat
- No marks on the workpiece

# Flat Suction Cups SGPN

Suction area (Ø) from 15 mm to 40 mm



## Designation Code Flat Suction Cups SGPN



### 1 – Abbreviated designation

Code	Version
SGPN	Flat

### 2 – Suction area

Code	Diameter in mm
15...40	ø 15 to 40

### 3 – Material

Code	Material
FPM-65	Fluorcaoutchuc
HT1-60	High temperature material
NK-40	Natural rubber
SI-50	Silicone

### 4 – Connection

Code	Connection
M5-AG	M5-AG (AG = male (M))
G1/8-AG	G1/8-AG
G1/8-IG	G1/8-IG (IG = female (F))
G1/4-AG	G1/4-AG
G1/4-IG	G1/4-IG

Flat suction cup SGPN (elastomer part + connection nipple) is delivered unassembled. The delivery consists of:

- Suction cup of type SGP – elastomer part, available in various diameters and materials
- Connection nipple of type SA-NIP – available with various threads

Available spare parts: suction cup SGP, connection nipple SA-NIP



## Ordering Data Flat Suction Cups SGPN

Type			Suction cup material with ShA: *			
			FPM-65	HT1-60	NK-40	SI-50
SGPN	15	M5-AG	-	10.01.01.12396	10.01.01.11977	10.01.01.11980
SGPN	15	G1/8-AG	10.01.01.12921	10.01.01.12397	10.01.01.10315	10.01.01.11981
SGPN	15	G1/8-IG	10.01.01.13047	10.01.01.12398	10.01.01.10181	10.01.01.11982
SGPN	20	M5-AG	-	-	10.01.01.11978	10.01.01.11983
SGPN	20	G1/8-AG	10.01.01.12922	-	10.01.01.10316	10.01.01.11984
SGPN	20	G1/8-IG	10.01.01.13048	-	10.01.01.10180	10.01.01.11985
SGPN	24	M5-AG	-	10.01.01.12403	10.01.01.11979	10.01.01.11986
SGPN	24	G1/8-AG	-	10.01.01.12404	10.01.01.10317	10.01.01.11987
SGPN	24	G1/8-IG	-	10.01.01.12405	10.01.01.10182	10.01.01.11988
SGPN	30	G1/4-AG	-	10.01.01.12399	10.01.01.00791	10.01.01.11989
SGPN	30	G1/4-IG	-	10.01.01.12400	10.01.01.00790	10.01.01.11990
SGPN	34	G1/4-AG	10.01.01.12920	-	10.01.01.10831	-
SGPN	34	G1/4-IG	10.01.01.13046	-	10.01.01.10830	-
SGPN	35	G1/4-AG	-	10.01.01.12848	10.01.01.00793	10.01.01.12785
SGPN	35	G1/4-IG	-	10.01.01.12849	10.01.01.00792	10.01.01.12787
SGPN	40	G1/8-AG	-	10.01.01.12847	10.01.01.11739	10.01.01.12773
SGPN	40	G1/4-AG	-	10.01.01.12845	10.01.01.00795	10.01.01.12775
SGPN	40	G1/4-IG	-	10.01.01.12846	10.01.01.00794	10.01.01.12774

\*Additional material specifications at beginning of the section "Vacuum Suction Cups"



Schmalz – The Company

Vacuum Suction Cups

Special Grippers

Gripping Systems

Clamping Systems

Mounting Elements

Vacuum Generators

Valve Technology

Switches and Monitoring

Filters and Connections

Services

Contact

Glossary

Index of Products



# Flat Suction Cups SGPN

Suction area ( $\varnothing$ ) from 15 mm to 40 mm

## Ordering Data Spare Parts Flat Suction Cups SGPN

Type	Suction cup material with ShA: *			
	FPM-65	HT1-60	NK-40	SI-50
SGP 15	10.01.01.12908	10.01.01.12394	10.01.01.10318	10.01.01.10574
SGP 20	10.01.01.12909	-	10.01.01.10319	10.01.01.11571
SGP 24	-	10.01.01.12402	10.01.01.10320	10.01.01.10577
SGP 30	-	10.01.01.12395	10.01.01.00787	10.01.01.01064
SGP 34	10.01.01.12919	-	10.01.01.10829	-
SGP 35	-	10.01.01.12811	10.01.01.00788	10.01.01.12784
SGP 40	-	10.01.01.12812	10.01.01.00789	10.01.01.12772

\*Additional material specifications at beginning of the section "Vacuum Suction Cups"

Type	Spare Parts		Part no.
SGPN 15 M5-AG	Suction cup connection nipple	SA-NIP N016 M5-AG DN250	10.01.06.00123
SGPN 15 G1/8-AG	Suction cup connection nipple	SA-NIP N016 G1/8-AG DN350	10.01.06.05735
SGPN 15 G1/8-IG	Suction cup connection nipple	SA-NIP N016 G1/8-IG DN350	10.01.06.05731
SGPN 20 M5-AG	Suction cup connection nipple	SA-NIP N016 M5-AG DN250	10.01.06.00123
SGPN 20 G1/8-AG	Suction cup connection nipple	SA-NIP N016 G1/8-AG DN350	10.01.06.05735
SGPN 20 G1/8-IG	Suction cup connection nipple	SA-NIP N016 G1/8-IG DN350	10.01.06.05731
SGPN 24 M5-AG	Suction cup connection nipple	SA-NIP N016 M5-AG DN250	10.01.06.00123
SGPN 24 G1/8-AG	Suction cup connection nipple	SA-NIP N016 G1/8-AG DN350	10.01.06.05735
SGPN 24 G1/8-IG	Suction cup connection nipple	SA-NIP N016 G1/8-IG DN350	10.01.06.05731
SGPN 30 G1/4-AG	Suction cup connection nipple	SA-NIP N033 G1/4-AG DN550	10.01.01.00818
SGPN 30 G1/4-IG	Suction cup connection nipple	SA-NIP N033 G1/4-IG DN550	10.01.01.00817
SGPN 34 G1/4-AG	Suction cup connection nipple	SA-NIP N033 G1/4-AG DN550	10.01.01.00818
SGPN 34 G1/4-IG	Suction cup connection nipple	SA-NIP N033 G1/4-IG DN550	10.01.01.00817
SGPN 35 G1/4-AG	Suction cup connection nipple	SA-NIP N034 G1/4-AG DN550	10.01.01.00820
SGPN 35 G1/4-IG	Suction cup connection nipple	SA-NIP N034 G1/4-IG DN550	10.01.01.00819
SGPN 40 G1/8-AG	Suction cup connection nipple	SA-NIP N035 G1/8-AG DN500	10.01.01.11738
SGPN 40 G1/4-AG	Suction cup connection nipple	SA-NIP N035 G1/4-AG DN550	10.01.01.00822
SGPN 40 G1/4-IG	Suction cup connection nipple	SA-NIP N035 G1/4-IG DN550	10.01.01.00821



## Technical Data Flat Suction Cups SGPN

Type	Suction force [N]*	Volume [cm <sup>3</sup> ]	Hose diameter (recom.) d [mm]**	Nipple family
SGPN 15	5.5	0.28	2	N 016
SGPN 20	8.5	0.60	2	N 016
SGPN 24	11.0	0.86	4	N 016
SGPN 30	19.0	3.00	4	N 033
SGPN 34	25.0	3.70	4	N 033
SGPN 35	31.0	2.80	4	N 034
SGPN 40	33.0	3.80	4	N 035

\*The specified suction forces are theoretical values at a vacuum of -0.6 bar and with a smooth, dry workpiece surface - they do not include a safety factor

\*\*The recommended hose diameter refers to a hose length of approx. 2 m

# Flat Suction Cups SGPN

Suction area ( $\varnothing$ ) from 15 mm to 40 mm



## Design Data Flat Suction Cups SGPN

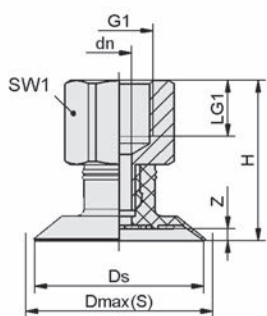

SGPN 15 - 40 IG

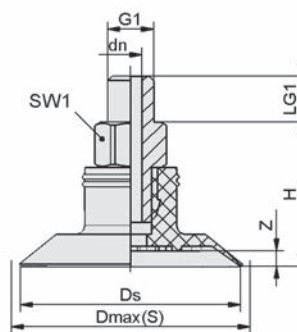

SGPN 15 - 40 AG

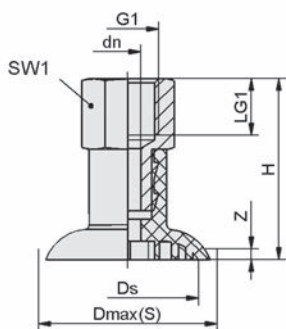

SGPN 35 IG

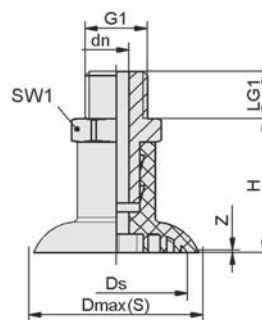

SGPN 35 AG

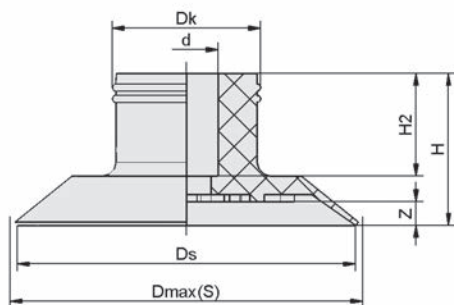

SGP 15 - 40

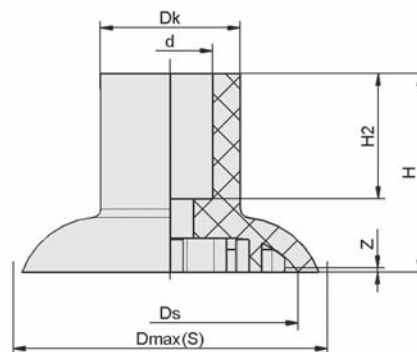

SGP 35



# Flat Suction Cups SGPN

Suction area (Ø) from 15 mm to 40 mm



## Design Data Flat Suction Cups SGPN

Type*			dn [mm]	Dmax(S) [mm]**	Ds [mm]	G1	H [mm]	LG1 [mm]	SW1 [mm]	Z (Stroke) [mm]
SGPN	15	M5-AG	2.5	15.5	14.5	M5-M	15.0	5	7	0.9
SGPN	15	G1/8-AG	3.5	15.5	14.5	G1/8"-M	16.0	8	14	0.9
SGPN	15	G1/8-IG	3.5	15.5	14.5	G1/8"-F	22.0	8	14	0.9
SGPN	20	M5-AG	2.5	22.0	20.0	M5-M	15.4	5	7	1.5
SGPN	20	G1/8-AG	3.5	22.0	20.0	G1/8"-M	16.4	8	14	1.5
SGPN	20	G1/8-IG	3.5	22.0	20.0	G1/8"-F	22.4	8	14	1.5
SGPN	24	M5-AG	2.5	25.5	24.0	M5-M	15.8	5	7	1.7
SGPN	24	G1/8-AG	3.5	25.5	24.0	G1/8"-M	16.8	8	14	1.7
SGPN	24	G1/8-IG	3.5	25.5	24.0	G1/8"-F	22.8	8	14	1.7
SGPN	30	G1/4-AG	5.5	32.0	30.0	G1/4"-M	27.2	10	17	2.0
SGPN	30	G1/4-IG	5.5	32.0	30.0	G1/4"-F	37.2	12	17	2.0
SGPN	34	G1/4-AG	5.5	37.5	34.0	G1/4"-M	28.0	10	17	2.2
SGPN	34	G1/4-IG	5.5	37.5	34.0	G1/4"-F	38.0	12	17	2.2
SGPN	35	G1/4-AG	5.5	35.0	34.0	G1/4"-M	28.5	10	17	0.5
SGPN	35	G1/4-IG	5.5	35.0	34.0	G1/4"-F	38.5	12	17	0.5
SGPN	40	G1/8-AG	5.0	42.0	40.0	G1/8"-M	25.6	10	17	2.3
SGPN	40	G1/4-AG	5.0	42.0	40.0	G1/4"-M	25.6	10	17	2.3
SGPN	40	G1/4-IG	5.0	42.0	40.0	G1/4"-F	35.6	12	17	2.3

\*Acceptable dimensional tolerances for rubber parts concerning to DIN ISO 3302-1 M3

\*\*External dimension of the suction cup when it is pressed against the workpiece by the vacuum

Type*		d [mm]	Dk [mm]	Dmax(S) [mm]**	Ds [mm]	H [mm]	H2 [mm]	Z (Stroke) [mm]
SGP	15	4.5	9.5	15.5	14.5	10.0	7.2	0.9
SGP	20	4.5	11.0	22.0	20.0	10.4	7.1	1.5
SGP	24	4.5	10.5	25.5	24.0	10.8	7.3	1.7
SGP	30	11.2	15.6	32.0	30.0	22.2	15.7	2.0
SGP	35	10.0	16.5	35.0	30.2	23.5	14.8	0.5
SGP	34	11.2	15.2	37.5	34.0	23.0	16.8	2.2
SGP	40	8.0	16.0	42.0	40.0	20.6	14.5	2.3

\*Acceptable dimensional tolerances for rubber parts concerning to DIN ISO 3302-1 M3

\*\*External dimension of the suction cup when it is pressed against the workpiece by the vacuum

# Suction Plates SGF

Suction area (Ø) from 125 mm to 400 mm



## Suitability for Industry Specific Applications

### Applications

- Suction plates for handling of flat and smooth workpieces such as glass and plastic sheets where high lateral forces are important, e.g. through high accelerations or vertical handling
- Handling of very thin workpieces, such as flat glass (float glass) or coated glass
- Used in glass manufacturing processes where interleaved powder is used
- Handling of solar modules, e.g. in module manufacturing processes

### Design

- Aluminum support plate (1) and sealing ring (2)
- Diameters 125 mm to 200 mm: replaceable sealing ring and thin, flat sealing lip
- Diameters 250 mm to 400 mm: vulcanized sealing ring and steep sealing lip
- Central vacuum connection, optionally with clip-in filter screen (3) as pre-filter
- Eccentric connection for touch valve (4) or filter screen (5), as a standard closed with a plug (secured with adhesive)
- Special designed internal structure for handling glass sheets when interleaved powder is used in the process

### Our Highlights...

- Thin and flat sealing lip (Ø 125 mm to 200 mm)
- Steep sealing lip (Ø 250 mm to 400 mm)
- Low total weight of the suction plate
- Large effective suction area

### Your Benefits...

- Little relative movement during pick-up; this prevents the surface of the workpiece from being damaged
- Optimum pick-up characteristics and damping effect
- High accelerations in automated processes
- High suction and lateral forces in dynamic processes



Suction Plates SGF

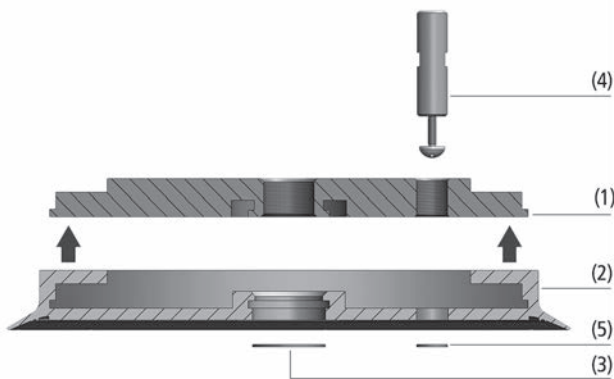

System Design Suction Plates SGF



Suction plates SGF being used for handling sensitive glass sheets

# Suction Plates SGF

Suction area (Ø) from 125 mm to 400 mm



## Designation Code Suction Plates SGF

<b>SGF</b>	-	<b>HS</b>	-	<b>150</b>	-	<b>EPDM-55</b>	-	<b>G1/2-IG</b>
1		2		3		4		5

### 1 – Abbreviated designation

Code	Version
SGF	Flat

### 2 – Product addition

Code	Type
HS	High stroke

### 3 – Suction area

Code	Diameter in mm
125...400	Ø 125 to 400

### 4 – Material

Code	Material
EPDM-55	Ethylene-propylene-caoutchuc
HT1-60	High temperature material

### 5 – Connection

Code	Connection
G1/4-IG	G1/4-IG (IG = female (F))
G1/2-IG	G1/2-IG
FM1	FM1

Suction plate SGF (sealing ring + support plate) is delivered assembled. The assembly consists of:

- Sealing ring of type DR-SGF – elastomer part, available in various diameters
- Aluminum support plate – available with various threads

Available spare parts: sealing ring of type DR-SGF

Available accessories: touch valve, filter screen (sieve, round)



## Ordering Data Suction Plates SGF

Type*	Part no.
SGF 125 EPDM-55 G1/4-IG	10.01.01.12475
SGF 125 HT1-60 G1/4-IG	10.01.01.12892
SGF 150 EPDM-55 G1/2-IG	10.01.01.13019
SGF 150 HT1-60 G1/2-IG	10.01.01.13021
SGF 150 HT1-60 FM1	10.01.01.13486
SGF 200 EPDM-55 G1/2-IG	10.01.01.12476
SGF 200 HT1-60 G1/2-IG	10.01.01.12893
SGF 400 EPDM-55 G1/2-IG	10.01.01.12478
SGF-HS 150 EPDM-55 G1/2-IG	10.01.01.13492
SGF-HS 150 EPDM-55 FM1	10.01.01.13503
SGF-HS 150 HT1-60 G1/2-IG	10.01.01.13178
SGF-HS 150 HT1-60 FM1	10.01.01.13490
SGF-HS 250 EPDM-55 G1/2-IG	10.01.01.13038
SGF-HS 250 HT1-60 G1/2-IG	10.01.01.13153
SGF-HS 300 EPDM-55 G1/2-IG	10.01.01.13793
SGF-HS 300 HT1-60 G1/2-IG	10.01.01.13794
SGF-HS 350 EPDM-55 G1/2-IG	10.01.01.13039
SGF-HS 350 HT1-60 G1/2-IG	10.01.01.13154

\*Additional material specifications at beginning of the section "Vacuum Suction Cups"

# Suction Plates SGF

Suction area (Ø) from 125 mm to 400 mm



## Ordering Data Spare Parts Suction Plates SGF

Type			Spare Parts		Part no.
SGF	125	EPDM-55	Sealing ring for SGF suction plate	DR-SGF 125 EPDM-55	10.01.01.12473
SGF	125	HT1-60	Sealing ring for SGF suction plate	DR-SGF 125 HT1-60	10.01.01.12890
SGF	150	EPDM-55	Sealing ring for SGF suction plate	DR-SGF 150 EPDM-55	10.01.01.13018
SGF	150	HT1-60	Sealing ring for SGF suction plate	DR-SGF 150 HT1-60	10.01.01.13020
SGF	200	EPDM-55	Sealing ring for SGF suction plate	DR-SGF 200 EPDM-55	10.01.01.12474
SGF	200	HT1-60	Sealing ring for SGF suction plate	DR-SGF 200 HT1-60	10.01.01.12891
SGF-HS	150	EPDM-55	Sealing ring for SGF suction plate	DR-SGF-HS 150 EPDM-55	10.01.01.13491
SGF-HS	150	HT1-60	Sealing ring for SGF suction plate	DR-SGF-HS 150 HT1-60	10.01.01.13176



## Ordering Data Accessories Suction Plates SGF

Type	Touch Valve	Sieve, round
SGF 125 EPDM-55 G1/4-IG	10.05.10.00061	10.07.01.00215
SGF 125 HT1-60 G1/4-IG	10.05.10.00061	10.07.01.00215
SGF 150 EPDM-55 G1/2-IG	10.05.10.00061	10.07.01.00110
SGF 150 HT1-60 G1/2-IG	10.05.10.00061	10.07.01.00110
SGF 150 HT1-60 FM1	10.05.10.00061	10.07.01.00110
SGF 200 EPDM-55 G1/2-IG	10.05.10.00061	10.07.01.00110
SGF 200 HT1-60 G1/2-IG	10.05.10.00061	10.07.01.00110
SGF 400 EPDM-55 G1/2-IG	10.05.10.00061	10.07.01.00110
SGF-HS 150 EPDM-55 G1/2-IG	10.05.10.00061	10.07.01.00110
SGF-HS 150 EPDM-55 FM1	10.05.10.00061	10.07.01.00110
SGF-HS 150 HT1-60 G1/2-IG	10.05.10.00061	10.07.01.00110
SGF-HS 150 HT1-60 FM1	10.05.10.00061	10.07.01.00110
SGF-HS 250 EPDM-55 G1/2-IG	10.05.10.00061	10.07.01.00110
SGF-HS 250 HT1-60 G1/2-IG	10.05.10.00061	10.07.01.00110
SGF-HS 300 EPDM-55 G1/2-IG	10.05.10.00061	10.07.01.00110
SGF-HS 300 HT1-60 G1/2-IG	10.05.10.00061	10.07.01.00110
SGF-HS 350 EPDM-55 G1/2-IG	10.05.10.00061	10.07.01.00110
SGF-HS 350 HT1-60 G1/2-IG	10.05.10.00061	10.07.01.00110



## Technical Data Suction Plates SGF

Type	Suction force [N]*	Suction force d2 [N]**	Workpiece radius min. (convex) [mm]	Volume [cm³]	Hose diameter (recom.) d [mm]***
SGF 125 EPDM-55 G1/4-IG	730	470	1,500	44	9
SGF 125 HT1-60 G1/4-IG	730	470	1,500	44	9
SGF 150 EPDM-55 G1/2-IG	1,060	730	2,000	65	9
SGF 150 HT1-60 G1/2-IG	1,060	730	2,000	65	9
SGF 150 HT1-60 FM1	1,060	730	2,000	65	9
SGF 200 EPDM-55 G1/2-IG	1,880	1,610	3,500	145	12
SGF 200 HT1-60 G1/2-IG	1,880	1,610	3,500	145	12
SGF 400 EPDM-55 G1/2-IG	7,530	6,520	13,500	560	12
SGF-HS 150 EPDM-55 G1/2-IG	1,060	730	2,000	119	9
SGF-HS 150 EPDM-55 FM1	1,060	730	2,000	119	9
SGF-HS 150 HT1-60 G1/2-IG	1,060	730	2,000	119	9
SGF-HS 150 HT1-60 FM1	1,060	730	2,000	119	9



# Suction Plates SGF

Suction area (Ø) from 125 mm to 400 mm



## Technical Data Suction Plates SGF

Type	Suction force [N]*	Suction force d2 [N]**	Workpiece radius min. (convex) [mm]	Volume [cm³]	Hose diameter (recom.) d [mm]***
SGF-HS 250 EPDM-55 G1/2-IG	2,900	2,220	1,600	372	12
SGF-HS 250 HT1-60 G1/2-IG	2,900	2,220	1,600	372	12
SGF-HS 300 EPDM-55 G1/2-IG	4,240	3,480	2,400	550	12
SGF-HS 300 HT1-60 G1/2-IG	4,240	3,480	2,400	550	12
SGF-HS 350 EPDM-55 G1/2-IG	5,700	4,730	3,000	780	12
SGF-HS 350 HT1-60 G1/2-IG	5,700	4,730	3,000	780	12

\*The specified suction forces are theoretical values at a vacuum of -0.6 bar and with a smooth, dry workpiece surface - they do not include a safety factor

\*\*Suction force referred to the sealing-edge diameter d2

\*\*\*The recommended hose diameter refers to a hose length of approx. 2 m



## Design Data Suction Plates SGF

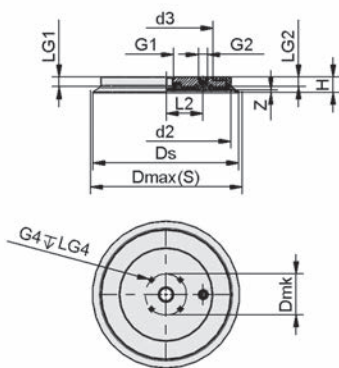

SGF 125 - 200

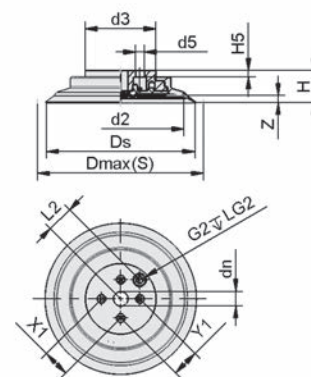

SGF-HS 150

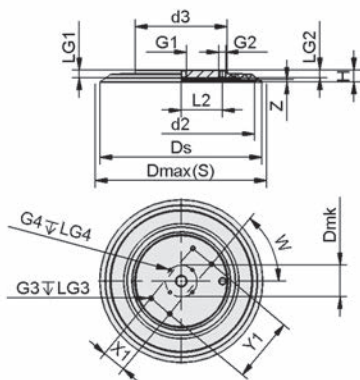

SGF 250 - 400

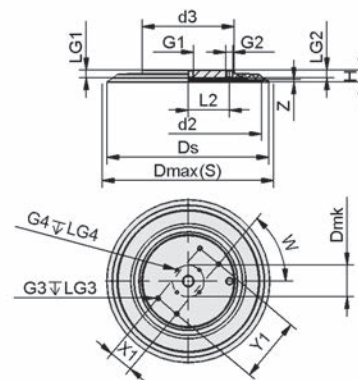

SGF-HS 250 - 350

# Suction Plates SGF

Suction area (Ø) from 125 mm to 400 mm



## Design Data Suction Plates SGF

Type*	d2 [mm]	d3 [mm]	d5 [mm]	Dmax(S) [mm]**	Dmk [mm]	dn [mm]	Ds [mm]	G1	G2	G3	G4
SGF 125 EPDM-55 G1/4-IG	100.0	70	-	130	59	-	123	G1/4"-F	G1/4"-F	-	M6-F
SGF 125 HT1-60 G1/4-IG	100.0	70	-	130	59	-	123	G1/4"-F	G1/4"-F	-	M6-F
SGF 150 EPDM-55 G1/2-IG	125.0	93	-	156	59	-	149	G1/2"-F	G1/4"-F	-	M6-F
SGF 150 HT1-60 G1/2-IG	125.0	93	-	156	59	-	149	G1/2"-F	G1/4"-F	-	M6-F
SGF 150 HT1-60 FM1	125.0	93	-	156	-	-	149	-	G1/4"-F	-	-
SGF 200 EPDM-55 G1/2-IG	185.0	134	-	213	59	-	206	G1/2"-F	G1/4"-F	-	M6-F
SGF 200 HT1-60 G1/2-IG	185.0	134	-	213	59	-	206	G1/2"-F	G1/4"-F	-	M6-F
SGF 400 EPDM-55 G1/2-IG	372.3	170	-	405	59	-	398	G1/2"-F	G1/4"-F	M8-F	M6-F
SGF-HS 150 EPDM-55 G1/2-IG	126.0	70	-	165	59	-	149	G1/2"-F	G1/4"-F	-	M6-F
SGF-HS 150 EPDM-55 FM1	126.0	70	9	165	-	14.5	149	-	G1/2"-F	-	-
SGF-HS 150 HT1-60 G1/2-IG	126.0	70	-	165	59	-	149	G1/2"-F	G1/4"-F	-	M6-F
SGF-HS 150 HT1-60 FM1	126.0	70	9	165	-	14.5	149	-	G1/4"-F	-	-
SGF-HS 250 EPDM-55 G1/2-IG	217.0	140	-	260	59	-	248	G1/2"-F	G1/4"-F	M8-F	M6-F
SGF-HS 250 HT1-60 G1/2-IG	217.0	140	-	260	59	-	248	G1/2"-F	G1/4"-F	M8-F	M6-F
SGF-HS 300 EPDM-55 G1/2-IG	272.3	170	-	309	-	-	304	G1/2"-F	-	-	-
SGF-HS 300 HT1-60 G1/2-IG	272.3	170	-	309	-	-	304	G1/2"-F	G1/4"-F	M8-F	M6-F
SGF-HS 350 EPDM-55 G1/2-IG	317.0	170	-	360	59	-	348	G1/2"-F	G1/4"-F	M8-F	M6-F
SGF-HS 350 HT1-60 G1/2-IG	317.0	170	-	360	59	-	348	G1/2"-F	G1/4"-F	M8-F	M6-F

\*Acceptable dimensional tolerances for rubber parts concerning to DIN ISO 3302-1 M3

\*\*External dimension of the suction cup when it is pressed against the workpiece by the vacuum

Type	H [mm]	H5 [mm]	LG1 [mm]	LG2 [mm]	LG3 [mm]	LG4 [mm]	L2 [mm]	W [mm]	X1 [mm]	Y1 [mm]	Z (Stroke) [mm]
SGF 125 EPDM-55 G1/4-IG	21.4	-	14	14	-	11	27	-	-	-	3
SGF 125 HT1-60 G1/4-IG	21.4	-	14	14	-	11	27	-	-	-	3
SGF 150 EPDM-55 G1/2-IG	21.7	-	14	14	-	11	37	-	-	-	4
SGF 150 HT1-60 G1/2-IG	21.7	-	14	14	-	11	37	-	-	-	4
SGF 150 HT1-60 FM1	27.7	-	-	20	-	-	37	-	27	27	4
SGF 200 EPDM-55 G1/2-IG	22.0	-	14	14	-	11	53	-	-	-	4
SGF 200 HT1-60 G1/2-IG	22.0	-	14	14	-	11	53	-	-	-	4
SGF 400 EPDM-55 G1/2-IG	22.3	-	15	15	12	11	76	50	45	120	5
SGF-HS 150 EPDM-55 G1/2-IG	25.9	-	14	14	-	11	27	-	-	-	8
SGF-HS 150 EPDM-55 FM1	31.9	6	-	20	-	-	27	-	27	27	8
SGF-HS 150 HT1-60 G1/2-IG	25.9	-	14	14	-	11	27	-	-	-	8
SGF-HS 150 HT1-60 FM1	31.9	6	-	20	-	-	27	-	27	27	8
SGF-HS 250 EPDM-55 G1/2-IG	26.8	-	15	15	12	11	53	70	45	100	9
SGF-HS 250 HT1-60 G1/2-IG	26.8	-	15	15	12	11	53	70	45	100	9
SGF-HS 300 EPDM-55 G1/2-IG	26.8	-	15	15	12	11	76	50	45	120	9
SGF-HS 300 HT1-60 G1/2-IG	26.8	-	15	15	12	11	76	50	45	120	9
SGF-HS 350 EPDM-55 G1/2-IG	26.8	-	15	15	12	11	76	50	45	120	9
SGF-HS 350 HT1-60 G1/2-IG	26.8	-	15	15	12	11	76	50	45	120	9



Schmalz - The Company  
 Vacuum Suction Cups  
 Special Grippers  
 Gripping Systems  
 Clamping Systems  
 Mounting Elements  
 Vacuum Generators  
 Valve Technology  
 Switches and Monitoring  
 Filters and Connections  
 Services  
 Contact  
 Glossary  
 Index of Products



# Bellows Suction Cups SAB HT1 (1.5 Folds)

Suction area (Ø) from 22 mm to 125 mm



## Suitability for Industry Specific Applications



Bellows Suction Cups SAB HT1 (1.5 Folds)

## Applications

- Round bellows suction cup with 1.5 folds for dynamic handling of glass workpieces
- Handling of flat glass and formed glass pieces
- Use in automated production lines for automotive windscreens or side windows, even after the bending process at temperatures up to 170° C
- Exact positioning in production processes without displacement
- High lateral forces in use with separation powder on flat glass or on damp surfaces

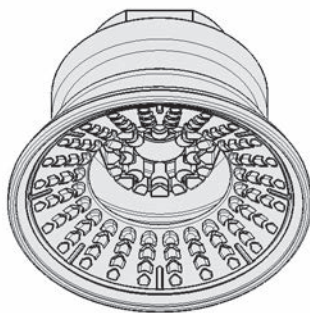

System Design Bellows Suction Cups SAB HT1 (1.5 Folds)

## Design

- Robust and hard-wearing bellows suction cup made of HT1 with 1.5 folds, with special slot and inner support
- Suction cup is vulcanized to the connection nipple (for very high strength)
- Special structure of the suction surface with high performance profile

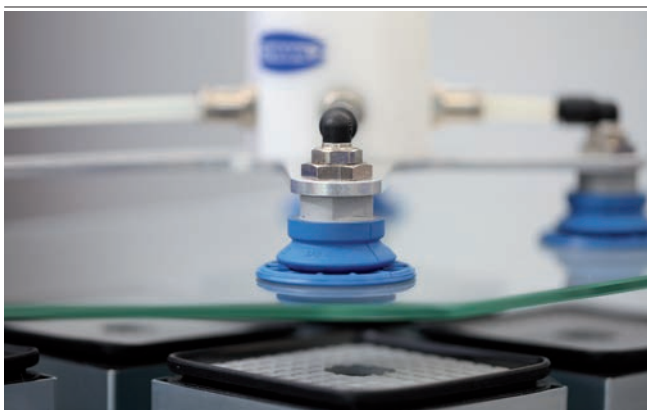

Bellows suction cups SAB HT1 being used for handling glass

## Our Highlights...

- Non-marking material HT1
- High temperature resistance
- Large, structured inner support

## Your Benefits...

- Minimal chemical influence on the workpiece surface
- Handling of hot workpieces without modification of the material properties
- Capable of handling high lateral forces, especially in use with separating powder and wet workpieces



# Bellows Suction Cups SAB HT1 (1.5 Folds)

Suction area (Ø) from 22 mm to 125 mm



## Designation Code Bellows Suction Cups SAB HT1 (1.5 Folds)

<b>SAB</b>	-	<b>30</b>	-	<b>HT1-60</b>	-	<b>G1/4-AG</b>
<b>1</b>		<b>2</b>		<b>3</b>		<b>4</b>

### 1 – Abbreviated designation

Code	Version
SAB	1.5 folds

### 2 – Suction area

Code	Diameter in mm
22...125	ø 22 to 125

### 3 – Material

Code	Material
HT1-60	High temperature material

### 4 – Connection

Code	Connection
G1/4-AG	G1/4-AG (AG = male (M))
G1/4-IG	G1/4-IG (IG = female (F))
G3/8-AG	G3/8-AG
G3/8-IG	G3/8-IG
RA	Rectangular adapter

Suction cup SAB HT1, available in various diameters, is delivered with connection nipple vulcanized to elastomer part.



## Ordering Data Bellows Suction Cups SAB HT1 (1.5 Folds)

Type	Vacuum connection:				
	G1/4-M	G1/4-F	G3/8-M	G3/8-F	Rectangular adapter
SAB 22	10.01.06.02753	10.01.06.02722	10.01.06.03015	10.01.06.03006	-
SAB 30	10.01.06.03048	10.01.06.02723	10.01.06.03049	10.01.06.03050	10.01.06.02755
SAB 40	10.01.06.03051	10.01.06.02724	10.01.06.03052	10.01.06.03053	10.01.06.02757
SAB 50	10.01.06.03057	10.01.06.02760	10.01.06.03058	10.01.06.02725	10.01.06.02759
SAB 60	10.01.06.03059	10.01.06.02779	10.01.06.03060	10.01.06.02726	10.01.06.02762
SAB 80	10.01.06.03061	10.01.06.02778	10.01.06.03062	10.01.06.02727	10.01.06.02764
SAB 100	10.01.06.02927	10.01.06.02961	10.01.06.03063	10.01.06.02728	10.01.06.02766
SAB 125	10.01.06.03065	10.01.06.03064	10.01.06.03066	10.01.06.02729	-



## Technical Data Bellows Suction Cups SAB HT1 (1.5 Folds)

Type	Suction force [N]*	Pull-off force [N]	Lateral force [N]**	Volume [cm³]	Workpiece radius min. (convex) [mm]	Hose diameter (recom.) d [mm]***
SAB 22	16	24	18	1.5	20	4
SAB 30	22	33	30	5.9	40	4
SAB 40	38	59	36	7.0	40	4
SAB 50	53	87	55	11.5	50	4
SAB 60	82	130	82	24.0	65	6
SAB 80	135	221	145	56.5	75	6
SAB 100	190	357	220	92.5	90	6
SAB 125	250	558	352	191.0	140	9

\*The specified suction forces are theoretical values at a vacuum of -0.6 bar and with a smooth, dry workpiece surface - they do not include a safety factor

\*\*The specified lateral forces are values measured at a vacuum of -0.6 bar with a dry or oily, smooth, flat workpiece surface. Depending on the workpiece surface and its quality, the actual values may deviate from these values.

\*\*\*The recommended hose diameter refers to a hose length of approx. 2 m



# Bellows Suction Cups SAB HT1 (1.5 Folds)

Suction area ( $\varnothing$ ) from 22 mm to 125 mm



## Design Data Bellows Suction Cups SAB HT1 (1.5 Folds)

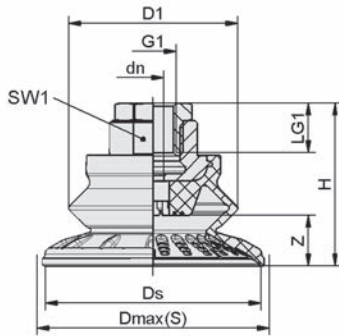

SAB HT1 IG

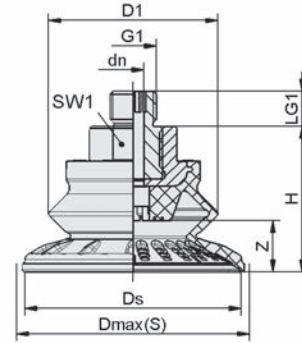

SAB HT1 AG

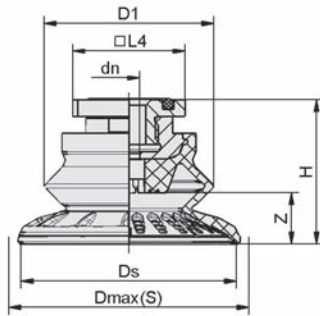

SAB HT1 RA

Type*	D1 [mm]	dn [mm]	Dmax(S) [mm]**	Ds [mm]	G1	H [mm]	LG1 [mm]	L4 [mm]	SW1 [mm]	Z (Stroke) [mm]
SAB 22 HT1-60 G1/4-AG	22	3.5	24	21	G1/4"-M	25.0	10.0	-	16	5.8
SAB 22 HT1-60 G1/4-IG	22	3.5	24	21	G1/4"-F	25.0	12.0	-	16	5.8
SAB 22 HT1-60 G3/8-AG	22	3.5	24	21	G3/8"-M	25.0	10.0	-	16	5.8
SAB 22 HT1-60 G3/8-IG	22	3.5	24	21	G3/8"-F	41.0	9.5	-	22	5.8
SAB 30 HT1-60 G1/4-AG	32	4.0	34	31	G1/4"-M	28.0	10.0	-	17	9.0
SAB 30 HT1-60 G1/4-IG	32	4.0	34	31	G1/4"-F	28.0	12.0	-	17	9.0
SAB 30 HT1-60 G3/8-AG	32	4.0	34	31	G3/8"-M	28.0	10.0	-	17	9.0
SAB 30 HT1-60 G3/8-IG	32	4.0	34	31	G3/8"-F	44.0	9.5	-	22	9.0
SAB 30 HT1-60 RA	32	4.0	34	31	-	31.2	-	31.8	-	9.0
SAB 40 HT1-60 G1/4-AG	32	4.0	45	41	G1/4"-M	28.8	10.0	-	17	10.0
SAB 40 HT1-60 G1/4-IG	32	4.0	45	41	G1/4"-F	28.8	12.0	-	17	10.0
SAB 40 HT1-60 G3/8-AG	32	4.0	45	41	G3/8"-M	28.8	10.0	-	17	10.0
SAB 40 HT1-60 G3/8-IG	32	4.0	45	41	G3/8"-F	44.8	9.5	-	22	10.0
SAB 40 HT1-60 RA	32	4.0	45	41	-	31.2	-	31.8	-	10.0
SAB 50 HT1-60 G1/4-AG	40	6.0	56	51	G1/4"-M	36.9	10.0	-	22	11.5
SAB 50 HT1-60 G1/4-IG	40	6.0	56	51	G1/4"-F	42.0	20.0	-	22	11.5



Schmalz – The Company  
Vacuum Suction Cups  
Special Grippers  
Gripping Systems  
Clamping Systems  
Mounting Elements  
Vacuum Generators  
Valve Technology  
Switches and Monitoring  
Filters and Connections  
Services  
Contact  
Glossary  
Index of Products

# Bellows Suction Cups SAB HT1 (1.5 Folds)

Suction area (Ø) from 22 mm to 125 mm



## Design Data Bellows Suction Cups SAB HT1 (1.5 Folds)

Type*	D1 [mm]	dn [mm]	Dmax(S) [mm]**	Ds [mm]	G1	H [mm]	LG1 [mm]	L4 [mm]	SW1 [mm]	Z (Stroke) [mm]
SAB 50 HT1-60 G3/8-AG	40	6.0	56	51	G3/8"-M	36.9	10.0	-	22	11.5
SAB 50 HT1-60 G3/8-IG	40	6.0	56	51	G3/8"-F	36.9	15.0	-	22	11.5
SAB 50 HT1-60 RA	40	6.0	56	51	-	36.6	-	31.8	-	11.5
SAB 60 HT1-60 G1/4-AG	48	6.0	67	62	G1/4"-M	41.3	10.0	-	22	14.5
SAB 60 HT1-60 G1/4-IG	48	6.0	67	62	G1/4"-F	46.3	20.0	-	22	14.5
SAB 60 HT1-60 G3/8-AG	48	6.0	67	62	G3/8"-M	41.3	10.0	-	22	14.5
SAB 60 HT1-60 G3/8-IG	48	6.0	67	62	G3/8"-F	41.3	15.0	-	22	14.5
SAB 60 HT1-60 RA	48	6.0	67	62	-	41.0	-	31.8	-	14.5
SAB 80 HT1-60 G1/4-AG	64	6.0	89	82	G1/4"-M	49.9	10.0	-	22	22.1
SAB 80 HT1-60 G1/4-IG	64	6.0	89	82	G1/4"-F	54.9	20.0	-	22	22.1
SAB 80 HT1-60 G3/8-AG	64	6.0	89	82	G3/8"-M	49.9	10.0	-	22	22.1
SAB 80 HT1-60 G3/8-IG	64	6.0	89	82	G3/8"-F	49.9	15.0	-	22	22.1
SAB 80 HT1-60 RA	64	6.0	89	82	-	49.6	-	31.8	-	22.1
SAB 100 HT1-60 G1/4-AG	77	6.0	110	101	G1/4"-M	56.6	10.0	-	22	25.8
SAB 100 HT1-60 G1/4-IG	77	6.0	110	101	G1/4"-F	61.8	20.0	-	22	25.8
SAB 100 HT1-60 G3/8-AG	77	6.0	110	101	G3/8"-M	56.6	10.0	-	22	25.8
SAB 100 HT1-60 G3/8-IG	77	6.0	110	101	G3/8"-F	56.6	15.0	-	22	25.8
SAB 100 HT1-60 RA	77	6.0	110	101	-	56.3	-	31.8	-	25.8
SAB 125 HT1-60 G1/4-AG	94	6.0	135	126	G1/4"-M	67.8	10.0	-	22	32.0
SAB 125 HT1-60 G1/4-IG	94	6.0	135	126	G1/4"-F	72.8	20.0	-	22	32.0
SAB 125 HT1-60 G3/8-AG	94	6.0	135	126	G3/8"-M	67.8	10.0	-	22	32.0
SAB 125 HT1-60 G3/8-IG	94	9.0	135	126	G3/8"-F	67.8	15.0	-	22	32.0

\*Acceptable dimensional tolerances for rubber parts concerning to DIN ISO 3302-1 M3

\*\*External dimension of the suction cup when it is pressed against the workpiece by the vacuum

# Bellows Suction Cups SAOB HT1 (Oval, 1.5 Folds)

Suction area (LxW) from 60 x 30 mm to 140 x 70 mm



Bellows Suction Cups SAOB HT1 (Oval, 1.5 Folds)

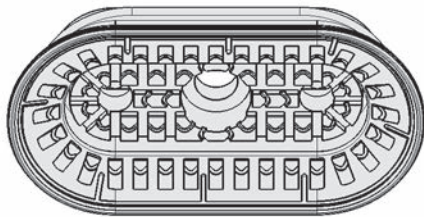

System Design Bellows Suction Cups SAOB HT1 (Oval, 1.5 Folds)



Bellows Suction cups SAOB HT1 being used for handling hollow glass

## Suitability for Industry Specific Applications

### Applications

- Oval bellows suction cup with 1.5 folds for dynamic handling of elongated glass workpieces
- Handling of flat glass and also formed glass pieces
- Use in automated production lines for automotive glass such as windscreens and side windows, even after the bending process at temperatures up to 170° C
- Exact positioning in production processes without displacement
- High lateral forces in use with separation powder on flat glass or on wet glass surfaces

### Design

- Robust, wear-resistant oval bellows suction cup SAOB with 1.5 folds made of HT1, with single sealing lip, special groove and inner support
- Connection element glued to the reinforcing element of the suction cup (very high strength)
- Special structure of the suction surface for high resistance to lateral forces

### Our Highlights...

- Non-marking material HT1
- High temperature resistance
- Large, structured inner support

### Your Benefits...

- Minimal chemical influence on the workpiece surface
- Handling of hot workpieces without modification of the material properties
- Capable of handling high lateral forces, especially in use with separating powder and wet workpieces

# Bellows Suction Cups SAOB HT1 (Oval, 1.5 Folds)

Suction area (LxW) from 60 x 30 mm to 140 x 70 mm



## Designation Code Bellows Suction Cups SAOB HT1 (Oval, 1.5 Folds)

<b>SAOB</b>	-	<b>110x55</b>	-	<b>HT1-60</b>	-	<b>G1/4-AG</b>
<b>1</b>		<b>2</b>		<b>3</b>		<b>4</b>

### 1 - Abbreviated designation

Code	Version
SAOB	1.5 folds, oval

### 2 - Suction area

Code	LxW in mm
60x30...140x70	60x30 to 140x70

### 3 - Material

Code	Material
HT1-60	High temperature material

### 4 - Connection

Code	Connection
G1/4-AG	G1/4-AG (AG = male (M))
G1/4-IG	G1/4-IG (IG = female (F))
G3/8-AG	G3/8-AG
G3/8-IG	G3/8-IG

Suction cup SAOB HT1, available in various diameters, is delivered with connection nipple glued to elastomer part.



## Ordering Data Bellows Suction Cups SAOB HT1 (Oval, 1.5 Folds)

Type	Vacuum connection:			
	G1/4-AG	G1/4-IG	G3/8-AG	G3/8-IG
SAOB 60x30	10.01.06.03156	10.01.06.03175	10.01.06.03201	10.01.06.03202
SAOB 80x40	10.01.06.03203	10.01.06.03176	10.01.06.03204	10.01.06.03205
SAOB 110x55	10.01.06.03206	10.01.06.03178	10.01.06.03207	10.01.06.03208
SAOB 140x70	10.01.06.03209	10.01.06.03177	10.01.06.03210	10.01.06.03211



## Technical Data Bellows Suction Cups SAOB HT1 (Oval, 1.5 Folds)

Type	Suction force [N]*	Pull-off force [N]	Lateral force [N]**	Volume [cm³]	Workpiece radius min. (convex) [mm]	Hose diameter (recom.) d [mm]***
SAOB 60x30	38	70	81	10.5	18	4
SAOB 80x40	65	132	153	21.8	25	6
SAOB 110x55	110	234	300	53.1	50	6
SAOB 140x70	165	352	459	106.0	70	6

\*The specified suction forces are theoretical values at a vacuum of -0.6 bar and with a smooth, dry workpiece surface - they do not include a safety factor

\*\*The specified lateral forces are values measured at a vacuum of -0.6 bar with a dry or oily, smooth, flat workpiece surface. Depending on the workpiece surface and its quality, the actual values may deviate from these values.

\*\*\*The recommended hose diameter refers to a hose length of approx. 2 m



# Bellows Suction Cups SAOB HT1 (Oval, 1.5 Folds)

Suction area (LxW) from 60 x 30 mm to 140 x 70 mm



## Design Data Bellows Suction Cups SAOB HT1 (Oval, 1.5 Folds)

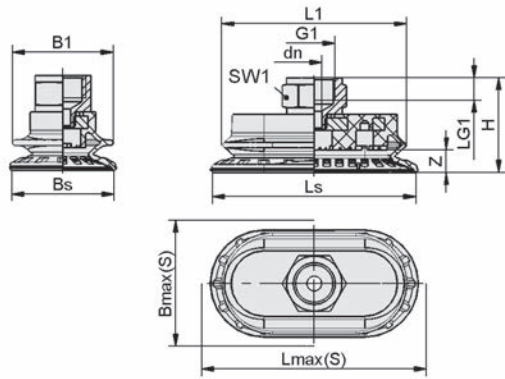

SAOB HT1 IG

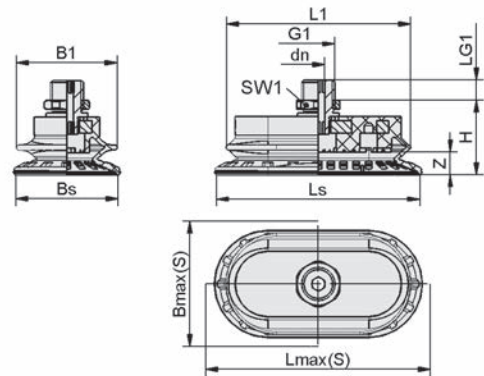

SAOB HT1 AG

Type*	B1 [mm]	Bmax(S) [mm]**	Bs [mm]	dn [mm]	G1	H [mm]	L1 [mm]	LG1 [mm]	Lmax(S) [mm]***	Ls [mm]	SW1 [mm]	Z (Stroke) [mm]
SAOB 60x30 HT1-60 G1/4-AG	31	33	30.6	5.0	G1/4"-M	27.0	55.7	8.0	63.0	61	17	7.0
SAOB 60x30 HT1-60 G1/4-IG	31	33	30.6	5.5	G1/4"-F	34.4	55.7	8.0	63.0	61	17	7.0
SAOB 60x30 HT1-60 G3/8-AG	31	33	30.6	5.2	G3/8"-M	27.5	55.7	7.4	63.0	61	22	7.0
SAOB 60x30 HT1-60 G3/8-IG	31	33	30.6	6.0	G3/8"-F	35.0	55.7	9.0	63.0	61	22	7.0
SAOB 80x40 HT1-60 G1/4-AG	40	43	40.6	5.0	G1/4"-M	29.7	73.3	8.0	83.0	81	17	9.0
SAOB 80x40 HT1-60 G1/4-IG	40	43	40.6	6.0	G1/4"-F	37.2	73.3	8.0	83.0	81	17	9.0
SAOB 80x40 HT1-60 G3/8-AG	40	43	40.6	5.2	G3/8"-M	27.7	73.3	8.0	83.0	81	22	9.0
SAOB 80x40 HT1-60 G3/8-IG	40	43	40.6	6.0	G3/8"-F	37.7	73.3	9.0	83.0	81	22	9.0
SAOB 110x55 HT1-60 G1/4-AG	53	59	55.1	6.0	G1/4"-M	35.5	98.8	8.0	114.0	111	17	12.0
SAOB 110x55 HT1-60 G1/4-IG	53	59	55.1	8.0	G1/4"-F	43.0	98.8	8.0	114.0	111	17	12.0
SAOB 110x55 HT1-60 G3/8-AG	53	59	55.1	6.1	G3/8"-M	33.5	98.8	8.0	114.0	111	22	12.0
SAOB 110x55 HT1-60 G3/8-IG	53	59	55.1	8.0	G3/8"-F	43.5	98.8	9.0	114.0	111	22	12.0
SAOB 140x70 HT1-60 G1/4-AG	67	75	70.1	6.0	G1/4"-M	39.5	126.0	8.0	146.0	142	17	16.5
SAOB 140x70 HT1-60 G1/4-IG	67	75	70.1	8.0	G1/4"-F	47.0	126.0	8.0	146.0	142	17	16.5
SAOB 140x70 HT1-60 G3/8-AG	67	75	70.1	6.0	G3/8"-M	37.5	126.0	10.0	146.0	142	19	16.5
SAOB 140x70 HT1-60 G3/8-IG	67	75	70.1	8.0	G3/8"-F	47.5	126.0	9.0	146.0	142	22	16.5

\*Acceptable dimensional tolerances for rubber parts concerning to DIN ISO 3302-1 M3

\*\*External dimension of the suction cup when it is pressed against the workpiece by the vacuum

\*\*\*External dimension of the suction cup when it is pressed against the workpiece by the vacuum

Schmalz – The Company  
 Vacuum Suction Cups  
 Special Grippers  
 Gripping Systems  
 Clamping Systems  
 Mounting Elements  
 Vacuum Generators  
 Valve Technology  
 Switches and Monitoring  
 Filters and Connections  
 Services  
 Contact  
 Glossary  
 Index of Products



# Flat Suction Cups SAF HT2

Suction area (Ø) from 30 mm to 60 mm



## Suitability for Industry Specific Applications

### Applications

- Round, flat suction cups for dynamic handling of hot metal sheets up to 250° C (short cycle times)
- Unloading of parts after forming
- Handling of thin aluminum sheets without deformation or deep drawing
- For use e.g. in feeder systems for press lines in the automotive industry



Flat Suction Cups SAF HT2

### Design

- Robust and wear-resistant suction cup SAF made of HT2 with special inner support
- Suction cup SAF vulcanized to the connection nipple (very high strength)

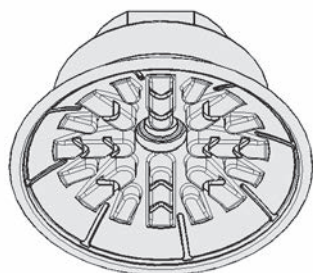

System Design Flat Suction Cups SAF HT2



Flat suction cup SAF HT2 for handling formed sheet metal parts

### Our Highlights...

- Silicone-free material HT2
- Large structured inner support
- Soft and flexible sealing lip

### Your Benefits...

- Absence of PWIS (paint wetting impairment substances), temperature resistance up to 250° C long term
- No deep drawing of the workpiece; capable of handling high lateral forces
- Good sealing, even on slightly curved surfaces





# Flat Suction Cups SAF HT2

Suction area (Ø) from 30 mm to 60 mm



## Designation Code Flat Suction Cups SAF HT2

SAF	-	60	-	HT2-65	-	G3/8-IG
1		2		3		4

### 1 – Abbreviated designation

Code	Version
SAF	Flat

### 2 – Suction area

Code	Diameter in mm
30...60	ø 30 to 60

### 3 – Material

Code	Material
HT2-65	High temperature material

### 4 – Connection

Code	Connection
G1/4-AG	G1/4-AG (AG = male (M))
G1/4-IG	G1/4-IG (IG = female (F))
G3/8-IG	G3/8-IG

Suction cup SAF HT2, available in various diameters, is delivered with connection nipple vulcanized to elastomer part.



## Ordering Data Flat Suction Cups SAF HT2

Type	Vacuum connection:		
	G1/4-AG	G1/4-IG	G3/8-IG
SAF 30	10.01.01.12349	10.01.01.12348	10.01.01.12350
SAF 40	10.01.01.12353	10.01.01.12352	10.01.01.12354
SAF 50	10.01.01.12357	10.01.01.12356	10.01.01.12358
SAF 60	10.01.01.12361	10.01.01.12360	10.01.01.12362



## Technical Data Flat Suction Cups SAF HT2

Type	Suction force [N]*	Lateral force [N]**	Volume [cm <sup>3</sup> ]	Workpiece radius min. (convex) [mm]	Hose diameter (recom.) d [mm]***
SAF 30	38	29	1.7	40	4
SAF 40	69	51	3.8	50	4
SAF 50	100	78	7.0	65	4
SAF 60	150	102	13.0	75	6

\*The specified suction forces are theoretical values at a vacuum of -0.6 bar and with a smooth, dry workpiece surface - they do not include a safety factor

\*\*The specified lateral forces are values measured at a vacuum of -0.6 bar with a dry or oily, smooth, flat workpiece surface. Depending on the workpiece surface and its quality, the actual values may deviate from these values.

\*\*\*The recommended hose diameter refers to a hose length of approx. 2 m



# Flat Suction Cups SAF HT2

Suction area (Ø) from 30 mm to 60 mm



## Design Data Flat Suction Cups SAF HT2

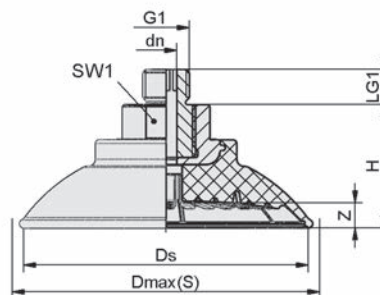
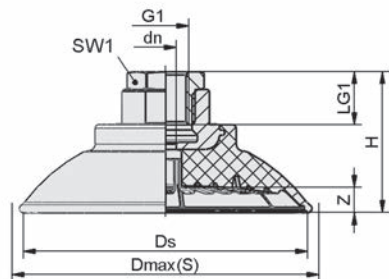

SAF HT2 IG

SAF HT2 AG

Type*	Dmax(S) [mm]**	dn [mm]	Ds [mm]	G1	H [mm]	LG1 [mm]	SW1 [mm]	Z (Stroke) [mm]
SAF 30 HT2-65 G1/4-AG	34	4	31	G1/4"-M	20	10	17	3
SAF 30 HT2-65 G1/4-IG	34	4	31	G1/4"-F	20	12	17	3
SAF 30 HT2-65 G3/8-IG	34	4	31	G3/8"-F	36	9	22	3
SAF 40 HT2-65 G1/4-AG	46	4	41	G1/4"-M	22	10	17	4
SAF 40 HT2-65 G1/4-IG	46	4	41	G1/4"-F	22	12	17	4
SAF 40 HT2-65 G3/8-IG	46	4	41	G3/8"-F	38	9	22	4
SAF 50 HT2-65 G1/4-AG	56	6	50	G1/4"-M	28	10	22	5
SAF 50 HT2-65 G1/4-IG	56	6	50	G1/4"-F	33	15	22	5
SAF 50 HT2-65 G3/8-IG	56	6	50	G3/8"-F	28	15	22	5
SAF 60 HT2-65 G1/4-AG	67	6	61	G1/4"-M	31	10	22	6
SAF 60 HT2-65 G1/4-IG	67	6	61	G1/4"-F	36	15	22	6
SAF 60 HT2-65 G3/8-IG	67	6	61	G3/8"-F	31	15	22	6

\*Acceptable dimensional tolerances for rubber parts concerning to DIN ISO 3302-1 M3

\*\*External dimension of the suction cup when it is pressed against the workpiece by the vacuum



Schmalz - The Company  
 Vacuum Suction Cups  
 Special Grippers  
 Gripping Systems  
 Clamping Systems  
 Mounting Elements  
 Vacuum Generators  
 Valve Technology  
 Switches and Monitoring  
 Filters and Connections  
 Services  
 Contact  
 Glossary  
 Index of Products

# Bellows Suction Cups SAB HT2 (1.5 Folds)

Suction area (Ø) from 22 mm to 80 mm

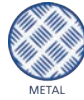

## Suitability for Industry Specific Applications

### Applications

- Round bellows suction cup with 1.5 folds for dynamic handling of hot metal sheets up to 250° C
- Handling of pre-shaped metal sheet parts, bellows shape permits optimum adaptation
- Unloading of parts after forming
- Handling of thin aluminum sheets without deformation or deep drawing
- For use e.g. in feeder systems for press lines in the automotive industry



Bellows Suction Cups SAB HT2 (1.5 Folds)

### Design

- Robust and wear resistant bellows suction cup SAB made of HT2 with 1.5 folds and special inner support
- Suction cup SAB vulcanized to the connection nipple (very high strength)

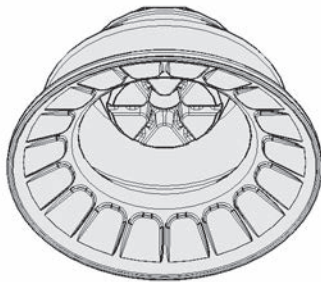

System Design Bellows Suction Cups SAB HT2 (1.5 Folds)



Bellows suction cups SAB HT2 for handling formed sheet metal parts

### Our Highlights...

- Silicone-free special material HT2
- Large structured inner support
- Soft and flexible sealing lip
- 1.5 folds

### Your Benefits...

- Absence of PWIS (paint wetting impairment substances), temperature resistance up to 250° C long term
- No deep-drawing of the workpiece; capable of handling high lateral forces
- Good sealing, even on slightly curved surfaces
- Optimum adaptation and sealing to curved workpieces, very good damping



# Bellows Suction Cups SAB HT2 (1.5 Folds)

Suction area (Ø) from 22 mm to 80 mm

## Designation Code Bellows Suction Cups SAB HT2 (1.5 Folds)

<b>SAB</b>	-	<b>30</b>	-	<b>HT2-65</b>	-	<b>G1/4-AG</b>
<b>1</b>		<b>2</b>		<b>3</b>		<b>4</b>

### 1 - Abbreviated designation

Code	Version
SAB	1.5 folds

### 2 - Suction area

Code	Diameter in mm
22...80	ø 22 to 80

### 3 - Material

Code	Material
HT2-65	High temperature material

### 4 - Connection

Code	Connection
G1/4-AG	G1/4-AG (AG = male (M))
G1/4-IG	G1/4-IG (IG = female (F))
G3/8-IG	G3/8-IG

Suction cup SAB HT2, available in various diameters, is delivered with connection nipple vulcanized to elastomer part.

## Ordering Data Bellows Suction Cups SAB HT2 (1.5 Folds)

Type	Vacuum connection:		
	G1/4-AG	G1/4-IG	G3/8-IG
SAB 22	10.01.06.02420	10.01.06.02419	10.01.06.02421
SAB 30	10.01.06.02424	10.01.06.02423	10.01.06.02425
SAB 40	10.01.06.02428	10.01.06.02427	10.01.06.02429
SAB 50	10.01.06.03452	10.01.06.03451	10.01.06.03401
SAB 60	10.01.06.03450	10.01.06.03449	10.01.06.03354
SAB 80	10.01.06.03357	10.01.06.03356	10.01.06.03318

## Technical Data Bellows Suction Cups SAB HT2 (1.5 Folds)

Type	Suction force [N]*	Pull-off force [N]	Lateral force [N]**	Volume [cm³]	Workpiece radius min. (convex) [mm]	Hose diameter (recom.) d [mm]***
SAB 22	16	24	17	1.5	20	4
SAB 30	22	33	29	5.6	40	4
SAB 40	38	59	34	7.0	40	4
SAB 50	53	91	102	18.9	25	6
SAB 60	82	136	126	32.0	30	6
SAB 80	135	238	217	75.4	40	6

\*The specified suction forces are theoretical values at a vacuum of -0.6 bar and with a smooth, dry workpiece surface - they do not include a safety factor

\*\*The specified lateral forces are values measured at a vacuum of -0.6 bar with a dry or oily, smooth, flat workpiece surface. Depending on the workpiece surface and its quality, the actual values may deviate from these values.

\*\*\*The recommended hose diameter refers to a hose length of approx. 2 m

Schmalz - The Company  
 Vacuum Suction Cups  
 Special Grippers  
 Gripping Systems  
 Clamping Systems  
 Mounting Elements  
 Vacuum Generators  
 Valve Technology  
 Switches and Monitoring  
 Filters and Connections  
 Services  
 Contact  
 Glossary  
 Index of Products

# Bellows Suction Cups SAB HT2 (1.5 Folds)

Suction area (Ø) from 22 mm to 80 mm



## Design Data Bellows Suction Cups SAB HT2 (1.5 Folds)

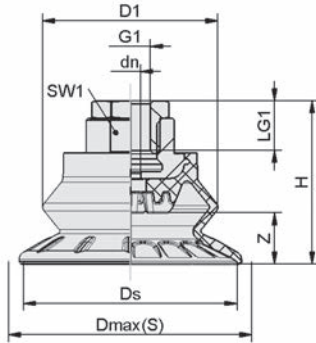

SAB HT2 IG

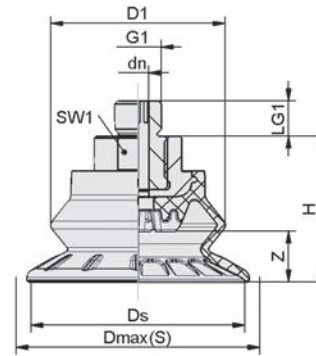

SAB HT2 AG

Type*	dn [mm]	D1 [mm]	Dmax(S) [mm]**	Ds [mm]	G1	H [mm]	LG1 [mm]	SW1 [mm]	Z (Stroke) [mm]
SAB 22 HT2-65 G1/4-AG	3.5	22	24	21	G1/4"-M	25.0	10.0	16	5.8
SAB 22 HT2-65 G1/4-IG	3.5	22	24	21	G1/4"-F	25.0	12.0	16	5.8
SAB 22 HT2-65 G3/8-IG	3.5	22	24	21	G3/8"-F	41.0	9.5	22	5.8
SAB 30 HT2-65 G1/4-AG	4.0	32	34	31	G1/4"-M	28.0	10.0	17	9.0
SAB 30 HT2-65 G1/4-IG	4.0	32	34	31	G1/4"-F	28.0	12.0	17	9.0
SAB 30 HT2-65 G3/8-IG	4.0	32	34	31	G3/8"-F	44.0	9.5	22	9.0
SAB 40 HT2-65 G1/4-AG	4.0	32	45	41	G1/4"-M	29.0	10.0	17	10.0
SAB 40 HT2-65 G1/4-IG	4.0	32	45	41	G1/4"-F	29.0	12.0	17	10.0
SAB 40 HT2-65 G3/8-IG	4.0	32	45	41	G3/8"-F	44.0	9.5	22	10.0
SAB 50 HT2-65 G1/4-AG	6.0	43	56	51	G1/4"-M	36.9	10.0	22	11.5
SAB 50 HT2-65 G1/4-IG	6.0	43	56	51	G1/4"-F	41.9	20.0	22	11.5
SAB 50 HT2-65 G3/8-IG	6.0	43	56	51	G3/8"-F	36.9	15.0	22	11.5
SAB 60 HT2-65 G1/4-AG	6.0	50	67	62	G1/4"-M	41.3	10.0	22	14.5
SAB 60 HT2-65 G1/4-IG	6.0	50	67	62	G1/4"-F	46.3	20.0	22	14.5
SAB 60 HT2-65 G3/8-IG	6.0	50	67	62	G3/8"-F	41.3	15.0	22	14.5
SAB 80 HT2-65 G1/4-AG	6.0	65	88	82	G1/4"-M	49.8	10.0	22	22.0
SAB 80 HT2-65 G1/4-IG	6.0	65	88	82	G1/4"-F	54.8	15.0	22	22.0
SAB 80 HT2-65 G3/8-IG	6.0	65	88	82	G3/8"-F	49.8	15.0	22	22.0

\*Acceptable dimensional tolerances for rubber parts concerning to DIN ISO 3302-1 M3

\*\*External dimension of the suction cup when it is pressed against the workpiece by the vacuum

# Flat Suction Cups SAOF HT2 (Oval)

Suction area (LxW) from 60 x 23 mm to 100 x 50 mm



## Suitability for Industry Specific Applications

### Applications

- Oval flat suction cup for dynamic handling of hot metal sheets up to 250° C
- Unloading e.g. of elongated workpieces after forming
- Handling of thin aluminum sheets without deformation or deep drawing
- For use e.g. in feeder systems for press lines in the automotive industry



Flat Suction Cups SAOF HT2 (Oval)

### Design

- Robust, wear-resistant oval flat suction cup SAOF made of HT2 with single sealing lip and inner support
- Connection nipple glued to the reinforcing element of the suction cup (very high strength and temperature resistance)

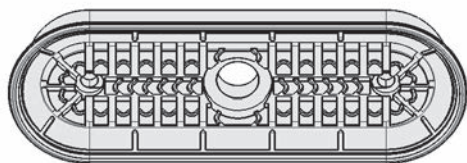

System Design Flat Suction Cups SAOF HT2 (Oval)



Flat suction cups SAOF HT2 for handling formed sheet metal parts

### Our Highlights...

- Silicone-free special material HT2
- Large, structured inner support
- Soft and flexible sealing lip

### Your Benefits...

- Absence of PWIS (paint wetting impairment substances), temperature resistance up to 250° C long term
- No deep-drawing of the workpiece; capable of handling high lateral forces
- Good sealing, even on slightly curved surfaces

Schmalz – The Company

Vacuum Suction Cups

Special Grippers

Gripping Systems

Clamping Systems

Mounting Elements

Vacuum Generators

Valve Technology

Switches and Monitoring

Filters and Connections

Services

Contact

Glossary

Index of Products

# Flat Suction Cups SAOF HT2 (Oval)

Suction area (LxW) from 60 x 23 mm to 100 x 50 mm



## Designation Code Flat Suction Cups SAOF HT2 (Oval)

<b>SAOF</b>	-	<b>80x40</b>	-	<b>HT2-65</b>	-	<b>G1/4-IG</b>
1		2		3		4

### 1 – Abbreviated designation

Code	Version
SAOF	Flat, oval

### 2 – Suction area

Code	LxW in mm
60x23...100x50	60x23 to 100x50

### 3 – Material

Code	Material
HT2-65	High temperature material

### 4 – Connection

Code	Connection
G1/4-AG	G1/4-AG (AG = male (M))
G1/4-IG	G1/4-IG (IG = female (F))
G3/8-IG	G3/8-IG

Suction cup SAOF HT2, available in various dimensions, is delivered with connection nipple glued to elastomer part.



## Ordering Data Flat Suction Cups SAOF HT2 (Oval)

Type	Vacuum connection:			
		G1/4-AG	G1/4-IG	G3/8-IG
SAOF 60x23	10.01.05.00743	10.01.05.00742	10.01.05.00741	
SAOF 80x40	10.01.05.00751	10.01.05.00750	10.01.05.00749	
SAOF 90x30	10.01.05.00747	10.01.05.00746	10.01.05.00745	
SAOF 100x50	10.01.05.00755	10.01.05.00754	10.01.05.00753	



## Technical Data Flat Suction Cups SAOF HT2 (Oval)

Type		Suction force [N]*	Lateral force [N]**	Volume [cm <sup>3</sup> ]	Workpiece radius min. (convex) [mm]	Hose diameter (recom.) d [mm]***
SAOF 60x23		57	36	3.0	20	4
SAOF 80x40		140	108	10.7	50	4
SAOF 90x30		122	94	7.0	40	4
SAOF 100x50		217	177	20.0	75	6

\*The specified suction forces are theoretical values at a vacuum of -0.6 bar and with a smooth, dry workpiece surface - they do not include a safety factor

\*\*The specified lateral forces are values measured at a vacuum of -0.6 bar with a dry or oily, smooth, flat workpiece surface. Depending on the workpiece surface and its quality, the actual values may deviate from these values.

\*\*\*The recommended hose diameter refers to a hose length of approx. 2 m

# Flat Suction Cups SAOF HT2 (Oval)

Suction area (LxW) from 60 x 23 mm to 100 x 50 mm

## Design Data Flat Suction Cups SAOF HT2 (Oval)

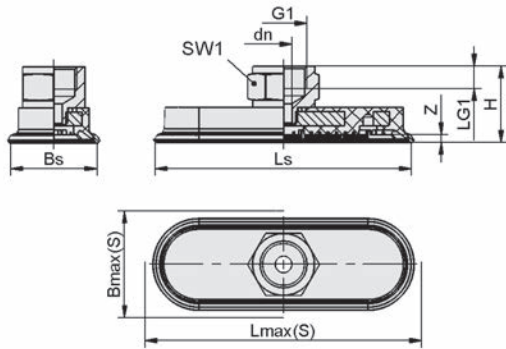

SAOF HT2 IG

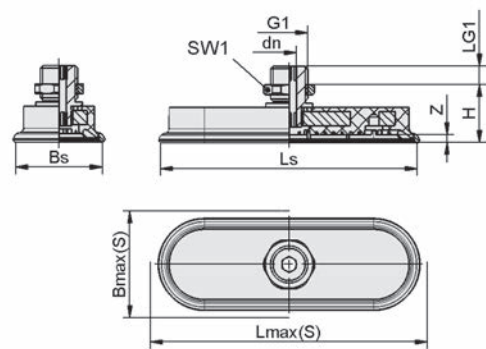

SAOF HT2 AG

Type*	Bmax(S) [mm]**	Bs [mm]	dn [mm]	G1	H [mm]	LG1 [mm]	Lmax(S) [mm]***	Ls [mm]	SW1 [mm]	Z (Stroke) [mm]
SAOF 60x23 HT2-65 G1/4-AG	25	22	5.0	G1/4"-M	18.0	8	64	61	17	3
SAOF 60x23 HT2-65 G1/4-IG	25	22	6.0	G1/4"-F	26.0	8	64	61	17	3
SAOF 60x23 HT2-65 G3/8-IG	25	22	6.0	G3/8"-F	26.0	8	64	61	22	3
SAOF 80x40 HT2-65 G1/4-AG	43	39	5.0	G1/4"-M	20.0	8	85	81	17	4
SAOF 80x40 HT2-65 G1/4-IG	43	39	6.0	G1/4"-F	28.0	8	85	81	17	4
SAOF 80x40 HT2-65 G3/8-IG	43	39	6.0	G3/8"-F	28.0	9	85	81	22	4
SAOF 90x30 HT2-65 G1/4-AG	34	31	5.0	G1/4"-M	19.0	8	94	91	17	3
SAOF 90x30 HT2-65 G1/4-IG	34	31	6.0	G1/4"-F	26.0	8	94	91	17	3
SAOF 90x30 HT2-65 G3/8-IG	34	31	6.0	G3/8"-F	27.0	9	94	91	22	3
SAOF 100x50 HT2-65 G1/4-AG	54	49	6.0	G1/4"-M	22.0	8	106	102	17	5
SAOF 100x50 HT2-65 G1/4-IG	54	49	8.0	G1/4"-F	30.0	8	106	102	17	5
SAOF 100x50 HT2-65 G3/8-IG	54	49	8.0	G3/8"-F	30.5	9	106	102	22	5

\*Acceptable dimensional tolerances for rubber parts concerning to DIN ISO 3302-1 M3

\*\*External dimension of the suction cup when it is pressed against the workpiece by the vacuum

\*\*\*External dimension of the suction cup when it is pressed against the workpiece by the vacuum

Schmalz - The Company  
 Vacuum Suction Cups  
 Special Grippers  
 Gripping Systems  
 Clamping Systems  
 Mounting Elements  
 Vacuum Generators  
 Valve Technology  
 Switches and Monitoring  
 Filters and Connections  
 Services  
 Contact  
 Glossary  
 Index of Products



# Bellows Suction Cups SAOB HT2 (Oval, 1.5 Folds)

Suction area (LxW) 60 x 30 mm and 80 x 40 mm

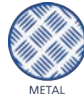

Bellows Suction Cups SAOB HT2 (Oval, 1.5 Folds)

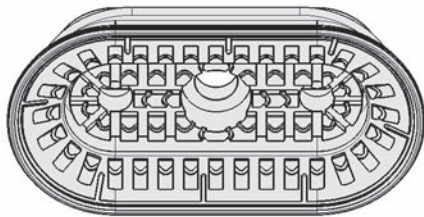

System Design Bellows Suction Cups SAOB HT2 (Oval, 1.5 Folds)

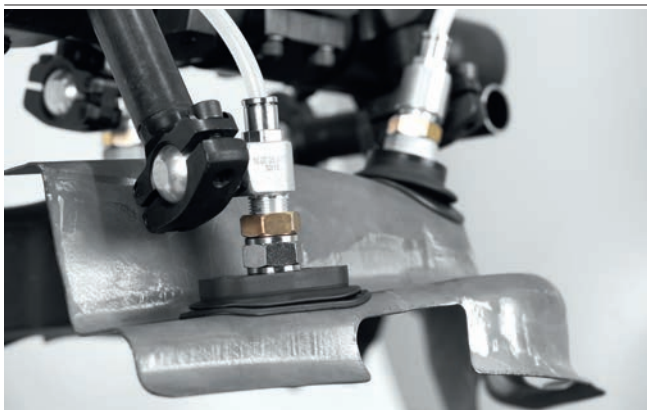

Bellows suction cups SAOB HT2 for handling formed sheet metal parts

## Suitability for Industry Specific Applications

### Applications

- Oval bellows suction cup with 1.5 folds for most dynamic handling of hot metal sheets up to 250° C
- Unloading e.g. of elongated workpieces after forming, e.g. reinforced ribs and plates
- Handling of formed sheet metal parts; fold structure allows optimal adjustment
- Handling of thin aluminum sheets without deformation or deep drawing
- For use e.g. in feeder systems for press lines in the automotive industry

### Design

- Robust, wear-resistant oval bellows suction cup SAOB with 1.5 folds made of HT2, single sealing lip and inner support
- Connection nipple glued to the reinforcing element of the suction cup (very high strength and temperature resistance)

### Our Highlights...

- Silicone-free special material HT2
- Large, structured inner support
- Soft and flexible sealing lip
- 1.5 folds

### Your Benefits...

- Absence of PWIS (paint wetting impairment substances), up to 250° C temperature resistance long term
- No deep-drawing of the workpiece; capable of handling high lateral forces
- Good sealing of even slightly curved surfaces
- Optimum adaptation to curved workpieces, very good damping



# Bellows Suction Cups SAOB HT2 (Oval, 1.5 Folds)

Suction area (LxW) 60 x 30 mm and 80 x 40 mm

## Designation Code Bellows Suction Cups SAOB HT2 (Oval, 1.5 Folds)

<b>SAOB</b>	-	<b>60x30</b>	-	<b>HT2-65</b>	-	<b>G3/8-IG</b>
<b>1</b>		<b>2</b>		<b>3</b>		<b>4</b>

### 1 - Abbreviated designation

Code	Version
SAOB	1.5 folds, oval

### 2 - Suction area

Code	LxW in mm
60x30...80x40	60x30 and 80x40

### 3 - Material

Code	Material
HT2-65	High temperature material

### 4 - Connection

Code	Connection
G1/4-AG	G1/4-AG (AG = male (M))
G1/4-IG	G1/4-IG (IG = female (F))
G3/8-IG	G3/8-IG

Suction cup SAOB HT2, available in various dimensions, is delivered with connection nipple glued to elastomer part.

## Ordering Data Bellows Suction Cups SAOB HT2 (Oval, 1.5 Folds)

Type	Vacuum connection:		
	G1/4-AG	G1/4-IG	G3/8-IG
SAOB 60x30	10.01.06.02443	10.01.06.02442	10.01.06.02441
SAOB 80x40	10.01.06.02447	10.01.06.02446	10.01.06.02445

## Technical Data Bellows Suction Cups SAOB HT2 (Oval, 1.5 Folds)

Type	Suction force [N]*	Pull-off force [N]	Lateral force [N]**	Volume [cm³]	Workpiece radius min. (convex) [mm]	Hose diameter (recom.) d [mm]***
SAOB 60x30	38	55	56	9.6	30	4
SAOB 80x40	65	100	98	20.6	40	6

\*The specified suction forces are theoretical values at a vacuum of -0.6 bar and with a smooth, dry workpiece surface - they do not include a safety factor

\*\*The specified lateral forces are values measured at a vacuum of -0.6 bar with a dry or oily, smooth, flat workpiece surface. Depending on the workpiece surface and its quality, the actual values may deviate from these values.

\*\*\*The recommended hose diameter refers to a hose length of approx. 2 m

# Bellows Suction Cups SAOB HT2 (Oval, 1.5 Folds)

Suction area (LxW) 60 x 30 mm and 80 x 40 mm



## Design Data Bellows Suction Cups SAOB HT2 (Oval, 1.5 Folds)

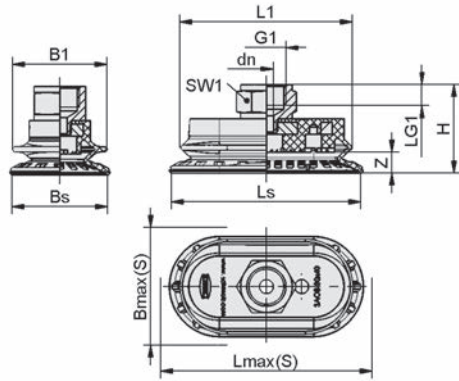

SAOB HT2 IG

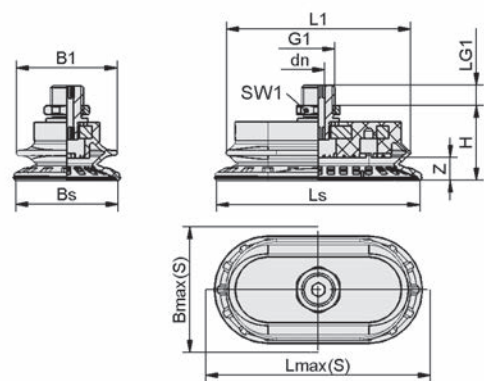

SAOB HT2 AG

Type*	B1 [mm]	Bmax(S) [mm]	Bs [mm]	dn [mm]	G1	H [mm]	L1 [mm]	LG1 [mm]	Lmax(S) [mm]**	Ls [mm]	SW1 [mm]	Z (Stroke) [mm]
SAOB 60x30 HT2-65 G1/4-AG	31	33	30.6	5	G1/4"-M	27.0	56	8	63	61	17	7
SAOB 60x30 HT2-65 G1/4-IG	31	33	30.6	6	G1/4"-F	34.4	56	8	63	61	17	7
SAOB 60x30 HT2-65 G3/8-IG	31	33	30.6	6	G3/8"-F	35.0	56	9	63	61	22	7
SAOB 80x40 HT2-65 G1/4-AG	40	43	40.6	5	G1/4"-M	29.7	74	8	83	81	17	9
SAOB 80x40 HT2-65 G1/4-IG	40	43	40.6	6	G1/4"-F	37.2	74	8	83	81	17	9
SAOB 80x40 HT2-65 G3/8-IG	40	43	40.6	6	G3/8"-F	37.7	74	9	83	81	22	9

\*Acceptable dimensional tolerances for rubber parts concerning to DIN ISO 3302-1 M3

\*\*External dimension of the suction cup when it is pressed against the workpiece by the vacuum

# Suction Plates for High-Temperature SPL-HT FPM-F

Suction area (Ø) 90 mm to 190 mm

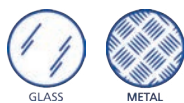

## Suitability for Industry Specific Applications

### Applications

- Round suction plate for handling of very hot workpieces
- Removing of hot cathode ray tubes from molds
- Handling of hot glass



Suction Plates for High-Temperature SPL-HT FPM-F

### Design

- Robust and wear-resistant suction plate SPL-HT FPM-F with single sealing lip, consisting of suction plate SPL and large-area metal mounting
- Suction plate screwed to mounting

### Our Highlights...

- Special materials fluorcaotchuc FPM-F with felt coating
- Suction plate screwed to mounting
- Large-area metal mounting for the suction plate

### Your Benefits...

- Resistance to very high temperatures (up to 400° C for short periods) and little marking of the workpieces
- Suction plate can be replaced separately when worn
- Good heat dissipation, short cooling times



## Designation Code Suction Plates for High-Temperature SPL-HT FPM-F

<b>SPL-HT</b>	–	<b>90</b>	–	<b>FPM-F-65</b>	–	<b>G1/4-AG</b>
<b>1</b>		<b>2</b>		<b>3</b>		<b>4</b>

#### 1 – Abbreviated designation

Code	Version
SPL-HT	Flat

#### 2 – Suction area

Code	Diameter in mm
90...190	ø 90 to 190

#### 3 – Material

Code	Material
FPM-F-65	Fluorcaotchuc

#### 4 – Connection

Code	Connection
G1/4-AG	G1/4-AG (AG = male (M))
G1/2-AG	G1/2-AG

Suction plate SPL-HT FPM-F (elastomer part + mounting) is delivered assembled. The product consists of:

- Suction plate of type SPL-HT FPM-F – available in various diameters
- Mounting – available with various threads

Available spare parts: suction plate SPL-HT FPM-F



Schmalz – The Company  
 Vacuum Suction Cups  
 Special Grippers  
 Gripping Systems  
 Clamping Systems  
 Mounting Elements  
 Vacuum Generators  
 Valve Technology  
 Switches and Monitoring  
 Filters and Connections  
 Services  
 Contact  
 Glossary  
 Index of Products

# Suction Plates for High-Temperature SPL-HT FPM-F

Suction area (Ø) 90 mm to 190 mm



## Ordering Data Suction Plates for High-Temperature SPL-HT FPM-F

Type*	Part no.
SPL-HT 90 FPM-F-65 G1/4-AG	10.01.01.00551
SPL-HT 120 FPM-F-65 G1/4-AG	10.01.01.13438
SPL-HT 190 FPM-F-65 G1/2-AG	10.01.01.00832

\*Additional material specifications at beginning of the section "Vacuum Suction Cups"



## Ordering Data Spare Parts Suction Plates for High-Temperature SPL-HT FPM-F

Type*	Spare Parts	Part no.
SPL-HT 90 FPM-F-65 G1/4-AG	Suction plate (round)	SPL-HT 90 FPM-F-65 10.01.01.00553
SPL-HT 120 FPM-F-65 G1/4-AG	Suction plate (round)	SPL-HT 120 FPM-F-65 10.01.01.13435
SPL-HT 190 FPM-F-65 G1/2-AG	Suction plate (round)	SPL-HT 190 FPM-F-65 10.01.01.00834

\*Additional material specifications at beginning of the section "Vacuum Suction Cups"



## Technical Data Suction Plates for High-Temperature SPL-HT FPM-F

Type	Suction force [N]*	Volume [cm³]	Workpiece radius min. (convex) [mm]	Weight [g]
SPL-HT 90 FPM-F-65 G1/4-AG	230	92	250	225
SPL-HT 120 FPM-F-65 G1/4-AG	675	208	300	295
SPL-HT 190 FPM-F-65 G1/2-AG	1,050	165	350	1,420

\*The specified suction forces are theoretical values at a vacuum of -0.6 bar and with a smooth, dry workpiece surface - they do not include a safety factor



## Design Data Suction Plates for High-Temperature SPL-HT FPM-F

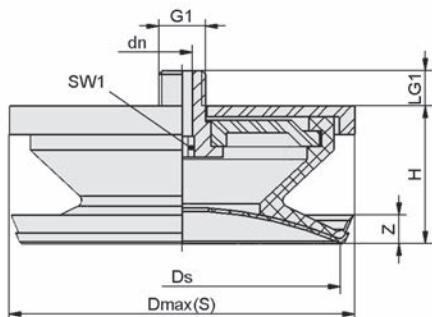

SPL-HT 90, 120 FPM-F

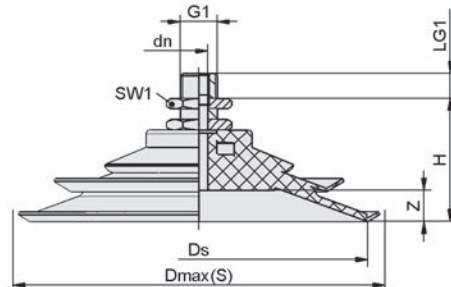

SPL-HT 190 FPM-F



# Suction Plates for High-Temperature SPL-HT FPM-F

Suction area (Ø) 90 mm to 190 mm



## Design Data Suction Plates for High-Temperature SPL-HT FPM-F

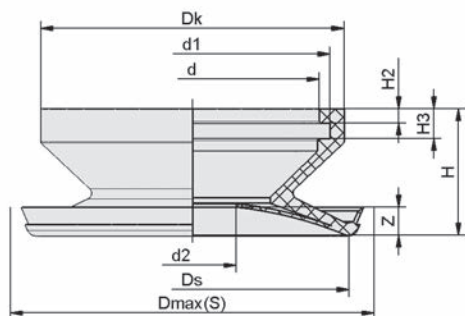

SPL-HT 90, 120 FPM-F

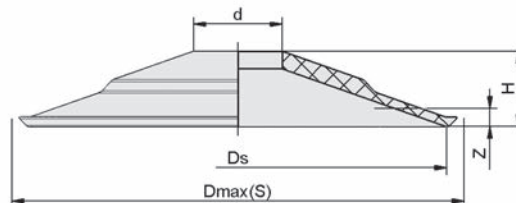

SPL-HT 190 FPM-F

Type*	Dmax(S) [mm]**	dn [mm]	Ds [mm]	G1	H [mm]	LG1 [mm]	SW1 [mm]	Z (Stroke) [mm]
SPL-HT 90 FPM-F-65 G1/4-AG	98	6	90	G1/4"-M	39.0	11	6	16.5
SPL-HT 120 FPM-F-65 G1/4-AG	130	6	120	G1/4"-M	46.0	11	8	25.0
SPL-HT 190 FPM-F-65 G1/2-AG	209	10	190	G1/2"-M	66.0	18	32	8.0

\*Acceptable dimensional tolerances for rubber parts concerning to DIN ISO 3302-1 M3

\*\*External dimension of the suction cup when it is pressed against the workpiece by the vacuum

Type*	d [mm]	d1 [mm]	d2 [mm]	Dk [mm]	Dmax(S) [mm]**	Ds [mm]	H [mm]	H2 [mm]	H3 [mm]	Z (Stroke) [mm]
SPL-HT 90	72	78	15	86	98	90	36	4	9.5	16.5
SPL-HT 120	88	96	15	105	130	120	43	5	10.0	25.0
SPL-HT 190	40	-	-	-	209	190	17	-	-	8.0

\*Acceptable dimensional tolerances for rubber parts concerning to DIN ISO 3302-1 M3

\*\*External dimension of the suction cup when it is pressed against the workpiece by the vacuum



# Suction Plates for High-Temperature SPL-HT

Suction area (Ø) from 35 mm to 140 mm

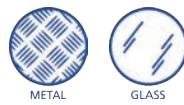

## Suitability for Industry Specific Applications



Suction Plates for High-Temperature SPL-HT

### Design

- Robust stainless-steel body
- Seal clamped into the body and quickly replaceable
- Seal made of special textile material for handling hot workpieces

### Applications

- Round suction plate for handling of workpieces with smooth surfaces
- Usage in manufacturing of float glass or in tempering processes in the glass industry
- Hot forming in the metal industry

### Our Highlights...

- Stainless-steel body; seal made of special textile materials
- Withstanding temperatures of up to 600° C
- Seal quickly and easily replaceable

### Your Benefits...

- Very high temperature resistance (even for long periods)
- Safe and gentle gripping of hot workpieces with vacuum
- Seal can be replaced separately when worn or damaged



## Designation Code Suction Plates for High-Temperature SPL-HT

<b>SPL-HT</b>	-	<b>90</b>	-	<b>ST</b>	-	<b>G1/4-IG</b>
<b>1</b>		<b>2</b>		<b>3</b>		<b>4</b>

#### 1 – Abbreviated designation

Code	Version
SPL-HT	Flat

#### 2 – Suction area

Code	Diameter in mm
35...140	ø 35 to 140

#### 3 – Material

Code	Material
ST	Woven silicate material

#### 4 – Connection

Code	Connection
G1/8-IG	G1/8-IG (IG = female (F))
G1/4-IG	G1/4-IG
G3/8-IG	G3/8-IG

Suction plate SPL-HT (sealing ring + mounting) is delivered assembled. The assembly consists of:

- Sealing ring of type DR-SPL-HT – available in various diameters
- Stainless-steel mounting – available with various threads

Available spare parts: sealing ring DR-SPL-HT

Schmalz – The Company  
Vacuum Suction Cups  
Special Grippers  
Gripping Systems  
Clamping Systems  
Mounting Elements  
Vacuum Generators  
Valve Technology  
Switches and Monitoring  
Filters and Connections  
Services  
Contact  
Glossary  
Index of Products



# Suction Plates for High-Temperature SPL-HT

Suction area (Ø) from 35 mm to 140 mm

Schmalz – The Company  
Vacuum Suction Cups  
Special Grippers  
Gripping Systems  
Clamping Systems  
Mounting Elements  
Vacuum Generators  
Valve Technology  
Switches and Monitoring  
Filters and Connections  
Services  
Contact  
Glossary  
Index of Products

## Ordering Data Suction Plates for High-Temperature SPL-HT

Type	Part no.
SPL-HT 35 ST G1/8-IG	10.01.23.00023
SPL-HT 60 ST G1/4-IG	10.01.23.00006
SPL-HT 90 ST G1/4-IG	10.01.23.00007
SPL-HT 140 ST G3/8-IG	10.01.23.00008

## Ordering Data Spare Parts Suction Plates for High-Temperature SPL-HT

Type	Spare Parts		Part no.
SPL-HT 35 ST G1/8-IG	Sealing ring for SPL suction plate	DR-SPL-HT 35 ST	10.01.23.00022
SPL-HT 60 ST G1/4-IG	Sealing ring for SPL suction plate	DR-SPL-HT 60 ST	10.01.23.00001
SPL-HT 90 ST G1/4-IG	Sealing ring for SPL suction plate	DR-SPL-HT 90 ST	10.01.23.00016
SPL-HT 140 ST G3/8-IG	Sealing ring for SPL suction plate	DR-SPL-HT 140 ST	10.01.23.00018

## Technical Data Suction Plates for High-Temperature SPL-HT

Type*	Suction force [N]**	Volume [cm³]	Workpiece radius min. (convex) [mm]	Evacuation rate for pu = -0.6 bar [l/min]	Weight [g]	Hose diameter (recom.) d [mm]***
SPL-HT 35 ST G1/8-IG	47	4	90	22	225	4
SPL-HT 60 ST G1/4-IG	130	12	440	32	375	6
SPL-HT 90 ST G1/4-IG	320	25	1,060	32	675	6
SPL-HT 140 ST G3/8-IG	740	50	1,700	47	1,390	9

\*The recommended suction capacity is based on an average workpiece temperature of about 300° C. We recommend testing with original workpieces.

\*\*The suction force figures are theoretical values at a vacuum of -0.6 bar and with a smooth, flat workpiece surface. They are specified without any safety factor. For the system design the safety factors should be increased at least by the factor 3.

\*\*\*The recommended hose diameter refers to a hose length of approx. 2 m

## Design Data Suction Plates for High-Temperature SPL-HT

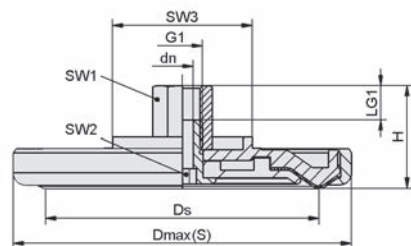

SPL-HT ST

Type*	dn [mm]	Dmax(S) [mm]**	Ds [mm]	G1	H [mm]	LG1 [mm]	SW1 [mm]	SW2 [mm]	SW3 [mm]
SPL-HT 35 ST G1/8-IG	5	53.0	35	G1/8"-F	29	12	14	5	27
SPL-HT 60 ST G1/4-IG	7	79.5	58	G1/4"-F	39	12	17	8	27
SPL-HT 90 ST G1/4-IG	7	111.5	90	G1/4"-F	39	12	17	8	46
SPL-HT 140 ST G3/8-IG	8	159.5	138	G3/8"-F	39	12	22	8	95

\*Acceptable dimensional tolerances for rubber parts concerning to DIN ISO 3302-1 M3

\*\*External dimension of the suction cup when it is pressed against the workpiece by the vacuum



# Suction Plates SPL POM-NBR

Suction area (Ø) from 40 mm to 115 mm



Suction Plates SPL POM-NBR

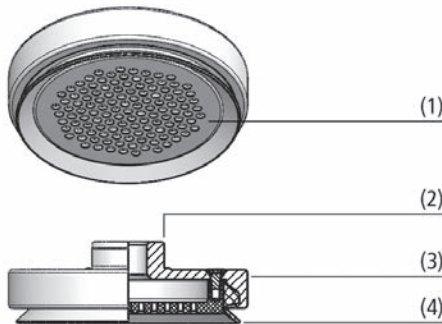

System Design Suction Plates SPL POM-NBR



Suction plate SPL POM-NBR being used for handling composite textiles

## Suitability for Industry Specific Applications

### Applications

- Suction plates for handling flexible materials e.g. prepregs or semi-finished products made of fiber composite material such as CFRP, GFRP
- Handling of sensitive workpieces that must not be deformed such as foils
- Prevention of fiber displacement by "sucking in" (no influence on the fiber orientation)
- Handling free of permanent mechanical marks

### Design

- Robust body made of aluminum (3); low construction height with spanner flat (2) for assembly
- Sealing ring (4) made of NBR
- Internal support made of POM with suction openings for evenly vacuum distribution (1)

### Our Highlights...

- Round suction plate with inner support for handling of flexible materials
- Evenly vacuum distribution due to air extraction holes
- Large air extraction holes for high flow rates

### Your Benefits...

- No "sucking in" of workpieces into the suction plate (no permanent deformation)
- Reduced energy consumption and higher resistance to lateral forces
- Evenly flow and low surface pressure; no damage of sensitive workpieces

# Suction Plates SPL POM-NBR

Suction area (Ø) from 40 mm to 115 mm

## Designation Code Suction Plates SPL POM-NBR



### 1 - Abbreviated designation

Code	Version
SPL	Flat

### 2 - Suction area

Code	Diameter in mm
40...115	ø 40 to 115

### 3 - Material

Code	Material
POM-NBR	Polyoxymethylene-Nitrile-caoutchuc

### 4 - Connection

Code	Connection
G1/8-IG	G1/8-IG (IG = female (F))
G1/4-IG	G1/4-IG

Suction plate SPL POM-NBR is available with different diameters and is delivered as a ready-to-connect product.

## Ordering Data Suction Plates SPL POM-NBR

Type	Part no.
SPL 40 POM-NBR G1/8-IG	10.01.01.13104
SPL 70 POM-NBR G1/4-IG	10.01.01.13107
SPL 115 POM-NBR G1/4-IG	10.01.01.13110

## Technical Data Suction Plates SPL POM-NBR

Type	Suction force [N]*	Volume [cm <sup>3</sup> ]	Hose diameter (recom.) d [mm]**
SPL 40 POM-NBR G1/8-IG	70	5	4
SPL 70 POM-NBR G1/4-IG	217	25	6
SPL 115 POM-NBR G1/4-IG	600	92	9

\*The specified suction forces are theoretical values at a vacuum of -0.6 bar and with a smooth, dry workpiece surface - they do not include a safety factor

\*\*The recommended hose diameter refers to a hose length of approx. 2 m

## Design Data Suction Plates SPL POM-NBR

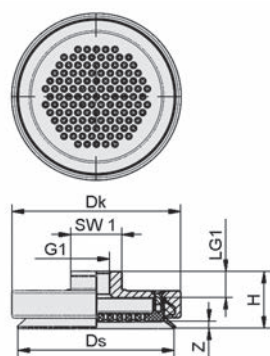

SPL POM-NBR

Type*	Dk [mm]	Ds [mm]	G1	H [mm]	LG1 [mm]	SW1 [mm]	Z (Stroke) [mm]
SPL 40 POM-NBR G1/8-IG	42	39	G1/8"-F	20.5	9.5	17	2
SPL 70 POM-NBR G1/4-IG	73	68	G1/4"-F	24.5	11.5	22	3
SPL 115 POM-NBR G1/4-IG	118	113	G1/4"-F	30.5	12.0	22	4

\*Acceptable dimensional tolerances for rubber parts concerning to DIN ISO 3302-1 M3

# Sealing Cords DI-SCHN

Dimensions from 6 mm to 12 mm



Sealing Cords DI-SCHN

## Design

- Wear-resistant sealing cords made of silicone-free foam rubber in various diameters and cross-sections

## Suitability for Industry Specific Applications

### Applications

- Sealing cord for production of special, self-made suction plates
- Adaptation of suction plates to the dimensions of special workpieces
- Handling of chipboard and MDF panels with cut-outs

### Our Highlights...

- Profiled sealing cord in any desired length
- Wide range of diameters

### Your Benefits...

- Self-construction of vacuum grippers in any desired shape and size to match special workpieces
- Suitable for a wide range of workpiece sizes and shapes



## Designation Code Sealing Cords DI-SCHN

DI-SCHN	-	8	-	MOS EPDM-20	-	SL
1		2		3		4

### 1 - Abbreviated designation

Code	Version
DI-SCHN	DI-SCHN

### 2 - Diameter

Code	Diameter in mm
6...12	ø 6 to 12

### 3 - Material

Code	Material
MOS-EPDM-20	Foam rubber made of ethylene-propylene-caoutchuc

### 4 - Product addition

Code	Type
SL	Slot

Sealing cord DI-SCHN is delivered in the desired length. Accounting unit 1 m.

# Sealing Cords DI-SCHN

Dimensions from 6 mm to 12 mm

## Ordering Data Sealing Cords DI-SCHN

Type	Part no.
DI-SCHN 6 MOS EPDM-20	10.07.04.00001
DI-SCHN 8 MOS EPDM-20	10.07.04.00002
DI-SCHN 8 MOS EPDM-20 SL	10.07.04.00005
DI-SCHN 10 MOS EPDM-20	10.07.04.00003
DI-SCHN 12 MOS EPDM-20	10.07.04.00004

## Technical Data Sealing Cords DI-SCHN

Type	Min. bending radius [mm]	Operating temperature min. [°C]	Operating temperature max. [°C]	Recom. slot width x slot depth [mm]	Length max. [m]
DI-SCHN 6 MOS EPDM-20	10	-25	70	6 x 4.2	200
DI-SCHN 8 MOS EPDM-20	10	-25	70	8 x 5.6	200
DI-SCHN 8 MOS EPDM-20 SL	10	-25	70	8 x 5.6	50
DI-SCHN 10 MOS EPDM-20	10	-25	70	10 x 7	100
DI-SCHN 12 MOS EPDM-20	10	-25	70	12 x 8.4	100

## Design Data Sealing Cords DI-SCHN

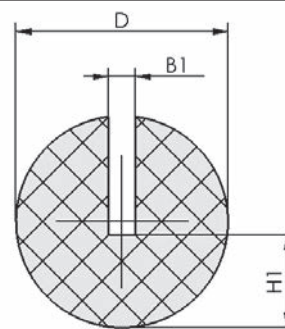
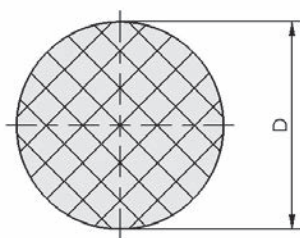

DI-SCHN 6 - 12

DI-SCHN 8 SL

Type*	B1 [mm]	D [mm]	H1 [mm]
DI-SCHN 6 MOS EPDM-20	-	6	-
DI-SCHN 8 MOS EPDM-20	-	8	-
DI-SCHN 8 MOS EPDM-20 SL	1	8	3.5
DI-SCHN 10 MOS EPDM-20	-	10	-
DI-SCHN 12 MOS EPDM-20	-	12	-

\*Acceptable dimensional tolerances for rubber parts concerning to DIN ISO 3302-1 M3

Schmalz - The Company  
Vacuum Suction Cups  
Special Grippers  
Gripping Systems  
Clamping Systems  
Mounting Elements  
Vacuum Generators  
Valve Technology  
Switches and Monitoring  
Filters and Connections  
Services  
Contact  
Glossary  
Index of Products

# Sealing Profiles DI-PROF

Dimensions from 5.5 x 8 mm to 30 x 25 mm



Sealing Profiles DI-PROF

## Design

- Robust and wear-resistant sealing profiles in various cross-sections
- Profile 2K-MOS-20: sealing strip made of foam rubber, vulcanized to support strip (supporting and sealing section made of Chloroprene CR)
- Profile 2K-SWG-20: sealing strip made of foam rubber, glued to support strip (supporting section NBR, sealing section natural rubber NK)
- High-strength supporting-section material with profile on the sides for plugging into a corresponding mounting plate



## Designation Code Sealing Profiles DI-PROF

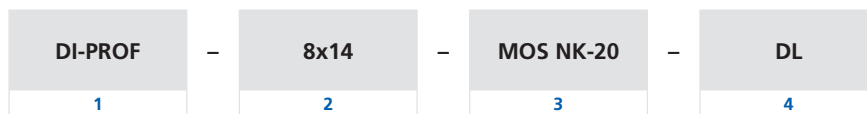

### 1 - Abbreviated designation

Code	Version
DI-PROF	DI-PROF

### 2 - Diameter

Code	WxH in mm
5.5x8...30x25	5.5x5 to 30x25

### 3 - Material

Code	Material
2K-MOS CR-20/60	Foam rubber and Chloroprene
2K-SWG NK-20/55	Foam rubber and natural rubber
MOS NK-20	Foam rubber and natural rubber
MOS EPDM-20	Foam rubber made of ethylene-propylene-cautchuc
MOS CR-20	Foam rubber and Chloroprene

### 4 - Product addition

Code	Type
DL	Sealing lip
HR	Half-round

## Suitability for Industry Specific Applications

### Applications

- Sealing profile made of two component section for production of self-made, individual suction plates
- Sealing profile for rough or structured surfaces
- Handling of barrels, sacks and similar objects with irregular surfaces

### Our Highlights...

- Sealing strip in any desired length
- Sealing profile made of two-component section

### Your Benefits...

- Self-construction of vacuum grippers in any desired shape and size to match specific workpieces
- High-strength support strip with foam rubber vulcanized or glued to it, for sealing to structured surfaces

Sealing profile DI-PROF is delivered in the desired length. Accounting unit 1 m.



# Sealing Profiles DI-PROF

Dimensions from 5.5 x 8 mm to 30 x 25 mm

## Ordering Data Sealing Profiles DI-PROF

Type	Part no.
DI-PROF 5.5x8 2K-MOS CR-20/60	10.01.01.10554
DI-PROF 9x9.7 2K-MOS CR-20/60	10.01.01.10527
DI-PROF 20x15 2K-SWG NK-20/55	10.07.04.00040
DI-PROF 30x25 2K-SWG NK-20/55	10.07.04.00041
DI-PROF 6x8 MOS NK-20 HR	10.07.04.00014
DI-PROF 8x14 MOS NK-20 DL	10.07.04.00012
DI-PROF 10x6 MOS EPDM-20	10.07.04.00006
DI-PROF 10x20 MOS EPDM-20 HR	10.07.04.00010
DI-PROF 11x23 MOS CR-20 DL	10.07.04.00015
DI-PROF 12x17 MOS EPDM-20 HR	10.07.04.00011
DI-PROF 25x20 MOS EPDM-20	10.07.04.00007

## Technical Data Sealing Profiles DI-PROF

Type	Min. bending radius [mm]	Operating temperature [°C]	Recom. slot width x slot depth [mm]	Length max. [m]
DI-PROF 5.5x8 2K-MOS CR-20/60	65	-30,0 ... 90,0	-	15
DI-PROF 9x9.7 2K-MOS CR-20/60	85	-30,0 ... 90,0	-	15
DI-PROF 20x15 2K-SWG NK-20/55	120	-35,0 ... 70,0	-	30
DI-PROF 30x25 2K-SWG NK-20/55	200	-35,0 ... 70,0	-	30
DI-PROF 6x8 MOS NK-20 HR	10	-25,0 ... 60,0	7 x 4	50
DI-PROF 8x14 MOS NK-20 DL	20	-25,0 ... 60,0	9 x 6.5	100
DI-PROF 10x6 MOS EPDM-20	10	-25,0 ... 70,0	11 x 3	50
DI-PROF 10x20 MOS EPDM-20 HR	10	-25,0 ... 70,0	11 x 10	50
DI-PROF 11x23 MOS CR-20 DL	20	-25,0 ... 70,0	12 x 11.5	50
DI-PROF 12x17 MOS EPDM-20 HR	10	-25,0 ... 70,0	13 x 10	50
DI-PROF 25x20 MOS EPDM-20	30	-25,0 ... 70,0	26 x 10	25

## Design Data Sealing Profiles DI-PROF

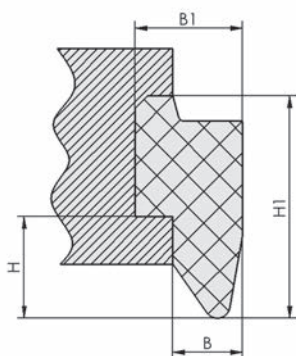

DI-PROF 5.5x8

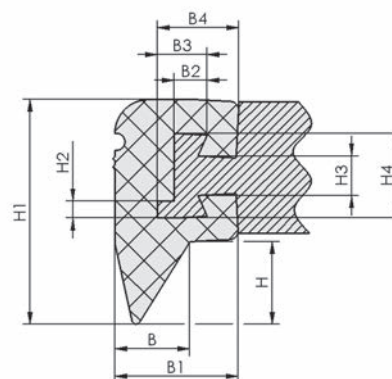

DI-PROF 9x9.7

Schmalz – The Company  
Vacuum Suction Cups  
Special Grippers  
Gripping Systems  
Clamping Systems  
Mounting Elements  
Vacuum Generators  
Valve Technology  
Switches and Monitoring  
Filters and Connections  
Services  
Contact  
Glossary  
Index of Products

# Sealing Profiles DI-PROF

Dimensions from 5.5 x 8 mm to 30 x 25 mm



## Design Data Sealing Profiles DI-PROF

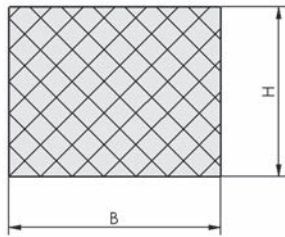

DI-PROF 10x6, 25x20

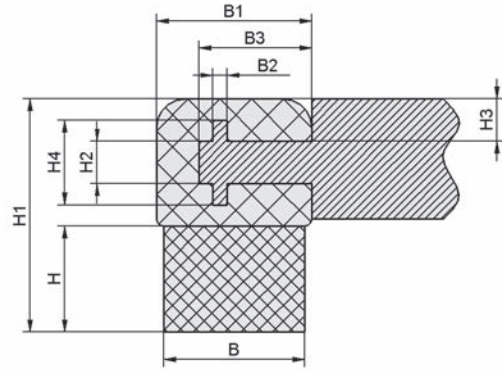

DI-PROF 20x15, 30x25

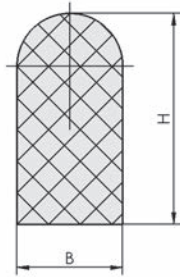

DI-PROF 6x8 - 12x17 HR

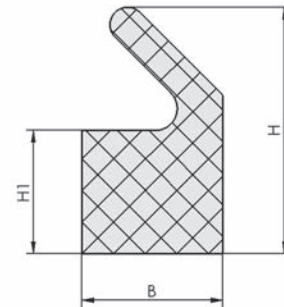

DI-PROF 8x14 DL

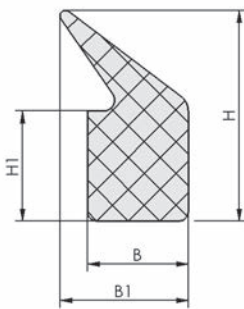

DI-PROF 11x23 DL

- Vacuum Suction Cups
- Special Grippers
- Gripping Systems
- Clamping Systems
- Mounting Elements
- Vacuum Generators
- Valve Technology
- Switches and Monitoring
- Filters and Connections
- Services
- Contact
- Glossary
- Index of Products

# Sealing Profiles DI-PROF

Dimensions from 5.5 x 8 mm to 30 x 25 mm



## Design Data Sealing Profiles DI-PROF

Type*	B [mm]	B1 [mm]	B2 [mm]	B3 [mm]	B4 [mm]	H [mm]	H1 [mm]	H2 [mm]	H3 [mm]	H4 [mm]
DI-PROF 5.5x8 2K-MOS CR-20/60	5.5	8.5	-	-	-	8.0	17.5	-	-	-
DI-PROF 9x9.7 2K-MOS CR-20/60	9.0	14.5	3.9	5.9	9.6	9.7	26.5	2	4.7	10
DI-PROF 20x15 2K-SWG NK-20/55	20.0	22.0	2.0	16.0	-	15.0	33.0	6	6.0	12
DI-PROF 30x25 2K-SWG NK-20/55	30.0	32.0	2.0	24.0	-	25.0	53.0	8	10.0	17
DI-PROF 6x8 MOS NK-20 HR	6.0	-	-	-	-	8.0	-	-	-	-
DI-PROF 8x14 MOS NK-20 DL	8.0	-	-	-	-	14.0	7.0	-	-	-
DI-PROF 10x6 MOS EPDM-20	10.0	-	-	-	-	6.0	-	-	-	-
DI-PROF 10x20 MOS EPDM-20 HR	10.0	-	-	-	-	20.0	-	-	-	-
DI-PROF 11x23 MOS CR-20 DL	11.0	14.0	-	-	-	23.0	12.0	-	-	-
DI-PROF 12x17 MOS EPDM-20 HR	12.0	-	-	-	-	17.0	-	-	-	-
DI-PROF 25x20 MOS EPDM-20	25.0	-	-	-	-	20.0	-	-	-	-

\*Acceptable dimensional tolerances for rubber parts concerning to DIN ISO 3302-1 M3

- Vacuum Suction Cups
- Special Grippers
- Gripping Systems
- Clamping Systems
- Mounting Elements
- Vacuum Generators
- Valve Technology
- Switches and Monitoring
- Filters and Connections
- Services
- Contact
- Glossary
- Index of Products





# Filter Discs FD

Diameter (Ø) from 16 mm to 55 mm



Filter Discs FD

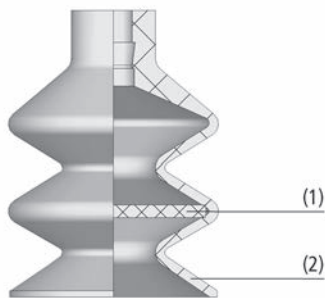

System Design Filter Discs FD

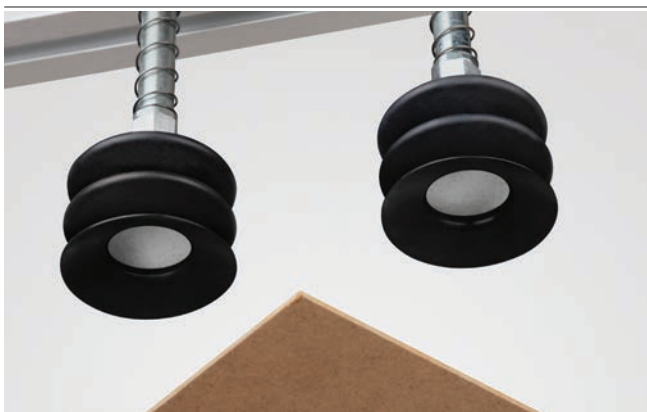

Bellows suction cups with filter discs FD being used for handling wooden boards

## Suitability for Industry Specific Applications

### Applications

- Filter disc to protect the vacuum system from dust and dirt, without changing the flow restrictor
- Filter disc prevents the workpiece from being sucked into the suction cup

### Design

- Filter disc (1) made of porous polyethylene (sinter PE)
- Filtration grade 120 µm
- Can be placed directly into the suction cup (2)

### Our Highlights...

- Placed directly in a fold of the suction cup
- Wide variety of diameters
- Stable filter disc

### Your Benefits...

- Dirt and dust is filtered out directly at the workpiece
- Wide range of application possibilities for suction cup series FGA and FG
- High intrinsic stability of the suction cup; prevents the workpiece from being sucked in

# Filter Discs FD

Diameter (Ø) from 16 mm to 55 mm

## Designation Code Filter Discs FD

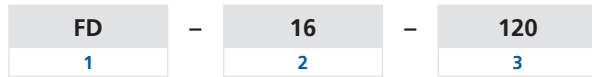

### 1 – Abbreviated designation

Code	Version
FD	FD

### 2 – Diameter

Code	Diameter in mm
16...55	ø 16 to 55

### 3 – Porosity

Code	Porosity in µm
120	120

Filter discs FD is delivered in the desired diameter.

## Ordering Data Filter Discs FD

Type	Part no.
FD 16 120	10.01.06.02565
FD 18 120	10.01.06.02567
FD 22 120	10.01.06.02566
FD 27 120	10.01.06.02571
FD 30 120	10.01.06.02568
FD 34 120	10.01.06.02572
FD 38 120	10.01.06.02569
FD 44 120	10.01.06.02573
FD 55 120	10.01.06.02570

## Technical Data Filter Discs FD

Type	Filter pore size [µm]	For suction cup type
FD 16 120	120	FG 20/FGA 20
FD 18 120	120	FG 25/FGA 25
FD 22 120	120	FGA 22
FD 27 120	120	FG 32
FD 30 120	120	FGA 33
FD 34 120	120	FG 42
FD 38 120	120	FGA 43
FD 44 120	120	FG 52
FD 55 120	120	FGA 53

# Filter Discs FD

Diameter (Ø) from 16 mm to 55 mm



## Design Data Filter Discs FD

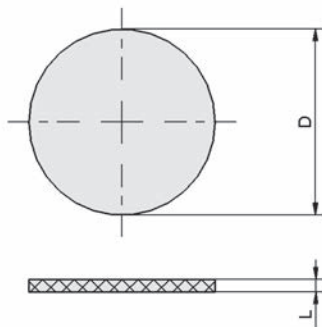

FD

Type	D [mm]	L [mm]
FD 16 120	16	1.5
FD 18 120	18	1.5
FD 22 120	22	1.5
FD 27 120	27	1.5
FD 30 120	30	1.5
FD 34 120	34	1.5
FD 38 120	38	1.5
FD 44 120	44	1.5
FD 55 120	55	1.5

Schmalz –  
The Company

Vacuum  
Suction Cups

Special  
Grippers

Gripping  
Systems

Clamping  
Systems

Mounting  
Elements

Vacuum  
Generators

Valve  
Technology

Switches and  
Monitoring

Filters and  
Connections

Services

Contact

Glossary

Index of  
Products



# Suction Cup Inserts SPI PEEK

Suction area (Ø) from 6 mm to 32 mm



## Suitability for Industry Specific Applications

### Applications

- Suction cup inserts for gentle and mark-free gripping and depositing of smooth workpieces
- Application with crystalline solar cells, thin-film modules and wafers / substrates in the semiconductor area
- Handling of glass such as display glass, thin glass with thickness less than 0.1 mm or coated glass without leaving a chemical fingerprint by elastomers
- Use in combination with bellows suction cups FGA (1.5 folds) and FG (2.5 folds)



Suction Cup Inserts SPI PEEK

### Design

- Suction cup inserts made of PEEK with support structure and vacuum channels
- Inserts are tool-free clipped into the lower suction cup fold of bellows suction cups

### Our Highlights...

- Suction cup inserts made of PEEK
- Structure with defined contact area, flow grooves and vacuum channels
- Smart vacuum distribution on the suction surface

### Your Benefits...

- Non-marking and gentle handling of thin, flat workpieces without leaving chemical fingerprints
- Defined and low surface pressure on the workpiece surface
- High leakage compensation for high effective suction forces

## Designation Code Suction Cup Inserts SPI PEEK



**1** – Abbreviated designation

Code	Version
SPI	SPI

**2** – Diameter

Code	Diameter in mm
6...32	ø 6 to 32

**3** – Material

Code	Material
PEEK	Polyetheretherketon

Suction cup insert SPI PEEK is delivered with the desired diameter.



Schmalz – The Company  
 Vacuum Suction Cups  
 Special Grippers  
 Gripping Systems  
 Clamping Systems  
 Mounting Elements  
 Vacuum Generators  
 Valve Technology  
 Switches and Monitoring  
 Filters and Connections  
 Services  
 Contact  
 Glossary  
 Index of Products

# Suction Cup Inserts SPI PEEK

Suction area (Ø) from 6 mm to 32 mm



## Ordering Data Suction Cup Inserts SPI PEEK

Type	Part no.
SPI 6	10.01.06.03279
SPI 9	10.01.06.03280
SPI 11	10.01.06.03281
SPI 14	10.01.06.03282
SPI 17	10.01.06.03283
SPI 18	10.01.06.03284
SPI 21	10.01.06.03285
SPI 25	10.01.06.03286
SPI 32	10.01.06.03287



## Technical Data Suction Cup Inserts SPI PEEK

Type*	For suction cup type**
SPI 6	FG 5/FGA 6
SPI 9	FG 9
SPI 11	FGA 11
SPI 14	FG 12/FG 14/FGA 14
SPI 17	FG 18/FGA 16
SPI 18	FGA 20
SPI 21	FG 20/FGA 22
SPI 25	FG 25/FGA 25
SPI 32	FG 32/FGA 33

\*Suction capacity of min. 2 l/min is recommended. An experiment has to be carried out with the original workpiece and suction cups to define the required suction power for the application. Frictional force is reduced during vertical applications.

\*\*Suitable suction cups are to find in chapter Vacuum Suction Cups.



## Design Data Suction Cup Inserts SPI PEEK

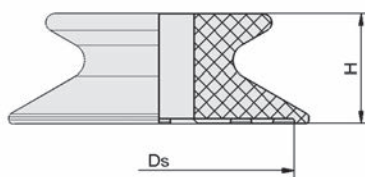

SPI PEEK

Type	Ds [mm]	H [mm]
SPI 6	5.2	3.3
SPI 9	7.4	3.5
SPI 11	8.8	5.1
SPI 14	11.8	6.3
SPI 17	14.8	6.7
SPI 18	16.0	5.3
SPI 21	19.0	6.3
SPI 25	22.6	10.1
SPI 32	29.0	10.3



# Suction Cup Covers SU

Diameter (Ø) from 25 mm to 360 mm

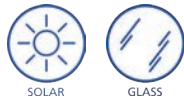

## Suitability for Industry Specific Applications

### Applications

- Suction cup cover for handling sensitive, flat and smooth workpieces (coated, processed or painted) to prevent marks and damage
- For use in manufacturing, processing and transportation, for example in the glass and solar industry
- Used in combination with suction cups and suction plates

### Design

- Suction cup cover SU is made of a robust fleece material that is highly tear-resistant as well as extremely resistant to chemicals
- The material is abrasion-free and enables gentle handling of workpieces
- The cover (2) can be easily slid over the suction cup or the suction plate (1) and fastened with the integrated rubber band
- With diameters from 25 to 360 mm, the covers are designed to match the corresponding diameter ranges of the suction plates and suction cups



Suction Cup Covers SU

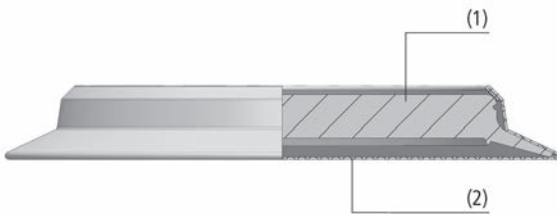

System Design Suction Cup Covers SU

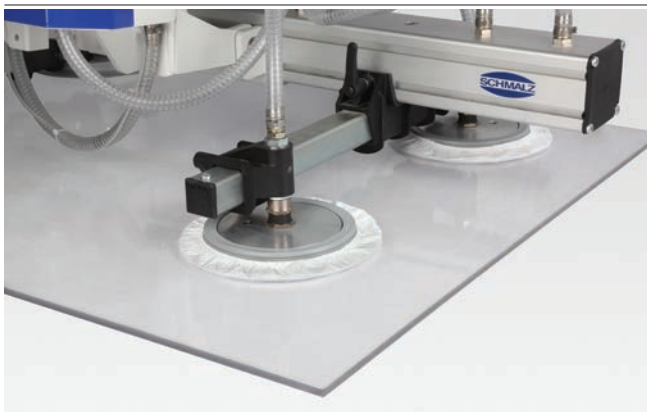

Suction cup covers SU being used for handling sensitive glass sheets

### Our Highlights...

- Suction cup cover made of special fleece material (PP/PE)
- Integrated rubber band
- Large range of diameters

### Your Benefits...

- No marks on sensitive workpieces (e.g. glass), highly tear-resistant
- Quick and easy installation on suction plates and suction cups
- Installation on flat suction cups, bellows suction cups and suction plates

- Schmalz – The Company
- Vacuum Suction Cups
- Special Grippers
- Gripping Systems
- Clamping Systems
- Mounting Elements
- Vacuum Generators
- Valve Technology
- Switches and Monitoring
- Filters and Connections
- Services
- Contact
- Glossary
- Index of Products

# Suction Cup Covers SU

Diameter (Ø) from 25 mm to 360 mm



## Designation Code Suction Cup Covers SU

<b>SU</b>	–	<b>120</b>
<b>1</b>		<b>2</b>

### 1 – Abbreviated designation

Code	Version
SU	SU

### 2 – Diameter

Code	Diameter in mm
25...360	ø 25 to 360

Suction cup cover SU is delivered in the desired diameter.



## Ordering Data Suction Cup Covers SU

Type	Part no.
SU 25	10.01.01.13584
SU 30	10.01.01.12889
SU 40	10.01.01.12856
SU 50	10.01.01.12837
SU 60	10.01.01.13585
SU 70	10.01.01.12838
SU 80	10.01.01.12839
SU 100	10.01.01.12840
SU 120	10.01.01.12437
SU 160	10.01.01.12438
SU 210	10.01.01.12439
SU 230	10.01.01.12440
SU 280	10.01.01.12485
SU 300	10.01.01.12843
SU 360	10.01.01.12842



## Technical Data Suction Cup Covers SU

Type*	Weight [g]	Clamping range [mm]
SU 25	0.3	25.0 ... 30.0
SU 30	0.4	27.0 ... 35.0
SU 40	0.5	35.0 ... 45.0
SU 50	0.7	45.0 ... 60.0
SU 60	1.2	60.0 ... 70.0
SU 70	1.3	65.0 ... 80.0
SU 80	1.7	80.0 ... 100.0
SU 100	2.2	110.0 ... 115.0
SU 120	2.8	115.0 ... 130.0
SU 160	4.3	150.0 ... 180.0
SU 210	5.2	210.0 ... 220.0
SU 230	5.8	230.0 ... 250.0
SU 280	7.6	270.0 ... 300.0
SU 300	10.8	300.0 ... 330.0
SU 360	12.0	360.0 ... 400.0

\*In vertical applications with a suction plate or cup, the lateral force sinks by up to 70 %. The vacuum generator must be able to provide 10 % more suction power.



# Suction Cup Covers SU

Diameter (Ø) from 25 mm to 360 mm



## Design Data Suction Cup Covers SU

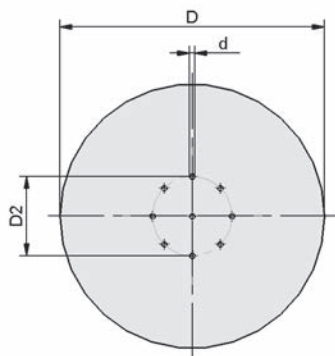

SU

Type	d [mm]	D [mm]	D2 [mm]
SU 25	3	28	-
SU 30	3	39	-
SU 40	5	47	30
SU 50	5	57	30
SU 60	5	67	30
SU 70	5	77	30
SU 80	5	88	30
SU 100	5	111	50
SU 120	5	132	50
SU 160	5	170	50
SU 210	5	200	50
SU 230	5	219	50
SU 280	5	267	110
SU 300	5	310	110
SU 360	5	335	110



- Vacuum Suction Cups
- Special Grippers
- Gripping Systems
- Clamping Systems
- Mounting Elements
- Vacuum Generators
- Valve Technology
- Switches and Monitoring
- Filters and Connections
- Services
- Contact
- Glossary
- Index of Products



# Protection Covers PC

Diameter (Ø) 125 mm to 400 mm



Protection Covers PC

## Design

- Robust and tear-resistant material, resistant to external environmental influences
- Slid over suction cups / suction plates and fastened with the integrated elastic band
- Diameters of the covers are designed to match the corresponding diameter ranges of the suction plates and suction cups

## Suitability for Industry Specific Applications

### Applications

- High quality protection cover for suction plates during storage or when not in use
- Protection against pollution (dust or moisture) and aging (by ozone or UV impact) in outdoor areas
- Use with suction plates and suction cups such as SPU and SGF
- Use with manual glass lifting devices indoors and outdoors during storage and transport

### Our Highlights...

- High quality protection cover for suction plates
- Integrated elastic band
- Large range of diameters

### Your Benefits...

- Reduced risk of contamination and damage of the sealing lip during storage
- Fast and easy installation on suction plates and suction cups
- Installation on flat suction cups, bellows suction cups and suction plates



## Designation Code Protection Covers PC

PC	–	125
1		2

1 – Abbreviated designation

Code	Version
PC	PC

2 – Diameter

Code	Diameter in mm
125...400	ø 125 to 400

Protection cover PC is delivered with the desired diameter.

# Protection Covers PC

Diameter (Ø) 125 mm to 400 mm

Schmalz – The Company  
Vacuum Suction Cups  
Special Grippers  
Gripping Systems  
Clamping Systems  
Mounting Elements  
Vacuum Generators  
Valve Technology  
Switches and Monitoring  
Filters and Connections  
Services  
Contact  
Glossary  
Index of Products

## Ordering Data Protection Covers PC

Type	Part no.
PC 125	10.01.01.13086
PC 150	10.01.01.13087
PC 175	10.01.01.13088
PC 200	10.01.01.13089
PC 250	10.01.01.13090
PC 300	10.01.01.13091
PC 350	10.01.01.13092
PC 400	10.01.01.13093

## Technical Data Protection Covers PC

Type*	Clamping range [mm]
PC 125	110.0 ... 135.0
PC 150	135.0 ... 165.0
PC 175	165.0 ... 190.0
PC 200	190.0 ... 220.0
PC 250	220.0 ... 275.0
PC 300	275.0 ... 325.0
PC 350	325.0 ... 375.0
PC 400	375.0 ... 425.0

\*Suction cup protection covers PC are designed for the use with suction cups and suction plates that are out of use. They cannot be used during handling.

## Design Data Protection Covers PC

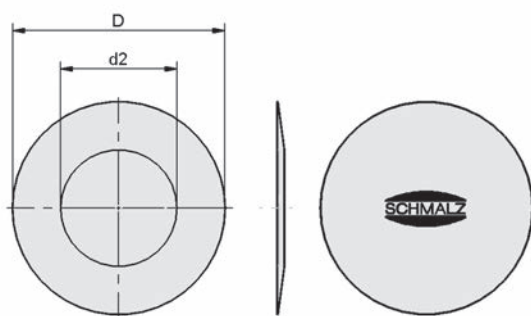

PC 125 - 400

Type	D [mm]	d2 [mm]
PC 125	125	65
PC 150	150	75
PC 175	175	90
PC 200	200	100
PC 250	250	125
PC 300	300	150
PC 350	350	175
PC 400	400	200

# Sealing Rings DR-MOS SI

Diameter (Ø) from 20 mm to 88 mm



Sealing Rings DR-MOS SI

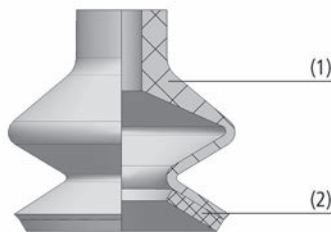

System Design Sealing Rings DR-MOS SI



Standard suction cup with sealing ring DR-MOS SI being used for handling structured plastic parts

## Suitability for Industry Specific Applications

### Applications

- Sealing ring made from special foam for an optimum sealing on structured surfaces
- Used on structured surfaces (studded, rippled or rough) where suction cups hardly seal or cannot seal at all
- Handling of packaging materials and flat or uneven workpieces with structured surfaces such as foil packed products or plastic components
- Can be used as an accessory for suction cup series FG and FGA made from silicone

### Design

- Sealing ring of high-quality silicone foam (2) for gluing onto the silicone suction cup (1)
- Available in a variety of diameters and thicknesses, suitable for standard suction cup series FGA (1.5 folds) and FG (2.5 folds)
- Material connection with silicone adhesive

### Our Highlights...

- Foam rings for gluing onto bellows suction cup
- Available in a variety of diameters and thicknesses
- Silicone adhesive available as accessory

### Your Benefits...

- Optimal sealing on structured surfaces
- Wide range of application possibilities for standard suction cup series FGA (1.5 folds) and FG (2.5 folds)
- Secure mounting and connection to the suction cup



# Sealing Rings DR-MOS SI

Diameter (Ø) from 20 mm to 88 mm

## Designation Code Sealing Rings DR-MOS SI



### 1 – Abbreviated designation

Code	Version
DR	DR

### 2 – Diameter

Code	Diameter in mm
20/10...88/64	ø 20/10 to 88/64 (outside/inside)

### 3 – Height

Code	Height in mm
x2	2
x5	5

### 4 – Material

Code	Material
MOS SI-15	Foam rubber and silicone

Sealing profile DR-MOS SI is delivered with the desired diameter.

Available accessories: silicone adhesive

## Ordering Data Sealing Rings DR-MOS SI

Type	Part no.
DR 20/10x2 MOS SI-15	10.01.06.02618
DR 22.5/13x2 MOS SI-15	10.01.06.02614
DR 32/19x2 MOS SI-15	10.01.06.02615
DR 42/20x5 MOS SI-15	10.01.06.02616
DR 52/33x5 MOS SI-15	10.01.06.02548
DR 62/42x5 MOS SI-15	10.01.06.02617
DR 78/54x5 MOS SI-15	10.01.06.02619
DR 88/64x5 MOS SI-15	10.01.06.02620

## Ordering Data Accessories Sealing Rings DR-MOS SI

Type	Part no.
Silicone adhesive	27.03.04.00014

## Technical Data Sealing Rings DR-MOS SI

Type	Material type	Temperature resistance [°C]	Color
DR 20/10x2 MOS SI-15	Foam rubber	180	beige
DR 22.5/13x2 MOS SI-15	Foam rubber	180	beige
DR 32/19x2 MOS SI-15	Foam rubber	180	beige
DR 42/20x5 MOS SI-15	Foam rubber	180	beige
DR 52/33x5 MOS SI-15	Foam rubber	180	beige
DR 62/42x5 MOS SI-15	Foam rubber	180	beige
DR 78/54x5 MOS SI-15	Foam rubber	180	beige
DR 88/64x5 MOS SI-15	Foam rubber	180	beige

# Sealing Rings DR-MOS SI

Diameter (Ø) from 20 mm to 88 mm



## Design Data Sealing Rings DR-MOS SI

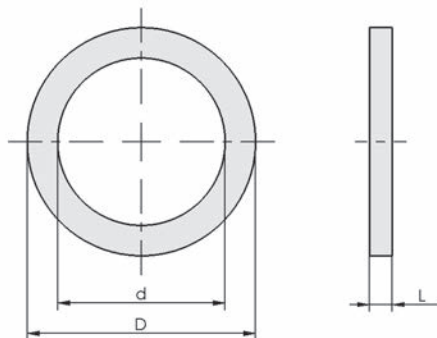

DR-MOS SI

Type	d [mm]	D [mm]	L [mm]
DR 20/10x2 MOS SI-15	10	20.0	2
DR 22.5/13x2 MOS SI-15	13	22.5	2
DR 32/19x2 MOS SI-15	19	32.0	2
DR 42/20x5 MOS SI-15	20	42.0	5
DR 52/33x5 MOS SI-15	33	52.0	5
DR 62/42x5 MOS SI-15	42	62.0	5
DR 78/54x5 MOS SI-15	54	78.0	5
DR 88/64x5 MOS SI-15	64	88.0	5

Schmalz –  
The Company

Vacuum  
Suction Cups

Special  
Grippers

Gripping  
Systems

Clamping  
Systems

Mounting  
Elements

Vacuum  
Generators

Valve  
Technology

Switches and  
Monitoring

Filters and  
Connections

Services

Contact

Glossary

Index of  
Products



# Special Grippers

Schmalz –  
The Company

Vacuum  
Suction Cups

**Special  
Grippers**

Gripping  
Systems

Clamping  
Systems

Mounting  
Elements

Vacuum  
Generators

Valve  
Technology

Switches and  
Monitoring

Filters and  
Connections

Services

Contact

Glossary

Index of  
Products



## Selection Aid

Page



### Selection by Workpiece

242

## Floating Suction Cups



### Floating Suction Cups SBS

- Diameter: 20 to 120 mm
- Holding force: 2.0 to 104.0 N
- Rubber buffer on the bottom side of the suction cup



Floating suction cup for low-contact handling of fragile workpieces such as paper, film, printed circuit boards or wafers and solar cells.

243

## Magnetic Grippers



### Magnetic Grippers SGM

- Diameter: 30 to 70 mm
- Holding force: 35 to 290 N



Special gripper with permanent magnet for safe handling of magnetic workpieces such as perforated metal sheets.

248



### Magnetic Grippers SGM-HP/-HT

- Diameter: 20 to 50 mm
- Holding force: 28 to 560 N



Special gripper with permanent magnet for safe handling of magnetic workpieces such as perforated metal sheets.

252

## Needle Grippers



### Electric Needle Grippers SNGi-AE

- Needle diameter: 0.8 mm or 1.2 mm
- No. of needles: 10
- Needle stroke: 3 mm to 20 mm



Electric needle gripper with automatic adjustable stroke and IO-Link interface for materials that are difficult to handle with vacuum.

256

# Special Grippers

## Overview of Section



At a Glance

Schmalz – The Company  
Vacuum Suction Cups  
Special Grippers  
Gripping Systems  
Clamping Systems  
Mounting Elements  
Vacuum Generators  
Valve Technology  
Switches and Monitoring  
Filters and Connections  
Services  
Contact  
Glossary  
Index of Products

Page



### Needle Grippers SNG-AP

- Needle diameter: 0.8 mm or 1.2 mm
- No. of needles: 10
- Needle stroke: 3 mm to 20 mm (variable)



Pneumatic needle gripper in compact design with manually adjustable stroke for materials that are difficult to handle with vacuum.

259



### Needle Grippers SNG-V

- Needle diameter: 0.8 mm to 1.5 mm
- Number of needles: 6 and 10
- Needle stroke: 0 mm to 25 mm (variable)



Needle gripper with intersecting needles and manual, continuously adjustable stroke for materials that are difficult to grip like composite textiles and much more.

262



### Needle Grippers SNG-M

- Needle diameter: 0.8 mm
- Number of needles: 4
- Needle stroke: 3.0 mm



Needle gripper with an especially compact design for materials which are difficult to handle with vacuum.

266

## Wafer Grippers



### Wafer Grippers SWGm

- Dimensions: 125 x 125 mm and 156 x 156 mm
- Selectable base model with axial exhaust air or sideways exhaust air



Wafer gripper for extremely quick and gentle handling of wafers and solar cells with maximum process reliability.

269

## Flow Grippers



### Flow Grippers SCG

- Suction rate: 270 l/min to 650 l/min
- Diameter suction plate: 20 to 60 mm

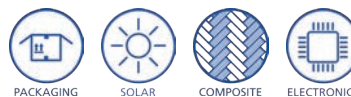

Flow gripper with integrated vacuum generation and high flow rate for handling fragile workpieces with unstable shapes.

274

## Thin Glass Grippers



### Thin Glass Grippers STGG

- Suction area: 100 x 55 mm and 170 x 105 mm
- Material suction area: PEEK
- Suction rate: 31 to 235 l/min

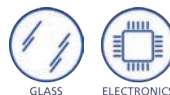

Area gripper for gentle, contamination-free and extremely dynamic handling of sensitive workpieces in fully automated processes.

278



# Overview of Section

At a Glance

## Feed Ejectors

Page



### Feed Ejectors SEC

- Suction capacity up to 8,640 l/min
- Diameter: 6 to 75 mm



Ejector with high evacuation volume for applying suction to very porous parts and for transportation of bulk materials.

282

## 3D Gripping and Clamping Systems



### Suction-Cup Balance SSCB

- Clamping and gripping system for free-form 3D contours
- Precise, accurate workpiece positioning enabled by automated assembly processes



Suction cup balance SSCB for clamping, gripping processes in automated production. For components made of glass, composite textiles or metal.

285

Schmalz – The Company

Vacuum Suction Cups

Special Grippers

Gripping Systems

Clamping Systems

Mounting Elements

Vacuum Generators

Valve Technology

Switches and Monitoring

Filters and Connections

Services









Contact

Glossary

Index of Products

### Selection by Workpiece

For workpieces that are difficult or impossible to handle with suction cups, the “Special Grippers” section offers alternatives. Below are a few sample applications to assist you in selecting the appropriate special gripper:

Application areas	Workpiece	Special gripper Type	Product properties
 METAL	Ferromagnetic sheet metal, perforated plates	Magnetic gripper SGM	<ul style="list-style-type: none"> <li>• Permanent magnet used for handling</li> <li>• Friction ring for absorbing lateral forces</li> <li>• Bistable design</li> </ul>
 GLASS	Thin, delicate glass such as display glass	Thin glass gripper STGG	<ul style="list-style-type: none"> <li>• Large contact surface for delicate handling</li> <li>• Available with integrated vacuum generation</li> <li>• High flow rate for secure gripping</li> </ul>
 ELECTRONICS	Delicate components such as blank printed-circuit boards	Floating suction cup SBS	<ul style="list-style-type: none"> <li>• Low-contact handling</li> <li>• High leakage compensation</li> <li>• Elastomer buffer on the bottom to absorb lateral forces</li> <li>• Integrated vacuum generation</li> </ul>
		Flow gripper SCG	<ul style="list-style-type: none"> <li>• Higher flow rate for a secure grip on even porous workpieces</li> <li>• Large contact surface for delicate handling</li> <li>• Integrated vacuum generation</li> </ul>
 SOLAR	Solar components such as wafers and solar cells	Wafer gripper SWGm	<ul style="list-style-type: none"> <li>• Extremely fast and precise handling</li> <li>• Dimensions for 125 x 125 mm and 156 x 156 mm wafer sizes</li> <li>• Integrated vacuum generation with high suction rate</li> </ul>
		Floating suction cup SBS	<ul style="list-style-type: none"> <li>• Low-contact handling</li> <li>• High catching distance of the workpiece</li> </ul>
 PLASTICS	Thin workpieces such as plastic films and paper	Floating suction cup SBS	<ul style="list-style-type: none"> <li>• Low-contact handling</li> <li>• High leakage compensation</li> <li>• Elastomer buffer on the bottom to absorb lateral forces</li> <li>• Integrated vacuum generation</li> </ul>
		Flow gripper SCG	<ul style="list-style-type: none"> <li>• Higher flow rate for a secure grip on even porous workpieces</li> <li>• Large contact surface for delicate handling</li> <li>• Integrated vacuum generation</li> </ul>
 PACKAGING		Wafer gripper SWGm	<ul style="list-style-type: none"> <li>• Extremely fast and precise handling</li> <li>• Integrated vacuum generation with high suction rate</li> </ul>
		Thin glass gripper STGG	<ul style="list-style-type: none"> <li>• Large contact surface for delicate handling</li> <li>• Available with integrated vacuum generation</li> <li>• High flow rate for secure gripping</li> </ul>
		Needle gripper SNG/SNGi	<ul style="list-style-type: none"> <li>• Variable needle stroke and needle diameter for adaptation to different workpieces</li> <li>• Electrical design with continuously adjustable stroke</li> </ul>
 SOLAR	Porous, flexible workpieces such as technical textiles for fiber composites, foams, construction materials, non-woven fabric	Floating suction cup SBS	<ul style="list-style-type: none"> <li>• Separation of porous workpieces</li> <li>• Low-contact handling</li> <li>• High leakage compensation</li> <li>• Integrated vacuum generation</li> </ul>
		Flow gripper SCG	<ul style="list-style-type: none"> <li>• Higher flow rate for a secure grip on even porous workpieces</li> <li>• Large contact surface for delicate handling</li> <li>• Integrated vacuum generation</li> </ul>
 COMPOSITE			

# Floating Suction Cups SBS

Diameter (Ø) from 20 mm to 120 mm

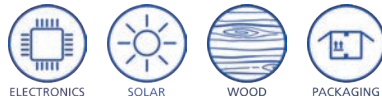

Floating Suction Cups SBS

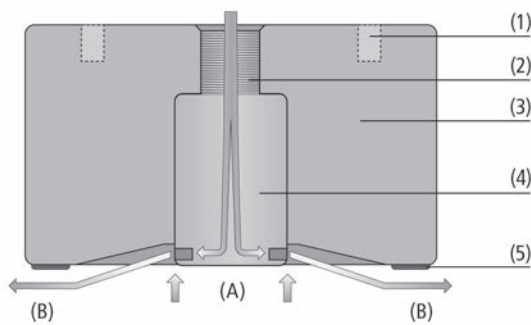

System Design Floating Suction Cups SBS



Floating suction cups SBS being used for handling thin wood veneer

## Suitability for Industry Specific Applications

### Applications

- Floating suction cup for handling and separation of extremely thin workpieces without permanent deformation (e.g. film, paper, wood veneer)
- Handling of very porous workpieces (e.g. printed circuit board)
- Handling of highly sensitive workpieces (e.g. wafer, solar cells)

### Design

- Connection directly via four mounting threads (1) on the top side; vertical (2) and horizontal compressed air connections
- Anodized aluminum body with integrated Bernoulli nozzle (3)
- Streaming element (4) in two versions: Standard Flow SF for airtight workpieces and High Flow HF for higher leakage compensation on porous workpieces
- Mark-free rubber buffer of special material HT1 on the bottom side of the suction cup (5)
- Optional available with central support
- Vacuum (A), exhaust-air (B)

### Our Highlights...

- Integrated vacuum generation on the Bernoulli principle
- Suction cup "floats" on an air cushion
- High volume flow rate at a low vacuum
- No air is drawn through the workpiece
- Elastomer buffer made of HT1 on the bottom side

### Your Benefits...

- Operating without ejector
- Low-contact handling
- Very good compensation of leakages
- Reliable separation of thin, porous workpieces
- Absorption of lateral forces

# Floating Suction Cups SBS

Diameter (Ø) from 20 mm to 120 mm

## Designation Code Floating Suction Cups SBS



### 1 – Abbreviated designation

Code	Version
SBS	SBS

### 2 – Diameter

Code	Diameter in mm
20...120	ø 20 to 120

### 3 – Streaming element

Code	Type
HF	High Flow
SF	Standard Flow

### 4 – Connection

Code	Connection
M5-IG	M5-IG (IG = female (F))
G1/8-IG	G1/8-IG

### 5 – Product addition

Code	Type
CS	Central support

Floating suction cup SBS is delivered assembled. The assembly consists of:

- Floating suction cup of type SBS – available in various diameters
- Elastomer buffer made of the material HT1
- Optional product addition: central support

Available spare parts: rubber buffer

## Ordering Data Floating Suction Cups SBS

Type	Part no.
SBS 20 HF M5-IG	10.01.01.12650
SBS 20 SF M5-IG	10.01.01.12633
SBS 30 HF M5-IG	10.01.01.12651
SBS 30 SF M5-IG	10.01.01.12636
SBS 40 HF G1/8-IG	10.01.01.12653
SBS 40 SF G1/8-IG	10.01.01.12638
SBS 40 SF G1/8-IG CS	10.01.01.12776
SBS 60 HF G1/8-IG	10.01.01.12655
SBS 60 SF G1/8-IG	10.01.01.12641
SBS 60 SF G1/8-IG CS	10.01.01.12777
SBS 100 HF G1/8-IG	10.01.01.12689
SBS 100 SF G1/8-IG	10.01.01.12688
SBS 120 HF G1/8-IG	10.01.01.13139
SBS 120 SF G1/8-IG	10.01.01.13136

## Ordering Data Spare Parts Floating Suction Cups SBS

Type	Spare Parts		Part no.
SBS 20 HF M5-IG	Rubber buffer	REIB-FL SBS HT1-60	10.01.01.12585
SBS 20 SF M5-IG	Rubber buffer	REIB-FL SBS HT1-60	10.01.01.12585
SBS 30 HF M5-IG	Rubber buffer	REIB-FL SBS HT1-60	10.01.01.12585
SBS 30 SF M5-IG	Rubber buffer	REIB-FL SBS HT1-60	10.01.01.12585
SBS 40 HF G1/8-IG	Rubber buffer	REIB-FL SBS HT1-60	10.01.01.12593
SBS 40 SF G1/8-IG	Rubber buffer	REIB-FL SBS HT1-60	10.01.01.12593



Diameter (Ø) from 20 mm to 120 mm



## Ordering Data Spare Parts Floating Suction Cups SBS

Type	Spare Parts		Part no.
SBS 40 SF G1/8-IG CS	Rubber buffer	REIB-FL SBS HT1-60	10.01.01.12593
SBS 60 HF G1/8-IG	Rubber buffer	REIB-FL SBS HT1-60	10.01.01.12593
SBS 60 SF G1/8-IG	Rubber buffer	REIB-FL SBS HT1-60	10.01.01.12593
SBS 60 SF G1/8-IG CS	Rubber buffer	REIB-FL SBS HT1-60	10.01.01.12593
SBS 100 HF G1/8-IG	Rubber buffer	REIB-FL SBS HT1-60	10.01.01.12593
SBS 100 SF G1/8-IG	Rubber buffer	REIB-FL SBS HT1-60	10.01.01.12593
SBS 120 HF G1/8-IG	Rubber buffer	REIB-FL SBS HT1-60	10.01.01.12593
SBS 120 SF G1/8-IG	Rubber buffer	REIB-FL SBS HT1-60	10.01.01.12593

Type	Spare Parts		Part no.
SBS 40 SF G1/8-IG CS	Central support	REIB-FL SBS HT1-60	10.01.01.12780
SBS 60 SF G1/8-IG CS	Central support	REIB-FL SBS HT1-60	10.01.01.12780



## Technical Data Floating Suction Cups SBS

Type	Holding force [N]*	Air consumption [l/min]**	Pressure range (operating pressure) [bar]	Operating temperature [°C]	Weight [g]
SBS 20 HF M5-IG	3.0	140	1.0 ... 6.0	0 ... 80	12
SBS 20 SF M5-IG	2.0	100	1.0 ... 6.0	0 ... 80	12
SBS 30 HF M5-IG	5.0	140	1.0 ... 6.0	0 ... 80	31
SBS 30 SF M5-IG	4.0	100	1.0 ... 6.0	0 ... 80	31
SBS 40 HF G1/8-IG	10.5	190	1.0 ... 6.0	0 ... 80	51
SBS 40 SF G1/8-IG	6.5	100	1.0 ... 6.0	0 ... 80	51
SBS 40 SF G1/8-IG CS	6.5	100	1.0 ... 6.0	0 ... 80	53
SBS 60 HF G1/8-IG	18.5	225	1.0 ... 6.0	0 ... 80	118
SBS 60 SF G1/8-IG	13.0	150	1.0 ... 6.0	0 ... 80	118
SBS 60 SF G1/8-IG CS	13.0	150	1.0 ... 6.0	0 ... 80	120
SBS 100 HF G1/8-IG	55.5	420	1.0 ... 6.0	0 ... 80	295
SBS 100 SF G1/8-IG	46.0	225	1.0 ... 6.0	0 ... 80	295
SBS 120 HF G1/8-IG	104.0	420	1.0 ... 6.0	0 ... 80	390
SBS 120 SF G1/8-IG	89.0	225	1.0 ... 6.0	0 ... 80	390

\*The values provided are based on an operating pressure of 5 bar, measured on a suction-tight workpiece. The actual values may differ depending on the properties of the workpiece.

\*\*The values provided are based on an operating pressure of 5 bar, measured on a suction-tight workpiece. The actual values may differ depending on the properties of the workpiece.

# Floating Suction Cups SBS

Diameter (Ø) from 20 mm to 120 mm



## Performance Data Floating Suction Cups SBS

- Schmalz – The Company
- Vacuum Suction Cups
- Special Grippers**
- Gripping Systems
- Clamping Systems
- Mounting Elements
- Vacuum Generators
- Valve Technology
- Switches and Monitoring
- Filters and Connections
- Services
- Contact
- Glossary
- Index of Products

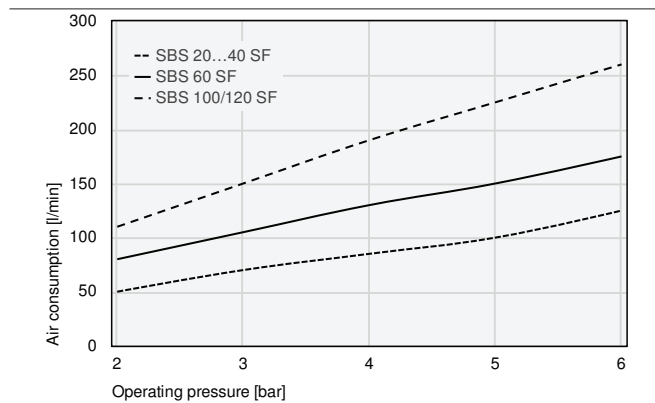

Air consumption

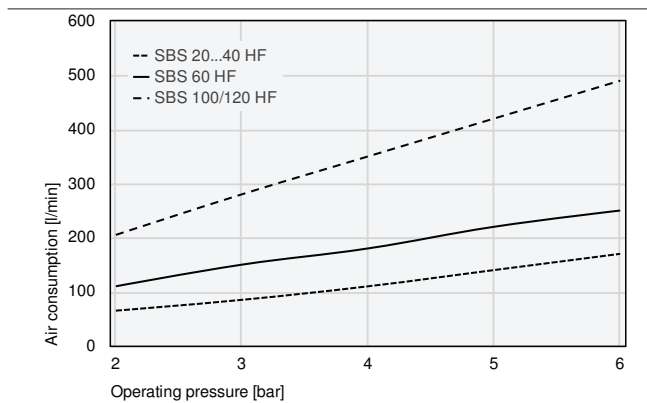

Air consumption

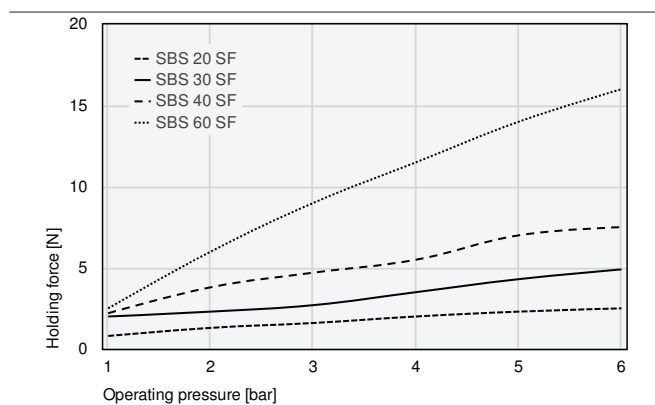

Holding force

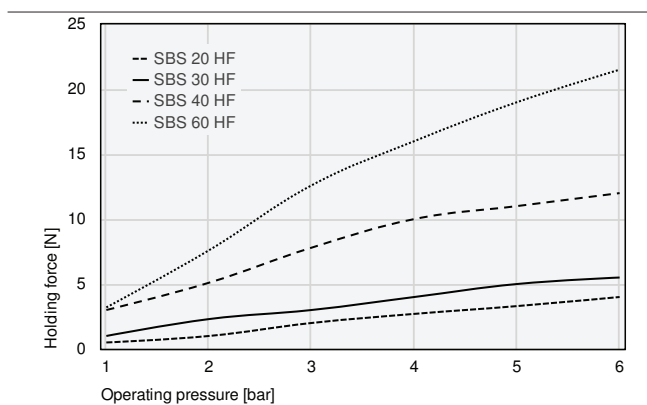

Holding force

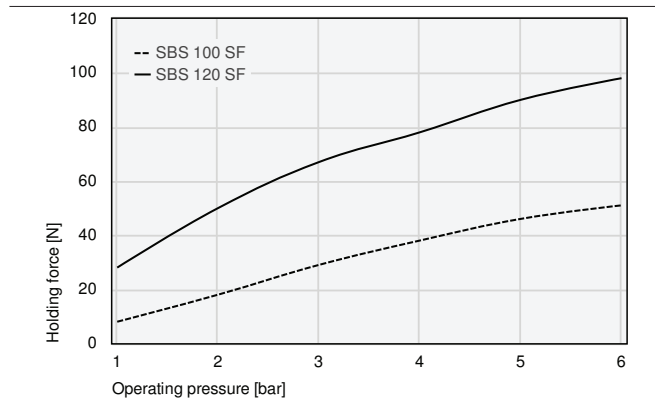

Holding force

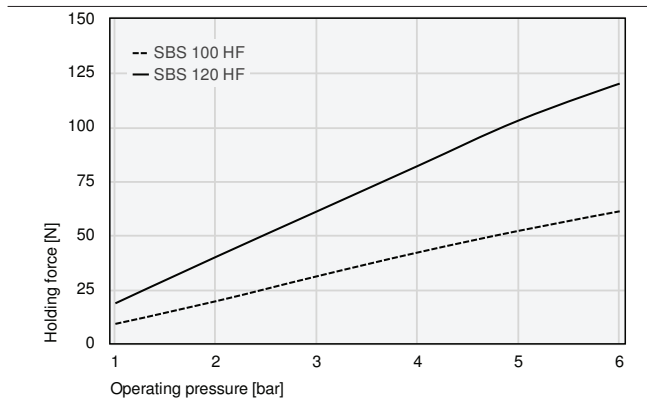

Holding force



# Floating Suction Cups SBS

Diameter (Ø) from 20 mm to 120 mm



## Design Data Floating Suction Cups SBS

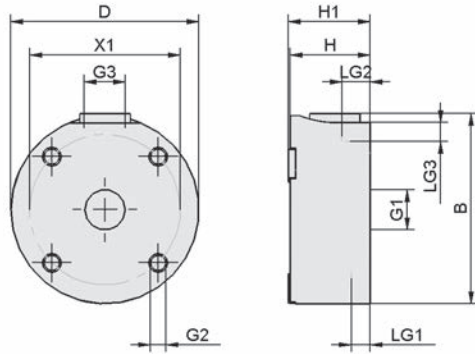

SBS

Type	B [mm]	D [mm]	G1	G2	G3	H [mm]	H1 [mm]	LG1 [mm]	LG2 [mm]	LG3 [mm]	X1 [mm]
SBS 20 HF M5-IG	22.2	20	M5-F	M3-F	M5-F	17	17.5	5	6	6	15
SBS 20 SF M5-IG	22.2	20	M5-F	M3-F	M5-F	17	17.5	5	6	6	15
SBS 30 HF M5-IG	32.0	30	M5-F	M4-F	M5-F	17	17.5	5	6	6	22
SBS 30 SF M5-IG	32.0	30	M5-F	M4-F	M5-F	17	17.5	5	6	6	22
SBS 40 HF G1/8-IG	41.0	40	G1/8"-F	M4-F	G1/8"-F	17	17.5	5	6	6	32
SBS 40 SF G1/8-IG	41.0	40	G1/8"-F	M4-F	G1/8"-F	17	17.5	5	6	6	32
SBS 40 SF G1/8-IG CS	41.0	40	G1/8"-F	M4-F	G1/8"-F	17	17.4	5	6	6	32
SBS 60 HF G1/8-IG	61.6	60	G1/8"-F	M4-F	G1/8"-F	17	17.5	5	6	6	45
SBS 60 SF G1/8-IG	61.6	60	G1/8"-F	M4-F	G1/8"-F	17	17.5	5	6	6	45
SBS 60 SF G1/8-IG CS	61.6	60	G1/8"-F	M4-F	G1/8"-F	17	17.4	5	6	6	45
SBS 100 HF G1/8-IG	101.0	100	G1/8"-F	M4-F	G1/8"-F	17	17.5	5	6	6	75
SBS 100 SF G1/8-IG	101.0	100	G1/8"-F	M4-F	G1/8"-F	17	17.5	5	6	6	75
SBS 120 HF G1/8-IG	121.5	120	G1/8"-F	M4-F	G1/8"-F	17	17.4	5	10	6	105
SBS 120 SF G1/8-IG	121.5	120	G1/8"-F	M4-F	G1/8"-F	17	17.4	5	10	6	105

Schmalz –  
The Company

Vacuum  
Suction Cups

Special  
Grippers

Gripping  
Systems

Clamping  
Systems

Mounting  
Elements

Vacuum  
Generators

Valve  
Technology

Switches and  
Monitoring

Filters and  
Connections

Services

Contact

Glossary

Index of  
Products



# Magnetic Grippers SGM

Suction area (Ø) from 30 mm to 70 mm

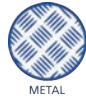

## Suitability for Industry Specific Applications

### Applications

- Magnetic gripper for handling of perforated metal sheets, complex laser-cut workpieces and metal sheets with holes and apertures
- Handling of ferromagnetic workpieces



Magnetic Grippers SGM

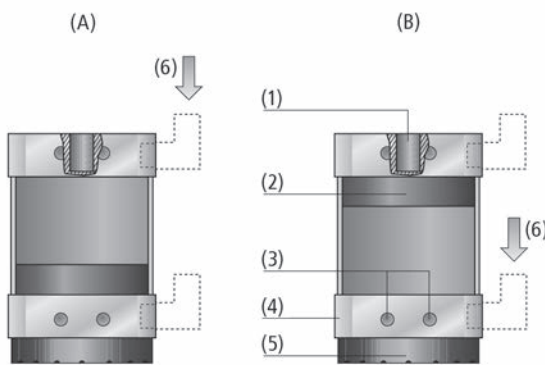

System Design Magnetic Grippers SGM

### Design

- Robust aluminum housing (4) with permanent magnet (2)
- Clip-on, easy to replace friction ring (5)
- Bistable design: the magnet settings "grip" (A) and "deposit" (B) are maintained in event of power failure at the compressed air connection (6)
- Standard connection threads (1) in top cover; mounting threads (3) for holder systems HTS on three sides
- The holder system HTS offers several options for mounting a gripper onto the gripping apparatus; HTS...D version for interlocking and mounting two grippers
- SGM-S with piston control for sensor recognition of piston position of the magnetic gripper, can not be retrofitted

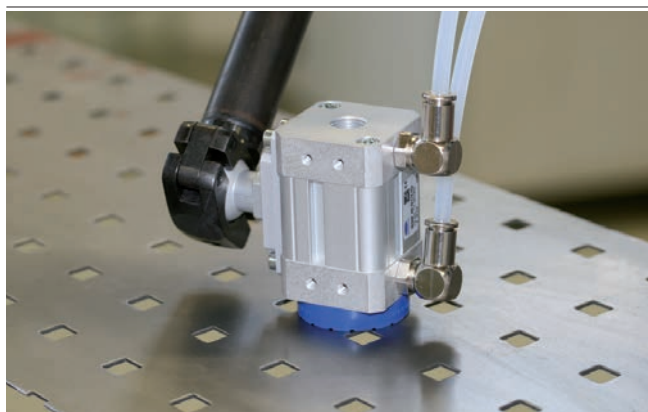

Magnetic grippers SGM being used for handling perforated metal sheets

### Our Highlights...

- Safe gripping by a permanent magnet
- Compact and lightweight design
- Easily replaceable friction ring
- Optional side connection for tooling
- Option to interlock two magnetic grippers (HTS...D)

### Your Benefits...

- No electric power required
- Minimal space requirements, low total weight
- High shear forces can be achieved
- Flexible mounting options
- Optimal for elongated workpieces

Schmalz - The Company  
Vacuum Suction Cups  
Special Grippers  
Gripping Systems  
Clamping Systems  
Mounting Elements  
Vacuum Generators  
Valve Technology  
Switches and Monitoring  
Filters and Connections  
Services  
Contact  
Glossary  
Index of Products



# Magnetic Grippers SGM

Suction area (Ø) from 30 mm to 70 mm



## Designation Code Magnetic Grippers SGM

<b>SGM</b>	-	<b>S</b>	-	<b>30</b>	-	<b>G1/8-IG</b>	-	<b>PNP</b>
1		2		3		4		5

### 1 – Abbreviated designation

Code	Version
SGM	SGM

### 2 – Product addition

Code	Type
S	With piston control
HD	Heavy Duty

### 3 – Diameter

Code	Diameter in mm
30...70	ø 30 to 70

### 4 – Connection

Code	Connection
G1/8-IG	G1/8-IG (IG = female (F))
G1/4-IG	G1/4-IG

### 5 – Switching function sensor

Code	Type
NPN	Switches to minus
PNP	Switches to plus

Magnet gripper SGM is delivered assembled. It is available in three versions:

- Gripper of type SGM - available in various diameters
- Gripper of type SGM-HD - stainless-steel grip surface for robust applications - available in various diameters
- Gripper of type SGM-S - with a piston control by a sensor

Available spare parts: friction ring, proximity switch

Available accessories: holder hystem



## Ordering Data Magnetic Grippers SGM

Type*	Part no.
SGM 30 G1/8-IG	10.01.17.00162
SGM 40 G1/4-IG	10.01.17.00163
SGM 50 G1/4-IG	10.01.17.00164
SGM 70 G1/4-IG	10.01.17.00165
SGM-S 30 G1/8-IG NPN	10.01.17.00216
SGM-S 40 G1/4-IG NPN	10.01.17.00217
SGM-S 50 G1/4-IG NPN	10.01.17.00218
SGM-S 70 G1/4-IG NPN	10.01.17.00219
SGM-S 30 G1/8-IG PNP	10.01.17.00200
SGM-S 40 G1/4-IG PNP	10.01.17.00201
SGM-S 50 G1/4-IG PNP	10.01.17.00202
SGM-S 70 G1/4-IG PNP	10.01.17.00203
SGM-HD 30 G1/8-IG	10.01.17.00184
SGM-HD 40 G1/4-IG	10.01.17.00185
SGM-HD 50 G1/4-IG	10.01.17.00273
SGM-HD 70 G1/4-IG	10.01.17.00272

\*Suitable screw in push fittings can be found under "Screw in push fittings" in section "Filters and Connections"

# Magnetic Grippers SGM

Suction area (Ø) from 30 mm to 70 mm



## Ordering Data Spare Parts Magnetic Grippers SGM

Type	Friction ring	Proximity switch NPN	Proximity switch PNP
SGM 30 G1/8-IG	10.01.17.00136	-	-
SGM 40 G1/4-IG	10.01.17.00137	-	-
SGM 50 G1/4-IG	10.01.17.00138	-	-
SGM 70 G1/4-IG	10.01.17.00139	-	-
SGM-S 30 G1/8-IG NPN	10.01.17.00136	10.01.17.00215	-
SGM-S 40 G1/4-IG NPN	10.01.17.00137	10.01.17.00215	-
SGM-S 50 G1/4-IG NPN	10.01.17.00138	10.01.17.00215	-
SGM-S 70 G1/4-IG NPN	10.01.17.00139	10.01.17.00215	-
SGM-S 30 G1/8-IG PNP	10.01.17.00136	-	10.01.17.00199
SGM-S 40 G1/4-IG PNP	10.01.17.00137	-	10.01.17.00199
SGM-S 50 G1/4-IG PNP	10.01.17.00138	-	10.01.17.00199
SGM-S 70 G1/4-IG PNP	10.01.17.00139	-	10.01.17.00199
SGM-HD 30 G1/8-IG	10.01.17.00136	-	-
SGM-HD 40 G1/4-IG	10.01.17.00137	-	-
SGM-HD 50 G1/4-IG	10.01.17.00138	-	-
SGM-HD 70 G1/4-IG	10.01.17.00139	-	-



## Ordering Data Accessories Magnetic Grippers SGM

Type*	Holder system HTS-A2	Holder system HTS-A3
SGM 30	10.01.17.00169	10.01.17.00170
SGM 40	10.01.17.00169	10.01.17.00170
SGM 50	10.01.17.00172	10.01.17.00173
SGM 70	10.01.17.00172	10.01.17.00173

\*Complete with mounting screws

Type*	Holder system HTS-A2 D	Holder system HTS-A3 D
SGM 30	10.01.17.00175	10.01.17.00176
SGM 40	10.01.17.00175	10.01.17.00176
SGM 50	10.01.17.00178	10.01.17.00179
SGM 70	10.01.17.00178	10.01.17.00179

\*Complete with mounting screws



## Technical Data Magnetic Grippers SGM

Type	Holding force max. friction ring [N]*	Remaining force [N]	Pressure range (operating pressure) [bar]	Installation position	Control valve	Operating temperature [°C]	Weight [g]
SGM 30 G1/8-IG	35	0.3	3.5 ... 6.0	Any	Bistable	5 ... 70	130
SGM 40 G1/4-IG	100	0.3	3.5 ... 6.0	Any	Bistable	5 ... 70	240
SGM 50 G1/4-IG	180	0.3	3.5 ... 6.0	Any	Bistable	5 ... 70	440
SGM 70 G1/4-IG	290	0.3	3.5 ... 6.0	Any	Bistable	5 ... 70	715
SGM-S 30 G1/8-IG NPN	35	0.3	3.5 ... 6.0	Any	Bistable	5 ... 70	145
SGM-S 40 G1/4-IG NPN	100	0.3	3.5 ... 6.0	Any	Bistable	5 ... 70	255
SGM-S 50 G1/4-IG NPN	180	0.3	3.5 ... 6.0	Any	Bistable	5 ... 70	445
SGM-S 70 G1/4-IG NPN	290	0.3	3.5 ... 6.0	Any	Bistable	5 ... 70	730
SGM-S 30 G1/8-IG PNP	35	0.3	3.5 ... 6.0	Any	Bistable	5 ... 70	145
SGM-S 40 G1/4-IG PNP	100	0.3	3.5 ... 6.0	Any	Bistable	5 ... 70	255

# Magnetic Grippers SGM

Suction area (Ø) from 30 mm to 70 mm

## Technical Data Magnetic Grippers SGM

Type	Holding force max. friction ring [N]*	Remaining force [N]	Pressure range (operating pressure) [bar]	Installation position	Control valve	Operating temperature [°C]	Weight [g]
SGM-S 50 G1/4-IG PNP	180	0.3	3.5 ... 6.0	Any	Bistable	5 ... 70	445
SGM-S 70 G1/4-IG PNP	290	0.3	3.5 ... 6.0	Any	Bistable	5 ... 70	730
SGM-HD 30 G1/8-IG	35	0.3	3.5 ... 6.0	Any	Bistable	5 ... 70	191
SGM-HD 40 G1/4-IG	100	0.3	3.5 ... 6.0	Any	Bistable	5 ... 70	342
SGM-HD 50 G1/4-IG	180	0.3	3.5 ... 6.0	Any	Bistable	5 ... 70	594
SGM-HD 70 G1/4-IG	290	0.3	3.5 ... 6.0	Any	Bistable	5 ... 70	975

\*The value given is a static value with no safety factor; based on a plate with a thickness of 2 mm. For system configurations with magnetic grippers SGM, a safety factor of S = 3 must be applied.

## Design Data Magnetic Grippers SGM

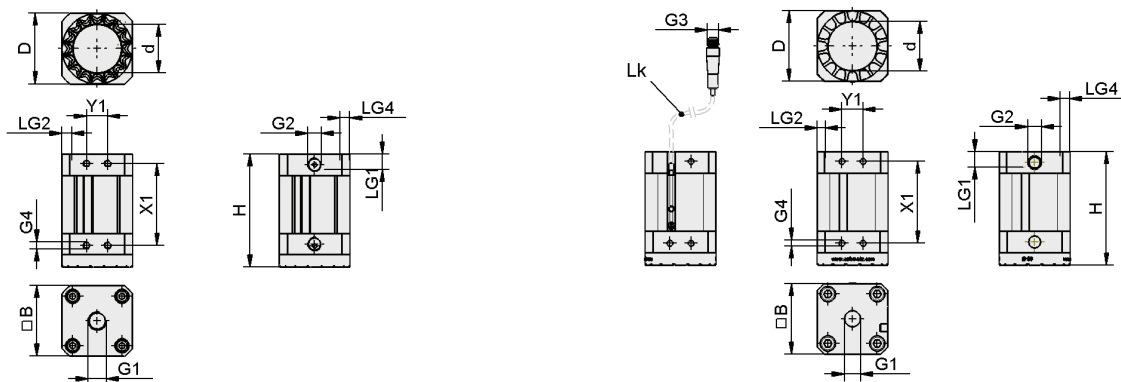

SGM, SGM-HD

SGM-S

Type	B [mm]*	d [mm]	D [mm]	G1	G2	G3	G4	H [mm]	LG1 [mm]	LG2 [mm]	LG4 [mm]	Lk [mm]	X1 [mm]	Y1 [mm]
SGM 30 G1/8-IG	30.0	16.5	29.5	G1/8"-F	G1/8"-F	-	M4-F	70.2	7	6	5	-	46	12
SGM 40 G1/4-IG	40.6	26.0	40.0	G1/4"-F	G1/8"-F	-	M4-F	70.2	11	6	7	-	46	12
SGM 50 G1/4-IG	50.6	35.0	50.0	G1/4"-F	G1/8"-F	-	M5-F	80.2	11	6	7	-	58	15
SGM 70 G1/4-IG	68.7	51.0	68.0	G1/4"-F	G1/8"-F	-	M5-F	80.2	11	6	8	-	58	15
SGM-S 30 G1/8-IG NPN	30.0	16.5	29.5	G1/8"-F	G1/8"-F	M12x1-M	M4-F	70.2	7	6	5	300	46	12
SGM-S 40 G1/4-IG NPN	40.6	26.0	40.0	G1/4"-F	G1/8"-F	M12x1-M	M4-F	70.2	11	6	7	300	46	12
SGM-S 50 G1/4-IG NPN	50.6	35.0	50.0	G1/4"-F	G1/8"-F	M12x1-M	M5-F	80.2	11	6	7	300	58	15
SGM-S 70 G1/4-IG NPN	68.7	51.0	68.0	G1/4"-F	G1/8"-F	M12x1-M	M5-F	80.2	11	6	8	300	58	15
SGM-S 30 G1/8-IG PNP	30.0	16.5	29.5	G1/8"-F	G1/8"-F	M12x1-M	M4-F	70.2	7	6	5	300	46	12
SGM-S 40 G1/4-IG PNP	40.6	26.0	40.0	G1/4"-F	G1/8"-F	M12x1-M	M4-F	70.2	11	6	7	300	46	12
SGM-S 50 G1/4-IG PNP	50.6	35.0	50.0	G1/4"-F	G1/8"-F	M12x1-M	M5-F	80.2	11	6	7	300	58	15
SGM-S 70 G1/4-IG PNP	68.7	51.0	68.0	G1/4"-F	G1/8"-F	M12x1-M	M5-F	80.2	11	6	8	300	58	15
SGM-HD 30 G1/8-IG	30.0	16.5	29.5	G1/8"-F	G1/8"-F	-	M4-F	61.4	7	6	5	-	46	12
SGM-HD 40 G1/4-IG	40.6	26.0	40.0	G1/4"-F	G1/8"-F	-	M4-F	61.4	11	6	7	-	46	12
SGM-HD 50 G1/4-IG	50.6	35.0	50.0	G1/4"-F	G1/8"-F	-	M5-F	71.4	11	6	7	-	58	15
SGM-HD 70 G1/4-IG	68.7	51.0	68.0	G1/4"-F	G1/8"-F	-	M5-F	71.4	11	6	8	-	58	15

\*Contact surface of the grippers (round) corresponds to dimension B

# Magnetic Grippers SGM-HP/-HT

Suction area (Ø) from 20 mm to 50 mm

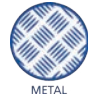

## Suitability for Industry Specific Applications

### Applications

- Magnetic grippers with very high holding forces for handling perforated plates, workpieces with complex laser-cut patterns, sheet metal containing drill holes and apertures, and similar objects
- Handling of ferromagnetic workpieces
- Can be used without friction ring for higher holding forces
- HT version for high-temperature applications (e.g. hot forming processes)



Magnetic Grippers SGM-HP/-HT

### Design

- Sturdy aluminum housing (4) with permanent magnet (2)
- Friction ring (5) for high lateral forces in dynamic processes
- Bistable design: the magnet settings "grip" (A) and "deposit" (B) are maintained in event of power failure at the compressed air connection (6)
- Mounting thread at the head end (1) and on two sides of the gripper for holder (3)
- Option to mount using Schmalz holder system HTS
- Optional lifting elements allow for optimal handling of round or non-flat workpieces

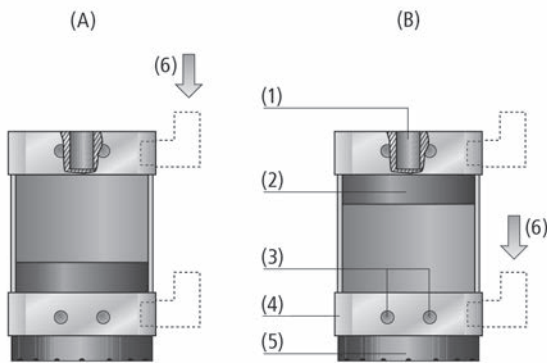

System Design Magnetic Grippers SGM-HP/-HT



Magnetic gripper SGM-HP handling sheet metal

### Our Highlights...

- Secure handling with a permanent magnet
- Compact and lightweight design
- Easily replaceable friction ring
- Option to connect tooling on the sides
- Low compressed air level needed for control

### Your Benefits...

- No voltage source required
- Minimal space required, low weight
- Absorption of high shear forces
- Flexible mounting options
- Reliable operation even with fluctuating compressed air supply

The magnetic gripper SGM-HP/-HT is not available in the Netherlands.

Schmalz – The Company  
Vacuum Suction Cups  
Special Grippers  
Gripping Systems  
Clamping Systems  
Mounting Elements  
Vacuum Generators  
Valve Technology  
Switches and Monitoring  
Filters and Connections  
Services  
Contact  
Glossary  
Index of Products

# Magnetic Grippers SGM-HP/-HT

Suction area (Ø) from 20 mm to 50 mm



## Designation Code Magnetic Grippers SGM-HP/-HT

<b>SGM</b>	-	<b>HP</b>	-	<b>40</b>	-	<b>G1/4-IG</b>
1		2		3		4

### 1 – Abbreviated designation

Code	Version
SGM	SGM

### 2 – Product range supplement

Code	Type
HP	High performance
HT	High temperature

### 3 – Diameter

Code	Diameter in mm
20...50	Ø 20 to 50

### 4 – Connection

Code	Mechanical connection
G1/4-IG	G1/4-IG (IG = female (F))
G1/8-IG	G1/8-IG

Magnet gripper SGM-HP/-HT is delivered assembled. The assembly consists of:

- Gripper SGM-HP with friction ring PU - available in various diameters
- Gripper SGM-HT with steel gripping surface for robust applications - available in various diameters
- Friction ring made of the material PU (only for SGM-HP)
- Optional friction ring HT2 for high-temperature applications (only for SGM-HT)
- Optional proximity switch (only for SGM-HP)

Available spare parts: friction ring PU for SGM-HP

Available accessories: proximity switch, holder system, mounting element (ADP), friction ring HT2, protection element



## Ordering Data Magnetic Grippers SGM-HP/-HT

Type*	Part no.
SGM-HP 20 G1/8-IG	10.01.17.00424
SGM-HP 30 G1/8-IG	10.01.17.00316
SGM-HP 40 G1/4-IG	10.01.17.00304
SGM-HP 50 G1/4-IG	10.01.17.00282
SGM-HT-HP 30 G1/8-IG	10.01.17.00397
SGM-HT-HP 40 G1/4-IG	10.01.17.00403
SGM-HT-HP 50 G1/4-IG	10.01.17.00402

\*Note: See "Plug-in screw unions" in section "Filters and connection" for matching plug-in screw unions.



## Ordering Data Spare Parts Magnetic Grippers SGM-HP/-HT

Type	Spare Parts		Part no.
SGM-HP 20 G1/8-IG	Friction ring	REIB-RING SGM 20 PU-55	10.01.17.00418
SGM-HP 30 G1/8-IG	Friction ring	REIB-RING SGM 30 PU-55	10.01.17.00385
SGM-HP 40 G1/4-IG	Friction ring	REIB-RING SGM 40 PU-55	10.01.17.00373
SGM-HP 50 G1/4-IG	Friction ring	REIB-RING SGM 50 PU-55	10.01.17.00381
SGM-HT-HP 30 G1/8-IG	-	-	-
SGM-HT-HP 40 G1/4-IG	-	-	-
SGM-HT-HP 50 G1/4-IG	-	-	-

The magnetic gripper SGM-HP/-HT is not available in the Netherlands.



# Magnetic Grippers SGM-HP/-HT

Suction area (Ø) from 20 mm to 50 mm



## Ordering Data Accessories Magnetic Grippers SGM-HP/-HT

Type	Holder system A2	Holder system A3
SGM-HP 20 G1/8-IG	10.01.17.00414	10.01.17.00413
SGM-HP 30 G1/8-IG	10.01.17.00416	10.01.17.00378
SGM-HP 40 G1/4-IG	10.01.17.00416	10.01.17.00378
SGM-HP 50 G1/4-IG	10.01.17.00417	10.01.17.00383
SGM-HT-HP 30 G1/8-IG	10.01.17.00416	10.01.17.00378
SGM-HT-HP 40 G1/4-IG	10.01.17.00416	10.01.17.00378
SGM-HT-HP 50 G1/4-IG	10.01.17.00417	10.01.17.00383

Type	Mounting element ADP-E...TRI	Mounting element ADP-E...UNI
SGM-HP 20 G1/8-IG	10.01.17.00419	10.01.17.00420
SGM-HP 30 G1/8-IG	10.01.17.00421	10.01.17.00423
SGM-HP 40 G1/4-IG	10.01.17.00421	10.01.17.00423
SGM-HP 50 G1/4-IG	10.01.17.00422	10.01.17.00415
SGM-HT-HP 30 G1/8-IG	10.01.17.00421	10.01.17.00423
SGM-HT-HP 40 G1/4-IG	10.01.17.00421	10.01.17.00423
SGM-HT-HP 50 G1/4-IG	10.01.17.00422	10.01.17.00415

Type	Proximity switch PNP	Proximity switch NPN	Friction ring
SGM-HP 20 G1/8-IG	10.01.17.00199	10.01.17.00215	-
SGM-HP 30 G1/8-IG	10.01.17.00199	10.01.17.00215	-
SGM-HP 40 G1/4-IG	10.01.17.00199	10.01.17.00215	-
SGM-HP 50 G1/4-IG	10.01.17.00199	10.01.17.00215	-
SGM-HT-HP 30 G1/8-IG	-	-	10.01.17.00410
SGM-HT-HP 40 G1/4-IG	-	-	10.01.17.00411
SGM-HT-HP 50 G1/4-IG	-	-	10.01.17.00412

Type	Accessories	Part no.
SGM-HP/-HT 30	Protection element	SCHUTZ SGM-30 ST
SGM-HP/-HT 40	Protection element	SCHUTZ SGM-40 ST
SGM-HP/-HT 50	Protection element	SCHUTZ SGM-50 ST



## Technical Data Magnetic Grippers SGM-HP/-HT

Type	Holding force max. without friction ring [N]*	Holding force max. friction ring [N]	Sheet thickness opt f. holding force max. [mm]**	Holding force 2mm-sheet without friction ring [N]	Holding force 2mm-sheet friction ring [N]	Remaining force [N]
SGM-HP 20 G1/8-IG	28	19	1	25	16	0.3
SGM-HP 30 G1/8-IG	130	90	2	130	90	0.3
SGM-HP 40 G1/4-IG	320	235	4	290	210	0.3
SGM-HP 50 G1/4-IG	560	385	6	415	290	0.3
SGM-HT-HP 30 G1/8-IG	120	80	2	120	80	0.3
SGM-HT-HP 40 G1/4-IG	290	230	4	260	200	0.3
SGM-HT-HP 50 G1/4-IG	520	330	6	370	270	0.3

\*Note: The specified holding forces are static specifications under ideal conditions (primarily depending on material and surface finish). For system designs, a safety factor (S) of 3 should be applied.

\*\*Holding forces at 20° C can be used for workpiece temperatures up to 350° C (depending on process conditions), temperature can reduce holding forces by up to 30 %.



# Magnetic Grippers SGM-HP/-HT

Suction area (Ø) from 20 mm to 50 mm



## Technical Data Magnetic Grippers SGM-HP/-HT

Type	Pressure range (operating pressure) [bar]	Installation position	Control valve	Operating temperature [°C]	Weight [g]
SGM-HP 20 G1/8-IG	2.5 ... 6.0	Any	Bistable	5 ... 70	81
SGM-HP 30 G1/8-IG	2.5 ... 6.0	Any	Bistable	5 ... 70	215
SGM-HP 40 G1/4-IG	2.5 ... 6.0	Any	Bistable	5 ... 70	415
SGM-HP 50 G1/4-IG	2.5 ... 6.0	Any	Bistable	5 ... 70	770
SGM-HT-HP 30 G1/8-IG	2.5 ... 6.0	Any	Bistable	5 ... 150	215
SGM-HT-HP 40 G1/4-IG	2.5 ... 6.0	Any	Bistable	5 ... 150	415
SGM-HT-HP 50 G1/4-IG	2.5 ... 6.0	Any	Bistable	5 ... 150	770



## Design Data Magnetic Grippers SGM-HP/-HT

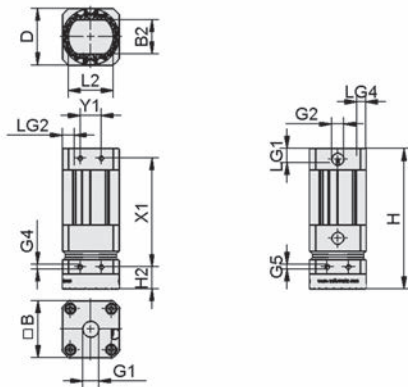

SGM-HP 20 - 50

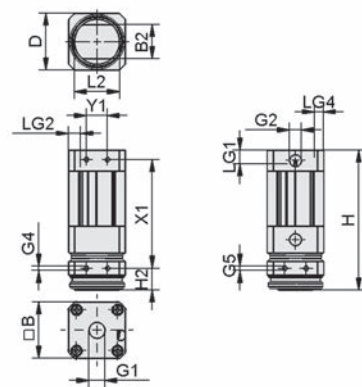

SGM-HT-HP 30 - 50

Type	B [mm]	B2 [mm]*	D [mm]**	G1	G2	G4	G5	H [mm]	H2 [mm]	L2 [mm]	LG1 [mm]	LG2 [mm]	LG4 [mm]	X1 [mm]	Y1 [mm]
SGM-HP 20 G1/8-IG	20	9.1	20.0	G1/8"-F	M5-F	M3-F	M3-F	78.2	13.2	12.0	6	5.5	4.0	55.0	6.5
SGM-HP 30 G1/8-IG	30	15.0	30.0	G1/8"-F	G1/8"-F	M4-F	M4-F	99.4	15.7	20.5	6	7.0	5.0	74.0	12.0
SGM-HP 40 G1/4-IG	40	24.2	40.0	G1/4"-F	G1/8"-F	M4-F	M4-F	99.4	15.7	32.0	9	6.0	5.0	74.0	12.0
SGM-HP 50 G1/4-IG	50	31.2	50.0	G1/4"-F	G1/8"-F	M5-F	M4-F	123.4	15.7	41.5	10	6.0	6.5	100.0	15.0
SGM-HT-HP 30 G1/8-IG	30	15.0	26.9	G1/8"-F	G1/8"-F	M4-F	M4-F	99.2	15.5	20.5	6	7.0	5.0	74.0	12.0
SGM-HT-HP 40 G1/4-IG	40	24.2	38.4	G1/4"-F	G1/8"-F	M4-F	M4-F	99.2	15.5	32.0	9	6.0	5.0	74.0	12.0
SGM-HT-HP 50 G1/4-IG	50	31.2	48.4	G1/4"-F	G1/8"-F	M5-F	M4-F	123.2	15.5	41.5	10	6.0	6.5	100.0	15.0

\*Gripper contact surface without friction ring (stadium-shaped) is approx. dimension D x B2; with friction ring (round), dimension D  
 \*\*Gripper contact surface (round) is dimension D

# Electric Needle Grippers SNGi-AE

Needle stroke max. 3 mm to max. 20 mm (variable)



## Suitability for Industry Specific Applications

### Applications

- Electric needle gripper for handling non-rigid and highly porous materials (primary textiles)
- Handling materials that are difficult to grip using vacuum such as textiles, fleece, filter materials, insulation and foam materials, and much more
- Flexible handling of materials with changing stacking height due to free selectable stroke adjustment



Electric Needle Grippers SNGi-AE

### Design

- Electrically driven gripper
- High-strength housing with lightweight design (1)
- Three sizes with needle strokes of max. 3 mm, 10 mm or 20 mm
- Ten needles (4) with diameters of 0.8 mm or 1.2 mm (depending on the model)
- Insertion angle of 30° or 45° (depending on the model)
- LED status display (2); IO-Link interface with M12 plug connection, 5-pin (3)

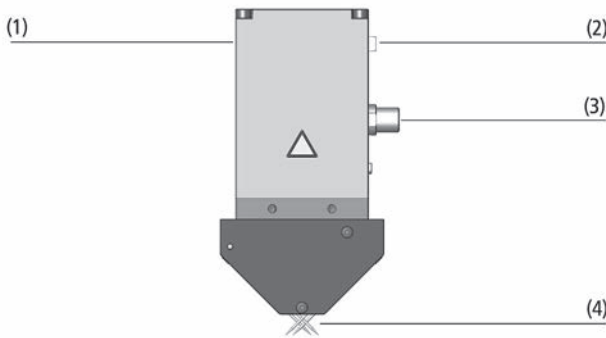

System Design Electric Needle Grippers SNGi-AE



Electric needle grippers SNGi-AE for handling composite textiles

### Our Highlights...

- Intersecting needles and small gripping area
- Needle stroke adjustable using definable process profiles; continuous stroke monitoring
- Stroke can be adapted for each cycle; unlimited number of stroke sequences possible
- Blow off function for fast and exact release of the workpiece

### Your Benefits...

- Safe handling, even of small and very unstable workpieces
- Individual adaptation to different workpiece geometries; compreh. process control available
- Allows handling of single layers and complete stacks with just one gripper
- High level of process reliability; short cycle times

- Schmalz – The Company
- Vacuum Suction Cups
- Special Grippers
- Gripping Systems
- Clamping Systems
- Mounting Elements
- Vacuum Generators
- Valve Technology
- Switches and Monitoring
- Filters and Connections
- Services
- Contact
- Glossary
- Index of Products



# Electric Needle Grippers SNGi-AE

Needle stroke max. 3 mm to max. 20 mm (variable)

## Designation Code Electric Needle Grippers SNGi-AE

<b>SNGi-AE</b>	-	<b>10</b>	-	<b>0.8</b>	-	<b>V</b>	-	<b>3</b>	-	<b>IOL</b>
<b>1</b>		<b>2</b>		<b>3</b>		<b>4</b>		<b>5</b>		<b>6</b>

### 1 – Abbreviated designation

Code	Version
SNGi-AE	Crossed needles

### 2 – Number of needles

Code	Number
10	10

### 3 – Needle diameter

Code	Diameter in mm
0.8...1.2	ø 0.8 and 1.2

### 4 – Product addition

Code	Type
V	Variable needle stroke

### 5 – Needle stroke

Code	Stroke in mm
3...20	3 to 20

### 6 – Product addition

Code	Type
IOL	IO-Link compatible

Needle gripper SNGi-AE is delivered assembled. The product consists of:

- Gripper of type SNGi-AE – available with various needle diameters and strokes

Available spare parts: needle modules, maintenance cover

Available accessories: mounting plate, holder system, connection cable, connection distributor

## Ordering Data Electric Needle Grippers SNGi-AE

Type	Part no.
SNGi-AE 10 0.8 V 3 IOL	10.01.29.00390
SNGi-AE 10 0.8 V 10 IOL	10.01.29.00392
SNGi-AE 10 1.2 V 3 IOL	10.01.29.00394
SNGi-AE 10 1.2 V 10 IOL	10.01.29.00396
SNGi-AE 10 1.2 V 20 IOL	10.01.29.00393

## Ordering Data Spare Parts Electric Needle Grippers SNGi-AE

Type	Spare Parts*	Part no.
SNGi-AE 10 0.8 V 3 IOL	Needle module	ERS-SET SNG-AP/AE 10 0.8 3
SNGi-AE 10 0.8 V 10 IOL	Needle module	ERS-SET SNG-AP/AE 10 0.8 10
SNGi-AE 10 1.2 V 3 IOL	Needle module	ERS-SET SNG-AP/AE 10 1.2 3
SNGi-AE 10 1.2 V 10 IOL	Needle module	ERS-SET SNG-AP/AE 10 1.2 10
SNGi-AE 10 1.2 V 20 IOL	Needle module	ERS-SET SNG-AP/AE 10 1.2 20

\*Set of two needle housings with needles

Type	Spare Parts*	Part no.
SNGi-AE 10 0.8 V 3 IOL	Maintenance cover	ERS-SET SNG-AP/AE 3
SNGi-AE 10 0.8 V 10 IOL	Maintenance cover	ERS-SET SNG-AP/AE 10
SNGi-AE 10 1.2 V 3 IOL	Maintenance cover	ERS-SET SNG-AP/AE 3
SNGi-AE 10 1.2 V 10 IOL	Maintenance cover	ERS-SET SNG-AP/AE 10
SNGi-AE 10 1.2 V 20 IOL	Maintenance cover	ERS-SET SNG-AP/AE 20

\*Set of 2 coverages

# Electric Needle Grippers SNGi-AE

Needle stroke max. 3 mm to max. 20 mm (variable)



## Ordering Data Accessories Electric Needle Grippers SNGi-AE

Type		Part no.
Holder system HTS-A2	HTS-A2 AP SNG	10.01.29.00402
Holder system HTS-A3	HTS-A3 AP SNG AP/AE	10.01.29.00322
Mounting plate	BEF-PL 38x15x11.5 G1/4-IG SNG	10.01.29.00403
Connection distributor 1x M12, 5 pol, 2x M12, 4 pol	ASV IO-L-A 2xS-M12-4	10.02.02.04336
Connection cable, M12 5-pole, M12 5-pole, 1 m, PUR, straight	ASK B-M12-5 1000 S-M12-5	21.04.05.00158
Connection cable, M12 5-pole, M12 5-pole, 2 m, PUR, straight	ASK B-M12-5 2000 S-M12-5	21.04.05.00211
Connection cable, M12 5-pole, 5 m, PUR, straight	ASK B-M12-5 5000	21.04.05.00080



## Technical Data Electric Needle Grippers SNGi-AE

Type	Number of needles	Needle diameter [mm]	Needle stroke Z (NA) [mm]*	Operating temperature [°C]	Electrical connection	Weight [g]	Protection type IP	Voltage	Current consumption [mA]**
SNGi-AE 10 0.8 V 3 IOL	10	0.8	3	5 ... 50	Male connect M12, 5 pol	500	53	24V - DC V	900
SNGi-AE 10 0.8 V 10 IOL	10	0.8	10	5 ... 50	Male connect M12, 5 pol	515	53	24V - DC V	900
SNGi-AE 10 1.2 V 3 IOL	10	1.2	3	5 ... 50	Male connect M12, 5 pol	500	53	24V - DC V	900
SNGi-AE 10 1.2 V 10 IOL	10	1.2	10	5 ... 50	Male connect M12, 5 pol	515	53	24V - DC V	900
SNGi-AE 10 1.2 V 20 IOL	10	1.2	20	5 ... 50	Male connect M12, 5 pol	600	53	24V - DC V	900

\*Needle speed approx. 8 mm/s per stroke

\*\*Max. power consumption during normal operation 600 mA



## Design Data Electric Needle Grippers SNGi-AE

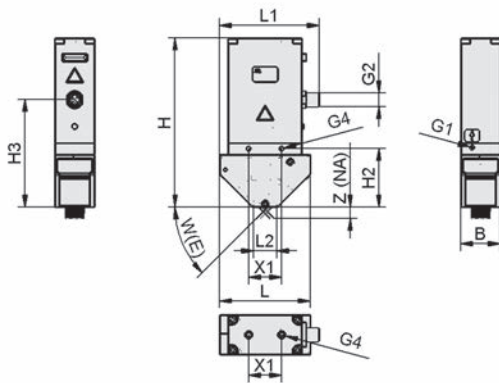

SNGi-AE

Type	B [mm]	G1	G2	G4	H [mm]	H2 [mm]	H3 [mm]	L [mm]	L1 [mm]	L2 [mm]	W(E) [°]	X1 [mm]	Z(NA) [mm]
SNGi-AE 10 0.8 V 3 IOL	35	M5-F	M12x1-M	M5-F	140.0	40.2	83.2	65	80.0	28	30	29	3
SNGi-AE 10 0.8 V 10 IOL	35	M5-F	M12x1-M	M5-F	151.5	51.5	94.5	80	87.5	22	45	29	10
SNGi-AE 10 1.2 V 3 IOL	35	M5-F	M12x1-M	M5-F	140.0	40.2	83.2	65	80.0	28	30	29	3
SNGi-AE 10 1.2 V 10 IOL	35	M5-F	M12x1-M	M5-F	151.5	51.5	94.5	80	87.5	22	45	29	10
SNGi-AE 10 1.2 V 20 IOL	35	M5-F	M12x1-M	M5-F	178.0	78.2	121.0	120	107.5	22	45	29	20



# Needle Grippers SNG-AP

Needle stroke max. 3 mm to max. 20 mm (variable)



Needle Grippers SNG-AP

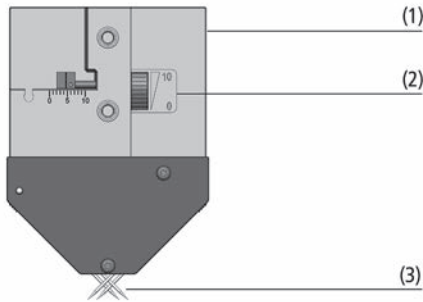

System Design Needle Grippers SNG-AP

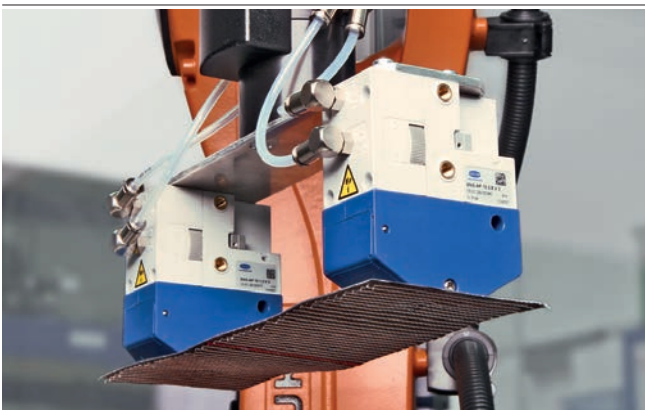

Needle grippers SNG-AP being used for handling composite textiles

## Suitability for Industry Specific Applications

### Applications

- Needle gripper for handling non-rigid and highly porous materials (primarily textiles)
- Handling materials that are difficult to grip using vacuum such as composite textiles, fleece, filter materials, insulation and foam materials etc.
- Flexible handling of materials with changing stacking height due to free selectable stroke adjustment

### Design

- Driven by double-acting pneumatic cylinders
- High-strength housing with lightweight design (1)
- Three sizes with needle strokes of max. 3 mm, 10 mm or 20 mm
- Adjustment wheel (2) with scale for continuous, simultaneous stroke adjustment
- Ten needles (3) with diameters of 0.8 mm or 1.2 mm (depending on the model)
- Insertion angle of 30° or 45° (depending on the model)

### Our Highlights...

- Intersecting needles and small gripping area
- Blow off function for fast and reliable load release
- Tool-free simultaneous needle stroke adjustment up to a maximum of 20 mm
- Low weight and double-acting pneumatic cylinders

### Your Benefits...

- Safe handling, even of small and very unstable workpieces
- High level of process reliability and exact positioning; short cycle times
- Individual adaptation to the workpiece geometry; fast start of operations and short set-up time
- High acceleration for minimized cycle times



# Needle Grippers SNG-AP

Needle stroke max. 3 mm to max. 20 mm (variable)



## Designation Code Needle Grippers SNG-AP

<b>SNG-AP</b>	-	<b>10</b>	-	<b>0.8</b>	-	<b>V</b>	-	<b>3</b>
<b>1</b>		<b>2</b>		<b>3</b>		<b>4</b>		<b>5</b>

### 1 – Abbreviated designation

Code	Version
SNG-AP	Crossed needles

### 2 – Number of needles

Code	Number
10	10

### 3 – Needle diameter

Code	Diameter in mm
0.8...1.2	ø 0.8 and 1.2

### 4 – Product addition

Code	Type
V	Variable needle stroke

### 5 – Needle stroke

Code	Stroke in mm
3...20	3 to 20

Needle gripper SNG-AP is delivered assembled. The product consists of:

- Gripper of type SNG-AP - available with various needle diameters and strokes

Available spare parts: needle modules, maintenance cover

Available accessories: mounting plate, holder system, add-on kit sensor (retrofitting kit), screw in push fittings (plug union, elbow)



## Ordering Data Needle Grippers SNG-AP

Type	Part no.
SNG-AP 10 0.8 V 3	10.01.29.00340
SNG-AP 10 0.8 V 10	10.01.29.00361
SNG-AP 10 1.2 V 3	10.01.29.00377
SNG-AP 10 1.2 V 10	10.01.29.00381
SNG-AP 10 1.2 V 20	10.01.29.00362



## Ordering Data Spare Parts Needle Grippers SNG-AP

Type	Spare Parts*	Part no.
SNG-AP 10 0.8 V 3	Needle module	ERS-SET SNG-AP/AE 10 0.8 3 10.01.29.00405
SNG-AP 10 0.8 V 10	Needle module	ERS-SET SNG-AP/AE 10 0.8 10 10.01.29.00407
SNG-AP 10 1.2 V 3	Needle module	ERS-SET SNG-AP/AE 10 1.2 3 10.01.29.00406
SNG-AP 10 1.2 V 10	Needle module	ERS-SET SNG-AP/AE 10 1.2 10 10.01.29.00408
SNG-AP 10 1.2 V 20	Needle module	ERS-SET SNG-AP/AE 10 1.2 20 10.01.29.00409

\*Set of two needle housings with needles

Type	Spare Parts*	Part no.
SNG-AP 10 0.8 V 3	Maintenance cover	ERS-SET SNG-AP/AE 3 10.01.29.00419
SNG-AP 10 0.8 V 10	Maintenance cover	ERS-SET SNG-AP/AE 10 10.01.29.00420
SNG-AP 10 1.2 V 3	Maintenance cover	ERS-SET SNG-AP/AE 3 10.01.29.00419
SNG-AP 10 1.2 V 10	Maintenance cover	ERS-SET SNG-AP/AE 10 10.01.29.00420
SNG-AP 10 1.2 V 20	Maintenance cover	ERS-SET SNG-AP/AE 20 10.01.29.00421

\*Set of 2 coverages

# Needle Grippers SNG-AP

Needle stroke max. 3 mm to max. 20 mm (variable)



## Ordering Data Accessories Needle Grippers SNG-AP

Type	Part no.
Mounting plate	BEF-PL 38x15x11.5 G1/4-IG SNG
Holder system	HTS-A2 AP SNG
Holder system	HTS-A3 AP SNG AP/AE
Retrofitting kit	SET SNG AP-Sensor
Plug union, elbow	STV-W M5-AG 6



## Technical Data Needle Grippers SNG-AP

Type	Number of needles	Needle diameter [mm]	Add. function	Pressure range (operating pressure) [bar]	Operating temperature [°C]	Installation position	Weight [g]
SNG-AP 10 0.8 V 3	10	0.8	Variable stroke	3.0 ... 6.0	5 ... 75	Any	190
SNG-AP 10 0.8 V 10	10	0.8	Variable stroke	3.0 ... 6.0	5 ... 75	Any	225
SNG-AP 10 1.2 V 3	10	1.2	Variable stroke	3.0 ... 6.0	5 ... 75	Any	190
SNG-AP 10 1.2 V 10	10	1.2	Variable stroke	3.0 ... 6.0	5 ... 75	Any	225
SNG-AP 10 1.2 V 20	10	1.2	Variable stroke	3.0 ... 6.0	5 ... 75	Any	400



## Design Data Needle Grippers SNG-AP

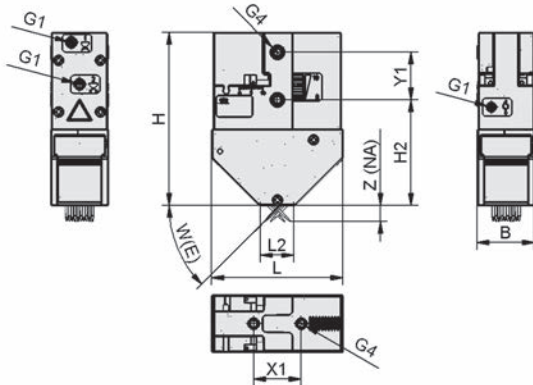

SNG-AP

Type	B [mm]	G1	G4	H [mm]	H2 [mm]	L [mm]	L2 [mm]	W(E) [°]	X1 [mm]	Y1 [mm]	Z (NA) [mm]
SNG-AP 10 0.8 V 3	35	M5-F	M5-F	80.2	46.1	65	28	30	29	29	3
SNG-AP 10 0.8 V 10	35	M5-F	M5-F	105.5	64.4	80	22	45	29	29	10
SNG-AP 10 1.2 V 3	35	M5-F	M5-F	80.2	46.1	65	28	30	29	29	3
SNG-AP 10 1.2 V 10	35	M5-F	M5-F	105.5	64.4	80	22	45	29	29	10
SNG-AP 10 1.2 V 20	35	M5-F	M5-F	160.0	104.9	120	22	45	29	29	20

# Needle Grippers SNG-V

Needle stroke 0 mm to 25 mm (variable)



## Suitability for Industry Specific Applications

### Applications

- Needle gripper for handling non-rigid and highly porous materials (primarily textiles)
- Handling materials that are difficult to grip using vacuum such as composite textiles, fleece, filter materials, insulation and foam materials etc.



Needle Grippers SNG-V

### Design

- Robust aluminum housing (1)
- Drive via double-acting pneumatic cylinders (2)
- 6 or 10 needles with diameter 0.8 mm, 1.2 mm or 1.5 mm (3)
- Insertion angle 30°
- Continuously variable stroke adjustment (4)
- Optional mounting with holder system HTS

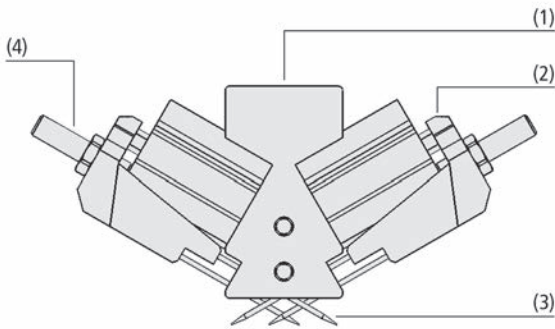

System Design Needle Grippers SNG-V

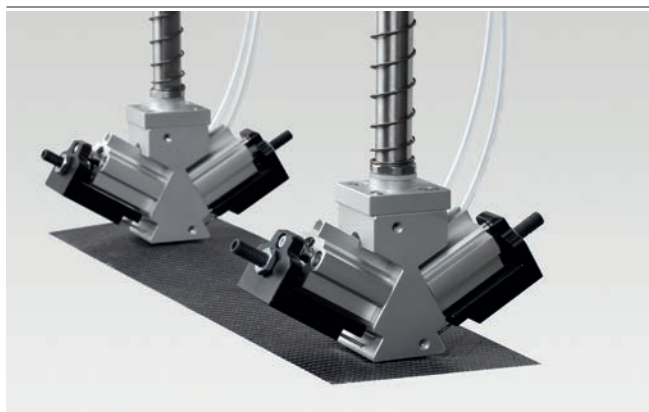

Needle grippers SNG-V being used for handling composite textiles

### Our Highlights...

- Intersecting needles
- Minimized active contact surface
- Double-acting pneumatic cylinders
- Variable needle stroke

### Your Benefits...

- High holding force, even for flexible, non-rigid workpieces
- Handling of small workpieces possible
- Very short cycle times
- Individual adjustment for different workpiece thicknesses, sizes and shapes



- Schmalz – The Company
- Vacuum Suction Cups
- Special Grippers
- Gripping Systems
- Clamping Systems
- Mounting Elements
- Vacuum Generators
- Valve Technology
- Switches and Monitoring
- Filters and Connections
- Services
- Contact
- Glossary
- Index of Products

# Needle Grippers SNG-V

Needle stroke 0 mm to 25 mm (variable)



## Designation Code Needle Grippers SNG-V

<b>SNG-V</b>	-	<b>10</b>	-	<b>1.2</b>	-	<b>V</b>	-	<b>7</b>
1		2		3		4		5

### 1 – Abbreviated designation

Code	Version
SNG-V	Crossed needles

### 2 – Number of needles

Code	Number
6...10	6 and 10

### 3 – Needle diameter

Code	Diameter in mm
0.8...1.5	ø 0.8 to 1.5

### 4 – Product addition

Code	Type
V	Variable needle stroke
V-HT	Variable needle stroke and high temperature
S	Narrow shape
V-HP	Variable needle stroke and high force

### 5 – Needle stroke

Code	Stroke in mm
5...25	5 to 25

Needle gripper SNG-V is delivered assembled.

Available spare parts: needle module, gripping surface

Available accessories: mounting plate (BEF-PL), holder system (HTS)



## Ordering Data Needle Grippers SNG-V

Type*	Part no.
SNG-V 6 0.8 V-S-5	10.01.29.00555
SNG-V 6 1.2 V-S-5	10.01.29.00539
SNG-V 6 1.5 V-HP-25	10.01.29.00568
SNG-V 10 1.2 V-7	10.01.29.00176
SNG-V 10 1.2 V-HT-7	10.01.29.00428
SNG-V 10 1.2 V-HP-18	10.01.29.00547

\*SNG-V HT for operating temperatures from 5 to 150° C and a maximum workpiece temperature of 260° C



## Ordering Data Spare Parts Needle Grippers SNG-V

Type	Spare Parts*	Part no.
SNG-V 6 0.8 V-S-5	Needle module	ERS-SET SNG-V 6 0.8 5 10.01.29.00556
SNG-V 6 1.2 V-S-5	Needle module	ERS-SET SNG-V 6 1.2 5 10.01.29.00546
SNG-V 6 1.5 V-HP-25	Needle module	ERS-SET SNG-V-HP 6 1.5 25 10.01.29.00576
SNG-V 10 1.2 V-7	Needle module	ERS-SET SNG-V 10 1.2 10.01.29.00238
SNG-V 10 1.2 V-HT-7	Needle module	ERS-SET SNG-V-HT 1.2 10.01.29.00464
SNG-V 10 1.2 V-HP-18	Needle module	ERS-SET SNG-V-HP 10 1.2 18 10.01.29.00550

\*Set of two needle housings with needles

Type	Spare Parts	Part no.
SNG-V 10 1.2 V-HT-7	Gripping surface	ERS-SET SNG-V-HT 10.01.29.00485
SNG-V 10 1.2 V-HP-18	Gripping surface	ERS-SET SNG-V-HP-HT 10 1.2 18 10.01.29.00522



# Needle Grippers SNG-V

Needle stroke 0 mm to 25 mm (variable)

## Ordering Data Accessories Needle Grippers SNG-V

Type	Mounting plate (top)	Mounting plate	Holder system HTS-A2	Holder system HTS-A3
SNG-V 6 0.8 V-S-5	-	10.01.29.00403	10.01.29.00402	10.01.29.00322
SNG-V 6 1.2 V-S-5	-	10.01.29.00403	10.01.29.00402	10.01.29.00322
SNG-V 6 1.5 V-HP-25	-	10.01.29.00403	10.01.29.00402	10.01.29.00322
SNG-V 10 1.2 V-7	10.01.29.00093	-	10.01.17.00169	10.01.17.00170
SNG-V 10 1.2 V-HT-7	10.01.29.00093	10.01.29.00403	10.01.29.00402	10.01.29.00322
SNG-V 10 1.2 V-HP-18	-	10.01.29.00403	10.01.29.00402	10.01.29.00322

## Technical Data Needle Grippers SNG-V

Type	Number of needles	Needle diameter [mm]	Add. function	Pressure range (operating pressure) [bar]	Operating temperature [°C]	Installation position	Weight [g]	Needle stroke Z (NA) [mm]
SNG-V 6 0.8 V-S-5	6	0.8	Variable stroke	3.0 ... 6.0	5 ... 60	Any	85	5
SNG-V 6 1.2 V-S-5	6	1.2	Variable stroke	3.0 ... 6.0	5 ... 60	Any	85	5
SNG-V 6 1.5 V-HP-25	6	1.5	Variable stroke, high force	3.0 ... 7.0	5 ... 60	Any	1,140	25
SNG-V 10 1.2 V-7	10	1.2	Variable stroke	3.0 ... 7.0	5 ... 60	Any	265	7
SNG-V 10 1.2 V-HP-18	10	1.2	Variable stroke, high force	3.0 ... 7.0	5 ... 80	Any	930	18
SNG-V 10 1.2 V-HT-7	10	1.2	Var. stroke, high temperature	3.0 ... 7.0	5 ... 150	Any	255	7

## Design Data Needle Grippers SNG-V

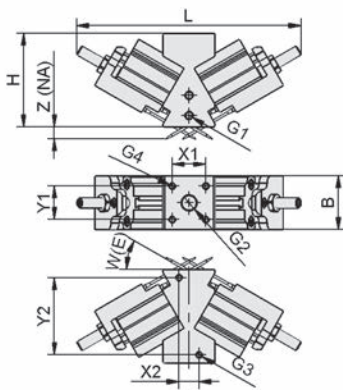

SNG-V

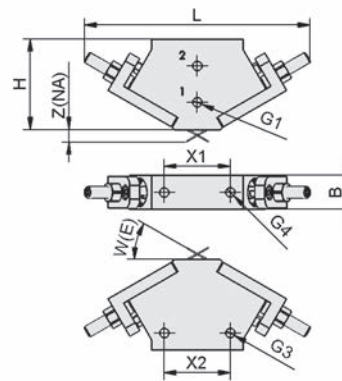

SNG-V S



# Needle Grippers SNG-V

Needle stroke 0 mm to 25 mm (variable)



## Design Data Needle Grippers SNG-V

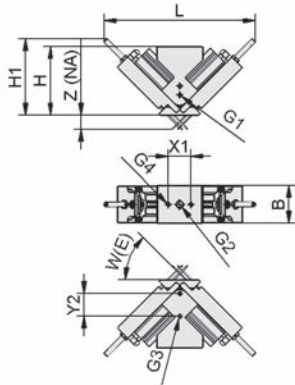

SNG-V HP

Type	B [mm]	G1	G2	G3	G4	H [mm]	H1 [mm]	L [mm]	W(E) [°]	X1 [mm]	X2 [mm]	Y1 [mm]	Y2 [mm]	Z (NA) [mm]
SNG-V 6 0.8 V-S-5	15	M5-F	-	M5-F	M5-F	40	-	115	30	29	29	-	-	5
SNG-V 6 1.2 V-S-5	15	M5-F	-	M5-F	M5-F	40	-	115	30	29	29	-	-	5
SNG-V 6 1.5 V-HP-25	48	M5-F	G1/8"-F	M5-F	M5-F	88	111.6	229	45	29	-	-	29	25
SNG-V 10 1.2 V-7	32	M5-F	G1/8"-F	M4-F	M4-F	56	-	149	30	20	12	20	46	7
SNG-V 10 1.2 V-HT-7	32	M5-F	G1/8"-F	M5-F	M4-F	56	-	149	30	20	-	20	29	7
SNG-V 10 1.2 V-HP-18	48	M5-F	G1/8"-F	M5-F	M5-F	88	97.4	237	45	29	-	-	29	18

Schmalz – The Company  
 Vacuum Suction Cups  
 Special Grippers  
 Gripping Systems  
 Clamping Systems  
 Mounting Elements  
 Vacuum Generators  
 Valve Technology  
 Switches and Monitoring  
 Filters and Connections  
 Services  
 Contact  
 Glossary  
 Index of Products



# Needle Grippers SNG-M



Needle stroke 3 mm



## Suitability for Industry Specific Applications

### Applications

- Needle gripper for handling of flexible, non-rigid components
- Handling of materials which are difficult to grip with vacuum, such as composite textiles, fleece, filters, woven fibreglass or carbon-fibre, woven aramide, foam materials, etc.



Needle Grippers SNG-M

### Design

- Robust aluminum housing
- Four needles (2)
- Activated by compressed air, needles retracted by springs on the right (1) or optional above (3)
- Insertion angle 30°
- The needle gripper can be optionally connected using a mounting plate

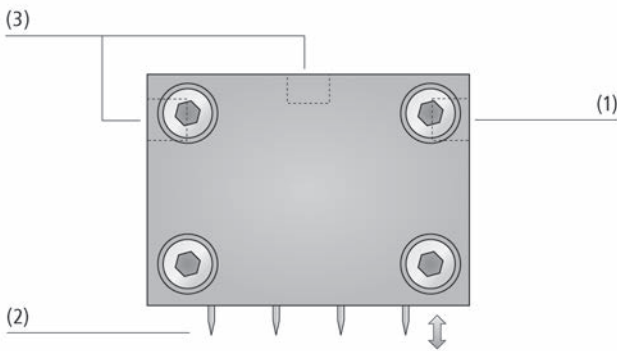

System Design Needle Grippers SNG-M

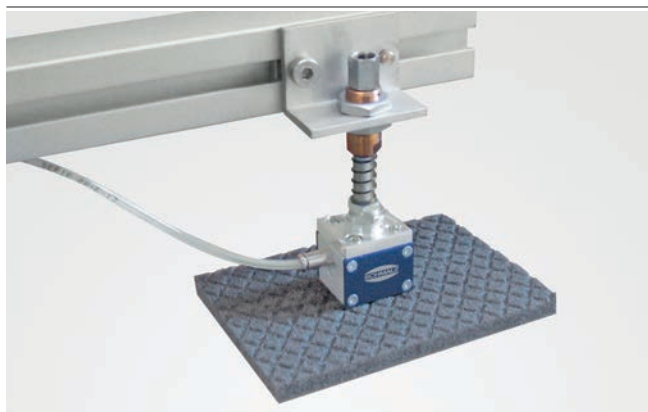

Needle grippers SNG-M being used for handling structured foam

### Our Highlights...

- Very small size
- Needles retracted by springs
- Synchronised extension of the needles
- Optionally available with adapter flange plate

### Your Benefits...

- Optimal for installation in restricted spaces
- Only one control signal
- Safe handling of the workpieces
- Perfect adaptation to other mounting components



- Schmalz – The Company
- Vacuum Suction Cups
- Special Grippers
- Gripping Systems
- Clamping Systems
- Mounting Elements
- Vacuum Generators
- Valve Technology
- Switches and Monitoring
- Filters and Connections
- Services
- Contact
- Glossary
- Index of Products

# Needle Grippers SNG-M

Needle stroke 3 mm



## Designation Code Needle Grippers SNG-M

<b>SNG-M</b>	-	<b>4</b>	-	<b>0.8</b>
<b>1</b>		<b>2</b>		<b>3</b>

### 1 – Abbreviated designation

Code	Version
SNG-M	Small size

### 2 – Number of needles

Code	Number
4	4

### 3 – Needle diameter

Code	Diameter in mm
0.8	ø 0.8

Needle gripper SNG-M is delivered assembled. The assembly consists of:

- Gripper of type SNG-M

Available spare parts: needle module

Available accessories: mounting plate (BEF-PL)



## Ordering Data Needle Grippers SNG-M

Type*	Part no.
SNG-M 4 0.8	10.01.29.00001

\*Suitable screw in push fittings can be found under "Screw in push fittings" in section "Filters and Connections"



## Ordering Data Spare Parts Needle Grippers SNG-M

Type	Spare Parts*	Part no.
SNG-M 4 0.8	Needle module	ERS-SET SNG-M 4 0.8 10.01.29.00094

\*Set of 4 needles with guide pistons and springs



## Ordering Data Accessories Needle Grippers SNG-M

Type	Accessories*	Part no.
SNG-M 4 0.8	Mounting plate	BEF-PL 31x34x11.5 G1/4-IG SNG 10.01.29.00093

\*Complete with mounting screws



## Technical Data Needle Grippers SNG-M

Type	Number of needles	Needle diameter [mm]	Pressure range (operating pressure) [bar]	Operating temperature [°C]	Installation position	Weight [g]
SNG-M 4 0.8	4	0.8	4.0 ... 6.0	5 ... 60	Any	80

# Needle Grippers SNG-M

Needle stroke 3 mm



## Design Data Needle Grippers SNG-M

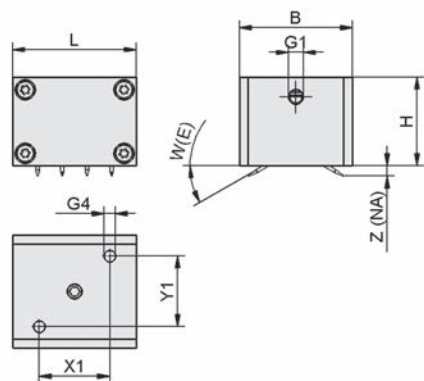

SNG-M

Type	B [mm]	G1	G4	H [mm]	L [mm]	W(E) [°]	X1 [mm]	Y1 [mm]	Z (NA) [mm]
SNG-M 4 0.8	32	M5-F	M4-F	25	35	30	20	20	3



- Schmalz – The Company
- Vacuum Suction Cups
- Special Grippers
- Gripping Systems
- Clamping Systems
- Mounting Elements
- Vacuum Generators
- Valve Technology
- Switches and Monitoring
- Filters and Connections
- Services
- Contact
- Glossary
- Index of Products

# Wafer Grippers SWGm

Two suction areas suitable for wafer sizes 125 x 125 mm and 156 x 156 mm

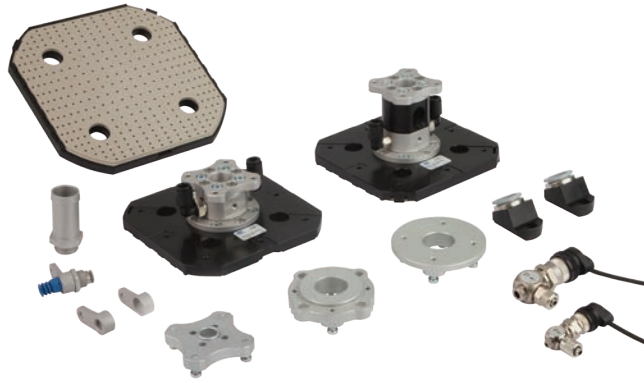

Wafer Grippers SWGm

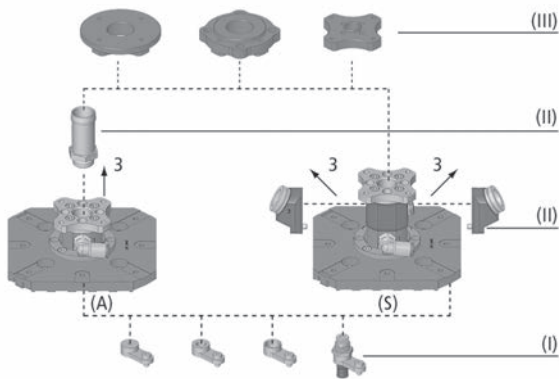

System Design Wafer Grippers SWGm

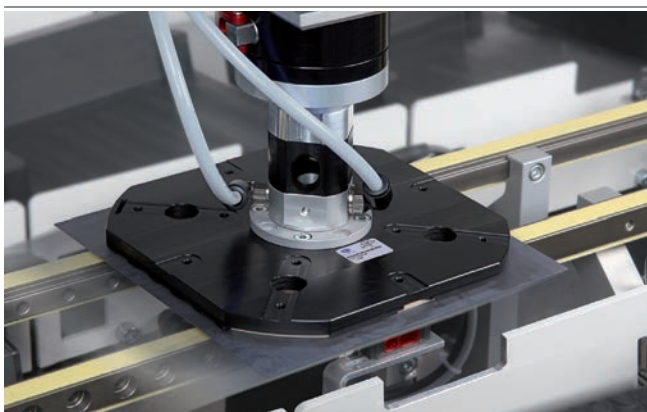

Wafer grippers SWGm being used for handling solar cells

## Suitability for Industry Specific Applications

### Applications

- Wafer gripper for extremely fast and gentle handling of wafers and solar cells in the production processes
- Loading and unloading from stacks and conveyor belts
- Exact positioning during the visual inspection and position measurement allow for on-the-fly breakage detection during the handling process
- Fully or partially automated production of PV cells with maximum process stability, production line uptime, cell efficiency and line output

### Design

- Base model version with discharging exhaust air (3) in axial (A) or lateral (S) direction
- Suction area geometries available in common cell sizes 125 mm and 156 mm (5" and 6")
- Optional component (II) for controlled discharging of exhaust air
- Modular design with accessories for the mounting of sensors and modules for suction and damping (I) and a selection of flange modules (III)
- Minimal overall height through reduced-weight plastic design
- Replaceable contact surfaces

### Our Highlights...

- Low overall height and operating weight
- Optimum allocation and dimension of the suction points
- High suction rate even for partial coverage or leakages

### Your Benefits...

- High speed, high accuracy handling for cycle times below one second
- Less operating cost
- Reliable gripping and handling, even for deformed, broken or perforated wafers

# Wafer Grippers SWGm

Two suction areas suitable for wafer sizes 125 x 125 mm and 156 x 156 mm

## Designation Code Wafer Grippers SWGm

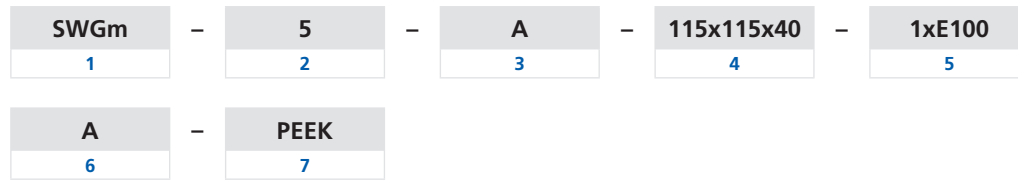

### 1 – Abbreviated designation

Code	Version
SWGm	SWGm

### 2 – Size

Code	Size in inch
5...6	5 to 6

### 3 – Design

Code	Type
A	Axial exhaust air
S	Lateral exhaust air

### 4 – Dimensions

Code	Dimensions in mm
115x115x40...	115x115x40 and
146x146x65	146x146x65

### 5 – Performance class of ejector

Code	Performance class of ejector
1xE100	1xE100

### 6 – Blow off function

Code	Type
A	Blow off function

### 7 – Material suction area

Code	Material suction area
PEEK	Polyetheretherketon

Wafer gripper SWGm is delivered assembled. The assembly consists of:

- Wafer gripper of type SWGm – available in various dimensions, with axial or lateral exhaust

Available spare parts: suction area

Available accessories: holder system, suction/absorption module, floating suction cup module, exhaust duct, exhaust air set, solenoid valves, flange plate

## Ordering Data Wafer Grippers SWGm

Type	Part no.
SWGm-5A 115x115x40 1xE100 A PEEK	10.01.30.00135
SWGm-6A 146x146x40 1xE100 A PEEK	10.01.30.00136
SWGm-5S 115x115x65 1xE100 A PEEK	10.01.30.00137
SWGm-6S 146x146x65 1xE100 A PEEK	10.01.30.00138

## Ordering Data Spare Parts Wafer Grippers SWGm

Type	Spare Parts		Part no.
SWGm-5A 115x115x40 1xE100 A PEEK	Suction area	SAUG-FL SWGm-5 110x110 PEEK	10.01.30.00125
SWGm-6A 146x146x40 1xE100 A PEEK	Suction area	SAUG-FL SWGm-6 141x141 PEEK	10.01.30.00126
SWGm-5S 115x115x65 1xE100 A PEEK	Suction area	SAUG-FL SWGm-5 110x110 PEEK	10.01.30.00125
SWGm-6S 146x146x65 1xE100 A PEEK	Suction area	SAUG-FL SWGm-6 141x141 PEEK	10.01.30.00126

Two suction areas suitable for wafer sizes 125 x 125 mm and 156 x 156 mm



## Ordering Data Accessories Wafer Grippers SWGm

Type	Flange plate AD1	Flange plate UNI	Flange plate ST1	Flange plate JP1	Flange plate EL1	Flange plate AB1	Holder system HTR-UNI	Holder system HTR M8
SWGm-5A 115x115x40 1xE100 A PEEK	10.01.30.00016	10.01.30.00017	10.01.30.00167	10.01.30.00194	-	-	10.01.30.00117	10.01.30.00118
SWGm-6A 146x146x40 1xE100 A PEEK	10.01.30.00016	10.01.30.00017	10.01.30.00167	10.01.30.00194	-	-	10.01.30.00117	10.01.30.00118
SWGm-5S 115x115x65 1xE100 A PEEK	10.01.30.00016	10.01.30.00017	10.01.30.00167	10.01.30.00194	10.01.30.00208	10.01.30.00015	10.01.30.00117	10.01.30.00118
SWGm-6S 146x146x65 1xE100 A PEEK	10.01.30.00016	10.01.30.00017	10.01.30.00167	10.01.30.00194	10.01.30.00208	10.01.30.00015	10.01.30.00117	10.01.30.00118

Type	Holder system HTR M12	Suction-/absorption module	Floating suction cup module	Solenoid valve EMV 1.5	Solenoid valve EMV 2.5	Exhaust duct	Exhaust air set
SWGm-5A 115x115x40 1xE100 A PEEK	10.01.30.00119	10.01.30.00121	10.01.01.12912	10.05.01.00288	10.05.01.00289	10.01.30.00087	-
SWGm-6A 146x146x40 1xE100 A PEEK	10.01.30.00119	10.01.30.00121	10.01.01.12912	10.05.01.00288	10.05.01.00289	10.01.30.00087	-
SWGm-5S 115x115x65 1xE100 A PEEK	10.01.30.00119	10.01.30.00121	10.01.01.12912	10.05.01.00288	10.05.01.00289	-	10.01.30.00059
SWGm-6S 146x146x65 1xE100 A PEEK	10.01.30.00119	10.01.30.00121	10.01.01.12912	10.05.01.00288	10.05.01.00289	-	10.01.30.00059



## Technical Data Wafer Grippers SWGm

Type	Holding Force [N]	Suction rate [l/min]	Air consumption [l/min]	Pressure range (operating pressure) [bar]	Operating temperature [°C]	Weight [g]
SWGm-5A 115x115x40 1xE100 A PEEK	10 ... 35	190...350	60...120	1.0 ... 3.0	5 ... 40	210
SWGm-6A 146x146x40 1xE100 A PEEK	12 ... 43	190...350	60...120	1.0 ... 3.0	5 ... 40	275
SWGm-5S 115x115x65 1xE100 A PEEK	10 ... 35	160...235	60...120	1.0 ... 3.0	5 ... 40	235
SWGm-6S 146x146x65 1xE100 A PEEK	12 ... 43	160...235	60...120	1.0 ... 3.0	5 ... 40	300



## Performance Data Wafer Grippers SWGm

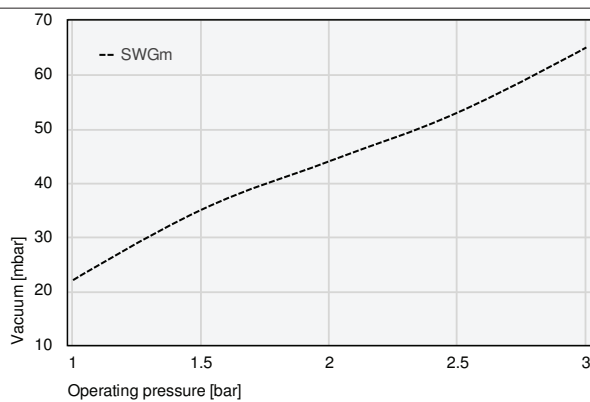

Achievable vacuum at various operating pressures

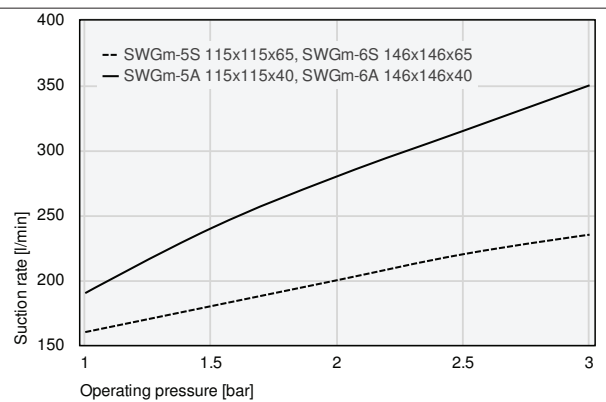

Suction capacity at various degrees of evacuation



Two suction areas suitable for wafer sizes 125 x 125 mm and 156 x 156 mm

## Performance Data Wafer Grippers SWGm

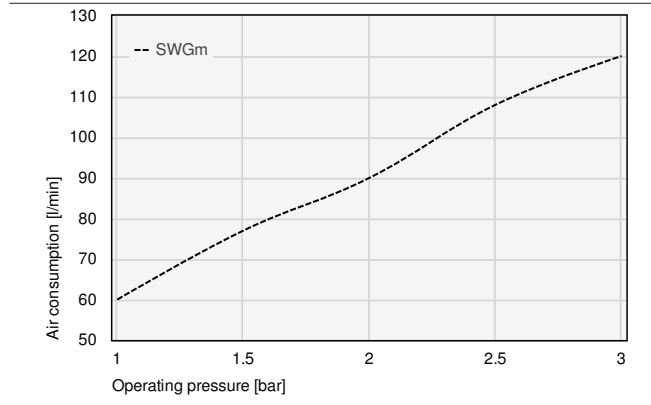

Air consumption

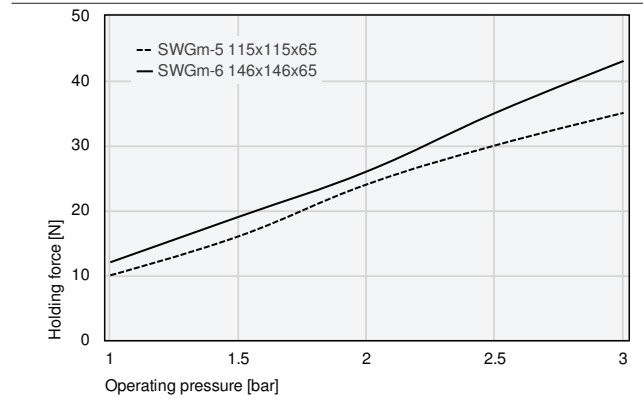

Holding force

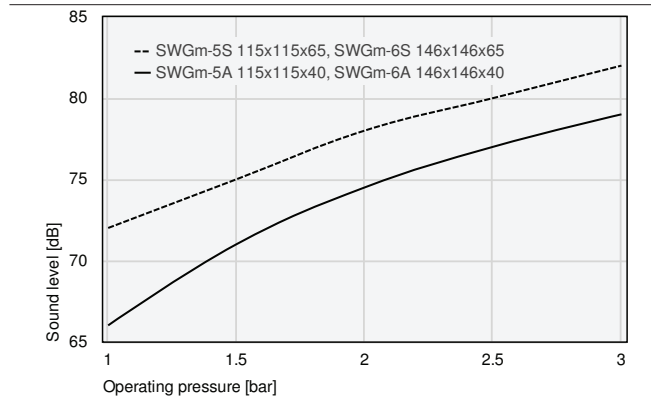

Noise level free at various operating pressures

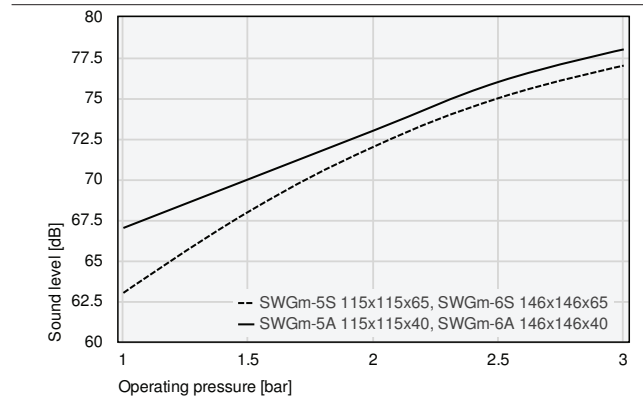

Noise level workpiece gripped at various operating pressures

## Design Data Wafer Grippers SWGm

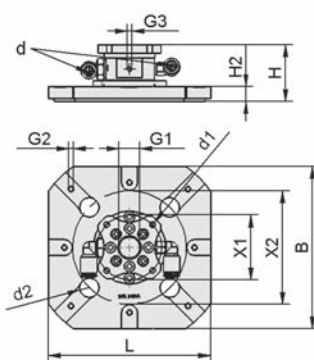

SWGm-5A, SWGm-6A

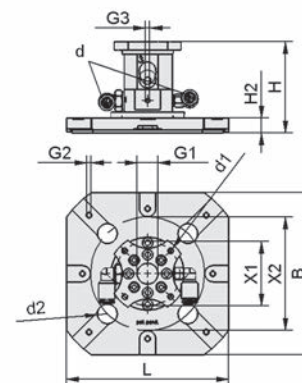

SWGm-5S, SWGm-6S



# Wafer Grippers SWGm

Two suction areas suitable for wafer sizes 125 x 125 mm and 156 x 156 mm



## Design Data Wafer Grippers SWGm

Type	B [mm]	d [mm]	d1 [mm]	d2 [mm]	G1	G2	G3	H [mm]	H2 [mm]	L [mm]	X1 [mm]	X2 [mm]
SWGm-5A 115x115x40 1xE100 A PEEK	115	6	4	14	G3/8"-F	M4-F	M4-F	40	10.5	115	46	80.6
SWGm-6A 146x146x40 1xE100 A PEEK	146	6	4	14	G3/8"-F	M4-F	M4-F	40	10.5	146	46	110.6
SWGm-5S 115x115x65 1xE100 A PEEK	115	6	4	14	G3/8"-F	M4-F	M4-F	65	10.5	115	46	80.6
SWGm-6S 146x146x65 1xE100 A PEEK	146	6	4	14	G3/8"-F	M4-F	M4-F	65	10.5	146	46	110.6

# Flow Grippers SCG



Suction rate from 270 l/min to 650 l/min



## Suitability for Industry Specific Applications

### Applications

- Flow gripper for handling sensitive plastic parts, printed circuit boards, textiles and composite materials
- Handling circuit boards with openings or drillings; process-reliable handling even with low occupancy rate of the suction surface and with minimal surface pressure
- Contact element made of FDA compliant material allows direct, repeated contact with dry foods such as biscuits, cookies, cakes and waffles
- Handling of blank circuit boards



Flow Grippers SCG

### Design

- Quick-change contact areas (3) with various diameters
- Anodized aluminum main body with integrated vacuum generation (2)
- Base model with capability for axial mounting (MA) or sideways mounting (MS) (5)
- Controlled exhaust air (4)
- Two compressed air connections for suction and blow off
- Silencer (1)

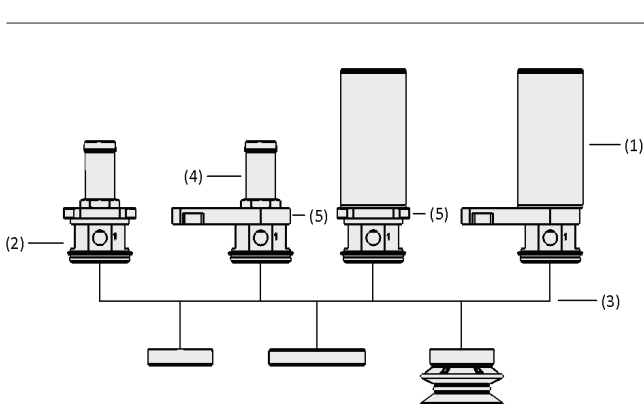

System Design Flow Grippers SCG

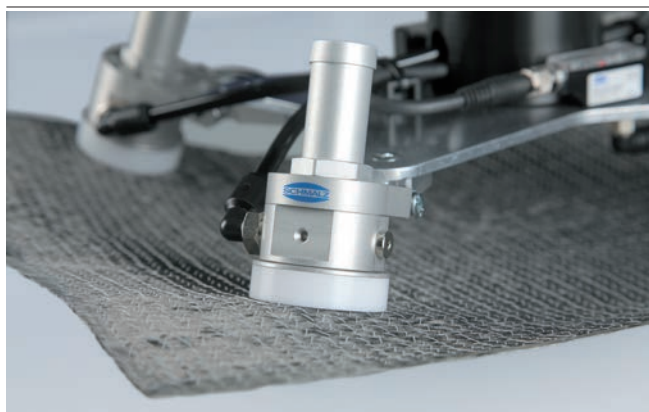

Flow Grippers SCG being used for handling composites

### Our Highlights...

- Suction area with suction openings placed close to each other
- Integrated vacuum generation
- Very high suction rate
- High suction rate with minimum air consumption
- Controlled air discharge

### Your Benefits...

- Prevents the workpiece from being sucked in or damaged
- Compact, ready-to-connect gripper unit
- Safe gripping, even with porous materials
- Low operating costs
- No contamination of process area



Schmalz – The Company  
Vacuum Suction Cups  
Special Grippers  
Gripping Systems  
Clamping Systems  
Mounting Elements  
Vacuum Generators  
Valve Technology  
Switches and Monitoring  
Filters and Connections  
Services  
Contact  
Glossary  
Index of Products

# Flow Grippers SCG

Suction rate from 270 l/min to 650 l/min



## Designation Code Flow Grippers SCG

<b>SCG</b>	-	<b>1xE100</b>	-	<b>A</b>	-	<b>MA</b>	-	<b>SDA</b>
1		2		3		4		5

### 1 – Abbreviated designation

Code	Version
SCG	SCG

### 2 – Performance class of ejector

Code	Performance class of ejector
1xE100	1xE100

### 3 – Blow off function

Code	Blow off function
A	Blow off function

### 4 – Possibility for mounting

Code	Possibility for mounting
MA	Mounting axial
MS	Mounting sideways

### 5 – Product addition

Code	Type
SDA	Silencer axial

Flow gripper SCG is supplied as an individual part (without suction area).

In order to receive a complete gripper the following ordering steps are required:

- Flow gripper SCG – available for axial or sideways mounting
- Suction area of type SAUG-FL/SAUG-SCG – available in various dimensions



## Ordering Data Flow Grippers SCG

Type	Part no.
SCG 1xE100 A MA	10.01.30.00092
SCG 1xE100 A MS	10.01.30.00170
SCG 1xE100 A MA SDA	10.01.30.00359
SCG 1xE100 A MS SDA	10.01.30.00360



## Ordering Data Accessories Flow Grippers SCG

Type		Part no.
Suction cup (round)	SAUG-SCG 20 SI-HD	10.01.30.00661
Suction cup (round)	SAUG-SCG 30 SI-HD	10.01.30.00655
Suction cup (round)	SAUG-SCG 40 SI-HD	10.01.30.00660
Suction cup (round)	SAUG-SCG 50 SI-HD	10.01.30.00593
Suction cup (round)	SAUG-SCG 20 NBR-AS-55	10.01.30.00716
Suction cup (round)	SAUG-SCG 30 NBR-AS-55	10.01.30.00717
Suction cup (round)	SAUG-SCG 40 NBR-AS-55	10.01.30.00718
Suction cup (round)	SAUG-SCG 50 NBR-AS-55	10.01.30.00719
Suction area	SAUG-FL SCG 40 POM	10.01.30.00030
Suction area	SAUG-FL SCG 60 POM	10.01.30.00031

# Flow Grippers SCG

Suction rate from 270 l/min to 650 l/min



## Technical Data Flow Grippers SCG

Type*	Suction rate [l/min]	Air consumption [l/min]	Pressure range (operating pressure) [bar]**	Operating temperature [°C]	Recomm. internal hose diameter suction [mm]	Recomm. internal hose diameter blow off [mm]	Weight [g]
SCG 1xE100 A MA	270...650	60...200	1.0 ... 5.0	5 ... 75	4	4	85
SCG 1xE100 A MS	270...650	60...200	1.0 ... 5.0	5 ... 75	4	4	109
SCG 1xE100 A MA SDA	270...590	60...200	1.0 ... 5.0	5 ... 75	4	4	164
SCG 1xE100 A MS SDA	270...590	60...200	1.0 ... 5.0	5 ... 75	4	4	188

\*Using the silencer reduces the suction flow specified above by approx. 9 % and noise emissions by up to 12 dB(A).

\*\*The specified value can be equal for suction and blow off. Operating pressures below 1 bar are possible but have to be tested individually.



## Performance Data Flow Grippers SCG

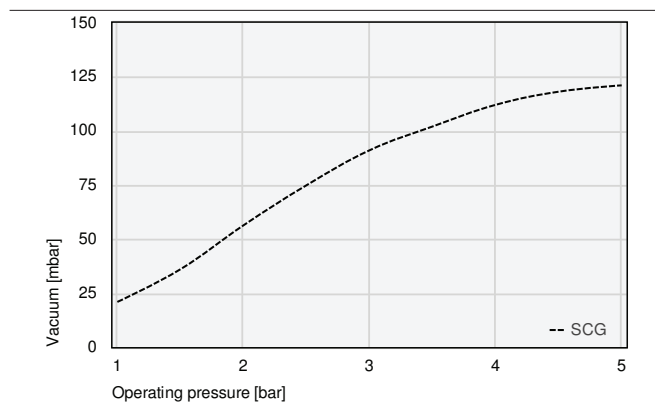

Achievable vacuum at various operating pressures

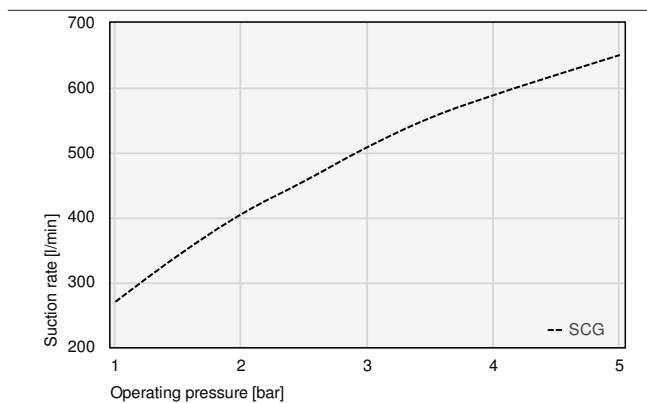

Suction capacity at various degrees of evacuation

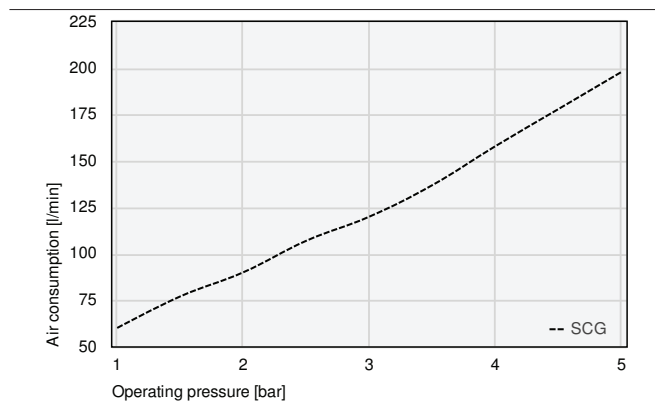

Air consumption



Schmalz - The Company  
Vacuum Suction Cups  
Special Grippers  
Gripping Systems  
Clamping Systems  
Mounting Elements  
Vacuum Generators  
Valve Technology  
Switches and Monitoring  
Filters and Connections  
Services  
Contact  
Glossary  
Index of Products

Suction rate from 270 l/min to 650 l/min



## Design Data Flow Grippers SCG

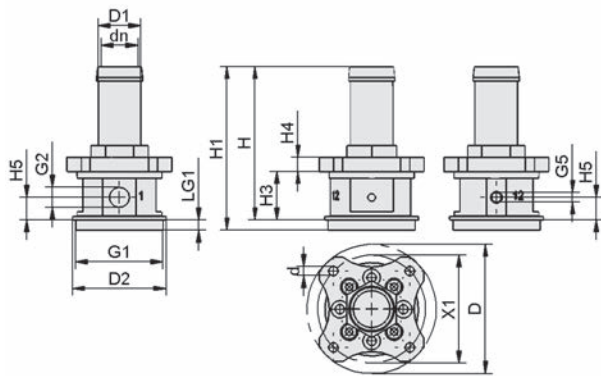

SCG A MA

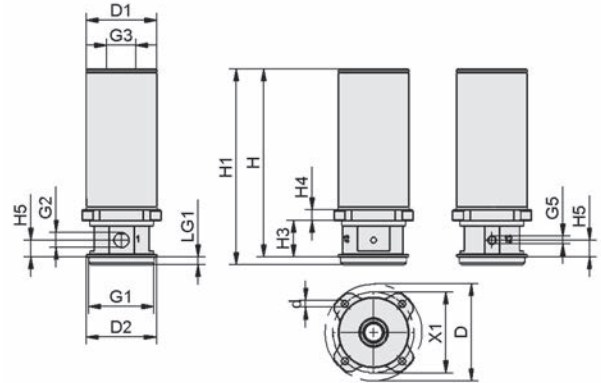

SCG A MA SDA

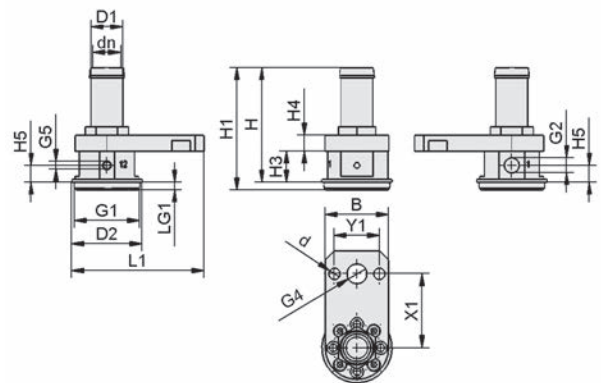

SCG A MS

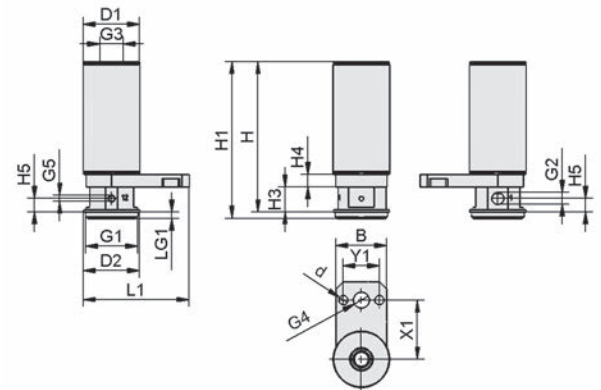

SCG A MS SDA

Type	B [mm]	d [mm]	dn [mm]	D [mm]	D1 [mm]	D2 [mm]	G1	G2	G3	G4
SCG 1xE100 A MA	-	4.0	12.5	55	18	39.8	M37x1-M	G1/8"-F	-	-
SCG 1xE100 A MS	36	6.6	12.5	-	18	39.8	M37x1-M	G1/8"-F	-	G1/4"-F
SCG 1xE100 A MA SDA	-	4.0	-	55	40	39.8	M37x1-M	G1/8"-F	G3/8"-F	-
SCG 1xE100 A MS SDA	36	6.6	-	-	40	39.8	M37x1-M	G1/8"-F	G3/8"-F	G1/4"-F

Type	G5	H [mm]	H1 [mm]	H3 [mm]	H4 [mm]	H5 [mm]	L1 [mm]	LG1 [mm]	X1 [mm]	Y1 [mm]
SCG 1xE100 A MA	M5-F	66	69.6	20.6	6	9.5	-	4.5	46	-
SCG 1xE100 A MS	M5-F	66	69.6	17.6	9	9.5	74.9	4.5	42	25.5
SCG 1xE100 A MA SDA	M5-F	107	111.1	20.6	6	9.6	-	4.5	46	-
SCG 1xE100 A MS SDA	M5-F	107	111.1	17.6	9	9.6	74.9	4.5	42	25.5

# Thin Glass Grippers STGG

Two suction areas 100 x 55 mm and 170 x 105 mm

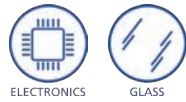

## Suitability for Industry Specific Applications

### Applications

- Special gripper for gentle handling of thinnest glass
- Use in the manufacturing of 0.1 mm thin display glass
- Extremely fast and gentle handling of sensitive workpieces in fully or semi-automated production of displays, e.g. TFT screens, smartphones or tablets
- Handling without contamination and thus no negative effect on subsequent processes such as coating

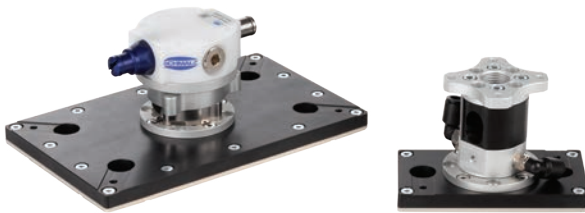

Thin Glass Grippers STGG

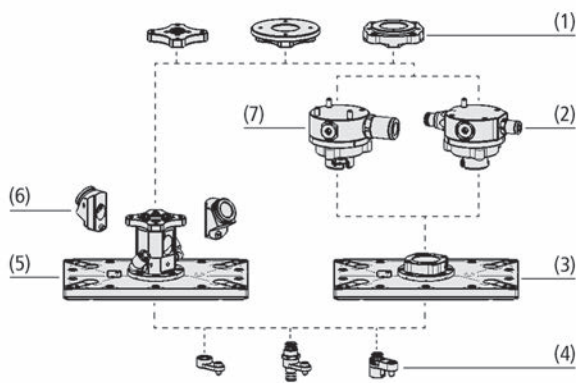

System Design Thin Glass Grippers STGG

### Design

- Basic body (5) made of lightweight plastic and aluminum with integrated vacuum generation and blow off function
- Basic body (3) made of lightweight plastic and aluminum with integrated vacuum generator (2); alternatively for connection to an external vacuum generator (7)
- PEEK suction area in standard sizes 100 x 55 mm and 170 x 105 mm, custom made sizes available on request
- Modular design: optional mounting of sensors and modules for suction and damping (4); different robot flange modules (1) available
- Optional exhaust unit (6) for controlled discharge of exhaust air for clean room applications



Thin glass gripper STGG for handling display glass

### Our Highlights...

- Suction area made of the mark-free material PEEK
- High suction capacity and large effective suction area
- Active blow off function
- Full surface gripping with a low vacuum level
- Efficient vacuum generation

### Your Benefits...

- No contamination of the glass surface
- Safe and precise handling in high dynamic processes
- Fast and exact depositing
- Minimum surface pressure for a very gentle handling process
- Low compressed air consumption, low operating costs

# Thin Glass Grippers STGG

Two suction areas 100 x 55 mm and 170 x 105 mm



## Designation Code Thin Glass Grippers STGG

<b>STGG</b>	-	<b>S</b>	-	<b>100x55</b>	-	<b>1xE100</b>	-	<b>A</b>	-	<b>PEEK</b>
<b>1</b>		<b>2</b>		<b>3</b>		<b>4</b>		<b>5</b>		<b>6</b>

### 1 – Abbreviated designation

Code	Version
STGG	STGG

### 2 – Design

Code	Type
S	Lateral exhaust air

### 3 – Dimensions

Code	Dimensions in mm
100x55...170x105	100x55 and 170x105

### 4 – Vacuum generation

Code	Vacuum generation
1xE100	1xE100 integrated
QCMV HV 2 13	QCMV HV 2 13 integrated
QCM 51	QCM 51 external

### 5 – Blow off function

Code	Blow off function
A	Blow off function

### 6 – Material

Code	Material
PEEK	PEEK

Thin glass gripper STGG is delivered assembled.

- Gripper available in various dimensions with integrated vacuum generation (1xE100 or QCMV) or with connection for external vacuum generation (QCM)

Available accessories: exhaust air set, holder system, suction / damping module, floating suction cup module, flange plate



## Ordering Data Thin Glass Grippers STGG

Type	Part no.
STGG S 100x55 1xE100 A PEEK	10.01.30.00469
STGG S 170x105 1xE100 A PEEK	10.01.30.00473
STGG 100x55 QCMV HV 2 13 PEEK	10.01.30.00517
STGG 170x105 QCMV HV 2 13 PEEK	10.01.30.00518
STGG 100x55 QCM 51 PEEK	10.01.30.00519
STGG 170x105 QCM PEEK	10.01.30.00520



## Ordering Data Accessories Thin Glass Grippers STGG

Type	Part no.
Floating suction cup module	SBSm 14 90-3 4/2 0 10.01.01.12912
Floating suction cup module	SBSm 14 90-3 4/2 90 10.01.01.13171
Flange plate (round)	FLAN-PL 55x7.5-AB1 10.01.30.00015
Flange plate (round)	FLAN-PL 63x10.5-AD1 10.01.30.00016
Flange plate (round)	FLAN-PL 63x11.5-UNI 10.01.30.00017
Flange plate (round)	FLAN-PL 80x9-ST1 10.01.30.00167
Flange plate (round)	FLAN-PL 55x9.5-JP1 10.01.30.00194
Flange plate (round)	FLAN-PL 55x7.5-EL1 10.01.30.00208
Holder system	HTR-UNI SWGm 10.01.30.00117
Holder system	HTR M8x1-IG SWGm 10.01.30.00118
Holder system	HTR M12x1-IG SWGm 10.01.30.00119
Suction-/ damping module	SD-MOD 4 32x15x35 FG 9 SWGm 10.01.30.00121
Exhaust air set	ABL-SET 14 SWG/SCG 10.01.30.00059



# Thin Glass Grippers STGG

Two suction areas 100 x 55 mm and 170 x 105 mm

## Technical Data Thin Glass Grippers STGG

Type	Holding Force [N]	Suction rate [l/min]	Air consumption [l/min]	Pressure range (operating pressure) [bar]	Operating temperature [°C]	Weight [g]
STGG S 100x55 1xE100 A PEEK	4 ... 15	160...235	60...120	1.0 ... 3.0	5 ... 60	215
STGG S 170x105 1xE100 A PEEK	13 ... 45	160...235	60...120	1.0 ... 3.0	5 ... 60	360
STGG 100x55 QCMV HV 2 13 PEEK	30 ... 56	31...38	18...28	3.0 ... 5.0	5 ... 60	300
STGG 170x105 QCMV HV 2 13 PEEK	85 ... 160	31...38	18...28	3.0 ... 5.0	5 ... 60	450

Type	Flow rate max. [m³/h]	Operating temperature [°C]	Weight [g]
STGG 100x55 QCM 51 PEEK	20	5 ... 60	325
STGG 170x105 QCM PEEK	20	5 ... 60	475

## Performance Data Thin Glass Grippers STGG

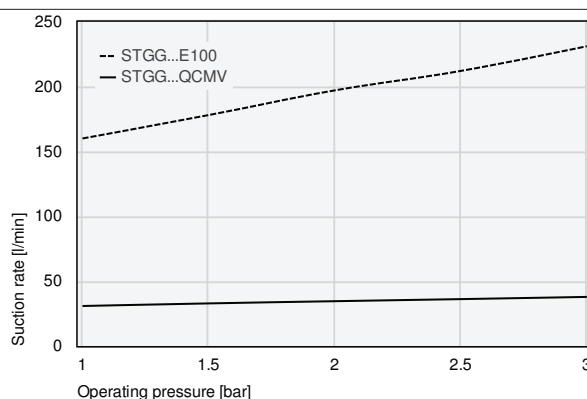
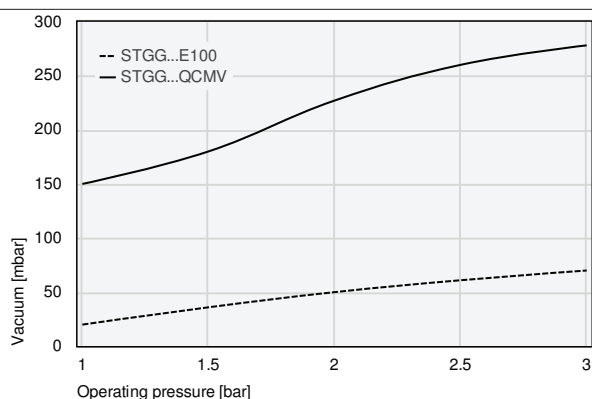

Achievable vacuum at various operating pressures

Suction capacity at various degrees of evacuation

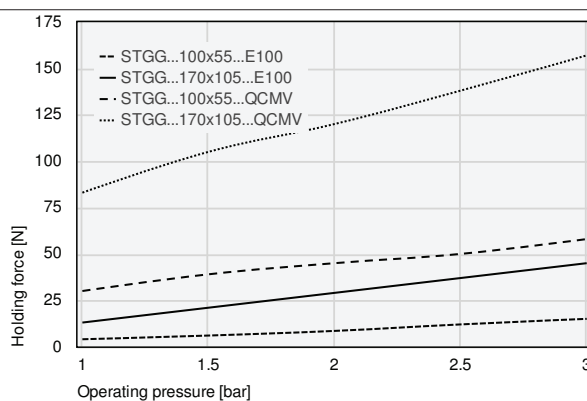
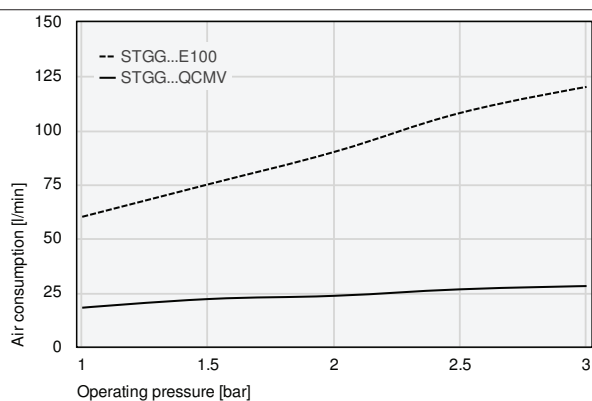

Air consumption

Holding force

Schmalz - The Company  
Vacuum Suction Cups  
Special Grippers  
Gripping Systems  
Clamping Systems  
Mounting Elements  
Vacuum Generators  
Valve Technology  
Switches and Monitoring  
Filters and Connections  
Services  
Contact  
Glossary  
Index of Products



# Thin Glass Grippers STGG

Two suction areas 100 x 55 mm and 170 x 105 mm



## Design Data Thin Glass Grippers STGG

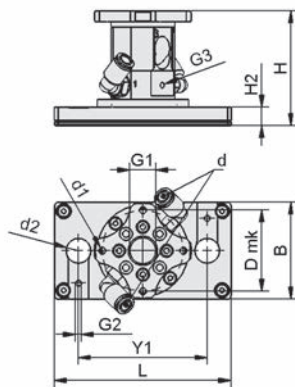

STGG S 100x55 1xE100 A

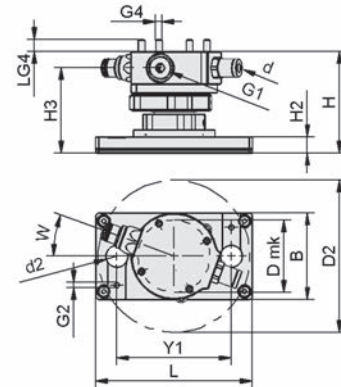

STGG 100x55 QCM / QCMV

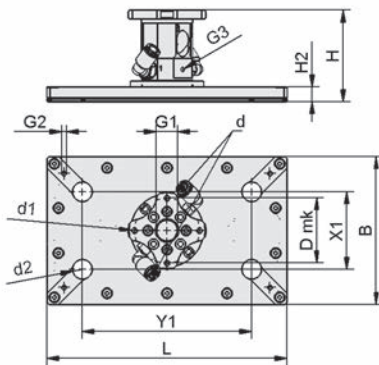

STGG S 170x105 1xE100 A

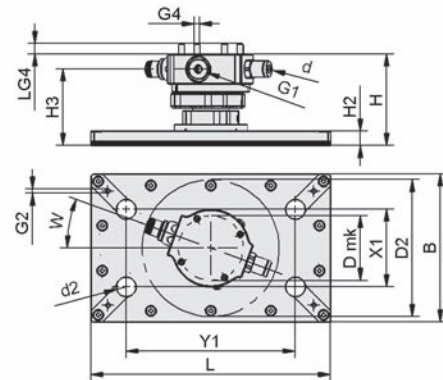

STGG 170x105 QCM / QCMV

Type	B [mm]	d [mm]	d1 [mm]	d2 [mm]	D2 [mm]	Dmk [mm]	G1	G2	G3	G4	H [mm]	H2 [mm]	H3 [mm]	L [mm]	LG4 [mm]	W [mm]	X1 [mm]	Y1 [mm]
STGG S 100x55 1xE100 A PEEK	55	6	4	14	-	46	G3/8"-F	M4-F	M4-F	-	65	11	-	100	-	-	-	73
STGG S 170x105 1xE100 A PEEK	105	6	4	14	-	46	G3/8"-F	M4-F	M4-F	-	65	11	-	170	-	-	55	120
STGG 100x55 QCMV HV 2 13 PEEK	55	6	-	14	97	46	G1/8"-F	M4-F	-	M4-M	68	11	57	100	8	20	-	73
STGG 170x105 QCMV HV 2 13 PEEK	105	6	-	14	97	46	G1/8"-F	M4-F	-	M4-M	68	11	57	170	8	20	55	120
STGG 100x55 QCM 51 PEEK	55	12	-	14	112	46	G1/8"-F	M4-F	-	M4-M	68	11	57	100	8	20	-	73
STGG 170x105 QCM PEEK	105	12	-	14	112	46	G1/8"-F	M4-F	-	M4-M	68	11	57	170	8	20	55	120

# Feed Ejectors SEC

Suction rate from 215 l/min to 8,640 l/min



## Suitability for Industry Specific Applications

### Applications

- Gripping of very porous materials such as foams, textiles, paper and various recycling materials
- Conveyance of light solids, such as polystyrene, plastic granulates, rice or other filling materials
- Exhaust of non-aggressive vapors and gases



Feed Ejectors SEC

### Design

- Body made of anodized aluminum or stainless steel
- Straight vacuum passage
- Compressed air enters at the side (1), through an annular gap

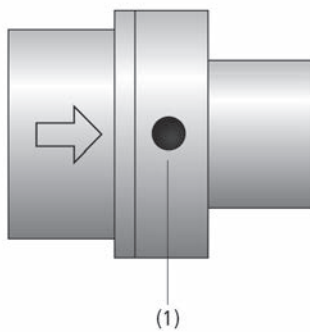

System Design Feed Ejectors SEC

### Our Highlights...

- Special ejector with straight vacuum passage for very high volume flow rates at low vacuum values
- Various models with different performance figures

### Your Benefits...

- Handling of very porous materials and low-loss transport of bulk goods; high efficiency
- Optimum range of sizes for all applications



Feed Ejector SEC for transporting granulates



- Schmalz – The Company
- Vacuum Suction Cups
- Special Grippers
- Gripping Systems
- Clamping Systems
- Mounting Elements
- Vacuum Generators
- Valve Technology
- Switches and Monitoring
- Filters and Connections
- Services
- Contact
- Glossary
- Index of Products

Suction rate from 215 l/min to 8,640 l/min



## Designation Code Feed Ejectors SEC

<b>SEC</b>	-	<b>100</b>	-	<b>A2</b>
1		2		3

### 1 – Abbreviated designation

Code	Version
SEC	SEC

### 2 – Nozzle size

Code	Nozzle size in mm
60...750	6 to 75

### 3 – Variant

Code	Type
A2	Stainless steel

Feed Ejector SEC is delivered as a ready-to-connect product.



## Ordering Data Feed Ejectors SEC

Type	Part no.
SEC-60	10.02.01.01079
SEC-60 A2	10.02.01.01155
SEC-100	10.02.01.00078
SEC-100 A2	10.02.01.01691
SEC-200	10.02.01.00079
SEC-200 A2	10.02.01.01326
SEC-400	10.02.01.00080
SEC-400 A2	10.02.01.01620
SEC-750	10.02.01.00081



## Technical Data Feed Ejectors SEC

Type	Nozzle size [mm]	Max. vacuum [mbar]	Suction rate (max.) [l/min]*	Suction rate (max.) [m³/h]	Air consumption suction [l/min]**	Air consumption suction [m³/h]	Pressure range (operating pressure) [bar]	Weight [kg]	Operating temperature [°C]
SEC-60	6	-245	215	12.9	110	6.6	2.0 ... 5.0	0.040	-20 ... 80
SEC-60 A2	6	-245	215	12.9	110	6.6	2.0 ... 5.0	0.091	-20 ... 80
SEC-100	10	-185	610	36.6	135	8.1	2.0 ... 6.0	0.070	-20 ... 80
SEC-100 A2	10	-185	610	36.6	135	8.1	2.0 ... 6.0	0.206	-20 ... 80
SEC-200	20	-85	1,375	82.5	290	17.4	2.0 ... 6.0	0.180	-20 ... 80
SEC-200 A2	20	-85	1,375	82.5	290	17.4	2.0 ... 6.0	0.511	-20 ... 80
SEC-400	40	-35	2,250	135.0	445	26.7	2.0 ... 6.0	0.525	-20 ... 80
SEC-400 A2	40	-35	2,250	135.0	445	26.7	2.0 ... 6.0	1.475	-20 ... 80
SEC-750	75	-5	8,640	518.4	770	46.2	2.0 ... 6.0	2.350	-20 ... 80

\*At optimal operating pressure of approx. 4.5 bar

\*\*At optimal operating pressure of approx. 4.5 bar

# Feed Ejectors SEC

Suction rate from 215 l/min to 8,640 l/min



## Design Data Feed Ejectors SEC

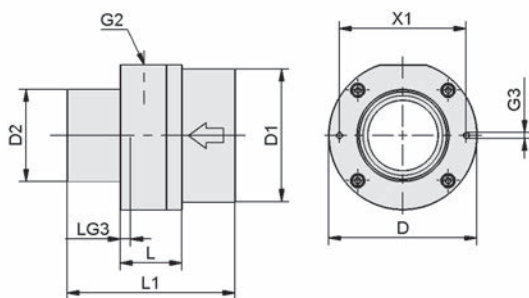

SEC

Type	D [mm]	D1 [mm]	D2 [mm]	G2	G3	L [mm]	L1 [mm]	LG3 [mm]	X1 [mm]
SEC-60	32	12.5	12.5	M5-F	M3-F	14	44	5	25
SEC-100	37	19.0	19.0	G1/8"-F	M4-F	21	70	8	29
SEC-200	50	38.0	32.0	G1/4"-F	M4-F	30	90	12	42
SEC-400	84	75.0	52.0	G3/8"-F	M4-F	35	95	14	72
SEC-750	140	125.0	100.0	G1/2"-F	M6-F	65	180	6	126



- Schmalz – The Company
- Vacuum Suction Cups
- Special Grippers
- Gripping Systems
- Clamping Systems
- Mounting Elements
- Vacuum Generators
- Valve Technology
- Switches and Monitoring
- Filters and Connections
- Services
- Contact
- Glossary
- Index of Products

# Suction-Cup Balance SSCB

Gripper area (Ø) 60 mm



Suction-Cup Balance SSCB

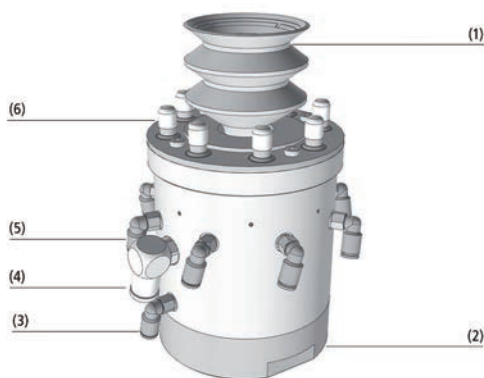

System Design Suction-Cup Balance SSCB



Automated gripping and clamping with the Suction-Cup Balance SSCB

## Suitability for Industry Specific Applications

### Applications

- Suction-Cup Balance SSCB for automated, precise gripping and clamping of various workpieces in a production line
- Ideal for securely gripping and clamping of uneven 3D free-form surfaces
- Mirrored gripping and clamping possible
- Driveless adjusting with no mechanical stops or positioning aids

### Design

- Flexible bellows suction cup (1) for adapting perfectly to the workpiece
- Aluminum main body (2)
- Compressed air supply (3) for spring force
- Vacuum supply (4) for suction cup
- Compressed air supply (5) for releasing positioning pins
- Positioning pins (6) with padded tips that are gentle on the workpiece

### Our Highlights...

- End effector for precise workpiece positioning
- Software controlled 3D freeform surface mapping using 2D reference surfaces
- Individually lockable, unpressurized positioning pins
- Special supporting material on workpiece contact surfaces

### Your Benefits...

- Flexible gripping and clamping system design possibilities
- Automated set-up process for gripping and clamping systems
- Gripping and clamping systems automatically adjust to workpiece contours
- Reliable and precise fixation of complex parts

Schmalz – The Company

Vacuum Suction Cups

Special Grippers

Gripping Systems

Clamping Systems

Mounting Elements

Vacuum Generators

Valve Technology

Switches and Monitoring

Filters and Connections

Services

Contact

Glossary

Index of Products



# Suction-Cup Balance SSCB

Gripper area (Ø) 60 mm



## Designation Code Suction-Cup Balance SSCB

<b>SSCB</b>	-	<b>78</b>	-	<b>141</b>	-	<b>EP</b>	-	<b>M6-IG</b>	-	<b>FSG</b>	-	<b>VU1</b>
1		2		3		4		5		6		7

### 1 – Abbreviated designation

Code	Version
SSCB	SSCB

### 2 – Positioning pins

Code	Dimensions in mm
78	ø 78 mm

### 3 – Operation height

Code	Dimensions in mm
141-171	141-171

### 4 – Locking positioning pin

Code	Type
EP	Individually locking pins
ZP	Simultaneously locking pins

### 5 – Connection

Code	Type
M6-IG	M6-IG (IG = female (F))
60	60 mm Innospann Intake

### 6 – Suction Cups

Code	Type
FSG	2.5 folds, round
SAB	1.5 folds, round

### 7 – Material Suction Cup

Code	Material
VU1	VU1
NBR	Nitrile caoutchuc

The Suction-Cup Balance SSCB is delivered assembled. The delivery consists of:

- Suction-Cup made of aluminum body with positioning pins
- Suction cup FSG-VU1 or SAB-NBR with diameter 60 mm

Available spare parts: suction cup (set of spare parts), cover (cap)



## Ordering Data Suction-Cup Balance SSCB

Type	Part no.
SSCB-78 141-171 EP M6-IG FSG-VU1	10.01.15.00850
SSCB-78 141-171 ZP M6-IG FSG-VU1	10.01.15.00922
SSCB-78 93.5-107.5 ZP 60 SAB-NBR	10.01.15.00572



## Ordering Data Spare Parts Suction-Cup Balance SSCB

Type	Spare Parts	Part no.
SSCB-78 141-171 EP M6-IG FSG-VU1	Set of spare parts	ERS-SET SSCB-FG60-VU1
SSCB-78 141-171 ZP M6-IG FSG-VU1	Set of spare parts	ERS-SET SSCB-FG60-VU1

Type	Spare Parts	Part no.
SSCB-78 141-171 EP M6-IG FSG-VU1	Cap (round)	KAPP 7x10.5 SSCB
SSCB-78 141-171 ZP M6-IG FSG-VU1	Cap (round)	KAPP 7x10.5 SSCB
SSCB-78 93.5-107.5 ZP 60 SAB-NBR	Cap (round)	KAPP 7x10.5 SSCB

# Suction-Cup Balance SSCB

Gripper area (Ø) 60 mm



## Technical Data Suction-Cup Balance SSCB

Type*	Material workpiece support	Suction cup type	Size	Material	Suction force [N]**	Pull-off force [N]**	Weight [g]
SSCB-78 141-171 EP M6-IG FSG-VU1	NBR	FSG	60	VU1	61	100	2,598
SSCB-78 141-171 ZP M6-IG FSG-VU1	NBR	FSG	60	VU1	61	100	2,610
SSCB-78 93.5-107.5 ZP 60 SAB-NBR	NBR	SAB	60	NBR	82	130	1,300

\*Technical data and design data are max. values, actual values depend on application probably. We recommend that before handling, you would better test every kind of workpiece. This is the only way to guarantee a safe handling process.

\*\*Specifications are theoretical values at a -0.6 bar vacuum on dry, flat and even workpiece surfaces – they do not include safety factors.

\*\*\*Specifications are theoretical values at a -0.6 bar vacuum on dry, flat and even workpiece surfaces – they do not include safety factors.



## Design Data Suction-Cup Balance SSCB

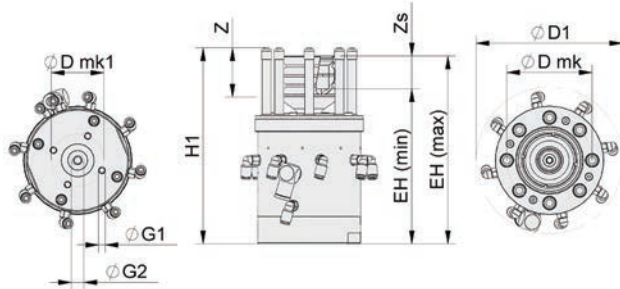

SSCB EP

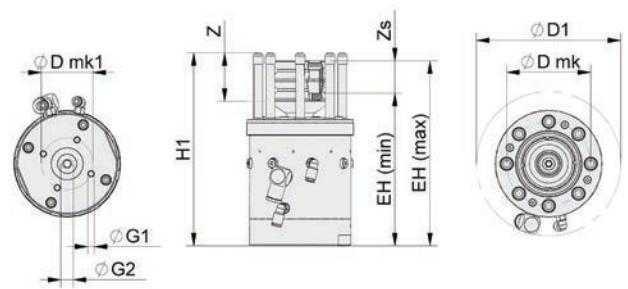

SSCB ZP

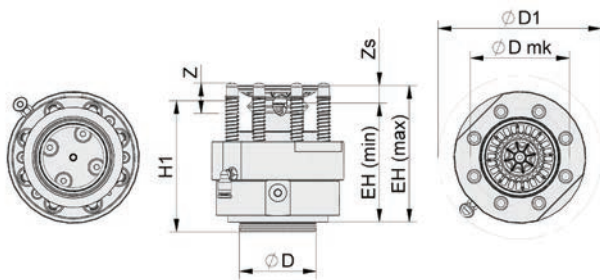

SSCB SAB

Type	D [mm]	D1 [mm]	Dmk [mm]	D mk1 [mm]	EH (max) [mm]	EH (min) [mm]	G1	G2	H1 [mm]	Zs [mm]	Z (Stroke) [mm]
SSCB-78 141-171 EP M6-IG FSG-VU1	-	134	78	48	171	141	M6-F	G1/4"-F	179	30	46
SSCB-78 141-171 ZP M6-IG FSG-VU1	-	134	78	48	171	141	M6-F	G1/4"-F	179	30	46
SSCB-78 93.5-107.5 ZP 60 SAB-NBR	60	117	78	-	108	94	-	-	118	14	22



- Schmalz – The Company
- Vacuum Suction Cups
- Special Grippers
- Gripping Systems**
- Clamping Systems
- Mounting Elements
- Vacuum Generators
- Valve Technology
- Switches and Monitoring
- Filters and Connections
- Services
- Contact
- Glossary
- Index of Products

# Vacuum Area Gripping Systems and Vacuum End Effectors





**Selection Aid**

Page



**Selection Aid Area Gripping Systems FXP / FMP**

291

**Selection Aid Area Gripping Systems SBX-C**

318

**Area Gripping Systems**

	<p><b>Area Gripping Systems FXP</b></p> <ul style="list-style-type: none"> <li>• Integrated vacuum generator (ejector)</li> <li>• Sealing element: Sealing foam or suction cups</li> </ul>		<p>Area gripping system FXP with a plug-in ejector for vacuum generation; high volume flow for porous workpieces.</p>	<p>296</p>
	<p><b>Area Gripping Systems FMP</b></p> <ul style="list-style-type: none"> <li>• Connection for external vacuum generation</li> <li>• Sealing element: Sealing foam or suction cups</li> </ul>		<p>Area gripping system FMP for external vacuum generators for handling workpieces of various qualities.</p>	<p>303</p>
	<p><b>Area Gripping Systems FMHD</b></p> <ul style="list-style-type: none"> <li>• Connection for external vacuum generation</li> <li>• Sealing element: Sealing foam</li> </ul>		<p>Robust gripping system with integrated reservoir for external vacuum generation; for workpieces with rough surfaces.</p>	<p>311</p>
	<p><b>Area Gripping Systems FX-SW</b></p> <ul style="list-style-type: none"> <li>• Integrated vacuum generator (ejector)</li> <li>• Sealing element: Sealing foam or suction cups</li> </ul>		<p>Small flexible universal gripper with integrated vacuum generator for handling workpieces of various types.</p>	<p>312</p>

Schmalz – The Company  
 Vacuum Suction Cups  
 Special Grippers  
 Gripping Systems  
 Clamping Systems  
 Mounting Elements  
 Vacuum Generators  
 Valve Technology  
 Switches and Monitoring  
 Filters and Connections  
 Services  
 Contact  
 Glossary  
 Index of Products

# Overview of Section

## At a Glance

Schmalz – The Company

Vacuum Suction Cups

Special Grippers

Gripping Systems

Clamping Systems

Mounting Elements

Vacuum Generators

Valve Technology

Switches and Monitoring

Filters and Connections

Services

Contact

Glossary

Index of Products

			Page
		<b>Area Gripping Systems FM-SW</b> <ul style="list-style-type: none"> <li>• Connection for external vacuum generation</li> <li>• Sealing element: Sealing foam or suction cups</li> </ul>	315
		<b>Area Gripping Systems SBX-C with Ejector</b> <ul style="list-style-type: none"> <li>• Integrated vacuum generator (ejector)</li> <li>• Sealing element: Sealing foam</li> </ul>	320
		<b>Area Gripping Systems SBX-C without Ejector</b> <ul style="list-style-type: none"> <li>• Connection for external vacuum generation</li> <li>• Sealing element: Sealing foam</li> </ul>	323

## Vacuum Layer Gripping Systems and Suction Spiders

		<b>Vacuum Layer Gripping Systems SPZ</b> <ul style="list-style-type: none"> <li>• Layer gripping systems are designed individually for your application.</li> </ul>	326
		<b>Suction Spiders SSP</b> <ul style="list-style-type: none"> <li>• Vacuum suction spiders are designed individually for your application.</li> </ul>	327

## Vacuum End Effectors

		<b>Vacuum End Effectors VEE</b> <ul style="list-style-type: none"> <li>• Dimensions: 38 x 38 to 300 x 200 mm</li> <li>• Sealing element: suction cups</li> </ul>	328
--	--	------------------------------------------------------------------------------------------------------------------------------------------------------------------	-----

## Overview



Vacuum gripping systems FXP and FMP with sealing foam and suction cups

## Application

- Universal gripper for handling workpieces regardless of size, geometry, material and surface
- Handling of workpieces made from various materials, such as wood (coated or unplanned), packaging (boxes, bags or cans), metal sheets, glass, plastics, CFRP etc.
- Handling of porous workpieces and workpieces with gaps
- Handling of workpieces with an undefined pick-up position
- Ideal for use on robots due to its low weight

## Design

### FXP: Integrated Vacuum Generation

As a unit that is ready for connection, the area gripping system FXP is equipped with a plug-in ejector for vacuum generation. With comparatively low maximum vacuum, the ejector generates a high volume flow and thus provides high holding forces, especially for applications with porous workpieces.

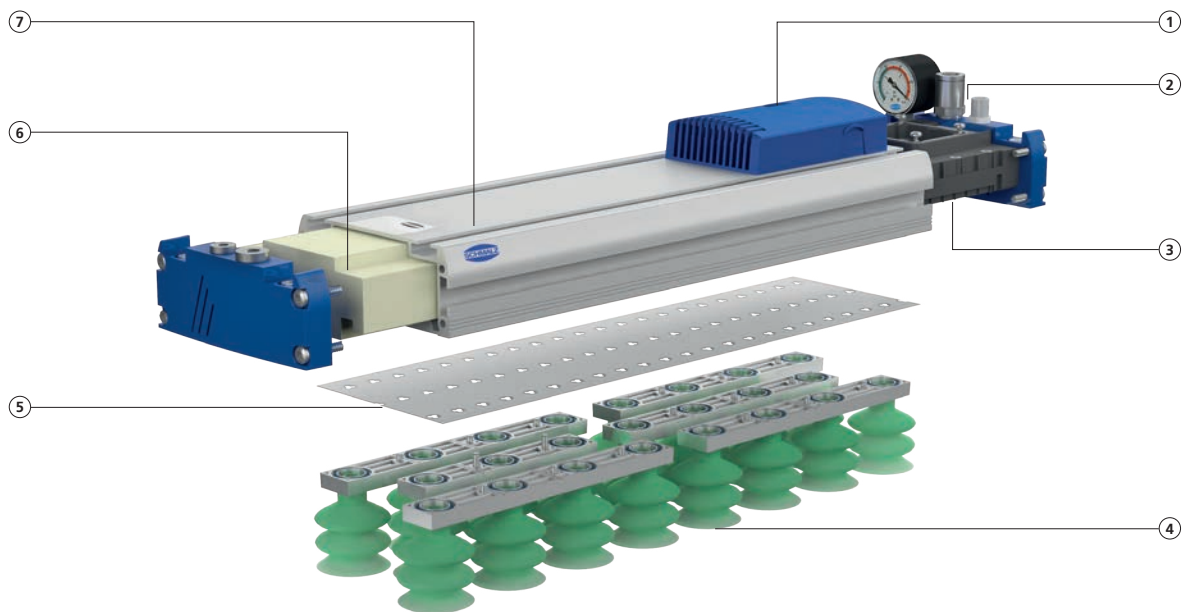

- ① **Silencer**
- Reduces the sound level to 74 dB(A)

- ② **End cover with integrated functions**
- Compressed air connection, vacuum gauge as well as optional vacuum switch and control valve

- ③ **Plug-in ejector**
- Fast evacuation and high suction flow even at low vacuum values

- ④ **Sealing elements**
- Figure shows suction cups with push-in function
  - Also available with sealing foam with optimized adhesive film

- ⑤ **Valve film**
- For quickly changing the valve type and size
  - Self-cleaning effect

- ⑥ **Vacuum booster**
- Faster evacuation due to reduced inner volume
  - Maximum power is reached instantly

- ⑦ **Aluminum base section**
- High stiffness and low weight
  - Lateral T-slots for fixation of sensors
  - Integrated air duct for separation
  - Variable gripper length possible

# Selection Aid Area Gripping Systems FXP / FMP

## Overview

### FMP: External Vacuum Generation

The area gripping system FMP is equipped with a connection piece for external vacuum generators and is therefore suitable for use in combination with powerful pumps and blowers.

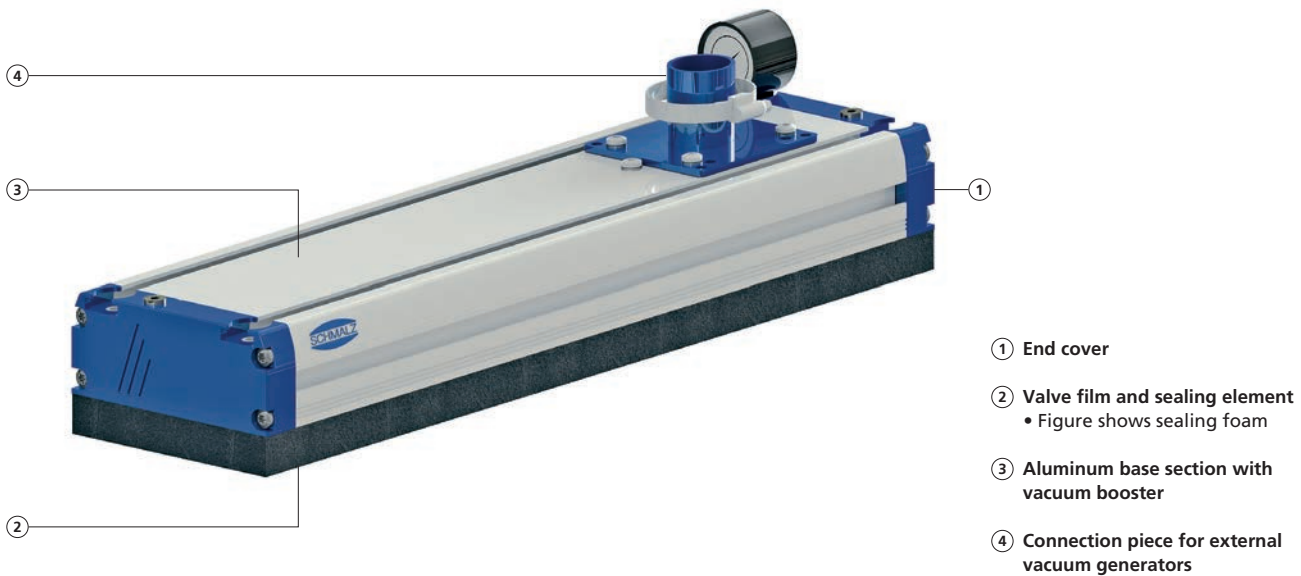

- ① End cover
- ② Valve film and sealing element  
• Figure shows sealing foam
- ③ Aluminum base section with vacuum booster
- ④ Connection piece for external vacuum generators

## Selection Aid

### Application features

	FXP	FMP
Minimization of interfering edges caused by hoses and attached vacuum generator (integration of functions)	✓	
Easy mounting and quick connection of the gripper	✓	
Minimal system costs (investment costs including vacuum generation, hoses and controller)	✓	
Minimal operating costs (because of the option of electrical vacuum generation), especially for applications with multiple grippers		✓
Handling of highly porous workpieces		✓

## Your Benefits

- 86 % More Power**  
 In a benchmark test, the FXP/FMP generates an 86 % higher suction force on average than comparable grippers on the market
- Unique Flexibility**  
 Handling of workpieces wider than 20 mm, regardless of material, geometry, surface and position
- Low Weight**  
 Maximum acceleration within the process and reducing system costs by use of smaller robots

- Minimal Maintenance**  
 Easy retooling of flow technology and fast replacement of sealing elements

- High Energy Efficiency**  
 Optimization of the flow ensures that energy is used more efficiently, which permanently reduces operating costs

- Low Sound Level**  
 Operation with a sound level of only 74 dB(A)



Valve type and size can be changed easily and quickly in case of changing requirements

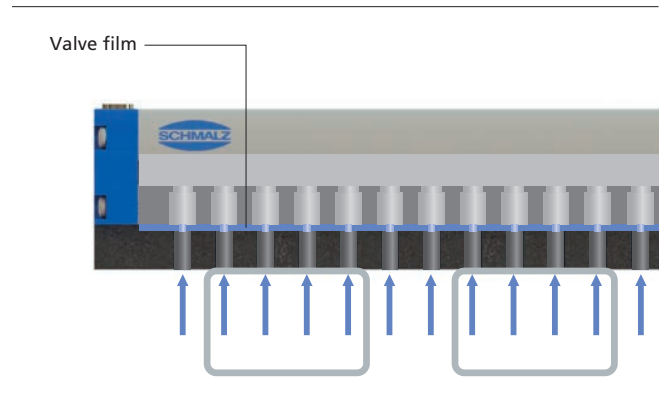
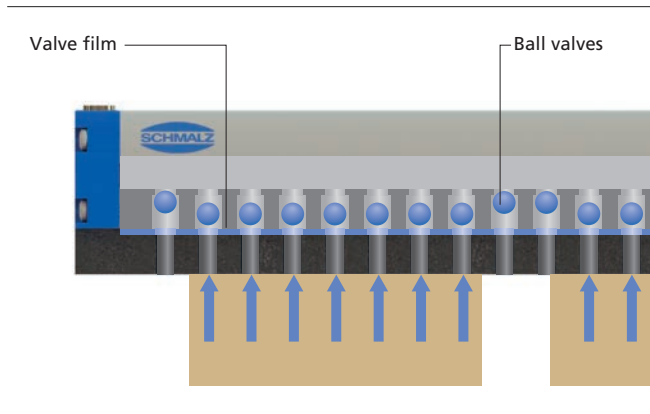

### Check Valves SVK

- Ball valves integrated in the base section for closing off uncovered suction cells
- Integrated leak-free, resulting in a higher vacuum as well as improved energy efficiency and holding force
- Valve film with clover shape for high flow rate and quick picking up and blowing off
- Proper functioning ensured even with unplaned surfaces

### Flow Restrictors SW

- Valve film with integrated flow restrictors to minimize leakage losses due to uncovered suction cells
- Suitable for swiveling operations and high accelerations
- Different flow diameters available (optional)

## Selection Aid

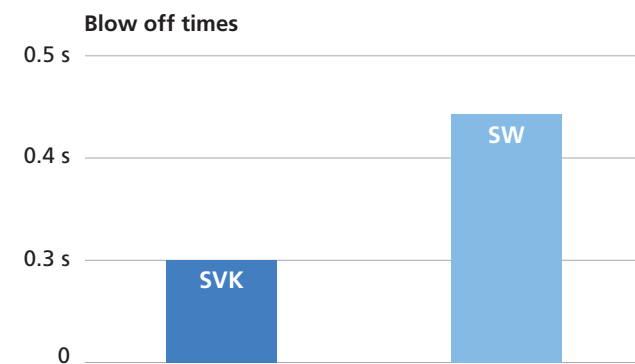

The higher nominal flow of the SVK valve type allows it to achieve significantly shorter blow off times than the SW type can (values in fig. measured at a gripper length of 442 mm)

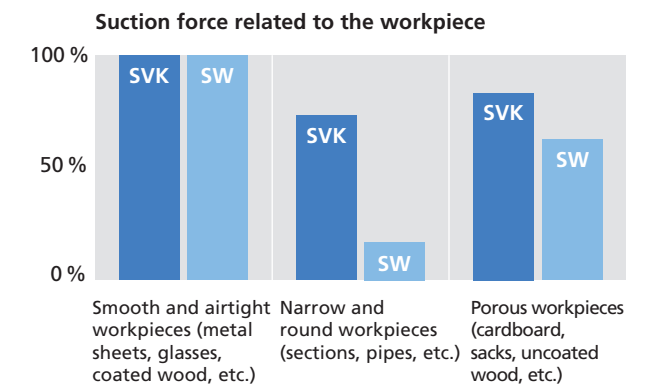

The valve type SVK achieves a higher suction force than the SW in case of porous workpieces and low degree of gripper coverage

Application features	SVK	SW
Smooth and airtight workpieces (e.g. metal sheets, glass, coated wood)	✓	✓
Porous workpieces (e.g. boxes, sacks, uncoated wood)	✓	
Structured surfaces	✓	
Workpieces with low gripper coverage (e.g. pipes, sections)	✓	
Minimum cycle times (active blow off)	✓	
Optimization of energy efficiency	✓	
Swiveling movements > 45°		✓



Schmalz – The Company  
Vacuum Suction Cups  
Special Grippers  
Gripping Systems  
Clamping Systems  
Mounting Elements  
Vacuum Generators  
Valve Technology  
Switches and Monitoring  
Filters and Connections  
Services  
Contact  
Glossary  
Index of Products

# Selection Aid Area Gripping Systems FXP / FMP

Flexible, Quick-Change Sealing Elements



Sealing foam and suction cups can be changed quickly and easily due to the adhesive film and the push-in function

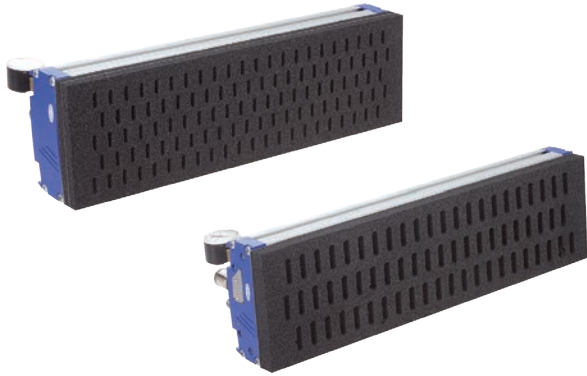

### Sealing Foam with Quick-Change Adhesive Film

- Optimal adjustment capabilities
- Quick rebound for short cycle times
- Replaceable without adhesive residue and without the need to clean the sheet
- Intended for workpieces wider than 20 mm (in the design with 5 suction rows, on request)
- With optional filter mat

### Suction Cups with Push-in Function

- Optimal height compensation and damping effect
- Quick replacement due to the push-in mechanism
- Diameters 20 mm and 40 mm
- Made from FDA compliant silicone
- With optional insert filter

## Selection Aid

Application features	Sealing foam	Suction cups
Rigid workpieces such as sheets, metal sheets, boards, sections and pallets	✓	
Flexible workpieces such as cardboard boxes, sacks, bags and trays		✓
Elongated workpieces such as strips, sections, boards	✓	
Workpieces with rough and structured surface	✓	
Handling of smaller product layers such as jars (open or closed) and cans with a continuous edge	✓	

## Additional Functions, Compactly Integrated



### End Cover with Integrated Functions

Minimization of system costs and installation times through integration of:

- Compressed air connection for ejector supply (type FXP)
- Control valves for switching the suction and blow off functions on/off (optional for type FXP-S)
- Connection for the blow off and separation functions
- Option to attach a vacuum gauge or vacuum switch



Schmalz - The Company  
Vacuum Suction Cups  
Special Grippers  
Gripping Systems  
Clamping Systems  
Mounting Elements  
Vacuum Generators  
Valve Technology  
Switches and Monitoring  
Filters and Connections  
Services  
Contact  
Glossary  
Index of Products

## Accessories



### Vacuum Switch

- Detection of the required vacuum and start of cycle by part present signal
- Optimization of cycle times
- Part no. 10.01.38.02485

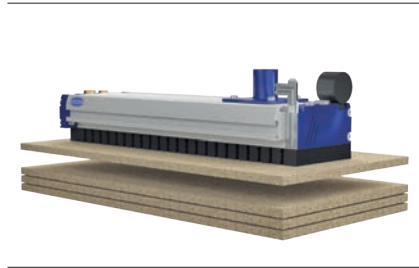

### Separation Function

- Separation of porous workpieces (e.g. boxes, MDF/particle boards) during destacking
- Active initiation of an adjustable, targeted compressed air pulse
- Part no. on request

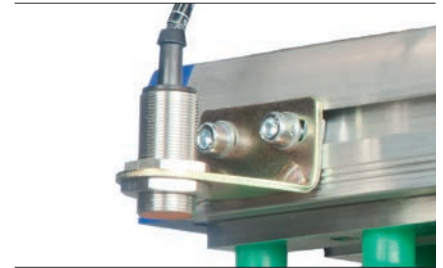

### Sensor Kit

- For workpiece and position detection
- Optimization of cycle times and increase in process reliability
- Includes attachment bracket
- Part no. on request



### Attachment Kit Sliding Block

- 4 sliding blocks
- 4 screws (M8x16)
- Part no. 10.01.21.00243



### Attachment Kit Flange Plate

- 1 flange plate
- Includes sliding block attachment kit
- Part no. 10.01.21.01291



### Attachment Kit Double Flange Plate

- 1 double flange plate
- Includes sliding block attachment kit
- Part no. 10.01.21.00244



### Attachment Kit Spring-Loaded Level Compensation

- 1 spring plunger (50 mm stroke) with jointed mounting
- Includes flange plate attachment kit
- Part no. 10.01.21.02407



### Attachment Kit Flexible Level Compensation

- 1 spring plunger (50 mm stroke) with spherical bearing
- Maximum flexibility for uneven workpieces
- Self-centering and therefore no jamming
- Part no. on request



### Cover Strip for T-Slots

- Positive-locking cover for the T-slots
- Easy cleaning
- Cable duct possible
- Available by the meter
- Part no. 26.07.03.00002

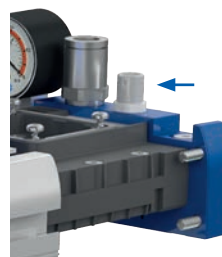

### Integrated Control Valves (for Type FXP-S)

- For switching vacuum and blow off on/off
- Minimum suction and blow off times
- Electrical connection via M12 plug (4-pole)
- Part no. on request



### Solenoid Valve (for FMP Type)

- For switching blow off on/off
- Fast evacuation and minimization of cycle times
- Can be flange mounted on the gripper
- Part no. 10.01.21.02405



Tests with the original workpieces are necessary to ensure that the area gripping system functions properly. We will gladly conduct these for you in our test center in order to find the best solution for your application.



# Area Gripping Systems FXP

Suction area (LxW) from 442 x 130 mm to 1,432 x 130 mm



## Suitability for Industry Specific Applications

### Applications

- Universal gripper with integrated, pneumatic vacuum generation, for handling workpieces regardless of size, geometry, material and surface
- Handling of workpieces made from various materials, such as wood (coated or unplanned), packaging (boxes, bags or cans), metal sheets, glass, plastics, CFRP, etc.
- Handling of porous workpieces, workpieces with gaps or undefined pick-up position
- Mark-free handling of sensitive workpieces such as display glass
- Ideal for use on robots due to its low weight

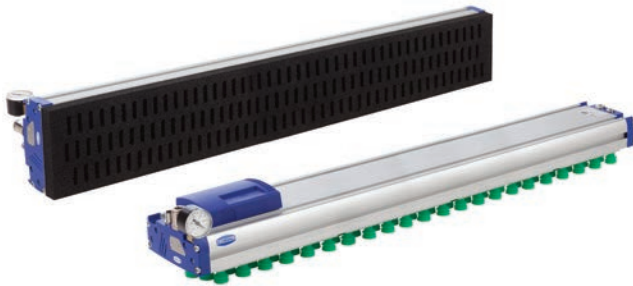

Area Gripping Systems FXP

### Design

- Aluminum basic profile (1) with side T-slots for sensors and an integrated air supply for separation; different gripper lengths available
- Vacuum booster (2) for quicker evacuation; valve film (3) for the quick change of valve type and size
- Suction cup sealing element (4) with push-in function or sealing foam with adhesive film
- Multi-stage ejector (5) as integrated vacuum generator
- End cover with integrated functions (6): connection for compressed air, vacuum gauges; optional vacuum switches and control valves
- Silencer (7)

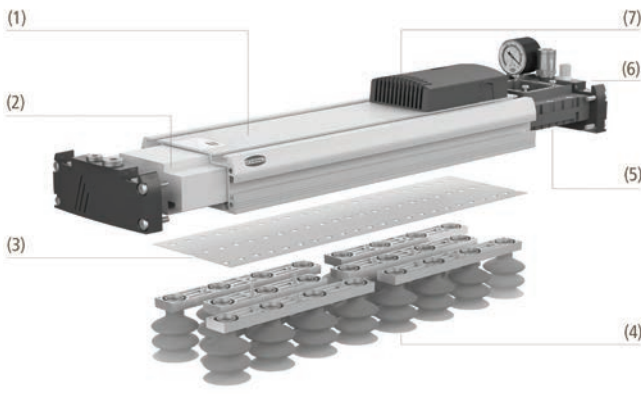

System Design Area Gripping Systems FXP

### Our Highlights...

- Integrated vacuum generator (multi-stage ejector)
- Integrated vacuum booster in the basic profile
- Choice of suction cups or sealing foam as the sealing element
- Choice of valve type and size

### Your Benefits...

- Rapid vacuum build-up for short cycles; minimum interference contours
- Rapid evacuation for short cycles
- Gripper optimally adapted to the application
- Check valve (SVK): porous workpieces; flow restrictors (SW): smooth surfaces, swiveling processes greater than 45°

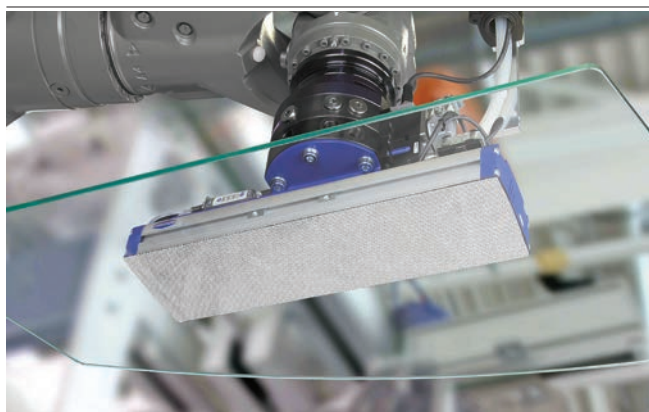

Area Gripping System FXP with protective layer SU for handling glass



Schmalz – The Company  
Vacuum Suction Cups  
Special Grippers  
Gripping Systems  
Clamping Systems  
Mounting Elements  
Vacuum Generators  
Valve Technology  
Switches and Monitoring  
Filters and Connections  
Services  
Contact  
Glossary  
Index of Products



# Area Gripping Systems FXP

Suction area (LxW) from 442 x 130 mm to 1,432 x 130 mm

## Designation Code Area Gripping Systems FXP



### 1 – Abbreviated designation

Code	Version
FXP	Integrated vacuum generator

### 2 – Control valve

Code	Type
S	Integrated control valves
-	No control valves

### 3 – Valve technology

Code	Type
SW	Flow restrictor
SVK	Check valve

### 4 – Length

Code	Length in mm
442	442
640	640
838	838
1234	1234
1432	1432

### 5 – Suction rows

Code	Number
3R	3 suction rows
5R	5 suction rows

### 6 – Hole spacing

Code	Spacing in mm
18	18
36	36
54	54

### 7 – Sealing element

Code	Height/diameter in mm
O20	Sealing foam (height = 20)
O10O10	Sealing foam (height = 20)
N10	Sealing foam (height = 10)
SPB2-20 P	Suction cup (ø 20)
SPB2-40 P	Suction cup (ø 40)

### 8 – Protective layer

Code	Type
SU	Protective layer
-	No protective layer

### 9 – Filter

Code	Type
F	Filter
-	No filter

- Integrated control valves at FXP-S (optional)
- Control of vacuum on/off (24V DC, normally open) and blow off on/off (24V DC, normally closed) on version FXP-S
- Integrated in the end cover
- Electrical connection: M12 plug (4-pole)

Available spare parts: sealing foam (DI-PL), suction cup (SPB2)

## Ordering Data Area Gripping Systems FXP

Type (Sealing foam)				Length L [mm]:				
				442	640	838	1234	1432
FXP-SW	3R18	O20	-	10.01.38.00685	10.01.38.00686	10.01.38.00687	10.01.38.00688	10.01.38.00689
FXP-SW	3R18	O10O10	F	10.01.38.00690	10.01.38.00691	10.01.38.00692	10.01.38.00693	10.01.38.00694
FXP-SW	5R18	O10O10	-	10.01.38.00705	10.01.38.00706	10.01.38.00707	10.01.38.00708	10.01.38.00709
FXP-SW	5R18	O10O10	F	10.01.38.00710	10.01.38.00711	10.01.38.00712	10.01.38.00713	10.01.38.00714
FXP-SW	5R18	N10SU	-	10.01.38.02947	10.01.38.02948	10.01.38.02949	10.01.38.02950	10.01.38.02951
FXP-S-SW	3R18	O20	-	10.01.38.00908	10.01.38.00909	10.01.38.00910	10.01.38.00911	10.01.38.00912
FXP-S-SW	3R18	O10O10	F	10.01.38.00913	10.01.38.00914	10.01.38.00915	10.01.38.00916	10.01.38.00917
FXP-S-SW	5R18	O10O10	-	10.01.38.00928	10.01.38.00929	10.01.38.00930	10.01.38.00931	10.01.38.00932
FXP-S-SW	5R18	O10O10	F	10.01.38.00933	10.01.38.00934	10.01.38.00935	10.01.38.00936	10.01.38.00937
FXP-S-SW	5R18	N10SU	-	10.01.38.02957	10.01.38.02958	10.01.38.02959	10.01.38.02960	10.01.38.02961



Schmalz – The Company  
Vacuum Suction Cups  
Special Grippers  
Gripping Systems  
Clamping Systems  
Mounting Elements  
Vacuum Generators  
Valve Technology  
Switches and Monitoring  
Filters and Connections  
Services  
Contact  
Glossary  
Index of Products

# Area Gripping Systems FXP

Suction area (LxW) from 442 x 130 mm to 1,432 x 130 mm



## Ordering Data Area Gripping Systems FXP

Type (Sealing foam)				Length L [mm]:				
				442	640	838	1234	1432
FXP-SVK	3R18	O20	-	10.01.38.00675	10.01.38.00676	10.01.38.00677	10.01.38.00678	10.01.38.00679
FXP-SVK	3R18	O10O10	F	10.01.38.00680	10.01.38.00681	10.01.38.00682	10.01.38.00683	10.01.38.00684
FXP-SVK	5R18	O10O10	-	10.01.38.00695	10.01.38.00696	10.01.38.00697	10.01.38.00698	10.01.38.00699
FXP-SVK	5R18	O10O10	F	10.01.38.00700	10.01.38.00701	10.01.38.00702	10.01.38.00703	10.01.38.00704
FXP-SVK	5R18	N10SU	-	10.01.38.02952	10.01.38.02953	10.01.38.02954	10.01.38.02955	10.01.38.02956
FXP-S-SVK	3R18	O20	-	10.01.38.00876	10.01.38.00899	10.01.38.00900	10.01.38.00901	10.01.38.00902
FXP-S-SVK	3R18	O10O10	F	10.01.38.00903	10.01.38.00904	10.01.38.00905	10.01.38.00906	10.01.38.00907
FXP-S-SVK	5R18	O10O10	-	10.01.38.00918	10.01.38.00919	10.01.38.00920	10.01.38.00921	10.01.38.00922
FXP-S-SVK	5R18	O10O10	F	10.01.38.00923	10.01.38.00924	10.01.38.00925	10.01.38.00926	10.01.38.00927
FXP-S-SVK	5R18	N10SU	-	10.01.38.02962	10.01.38.02963	10.01.38.02964	10.01.38.02965	10.01.38.02966

Type (Suction cup)				Length L [mm]:					
				442	640	838	1234	1432	
FXP-SW	5R36	SPB2	20	-	10.01.38.00745	10.01.38.00746	10.01.38.00747	10.01.38.00748	10.01.38.00749
FXP-SW	5R36	SPB2	20	F	10.01.38.00750	10.01.38.00751	10.01.38.00752	10.01.38.00753	10.01.38.00754
FXP-SW	3R54	SPB2	40	-	10.01.38.00725	10.01.38.00726	10.01.38.00727	10.01.38.00728	10.01.38.00729
FXP-SW	3R54	SPB2	40	F	10.01.38.00730	10.01.38.00731	10.01.38.00732	10.01.38.00733	10.01.38.00734
FXP-S-SW	5R36	SPB2	20	-	10.01.38.00968	10.01.38.00969	10.01.38.00970	10.01.38.00971	10.01.38.00972
FXP-S-SW	5R36	SPB2	20	F	10.01.38.00973	10.01.38.00974	10.01.38.00975	10.01.38.00976	10.01.38.00977
FXP-S-SW	3R54	SPB2	40	-	10.01.38.00948	10.01.38.00949	10.01.38.00950	10.01.38.00951	10.01.38.00952
FXP-S-SW	3R54	SPB2	40	F	10.01.38.00953	10.01.38.00954	10.01.38.00955	10.01.38.00956	10.01.38.00957

Type (Suction cup)				Length L [mm]:					
				442	640	838	1234	1432	
FXP-SVK	5R36	SPB2	20	-	10.01.38.00735	10.01.38.00736	10.01.38.00737	10.01.38.00738	10.01.38.00739
FXP-SVK	5R36	SPB2	20	F	10.01.38.00740	10.01.38.00741	10.01.38.00742	10.01.38.00743	10.01.38.00744
FXP-SVK	3R54	SPB2	40	-	10.01.38.00715	10.01.38.00716	10.01.38.00717	10.01.38.00718	10.01.38.00719
FXP-SVK	3R54	SPB2	40	F	10.01.38.00720	10.01.38.00721	10.01.38.00722	10.01.38.00723	10.01.38.00724
FXP-S-SVK	5R36	SPB2	20	-	10.01.38.00958	10.01.38.00959	10.01.38.00960	10.01.38.00961	10.01.38.00962
FXP-S-SVK	5R36	SPB2	20	F	10.01.38.00963	10.01.38.00964	10.01.38.00965	10.01.38.00966	10.01.38.00967
FXP-S-SVK	3R54	SPB2	40	-	10.01.38.00938	10.01.38.00939	10.01.38.00940	10.01.38.00941	10.01.38.00942
FXP-S-SVK	3R54	SPB2	40	F	10.01.38.00943	10.01.38.00944	10.01.38.00945	10.01.38.00946	10.01.38.00947



## Ordering Data Spare Parts Area Gripping Systems FXP

Type (Sealing foam)			3R18	3R18 F	5R18	5R18 F
DI-PL	442	O20	10.01.38.00113	-	-	-
DI-PL	442	O10O10	-	10.01.38.00192	10.01.38.00864	10.01.38.00622
DI-PL	442	N10SU	-	-	10.01.38.02863	-
DI-PL	640	O20	10.01.38.00405	-	-	-
DI-PL	640	O10O10	-	10.01.38.00408	10.01.38.00865	10.01.38.00627
DI-PL	640	N10SU	-	-	10.01.38.02864	-



Schmalz - The Company  
Vacuum Suction Cups  
Special Grippers  
Gripping Systems  
Clamping Systems  
Mounting Elements  
Vacuum Generators  
Valve Technology  
Switches and Monitoring  
Filters and Connections  
Services  
Contact  
Glossary  
Index of Products

# Area Gripping Systems FXP

Suction area (LxW) from 442 x 130 mm to 1,432 x 130 mm



## Ordering Data Spare Parts Area Gripping Systems FXP

Type (Sealing foam)			3R18	3R18 F	5R18	5R18 F
DI-PL	838	O20	10.01.38.00140	-	-	-
DI-PL	838	O10O10	-	10.01.38.00409	10.01.38.00866	10.01.38.00628
DI-PL	838	N10SU	-	-	10.01.38.02865	-
DI-PL	1234	O20	10.01.38.00193	-	-	-
DI-PL	1234	O10O10	-	10.01.38.00196	10.01.38.00867	10.01.38.00629
DI-PL	1,234	N10SU	-	-	10.01.38.02866	-
DI-PL	1432	O20	10.01.38.00406	-	-	-
DI-PL	1432	O10O10	-	10.01.38.00410	10.01.38.00868	10.01.38.00630
DI-PL	1432	N10SU	-	-	10.01.38.02867	-

Type (Suction cup)				Spare Parts	Part no.
FXP	5R36	SPB2	-	Bellows suction cup (round)	SPB2 20 10.01.06.03125
FXP	5R36	SPB2	F	Bellows suction cup (round)	SPB2 20 F 10.01.38.00465
FXP	3R54	SPB2	-	Bellows suction cup (round)	SPB2 40 10.01.06.03126
FXP	3R54	SPB2	F	Bellows suction cup (round)	SPB2 40 F 10.01.38.00452



## Technical Data Area Gripping Systems FXP

Type (Sealing foam)*				Number of suction cells	Air consumption [l/min]**	Suction rate max. [l/min]	Suction force [N]***	Weight [kg]
FXP-SW	442	3R18	O20	66	250	1,050	440	2.1
FXP-SW	640	3R18	O20	99	375	1,350	660	2.9
FXP-SW	838	3R18	O20	132	500	1,600	870	3.7
FXP-SW	1234	3R18	O20	198	875	2,940	1,310	5.2
FXP-SW	1432	3R18	O20	231	1,000	3,180	1,530	5.8
FXP-SW	442	3R18	O10O10	66	250	1,050	440	2.1
FXP-SW	640	3R18	O10O10	99	375	1,350	660	2.9
FXP-SW	838	3R18	O10O10	132	500	1,600	870	3.7
FXP-SW	1234	3R18	O10O10	198	875	2,940	1,310	5.2
FXP-SW	1432	3R18	O10O10	231	1,000	3,180	1,530	5.8
FXP-SW	442	5R18	O10O10	110	250	1,050	340	2.1
FXP-SW	640	5R18	O10O10	165	375	1,350	510	2.9
FXP-SW	838	5R18	O10O10	220	500	1,600	670	3.7
FXP-SW	1234	5R18	O10O10	330	875	2,940	1,010	5.2
FXP-SW	1432	5R18	O10O10	385	1,000	3,180	1,180	5.8
FXP-SW	442	5R18	N10SU	110	250	1,050	340	2.5
FXP-SW	640	5R18	N10SU	165	375	1,350	510	2.5
FXP-SW	838	5R18	N10SU	220	500	1,600	670	4.1
FXP-SW	1234	5R18	N10SU	330	875	2,940	1,010	5.6
FXP-SW	1432	5R18	N10SU	385	1,000	3,180	1,180	6.2
FXP-S-SW	442	3R18	O20	66	250	1,050	440	2.7
FXP-S-SW	640	3R18	O20	99	375	1,350	660	3.5
FXP-S-SW	838	3R18	O20	132	500	1,600	870	4.3
FXP-S-SW	1234	3R18	O20	198	875	2,940	1,310	6.0

Schmalz – The Company  
Vacuum Suction Cups  
Special Grippers  
Gripping Systems  
Clamping Systems  
Mounting Elements  
Vacuum Generators  
Valve Technology  
Switches and Monitoring  
Filters and Connections  
Services  
Contact  
Glossary  
Index of Products

# Area Gripping Systems FXP

Suction area (LxW) from 442 x 130 mm to 1,432 x 130 mm

## Technical Data Area Gripping Systems FXP

Type (Sealing foam)*				Number of suction cells	Air consumption [l/min]**	Suction rate max. [l/min]	Suction force [N]***	Weight [kg]
FXP-S-SW	1432	3R18	O20	231	1,000	3,180	1,530	6.6
FXP-S-SW	442	5R18	O10O10	66	250	1,050	440	2.7
FXP-S-SW	640	5R18	O10O10	99	375	1,350	660	3.5
FXP-S-SW	838	5R18	O10O10	132	500	1,600	870	4.3
FXP-S-SW	1234	5R18	O10O10	198	875	2,940	1,310	6.0
FXP-S-SW	1432	5R18	O10O10	231	1,000	3,180	1,530	6.6

\*Sound level 74 dB(A)

\*\*For compressed air with 5.5 bar input pressure

\*\*\*At -0.25 bar and with the gripper fully covered by a workpiece typical for the application (cardboard bulging with structured surface)

Type (Sealing foam)*				Number of suction cells	Air consumption [l/min]**	Suction rate max. [l/min]	Suction force [N]***	Weight [kg]
FXP-SVK	442	3R18	O20	66	250	1,050	550	2.2
FXP-SVK	640	3R18	O20	99	375	1,350	820	3.0
FXP-SVK	838	3R18	O20	132	500	1,600	1,090	4.2
FXP-SVK	1234	3R18	O20	198	875	2,940	1,650	5.7
FXP-SVK	1432	3R18	O20	231	1,000	3,180	1,910	6.3
FXP-SVK	442	3R18	O10O10	66	250	1,050	550	2.2
FXP-SVK	640	3R18	O10O10	99	375	1,350	820	3.4
FXP-SVK	838	3R18	O10O10	132	500	1,600	1,090	4.2
FXP-SVK	1234	3R18	O10O10	198	875	2,940	1,650	5.7
FXP-SVK	1432	3R18	O10O10	231	1,000	3,180	1,910	6.3
FXP-SVK	442	5R18	O10O10	110	250	1,050	430	2.2
FXP-SVK	640	5R18	O10O10	165	375	1,350	630	3.0
FXP-SVK	838	5R18	O10O10	220	500	1,600	840	3.8
FXP-SVK	1234	5R18	O10O10	330	875	2,940	1,270	5.3
FXP-SVK	1432	5R18	O10O10	385	1,000	3,180	1,470	5.9
FXP-SVK	442	5R18	N10SU	110	250	1,050	430	2.6
FXP-SVK	640	5R18	N10SU	165	375	1,350	630	3.4
FXP-SVK	838	5R18	N10SU	220	500	1,600	840	4.2
FXP-SVK	1234	5R18	N10SU	330	875	2,940	1,270	5.7
FXP-SVK	1432	5R18	N10SU	385	1,000	3,180	1,470	6.3
FXP-S-SVK	442	3R18	O20	66	250	1,050	550	2.8
FXP-S-SVK	640	3R18	O20	99	375	1,350	820	3.6
FXP-S-SVK	838	3R18	O20	132	500	1,600	1,090	4.4
FXP-S-SVK	1234	3R18	O20	198	875	2,940	1,650	6.1
FXP-S-SVK	1432	3R18	O20	231	1,000	3,180	1,910	6.7
FXP-S-SVK	442	5R18	O10O10	110	250	1,050	430	2.8
FXP-S-SVK	640	5R18	O10O10	165	375	1,350	630	3.6
FXP-S-SVK	838	5R18	O10O10	220	500	1,600	840	4.4
FXP-S-SVK	1234	5R18	O10O10	330	875	2,940	1,270	6.1
FXP-S-SVK	1432	5R18	O10O10	385	1,000	3,180	1,470	6.7

\*Sound level 74 dB(A)

\*\*For compressed air with 5.5 bar input pressure

\*\*\*At -0.25 bar and with the gripper fully covered by a workpiece typical for the application (cardboard bulging with structured surface)

Schmalz - The Company  
Vacuum Suction Cups  
Special Grippers  
Gripping Systems  
Clamping Systems  
Mounting Elements  
Vacuum Generators  
Valve Technology  
Switches and Monitoring  
Filters and Connections  
Services  
Contact  
Glossary  
Index of Products

# Area Gripping Systems FXP

Suction area (LxW) from 442 x 130 mm to 1,432 x 130 mm



## Technical Data Area Gripping Systems FXP

Type (Suction cup)*				Number of suction cells	Air consumption [l/min]**	Suction rate max. [l/min]	Suction force [N]***	Weight [kg]
FXP-SW	442	5R36	SPB2	55	250	1,050	140	2.6
FXP-SW	640	5R36	SPB2	82	375	1,350	210	3.6
FXP-SW	838	5R36	SPB2	110	500	1,600	280	4.4
FXP-SW	1234	5R36	SPB2	165	875	2,940	420	6.2
FXP-SW	1432	5R36	SPB2	193	1,000	3,180	490	7.0
FXP-SW	442	3R54	SPB2	23	250	1,050	200	2.7
FXP-SW	640	3R54	SPB2	33	375	1,350	290	3.7
FXP-SW	838	3R54	SPB2	44	500	1,600	390	4.6
FXP-SW	1234	3R54	SPB2	66	875	2,940	580	6.4
FXP-SW	1432	3R54	SPB2	77	1,000	3,180	680	7.2
FXP-S-SW	442	5R36	SPB2	55	250	1,050	140	3.5
FXP-S-SW	640	5R36	SPB2	82	375	1,350	210	4.6
FXP-S-SW	838	5R36	SPB2	110	500	1,600	280	5.6
FXP-S-SW	1234	5R36	SPB2	165	875	2,940	420	7.9
FXP-S-SW	1432	5R36	SPB2	193	1,000	3,180	490	8.8
FXP-S-SW	442	3R54	SPB2	23	250	1,050	200	3.2
FXP-S-SW	640	3R54	SPB2	33	375	1,350	290	4.3
FXP-S-SW	838	3R54	SPB2	44	500	1,600	390	5.3
FXP-S-SW	1234	3R54	SPB2	66	875	2,940	580	7.6
FXP-S-SW	1432	3R54	SPB2	77	1,000	3,180	680	8.5

\*Sound level 74 dB(A)

\*\*For compressed air with 5.5 bar input pressure

\*\*\*At -0.25 bar and with the gripper fully covered by a workpiece typical for the application (cardboard bulging with structured surface)

Type (Suction cup)*				Number of suction cells	Air consumption [l/min]**	Suction rate max. [l/min]	Suction force [N]***	Weight [kg]
FXP-SVK	442	5R36	SPB2	55	250	1,050	180	2.7
FXP-SVK	640	5R36	SPB2	82	375	1,350	270	3.7
FXP-SVK	838	5R36	SPB2	110	500	1,600	360	4.5
FXP-SVK	1234	5R36	SPB2	165	875	2,940	540	6.3
FXP-SVK	1432	5R36	SPB2	193	1,000	3,180	630	7.1
FXP-SVK	442	3R54	SPB2	23	250	1,050	250	2.8
FXP-SVK	640	3R54	SPB2	33	375	1,350	360	3.8
FXP-SVK	838	3R54	SPB2	44	500	1,600	480	4.7
FXP-SVK	1234	3R54	SPB2	66	875	2,940	720	6.5
FXP-SVK	1432	3R54	SPB2	77	1,000	3,180	840	7.3
FXP-S-SVK	442	5R36	SPB2	55	250	1,050	180	3.6
FXP-S-SVK	640	5R36	SPB2	82	375	1,350	270	4.7
FXP-S-SVK	838	5R36	SPB2	110	500	1,600	360	5.7
FXP-S-SVK	1234	5R36	SPB2	165	875	2,940	540	8.0
FXP-S-SVK	1432	5R36	SPB2	193	1,000	3,180	630	8.9
FXP-S-SVK	442	3R54	SPB2	23	250	1,050	250	3.3
FXP-S-SVK	640	3R54	SPB2	33	375	1,350	360	4.4
FXP-S-SVK	838	3R54	SPB2	44	500	1,600	480	5.4
FXP-S-SVK	1234	3R54	SPB2	66	875	2,940	720	7.7
FXP-S-SVK	1432	3R54	SPB2	77	1,000	3,180	840	8.6

\*Sound level 74 dB(A)

\*\*For compressed air with 5.5 bar input pressure

\*\*\*At -0.25 bar and with the gripper fully covered by a workpiece typical for the application (cardboard bulging with structured surface)



# Area Gripping Systems FXP

Suction area (LxW) from 442 x 130 mm to 1,432 x 130 mm



## Design Data Area Gripping Systems FXP

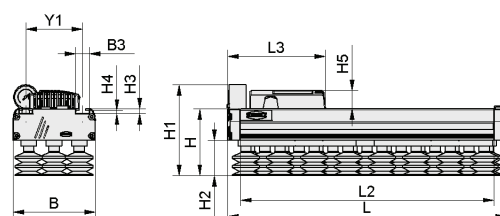
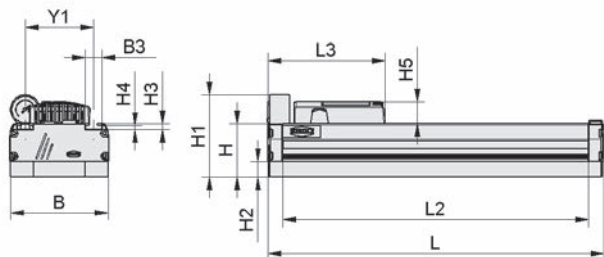

FXP O20, O10O10, N10SU

FXP SPB2

Type (Sealing foam)		B	B3	H	H1	H2	H3	H4	H5	L	L2	L3	Y1
		[mm]	[mm]	[mm]	[mm]	[mm]	[mm]	[mm]	[mm]	[mm]*	[mm]	[mm]	[mm]
FXP	3R18	130	22	70	109	20	7.7	5.5	28	442	402	154	90
FXP	3R18	130	22	70	109	20	7.7	5.5	28	640	600	154	90
FXP	3R18	130	22	70	109	20	7.7	5.5	28	838	798	154	90
FXP	3R18	130	22	70	109	20	7.7	5.5	28	1,234	1,194	154	90
FXP	3R18	130	22	70	109	20	7.7	5.5	28	1,432	1,392	154	90
FXP	5R18	130	22	70	109	20	7.7	5.5	28	442	402	154	90
FXP	5R18	130	22	70	109	20	7.7	5.5	28	640	600	154	90
FXP	5R18	130	22	70	109	20	7.7	5.5	28	838	798	154	90
FXP	5R18	130	22	70	109	20	7.7	5.5	28	1,234	1,194	154	90
FXP	5R18	130	22	70	109	20	7.7	5.5	28	1,432	1,392	154	90
FXP-S	3R18	130	22	70	109	20	7.7	5.5	28	442	402	154	90
FXP-S	3R18	130	22	70	109	20	7.7	5.5	28	640	600	154	90
FXP-S	3R18	130	22	70	109	20	7.7	5.5	28	838	798	154	90
FXP-S	3R18	130	22	70	109	20	7.7	5.5	28	1,234	1,194	154	90
FXP-S	3R18	130	22	70	109	20	7.7	5.5	28	1,432	1,392	154	90
FXP-S	5R18	130	22	70	109	20	7.7	5.5	28	442	402	154	90
FXP-S	5R18	130	22	70	109	20	7.7	5.5	28	640	600	154	90
FXP-S	5R18	130	22	70	109	20	7.7	5.5	28	838	798	154	90
FXP-S	5R18	130	22	70	109	20	7.7	5.5	28	1,234	1,194	154	90
FXP-S	5R18	130	22	70	109	20	7.7	5.5	28	1,432	1,392	154	90

\*Two ejectors/silencer box covers are used for the 1,234 mm and 1,432 mm length. Type FXP requires compressed air hose 12/9 mm.

Type (Suction cup)			B	B3	H	H1	H2	H3	H4	H5	L	L2	L3	Y1
			[mm]	[mm]	[mm]	[mm]	[mm]	[mm]	[mm]	[mm]	[mm]*	[mm]	[mm]	[mm]
FXP	5R36	SPB2	130	22	83	122	33	7.7	5.5	28	442	402	154	90
FXP	5R36	SPB2	130	22	83	122	33	7.7	5.5	28	640	600	154	90
FXP	5R36	SPB2	130	22	83	122	33	7.7	5.5	28	838	798	154	90
FXP	5R36	SPB2	130	22	83	122	33	7.7	5.5	28	1,234	1,194	154	90
FXP	5R36	SPB2	130	22	83	122	33	7.7	5.5	28	1,432	1,392	154	90
FXP	3R54	SPB2	130	22	105	144	55	7.7	5.5	28	442	402	154	90
FXP	3R54	SPB2	130	22	105	144	55	7.7	5.5	28	640	600	154	90
FXP	3R54	SPB2	130	22	105	144	55	7.7	5.5	28	838	798	154	90
FXP	3R54	SPB2	130	22	105	144	55	7.7	5.5	28	1,234	1,194	154	90
FXP	3R54	SPB2	130	22	105	144	55	7.7	5.5	28	1,432	1,392	154	90

\*Two ejectors/silencer box covers are used for the 1,234 mm and 1,432 mm length. Type FXP requires compressed air hose 12/9 mm.



# Area Gripping Systems FMP

Suction area (LxW) from 442 x 130 mm to 1,432 x 130 mm

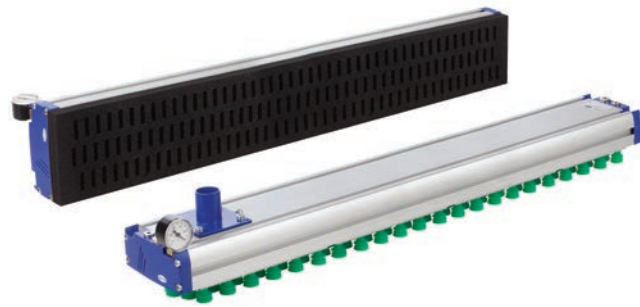

Area Gripping Systems FMP

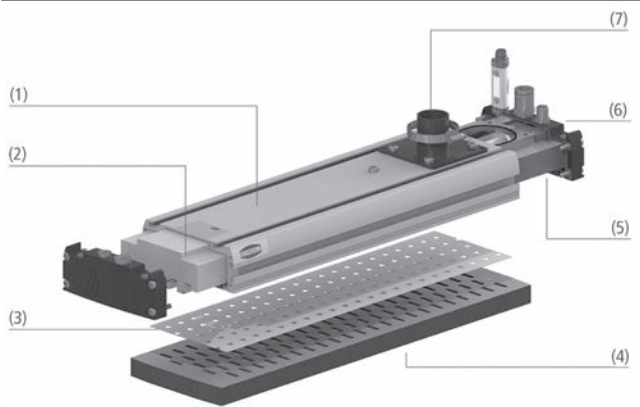

System Design Area Gripping Systems FMP



Area Gripping System FMP-S for layer-wise stacking of construction wood

## Suitability for Industry Specific Applications

### Applications

- Universal gripper with connection for external vacuum generation, for handling workpieces regardless of size, geometry, material and surface
- Handling of workpieces made from various materials, such as wood (coated or unplanned), packaging (boxes, bags or cans), metal sheets, glass, plastics, CFRP, etc.
- Handling of porous workpieces, workpieces with gaps or undefined pick-up position
- Mark-free handling of sensitive workpieces such as display glass
- Ideal for use on robots due to its low weight

### Design

- Aluminum basic profile (1) with side T-slots for sensors and integrated air supply for separation; different gripper lengths available
- Vacuum booster (2) for quicker evacuation; valve film (3) for quick change of valve type and size
- Suction cup sealing element (4) with push-in function or sealing foam with adhesive film
- Optional integrated withdrawable vacuum valve (5): fast evacuation and high suction volume
- End cover with integr. functions (6): connect. for compressed air, vacuum gauges; opt. vacuum switches and control valves
- Connecting piece (7) for external vacuum generation

### Our Highlights...

- Connection for electrical vacuum generators (blower or pump)
- Integrated vacuum booster in the basic profile
- Choice of suction cups or sealing foam as the sealing element
- Choice of valve type and size

### Your Benefits...

- High flow rates and vacuum up to -0.8 bar; low operating costs
- Rapid evacuation for short cycles
- Gripper optimally adapted to the application
- Check valve (SVK): porous workpieces; flow restrictors (SW): smooth surfaces, swiveling processes greater than 45°



# Area Gripping Systems FMP

Suction area (LxW) from 442 x 130 mm to 1,432 x 130 mm

## Designation Code Area Gripping Systems FMP



### 1 - Abbreviated designation

Code	Version
FMP	External vacuum generator

### 2 - Control valve

Code	Type
S	Integrated control valves
-	No control valves

### 3 - Valve technology

Code	Type
SW	Flow restrictor
SVK	Check valve

### 4 - Length

Code	Length in mm
442	442
640	640
838	838
1234	1234
1432	1432

### 5 - Suction rows

Code	Number
3R	3 suction rows
5R	5 suction rows

### 6 - Hole spacing

Code	Spacing in mm
18	18
36	36
54	54

### 7 - Sealing element

Code	Height/diameter in mm
O20	Sealing foam (height = 20)
O10O10	Sealing foam (height = 20)
N10	Sealing foam (height = 10)
SPB2-20 P	Suction cup (ø 20)
SPB2-40 P	Suction cup (ø 40)

### 8 - Protective layer

Code	Type
SU	Protective Layer
-	No protective Layer

### 9 - Filter

Code	Type
F	Filter
-	No filter

- Integrated control valves at FMP-S (optional)
- Control of vacuum on/off (24V DC, normally open) and blow off on/off (24V DC, normally closed), as well as hose accumulator preload and blower ventilation function with version FMP-S
- Integrated in the end cover
- Electrical connection: M12 plug (4-pole)

Available spare parts: sealing foam (DI-PL), suction cup (SPB2)

## Ordering Data Area Gripping Systems FMP

Type (Sealing foam)	Length L [mm]:				
	442	640	838	1234	1432
FMP-SW 3R18 O20 -	10.01.38.00433	10.01.38.00434	10.01.38.00435	10.01.38.00436	10.01.38.00437
FMP-SW 3R18 O10O10 F	10.01.38.00428	10.01.38.00429	10.01.38.00430	10.01.38.00431	10.01.38.00432
FMP-SW 5R18 O10O10 -	10.01.38.00642	10.01.38.00647	10.01.38.00648	10.01.38.00649	10.01.38.00650
FMP-SW 5R18 O10O10 F	10.01.38.00656	10.01.38.00657	10.01.38.00658	10.01.38.00659	10.01.38.00660
FMP-SW 5R18 N10SU -	10.01.38.02967	10.01.38.02968	10.01.38.02969	10.01.38.02970	10.01.38.02971
FMP-S-SW 3R18 O20 -	10.01.38.03431	10.01.38.03432	10.01.38.03433	10.01.38.03435	10.01.38.03436
FMP-S-SW 3R18 O10O10 F	10.01.38.03437	10.01.38.03438	10.01.38.03439	10.01.38.03441	10.01.38.03442
FMP-S-SW 5R18 O10O10 -	10.01.38.03455	10.01.38.03456	10.01.38.03457	10.01.38.03459	10.01.38.03460
FMP-S-SW 5R18 O10O10 F	10.01.38.03461	10.01.38.03462	10.01.38.03463	10.01.38.03465	10.01.38.03466



# Area Gripping Systems FMP

Suction area (LxW) from 442 x 130 mm to 1,432 x 130 mm



## Ordering Data Area Gripping Systems FMP

Type (Sealing foam)					Length L [mm]:				
					442	640	838	1234	1432
FMP-SVK	3R18	O20	-		10.01.38.00303	10.01.38.00411	10.01.38.00412	10.01.38.00413	10.01.38.00414
FMP-SVK	3R18	O10O10	F		10.01.38.00415	10.01.38.00416	10.01.38.00417	10.01.38.00418	10.01.38.00419
FMP-SVK	5R18	O10O10	-		10.01.38.00324	10.01.38.00643	10.01.38.00644	10.01.38.00645	10.01.38.00646
FMP-SVK	5R18	O10O10	F		10.01.38.00651	10.01.38.00652	10.01.38.00653	10.01.38.00654	10.01.38.00655
FMP-SVK	5R18	N10SU	-		10.01.38.02972	10.01.38.02973	10.01.38.02974	10.01.38.02975	10.01.38.02976
FMP-S-SVK	3R18	O20	-		10.01.38.02789	10.01.38.03420	10.01.38.03421	10.01.38.03423	10.01.38.03424
FMP-S-SVK	3R18	O10O10	F		10.01.38.03425	10.01.38.03426	10.01.38.03427	10.01.38.03429	10.01.38.03430
FMP-S-SVK	5R18	O10O10	-		10.01.38.03443	10.01.38.03444	10.01.38.03445	10.01.38.03447	10.01.38.03448
FMP-S-SVK	5R18	O10O10	F		10.01.38.03449	10.01.38.03450	10.01.38.03451	10.01.38.03453	10.01.38.03454

Type (Suction cup)					Length L [mm]:				
					442	640	838	1234	1432
FMP-SW	5R36	SPB2	20	-	10.01.38.00484	10.01.38.00485	10.01.38.00486	10.01.38.00487	10.01.38.00488
FMP-SW	5R36	SPB2	20	F	10.01.38.00489	10.01.38.00490	10.01.38.00491	10.01.38.00492	10.01.38.00493
FMP-SW	3R54	SPB2	40	-	10.01.38.00451	10.01.38.00453	10.01.38.00455	10.01.38.00456	10.01.38.00457
FMP-SW	3R54	SPB2	40	F	10.01.38.00458	10.01.38.00459	10.01.38.00460	10.01.38.00461	10.01.38.00462
FMP-S-SW	5R36	SPB2	20	-	10.01.38.03503	10.01.38.03504	10.01.38.03505	10.01.38.03507	10.01.38.03508
FMP-S-SW	5R36	SPB2	20	F	10.01.38.03509	10.01.38.03510	10.01.38.03511	10.01.38.03513	10.01.38.03514
FMP-S-SW	3R54	SPB2	40	-	10.01.38.03479	10.01.38.03480	10.01.38.03481	10.01.38.03483	10.01.38.03484
FMP-S-SW	3R54	SPB2	40	F	10.01.38.03485	10.01.38.03486	10.01.38.03487	10.01.38.03489	10.01.38.03490

Type (Suction cup)					Length L [mm]:				
					442	640	838	1234	1432
FMP-SVK	5R36	SPB2	20	-	10.01.38.00323	10.01.38.00475	10.01.38.00476	10.01.38.00477	10.01.38.00478
FMP-SVK	5R36	SPB2	20	F	10.01.38.00479	10.01.38.00480	10.01.38.00481	10.01.38.00482	10.01.38.00483
FMP-SVK	3R54	SPB2	40	-	10.01.38.00311	10.01.38.00439	10.01.38.00443	10.01.38.00444	10.01.38.00445
FMP-SVK	3R54	SPB2	40	F	10.01.38.00446	10.01.38.00447	10.01.38.00448	10.01.38.00449	10.01.38.00450
FMP-S-SVK	5R36	SPB2	20	-	10.01.38.03491	10.01.38.03492	10.01.38.03493	10.01.38.03495	10.01.38.03496
FMP-S-SVK	5R36	SPB2	20	F	10.01.38.03497	10.01.38.03498	10.01.38.03499	10.01.38.03501	10.01.38.03502
FMP-S-SVK	3R54	SPB2	40	-	10.01.38.03467	10.01.38.03468	10.01.38.03469	10.01.38.03471	10.01.38.03472
FMP-S-SVK	3R54	SPB2	40	F	10.01.38.03473	10.01.38.03474	10.01.38.03475	10.01.38.03477	10.01.38.03478



## Ordering Data Spare Parts Area Gripping Systems FMP

Type (Sealing foam)			3R18	3R18 F	5R18	5R18 F
DI-PL	442	O20	10.01.38.00113	-	-	-
DI-PL	442	O10O10	-	10.01.38.00192	10.01.38.00864	10.01.38.00622
DI-PL	442	N10SU	-	-	10.01.38.02863	-
DI-PL	640	O20	10.01.38.00405	-	-	-
DI-PL	640	O10O10	-	10.01.38.00408	10.01.38.00865	10.01.38.00627
DI-PL	640	N10SU	-	-	10.01.38.02864	-
DI-PL	838	O20	10.01.38.00140	-	-	-
DI-PL	838	O10O10	-	10.01.38.00409	10.01.38.00866	10.01.38.00628



Schmalz – The Company  
Vacuum Suction Cups  
Special Grippers  
Gripping Systems  
Clamping Systems  
Mounting Elements  
Vacuum Generators  
Valve Technology  
Switches and Monitoring  
Filters and Connections  
Services  
Contact  
Glossary  
Index of Products

# Area Gripping Systems FMP

Suction area (LxW) from 442 x 130 mm to 1,432 x 130 mm



## Ordering Data Spare Parts Area Gripping Systems FMP

Type (Sealing foam)			3R18	3R18 F	5R18	5R18 F
DI-PL	838	N10SU	-	-	10.01.38.02865	-
DI-PL	1234	O20	10.01.38.00193	-	-	-
DI-PL	1234	O10O10	-	10.01.38.00196	10.01.38.00867	10.01.38.00629
DI-PL	1234	N10SU	-	-	10.01.38.02866	-
DI-PL	1432	O20	10.01.38.00406	-	-	-
DI-PL	1432	O10O10	-	10.01.38.00410	10.01.38.00868	10.01.38.00630
DI-PL	1432	N10SU	-	-	10.01.38.02867	-

Type (Suction cup)				Spare Parts		Part no.
FMP	5R36	SPB2	-	Bellows suction cup (round)	SPB2 20 SI-40 P	10.01.06.03125
FMP	5R36	SPB2	F	Bellows suction cup (round)	SPB2 20 SI-40 P F	10.01.38.00465
FMP	3R54	SPB2	-	Bellows suction cup (round)	SPB2 40 SI-55 P	10.01.06.03126
FMP	3R54	SPB2	F	Bellows suction cup (round)	SPB2 40 SI-55 P F	10.01.38.00452



## Technical Data Area Gripping Systems FMP

Type (Sealing foam)				Number of suction cells	Evacuation rate for pu = -0,25 bar [l/min]*	Suction force [N]**	Weight [kg]
FMP-SW	442	3R18	O20	66	300	440	2.0
FMP-SW	640	3R18	O20	99	450	660	2.8
FMP-SW	838	3R18	O20	132	600	870	3.6
FMP-SW	1234	3R18	O20	198	900	1,310	5.0
FMP-SW	1432	3R18	O20	231	1,050	1,530	5.6
FMP-SW	442	3R18	O10O10	66	300	440	2.0
FMP-SW	640	3R18	O10O10	99	450	660	2.8
FMP-SW	838	3R18	O10O10	132	600	870	3.6
FMP-SW	1234	3R18	O10O10	198	900	1,310	5.0
FMP-SW	1432	3R18	O10O10	231	1,050	1,530	5.6
FMP-SW	442	5R18	O10O10	110	300	340	2.0
FMP-SW	640	5R18	O10O10	165	450	510	2.8
FMP-SW	838	5R18	O10O10	220	600	670	3.6
FMP-SW	1234	5R18	O10O10	330	900	1,010	5.0
FMP-SW	1432	5R18	O10O10	385	1,050	1,180	5.6
FMP-SW	442	5R18	N10SU	110	300	340	2.4
FMP-SW	640	5R18	N10SU	165	450	510	3.2
FMP-SW	838	5R18	N10SU	220	600	670	4.0
FMP-SW	1234	5R18	N10SU	330	900	1,010	5.4
FMP-SW	1432	5R18	N10SU	385	1,050	1,180	6.0
FMP-S-SW	442	3R18	O20	66	300	440	2.7
FMP-S-SW	640	3R18	O20	99	450	660	3.5
FMP-S-SW	838	3R18	O20	132	600	870	4.3
FMP-S-SW	1234	3R18	O20	198	900	1,310	5.7
FMP-S-SW	1432	3R18	O20	231	1,050	1,530	6.3
FMP-S-SW	442	3R18	O10O10	66	300	440	2.7



Schmalz - The Company  
Vacuum Suction Cups  
Special Grippers  
Gripping Systems  
Clamping Systems  
Mounting Elements  
Vacuum Generators  
Valve Technology  
Switches and Monitoring  
Filters and Connections  
Services  
Contact  
Glossary  
Index of Products

# Area Gripping Systems FMP

Suction area (LxW) from 442 x 130 mm to 1,432 x 130 mm



## Technical Data Area Gripping Systems FMP

Type (Sealing foam)				Number of suction cells	Evacuation rate for pu = -0,25 bar [l/min]*	Suction force [N]**	Weight [kg]
FMP-S-SW	640	3R18	O10O10	99	450	660	3.5
FMP-S-SW	838	3R18	O10O10	132	600	870	4.3
FMP-S-SW	1234	3R18	O10O10	198	900	1,310	5.7
FMP-S-SW	1432	3R18	O10O10	231	1,050	1,530	6.3
FMP-S-SW	442	5R18	O10O10	110	300	340	2.7
FMP-S-SW	640	5R18	O10O10	165	450	510	3.5
FMP-S-SW	838	5R18	O10O10	220	600	670	4.3
FMP-S-SW	1234	5R18	O10O10	330	900	1,010	5.7
FMP-S-SW	1432	5R18	O10O10	385	1,050	1,180	6.3

\*The external vacuum generator used must supply at least the specified suction flow (at the vacuum connection piece of the FMP) at -0.25 bar but max. 135 % of the specified suction flow

\*\*At a vacuum of -0.25 bar and with the gripper fully covered by a workpiece typical for the application. The suction forces are references for general designs. Suction tests with the original workpiece are always recommended for designing specific systems.

Type (Sealing foam)				Number of suction cells	Evacuation rate for pu = -0,25 bar [l/min]*	Suction force [N]**	Weight [kg]
FMP-SVK	442	3R18	O20	66	300	550	2.1
FMP-SVK	640	3R18	O20	99	450	820	2.9
FMP-SVK	838	3R18	O20	132	600	1,090	3.7
FMP-SVK	1234	3R18	O20	198	900	1,650	5.1
FMP-SVK	1432	3R18	O20	231	1,050	1,910	5.7
FMP-SVK	442	3R18	O10O10	66	300	550	2.1
FMP-SVK	640	3R18	O10O10	99	450	820	2.9
FMP-SVK	838	3R18	O10O10	132	600	1,090	3.7
FMP-SVK	1234	3R18	O10O10	198	900	1,650	5.1
FMP-SVK	1432	3R18	O10O10	231	1,050	1,910	5.7
FMP-SVK	442	5R18	O10O10	110	300	430	2.1
FMP-SVK	640	5R18	O10O10	165	450	630	2.9
FMP-SVK	838	5R18	O10O10	220	600	840	3.7
FMP-SVK	1234	5R18	O10O10	330	900	1,270	5.1
FMP-SVK	1432	5R18	O10O10	385	1,050	1,470	5.7
FMP-SVK	442	5R18	N10SU	110	300	430	2.5
FMP-SVK	640	5R18	N10SU	165	450	630	3.3
FMP-SVK	838	5R18	N10SU	220	600	840	4.1
FMP-SVK	1234	5R18	N10SU	330	900	1,270	5.5
FMP-SVK	1432	5R18	N10SU	385	1,050	1,470	6.1
FMP-S-SVK	442	3R18	O20	66	300	550	2.8
FMP-S-SVK	640	3R18	O20	99	450	820	3.6
FMP-S-SVK	838	3R18	O20	132	600	1,090	4.4
FMP-S-SVK	1234	3R18	O20	198	900	1,650	5.8
FMP-S-SVK	1432	3R18	O20	231	1,050	1,910	6.4
FMP-S-SVK	442	3R18	O10O10	66	300	550	2.8
FMP-S-SVK	640	3R18	O10O10	99	450	820	3.6
FMP-S-SVK	838	3R18	O10O10	132	600	1,090	4.4
FMP-S-SVK	1234	3R18	O10O10	198	900	1,650	5.8
FMP-S-SVK	1432	3R18	O10O10	231	1,050	1,910	6.4
FMP-S-SVK	442	5R18	O10O10	110	300	430	2.8
FMP-S-SVK	640	5R18	O10O10	165	450	630	3.6



- Schmalz – The Company
- Vacuum Suction Cups
- Special Grippers
- Gripping Systems
- Clamping Systems
- Mounting Elements
- Vacuum Generators
- Valve Technology
- Switches and Monitoring
- Filters and Connections
- Services
- Contact
- Glossary
- Index of Products

# Area Gripping Systems FMP

Suction area (LxW) from 442 x 130 mm to 1,432 x 130 mm



## Technical Data Area Gripping Systems FMP

Type (Sealing foam)				Number of suction cells	Evacuation rate for pu = -0,25 bar [l/min]*	Suction force [N]**	Weight [kg]
FMP-S-SVK	838	5R18	O10O10	220	600	840	4.4
FMP-S-SVK	1234	5R18	O10O10	330	900	1,270	5.8
FMP-S-SVK	1432	5R18	O10O10	385	1,050	1,470	6.4

\*The external vacuum generator used must supply at least the specified suction flow (at the vacuum connection piece of the FMP) at -0.25 bar but max. 135 % of the specified suction flow

\*\*At a vacuum of -0.25 bar and with the gripper fully covered by a workpiece typical for the application. The suction forces are references for general designs. Suction tests with the original workpiece are always recommended for designing specific systems.

Type (Suction cup)				Number of suction cells	Evacuation rate for pu = -0,25 bar [l/min]*	Suction force [N]**	Weight [kg]
FMP-SW	442	5R36	SPB2	55	300	140	2.5
FMP-SW	640	5R36	SPB2	82	450	210	3.5
FMP-SW	838	5R36	SPB2	110	600	280	4.3
FMP-SW	1234	5R36	SPB2	165	900	420	6.0
FMP-SW	1432	5R36	SPB2	193	1,050	490	6.8
FMP-SW	442	3R54	SPB2	23	300	200	2.6
FMP-SW	640	3R54	SPB2	33	450	290	3.6
FMP-SW	838	3R54	SPB2	44	600	390	4.5
FMP-SW	1234	3R54	SPB2	66	900	580	6.2
FMP-SW	1432	3R54	SPB2	77	1,050	680	7.0
FMP-S-SW	442	5R36	SPB2	55	300	140	3.2
FMP-S-SW	640	5R36	SPB2	82	450	210	4.2
FMP-S-SW	838	5R36	SPB2	110	600	280	5.0
FMP-S-SW	1234	5R36	SPB2	165	900	420	6.7
FMP-S-SW	1432	5R36	SPB2	193	1,050	490	7.5
FMP-S-SW	442	3R54	SPB2	23	300	200	3.3
FMP-S-SW	640	3R54	SPB2	33	450	290	4.3
FMP-S-SW	838	3R54	SPB2	44	600	390	5.2
FMP-S-SW	1234	3R54	SPB2	66	900	580	6.9
FMP-S-SW	1432	3R54	SPB2	77	1,050	680	7.7

\*The external vacuum generator used must supply at least the specified suction flow (at the vacuum connection piece of the FMP) at -0.25 bar but max. 135 % of the specified suction flow

\*\*At a vacuum of -0.25 bar and with the gripper fully covered by a workpiece typical for the application. The suction forces are references for general designs. Suction tests with the original workpiece are always recommended for designing specific systems.

Type (Suction cup)				Number of suction cells	Evacuation rate for pu = -0,25 bar [l/min]*	Suction force [N]**	Weight [kg]
FMP-SVK	442	5R36	SPB2	55	300	180	2.6
FMP-SVK	640	5R36	SPB2	82	450	270	3.6
FMP-SVK	838	5R36	SPB2	110	600	360	4.4
FMP-SVK	1234	5R36	SPB2	165	900	540	6.1
FMP-SVK	1432	5R36	SPB2	193	1,050	630	6.9
FMP-SVK	442	3R54	SPB2	23	300	250	2.7
FMP-SVK	640	3R54	SPB2	33	450	360	3.7
FMP-SVK	838	3R54	SPB2	44	600	480	4.6
FMP-SVK	1234	3R54	SPB2	66	900	720	6.3
FMP-SVK	1432	3R54	SPB2	77	1,050	840	7.1
FMP-S-SVK	442	5R36	SPB2	55	300	180	3.3
FMP-S-SVK	640	5R36	SPB2	82	450	270	4.3
FMP-S-SVK	838	5R36	SPB2	110	600	360	5.1
FMP-S-SVK	1234	5R36	SPB2	165	900	540	6.8



# Area Gripping Systems FMP

Suction area (LxW) from 442 x 130 mm to 1,432 x 130 mm



## Technical Data Area Gripping Systems FMP

Type (Suction cup)				Number of suction cells	Evacuation rate for pu = -0,25 bar [l/min]*	Suction force [N]**	Weight [kg]
FMP-S-SVK	1432	5R36	SPB2	193	1,050	630	7.6
FMP-S-SW	442	3R54	SPB2	23	300	200	3.3
FMP-S-SW	640	3R54	SPB2	33	450	290	4.3
FMP-S-SW	838	3R54	SPB2	44	600	390	5.2
FMP-S-SW	1234	3R54	SPB2	66	900	580	6.9
FMP-S-SW	1432	3R54	SPB2	77	1,050	680	7.7

\*The external vacuum generator used must supply at least the specified suction flow (at the vacuum connection piece of the FMP) at -0.25 bar but max. 135 % of the specified suction flow

\*\*At a vacuum of -0.25 bar and with the gripper fully covered by a workpiece typical for the application. The suction forces are references for general designs. Suction tests with the original workpiece are always recommended for designing specific systems.



## Design Data Area Gripping Systems FMP

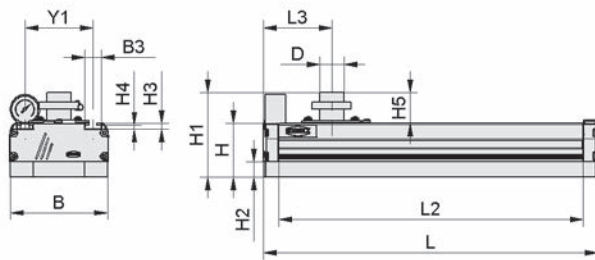

FMP O20, O10010, N10SU

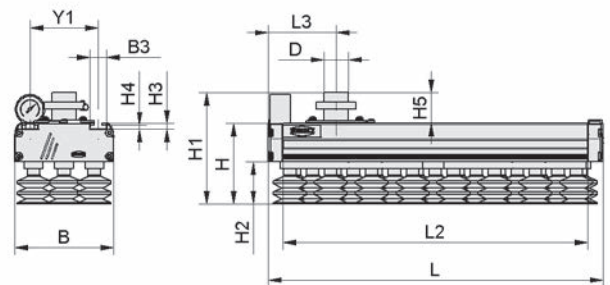

FMP SPB2

Type (Sealing foam)	B [mm]	B3 [mm]	D [mm]*	H [mm]	H1 [mm]	H2 [mm]**	H3 [mm]	H4 [mm]	H5 [mm]	L [mm]	L2 [mm]	L3 [mm]	Y1 [mm]
FMP	3R18	130	22	32	70	111	20	7.7	5.5	41	442	402	90
FMP	3R18	130	22	32	70	111	20	7.7	5.5	41	640	600	90
FMP	3R18	130	22	60	70	116	20	7.7	5.5	46	838	798	90
FMP	3R18	130	22	60	70	116	20	7.7	5.5	46	1,234	1,194	90
FMP	3R18	130	22	60	70	116	20	7.7	5.5	46	1,432	1,392	90
FMP	5R18	130	22	32	60	90	10	7.7	5.5	41	442	402	90
FMP	5R18	130	22	32	60	90	10	7.7	5.5	41	640	600	90
FMP	5R18	130	22	60	60	90	10	7.7	5.5	41	838	798	90
FMP	5R18	130	22	60	60	90	10	7.7	5.5	41	1,234	1,194	90
FMP	5R18	130	22	60	60	90	10	7.7	5.5	41	1,432	1,392	90
FMP-S	3R18	130	22	32	70	111	20	7.7	5.5	41	442	402	77
FMP-S	3R18	130	22	32	70	111	20	7.7	5.5	41	640	600	77
FMP-S	3R18	130	22	60	70	116	20	7.7	5.5	46	838	798	77
FMP-S	3R18	130	22	60	70	116	20	7.7	5.5	46	1,234	1,194	77



# Area Gripping Systems FMP

Suction area (LxW) from 442 x 130 mm to 1,432 x 130 mm



## Design Data Area Gripping Systems FMP

Type (Sealing foam)		B	B3	D	H	H1	H2	H3	H4	H5	L	L2	L3	Y1
		[mm]	[mm]	[mm]*	[mm]	[mm]	[mm]**	[mm]	[mm]	[mm]	[mm]	[mm]	[mm]	[mm]
FMP-S	3R18	130	22	60	70	116	20	7.7	5.5	46	1,432	1,392	77	90
FMP-S	5R18	130	22	32	70	111	20	7.7	5.5	41	442	402	77	90
FMP-S	5R18	130	22	32	70	111	20	7.7	5.5	41	640	600	77	90
FMP-S	5R18	130	22	60	70	116	20	7.7	5.5	46	838	798	77	90
FMP-S	5R18	130	22	60	70	116	20	7.7	5.5	46	1,234	1,194	77	90
FMP-S	5R18	130	22	60	70	116	20	7.7	5.5	46	1,432	1,392	77	90

\*Vacuum hose with internal diameter equal to dimension D required

\*\*Acceptable dimensional tolerances for rubber parts concerning to DIN ISO 3302-1 M3

Type (Suction cup)			B	B3	D	H	H1	H2	H3	H4	H5	L	L2	L3	Y1
			[mm]	[mm]	[mm]	[mm]	[mm]	[mm]	[mm]	[mm]	[mm]	[mm]	[mm]	[mm]	[mm]
FMP	3R54	SPB2	130	22	32	105	146	55	8	6	41	442	402	90	90
FMP	3R54	SPB2	130	22	32	105	146	55	8	6	41	640	600	90	90
FMP	3R54	SPB2	130	22	60	105	151	55	8	6	46	838	798	90	90
FMP	3R54	SPB2	130	22	60	105	151	55	8	6	46	1,234	1,194	90	90
FMP	3R54	SPB2	130	22	60	105	151	55	8	6	46	1,432	1,392	90	90
FMP-S	3R54	SPB2	130	22	32	105	146	55	8	6	41	442	402	77	90
FMP-S	3R54	SPB2	130	22	32	105	146	55	8	6	41	640	600	77	90
FMP-S	3R54	SPB2	130	22	60	105	151	55	8	6	46	838	798	77	90
FMP-S	3R54	SPB2	130	22	60	105	151	55	8	6	46	1,234	1,194	77	90
FMP-S	3R54	SPB2	130	22	60	105	151	55	8	6	46	1,432	1,392	77	90
FMP	5R36	SPB2	130	22	32	83	124	33	8	6	41	442	402	90	90
FMP	5R36	SPB2	130	22	32	83	124	33	8	6	41	640	600	90	90
FMP	5R36	SPB2	130	22	60	83	129	33	8	6	46	838	798	90	90
FMP	5R36	SPB2	130	22	60	83	129	33	8	6	46	1,234	1,194	90	90
FMP	5R36	SPB2	130	22	60	83	129	33	8	6	46	1,432	1,392	90	90
FMP-S	5R36	SPB2	130	22	32	83	124	33	8	6	41	442	402	77	90
FMP-S	5R36	SPB2	130	22	32	83	124	33	8	6	41	640	600	77	90
FMP-S	5R36	SPB2	130	22	60	83	129	33	8	6	46	838	798	77	90
FMP-S	5R36	SPB2	130	22	60	83	129	33	8	6	46	1,234	1,194	77	90
FMP-S	5R36	SPB2	130	22	60	83	129	33	8	6	46	1,432	1,392	77	90



- Schmalz – The Company
- Vacuum Suction Cups
- Special Grippers
- Gripping Systems
- Clamping Systems
- Mounting Elements
- Vacuum Generators
- Valve Technology
- Switches and Monitoring
- Filters and Connections
- Services
- Contact
- Glossary
- Index of Products

# Area Gripping Systems FMHD

Suction area (LxW) from 304 x 168 mm to 1,760 x 168 mm



Area Gripping Systems FMHD

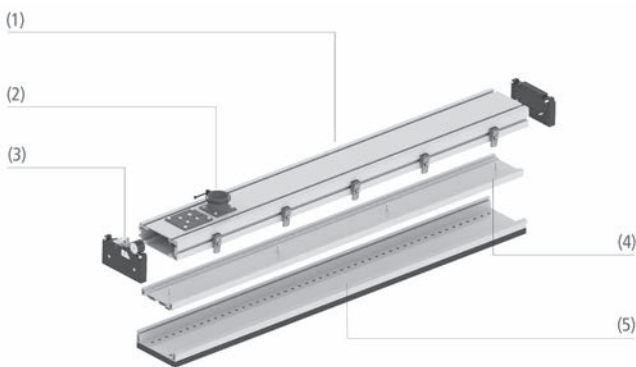

System Design Area Gripping Systems FMHD



Area Gripping system FMHD handling rough sawn wooden boards

## Suitability for Industry Specific Applications

### Applications

- Robust gripping system with connection for external vacuum generator for the efficient handling of sawn timber, planed and glued products, plate products, construction timber, pallets and box elements
- Handling of naturally grown material with knotholes, cracks and heavily twisted, rough surfaces
- Ideal for the rough application conditions in sawmills or in woodworking and furniture construction
- Can be used for layer-wise unstacking and relocation of workpieces

### Design

- Aluminum basic profile (1) with integrated vacuum storage for high rigidity with low dead weight
- Hose connection and separating cylinder (2); connection of external vacuum generators
- End cover (3) with control valves for separating cylinder and blow off function
- Valve profile (4) with integrated missile valves
- Quick change profile with sealing foam and quick-change adhesive film (5); easy to maintain

### Our Highlights...

- More holding power
- Unique flexibility
- Low dead weight

### Your Benefits...

- Outstanding holding force for heavily porous and twisted workpieces thanks to integrated vacuum reservoir
- Handling of workpieces from 50 mm width, regardless of geometry, surface and position
- Maximum process acceleration



- Schmalz – The Company
- Vacuum Suction Cups
- Special Grippers
- Gripping Systems
- Clamping Systems
- Mounting Elements
- Vacuum Generators
- Valve Technology
- Switches and Monitoring
- Filters and Connections
- Services
- Contact
- Glossary
- Index of Products

# Area Gripping Systems FX-SW

Suction area (LxW) 120 x 60 mm



## Suitability for Industry Specific Applications

### Applications

- For use in packaging processes for handling a wide range of products, e.g. filling boxes
- Ideal for integration in packaging machines (e.g. case packers) due to its compact dimensions and low weight
- For use on vacuum suction spiders for handling bending workpieces such as metal sheets and veneer
- FX type with integrated vacuum generation (ejector)



Area Gripping Systems FX-SW

### Design

- Plastic main body (1) with integrated pneumatic vacuum generator and connections (2) for ejector hosing
- Plug-in suction plate (3) with integrated flow restrictors
- Sealing element (4): sealing foam or suction cups
- Optional vacuum sensor and external blow off function

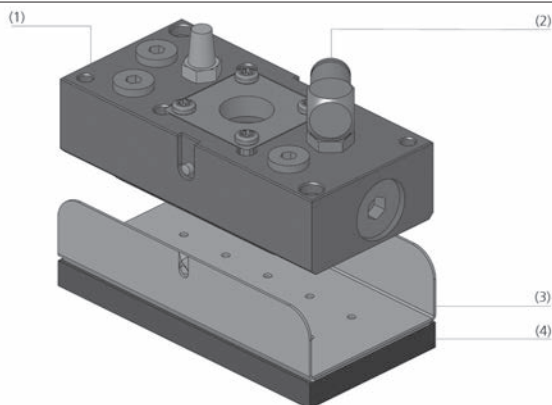

System Design Area Gripping Systems FX-SW



Area Gripping system FX-SW when handling wooden boards

### Our Highlights...

- Integrated vacuum generator
- Choice of suction cup or sealing foam as the sealing element
- Integrated flow restrictors
- Main body made of plastic

### Your Benefits...

- Rapid vacuum power build-up for short cycles; minimum interference contours
- Gripper optimally adapted to the application
- Minimal leakage losses when cells are not in use
- High stiffness at a low weight

Schmalz – The Company

Vacuum Suction Cups

Special Grippers

Gripping Systems

Clamping Systems

Mounting Elements

Vacuum Generators

Valve Technology

Switches and Monitoring

Filters and Connections

Services

Contact

Glossary

Index of Products





# Area Gripping Systems FX-SW

Suction area (LxW) 120 x 60 mm

## Designation Code Area Gripping Systems FX-SW

<b>FX</b>	-	<b>SW</b>	-	<b>120x60</b>	-	<b>20</b>	-	<b>N10</b>	-	<b>SEA</b>
1		2		3		4		5		6

### 1 – Abbreviated designation

Code	Version
FX	Integrated vacuum generator

### 2 – Valve technology

Code	Type
SW	Flow restrictor

### 3 – LxW

Code	LxW in mm
120x60	120x60

### 4 – Hole spacing

Code	Spacing in mm
20	20
20x20	20x20

### 5 – Sealing element

Code	Number, height/diameter in mm
N10 10	Sealing foam (height = 10)
14xFSG-12	14 suction cups (ø 12)

### 6 – Blow off function

Code	Version
SEA	Integrated blow off piston
-	No blow off piston

Gripping system FX-SW is delivered as a ready-to-connect product.

Available spare parts: sealing plate, suction cup FG

## Ordering Data Area Gripping Systems FX-SW

Type	Part no.
FX-SW 120x60 20x20 N10 10 SEA	10.01.11.01800
FX-SW 120x60 20x20 N10 10	10.01.11.01802

Type	Part no.
FX-SW 120x60 20 14xFSG-12 SEA	10.01.11.02008
FX-SW 120x60 20 14xFSG-12	10.01.11.02009

## Ordering Data Spare Parts Area Gripping Systems FX-SW

Type	Spare Parts	Part no.
FX-SW 120x60 20x20 N10 10 SEA	Sealing plate (FX/FM)	DI-PL 120x60 N10 10.01.10.00874
FX-SW 120x60 20x20 N10 10	Sealing plate (FX/FM)	DI-PL 120x60 N10 10.01.10.00874

Type	Spare Parts	Part no.
FX-SW 120x60 20 14xFSG-12 SEA	Bellows suction cup (round)	FG 12 NK-45 N016 10.01.06.00558
FX-SW 120x60 20 14xFSG-12	Bellows suction cup (round)	FG 12 NK-45 N016 10.01.06.00558

# Area Gripping Systems FX-SW

Suction area (LxW) 120 x 60 mm

Schmalz - The Company  
Vacuum Suction Cups  
Special Grippers  
Gripping Systems  
Clamping Systems  
Mounting Elements  
Vacuum Generators  
Valve Technology  
Switches and Monitoring  
Filters and Connections  
Services  
Contact  
Glossary  
Index of Products



## Technical Data Area Gripping Systems FX-SW

Type	Number of suction cells	Air consumption [l/min]*	Suction rate (max) [l/min]	Holding force at 60 % vacuum [N]**	Weight [kg]
FX-SW 120x60 20x20 N10 10 SEA	10	117	69	98	0.8
FX-SW 120x60 20x20 N10 10	10	117	69	98	0.7
FX-SW 120x60 20 14xFSG-12 SEA	14	117	69	13	1.1
FX-SW 120x60 20 14xFSG-12	14	117	69	13	1.0

\*For compressed air with 5 bar input pressure  
\*\*With the gripper fully covered by a rigid workpiece



## Design Data Area Gripping Systems FX-SW

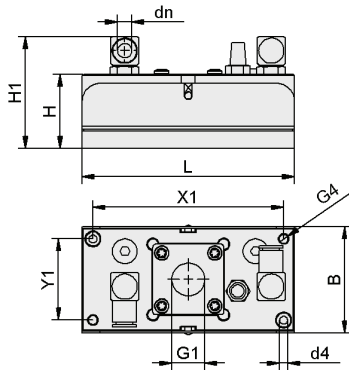

FX-SW N10 10 SEA

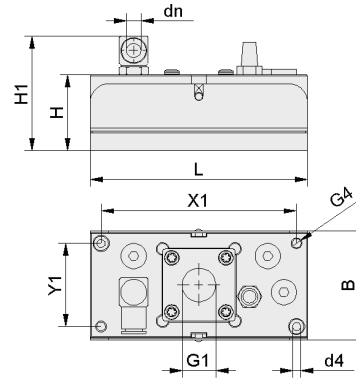

FX-SW N10 10

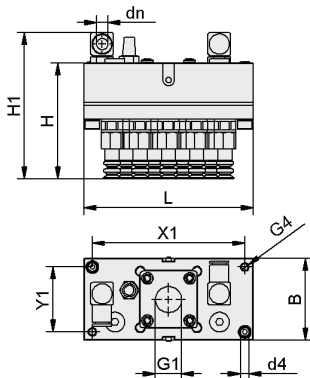

FX-SW 20 FSG12 SEA

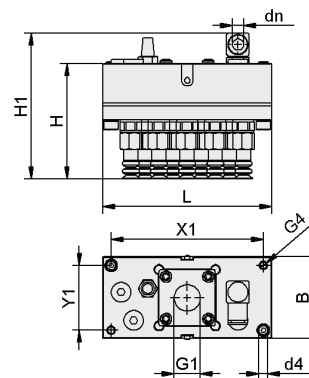

FX-SW 20 FSG12

Type	B [mm]	dn [mm]*	d4 [mm]	G1	G4	H [mm]	H1 [mm]	L [mm]	X1 [mm]	Y1 [mm]
FX-SW 120x60 20x20 N10 10 SEA	60	8	4.5	G1/2"-F	M6-F	43	64	120	108	46
FX-SW 120x60 20x20 N10 10	60	8	4.5	G1/2"-F	M6-F	43	64	120	108	46
FX-SW 120x60 20 14xFSG-12 SEA	60	8	4.5	G1/2"-F	M6-F	82	104	120	108	46
FX-SW 120x60 20 14xFSG-12	60	8	4.5	G1/2"-F	M6-F	82	104	120	108	46

\*Requires an 8/6 mm compressed air hose

# Area Gripping Systems FM-SW

Suction area (LxW) from 76 x 22 mm to 120 x 60 mm

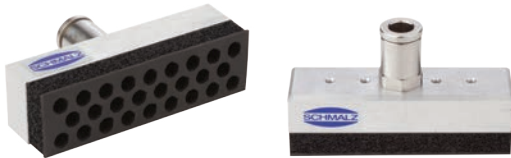

Area Gripping Systems FM-SW

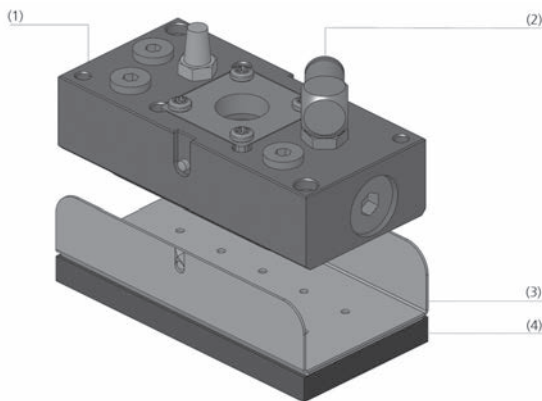

System Design Area Gripping Systems FM-SW

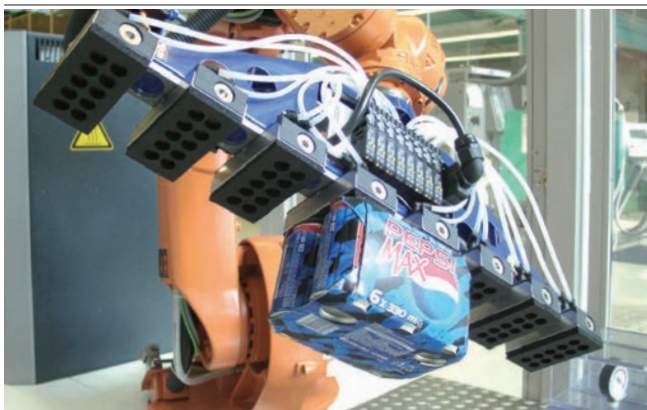

Area Gripping system FM-SW handling beverage packaging

## Suitability for Industry Specific Applications

### Applications

- For use in packaging processes for handling a wide range of products, e.g. filling boxes
- Ideal for integration in packaging machines (e.g. case packers) due to its compact dimensions and low weight
- For use on vacuum suction spiders for handling bending workpieces such as metal sheets and veneer
- FM type with connection for external vacuum generation

### Design

- Plastic main body (1) with connections (2) for the external vacuum generator hoses
- Plug-in suction plate (3) with integrated flow restrictors
- Sealing element (4): sealing foam or suction cups
- Optional vacuum sensor and external blow off function

### Our Highlights...

- External vacuum generator
- Choice of suction cup or sealing foam as the sealing element
- Integrated flow restrictors
- Base section made of plastic

### Your Benefits...

- High flow rates and vacuum power up to -0.8 bar; low operating costs
- Gripper optimally adapted to the application
- Minimal leakage losses when cells are not in use
- High stiffness at a low weight

# Area Gripping Systems FM-SW

Suction area (LxW) from 76 x 22 mm to 120 x 60 mm

## Designation Code Area Gripping Systems FM-SW

<b>FM</b>	-	<b>SW</b>	-	<b>120x60</b>	-	<b>20</b>	-	<b>14xFSG12</b>	-	<b>SEA</b>
<b>1</b>		<b>2</b>		<b>3</b>		<b>4</b>		<b>5</b>		<b>6</b>

### 1 – Abbreviated designation

Code	Version
FM	External vacuum generator

### 2 – Valve technology

Code	Type
SW	Flow restrictor

### 3 – LxW

Code	LxW in mm
76x22	76x22
120x60	120x60

### 4 – Hole spacing

Code	Spacing in mm
20	20
20x20	20x20
8x12	8x12

### 5 – Sealing element

Code	Number, height/diameter in mm
N10	Sealing foam (height = 10)
14xFSG-12	14 suction cups (ø 12)

### 6 – Blow off function

Code	Version
SEA	Integrated blow off piston
-	No blow off piston

Gripping System FM-SW is delivered as a ready-to-connect product.

Available spare parts: sealing plate, suction cup FG

## Ordering Data Area Gripping Systems FM-SW

Type	Part no.
FM-SW 76x22 8x12 N10	10.01.11.00851
FM-SW 120x60 20x20 N10	10.01.11.01823

Type	Part no.
FM-SG 120x60 20 14xFSG12	10.01.11.02010

## Ordering Data Spare Parts Area Gripping Systems FM-SW

Type	Spare Parts	Part no.	
FM-SW 76x22 8x12 N10	Sealing plate	DI-PL 76x22 N10 FLGR	10.01.11.01388
FM-SW 120x60 20x20 N10	Sealing plate (FX/FM)	DI-PL 120x60 N10	10.01.10.00874

Type	Spare Parts	Part no.	
FM-SG 120x60 20 14xFSG12	Bellows suction cup (round)	FG 12 NK-45 N016	10.01.06.00558

## Technical Data Area Gripping Systems FM-SW

Type	Number of suction cells	Holding force at 60 % vacuum [N]*	Weight [kg]
FM-SW 76x22 8x12 N10	26	40	0.1
FM-SW 120x60 20x20 N10	10	98	0.5
FM-SG 120x60 20 14xFSG12	14	13	0.8

\*With the gripper fully covered by a rigid workpiece

# Area Gripping Systems FM-SW

Suction area (LxW) from 76 x 22 mm to 120 x 60 mm



## Design Data Area Gripping Systems FM-SW

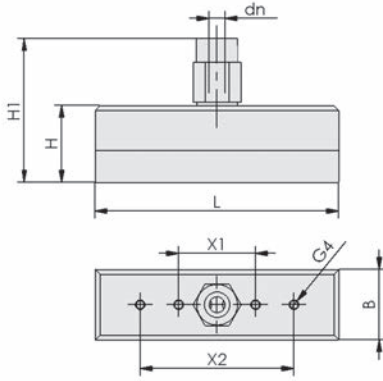

FM-SW 76x22 N10

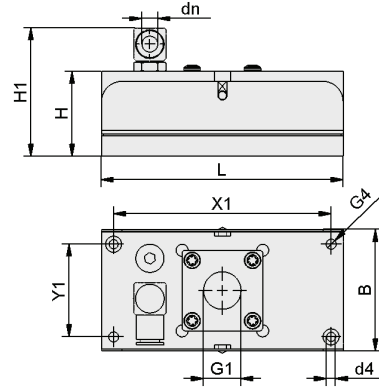

FM-SW 120x60 N10

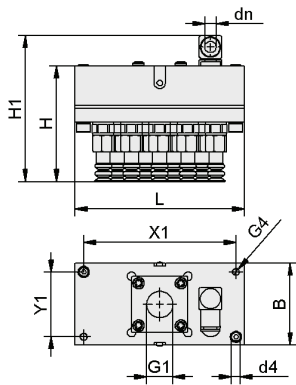

FM-SW 120x60 20 FSG12

Type	B [mm]	d4 [mm]	dn [mm]*	G1	G4	H [mm]	H1 [mm]	L [mm]	X1 [mm]	X2 [mm]	Y1 [mm]
FM-SW 76x22 8x12 N10	22	-	8	-	M3x0.5-F	24	45	76	24	48	-
FM-SW 120x60 20x20 N10	60	4.5	8	G1/2"-F	M6-F	42	64	120	108	-	46
FM-SG 120x60 20 14xFSG12	60	4.5	-	G1/2"-F	M6-F	82	104	120	108	-	46

\*Requires an 8/6 mm compressed air hose

Schmalz –  
The Company

Vacuum  
Suction Cups

Special  
Grippers

Gripping  
Systems

Clamping  
Systems

Mounting  
Elements

Vacuum  
Generators

Valve  
Technology

Switches and  
Monitoring

Filters and  
Connections

Services

Contact

Glossary

Index of  
Products

# Selection Aid Area Gripping Systems SBX-C

Very Robust Grippers for the Timber and Woodworking Industry



## Application

- Robust gripper for powerful handling of lumber, planed or glued timber, sheet materials, construction timber, pallets and crate elements
- Handling of naturally grown materials with knots or cracks or with warped, rough surfaces
- Ideal for the rough application conditions in sawmills or in woodworking and furniture construction
- As double gripper configuration also suitable for unstacking and transporting workpieces in layers
- Ideal for operation with industrial robots and gantries due to its low weight and compact dimensions

Vacuum gripping systems SBX-C

## Design

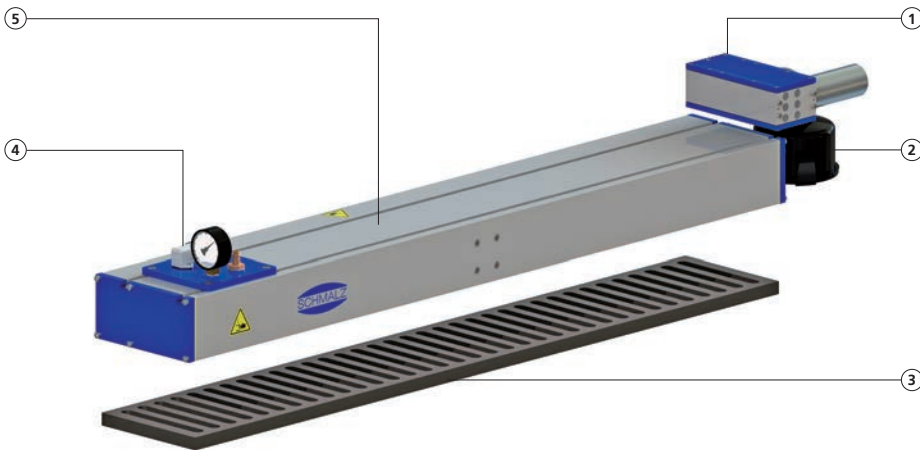

- ① **Vacuum generation**
  - Multi-stage ejector
  - Connection for external vacuum generators as an option
- ② **Dust filter**
- ③ **Sealing foam**
  - Rebounds quickly and is resistant to wear due to the sandwich design
  - Quick-change adhesive film
- ④ **Compact valve unit**
  - With control valves, vacuum gauge, electrical and pneumatic connections
  - Easily removed and therefore maintenance-friendly
- ⑤ **Aluminum base section**
  - Integrated vacuum reservoir
  - High stiffness and low weight

System Design Area Gripping System SBX-C

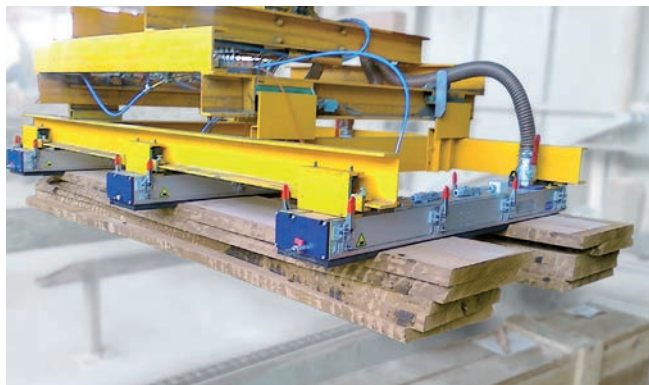

Area Gripping System SBX-C on an portal when handling wooden boards

## Your Benefits

- Extra high holding force for extremely porous and warped workpieces
- Automatic switching off of uncovered suction cells in order to sustain maximum system pressure
- Fast vacuum generation to minimize cycle times
- Maintenance-friendly due to compact valve unit and quick-change sealing foam
- Easy system integration due to pluggable connections
- Adaptation of the area gripper to the particular application case

Schmalz – The Company  
Vacuum Suction Cups  
Special Grippers  
Gripping Systems  
Clamping Systems  
Mounting Elements  
Vacuum Generators  
Valve Technology  
Switches and Monitoring  
Filters and Connections  
Services  
Contact  
Glossary  
Index of Products

## Product Specifications

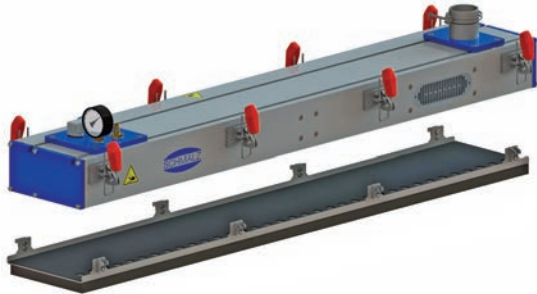

### Quick-Change Plate

- Quick and easy changing of the sealing plate using quick-release clamp
- Allows soaked or frozen sealing plates to be used again after drying

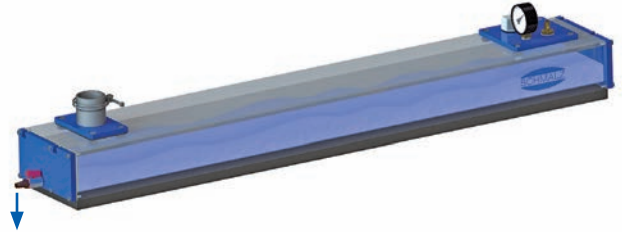

### Water Removal System

- Reliably removes any water that is sucked into the gripper
- Increased process reliability for wet workpieces
- Basic version: manually operated valve
- Advanced version: electrically operated valve

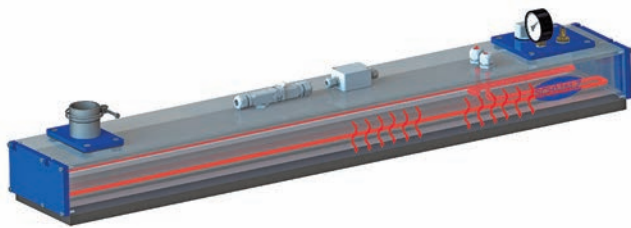

### Heating System

- The area gripper is slightly heated by a heating system
- Prevents moisture from freezing on the gripper when temperatures are low in outdoor applications

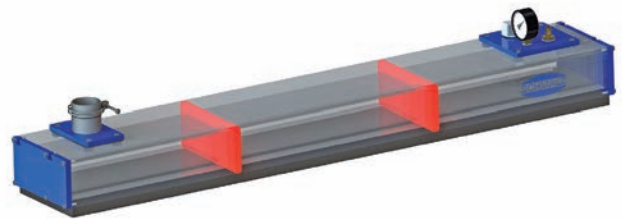

### Gripper Segmentation

- Sectioning of the gripper into multiple suction zones that can be adjusted as needed and asynchronously controlled
- Prevents intermediate layers from being picked up inadvertently
- Min. zone size of 315 mm (for standard grid)

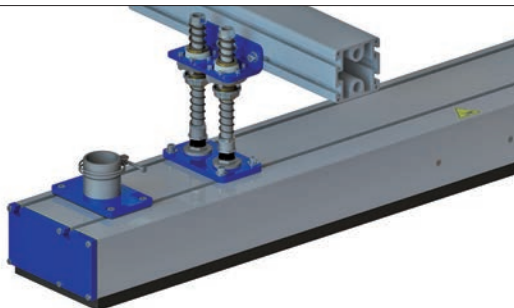

### Spring-Loaded Level Compensation

- Quick mounting on beams and gantries
- Jointed / spring-loaded design for optimal height compensation and gentle setting down on the workpiece

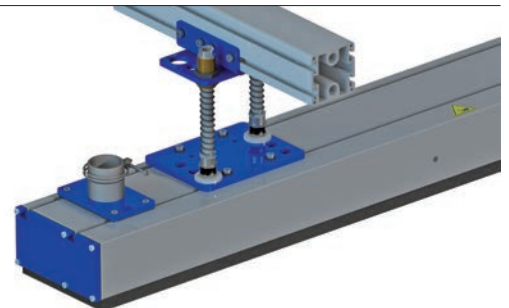

### Flexible Level Compensation

- Spring plunger with spherical bearing
- Maximum flexibility for extremely uneven layers of workpieces
- Responsive in all directions
- Self-centering and therefore no jamming

Schmalz –  
The Company

Vacuum  
Suction Cups

Special  
Grippers

Gripping  
Systems

Clamping  
Systems

Mounting  
Elements

Vacuum  
Generators

Valve  
Technology

Switches and  
Monitoring

Filters and  
Connections

Services

Contact

Glossary

Index of  
Products



# Area Gripping Systems SBX-C with Ejector

Suction area (LxW) from 1,040 x 200 mm to 1,250 x 200 mm



## Suitability for Industry Specific Applications

### Applications

- Robust gripper with integrated, pneumatic vacuum generation, for powerful handling of lumber, planed or glued timber, sheet materials, pallets, crate elements
- Handling of naturally grown materials with knots or cracks or with warped, rough surfaces
- Ideal for the rough application conditions in saw mills or in woodworking and furniture construction
- As double gripper configuration also suitable for unstacking and transporting workpieces in layers
- Ideal for operation with industrial robots and gantries due to its low weight and compact dimensions

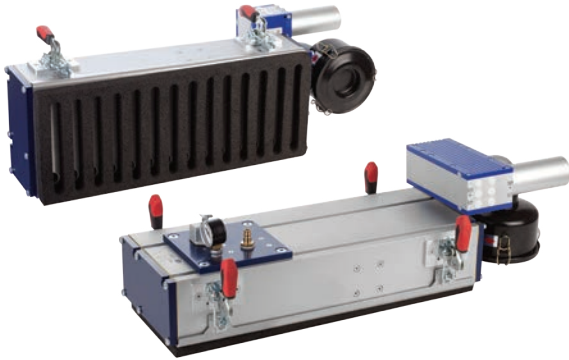

Area Gripping Systems SBX-C with Ejector

### Design

- Aluminum basic profile (1) with integrated vacuum reservoir
- Compact valve units (2) with control valves, vacuum gauges and electrical and pneumatic connections; valve unit is removable
- Sealing foam (3) rebounds quickly and resistant to wear thanks to its sandwich design, with quick-change adhesive film
- Dust filter (4)
- Multi-stage ejector (5) as a vacuum generator

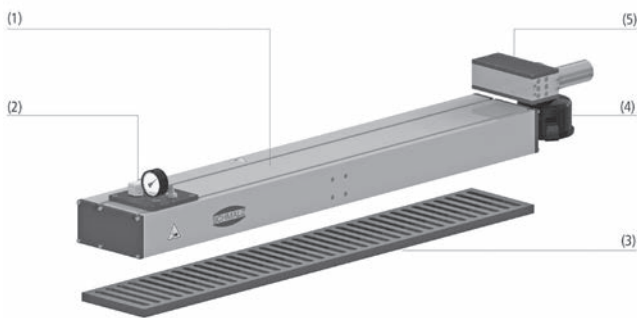

System Design Area Gripping Systems SBX-C with Ejector

### Our Highlights...

- Pneumatic vacuum generator (multi-stage ejector)
- Unused suction cells are switched off automatically
- Wear-resistant sealing foam with adhesive film
- Compact valve unit

### Your Benefits...

- Rapid vacuum build-up for short cycles; minimum interference contours
- System pressure is maintained even when partially covered
- Long service life and low maintenance costs due to easy removal of sealing foam
- Maintenance friendly due to easy removal



Area Gripping Systems SBX-C on an industrial gantry for handling unplanned wooden boards



Schmalz – The Company  
Vacuum Suction Cups  
Special Grippers  
Gripping Systems  
Clamping Systems  
Mounting Elements  
Vacuum Generators  
Valve Technology  
Switches and Monitoring  
Filters and Connections  
Services  
Contact  
Glossary  
Index of Products



# Area Gripping Systems SBX-C with Ejector

Suction area (LxW) from 1,040 x 200 mm to 1,250 x 200 mm

## Designation Code Area Gripping Systems SBX-C with Ejector

<b>SBX</b>	-	<b>C</b>	-	<b>1040x200</b>	-	<b>35</b>	-	<b>O10O10S05</b>	-	<b>SEM-150</b>
1		2		3		4		5		6

### 1 – Abbreviated designation

Code	Version
SBX	SBX

### 2 – Valve unit

Code	Version
C	Integrated compact valve unit

### 3 – LxW

Code	LxW in mm
1040x200	1040x200
1250x200	1250x200

### 4 – Hole spacing

Code	Spacing in mm
35	35

### 5 – Sealing element

Code	Height in mm
O10O10S05	25

### 6 – Vacuum generation

Code	Version
SEM-150	With multi-stage ejector SEM-150

Gripping system SBX-C is delivered as a ready-to-connect product.

Available spare parts: sealing plate

## Ordering Data Area Gripping Systems SBX-C with Ejector

Type	Part no.
SBX-C 1040x200 35 O10O10S05 SEM-150	10.01.20.01000
SBX-C 1250x200 35 O10O10S05 SEM-150	10.01.20.01001

## Ordering Data Spare Parts Area Gripping Systems SBX-C with Ejector

Type	Spare Parts	Part no.
SBX-C 1040x200 35 O10O10S05 SEM-150	Sealing plate (SBX) DI-PL 1040x200 35 O10O10S05	10.01.20.01006
SBX-C 1250x200 35 O10O10S05 SEM-150	Sealing plate (SBX) DI-PL 1250x200 35 O10O10S05	10.01.20.00438

## Technical Data Area Gripping Systems SBX-C with Ejector

Type*	Vacuum generation	Number of suction cells	Air consumption [l/min]	Suction rate (max) [l/min]	Degree of evacuation [%]	Suction force [N]**	Weight [kg]
SBX-C 1040x200 35 O10O10S05 SEM-150	Ejector	29	640.0	1,400	80	2,400	25
SBX-C 1250x200 35 O10O10S05 SEM-150	Ejector	35	640.0	1,400	80	3,000	28

\*Sound level 78 dB(A)

\*\*At -0.25 bar and with the gripper fully covered by a workpiece typical for the application (wooden board with structured surface)

# Area Gripping Systems SBX-C with Ejector

Suction area (LxW) from 1,040 x 200 mm to 1,250 x 200 mm



## Design Data Area Gripping Systems SBX-C with Ejector

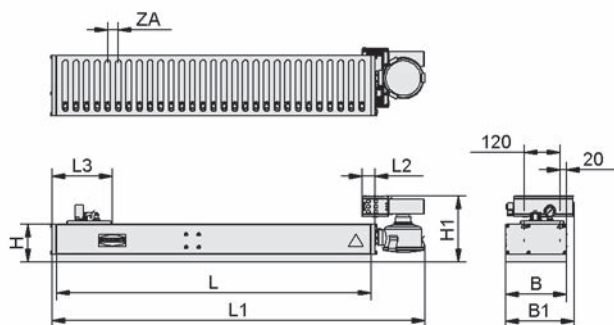

SBX-C

Type*	B [mm]	B1 [mm]	H [mm]	H1 [mm]	L [mm]	L1 [mm]	L2 [mm]	L3 [mm]	ZA [mm]
SBX-C 1040x200 35 O10O10S05 SEM-150	200	226	125	217	1,040	1,234	41	198	35
SBX-C 1250x200 35 O10O10S05 SEM-150	200	226	125	217	1,250	1,444	41	198	35

\*Type SBX-C requires compressed air hose 15/9 mm



- Schmalz - The Company
- Vacuum Suction Cups
- Special Grippers
- Gripping Systems
- Clamping Systems
- Mounting Elements
- Vacuum Generators
- Valve Technology
- Switches and Monitoring
- Filters and Connections
- Services
- Contact
- Glossary
- Index of Products

# Area Gripping Systems SBX-C without Ejector

Suction area (LxW) from 1,040 x 200 mm to 1,250 x 400 mm

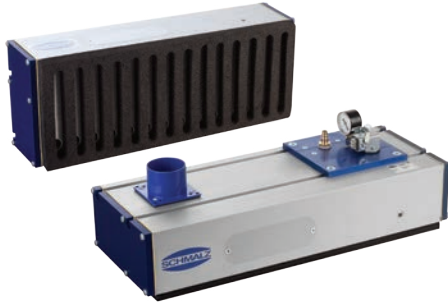

Area Gripping Systems SBX-C without Ejector

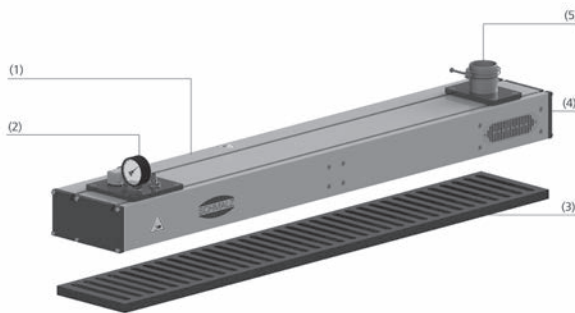

System Design Area Gripping Systems SBX-C without Ejector

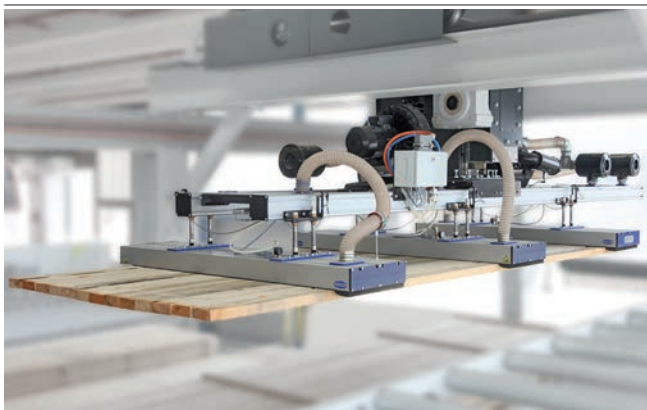

Area Gripping Systems SBX-C on an industrial gantry for handling unplanned wooden boards

## Suitability for Industry Specific Applications

### Applications

- Robust gripper with connection for external vacuum generation, for powerful handling of lumber, planed or glued timber, sheet materials, pallets, crate elements
- Handling of naturally grown materials with knots or cracks or with warped, rough surfaces
- Ideal for the rough application conditions in sawmills or in woodworking and furniture construction
- As double gripper configuration also suitable for unstacking and transporting workpieces in layers
- Ideal for operation with industrial robots and gantries due to its low weight and compact dimensions

### Design

- Aluminum basic profile (1) with integrated vacuum reservoir
- Compact valve units (2) with control valves, vacuum gauges and electrical and pneumatic connections; valve unit is removable
- Sealing foam (3) rebounds quickly and resistant to wear thanks to its sandwich design, with quick-change adhesive film
- End cover (4)
- Connecting (5) for external vacuum generation

### Our Highlights...

- Connection for electrical vacuum generators (blower or pump)
- Unused suction cells are switched off automatically
- Wear-resistant sealing foam with adhesive film
- Compact valve unit

### Your Benefits...

- High flow rates and vacuum power up to -0.8 bar; low operating costs
- System pressure is maintained even when partially covered
- Long service life and low maintenance costs due to easy removal of sealing foam
- Maintenance-friendly due to easy removal



# Area Gripping Systems SBX-C without Ejector

Suction area (LxW) from 1,040 x 200 mm to 1,250 x 400 mm

## Designation Code Area Gripping Systems SBX-C without Ejector

<b>SBX</b>	-	<b>C</b>	-	<b>1040x200</b>	-	<b>35</b>	-	<b>O10O10S05</b>	-	<b>SGBL</b>
<b>1</b>		<b>2</b>		<b>3</b>		<b>4</b>		<b>5</b>		<b>6</b>

### 1 – Abbreviated designation

Code	Version
SBX	SBX

### 2 – Valve unit

Code	Version
C	Integrated compact valve unit

### 3 – LxW

Code	LxW in mm
1040x200	1040x200
1250x200	1250x200
1040x400	1040x400
1250x400	1250x400

### 4 – Hole spacing

Code	Spacing in mm
35	35

### 5 – Sealing element

Code	Height in mm
O10O10S05	25

### 6 – Vacuum generation

Code	Version
SGBL	For external vacuum generation

Gripping system SBX-C is delivered as a ready-to-connect product.

Available spare parts: sealing plate

## Ordering Data Area Gripping Systems SBX-C without Ejector

Type	Part no.
SBX-C 1040x200 35 O10O10S05 SGBL	10.01.20.01002
SBX-C 1250x200 35 O10O10S05 SGBL	10.01.20.01003
SBX-C 1040x400 35 O10O10S05 SGBL	10.01.20.01004
SBX-C 1250x400 35 O10O10S05 SGBL	10.01.20.01005

## Ordering Data Spare Parts Area Gripping Systems SBX-C without Ejector

Type	Spare Parts		Part no.
SBX-C 1040x200 35 O10O10S05 SGBL	Sealing plate (SBX)	DI-PL 1040x200 35 O10O10S05	10.01.20.01006
SBX-C 1250x200 35 O10O10S05 SGBL	Sealing plate (SBX)	DI-PL 1250x200 35 O10O10S05	10.01.20.00438
SBX-C 1040x400 35 O10O10S05 SGBL	Sealing plate (SBX)	DI-PL 1040x400 35 O10O10S05	10.01.20.01007
SBX-C 1250x400 35 O10O10S05 SGBL	Sealing plate (SBX)	DI-PL 1250x400 35 O10O10S05	10.01.20.00440

## Technical Data Area Gripping Systems SBX-C without Ejector

Type	Vacuum generation	Number of suction cells	Suction force [N]*	Weight [kg]
SBX-C 1040x200 35 O10O10S05 SGBL	Blower / Pump	29	2,400	23
SBX-C 1250x200 35 O10O10S05 SGBL	Blower / Pump	35	3,000	26
SBX-C 1040x400 35 O10O10S05 SGBL	Blower / Pump	57	4,500	46
SBX-C 1250x400 35 O10O10S05 SGBL	Blower / Pump	69	5,900	52

\*At -0.25 bar and with the gripper fully covered by a workpiece typical for the application (wooden board with structured surface)

Schmalz – The Company  
Vacuum Suction Cups  
Special Grippers  
Gripping Systems  
Clamping Systems  
Mounting Elements  
Vacuum Generators  
Valve Technology  
Switches and Monitoring  
Filters and Connections  
Services  
Contact  
Glossary  
Index of Products

# Area Gripping Systems SBX-C without Ejector

Suction area (LxW) from 1,040 x 200 mm to 1,250 x 400 mm



## Design Data Area Gripping Systems SBX-C without Ejector

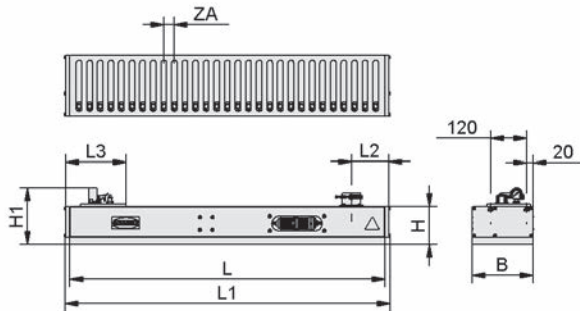

SBX-C

Type*	B1 [mm]	H [mm]	H1 [mm]	L [mm]	L1 [mm]	L2 [mm]	L3 [mm]	ZA [mm]
SBX-C 1040x200 35 O10O10S05 SGBL	200	125	208	1,040	1,075	123	198	35
SBX-C 1250x200 35 O10O10S05 SGBL	200	125	208	1,250	1,276	123	198	35
SBX-C 1040x400 35 O10O10S05 SGBL	400	125	208	1,040	1,075	123	198	35
SBX-C 1250x400 35 O10O10S05 SGBL	400	125	208	1,250	1,276	123	198	35

\*Vacuum hose with internal diameter 60 mm required

# Vacuum Layer Gripping Systems and Suction Spiders

## Vacuum Layer Gripping Systems SPZ



Powerful Solution for a Wide Range of Palletizing Tasks



Vacuum layer gripping system SPZ handling buckets

### Application

- Palletizing and de-palletizing various goods
- Use in warehouses and intra-logistics
- Integration in the periphery via mechanical, power and control technology interfaces
- Handling partial pallets and mixed layers

### Your Benefits

- Reliable and damage-free gripping of different layer sizes and layer arrangements
- Intelligent mechanical, power and software interfaces
- Innovative gripping concept with mechanical support for additional holding force

### Design

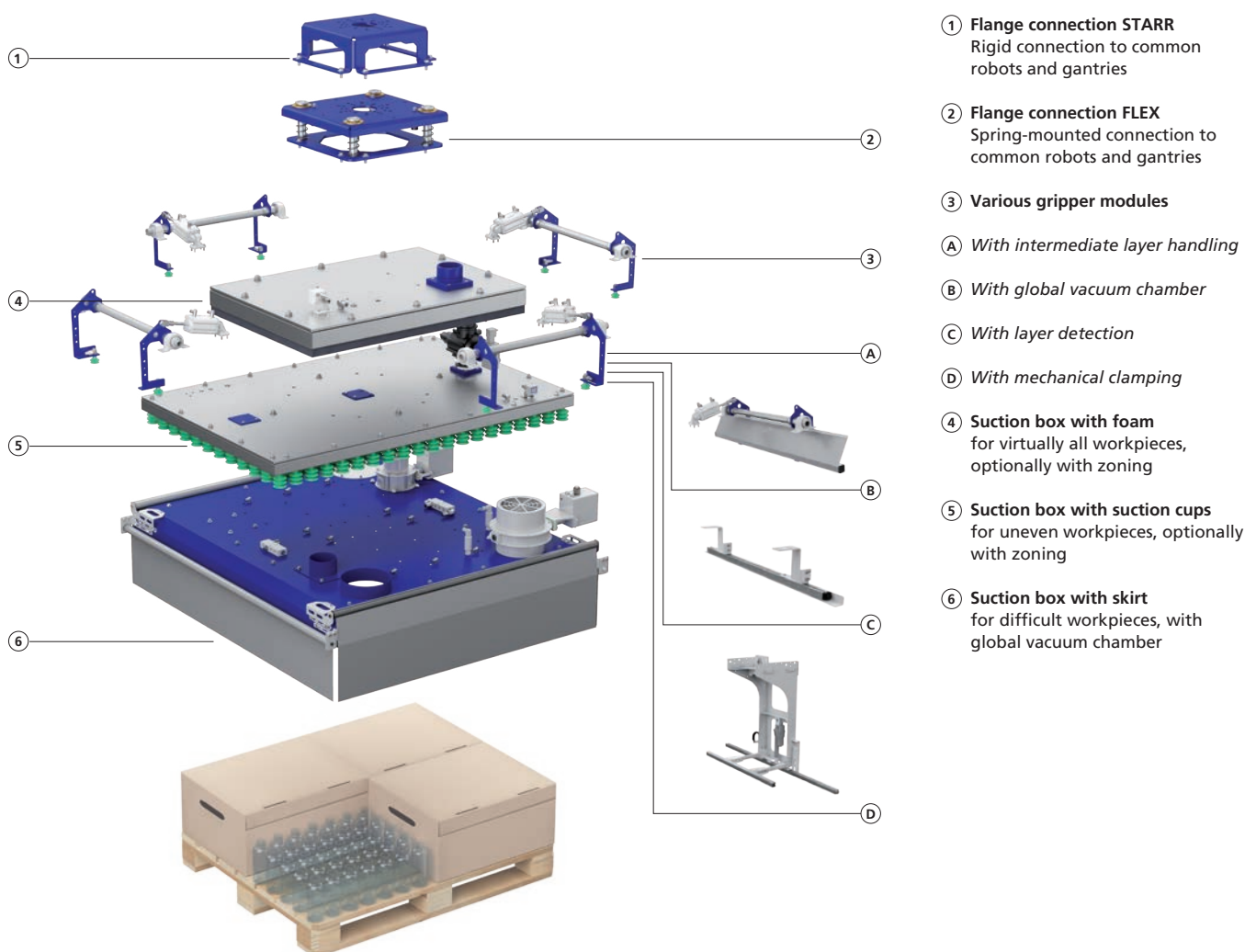

System design of the vacuum layer gripping system SPZ



Schmalz – The Company  
Vacuum Suction Cups  
Special Grippers  
Gripping Systems  
Clamping Systems  
Mounting Elements  
Vacuum Generators  
Valve Technology  
Switches and Monitoring  
Filters and Connections  
Services  
Contact  
Glossary  
Index of Products

# Vacuum Suction Spiders SSP

Custom-Made Solutions for End-of-Arm Tooling

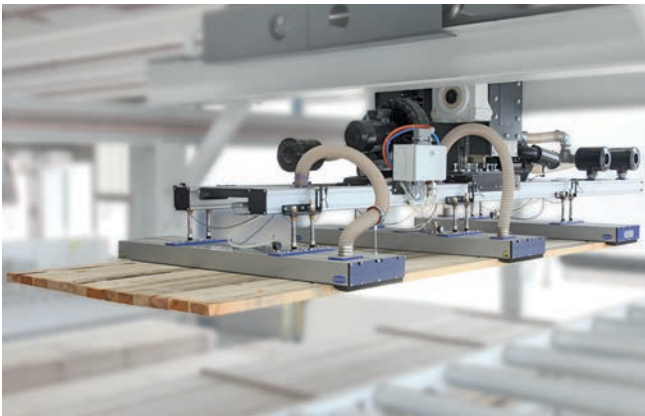

Vacuum suction spider SSP handling wooden boards

## Application

- Automation of manufacturing and assembly processes
- Interlinking of robots in presses and bending centers
- Loading of machine tools, wood working centers, water jet cutters, laser cutters and punching machines
- Handling of car body parts, bricks and boards/panels

## Your Benefits

- Modular system of standardized, optimally coordinated individual components
- Different gripping concepts can be combined
- Low weight thanks to FEM-optimized basic design and consistent lightweight construction

## Design

### Connections, interfaces and distributors

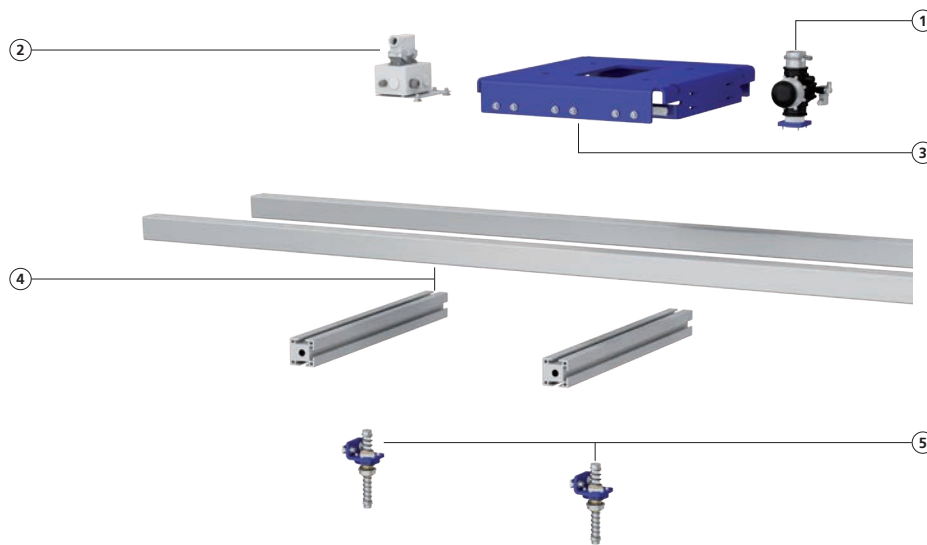

- 1 Vacuum valve**  
Pneumatic interface
- 2 Terminal box**  
Electronic interface
- 3 Flange connection**  
Mechanical interface for common robots and gantries
- 4 Mounting sections**  
Used as load beam and vacuum distributor
- 5 Flexible suspension**  
Spring-mounted connection suitable for workpieces with height differences

### Grippers

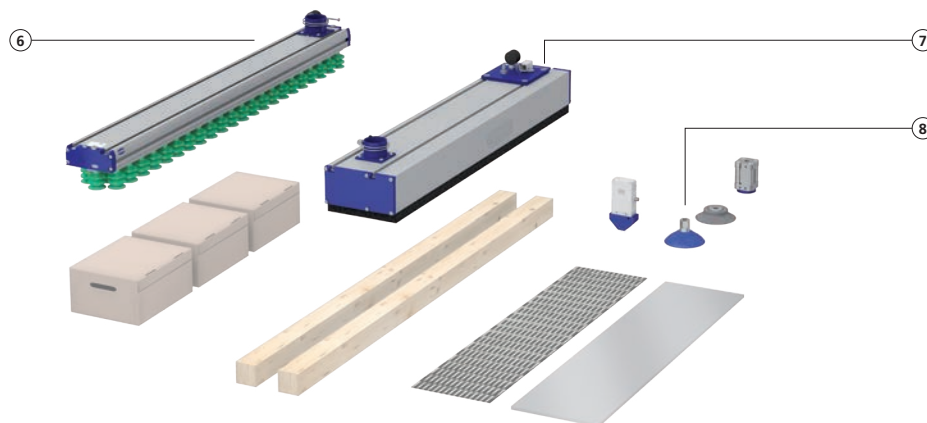

- 6 Gripping system (FMP/FXP) with suction cups**  
For handling uneven and non-rigid workpieces
- 7 Gripping system (SBX-C) with foam**  
For handling heavy and rough workpieces
- 8 Grippers with different gripping principles**  
For handling a wide range of workpieces (e.g. magnetic grippers for handling perforated plates or needle grippers for CFRP materials)

System design of the vacuum suction spider SSP

Schmalz –  
The Company

Vacuum  
Suction Cups

Special  
Grippers

Gripping  
Systems

Clamping  
Systems

Mounting  
Elements

Vacuum  
Generators

Valve  
Technology

Switches and  
Monitoring

Filters and  
Connections

Services

Contact

Glossary

Index of  
Products

# Vacuum End Effectors VEE

Configuring Rather than Designing



## Suitability for Industry Specific Applications

### Application

- Fast and cost-effective design of vacuum end effectors for highspeed packaging processes
- Pick-and-place applications with Delta, SCARA and articulated robots
- Fully automated filling of cardboard boxes and case packers
- Mainly used in primary and secondary packaging processes
- Transporting products into top-loading machines, and cardboard box and tray erectors
- Use in flexible packaging machines with frequent format changes



The vacuum end effector with vacuum module and bellows suction cups SPB1 handling flexible packages

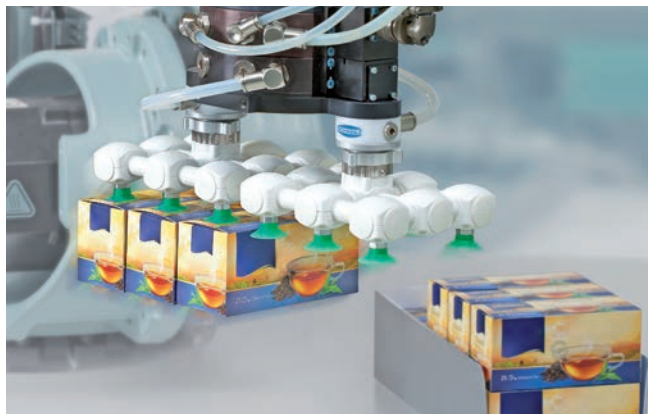

Vacuum end effector with flat suction cups SPF handling boxes of tea



The vacuum end effector with bellows suction cups SPB4f handling pouches with strong wrinkling and low filling degree

### Our highlights...

- Perfectly coordinated individual components
- Online configurator with generation of CAD data and parts list
- Light weight (ready-to-connect end effectors starting at 150 g)
- FDA and BfR compliant (German Federal Institute for Risk Assessment) high performance thermoplastic
- With optional integrated vacuum generation using the Schmalz eco nozzle technology
- Assembly service

### Your benefits...

- Flexible gripper configurations with variable suction cup number and positioning
- Minimizes configuration and setup times by more than 80 %
- Designed for high-speed applications with accelerations of up to 10 g (100 m/s<sup>2</sup>)
- Excellent resistance to alkaline cleaning agents
- Fast, energy-efficient vacuum generation right at the gripper
- Delivery of entire assembled, ready-to-connect vacuum end effectors



Schmalz – The Company  
Vacuum Suction Cups  
Special Grippers  
Gripping Systems  
Clamping Systems  
Mounting Elements  
Vacuum Generators  
Valve Technology  
Switches and Monitoring  
Filters and Connections  
Services  
Contact  
Glossary  
Index of Products



# Vacuum End Effectors VEE

Configuring Rather than Designing

## Design

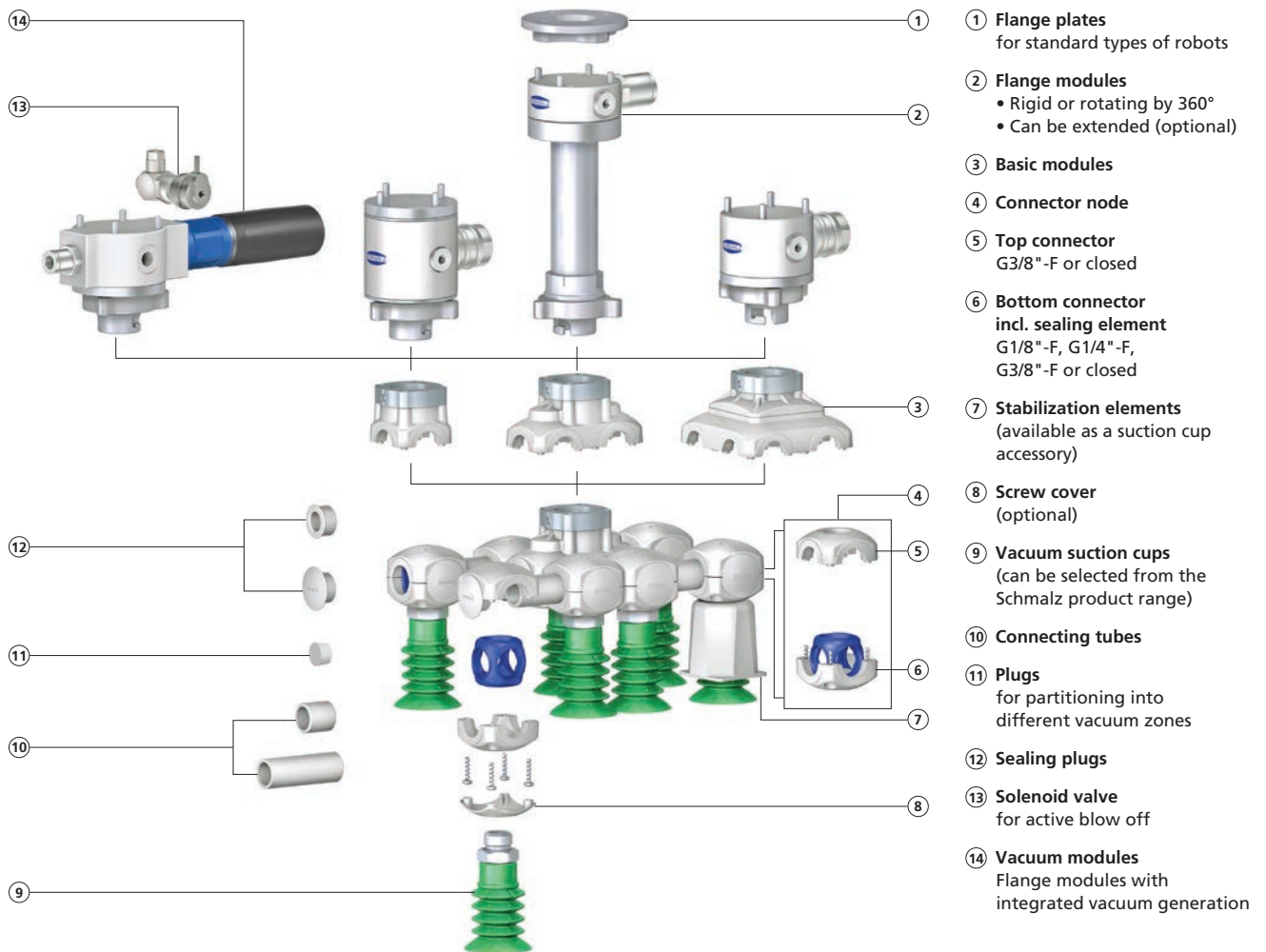

Schmalz – The Company  
 Vacuum Suction Cups  
 Special Grippers  
 Gripping Systems  
 Clamping Systems  
 Mounting Elements  
 Vacuum Generators  
 Valve Technology  
 Switches and Monitoring  
 Filters and Connections

### VEE OnlineConfigurator

- Live 3D preview of the configuration
- Creation of a 3D PDF data sheet including a parts list and CAD data
- Simple importing in your consisting construction
- Quick request for proposal (RFP)

[WWW.SCHMALZ.COM/VEE](http://WWW.SCHMALZ.COM/VEE)

Services  
 Contact  
 Glossary  
 Index of Products

# Vacuum End Effectors VEE

Configuring Rather than Designing

## Components VEE

Schmalz – The Company

Vacuum Suction Cups

Special Grippers

Gripping Systems

Clamping Systems

Mounting Elements

Vacuum Generators

Valve Technology

Switches and Monitoring

Filters and Connections

Services

Contact

Glossary

Index of Products

<p><b>Flange plates FLAN-PL</b> Quick and easy connection of the flange module to the robot; available for common robot types and as an universal flange.</p>	<p><b>Flange modules VEE-QCM</b> Quick-change adapters and vacuum connection; either horizontal or vertical (max. flow rate 60 m³/h). Alternative: rotary unit VEE-RU for continuous rotation of the end effector without decreasing the flow or winding up the hose.</p>	<p><b>Vacuum modules VEE-QCMV</b> Quick-change adapters with space-saving integrated, energy-efficient vacuum generation using the Schmalz ecoPump (max. suction rate: 10.5 m³/h); with silencer or holder cap.</p>	<p><b>Solenoid valve EMV for active blow off</b> Minimal cycle times with active blow off through a controlled compressed air pulse; available as an accessory for vacuum module VEE-QCMV.</p>
<p><b>Flange extensions VEE-FE</b> Option for flange modules for dipping into cardboard boxes or trays; available in three lengths. Can be swapped quickly thanks to the bayonet mount.</p>	<p><b>Basic modules VEE-QCF</b> Tool-free connection of the end effector to the flange module and central vacuum feed; available as a 1-, 2-, or 4-connection module.</p>	<p><b>Top connector VEE-CO-U</b> Top half-shell for assembly of connection nodes; available in closed design or with connection for additional vacuum feed (G3/8"-F).</p>	<p><b>Bottom connector VEE-CO-L</b> Bottom half-shell including sealing element and screws for assembly of connecting nodes; either closed or with connection for suction cup (G1/8"-F, G1/4"-F, G3/8"-F); optional screw cover available.</p>
<p><b>Connection tubes VEE-TU</b> Vacuum guide and variable connection of nodes; available in 18 mm and 200 mm lengths. Pipe scissors for quick and safe cutting available as accessory.</p>	<p><b>Plugs VEE-PL</b> For sealing unused connections on connector nodes, vacuum feed on the side and partitioning into different vacuum zones.</p>	<p><b>Stabilization elements SPSE</b> Increases process speed by supporting the workpiece; available as an accessory for bellows suction cups.</p>	<p><b>Tool center point VEE-TCP</b> For determining the robot tool position with a center point that can be flange mounted directly; suitable for the quick-change interfaces of the flange modules or vacuum modules.</p>

# Vacuum End Effectors VEE

Configuring Rather than Designing



## Technical Data

Specification	Vacuum end effectors from the VEE system
Max. rated flow	60 m³/h
Max. vacuum value	-980 mbar
Overpressure resistance	up to 3 bar
Temperature range	-25° C to +80° C (QCMV 0° C to +60° C)
Material	High performance thermoplastic (compliant with FDA guidelines)
Max. load capacity	2,000 g



## Design Data

Vacuum end effectors VEE can be freely configured within the framework values. When used in connection with our wide selection of suction cups, the possibilities are practically endless.

Specifications	Vacuum end effectors from the VEE system	
	Minimum configuration	Maximum configuration
Basic module	1 connection	4 connection
Suction cups connection thread	G1/8"-F, G1/4"-F, G3/8"-F	G1/8"-F, G1/4"-F, G3/8"-F
Gripper size (LxW)	38 x 38 mm	300 x 200 mm
Weight*	65 g	500 g
Qty. of suction cups	1	12
Workpiece sizes (LxW)	15 x 15 mm	400 x 300 mm

\*without flange module and suction cup

## VEE Starter Set

Whether for use directly in a robotic system or as a handy design tool; with the VEE Starter Set you have all of the most important components for quickly assembling your effector right at your fingertips.

### Content

120-piece starter set with all of the components necessary for installing up to two VEE vacuum end effectors, including:

- 8 vacuum suction cups SPB4f-30 for bags and flexible packaging
- Lockable quick-change adapter with bayonet mount

Supplied in a sturdy plastic case with detailed assembly instructions  
Part no.: 10.01.36.00030



VEE Starter Set



# Vacuum Clamping Systems

Schmalz –  
The Company

Vacuum  
Suction Cups

Special  
Grippers

Gripping  
Systems

**Clamping  
Systems**

Mounting  
Elements

Vacuum  
Generators

Valve  
Technology

Switches and  
Monitoring

Filters and  
Connections

Services

Contact

Glossary

Index of  
Products



At a Glance

## Clamping Systems for Console Table Systems

		Page	Schmalz – The Company
	<b>Clamping Equipment for Schmalz Consoles (single-circuit)</b> <ul style="list-style-type: none"> <li>• For 1-circuit vacuum systems</li> <li>• Hose-free</li> <li>• Pre-fixation with guide strips</li> </ul>	335	Vacuum Suction Cups
	<b>Clamping Equipment for Schmalz Consoles (two-circuit)</b> <ul style="list-style-type: none"> <li>• For 2-circuit vacuum systems</li> <li>• Hose-free</li> <li>• Pre-fixation with vacuum</li> </ul>	336	Special Grippers
	<b>Clamping Equipment for Biesse Consoles*</b> <ul style="list-style-type: none"> <li>• Hose-free vacuum system</li> <li>• Integrated touch valve</li> <li>• Pre-fixation in the suction block mounting</li> </ul>	337	Gripping Systems
	<b>Clamping Equipment for SCM / Morbidelli Consoles*</b> <ul style="list-style-type: none"> <li>• Hose-free vacuum system</li> <li>• Integrated touch valve</li> <li>• Mechanical pre-fixation</li> </ul>	338	Clamping Systems

## Clamping Systems for Grid Table Systems

	<b>Clamping Equipment for Grid Tables</b> <ul style="list-style-type: none"> <li>• For all common grid tables</li> <li>• Fixation via positioning inserts</li> <li>• Integrated touch valve</li> </ul>	339	Mounting Elements
--	--------------------------------------------------------------------------------------------------------------------------------------------------------------------------------------------------------	-----	-------------------

## Modernization of CNC Machining Centers

	<b>Innospann Steel-Plate ISST</b> <ul style="list-style-type: none"> <li>• Steel-Plate with vacuum openings for flexibly positioning of the clamping equipment</li> </ul>	340	Vacuum Generators
--	---------------------------------------------------------------------------------------------------------------------------------------------------------------------------	-----	-------------------

## Clamping Systems for Flat Table Systems

	<b>Vacuum Blocks VCBL-G</b> <ul style="list-style-type: none"> <li>• For flat tables with 2-circuit vacuum system</li> <li>• Pre-fixation and fixation with vacuum</li> </ul>	341	Vacuum Technology
--	-------------------------------------------------------------------------------------------------------------------------------------------------------------------------------	-----	-------------------

# Overview of Section

## At a Glance

Schmalz – The Company  
Vacuum Suction Cups  
Special Grippers  
Gripping Systems  
Clamping Systems  
Mounting Elements  
Vacuum Generators  
Valve Technology  
Switches and Monitoring  
Filters and Connections  
Services  
Contact  
Glossary  
Index of Products

Page



### Vacuum Blocks VCBL-GL

- Two-circuit vacuum system with hose connection
- Fixation and positioning with vacuum



Vacuum block for use on flat tables of Bando Kiko\* for gently clamping moist, dry or thin glass.

342

## Quick-Change-Systems

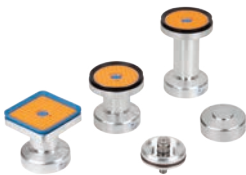

### Schmalz Quick-Change SQC

- Three-part quick-change system
- Hose-free vacuum line
- Fits machine tables with M12 vacuum feeds



Quick-change system SQC for use on glass grinding machines.

343

## Clamping Solutions for Manual Processing



### Multi-Clamp VC-M

- System consists of suction plate and rotation / swiveling unit Multi-Base
- Internal or external vacuum supply possible



Vacuum clamping system Multi-Clamp to fix workpieces for manual work.

344

## Clamping System Matrix-Plate

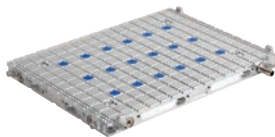

### Matrix-Plate MPL

- Clamping system made of high-strength aluminum
- Optional friction pads (RI) for 30 % greater shear force absorption

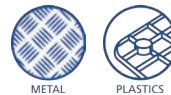

Clamping solution for use in precise clamping of flat workpieces with smooth surfaces, for low-vibration machining.

345

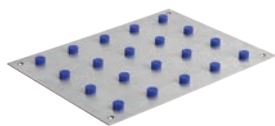

### Innospann Steel-Plate Systems ISST-MPL

- Extension of the matrix plate for workpiece openings and 5-axis machining
- Dimensional accuracy of  $\pm 0.05$  mm



Modular system specially adapted for use on CNC machines in wet machining.

346

## Flexible Clamping Systems



### Basic Holding Fixture BHF

- Flexible, manually adjustable clamping solution for free-form workpieces
- Pre-fastening using vacuum or magnets



Clamping solution for use in machining, measuring, or mounting three-dimensional parts.

347

\*Biesse, Bando Kiko, Bystronic and SCM/Morbidelli are registered and protected trademarks. The articles listed here are products of J. Schmalz GmbH that have been designed to fit CNC machining centers from these manufacturers.

# Clamping Equipment for Schmalz Consoles (single-circuit)

Height 50 mm, 100 mm and 125 mm



Clamping Equipment for Schmalz Consoles (single-circuit)

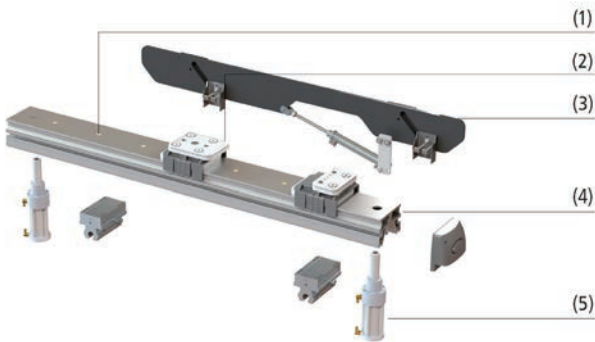

System Design Clamping Equipment for Schmalz Consoles (single-circuit)

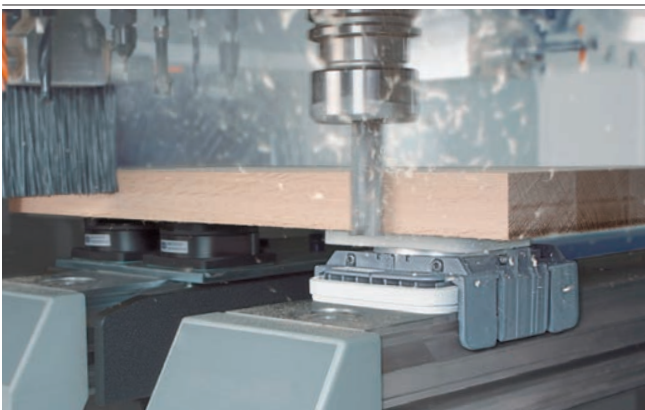

Vacuum Block VCBL-K1 being used for clamping wooden workpieces

## Suitability for Industry Specific Applications

### Applications

- Hose-free vacuum clamping system for CNC machining centers with console table (1-circuit system)
- Enables damage-free clamping with the highest precision and holding force
- Vacuum blocks are pre-fixed to the consoles via guide strips and secured against movement during setup
- Vacuum is used to clamp the vacuum blocks to the console and the workpiece to the vacuum blocks

### Design

- Schmalz Console (4) with hose free 1-circuit vacuum system (1)
- Mechanical prefixation of the vacuum block e.g. VCBL-K1 (2) on the console via guiding rails
- Panel lifting rail (3) for gentle loading and unloading of the CNC machining center
- Stop cylinder (5) of Schmalz for positioning of the workpiece

### Our Highlights...

- Enormous holding forces
- Dimensional accuracy
- Wide range of different vacuum blocks
- Replacement suction plates

### Your Benefits...

- Highest absorption of shear forces
- Enables highest accuracy in the production process
- Maximum flexibility and set-up time reduction
- Fast, easy and cost effective replacement of suction plates

# Clamping Equipment for Schmalz Consoles (two-circuit)

Height 50 mm, 75 mm, 100 mm and 125 mm



## Suitability for Industry Specific Applications

### Applications

- Hose-free vacuum clamping system for CNC machining centers with console table (2-circuit system)
- The vacuum blocks are pre-fixed to the consoles and secured against movement during setup
- Safe and precise clamping of the workpiece and the vacuum blocks on the console with the second vacuum
- The optional touch valve (TV) enables unused vacuum blocks to remain on the machine table



Clamping Equipment for Schmalz Consoles (two-circuit)

### Design

- Clamping console (4) with hose free 2-circuit vacuum system (1)
- Prefixation of the vacuum blocks e.g. VCBL-K2 (2) via vacuum
- Panel lifting rail (3) for gentle loading and unloading of the CNC machining center
- Stop cylinder (5) by Schmalz for positioning the workpiece

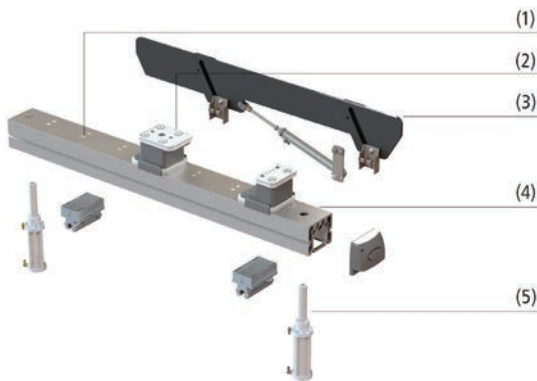

System Design Clamping Equipment for Schmalz Consoles (two-circuit)



Vacuum block VCBL-K2 while clamping a workpiece

### Our Highlights...

- Enormous holding forces
- Dimensional accuracy
- Wide range of different vacuum blocks
- Replacement suction plates

### Your Benefits...

- Highest absorption of shear forces
- Enables highest accuracy in the production process
- Maximum flexibility and set-up time reduction
- Fast, easy and cost effective replacement of suction plates



Schmalz – The Company  
Vacuum Suction Cups  
Special Grippers  
Gripping Systems  
Clamping Systems  
Mounting Elements  
Vacuum Generators  
Valve Technology  
Switches and Monitoring  
Filters and Connections  
Services  
Contact  
Glossary  
Index of Products



# Clamping Equipment for Biesse Consoles\*

Height 29 mm, 48 mm and 74 mm



Clamping Equipment for Biesse Consoles

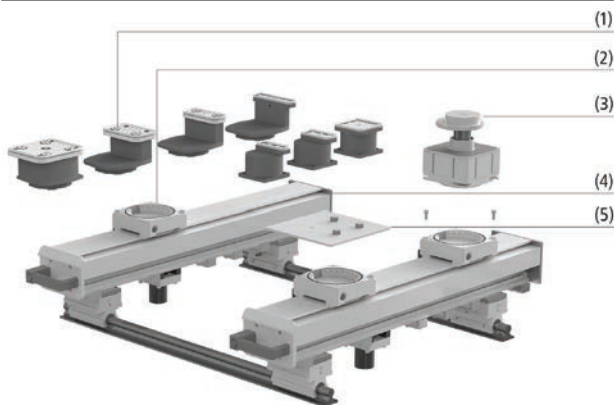

System Design Clamping Equipment for Biesse Consoles

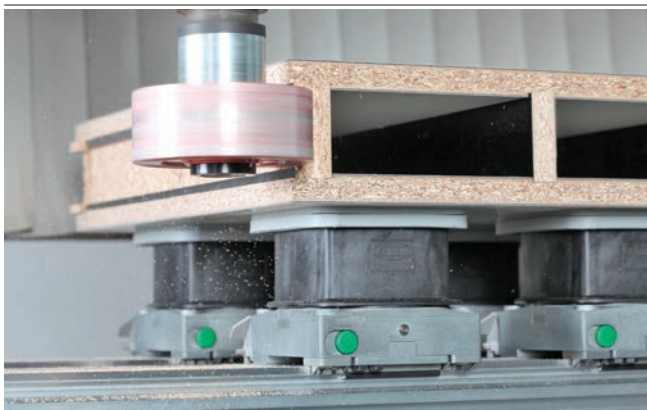

Vacuum block VCBL-B for gripping particle boards

## Suitability for Industry Specific Applications

### Applications

- Hose-free vacuum clamping system from Schmalz for console tables from Biesse (single-circuit system)
- Fully compatible with the OEM vacuum blocks
- The vacuum blocks can be inserted in any direction in 15° increments in the standard mountings
- Clamping straps on the vacuum block ring and magnets ensure secure fixation in the vacuum block mounting
- Heights of 29 mm and 48 mm (for 3 and 4-axis machines) and 74 mm (for 5-axis machines)
- An integrated touch valve (TV) automatically activates the vacuum when the workpiece is applied – any unused vacuum blocks can remain in the mounting

### Design

- Vacuum block VCBL-B (1) in various geometries
- Biesse standard vacuum block mounting (2)
- Mechanical clamp (3)
- Console of CNC machining centers produced by the Italian manufacturer Biesse (4)
- Adapter-Plate ISAP-B with suction cups (5)

### Our Highlights...

- Very high holding forces
- Fast and easy positioning (rotatable in 15° steps in the suction cup mounting)
- High dimensional accuracy
- Replacement suction plates are individually exchangeable

### Your Benefits...

- Extremely high resistance to lateral forces
- Shortening of down times
- Enables highest precision during machining process
- Quick repair of damaged suction plates and reduced spare parts costs

\*Biesse is a registered and protected trademark. The articles listed here are products of J. Schmalz GmbH that have been designed to fit CNC machining centers from Biesse.



# Clamping Equipment for SCM / Morbidelli Consoles\*

Height 32.7 mm and 50 mm



## Suitability for Industry Specific Applications

### Applications

- Hose-free vacuum clamping system from Schmalz for console tables from SCM / Morbidelli, fully compatible with OEM vacuum blocks
- The vacuum blocks are pre-fixed to the console
- An integrated touch valve (TV) enables unused vacuum blocks to remain on the machine table
- TV system from SCM = S1 system from Schmalz (width of the console 76.5 mm)
- TVS system from SCM = S1 system from Schmalz with hose connection (width of the console 76.5 mm)
- TVN System from SCM = S4 System from Schmalz (width of the console 110 mm)

### Design

- Vacuum block (1) with mechanical pre-fastening on the console and touch valve
- Guide strips on the suction cup (2) for pre-fastening on the console
- Hose-free vacuum line via touch valves (3) in the console
- Specially developed and adapted for the consoles (4) of the Italian machine manufacturer SCM

- Schmalz – The Company
- Vacuum Suction Cups
- Special Grippers
- Gripping Systems
- Clamping Systems
- Mounting Elements
- Vacuum Generators
- Valve Technology
- Switches and Monitoring
- Filters and Connections
- Services
- Contact
- Glossary
- Index of Products



Clamping Equipment for SCM / Morbidelli Consoles

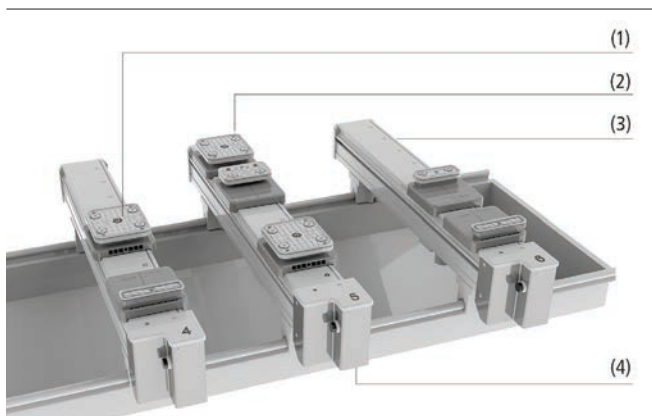

System Design Clamping Equipment for SCM / Morbidelli Consoles



Vacuum block VCBL-S4 used with SCM consoles

### Our Highlights...

- Enormous holding forces
- Dimensional accuracy
- Wide range of different vacuum blocks
- Replacement suction plates

### Your Benefits...

- Highest absorption of shear forces
- Enables highest accuracy in the production process
- Maximum flexibility and set-up time reduction
- Fast, easy and cost effective replacement of suction plates

\* SCM / Morbidelli is a registered and protected trademark. The articles listed here are products of J. Schmalz GmbH that have been designed to fit CNC machining centers from SCM / Morbidelli.

# Clamping Equipment for Grid Tables

Height 25 mm, 45 mm and 125 mm



Clamping Equipment for Grid Tables

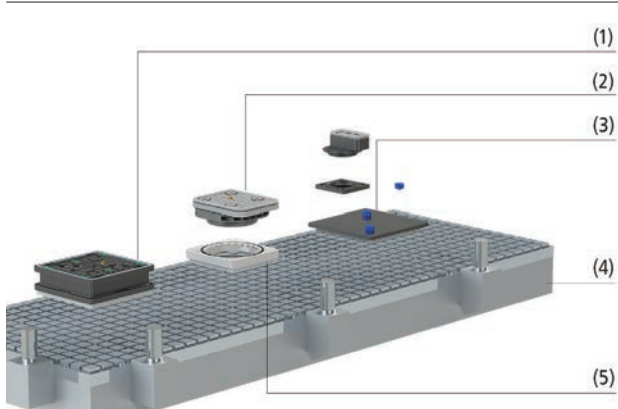

System Design Clamping Equipment for Grid Tables



Vacuum block VCBL-R for gripping particle boards

## Suitability for Industry Specific Applications

### Applications

- Vacuum clamping system for CNC machining centers with grid table
- Suitable for all common grid geometries (slot width 6 mm to 7.5 mm, slot depth 6 mm to 7 mm)
- Suitable for complex five-axis processing, such as the production of recesses and the trimming of panels
- Simple and fast positioning of the vacuum blocks with the corresponding positioning inserts
- Safe and non-slip clamping of the workpiece with the special friction pad on the suction area

### Design

- Grid table of the CNC machine (4)
- Vacuum block for grid tables (1) overall heights 25 mm and 45 mm, suitable for all common grid geometries
- Adapter-plate AP-R (5) in connection with VCBL-B (2)
- Mini-plate ISMP-R (3) with Innospann cups for flexible clamping layouts and processing narrow parts

### Our Highlights...

- Enormous holding forces
- Dimensional accuracy
- Wide range of different types
- Differing overall heights available
- Versatile accessories and spare parts

### Your Benefits...

- Highest absorption of shear forces
- Enables highest accuracy in the production process
- Maximum flexibility and set-up time reduction
- Enables complex machining of the workpiece edges
- Fast, easy and cost effective replacement of accessories and spare parts

# Modernization of CNC Machining Centers

## Innospann Steel-Plate ISST



Hole grid measure 75 mm and 150 mm

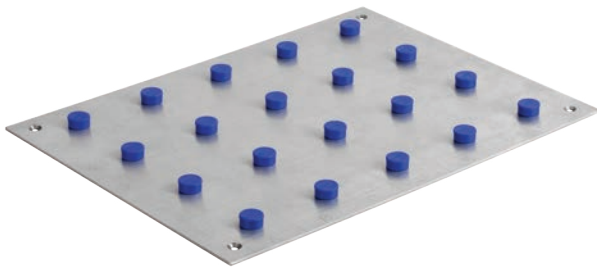

Innospann Steel-Plate ISST

### Suitability for Industry Specific Applications

#### Applications

- Vacuum clamping system for retrofitting CNC machining centers with flat, grid or console tables
- Facilitates efficient and flexible single piece and small series production especially for the manufacture of furniture
- The suction cup mountings Mono-Base and Quad-Base are fitted with suction cups and can be positioned freely on the Steel-Plate
- A laser grid provides orientation assistance
- Unused vacuum openings can be closed manually using sealing magnets
- Variable total height through various suction cup heights and optional spacer rings

#### Design

- Innospann Steel-Plate (1) made from high-quality stainless or galvanized steel with integrated vacuum openings
- Unused vacuum openings can be closed with sealing magnets (2)
- Suction cup mountings (4): Mono-Base or Quad-Base
- Suction cups (3) in various shapes
- Grid table (5) with sealing gasket or flat table (6) of machinery manufacturer

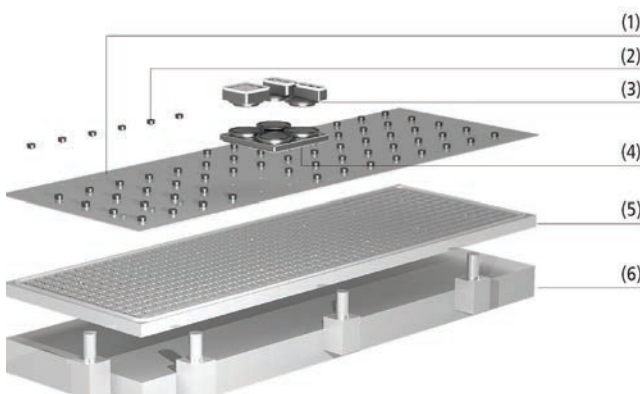

System Design Innospann Steel-Plate ISST



Innospann Steel-Plate with mono bases and suction cups

#### Our Highlights...

- Use on flat, grid and console tables
- Two different valve intervals available
- Laser etched grid markings
- Vacuum openings that are not covered can be sealed using sealing magnets

#### Your Benefits...

- Can be retrofitted on all standard machine types
- Enables free positioning of Mono-Bases and Quad-Bases
- Orientation assistance for suction cup positioning
- High level of flexibility and shortened set-up times

- Schmalz – The Company
- Vacuum Suction Cups
- Special Grippers
- Gripping Systems
- Clamping Systems
- Mounting Elements
- Vacuum Generators
- Valve Technology
- Switches and Monitoring
- Filters and Connections
- Services
- Contact
- Glossary
- Index of Products



# Vacuum Blocks VCBL-G

Height 75 and 100 mm



Vacuum Blocks VCBL-G

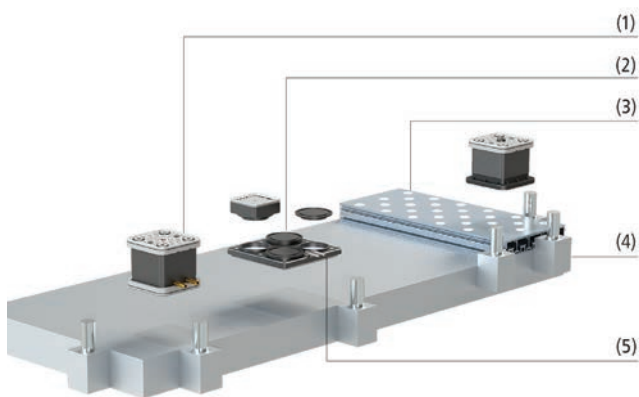

System Design Vacuum Blocks VCBL-G



Vacuum block VCBL-G for gripping particle boards

## Suitability for Industry Specific Applications

### Applications

- Universal vacuum clamping system with hose connection for CNC machining centers with flat table (2-circuit system)
- Hose nozzle diameter 10 mm
- Enables damage-free clamping with highest precision and holding force

### Design

- Flat table (4) of the CNC machining center
- Vacuum block VCBL-G (1) with 2-circuit hose system for flat tables, available with 75 mm or 100 mm height
- Innospann Quadbase ISQB-G (5) for use with various Innospann cups (2)
- Aluminum flat table (3) with magnetic valve technology for use with the VCBL-T series

### Our Highlights...

- Enormous holding forces
- Dimensional accuracy
- Wide range of different vacuum blocks
- Replacement suction plates

### Your Benefits...

- Highest absorption of shear forces
- Enables highest accuracy in the production process
- Maximum flexibility and set-up time reduction
- Fast, easy and cost effective replacement of suction plates



# Vacuum Blocks VCBL-GL

Height 81.5 mm and 93.5 mm



## Suitability for Industry Specific Applications

### Applications

- Vacuum block VCBL-GL for grinding glass workpieces on flat table machines made by Bando Kiko\*
- Grinding of building, design and automotive glass
- 2-circuit vacuum system with two hose connections for positioning on the machine table and simultaneous fixation of the workpiece

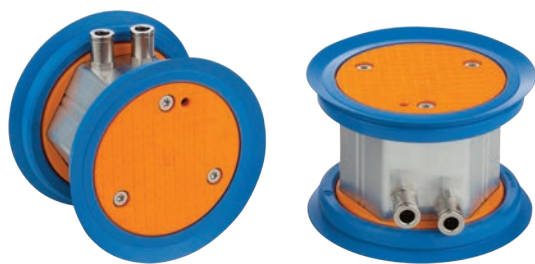

Vacuum Blocks VCBL-GL

### Design

- Sealing rings (1) made of low marking material
- Friction surface (2) made of wear resistant material
- Robust housing (3) made of aluminum
- Push-in fitting accessories (4) for hose connection of the vacuum system

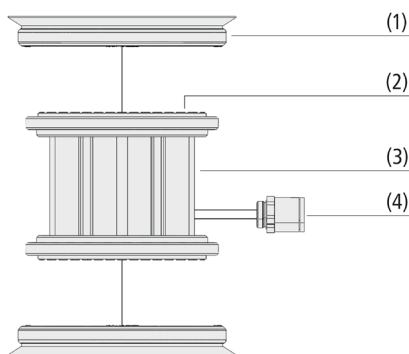

System Design Vacuum Blocks VCBL-GL

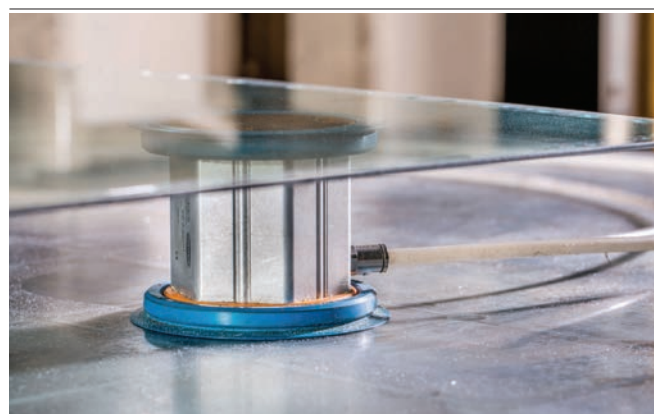

Vacuum block VCBL-GL clamping glass

### Our Highlights...

- High lateral force absorption through durable friction pad
- Replaceable sealing ring made of material HT1 leaving few marks and friction plate made of Elastodur
- Height tolerance  $\pm 0.05$  mm
- Low sealing lip return force

### Your Benefits...

- Extreme holding forces on dry or wet glass
- Mark-free workpiece surfaces
- High precision and dimensional accuracy
- No workpiece deformation

\*Bando Kiko is a registered trademark. The products listed here were developed by J. Schmalz GmbH to fit machines by this manufacturer.

# Schmalz Quick-Change SQC

Working heights 80 mm and 120 mm

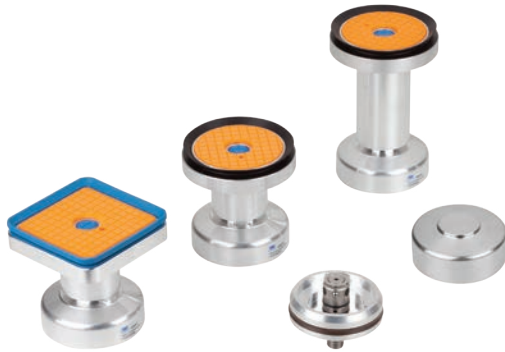

Schmalz Quick-Change SQC

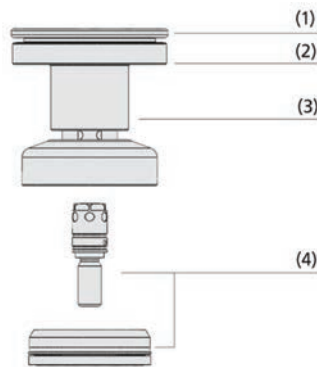

System Design Schmalz Quick-Change SQC

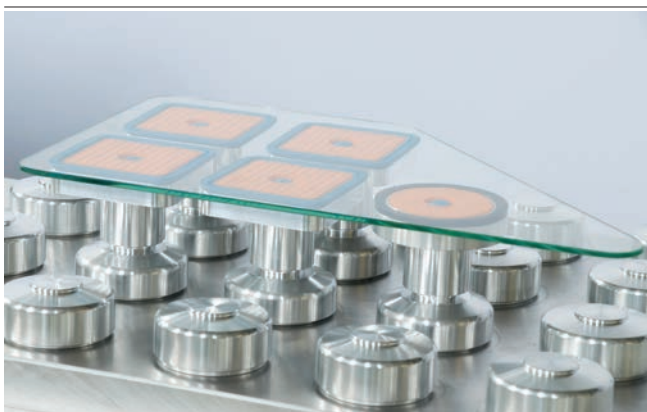

Schmalz Quick-Change SQC for clamping glass

## Suitability for Industry Specific Applications

### Applications

- Vacuum clamping system for grinding glass workpieces using CNC machines from the manufacturer Bystronic\*
- Tool-free replacement reduces set-up time and downtime
- Grinding of high quality designer and automotive glass
- Simple retrofitting on existing machine tables
- Working heights of 80 mm and 120 mm

### Design

- Sealing frame (1) made of a material leaving few marks
- Square and round suction areas available (2)
- Aluminum housing with break joint (3)
- Base with hollow bolt for long-term mounting on a machine table (4)

### Our Highlights...

- Modular quick-change system with only three parts
- Sealing frame replaceable without tools; made of HT1 material leaving few marks
- Base stays on the machine table permanently
- High absorption of lateral forces

### Your Benefits...

- Quick set-up processes of new machine layouts
- Mark free workpiece surface
- Low cleaning costs when changing layouts
- Very high holding force on dry or wet glass

\*Bystronic is a registered and protected trademark. The articles listed here are products of J. Schmalz GmbH that have been designed to fit CNC machining centers from Bystronic.



# Multi-Clamp VC-M

Vacuum generation integrated using ejector or external using vacuum pump

- Schmalz – The Company
- Vacuum Suction Cups
- Special Grippers
- Gripping Systems
- Clamping Systems
- Mounting Elements
- Vacuum Generators
- Valve Technology
- Switches and Monitoring
- Filters and Connections
- Services
- Contact
- Glossary
- Index of Products



## Suitability for Industry Specific Applications

### Applications

- Effortless gripping for small and medium sized workpieces
- Processing of workpieces from all sides with a continuous rotate and pivot function
- Operation with an external vacuum pump, allowing the Multi-Clamp to be used anywhere irrespective of space
- Both product components can either be used in combination or as stand-alone solutions



Multi-Clamp VC-M

### Design

- Various suction plates available to suit different applications
- Clamping lever (1) for quickly changing the Multi-Clamp suction plate
- Free rotation by 360° (2) and continuous swivel up to 90° (3) allow working flexibly from any angle
- Vacuum supply (4) available using either internal compressed air or external vacuum pump
- Can be fastened to the workbench (5) either mechanically or using vacuum

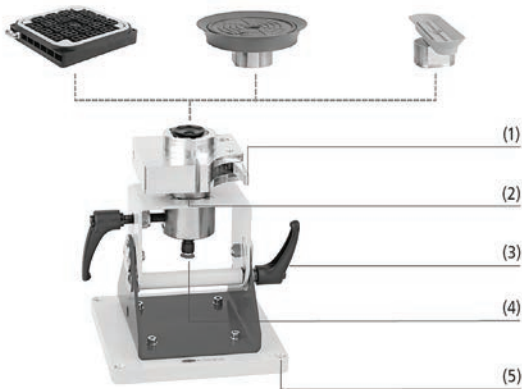

System Design Multi-Clamp VC-M



Multi-Clamp VC-M for manual processing of wooden workpieces

### Our Highlights...

- Version VC-M with integrated vacuum generation (ejector nozzle)
- Multi-Base stageless rotatable by 360° and stageless swivellable by max. 90°
- Multi-Clamp suction plate can be used as single unit

### Your Benefits...

- No additional, expensive vacuum pump required
- Flexible five-axis working without any problems
- Multi-Clamp suction plate can be used as a cost saving stand-alone solution



# Clamping System Matrix-Plate

## Matrix-Plate MPL



Standard dimensions 300 x 200 mm, 400 x 300 mm and 600 x 400 mm

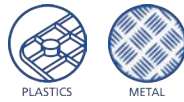

Matrix-Plate MPL

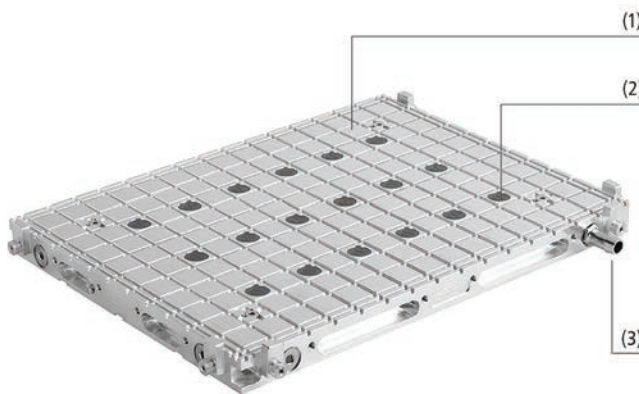

System Design Matrix-Plate MPL

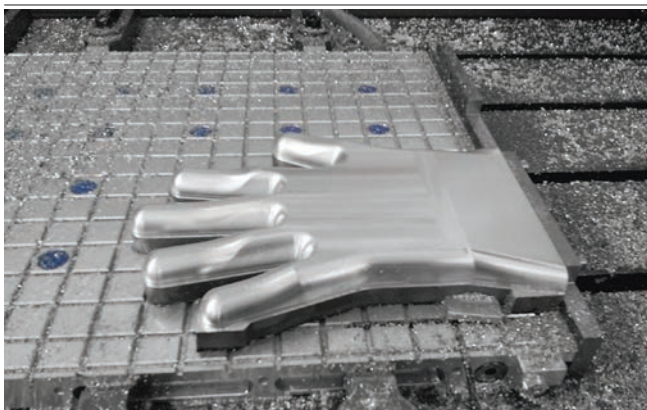

Matrix plate for clamping aluminum parts

### Suitability for Industry Specific Applications

#### Applications

- For workpieces made of aluminum and other nonferromagnetic materials such as CFK or plastic
- Short set-up times due to simple handling
- Modular structure allows flexible adaptation to the workpiece geometry and the type of processing
- Enlargement of clamping area possible by connecting several matrix plates
- Simple mounting on the machine table using clamping claws or a zero point clamping system
- Mechanical stops serve as positioning aids and for taking up additional lateral forces

#### Design

- Main body (1) made of high-strength aluminum with different grid dimensions
- Friction pads (2) for improved lateral force absorption
- Vacuum connection (3)

#### Our Highlights...

- Body made of high strength and precisely manufactured aluminum (height tolerance +/- 0.02 mm)
- Easy to handle
- Mechanical stops laterally mounted
- Modular design

#### Your Benefits...

- Distortion free clamping of large, flat workpieces
- Short set-up times
- Simple positioning of the workpiece and accommodation of additional horizontal forces
- Flexible configuration of machine table



# Innospann Steel-Plate Systems ISST-MPL

Grid measure 75 mm

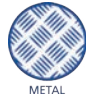

## Suitability for Industry Specific Applications

### Applications

- Steel-Plate for flexible positioning of vacuum blocks is mounted on a Schmalz Matrix-Plate
- Already installed Matrix-Plates can be retrofitted
- Fast retooling when workpieces are changed frequently
- Reduced set-up times and increased holding force
- Vacuum block is hose free and can be positioned without difficulty
- Magnetic pre-fastening of vacuum blocks

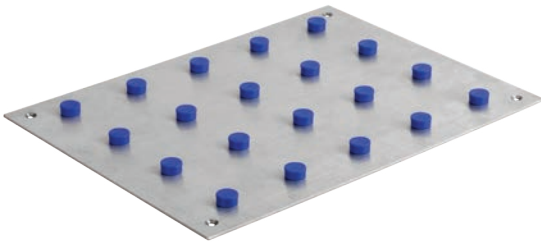

Innospann Steel-Plate Systems ISST-MPL

### Design

- Vacuum block ISBL made of aluminum (1) with magnetic pre-fixing on the steel plate
- Sealing magnet (2)
- Steel-Plate with vacuum openings (3)
- Matrix-Plate with milled grid (4)

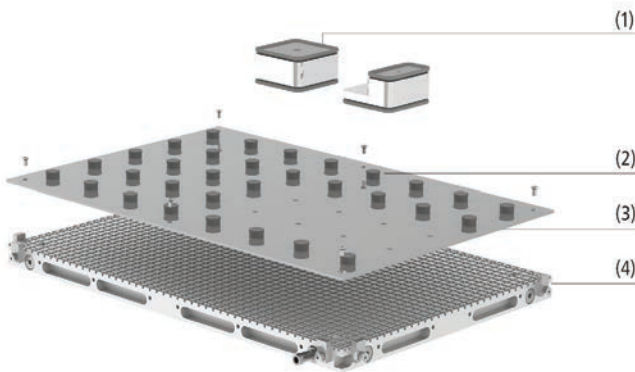

System Design Innospann Steel-Plate Systems ISST-MPL

### Our Highlights...

- Use in conjunction with matrix plate MPL
- Use with vacuum blocks ISBL
- Lasered grid
- All components made of aluminum, stainless steel and process adapted plastics

### Your Benefits...

- Modular system for retrofitting
- Maximum flexibility for breakthroughs and five fold processing
- Orientation guide for the positioning of the vacuum blocks
- Coolant resistant and durable

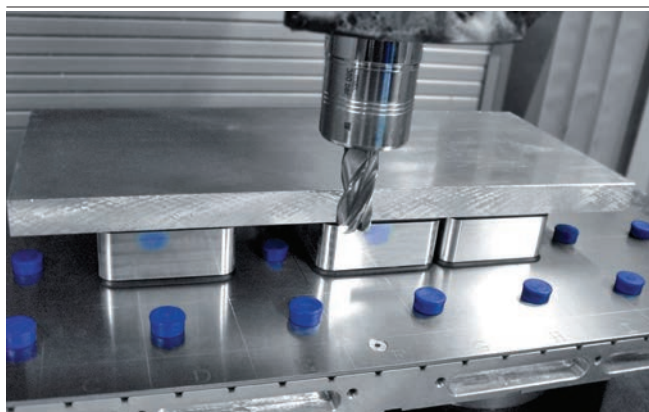

Innospann Steel-Plate ISST-MPL with vacuum blocks ISBL for clamping aluminum

- Schmalz – The Company
- Vacuum Suction Cups
- Special Grippers
- Gripping Systems
- Clamping Systems
- Mounting Elements
- Vacuum Generators
- Valve Technology
- Switches and Monitoring
- Filters and Connections
- Services
- Contact
- Glossary
- Index of Products



# Basic Holding Fixture BHF

Compatible with flat tables and Innospann Steel-Plate



Basic Holding Fixture BHF



System Design Basic Holding Fixture BHF



Uni-Base UB and reference suction cup RSC for clamping carbon fiber-reinforced plastic parts

## Suitability for Industry Specific Applications

### Applications

- For use with CNC laser and milling processes in the woodworking, metal, plastics and fiber composite industry
- Manual processing and finishing of components, for example during sawing, drilling or sanding processes
- For use on flat tables, T nut tables or other types of machine table in combination with Schmalz Steel-Plate
- Flexible manual adjustment of stroke and swivel angle
- High and easily adjustable degree of freedom in all axes

### Design

- Suction cups (1) in various shapes for optimum adaptability
- The angle of inclination is easy to set using the ball joint (2)
- Star grip (3) for precise height adjustment, securely fixed using the clamping lever
- Compressed air connection (4) for the supply of clampable suction elements
- Simple to position and pre-fasten using the magnetic base plate (5)

### Our Highlights...

- Uni-Base adjustable in height and angle
- Can be used with flat tables and Innospann Steel-Plate
- Various suction cups with connection to the Uni-Base

### Your Benefits...

- Maximum spatial freedom to suit any workpiece shape
- Can be used in connection with other clamping equipment from Schmalz
- Ideal adaptation to the workpiece and processes

# Mounting Elements

Schmalz –  
The Company

Vacuum  
Suction Cups

Special  
Grippers

Gripping  
Systems

Clamping  
Systems

**Mounting  
Elements**

Vacuum  
Generators

Valve  
Technology

Switches and  
Monitoring

Filters and  
Connections









Services

Contact

Glossary

Index of  
Products



Selection Aid		Page	
		<b>Overview Connection Possibilities</b>	<b>352</b>
<b>Jointed Mountings</b>			
	<b>Flexolink FLK</b> <ul style="list-style-type: none"> <li>• Connection: M10x1.25 to G1/2"</li> <li>• Deflection: max. 12°</li> </ul>	 <p>Polydirectional joint mounting made from high-quality steel with vulcanize-bonded rubber buffer to adjust the suction cup to uneven surfaces.</p>	<b>354</b>
	<b>Ball Joints KGL</b> <ul style="list-style-type: none"> <li>• Connection: G1/8" to G1/2"</li> <li>• Deflection: max. 15°</li> <li>• Sealed ball-and-socket joint with vacuum tight seal</li> </ul>	 <p>Polydirectional ball joint made from galvanized steel or stainless steel, sealed using O-ring, to adjust the suction cup to uneven surfaces.</p>	<b>357</b>
<b>Spring Plungers</b>			
	<b>Spring Plungers FSTIm</b> <ul style="list-style-type: none"> <li>• Modular suction cup connection</li> <li>• Stroke: 5 to 20 mm</li> <li>• Internal damping spring</li> <li>• With / without anti-rotation guard</li> </ul>	 <p>Spring plunger with internal damping spring and small design for handling sensitive workpieces, particularly in the electronics industry.</p>	<b>360</b>
	<b>Spring Plungers FSTE</b> <ul style="list-style-type: none"> <li>• Connection: M3, M5, G1/8" to G1/2"</li> <li>• Stroke: 5 to 90 mm</li> <li>• Integrated vacuum feed</li> </ul>	 <p>Spring plunger with damping spring for height compensation and careful handling of fragile workpieces.</p>	<b>364</b>

Schmalz – The Company  
 Vacuum Suction Cups  
 Special Grippers  
 Gripping Systems  
 Clamping Systems  
**Mounting Elements**  
 Vacuum Generators  
 Valve Technology  
 Switches and Monitoring  
 Filters and Connections  
 Services  
 Contact  
 Glossary  
 Index of Products

# Overview of Section

## At a Glance

			Page
Schmalz – The Company			
Vacuum Suction Cups		<b>Spring Plungers FSTE-HD</b> <ul style="list-style-type: none"> <li>• Connection: G1/8" to G1/2"</li> <li>• Stroke: 15 to 90 mm</li> <li>• Heavy duty</li> <li>• Integrated vacuum feed</li> </ul>	368
Special Grippers			
Gripping Systems		<b>Spring Plungers FSTE-HDB</b> <ul style="list-style-type: none"> <li>• Connection: G1/8" to G1/2"</li> <li>• Stroke: 15 to 80 mm</li> <li>• Heavy duty, with smooth running anti-rotation guard</li> <li>• Integrated vacuum feed</li> </ul>	372
Clamping Systems		<b>Spring Plungers FSTA</b> <ul style="list-style-type: none"> <li>• Connection: G1/4" and G1/2"</li> <li>• Stroke: 25 to 90 mm</li> <li>• Integrated vacuum feed</li> </ul>	375
Mounting Elements			
Vacuum Generators		<b>Spring Plungers FSTA-HD</b> <ul style="list-style-type: none"> <li>• Connection: G1/4" to G1/2"</li> <li>• Stroke: 25 to 90 mm</li> <li>• Version Heavy duty</li> <li>• Integrated vacuum feed</li> </ul>	378
Valve Technology			
Switches and Monitoring		<b>Spring Plungers FSTI</b> <ul style="list-style-type: none"> <li>• Connection: G1/4" and G3/8"</li> <li>• Stroke: 10 to 50 mm</li> <li>• Internal damping spring</li> <li>• Integrated vacuum feed</li> </ul>	381
Filters and Connections		<b>Spring Plungers FSTF</b> <ul style="list-style-type: none"> <li>• Connection: G1/2"</li> <li>• Stroke: 50 mm</li> <li>• Variable mounting facility</li> <li>• Integrated vacuum feed</li> </ul>	385
Services			
Contact		<b>Suspension Flexible FST-FLEX</b> <ul style="list-style-type: none"> <li>• Connection: G1/2"</li> <li>• Stroke: 25 to 75 mm</li> <li>• Jamming safe by spherical mounting</li> </ul>	388
Glossary			
Index of Products		<b>Suspension rigid FST-STARR</b> <ul style="list-style-type: none"> <li>• Connection: G1/2"</li> <li>• Stroke: 25 to 75 mm</li> <li>• Version Heavy duty</li> </ul>	392

# Overview of Section

At a Glance

## Holder for Suction Cups and Spring Plungers

Page

	<p><b>Adapters for Elbow Connector ANW</b></p> <ul style="list-style-type: none"> <li>• Connection: M3 to G1/2"</li> </ul>		<p>Adapter for elbow connection with side vacuum connection for direct and space-saving installation of suction cups.</p>	<p>396</p>	<p>Schmalz – The Company Vacuum Suction Cups</p>
	<p><b>Bulkhead Connectors SVS-GE</b></p> <ul style="list-style-type: none"> <li>• Connection: G1/8" and G1/4"</li> </ul>		<p>Bulkhead connector for direct and height-adjustable installation of suction cups.</p>	<p>399</p>	<p>Special Grippers Gripping Systems</p>
	<p><b>Holders for Light-Metal Sections HTR-STA</b></p> <ul style="list-style-type: none"> <li>• Mountings for spring plungers FSTE/FSTA from M5 to G1/4"</li> </ul>		<p>Steel sheet holder for direct installation on light alloy sections.</p>	<p>401</p>	<p>Clamping Systems Mounting Elements</p>
	<p><b>Holders for Square Tubes HTR-ST5</b></p> <ul style="list-style-type: none"> <li>• Mountings for spring plungers FSTE/FSTA/FSTI from M5 to G1/2"</li> <li>• Square sections 30 x 30 mm to 60 x 60 mm</li> </ul>		<p>Steel sheet holder for direct installation on square tubes.</p>	<p>403</p>	<p>Vacuum Generators</p>
	<p><b>Universal Holders HTR-UNI</b></p> <ul style="list-style-type: none"> <li>• Mounting thread: M5</li> <li>• Connection: G1/4"</li> </ul>		<p>Holder for adjustable installation of suction cups; height and incline of the suction cup can be adjusted.</p>	<p>406</p>	<p>Valve Technology Switches and Monitoring</p>
<p><b>Sections and Connectors</b></p>					
	<p><b>Mounting Sections MO-PROF</b></p> <ul style="list-style-type: none"> <li>• Cross-sections: 40 x 40 mm and 80 x 40 mm</li> <li>• With 1 or 3 chambers</li> </ul>		<p>High strength aluminum section with accessories for constructing your own load beam with integrated vacuum line.</p>	<p>409</p>	<p>Filters and Connections Services</p>

Contact  
Glossary  
Index of Products



Schmalz – The Company  
 Vacuum Suction Cups  
 Special Grippers  
 Gripping Systems  
 Clamping Systems  
 Mounting Elements  
 Vacuum Generators  
 Valve Technology  
 Switches and Monitoring  
 Filters and Connections  
 Services  
 Contact  
 Glossary  
 Index of Products

**Overview Connection Possibilities**

The following overview shows the various connection possibilities offered by the mounting elements from Schmalz and should help to select the appropriate components for your application. All components of the various product families are grouped together in the overview. Design data and technical data of the mounting elements can be found on the related product pages in this section of the catalog.

**MOUNTING SECTION (also suitable for mounting suction cups)**

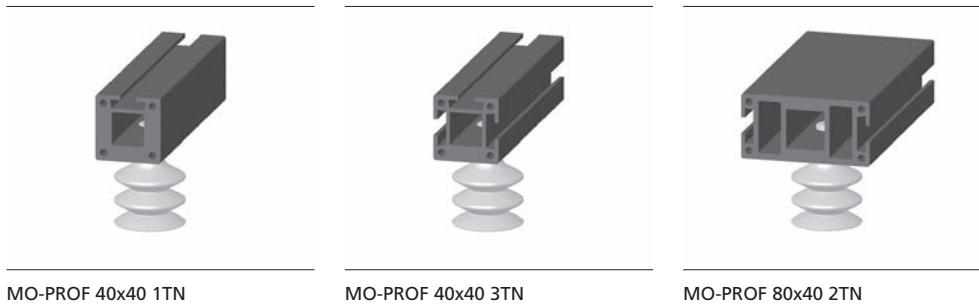

**HOLDERS AND CROSS-BEAM CONNECTORS (for spring-mounting of suction cups)**

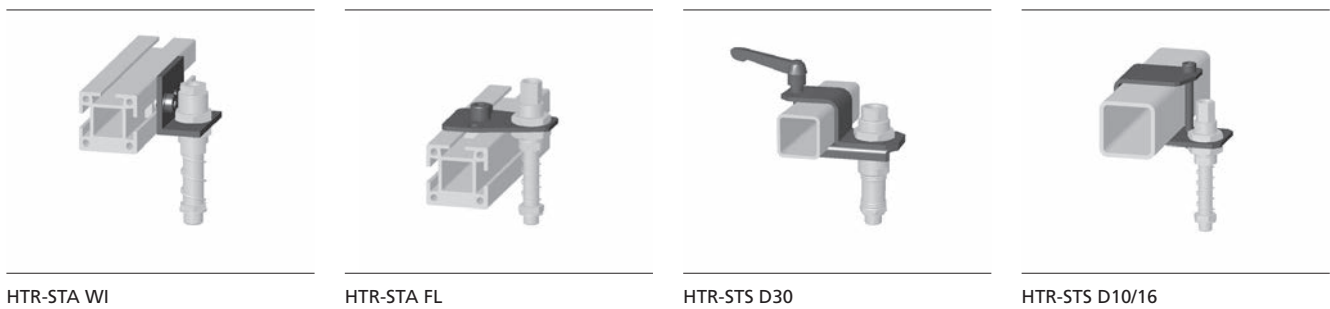

**SPRING PLUNGERS**

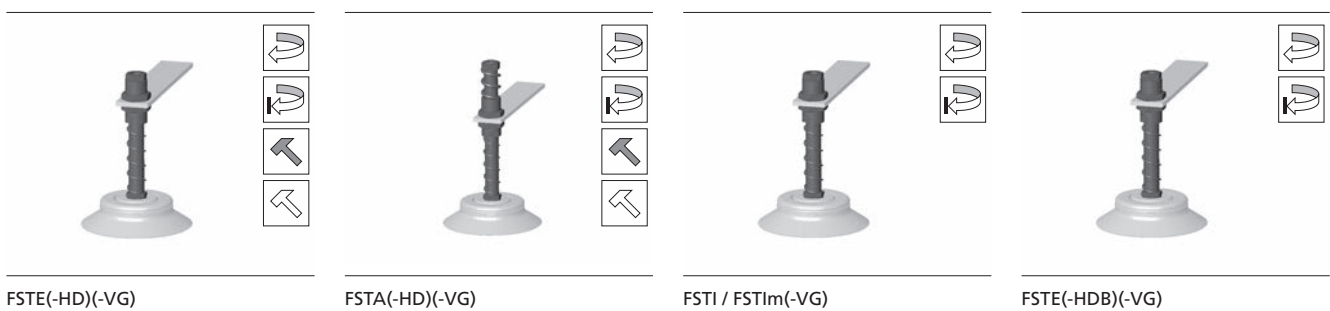

**FLEXIBLE MOUNTINGS FOR USE WITH SPRING PLUNGERS**

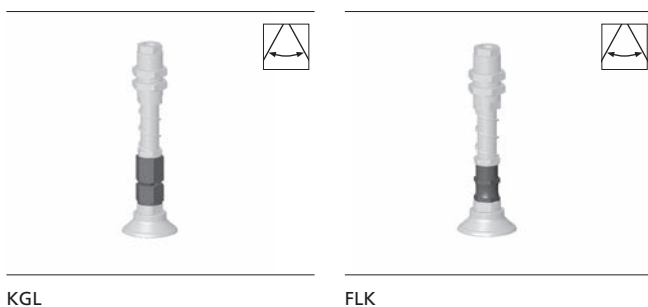

- Fully rotatable
- Available with anti-rotation guard
- Heavy duty (HD) version for short cycle times and rough operating conditions
- For standard applications without swiveling of the loads
- Flexible in all directions



**MOUNTING SECTION (also suitable for mounting of suction cups)**

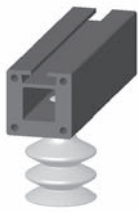

MO-PROF 40x40 1TN

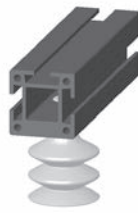

MO-PROF 40x40 3TN

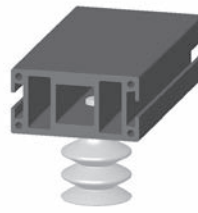

MO-PROF 80x40 2TN

**HOLDERS AND CROSS-BEAM CONNECTORS (for rigid mounting of suction cups)**



HTR-UNI



HTR-UNI STB



HTR-UNI STC



ANW/VRS-AN



SVS-GE

**FLEXIBLE MOUNTINGS FOR USE WITH RIGID SUCTION CUP MOUNTINGS**



KGL



FLK



# Flexolink FLK



Connection thread G1/4" and G1/2"



Flexolink FLK

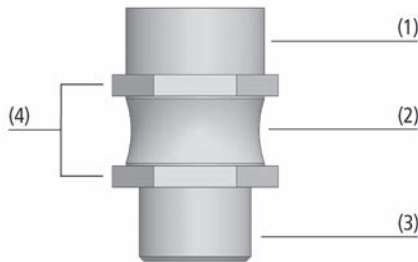

System Design Flexolink FLK

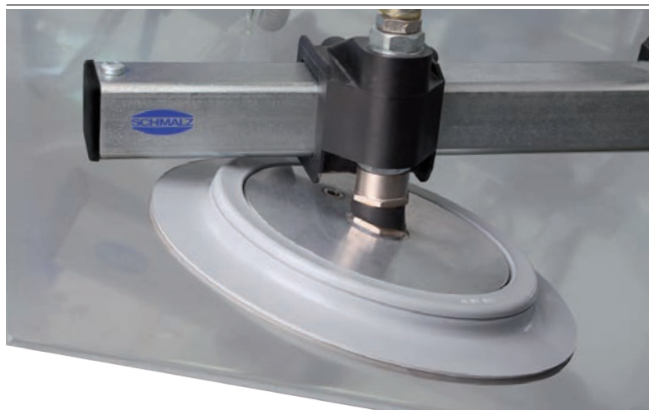

Flexolink FLK for adaptation to sloping metal sheets

## Suitability for Industry Specific Applications

### Applications

- Flexolink for handling of workpieces with sloping surfaces with the aid of large suction cups or suction plates
- Handling of large sheets of materials such as wood or sheet metal, which may sag when lifted; Flexolink prevents the sheet from being pulled off due to one-sided forces
- Can be used together with spring plungers to compensate for differing workpiece heights and uneven surfaces
- Automatic resetting

### Design

- Flexible mounting made of high-quality steel with a rubber buffer (vulcanized into position) as a joint (2)
- Maximum deflection angle limited by a screw-in stop
- Force is transferred via a shaped metal connection within the joint
- Flats on upper and lower halves for damage free installation (4)
- Connection thread for top connection (1) and (3) in various sizes
- Max. deflection: 12°

### Our Highlights...

- Fully flexible mounting of suction cups and suction plates
- Joint made of rubber and metal
- High-strength connection between rubber and metal parts

### Your Benefits...

- Very good adaptation to sloping workpiece surfaces
- Automatic reset function to neutral position
- Reduced wear on suction cups when they are placed on sloping surfaces

- Schmalz – The Company
- Vacuum Suction Cups
- Special Grippers
- Gripping Systems
- Clamping Systems
- Mounting Elements
- Vacuum Generators
- Valve Technology
- Switches and Monitoring
- Filters and Connections
- Services
- Contact
- Glossary
- Index of Products



# Jointed Mountings

## Flexolink FLK



Connection thread G1/4" and G1/2"

### Designation Code Flexolink FLK

<b>FLK</b>	-	<b>G1/2-IG</b>	-	<b>G1/2-AG</b>	-	<b>V</b>
<b>1</b>		<b>2</b>		<b>3</b>		<b>4</b>

#### 1 – Abbreviated designation

Code	Version
FLK	FLK

#### 4 – Product addition

Code	Type
V	Special reinforced Flexolink

#### 2 – Connection 1

Code	Connection
G1/4-AG	G1/4-AG (AG = male (M))
G1/4-IG	G1/4-IG (IG = female (F))
G1/2-AG	G1/2-AG
G1/2-IG	G1/2-IG

#### 3 – Connection 2

Code	Connection
M10x1.25-AG	M10x1.25-AG (AG = male (M))
G1/4-AG	G1/4-AG
G1/2-AG	G1/2-AG

Jointed mounting Flexolink FLK is delivered as a ready-to-connect product.

### Ordering Data Flexolink FLK

Type*	Part no.
FLK G1/4-AG G1/4-AG	10.01.03.00152
FLK G1/4-IG M10x1.25-AG	10.01.03.00206
FLK G1/4-IG G1/4-AG	10.01.03.00178
FLK G1/2-AG G1/2-AG	10.01.03.00153
FLK G1/2-IG G1/2-AG	10.01.03.00175
FLK G1/2-IG G1/2-AG V	10.01.03.00207

\*V = Special reinforced Flexolink for use with suction plates SPU 300 and SPU 400

### Technical Data Flexolink FLK

Type	Vertical load [N]	Bending moment [Nm]	Weight [g]
FLK G1/4-AG G1/4-AG	750	10	30
FLK G1/4-IG M10x1.25-AG	500	8	26
FLK G1/4-IG G1/4-AG	750	10	30
FLK G1/2-AG G1/2-AG	3,000	65	100
FLK G1/2-IG G1/2-AG	3,000	50	100
FLK G1/2-IG G1/2-AG V	4,500	65	190



Schmalz – The Company  
Vacuum Suction Cups  
Special Grippers  
Gripping Systems  
Clamping Systems  
Mounting Elements  
Vacuum Generators  
Valve Technology  
Switches and Monitoring  
Filters and Connections  
Services  
Contact  
Glossary  
Index of Products

# Flexolink FLK

Connection thread G1/4" and G1/2"



## Design Data Flexolink FLK

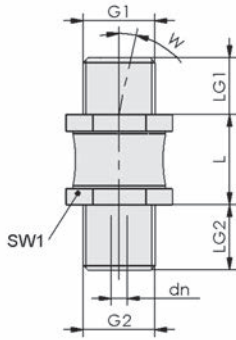

FLK AG-AG

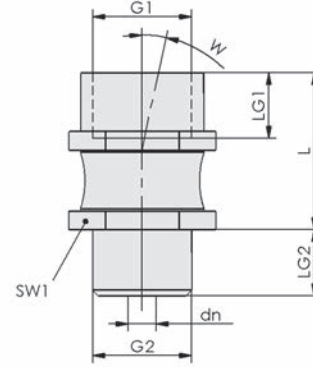

FLK IG-AG

Type	dn [mm]	G1	G2	L [mm]	LG1 [mm]	LG2 [mm]	SW1 [mm]	W [mm]
FLK G1/4-AG G1/4-AG	3.0	G1/4"-M	G1/4"-M	16.5	10.5	12	17	12
FLK G1/4-IG M10x1.25-AG	2.8	G1/4"-F	M10x1.25-M	27.0	10.5	8	17	12
FLK G1/4-IG G1/4-AG	3.0	G1/4"-F	G1/4"-M	27.0	12.0	12	17	12
FLK G1/2-AG G1/2-AG	5.5	G1/2"-M	G1/2"-M	21.0	14.0	14	27	12
FLK G1/2-IG G1/2-AG	6.0	G1/2"-F	G1/2"-M	33.5	14.0	14	27	12
FLK G1/2-IG G1/2-AG V	6.0	G1/2"-F	G1/2"-M	53.0	14.0	14	36	8



- Schmalz - The Company
- Vacuum Suction Cups
- Special Grippers
- Gripping Systems
- Clamping Systems
- Mounting Elements
- Vacuum Generators
- Valve Technology
- Switches and Monitoring
- Filters and Connections
- Services
- Contact
- Glossary
- Index of Products

# Ball Joints KGL

Connection thread from G1/8" to G1/2"



Ball Joints KGL

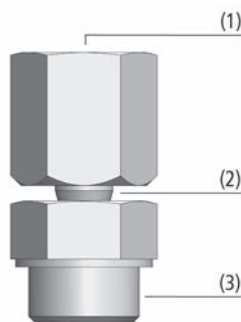

System Design Ball Joints KGL



Mounting example ball joints KGL

## Suitability for Industry Specific Applications

### Applications

- Ball joint for handling of workpieces with sloping surfaces with the aid of large suction cups or suction plates
- Handling of large sheets of materials such as wood or sheet metal which may sag when lifted; flexible mounting with KGL prevents premature pulling-off of the sheet due to one-sided forces
- Can be used together with spring plungers to compensate for differing workpiece heights and uneven surfaces

### Design

- Ball and socket made of galvanized steel (KGL...) or stainless steel (KGL...A2)
- Ball and socket (2) with O-ring seal to prevent vacuum leaks
- Connection thread above (1) and below (3) in various sizes
- Max. deflection: 15°

### Our Highlights...

- Fully flexible mounting of suction cups and suction plates
- Sealed ball-and-socket joint with vacuum tight seal
- Low center of flexure

### Your Benefits...

- Very good adaptation to workpieces with sloping surfaces
- Safe handling
- Minimum wear on the suction cup when it is placed on a sloping surface

# Ball Joints KGL

Connection thread from G1/8" to G1/2"

## Designation Code Ball Joints KGL



### 1 - Abbreviated designation

Code	Version
KGL	KGL

### 2 - Connection 1

Code	Connection
G1/8-IG	G1/8-IG (IG = female (F))
G1/4-IG	G1/4-IG
G1/2-IG	G1/2-IG

### 3 - Connection 2

Code	Connection
G1/8-AG	G1/8-AG (AG = male (M))
G1/4-AG	G1/4-AG
G1/2-AG	G1/2-AG
M10x1.25-AG	M10x1.25-AG

### 4 - Material

Code	Material
-	Galvanised steel
A2	Stainless steel

Ball joint KGL is delivered as a ready-to-connect product.

## Ordering Data Ball Joints KGL

Type	Part no.
KGL G1/8-IG G1/8-AG A2	10.01.03.00109
KGL G1/4-IG G1/4-AG	10.01.03.00110
KGL G1/4-IG M10x1.25-AG	10.01.03.00137
KGL G1/2-IG G1/2-AG	10.01.03.00111

## Technical Data Ball Joints KGL

Type	Vertical load [N]	Weight [g]
KGL G1/8-IG G1/8-AG A2	300	26
KGL G1/4-IG G1/4-AG	1,500	67
KGL G1/4-IG M10x1.25-AG	1,500	67
KGL G1/2-IG G1/2-AG	2,500	116

- Schmalz - The Company
- Vacuum Suction Cups
- Special Grippers
- Gripping Systems
- Clamping Systems
- Mounting Elements
- Vacuum Generators
- Valve Technology
- Switches and Monitoring
- Filters and Connections
- Services
- Contact
- Glossary
- Index of Products

# Ball Joints KGL

Connection thread from G1/8" to G1/2"



## Design Data Ball Joints KGL

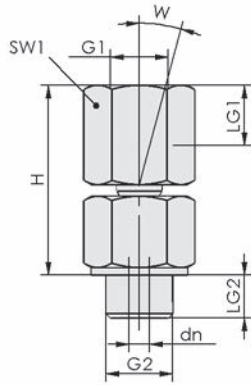

KGL

Type	dn [mm]	G1	G2	H [mm]	LG1 [mm]	LG2 [mm]	SW1 [mm]	W [°]
KGL G1/8-IG G1/8-AG A2	2.0	G1/8"-F	G1/8"-M	27	8.5	7	14	15
KGL G1/4-IG G1/4-AG	3.5	G1/4"-F	G1/4"-M	38	12.0	10	19	15
KGL G1/4-IG M10x1.25-AG	3.5	G1/4"-F	M10x1.25-M	38	12.0	10	19	15
KGL G1/2-IG G1/2-AG	4.0	G1/2"-F	G1/2"-M	40	14.0	12	24	15

- Schmalz – The Company
- Vacuum Suction Cups
- Special Grippers
- Gripping Systems
- Clamping Systems
- Mounting Elements**
- Vacuum Generators
- Valve Technology
- Switches and Monitoring
- Filters and Connections
- Services
- Contact
- Glossary
- Index of Products



# Spring Plungers FSTIm

Stroke from 5 mm to 20 mm



Spring Plungers FSTIm

FSTIm...L

FSTIm...A

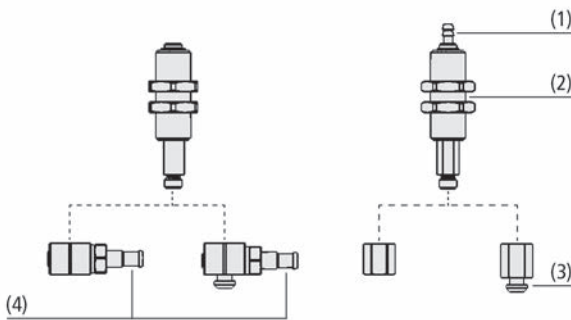

System Design Spring Plungers FSTIm



Spring plungers being used for handling conductor boards

## Suitability for Industry Specific Applications

### Applications

- Spring plunger in small design with internal damping spring for handling of workpieces with differing heights and curvatures
- Handling of very sensitive workpieces (e.g. printed circuit boards) without additional control expenses; ensures gentle placement
- Handling tasks in the electronics industry
- Suitable for cleanroom applications – depending on the application and the loading case, up to cleanroom class ISO1 (according to ISO 14644-1)

### Design

- Modular spring plunger with axial (1) or lateral (4) vacuum connection, version with anti-rotation guard only axial
- Two lock nuts (2) for mounting
- Connection for suction cups of the nipple families N004 and N016 (3) or alternatively via internal thread

### Our Highlights...

- Low spring forces
- Minimum size; optimized in weight
- Internal damping spring
- Ability to connect a second lateral vacuum feed

### Your Benefits...

- Gentle handling process with very sensitive workpieces
- Suitable for confined spaces and high dynamic
- Spring protected against dirt and mechanical damage
- Serial connection of several spring plungers feasible



# Spring Plungers FSTIm

Stroke from 5 mm to 20 mm



## Designation Code Spring Plungers FSTIm

<b>FSTIm</b>	-	<b>M3-IG</b>	-	<b>4/2.5</b>	-	<b>A</b>	-	<b>5</b>	-	<b>VG</b>
<b>1</b>		<b>2</b>		<b>3</b>		<b>4</b>		<b>5</b>		<b>6</b>

### 1 – Abbreviated designation

Code	Version
FSTIm	FSTIm

### 2 – Suction cup connection

Code	Connection
M3-IG	M3-IG (IG= female (F))
M5-IG	M5-IG
N004	N004
N016	N016

### 3 – Hose diameter

Code	Dimensions in mm
4/2.5	4/2.5
6/4	6/4

### 4 – Vacuum connection

Code	Connection
A	Axial
L	Lateral

### 5 – Plunger stroke

Code	Plunger stroke in mm
5...20	5 to 20

### 6 – Product addition

Code	Type
VG	With anti-rotation guard

Spring Plunger FSTIm is delivered assembled.

Available accessories: vacuum hose, hose sleeve



## Ordering Data Spring Plungers FSTIm

Type*					Plunger stroke in mm:		
					5	10	20
FSTIm	M3-IG	-	A	-	10.01.02.01333	-	-
FSTIm	M3-IG	-	A	VG	10.01.02.01259	-	-
FSTIm	M3-IG	-	L	-	10.01.02.01334	-	-
FSTIm	-	N004	A	-	10.01.02.01335	10.01.02.01339	-
FSTIm	-	N004	A	VG	10.01.02.01275	10.01.02.01282	-
FSTIm	-	N004	L	-	10.01.02.01336	10.01.02.01340	-
FSTIm	M5-IG	-	A	-	-	10.01.02.01337	10.01.02.01344
FSTIm	M5-IG	-	A	VG	-	10.01.02.01247	10.01.02.01293
FSTIm	M5-IG	-	L	-	-	10.01.02.01338	10.01.02.01343
FSTIm	-	N016	A	-	-	-	10.01.02.01342
FSTIm	-	N016	A	VG	-	-	10.01.02.01285
FSTIm	-	N016	L	-	-	-	10.01.02.01341

\*Recommendation: To raise the lifetime in continuous operation, prevent the maximal slide stroke

# Spring Plungers FSTIm

Stroke from 5 mm to 20 mm



## Ordering Data Accessories Spring Plungers FSTIm

Type	Vacuum hose		Hose sleeve	
FSTIm M3-IG - A 5	10.07.09.00142		-	
FSTIm M3-IG - L 5	10.07.09.00142		10.08.03.00312	
FSTIm - N004 A 5	10.07.09.00142		-	
FSTIm - N004 L 5	10.07.09.00142		10.08.03.00312	
FSTIm M5-IG - A 10	10.07.09.00141		-	
FSTIm M5-IG - L 10	10.07.09.00141		10.08.03.00311	
FSTIm - N004 A 10	10.07.09.00141		-	
FSTIm - N004 L 10	10.07.09.00141		10.08.03.00311	
FSTIm M5-IG - A 20	10.07.09.00141		-	
FSTIm M5-IG - L 20	10.07.09.00141		10.08.03.00311	
FSTIm - N016 A 20	10.07.09.00141		-	
FSTIm - N016 L 20	10.07.09.00141		10.08.03.00311	



## Technical Data Spring Plungers FSTIm

Type	Spring rate [N/mm]	Spring pretension [N/mm]	Spring force, center [N]*	Vertical load [N]**	Horizontal load [N]***	Weight [g]	Operating temperature [°C]
FSTIm M3-IG 4/2.5 A 5	0.055	0.5	0.64	15	10.0	14	0 ... 80
FSTIm M3-IG 4/2.5 A 5 VG	0.055	0.5	0.64	15	10.0	14	0 ... 80
FSTIm M3-IG 4/2.5 L 5	0.055	0.5	0.64	15	10.0	16	0 ... 80
FSTIm M5-IG 6/4 A 10	0.050	0.5	0.75	15	10.0	16	0 ... 80
FSTIm M5-IG 6/4 A 10 VG	0.050	0.5	0.75	15	10.0	16	0 ... 80
FSTIm M5-IG 6/4 A 20	0.052	0.5	1.02	15	10.0	21	0 ... 80
FSTIm M5-IG 6/4 A 20 VG	0.052	0.5	1.02	15	10.0	21	0 ... 80
FSTIm M5-IG 6/4 L 10	0.050	0.5	0.75	15	10.0	18	0 ... 80
FSTIm M5-IG 6/4 L 20	0.052	0.5	1.02	15	10.0	23	0 ... 80
FSTIm N004 4/2.5 A 5	0.055	0.5	0.64	15	10.0	12	0 ... 80
FSTIm N004 4/2.5 A 5 VG	0.055	0.5	0.64	15	10.0	12	0 ... 80
FSTIm N004 4/2.5 L 5	0.055	0.5	0.64	15	10.0	16	0 ... 80
FSTIm N004 6/4 A 10	0.050	0.5	0.75	15	10.0	15	0 ... 80
FSTIm N004 6/4 A 10 VG	0.050	0.5	0.75	15	10.0	15	0 ... 80
FSTIm N004 6/4 L 10	0.050	0.5	0.75	15	10.0	18	0 ... 80
FSTIm N016 6/4 A 20	0.052	0.5	1.02	15	10.0	20	0 ... 80
FSTIm N016 6/4 A 20 VG	0.052	0.5	1.02	15	10.0	19	0 ... 80
FSTIm N016 6/4 L 20	0.052	0.5	1.02	15	10.0	23	0 ... 80

\*Referred to 50 % of operating stroke

\*\*Maximum static loading

\*\*\*The specification of the horizontal load refers to the lower edge of the plunger with extended spring. It is a maximum static stress and it impairs the spring compression and extension in horizontal position.



# Spring Plungers FSTIm

Stroke from 5 mm to 20 mm



## Design Data Spring Plungers FSTIm

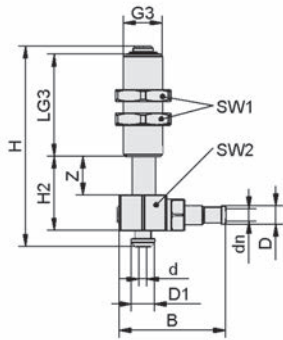

FSTIm N004, N016 L

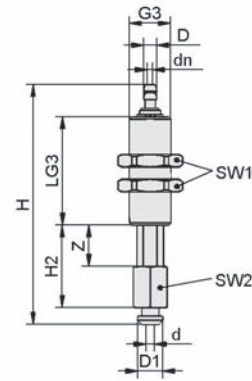

FSTIm N004, N016 A

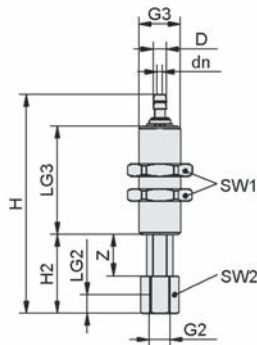

FSTIm M3-IG, M5-IG A

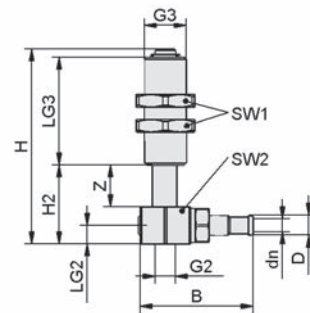

FSTIm M3-IG, M5-IG L

Type	B [mm]	d [mm]	dn [mm]	D [mm]	D1 [mm]	G2	G3	H [mm]	H2 [mm]	LG2 [mm]	LG3 [mm]	SW1 [mm]	SW2 [mm]	Z (Stroke) [mm]
FSTIm M3-IG 4/2.5 A 5	-	-	1.3	2.5	-	M3-F	M10x1-M	40.7	14.0	5	19	14	8	5
FSTIm M3-IG 4/2.5 A 5 VG	-	-	1.3	2.5	-	M3-F	M10x1-M	40.7	14.0	5	19	14	8	5
FSTIm M3-IG 4/2.5 L 5	21.5	-	1.8	2.5	-	M3-F	M10x1-M	35.0	14.0	5	19	14	13	5
FSTIm N004 4/2.5 A 5	-	2.0	1.3	3.2	6.0	-	M10x1-M	45.7	15.0	-	19	14	8	5
FSTIm N004 4/2.5 A 5 VG	-	2.0	1.3	2.5	6.0	-	M10x1-M	45.7	15.0	-	19	14	8	5
FSTIm N004 4/2.5 L 5	21.5	2.0	1.8	2.5	6.0	-	M10x1-M	39.0	14.0	-	19	14	13	5
FSTIm M5-IG 6/4 A 10	-	-	2.0	4.0	-	M5-F	M10x1-M	54.7	19.0	5	26	14	8	10
FSTIm M5-IG 6/4 A 10 VG	-	-	2.0	4.0	-	M5-F	M10x1-M	54.7	19.0	5	26	14	8	10
FSTIm M5-IG 6/4 L 10	23.2	-	2.5	4.0	-	M5-F	M10x1-M	47.0	19.0	5	26	14	13	10
FSTIm N004 6/4 A 10	-	2.0	2.0	4.0	6.0	-	M10x1-M	59.7	20.0	-	26	14	8	10
FSTIm N004 6/4 A 10 VG	-	2.0	2.0	4.0	6.0	-	M10x1-M	59.7	20.0	-	26	14	8	10
FSTIm N004 6/4 L 10	23.2	2.0	2.5	4.0	6.0	-	M10x1-M	51.0	19.0	-	26	14	13	10
FSTIm M5-IG 6/4 A 20	-	-	2.0	4.0	-	M5-F	M10x1-M	79.7	29.0	5	41	14	8	20
FSTIm M5-IG 6/4 A 20 VG	-	-	2.0	4.0	-	M5-F	M10x1-M	79.7	29.0	5	41	14	8	20
FSTIm M5-IG 6/4 L 20	23.2	-	2.5	4.0	-	M5-F	M10x1-M	72.0	29.0	5	41	14	13	20
FSTIm N016 6/4 A 20	-	2.5	2.0	4.0	6.5	-	M10x1-M	86.7	30.0	-	41	14	8	20
FSTIm N016 6/4 A 20 VG	-	2.5	2.0	4.0	6.5	-	M10x1-M	86.7	30.0	-	41	14	8	20
FSTIm N016 6/4 L 20	23.2	2.5	2.5	4.0	6.5	-	M10x1-M	78.0	29.0	-	41	14	13	20

Schmalz – The Company  
 Vacuum Suction Cups  
 Special Grippers  
 Gripping Systems  
 Clamping Systems  
 Mounting Elements  
 Vacuum Generators  
 Valve Technology  
 Switches and Monitoring  
 Filters and Connections  
 Services  
 Contact  
 Glossary  
 Index of Products

# Spring Plungers FSTE

Stroke from 5 mm to 90 mm



## Suitability for Industry Specific Applications

### Applications

- Spring plunger for handling of workpieces with differing heights, such as curved metal sheets, etc.
- Handling of sensitive workpieces (such as sheets of glass) without additional control functions to prevent damage, since the plunger ensures soft placement



Spring Plungers FSTE

### Design

- Spring plunger consisting of a high strength rod made of galvanized steel, guide sleeve (2) and lower damping springs (4)
- Plunger rod with integrated vacuum feed, always female connection thread (1)
- Always female connection thread for suction cups (5) up to size M5, otherwise male thread
- Two lock nuts (3) for attachment

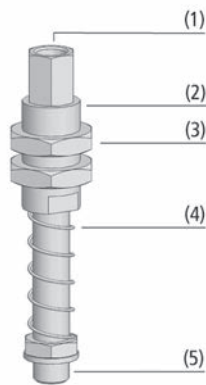

System Design Spring Plungers FSTE

### Our Highlights...

- Spring plunger with lower damping spring
- Wide range of connection threads and stroke lengths
- Available with anti-rotation guard

### Your Benefits...

- Soft placement of the suction cup on sensitive workpieces; good compensation for varying workpiece heights
- For a wide range of applications; available for all suction cups of the standard range
- Suitable for use with oval suction cups



Mounting example Spring Plungers FSTE

- Schmalz – The Company
- Vacuum Suction Cups
- Special Grippers
- Gripping Systems
- Clamping Systems
- Mounting Elements
- Vacuum Generators
- Valve Technology
- Switches and Monitoring
- Filters and Connections
- Services
- Contact
- Glossary
- Index of Products

Stroke from 5 mm to 90 mm



## Designation Code Spring Plungers FSTE

<b>FSTE</b>	-	<b>M3-IG</b>	-	<b>5</b>	-	<b>VG</b>
1		2		3		4

## 1 – Abbreviated designation

Code	Version
FSTE	FSTE

## 4 – Product addition

Code	Type
VG	With anti-rotation guard

## 2 – Suction cup connection

Code	Connection
M3-IG	M3-IG (IG = female (F))
M5-IG	M5-IG
G1/8-AG	G1/8-AG (AG = male (M))
G1/4-AG	G1/4-AG
G1/2-AG	G1/2-AG

## 3 – Plunger stroke

Code	Plunger stroke in mm
5...90	5 to 90

Spring plunger FSTE is delivered as a ready-to-connect product.



## Ordering Data Spring Plungers FSTE

Type*		Plunger stroke in mm: **							
		5	10	15	20	25	50	75	90
FSTE	M3-IG -	10.01.02.00613	-	-	-	-	-	-	-
FSTE	M3-IG VG	10.01.02.00614	-	-	-	-	-	-	-
FSTE	M5-IG -	10.01.02.00607	10.01.02.00608	-	10.01.02.00609	-	-	-	-
FSTE	M5-IG VG	10.01.02.00610	10.01.02.00611	-	10.01.02.00612	-	-	-	-
FSTE	G1/8-AG -	-	-	10.01.02.00602	-	10.01.02.00603	10.01.02.00604	-	-
FSTE	G1/8-AG VG	-	-	10.01.02.00605	-	-	10.01.02.00606	-	-
FSTE	G1/4-AG -	-	-	-	-	10.01.02.00567	10.01.02.00568	10.01.02.00569	-
FSTE	G1/4-AG VG	-	-	-	-	10.01.02.00570	-	10.01.02.00571	-
FSTE	G1/2-AG -	-	-	-	-	10.01.02.00574	-	10.01.02.00575	10.01.02.00576

\*VG = Version with anti-rotation guard for repeatably accurate positioning of suction cups

\*\*Recommendation: To raise the lifetime in continuous operation, prevent the maximal slide stroke



## Technical Data Spring Plungers FSTE

Type	Spring rate [N/mm]	Spring pretension [N/mm]	Spring force, center [N]*	Vertical load [N]**	Horizontal load [N]**	Weight [g]	Operating temperature [°C]
FSTE M3-IG 5	0.596	1.49	2.98	550	47	9	0 ... 80
FSTE M3-IG 5 VG	0.596	1.49	2.98	550	47	9	0 ... 80
FSTE M5-IG 5	0.508	3.30	4.57	1,500	132	16	0 ... 80
FSTE M5-IG 5 VG	0.508	3.30	4.57	1,500	132	16	0 ... 80
FSTE M5-IG 10	0.323	2.75	4.37	1,500	97	19	0 ... 80
FSTE M5-IG 10 VG	0.323	2.75	4.37	1,500	97	19	0 ... 80
FSTE M5-IG 20	0.209	1.78	3.87	1,500	63	25	0 ... 80
FSTE M5-IG 20 VG	0.209	1.78	3.87	1,500	63	25	0 ... 80
FSTE G1/8-AG 15	0.221	3.53	5.19	3,700	385	80	0 ... 80
FSTE G1/8-AG 15 VG	0.221	3.53	5.19	3,700	385	80	0 ... 80
FSTE G1/8-AG 25	0.143	3.57	5.36	3,700	283	90	0 ... 80
FSTE G1/8-AG 50	0.097	2.92	5.34	3,700	173	110	0 ... 80
FSTE G1/8-AG 50 VG	0.097	2.92	5.34	3,700	173	110	0 ... 80
FSTE G1/4-AG 25	0.711	6.47	15.36	2,400	747	145	0 ... 80
FSTE G1/4-AG 25 VG	0.711	6.47	15.36	2,400	747	144	0 ... 80
FSTE G1/4-AG 50	0.452	1.40	12.70	2,400	466	175	0 ... 80



# Spring Plungers FSTE

Stroke from 5 mm to 90 mm



## Technical Data Spring Plungers FSTE

Type	Spring rate [N/mm]	Spring pretension [N/mm]	Spring force, center [N]*	Vertical load [N]**	Horizontal load [N]***	Weight [g]	Operating temperature [°C]
FSTE G1/4-AG 75	0.262	5.38	15.20	2,400	340	190	0 ... 80
FSTE G1/4-AG 75 VG	0.262	5.38	15.20	2,400	340	202	0 ... 80
FSTE G1/2-AG 25	3.829	25.64	73.50	4,900	1,870	400	0 ... 80
FSTE G1/2-AG 75	1.072	37.21	77.41	4,900	800	530	0 ... 80
FSTE G1/2-AG 90	1.072	24.38	75.30	4,900	730	544	0 ... 80

\*Referred to 50 % of operating stroke

\*\*Maximum static loading

\*\*\*The specification of the horizontal load refers to the lower edge of the plunger with extended spring. It is a maximum static stress and it impairs the spring compression and extension in horizontal position.



## Design Data Spring Plungers FSTE

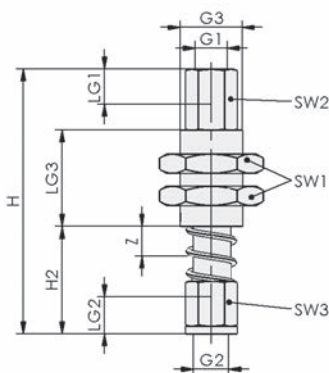

FSTE M3 - M5 (VG)

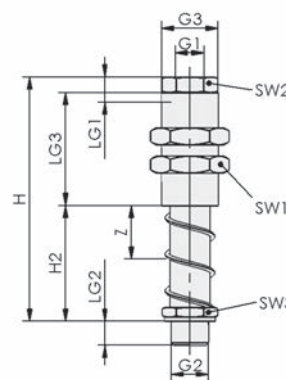

FSTE G1/8 - G1/2 (VG)

Type	G1	G2	G3	H [mm]	H2 [mm]	LG1 [mm]	LG2 [mm]	LG3 [mm]	SW1 [mm]	SW2 [mm]	SW3 [mm]	Z (Stroke) [mm]
FSTE M3-IG 5	M3-F	M3-F	M6x0.75-M	33.5	15.0	3.8	6.0	10	10	5	7	5
FSTE M3-IG 5 VG	M3-F	M3-F	M6x0.75-M	33.5	15.0	3.8	6.0	10	10	5	7	5
FSTE M5-IG 5	M5-F	M5-F	G1/8"-M	41.2	17.0	5.5	6.2	15	14	7	7	5
FSTE M5-IG 5 VG	M5-F	M5-F	G1/8"-M	41.2	17.0	5.5	6.2	12	14	7	7	5
FSTE M5-IG 10	M5-F	M5-F	G1/8"-M	47.2	23.0	5.5	6.2	15	14	7	7	10
FSTE M5-IG 10 VG	M5-F	M5-F	G1/8"-M	47.2	23.0	5.5	6.2	12	14	7	7	10
FSTE M5-IG 20	M5-F	M5-F	G1/8"-M	59.2	35.0	5.5	6.2	15	14	7	7	20
FSTE M5-IG 20 VG	M5-F	M5-F	G1/8"-M	59.2	35.0	5.5	6.2	15	14	7	7	20
FSTE G1/8-AG 15	G1/8"-F	G1/8"-M	M16x1-M	73.5	29.5	8.0	6.5	30	22	12	14	15
FSTE G1/8-AG 15 VG	G1/8"-F	G1/8"-M	M16x1-M	73.5	28.5	8.0	6.5	30	22	12	14	15
FSTE G1/8-AG 25	G1/8"-F	G1/8"-M	M16x1-M	86.5	42.5	8.0	6.5	30	22	12	14	25
FSTE G1/8-AG 50	G1/8"-F	G1/8"-M	M16x1-M	117.5	73.5	8.0	6.5	30	22	12	14	50
FSTE G1/8-AG 50 VG	G1/8"-F	G1/8"-M	M16x1-M	117.5	72.5	8.0	6.5	30	22	12	14	50
FSTE G1/4-AG 25	G1/8"-F	G1/4"-M	M20x1.5-M	86.0	40.5	13.0	8.5	40	24	17	17	25



# Spring Plungers FSTE

Stroke from 5 mm to 90 mm



## Design Data Spring Plungers FSTE

Type	G1	G2	G3	H [mm]	H2 [mm]	LG1 [mm]	LG2 [mm]	LG3 [mm]	SW1 [mm]	SW2 [mm]	SW3 [mm]	Z (Stroke) [mm]
FSTE G1/4-AG 25 VG	G1/8"-F	G1/4"-M	M20x1.5-M	86.0	40.5	13.0	8.5	40	24	17	17	25
FSTE G1/4-AG 50	G1/8"-F	G1/4"-M	M20x1.5-M	115.5	70.0	13.0	8.5	40	24	17	17	50
FSTE G1/4-AG 75	G1/8"-F	G1/4"-M	M20x1.5-M	145.0	99.5	13.0	8.5	40	24	17	17	75
FSTE G1/4-AG 75 VG	G1/8"-F	G1/4"-M	M20x1.5-M	145.0	99.5	13.0	8.5	40	24	17	17	75
FSTE G1/2-AG 25	G3/8"-F	G1/2"-M	M30x1.5-M	105.5	42.5	13.0	10.5	55	36	24	24	25
FSTE G1/2-AG 75	G3/8"-F	G1/2"-M	M30x1.5-M	176.5	113.5	13.0	10.5	55	36	24	24	75
FSTE G1/2-AG 90	G3/8"-F	G1/2"-M	M30x1.5-M	188.5	125.5	13.0	10.5	55	36	24	24	90

Schmalz –  
The CompanyVacuum  
Suction CupsSpecial  
GrippersGripping  
SystemsClamping  
SystemsMounting  
ElementsVacuum  
GeneratorsValve  
TechnologySwitches and  
MonitoringFilters and  
Connections

Services

Contact

Glossary

Index of  
Products

# Spring Plungers FSTE-HD

Stroke from 15 mm to 90 mm



Spring Plungers FSTE-HD

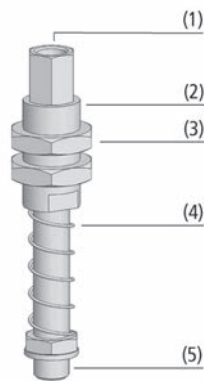

System Design Spring Plungers FSTE-HD



Mounting example Spring Plungers FSTE-HD

## Suitability for Industry Specific Applications

### Applications

- Spring plunger with special sliding bearings and one damping spring for handling of workpieces with differing heights, such as curved metal sheets, etc.
- Handling of sensitive workpieces (such as sheets of glass) without additional control functions to prevent damage, since the plunger ensures soft placement
- For use under rough operating conditions
- For handling tasks with very dynamic motion and short cycle times

### Design

- Spring plunger consisting of high strength stainless steel rod, brass sleeve with integrated bearing (2) and damping spring (4)
- Plunger rod with integrated vacuum feed, always female connection thread (1)
- Anti-rotation guard due to flat side on the rod and a correspondingly shaped guide sleeve
- Always male connection thread for suction cup (5)
- Two lock nuts (3) for attachment

### Our Highlights...

- Spring plunger with high quality sliding bearings and one or two damping springs
- Available with anti-rotation guard
- Wide range of connection threads and stroke lengths

### Your Benefits...

- Maintenance free, with extremely long operating lifetime; suitable for short cycle times
- Guarantees soft placement on sensitive workpieces; absorbs shocks and vibration
- Available for a wide range of applications and for all standard suction cups

- Schmalz – The Company
- Vacuum Suction Cups
- Special Grippers
- Gripping Systems
- Clamping Systems
- Mounting Elements
- Vacuum Generators
- Valve Technology
- Switches and Monitoring
- Filters and Connections
- Services
- Contact
- Glossary
- Index of Products





# Spring Plungers FSTE-HD

Stroke from 15 mm to 90 mm



## Designation Code Spring Plungers FSTE-HD

<b>FSTE</b>	-	<b>HD</b>	-	<b>G1/8-AG</b>	-	<b>15</b>	-	<b>VG</b>
1		2		3		4		5

### 1 – Abbreviated designation

Code	Version
FSTE	FSTE

### 2 – Variant

Code	Type
HD	Heavy duty

### 3 – Suction cup connection

Code	Connection
G1/8-AG	G1/8-AG (AG = male (M))
G1/4-AG	G1/4-AG
G3/8-AG	G3/8-AG
G1/2-AG	G1/2-AG

### 4 – Plunger stroke

Code	Plunger stroke in mm
15...90	15 to 90

### 5 – Product addition

Code	Type
VG	With anti-rotation guard

Spring plunger FSTE-HD is delivered as a ready-to-connect product.



## Ordering Data Spring Plungers FSTE-HD

Type*			Plunger stroke in mm: **				
			15	25	50	75	90
FSTE-HD	G1/8-AG	-	10.01.02.00756	10.01.02.00757	10.01.02.00758	-	-
FSTE-HD	G1/8-AG	VG	10.01.02.00872	10.01.02.00873	10.01.02.00874	-	-
FSTE-HD	G1/4-AG	-	-	10.01.02.00763	10.01.02.00764	10.01.02.00765	-
FSTE-HD	G1/4-AG	VG	-	10.01.02.00875	10.01.02.00876	10.01.02.00877	10.01.02.01056
FSTE-HD	G3/8-AG	-	-	10.01.02.00811	-	10.01.02.00812	10.01.02.00813
FSTE-HD	G3/8-AG	VG	-	10.01.02.00878	-	10.01.02.00879	10.01.02.00880
FSTE-HD	G1/2-AG	-	-	10.01.02.00770	-	10.01.02.00771	10.01.02.00772
FSTE-HD	G1/2-AG	VG	-	10.01.02.00881	-	10.01.02.00882	10.01.02.00883

\*VG = Version with anti-rotation guard for repeatably accurate positioning of suction cups

\*\*Recommendation: To raise the lifetime in continuous operation, prevent the maximal slide stroke



## Technical Data Spring Plungers FSTE-HD

Type	Spring rate [N/mm]	Spring pretension [N/mm]	Spring force, center [N]*	Vertical load [N]**	Horizontal load [N]***	Weight [g]	Operating temperature [°C]
FSTE-HD G1/8-AG 15	0.221	3.53	5.19	3,700	385	80	0 ... 80
FSTE-HD G1/8-AG 15 VG	0.221	3.53	5.19	3,700	385	80	0 ... 80
FSTE-HD G1/8-AG 25	0.143	3.57	5.36	3,700	283	90	0 ... 80
FSTE-HD G1/8-AG 25 VG	0.143	3.57	5.36	3,700	283	90	0 ... 80
FSTE-HD G1/8-AG 50	0.097	2.92	5.34	3,700	173	110	0 ... 80
FSTE-HD G1/8-AG 50 VG	0.097	2.92	5.34	3,700	173	110	0 ... 80
FSTE-HD G1/4-AG 25	0.711	6.47	15.36	2,400	747	145	0 ... 80
FSTE-HD G1/4-AG 25 VG	0.711	6.47	15.36	2,400	747	145	0 ... 80
FSTE-HD G1/4-AG 50	0.452	1.40	12.70	2,400	466	175	0 ... 80
FSTE-HD G1/4-AG 50 VG	0.452	1.40	12.70	2,400	466	175	0 ... 80
FSTE-HD G1/4-AG 75	0.262	5.38	15.20	2,400	340	190	0 ... 80
FSTE-HD G1/4-AG 75 VG	0.262	5.38	15.20	2,400	340	190	0 ... 80
FSTE-HD G1/4-AG 90 VG	0.262	1.49	13.28	1,500	300	210	0 ... 80
FSTE-HD G3/8-AG 25	3.829	25.64	73.50	4,800	1,870	400	0 ... 80
FSTE-HD G3/8-AG 25 VG	3.829	25.64	73.50	4,800	1,870	400	0 ... 80
FSTE-HD G3/8-AG 75	1.072	37.21	77.41	4,800	800	530	0 ... 80



# Spring Plungers FSTE-HD

Stroke from 15 mm to 90 mm

Schmalz – The Company  
Vacuum Suction Cups  
Special Grippers  
Gripping Systems  
Clamping Systems  
Mounting Elements  
Vacuum Generators  
Valve Technology  
Switches and Monitoring  
Filters and Connections  
Services  
Contact  
Glossary  
Index of Products



## Technical Data Spring Plungers FSTE-HD

Type	Spring rate [N/mm]	Spring pretension [N/mm]	Spring force, center [N]*	Vertical load [N]**	Horizontal load [N]***	Weight [g]	Operating temperature [°C]
FSTE-HD G3/8-AG 75 VG	1.072	37.21	77.41	4,800	800	530	0 ... 80
FSTE-HD G3/8-AG 90	1.072	24.38	75.30	4,800	730	545	0 ... 80
FSTE-HD G3/8-AG 90 VG	1.072	24.38	75.30	4,800	730	545	0 ... 80
FSTE-HD G1/2-AG 25	3.829	25.64	73.50	4,900	1,870	400	0 ... 80
FSTE-HD G1/2-AG 25 VG	3.829	25.64	73.50	4,900	1,870	400	0 ... 80
FSTE-HD G1/2-AG 75	1.072	37.21	77.41	4,900	800	530	0 ... 80
FSTE-HD G1/2-AG 75 VG	1.072	37.21	77.41	4,900	800	530	0 ... 80
FSTE-HD G1/2-AG 90	1.072	24.38	75.30	4,900	730	544	0 ... 80
FSTE-HD G1/2-AG 90 VG	1.072	24.38	75.30	4,900	730	545	0 ... 80

\*Referred to 50 % of operating stroke

\*\*Maximum static loading

\*\*\*The specification of the horizontal load refers to the lower edge of the plunger with extended spring. It is a maximum static stress and it impairs the spring compression and extension in horizontal position.



## Design Data Spring Plungers FSTE-HD

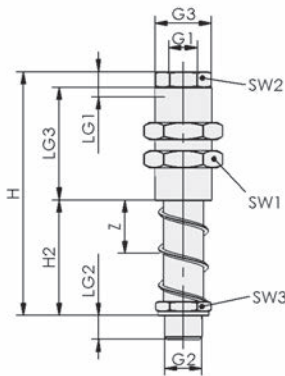

FSTE-HD

Type	G1	G2	G3	H [mm]	H2 [mm]	LG1 [mm]	LG2 [mm]	LG3 [mm]	SW1 [mm]	SW2 [mm]	SW3 [mm]	Z (Stroke) [mm]
FSTE-HD G1/8-AG 15	G1/8"-F	G1/8"-M	M16x1-M	72.5	28.5	8	7.5	30	22	12	14	15
FSTE-HD G1/8-AG 15 VG	G1/8"-F	G1/8"-M	M16x1-M	72.5	28.5	8	7.5	30	22	12	14	15
FSTE-HD G1/8-AG 25	G1/8"-F	G1/8"-M	M16x1-M	85.5	41.5	8	7.5	30	22	12	14	25
FSTE-HD G1/8-AG 25 VG	G1/8"-F	G1/8"-M	M16x1-M	85.5	41.5	8	7.5	30	22	12	14	25
FSTE-HD G1/8-AG 50	G1/8"-F	G1/8"-M	M16x1-M	116.5	72.5	8	7.5	30	22	12	14	50
FSTE-HD G1/8-AG 50 VG	G1/8"-F	G1/8"-M	M16x1-M	116.5	72.5	8	7.5	30	22	12	14	50
FSTE-HD G1/4-AG 25	G1/8"-F	G1/4"-M	M20x1.5-M	86.0	40.5	13	8.5	40	24	17	17	25
FSTE-HD G1/4-AG 25 VG	G1/8"-F	G1/4"-M	M20x1.5-M	86.0	40.5	13	8.5	40	24	17	17	25
FSTE-HD G1/4-AG 50	G1/8"-F	G1/4"-M	M20x1.5-M	115.5	70.0	13	8.5	40	24	17	17	50
FSTE-HD G1/4-AG 50 VG	G1/8"-F	G1/4"-M	M20x1.5-M	115.5	70.0	13	8.5	40	24	17	17	50
FSTE-HD G1/4-AG 75	G1/8"-F	G1/4"-M	M20x1.5-M	145.0	99.5	13	8.5	40	24	17	17	75
FSTE-HD G1/4-AG 75 VG	G1/8"-F	G1/4"-M	M20x1.5-M	145.0	99.5	13	8.5	40	24	17	17	75
FSTE-HD G1/4-AG 90 VG	G1/8"-F	G1/4"-M	M20x1.5-M	160.0	114.3	12	8.5	40	24	17	17	90
FSTE-HD G3/8-AG 25	G3/8"-F	G3/8"-M	M30x1.5-M	106.0	41.0	12	10.0	53	36	24	24	25



# Spring Plungers FSTE-HD

Stroke from 15 mm to 90 mm



## Design Data Spring Plungers FSTE-HD

Type	G1	G2	G3	H [mm]	H2 [mm]	LG1 [mm]	LG2 [mm]	LG3 [mm]	SW1 [mm]	SW2 [mm]	SW3 [mm]	Z (Stroke) [mm]
FSTE-HD G3/8-AG 25 VG	G3/8"-F	G3/8"-M	M30x1.5-M	106.0	41.0	13	10.0	53	36	24	24	25
FSTE-HD G3/8-AG 75	G3/8"-F	G3/8"-M	M30x1.5-M	177.0	112.0	12	10.0	53	36	24	24	75
FSTE-HD G3/8-AG 75 VG	G3/8"-F	G3/8"-M	M30x1.5-M	177.0	112.0	13	10.0	53	36	24	24	75
FSTE-HD G3/8-AG 90	G3/8"-F	G3/8"-M	M30x1.5-M	189.0	124.0	12	10.0	53	36	24	24	90
FSTE-HD G3/8-AG 90 VG	G3/8"-F	G3/8"-M	M30x1.5-M	189.0	124.0	13	10.0	53	36	24	24	90
FSTE-HD G1/2-AG 25	G3/8"-F	G1/2"-M	M30x1.5-M	105.5	40.5	12	10.5	53	36	24	24	25
FSTE-HD G1/2-AG 25 VG	G3/8"-F	G1/2"-M	M30x1.5-M	105.5	40.5	13	10.5	53	36	24	24	25
FSTE-HD G1/2-AG 75	G3/8"-F	G1/2"-M	M30x1.5-M	176.5	111.5	12	10.5	53	36	24	24	75
FSTE-HD G1/2-AG 75 VG	G3/8"-F	G1/2"-M	M30x1.5-M	176.5	111.5	13	10.5	53	36	24	24	75
FSTE-HD G1/2-AG 90	G3/8"-F	G1/2"-M	M30x1.5-M	188.5	123.5	12	10.5	53	36	24	24	90
FSTE-HD G1/2-AG 90 VG	G3/8"-F	G1/2"-M	M30x1.5-M	188.5	123.5	13	10.5	53	36	24	24	90

Schmalz –  
The Company

Vacuum  
Suction Cups

Special  
Grippers

Gripping  
Systems

Clamping  
Systems

Mounting  
Elements

Vacuum  
Generators

Valve  
Technology

Switches and  
Monitoring

Filters and  
Connections

Services

Contact

Glossary

Index of  
Products



Stroke from 15 mm to 80 mm



## Suitability for Industry Specific Applications

### Applications

- Spring plunger with special sliding bearings and one damping spring for handling of workpieces with differing heights, such as curved metal sheets, etc.
- Handling of easily damaged workpieces (such as sheets of glass) without additional control functions to prevent damage, since the plunger ensures soft placement
- For handling tasks with very dynamic motion and short cycle times
- Extra smooth running, anti-rotation design for process secured operation even under harsh and difficult conditions



Spring Plungers FSTE-HDB

### Design

- Spring plunger consisting of high strength stainless steel rod, brass sleeve with integrated bearing (2) and damping spring (4)
- Plunger rod with integrated vacuum feed, always female connection thread (1)
- Ball bearing anti-rotation guard
- Always male connection thread for suction cup (5)
- Long external mounting thread with lock nuts (3)
- Block guard for damping spring

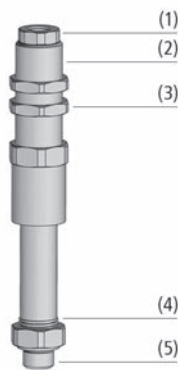

System Design Spring Plungers FSTE-HDB

### Our Highlights...

- Spring plunger with high quality sliding bearings
- Very smooth running, anti-rotation design
- Long external thread for fastening with two locknuts
- Block guard for damping spring

### Your Benefits...

- Maintenance free, with extremely long operating lifetime; suitable for short cycle times
- For oval suction cups in demanding applications
- Large and flexible adjustment range
- Ensures long life time of spring

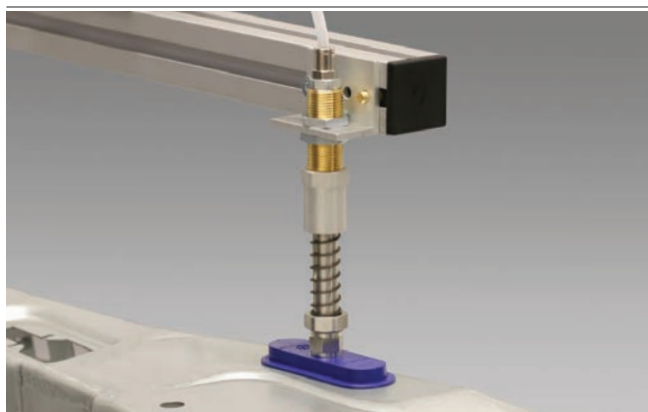

Spring Plunger FSTE-HDB handling sheet metals

# Spring Plungers FSTE-HDB

Stroke from 15 mm to 80 mm



## Designation Code Spring Plungers FSTE-HDB

<b>FSTE</b>	-	<b>HDB</b>	-	<b>G1/4-AG</b>	-	<b>25</b>	-	<b>VG-AB</b>
<b>1</b>		<b>2</b>		<b>3</b>		<b>4</b>		<b>5</b>

### 1 – Abbreviated designation

Code	Version
FSTE	FSTE

### 2 – Variant

Code	Type
HDB	Heavy duty ball (ball bearing-mounted anti-rotation guard)

### 3 – Suction cup connection

Code	Connection
G1/8-AG	G1/8-AG (AG = male (M))
G1/4-AG	G1/4-AG
G3/8-AG	G3/8-AG
G1/2-AG	G1/2-AG

### 4 – Plunger stroke

Code	Plunger stroke in mm
15...80	15 to 80

### 5 – Product addition

Code	Type
VG-AB	Anti-rotation guard, anti block

Spring plunger FSTE-HDB is delivered as a ready-to-connect product.



## Ordering Data Spring Plungers FSTE-HDB

Type*		Plunger stroke in mm:			
		15	25	45	80
FSTE-HDB	G1/8-AG	10.01.02.01437	10.01.02.01438	10.01.02.01439	-
FSTE-HDB	G1/4-AG	-	10.01.02.01427	10.01.02.01382	10.01.02.01377
FSTE-HDB	G3/8-AG	-	10.01.02.01436	10.01.02.01422	10.01.02.01423
FSTE-HDB	G1/2-AG	-	10.01.02.01440	-	10.01.02.01441

\*Recommendation: To raise the lifetime in continuous operation, prevent the maximal slide stroke



## Technical Data Spring Plungers FSTE-HDB

Type	Spring rate [N/mm]	Spring pretension [N/mm]	Spring force, center [N]*	Vertical load [N]**	Horizontal load [N]***	Weight [g]	Operating temperature [°C]
FSTE-HDB G1/8-AG 15 VG-AB	0.211	3.8	5.42	3,700	385	130	0 ... 80
FSTE-HDB G1/8-AG 25 VG-AB	0.143	3.7	5.51	3,700	283	137	0 ... 80
FSTE-HDB G1/8-AG 45 VG-AB	0.097	3.6	5.77	3,700	173	149	0 ... 80
FSTE-HDB G1/4-AG 25 VG-AB	0.711	3.1	11.95	2,400	747	235	0 ... 80
FSTE-HDB G1/4-AG 45 VG-AB	0.453	3.5	13.71	2,400	466	253	0 ... 80
FSTE-HDB G1/4-AG 80 VG-AB	0.417	12.4	29.06	2,400	340	298	0 ... 80
FSTE-HDB G3/8-AG 25 VG-AB	0.711	3.1	11.95	2,400	747	240	0 ... 80
FSTE-HDB G3/8-AG 45 VG-AB	0.453	3.5	13.71	2,400	466	256	0 ... 80
FSTE-HDB G3/8-AG 80 VG-AB	0.417	12.4	29.06	2,400	340	304	0 ... 80
FSTE-HDB G1/2-AG 25 VG-AB	3.828	4.6	52.50	4,900	1,870	590	0 ... 80
FSTE-HDB G1/2-AG 80 VG-AB	1.072	21.5	64.50	4,900	800	725	0 ... 80

\*Referred to 50 % of operating stroke

\*\*Maximum static loading

\*\*\*The specification of the horizontal load refers to the lower edge of the plunger with extended spring. It is a maximum static stress and it impairs the spring compression and extension in horizontal position.



# Spring Plungers FSTE-HDB

Stroke from 15 mm to 80 mm

**Design Data Spring Plungers FSTE-HDB**

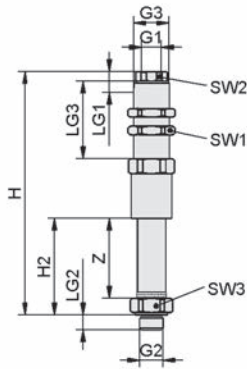

FSTE-HDB

Type	G1	G2	G3	H [mm]	H2 [mm]	LG1 [mm]	LG2 [mm]	LG3 [mm]	SW1 [mm]	SW2 [mm]	SW3 [mm]	Z (Stroke) [mm]
FSTE-HDB G1/8-AG 15 VG-AB	G1/8"-F	G1/8"-M	M16x1-M	93	23	7	8.5	34	22	12	19	15
FSTE-HDB G1/8-AG 25 VG-AB	G1/8"-F	G1/8"-M	M16x1-M	106	33	7	8.5	34	22	12	19	25
FSTE-HDB G1/8-AG 45 VG-AB	G1/8"-F	G1/8"-M	M16x1-M	131	53	7	8.5	34	22	12	19	45
FSTE-HDB G1/4-AG 25 VG-AB	G1/8"-F	G1/4"-M	M20x1.5-M	119	35	12	8.5	44	24	17	22	25
FSTE-HDB G1/4-AG 45 VG-AB	G1/8"-F	G1/4"-M	M20x1.5-M	139	55	12	8.5	44	24	17	22	45
FSTE-HDB G1/4-AG 80 VG-AB	G1/8"-F	G1/4"-M	M20x1.5-M	189	90	12	8.5	44	24	17	22	80
FSTE-HDB G3/8-AG 25 VG-AB	G1/8"-F	G3/8"-M	M20x1.5-M	119	36	12	8.0	44	24	17	22	25
FSTE-HDB G3/8-AG 45 VG-AB	G1/8"-F	G3/8"-M	M20x1.5-M	139	56	12	8.0	44	24	17	22	45
FSTE-HDB G3/8-AG 80 VG-AB	G1/8"-F	G3/8"-M	M20x1.5-M	189	91	12	8.0	44	24	17	22	80
FSTE-HDB G1/2-AG 25 VG-AB	G3/8"-F	G1/2"-M	M30x1.5-M	137	37	16	10.5	50	36	24	32	25
FSTE-HDB G1/2-AG 80 VG-AB	G3/8"-F	G1/2"-M	M30x1.5-M	217	92	16	10.5	50	36	24	32	80

# Spring Plungers FSTA

Stroke from 25 mm to 90 mm



Spring Plungers FSTA

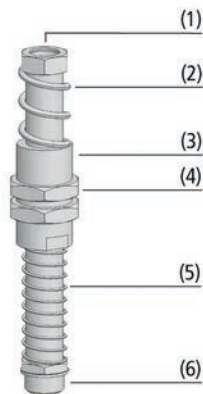

System Design Spring Plungers FSTA



Mounting example Spring Plungers FSTA

## Suitability for Industry Specific Applications

### Applications

- Spring plunger with two damping springs for handling of workpieces with differing heights, such as curved metal sheets, etc.
- Handling of sensitive workpieces (such as sheets of glass) without additional control functions to prevent damage, since the plunger ensures soft placement

### Design

- Spring plunger consisting of a high strength rod made of galvanized steel, guide sleeve (3) and upper (2) and lower (5) damping springs
- Plunger rod with integrated vacuum feed, always female connection thread (1)
- Thread for suction cup is always a male thread (6)
- Two lock nuts for attachment (4)

### Our Highlights...

- Spring plunger with two damping springs
- Upper damping spring with high spring rate

### Your Benefits...

- Soft placement of the suction cup on easily damaged workpieces; good compensation for varying workpiece heights
- Prevention of excessive stroke lengths; uniform load distribution

# Spring Plungers FSTA

Stroke from 25 mm to 90 mm



## Designation Code Spring Plungers FSTA

<b>FSTA</b>	-	<b>G1/2-AG</b>	-	<b>25</b>
<b>1</b>		<b>2</b>		<b>3</b>

### 1 – Abbreviated designation

Code	Version
FSTA	FSTA

### 2 – Suction cup connection

Code	Connection
G1/4-AG	G1/4-AG (AG = male (M))
G1/2-AG	G1/2-AG

### 3 – Plunger stroke

Code	Plunger stroke in mm
25...90	25 to 90

Spring plunger FSTA is delivered as a ready-to-connect product.



## Ordering Data Spring Plungers FSTA

Type	Part no.
FSTA G1/4-AG 25	10.01.02.00572
FSTA G1/4-AG 50	10.01.02.00573
FSTA G1/2-AG 25	10.01.02.00577
FSTA G1/2-AG 50	10.01.02.00578
FSTA G1/2-AG 90	10.01.02.00579



## Technical Data Spring Plungers FSTA

Type	Spring rate [N/mm]	Spring pretension [N/mm]	Spring force, center [N]*	Vertical load [N]**	Horizontal load [N]***	Weight [g]	Operating temperature [°C]
FSTA G1/4-AG 25	0.8	9	18	2,400	800	185	0 ... 80
FSTA G1/4-AG 50	0.3	15	21	2,400	490	210	0 ... 80
FSTA G1/2-AG 25	3.9	26	74	4,900	1,870	493	0 ... 80
FSTA G1/2-AG 50	1.9	4	50	4,900	1,200	539	0 ... 80
FSTA G1/2-AG 90	1.1	25	76	4,900	730	645	0 ... 80

\*Referred to 50 % of operating stroke

\*\*Maximum static loading

\*\*\*The specification of the horizontal load refers to the lower edge of the plunger with extended spring. It is a maximum static stress and it impairs the spring compression and extension in horizontal position.



# Spring Plungers FSTA

Stroke from 25 mm to 90 mm



## Design Data Spring Plungers FSTA

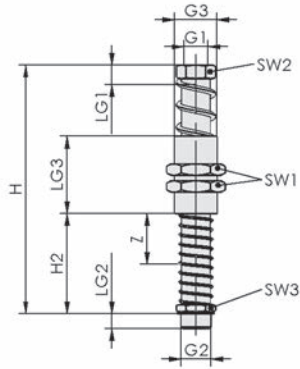

FSTA

Type	G1	G2	G3	H [mm]	H2 [mm]	LG1 [mm]	LG2 [mm]	LG3 [mm]	SW1 [mm]	SW2 [mm]	SW3 [mm]	Z (Stroke) [mm]
FSTA G1/4-AG 25	G1/8"-F	G1/4"-M	M20x1.5-M	115	37	12	9	40	24	17	17	25
FSTA G1/4-AG 50	G1/8"-F	G1/4"-M	M20x1.5-M	144	67	12	9	40	24	17	17	50
FSTA G1/2-AG 25	G3/8"-F	G1/2"-M	M30x1.5-M	147	43	12	11	55	36	24	24	25
FSTA G1/2-AG 50	G3/8"-F	G1/2"-M	M30x1.5-M	177	73	12	11	55	36	24	24	50
FSTA G1/2-AG 90	G3/8"-F	G1/2"-M	M30x1.5-M	230	126	12	11	55	36	24	24	90

Schmalz – The Company  
Vacuum Suction Cups  
Special Grippers  
Gripping Systems  
Clamping Systems  
Mounting Elements  
Vacuum Generators  
Valve Technology  
Switches and Monitoring  
Filters and Connections  
Services  
Contact  
Glossary  
Index of Products



# Spring Plungers FSTA-HD

Stroke from 25 mm to 90 mm



Spring Plungers FSTA-HD

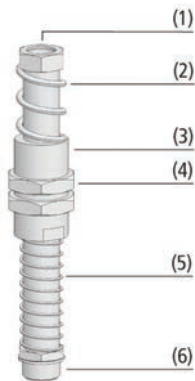

System Design Spring Plungers FSTA-HD

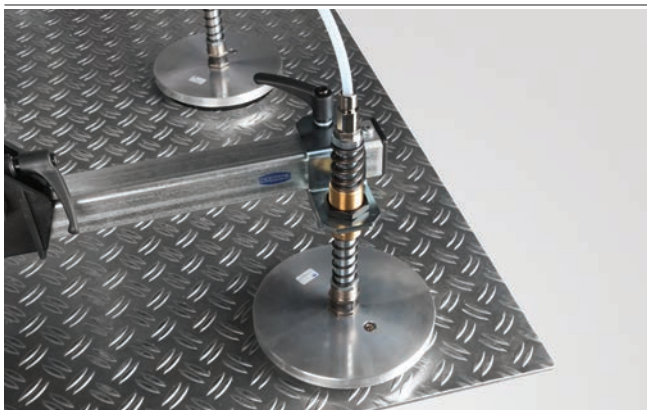

Mounting example Spring Plungers FSTA-HD

## Suitability for Industry Specific Applications

### Applications

- Spring plunger with two damping springs and special sliding bearings for handling of workpieces with differing heights, such as curved metal sheets, etc.
- Handling of sensitive workpieces (such as sheets of glass) without additional control functions to prevent damage, since the plunger ensures soft placement
- For use under rough operating conditions
- For handling tasks with very dynamic motion and short cycle times

### Design

- Spring plunger consisting of high-strength steel rod, guide sleeve (3) with integrated bearing and lower (5) and upper (2) damping spring
- Plunger rod with integrated vacuum feed, always female connection thread (1)
- Anti-rotation guard due to flat side on the rod and a correspondingly shaped guide sleeve
- Thread for suction cup is always a male thread (6)
- Two lock nuts (4) for attachment

### Our Highlights...

- Spring plunger with high quality sliding bearings and specially machined plunger rod
- Spring plunger with two damping springs, optionally available with anti-rotation guard
- Wide range of different connection threads and stroke lengths

### Your Benefits...

- Maintenance free, with extremely long operating lifetime; suitable for short cycle times
- Guarantees soft placement on easily damaged workpieces. Absorbs shocks and vibration. Prevents excessively long strokes
- Available for a wide range of applications and for all suction cups of the standard range

- Schmalz – The Company
- Vacuum Suction Cups
- Special Grippers
- Gripping Systems
- Clamping Systems
- Mounting Elements
- Vacuum Generators
- Valve Technology
- Switches and Monitoring
- Filters and Connections
- Services
- Contact
- Glossary
- Index of Products



Stroke from 25 mm to 90 mm



## Designation Code Spring Plungers FSTA-HD

FSTA	-	HD	-	G1/4-AG	-	50	-	VG
1		2		3		4		5

## 1 – Abbreviated designation

Code	Version
FSTA	FSTA

## 2 – Variant

Code	Type
HD	Heavy duty

## 3 – Suction cup connection

Code	Connection
G1/4-AG	G1/4-AG (AG = male (M))
G3/8-AG	G3/8-AG
G1/2-AG	G1/2-AG

## 4 – Plunger stroke

Code	Plunger stroke in mm
25...90	25 to 90

## 5 – Product addition

Code	Type
VG	With anti-rotation guard

Spring plunger FSTA-HD is delivered as a ready-to-connect product.



## Ordering Data Spring Plungers FSTA-HD

Type*	Plunger stroke in mm:			50	90
	25				
FSTA-HD G1/4-AG -	10.01.02.00777			10.01.02.00778	-
FSTA-HD G1/4-AG VG	10.01.02.00884			10.01.02.00885	-
FSTA-HD G3/8-AG -	10.01.02.00814			10.01.02.00815	10.01.02.00816
FSTA-HD G3/8-AG VG	10.01.02.00886			10.01.02.00887	10.01.02.00888
FSTA-HD G1/2-AG -	10.01.02.00779			10.01.02.00780	10.01.02.00781
FSTA-HD G1/2-AG VG	10.01.02.00889			10.01.02.00890	10.01.02.00891

\*Recommendation: To raise the lifetime in continuous operation, prevent the maximal slide stroke



## Technical Data Spring Plungers FSTA-HD

Type	Spring rate [N/mm]	Spring pretension [N/mm]	Spring force, center [N]*	Vertical load [N]**	Horizontal load [N]***	Weight [g]	Operating temperature [°C]
FSTA-HD G1/4-AG 25	0.711	8.95	17.8	2,400	800	185	0 ... 80
FSTA-HD G1/4-AG 25 VG	0.711	8.95	17.8	2,400	800	185	0 ... 80
FSTA-HD G1/4-AG 50	0.262	14.10	20.6	2,400	490	210	0 ... 80
FSTA-HD G1/4-AG 50 VG	0.262	14.10	20.6	2,400	490	210	0 ... 80
FSTA-HD G3/8-AG 25	3.828	25.65	73.5	4,800	1,870	495	0 ... 80
FSTA-HD G3/8-AG 25 VG	3.828	25.65	73.5	4,800	1,870	495	0 ... 80
FSTA-HD G3/8-AG 50	1.810	3.95	49.2	4,800	1,200	540	0 ... 80
FSTA-HD G3/8-AG 50 VG	1.810	3.95	49.2	4,800	1,200	540	0 ... 80
FSTA-HD G3/8-AG 90	1.072	24.38	75.3	4,800	730	645	0 ... 80
FSTA-HD G3/8-AG 90 VG	1.072	24.38	75.3	4,800	730	645	0 ... 80
FSTA-HD G1/2-AG 25	3.828	25.65	73.5	4,900	1,870	493	0 ... 80
FSTA-HD G1/2-AG 25 VG	3.828	25.65	73.5	4,900	1,870	495	0 ... 80
FSTA-HD G1/2-AG 50	1.810	3.95	49.2	4,900	1,200	539	0 ... 80
FSTA-HD G1/2-AG 50 VG	1.810	3.95	49.2	4,900	1,200	540	0 ... 80
FSTA-HD G1/2-AG 90	1.072	24.38	75.3	4,900	730	645	0 ... 80
FSTA-HD G1/2-AG 90 VG	1.072	24.38	75.3	4,900	730	645	0 ... 80

\*Referred to 50 % of operating stroke

\*\*Maximum static loading

\*\*\*The specification of the horizontal load refers to the lower edge of the plunger with extended spring. It is a maximum static stress and it impairs the spring compression and extension in horizontal position.



# Spring Plungers FSTA-HD

Stroke from 25 mm to 90 mm

## Design Data Spring Plungers FSTA-HD

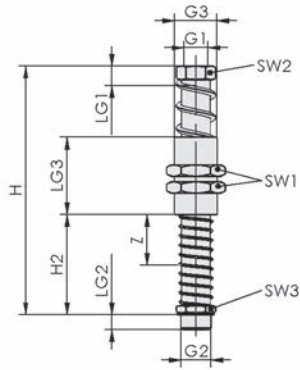

FSTA-HD

Type	G1	G2	G3	H [mm]	H2 [mm]	LG1 [mm]	LG2 [mm]	LG3 [mm]	SW1 [mm]	SW2 [mm]	SW3 [mm]	Z (Stroke) [mm]
FSTA-HD G1/4-AG 25	G1/8"-F	G1/4"-M	M20x1.5-M	114.5	37.5	12	8.5	40	24	17	17	25
FSTA-HD G1/4-AG 25 VG	G1/8"-F	G1/4"-M	M20x1.5-M	114.5	37.0	12	8.5	40	24	17	17	25
FSTA-HD G1/4-AG 50	G1/8"-F	G1/4"-M	M20x1.5-M	144.0	67.0	12	8.5	40	24	17	17	50
FSTA-HD G1/4-AG 50 VG	G1/8"-F	G1/4"-M	M20x1.5-M	144.0	66.5	12	8.5	40	24	17	17	50
FSTA-HD G3/8-AG 25	G3/8"-F	G3/8"-M	M30x1.5-M	146.5	40.8	12	10.5	53	36	24	24	25
FSTA-HD G3/8-AG 25 VG	G3/8"-F	G3/8"-M	M30x1.5-M	147.0	40.8	12	10.5	53	36	24	24	25
FSTA-HD G3/8-AG 50	G3/8"-F	G3/8"-M	M30x1.5-M	176.5	70.8	12	10.5	53	36	24	24	50
FSTA-HD G3/8-AG 50 VG	G3/8"-F	G3/8"-M	M30x1.5-M	177.0	70.8	12	10.5	53	36	24	24	50
FSTA-HD G3/8-AG 90	G3/8"-F	G3/8"-M	M30x1.5-M	229.5	123.8	12	10.5	53	36	24	24	90
FSTA-HD G3/8-AG 90 VG	G3/8"-F	G3/8"-M	M30x1.5-M	230.0	123.8	12	10.5	53	36	24	24	90
FSTA-HD G1/2-AG 25	G3/8"-F	G1/2"-M	M30x1.5-M	146.5	40.3	12	10.5	53	36	24	24	25
FSTA-HD G1/2-AG 25 VG	G3/8"-F	G1/2"-M	M30x1.5-M	146.5	40.3	12	10.5	53	36	24	24	25
FSTA-HD G1/2-AG 50	G3/8"-F	G1/2"-M	M30x1.5-M	176.5	70.3	12	10.5	53	36	24	24	50
FSTA-HD G1/2-AG 50 VG	G3/8"-F	G1/2"-M	M30x1.5-M	176.5	70.3	12	10.5	53	36	24	24	50
FSTA-HD G1/2-AG 90	G3/8"-F	G1/2"-M	M30x1.5-M	229.5	123.3	12	10.5	53	36	24	24	90
FSTA-HD G1/2-AG 90 VG	G3/8"-F	G1/2"-M	M30x1.5-M	229.5	123.3	12	10.5	53	36	24	24	90

# Spring Plungers FSTI

Stroke from 10 mm to 50 mm



Spring Plungers FSTI

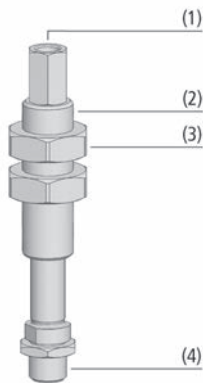

System Design Spring Plungers FSTI



Mounting example Spring Plungers FSTI

## Suitability for Industry Specific Applications

### Applications

- Spring plunger with internal damping spring for handling of workpieces with differing heights, such as curved metal sheets, etc.
- Handling of sensitive workpieces (such as sheets of glass) without additional control functions to prevent damage, since the plunger ensures soft placement
- Particularly suitable for handling tasks in the automotive sector

### Design

- Spring plunger consisting of high strength steel rod, guide sleeve with integrated sliding bearing (2) and internal damping spring
- Connection thread for suction cup male (4); connection thread for vacuum supply (1) either female or male
- Two lock nuts (3) for attachment
- Burnished surface; on the version with anti-rotation function, the plunger rod is coated for optimum sliding behaviour
- Plunger rod with integrated vacuum feed
- Anti-rotation guard due to flat side on the rod and a correspondingly shaped guide sleeve

### Our Highlights...

- Spring plunger with high quality sliding bearings and excellent guidance
- Internal damping spring
- Minimum overall height; weight optimized
- Available with anti-rotation guard

### Your Benefits...

- Very economical operation, since no maintenance needed
- Soft placement on easily damaged workpieces; spring protected against dirt and external mechanical forces
- Suitable for use in very small spaces and with highly dynamic motion
- Suitable for use with oval suction cups

Schmalz – The Company

Vacuum Suction Cups

Special Grippers

Gripping Systems

Clamping Systems

Mounting Elements

Vacuum Generators

Valve Technology

Switches and Monitoring

Filters and Connections

Services

Contact

Glossary

Index of Products



# Spring Plungers FSTI

Stroke from 10 mm to 50 mm



## Designation Code Spring Plungers FSTI

<b>FSTI</b>	-	<b>G1/4-AG</b>	-	<b>G1/8-AG</b>	-	<b>10</b>	-	<b>VG</b>
<b>1</b>		<b>2</b>		<b>3</b>		<b>4</b>		<b>5</b>

### 1 – Abbreviated designation

Code	Version
FSTI	FSTI

### 2 – Suction cup connection

Code	Connection
G1/4-AG	G1/4-AG (AG = male (M))
G3/8-AG	G3/8-AG

### 3 – Vacuum connection

Code	Connection
G1/8-AG	G1/8-AG (AG = male (M))
G1/8-IG	G1/8-IG (IG = female (F))

### 4 – Plunger stroke

Code	Plunger stroke in mm
10...50	10 to 50

### 5 – Product addition

Code	Type
VG	With anti-rotation guard

The spring plunger FSTI is delivered as a ready-to-connect product.



## Ordering Data Spring Plungers FSTI

Type*				Plunger stroke in mm: **		
				10	25	50
FSTI	G1/4-AG	G1/8-AG	-	10.01.02.00864	10.01.02.00868	10.01.02.00992
FSTI	G1/4-AG	G1/8-AG	VG	10.01.02.00865	10.01.02.00869	10.01.02.00993
FSTI	G1/4-AG	G1/8-IG	-	10.01.02.00866	10.01.02.00870	10.01.02.00994
FSTI	G1/4-AG	G1/8-IG	VG	10.01.02.00867	10.01.02.00871	10.01.02.00995
FSTI	G3/8-AG	G1/8-AG	-	10.01.02.00755	10.01.02.00843	10.01.02.00996
FSTI	G3/8-AG	G1/8-AG	VG	10.01.02.00860	10.01.02.00862	10.01.02.00997
FSTI	G3/8-AG	G1/8-IG	-	10.01.02.00851	10.01.02.00850	10.01.02.00998
FSTI	G3/8-AG	G1/8-IG	VG	10.01.02.00861	10.01.02.00863	10.01.02.00999

\*VG = Version with anti-rotation guard for repeatably accurate positioning of suction cups

\*\*Recommendation: To raise the lifetime in continuous operation, prevent the maximal slide stroke



## Technical Data Spring Plungers FSTI

Type	Spring rate [N/mm]	Spring pretension [N/mm]	Spring force, center [N]*	Vertical load [N]**	Horizontal load [N]***	Weight [g]	Operating temperature [°C]
FSTI G1/4-AG G1/8-AG 10	0.097	7.08	7.57	1,000	700	150	0 ... 80
FSTI G1/4-AG G1/8-AG 10 VG	0.097	7.08	7.57	1,000	500	150	0 ... 80
FSTI G1/4-AG G1/8-IG 10	0.097	7.08	7.57	1,000	700	150	0 ... 80
FSTI G1/4-AG G1/8-IG 10 VG	0.097	7.08	7.57	1,000	500	150	0 ... 80
FSTI G1/4-AG G1/8-AG 25	0.097	5.63	6.84	1,000	700	180	0 ... 80
FSTI G1/4-AG G1/8-AG 25 VG	0.097	5.63	6.84	1,000	500	180	0 ... 80
FSTI G1/4-AG G1/8-IG 25	0.097	5.63	6.84	1,000	700	180	0 ... 80
FSTI G1/4-AG G1/8-IG 25 VG	0.097	5.63	6.84	1,000	500	180	0 ... 80
FSTI G1/4-AG G1/8-AG 50	0.097	2.30	4.70	1,000	700	230	0 ... 80
FSTI G1/4-AG G1/8-AG 50 VG	0.097	2.30	4.70	1,000	500	230	0 ... 80
FSTI G1/4-AG G1/8-IG 50	0.097	2.30	4.70	1,000	700	230	0 ... 80
FSTI G1/4-AG G1/8-IG 50 VG	0.097	2.30	4.70	1,000	500	230	0 ... 80
FSTI G3/8-AG G1/8-AG 10	0.097	7.08	7.57	1,000	700	150	0 ... 80
FSTI G3/8-AG G1/8-AG 10 VG	0.097	7.08	7.57	1,000	500	150	0 ... 80



Stroke from 10 mm to 50 mm



## Technical Data Spring Plungers FSTI

Type	Spring rate [N/mm]	Spring pretension [N/mm]	Spring force, center [N]*	Vertical load [N]**	Horizontal load [N]***	Weight [g]	Operating temperature [°C]
FSTI G3/8-AG G1/8-IG 10	0.097	7.08	7.57	1,000	700	150	0 ... 80
FSTI G3/8-AG G1/8-IG 10 VG	0.097	7.08	7.57	1,000	500	150	0 ... 80
FSTI G3/8-AG G1/8-AG 25	0.097	5.63	6.84	1,000	700	180	0 ... 80
FSTI G3/8-AG G1/8-AG 25 VG	0.097	5.63	6.84	1,000	500	180	0 ... 80
FSTI G3/8-AG G1/8-IG 25	0.097	5.63	6.84	1,000	700	180	0 ... 80
FSTI G3/8-AG G1/8-IG 25 VG	0.097	5.63	6.84	1,000	500	180	0 ... 80
FSTI G3/8-AG G1/8-IG 50	0.097	2.30	4.70	1,000	700	230	0 ... 80
FSTI G3/8-AG G1/8-IG 50 VG	0.097	2.30	4.70	1,000	500	230	0 ... 80
FSTI G3/8-AG G1/8-AG 50	0.097	2.30	4.70	1,000	700	230	0 ... 80
FSTI G3/8-AG G1/8-AG 50 VG	0.097	2.30	4.70	1,000	500	230	0 ... 80

\*Referred to 50 % of operating stroke

\*\*Maximum static loading

\*\*\*The specification of the horizontal load refers to the lower edge of the plunger with extended spring. It is a maximum static stress and it impairs the spring compression and extension in horizontal position.



## Design Data Spring Plungers FSTI

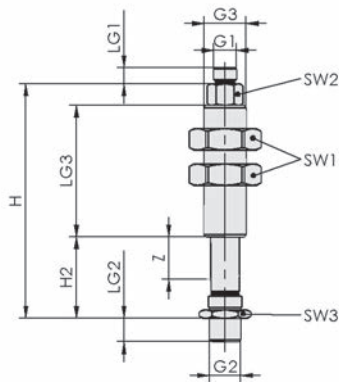

FSTI AG/AG (VG)

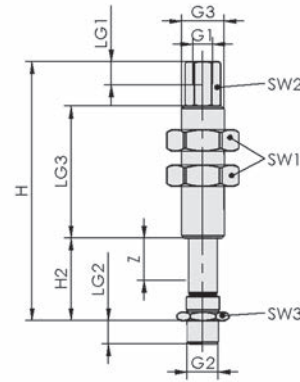

FSTI AG/IG (VG)

Type	G1	G2	G3	H [mm]	H2 [mm]	LG1 [mm]	LG2 [mm]	LG3 [mm]	SW1 [mm]	SW2 [mm]	SW3 [mm]	Z (Stroke) [mm]
FSTI G1/4-AG G1/8-AG 10	G1/8"-M	G1/4"-M	M18x1.5-M	71.0	21.0	6.5	10	41	27	13	17	10
FSTI G1/4-AG G1/8-AG 10 VG	G1/8"-M	G1/4"-M	M18x1.5-M	71.0	21.0	6.5	10	41	27	13	17	10
FSTI G1/4-AG G1/8-IG 10	G1/8"-F	G1/4"-M	M18x1.5-M	82.5	19.5	12.0	10	41	27	13	17	10
FSTI G1/4-AG G1/8-IG 10 VG	G1/8"-F	G1/4"-M	M18x1.5-M	79.5	19.5	12.0	10	41	27	13	17	10
FSTI G1/4-AG G1/8-AG 25	G1/8"-M	G1/4"-M	M18x1.5-M	101.0	36.0	6.5	10	56	27	13	17	25
FSTI G1/4-AG G1/8-AG 25 VG	G1/8"-M	G1/4"-M	M18x1.5-M	101.0	36.0	6.5	10	56	27	13	17	25
FSTI G1/4-AG G1/8-IG 25	G1/8"-F	G1/4"-M	M18x1.5-M	109.5	34.5	12.0	10	56	27	13	17	25
FSTI G1/4-AG G1/8-IG 25 VG	G1/8"-F	G1/4"-M	M18x1.5-M	109.5	34.5	12.0	10	56	27	13	17	25
FSTI G1/4-AG G1/8-AG 50	G1/8"-M	G1/4"-M	M18x1.5-M	163.0	59.0	6.5	8	91	27	13	17	50
FSTI G1/4-AG G1/8-AG 50 VG	G1/8"-M	G1/4"-M	M18x1.5-M	163.0	59.0	6.5	8	91	27	13	17	50
FSTI G1/4-AG G1/8-IG 50	G1/8"-F	G1/4"-M	M18x1.5-M	173.0	59.0	12.0	8	91	27	13	17	50
FSTI G1/4-AG G1/8-IG 50 VG	G1/8"-F	G1/4"-M	M18x1.5-M	173.0	59.0	12.0	8	91	27	13	17	50



Schmalz – The Company  
Vacuum Suction Cups  
Special Grippers  
Gripping Systems  
Clamping Systems  
Mounting Elements  
Vacuum Generators  
Valve Technology  
Switches and Monitoring  
Filters and Connections  
Services  
Contact  
Glossary  
Index of Products

# Spring Plungers FSTI

Stroke from 10 mm to 50 mm



## Design Data Spring Plungers FSTI

Type	G1	G2	G3	H [mm]	H2 [mm]	LG1 [mm]	LG2 [mm]	LG3 [mm]	SW1 [mm]	SW2 [mm]	SW3 [mm]	Z (Stroke) [mm]
FSTI G3/8-AG G1/8-AG 10	G1/8"-M	G3/8"-M	M18x1.5-M	72.0	22.0	6.5	9	41	27	13	19	10
FSTI G3/8-AG G1/8-AG 10 VG	G1/8"-M	G3/8"-M	M18x1.5-M	72.0	22.0	6.5	9	41	27	13	19	10
FSTI G3/8-AG G1/8-IG 10	G1/8"-F	G3/8"-M	M18x1.5-M	82.5	22.5	12.0	9	41	27	13	19	10
FSTI G3/8-AG G1/8-IG 10 VG	G1/8"-F	G3/8"-M	M18x1.5-M	82.5	22.5	12.0	9	41	27	13	19	10
FSTI G3/8-AG G1/8-AG 25	G1/8"-M	G3/8"-M	M18x1.5-M	102.0	37.0	6.5	9	56	27	13	19	25
FSTI G3/8-AG G1/8-AG 25 VG	G1/8"-M	G3/8"-M	M18x1.5-M	102.0	37.0	6.5	9	56	27	13	19	25
FSTI G3/8-AG G1/8-IG 25	G1/8"-F	G3/8"-M	M18x1.5-M	112.5	37.5	12.0	9	56	27	13	19	25
FSTI G3/8-AG G1/8-IG 25 VG	G1/8"-F	G3/8"-M	M18x1.5-M	112.5	37.5	12.0	9	56	27	13	19	25
FSTI G3/8-AG G1/8-AG 50	G1/8"-M	G3/8"-M	M18x1.5-M	163.0	54.0	6.5	8	91	27	13	19	50
FSTI G3/8-AG G1/8-AG 50 VG	G1/8"-M	G3/8"-M	M18x1.5-M	163.0	54.0	6.5	8	91	27	13	19	50
FSTI G3/8-AG G1/8-IG 50	G1/8"-F	G3/8"-M	M18x1.5-M	173.0	54.0	12.0	8	91	27	13	19	50
FSTI G3/8-AG G1/8-IG 50 VG	G1/8"-F	G3/8"-M	M18x1.5-M	173.0	54.0	12.0	8	91	27	13	19	50

- Schmalz – The Company
- Vacuum Suction Cups
- Special Grippers
- Gripping Systems
- Clamping Systems
- Mounting Elements
- Vacuum Generators
- Valve Technology
- Switches and Monitoring
- Filters and Connections
- Services
- Contact
- Glossary
- Index of Products





# Spring Plungers FSTF

Stroke 50 mm

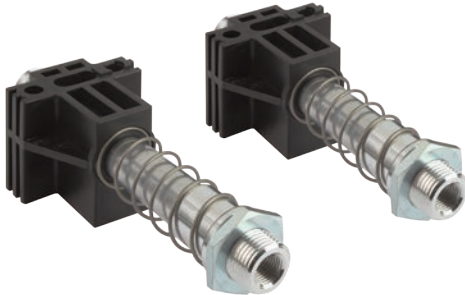

Spring Plungers FSTF

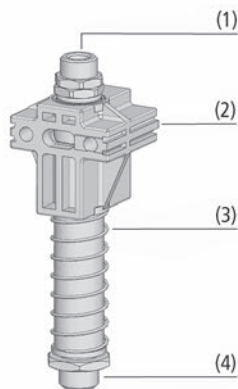

System Design Spring Plungers FSTF



Mounting example Spring Plungers FSTF

## Suitability for Industry Specific Applications

### Applications

- Spring plunger with integrated mounting facilities for handling of workpieces with differing heights
- Handling of sheets and planks of wood in the furniture, chipboard, door and flooring industries
- Handling tasks in dusty surroundings

### Design

- Plastic mounting block (2) with integrated guide for plunger rod (no additional sliding bearing)
- Connection thread for suction cup (4)
- Connection thread for vacuum supply (1)
- Lower damping spring (3)
- Plunger rod made of high-strength aluminum alloy, with integrated anti-blocking device to protect against spring breakage
- Can be mounted with the mounting kit "Standard" or "Comfort" on sectional beams of aluminum

### Our Highlights...

- Variable mounting facility
- Integrated mounting facilities
- Guide and mounting block made of high quality, injection molded plastic

### Your Benefits...

- Individual, flexible and quick adaptation to the intended application
- Can be adapted for use with all common aluminum sectional beam systems
- Price and weight optimized; extremely robust and unaffected by dust

Schmalz – The Company

Vacuum Suction Cups

Special Grippers

Gripping Systems

Clamping Systems

Mounting Elements

Vacuum Generators

Valve Technology

Switches and Monitoring

Filters and Connections

Services

Contact

Glossary

Index of Products



# Spring Plungers FSTF

Stroke 50 mm

Schmalz – The Company  
Vacuum Suction Cups  
Special Grippers  
Gripping Systems  
Clamping Systems  
Mounting Elements  
Vacuum Generators  
Valve Technology  
Switches and Monitoring  
Filters and Connections  
Services  
Contact  
Glossary  
Index of Products

## Designation Code Spring Plungers FSTF



1 – Abbreviated designation		2 – Suction cup connection		3 – Plunger stroke	
Code	Version	Code	Connection	Code	Plunger stroke in mm
FSTF	FSTF	G1/2-AG	G1/2-AG (AG = male (M))	50	50

4 – Product addition	
Code	Type
VG	With anti-rotation guard

Spring plunger FSTF is delivered as a ready-to-connect product.

Available accessories: mounting set

## Ordering Data Spring Plungers FSTF

Type*	Part no.
FSTF G1/2-AG 50	10.01.02.01012
FSTF G1/2-AG 50 VG	10.01.02.01013

\*VG = Version with anti-rotation guard for repeatably accurate positioning of suction cups

## Ordering Data Accessories Spring Plungers FSTF

Type*	Part no.**
Mounting set SET FSTF	10.01.02.01030
Mounting set SET FSTF COM	10.01.02.01031

\*Standard: consisting of two screws ISKT M8x60, 1x guide block with 2x M8, 2x U-washers  
 \*\*Comfort (COM): consisting of one release handle, one screw ISKT M8x60, 1x guide block with 2x M8, 2x U-washers

## Technical Data Spring Plungers FSTF

Type	Spring rate [N/mm]	Spring pretension [N/mm]	Spring force, center [N]*	Vertical load [N]**	Horizontal load [N]***	Weight [g]	Operating temperature [°C]
FSTF G1/2-AG 50	0.567	17.6	31.75	2,500	800	246	0 ... 50
FSTF G1/2-AG 50 VG	0.567	17.6	31.75	2,500	800	250	0 ... 50

\*Referred to 50 % of operating stroke  
 \*\*Maximum static loading  
 \*\*\*The specification of the horizontal load refers to the lower edge of the plunger with extended spring. It is a maximum static stress and it impairs the spring compression and extension in horizontal position.

# Spring Plungers FSTF

Stroke 50 mm



## Design Data Spring Plungers FSTF

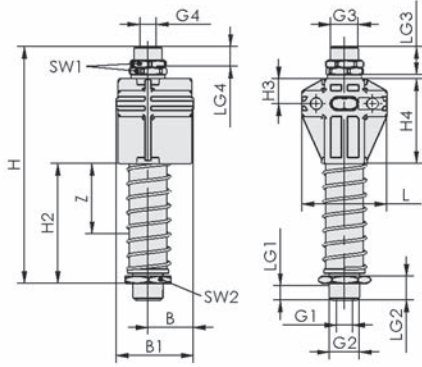

FSTF

Type	B [mm]	B1 [mm]	G1	G2	G3	G4	H [mm]	H2 [mm]	H3 [mm]
FSTF G1/2-AG 50	32.3	54.6	G1/4"-F	G1/2"-M	M20-M	G1/4"-F	168	85	17.5
FSTF G1/2-AG 50 VG	32.3	54.6	G1/4"-F	G1/2"-M	M20-M	G1/4"-F	168	85	17.5

Type	H4 [mm]	L [mm]	LG1 [mm]	LG2 [mm]	LG3 [mm]	LG4 [mm]	SW1 [mm]	SW2 [mm]	Z (Stroke) [mm]
FSTF G1/2-AG 50	60	60	10	17	20	10	24	32	50
FSTF G1/2-AG 50 VG	60	60	10	17	20	10	24	32	50

Schmalz – The Company  
Vacuum Suction Cups  
Special Grippers  
Gripping Systems  
Clamping Systems  
Mounting Elements  
Vacuum Generators  
Valve Technology  
Switches and Monitoring  
Filters and Connections  
Services  
Contact  
Glossary  
Index of Products



Stroke from 25 mm to 75 mm



## Suitability for Industry Specific Applications

### Applications

- Spherically mounted spring plunger with two damping springs, centering spring and special universal ball joint for handling workpieces with height differences
- Handling very sensitive components without additional control requirements (e.g. glass sheets), it ensures that workpieces are set down gently
- Handling very warped and naturally grown materials (e.g. dried wood) without additional technical control requirements
- Use under harsh conditions
- Highly dynamic handling tasks with short cycle times



Suspension Flexible FST-FLEX

### Design

- Spring plunger with stainless steel plunger rod, brass guide sleeve with integrated sliding sleeve, both lower (5) and upper (1) damping spring
- Powder coated plate (2) as attachment to an aluminum section and to hold the automatic centering unit consisting of the centering spring (3) and the spring seat nut (4); the centering spring pretensioning (3) can be set using locking screws in the spring seat nut (4).
- Jointed mounting (6) available as an option
- Powder coated connection plate (7) for connection to an area gripper; the connection plate can be adapted to individual area gripping systems

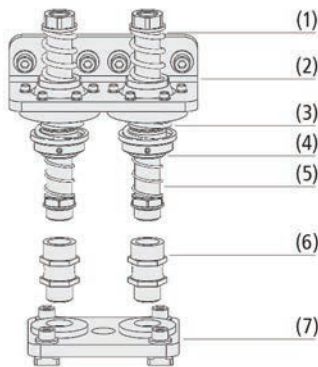

System Design Suspension Flexible FST-FLEX

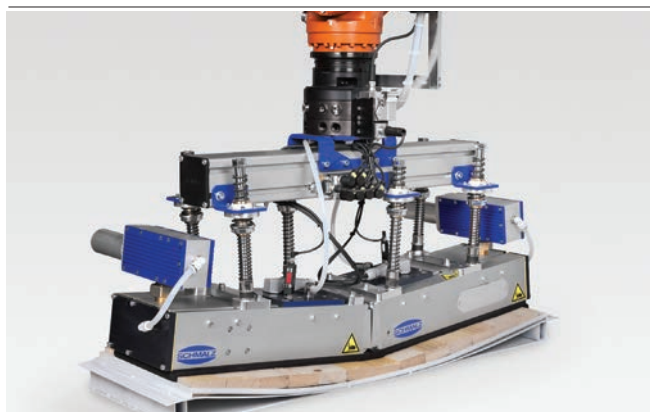

Mounting example suspension flexible FST-FLEX

### Our Highlights...

- Spring plunger with high quality slide bearings and machined plunger rod
- Spring plunger with two damping springs
- Plunger with centering spring and universal ball joint

### Your Benefits...

- Maintenance free with a particularly long service life, suitable for minimal cycle times
- Gentle placement on sensitive workpieces
- Maximum flexibility for extremely uneven workpiece layers

# Suspension Flexible FST-FLEX

Stroke from 25 mm to 75 mm



## Designation Code Suspension Flexible FST-FLEX

<b>FST-FLEX</b>	-	<b>50</b>	-	<b>HD</b>		<b>1</b>	-	<b>G1/2-AG</b>	-	<b>G3/8-IG</b>
<b>1</b>		<b>2</b>		<b>3</b>		<b>4</b>		<b>5</b>		<b>6</b>

### 1 – Abbreviated designation

Code	Version
FST-FLEX	Flexible

### 2 – Plunger stroke

Code	Plunger stroke in mm
25...75	25 to 75

### 3 – Variant

Code	Type
HD	Heavy duty

### 4 – Number of spring plungers

Code	Number
1...2	1 and 2

### 5 – Suction cup connection

Code	Connection
G1/2-AG	G1/2-AG

### 6 – Vacuum connection

Code	Connection
G3/8-IG	G3/8-IG

The flexible suspension FST-FLEX (retaining plate + spring plunger) is supplied as an individual part. To receive a complete flexible suspension (retaining plate + spring plunger + connection plate + accessories), the following ordering steps are required:

- Flexible suspension FST-FLEX (step 1) – retaining plate + spring plunger, avail. with different strokes and no. of spring plungers
- Connection plate FLAN-PL (step 2) – available for different area grippers

Available accessories: Flexolink (FLK), flange plate (FLAN-PL)



## Ordering Data Suspension Flexible FST-FLEX

Type*	Part no.
FST-FLEX 25 HD1 G1/2-AG G3/8-IG	10.01.10.05697
FST-FLEX 50 HD1 G1/2-AG G3/8-IG	10.01.10.05687
FST-FLEX 75 HD1 G1/2-AG G3/8-IG	10.01.10.05698
FST-FLEX 25 HD2 G1/2-AG G3/8-IG	10.01.10.05695
FST-FLEX 50 HD2 G1/2-AG G3/8-IG	10.01.10.05168
FST-FLEX 75 HD2 G1/2-AG G3/8-IG	10.01.10.05696

\*MO-PROF 90x90, 120x120

Type*	Part no.
FST-FLEX 25 HD1 G1/2-AG G3/8-IG	10.01.10.07015
FST-FLEX 50 HD1 G1/2-AG G3/8-IG	10.01.10.07016
FST-FLEX 75 HD1 G1/2-AG G3/8-IG	10.01.10.07017
FST-FLEX 25 HD2 G1/2-AG G3/8-IG	10.01.10.07018
FST-FLEX 50 HD2 G1/2-AG G3/8-IG	10.01.10.07019
FST-FLEX 75 HD2 G1/2-AG G3/8-IG	10.01.10.07020

\*MO-PROF 40x40, 80x40



## Ordering Data Accessories Suspension Flexible FST-FLEX

Type	Part no.
Flange plate	FLAN-PL 120x85x10 ST FLGR 10.01.10.05701
Flange plate	FLAN-PL 400x90x10 ST SBX 10.01.10.05702
Flange plate	FLAN-PL 160x120x10 ST SBX 10.01.10.05706

Type	Part no.
Flexolink	FLK G1/2-IG G1/2-AG 10.01.03.00175
Flexolink	FLK G1/2-IG G1/2-AG V 10.01.03.00207



# Suspension Flexible FST-FLEX

Stroke from 25 mm to 75 mm

## Technical Data Suspension Flexible FST-FLEX

Type	Spring rate [N/mm]	Spring pretension [N/mm]	Spring force, center [N]*	Vertical load [N]**	Weight [g]	Operating temperature [°C]
FST-FLEX 25 HD1 G1/2-AG G3/8-IG	3.828	25.60	74	3,000	1,450	0 ... 80
FST-FLEX 50 HD1 G1/2-AG G3/8-IG	1.810	5.40	51	3,000	1,500	0 ... 80
FST-FLEX 75 HD1 G1/2-AG G3/8-IG	1.072	36.90	78	3,000	1,550	0 ... 80
FST-FLEX 25 HD2 G1/2-AG G3/8-IG	3.828	51.30	147	6,000	2,700	0 ... 80
FST-FLEX 50 HD2 G1/2-AG G3/8-IG	1.810	10.90	102	6,000	2,800	0 ... 80
FST-FLEX 75 HD2 G1/2-AG G3/8-IG	1.072	73.91	155	6,000	2,900	0 ... 80
FST-FLEX 25 HD1 G1/2-AG G3/8-IG	3.828	25.60	74	2,100	1,450	0 ... 80
FST-FLEX 50 HD1 G1/2-AG G3/8-IG	1.810	5.40	51	2,100	1,500	0 ... 80
FST-FLEX 75 HD1 G1/2-AG G3/8-IG	1.072	36.90	78	2,100	1,550	0 ... 80
FST-FLEX 25 HD2 G1/2-AG G3/8-IG	3.828	51.30	147	4,200	2,700	0 ... 80
FST-FLEX 50 HD2 G1/2-AG G3/8-IG	1.810	10.90	102	4,200	2,800	0 ... 80
FST-FLEX 75 HD2 G1/2-AG G3/8-IG	1.072	73.91	155	4,200	2,900	0 ... 80

\*Referred to 50 % of operating stroke

\*\*Maximum static loading

## Design Data Suspension Flexible FST-FLEX

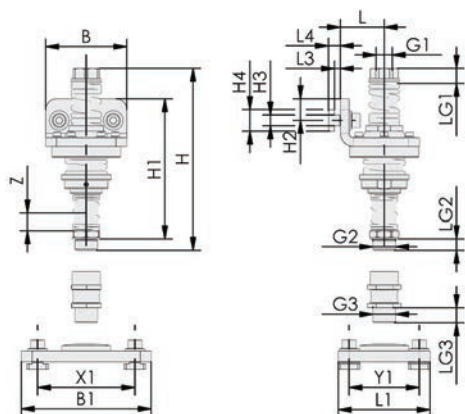

FST-FLEX, FLAN-PL

# Suspension Flexible FST-FLEX

Stroke from 25 mm to 75 mm



## Design Data Suspension Flexible FST-FLEX

Type	B [mm]	G1	G2	G3	H [mm]*	H1 [mm]	H2 [mm]	H3 [mm]	H4 [mm]	L [mm]	L3 [mm]	L4 [mm]	LG1 [mm]	LG2 [mm]	LG3 [mm]	Z (Stroke) [mm]
FST-FLEX 25 HD1 G1/2-AG G3/8-IG	75	G3/8"-F	G1/2"-M	G1/2"-M	168	129	20	10	20	41	6	11	15	11	14	25
FST-FLEX 50 HD1 G1/2-AG G3/8-IG	75	G3/8"-F	G1/2"-M	G1/2"-M	200	161	20	10	20	41	6	11	15	11	14	50
FST-FLEX 75 HD1 G1/2-AG G3/8-IG	75	G3/8"-F	G1/2"-M	G1/2"-M	239	200	20	10	20	41	6	11	15	11	14	75
FST-FLEX 25 HD2 G1/2-AG G3/8-IG	150	G3/8"-F	G1/2"-M	G1/2"-M	168	129	20	10	20	41	6	11	15	11	14	25
FST-FLEX 50 HD2 G1/2-AG G3/8-IG	150	G3/8"-F	G1/2"-M	G1/2"-M	200	161	20	10	20	41	6	11	15	11	14	50
FST-FLEX 75 HD2 G1/2-AG G3/8-IG	150	G3/8"-F	G1/2"-M	G1/2"-M	239	200	20	10	20	41	6	11	15	11	14	75
FST-FLEX 25 HD1 G1/2-AG G3/8-IG	75	G3/8"-F	G1/2"-M	G1/2"-M	168	129	20	10	20	41	2	6	15	11	14	25
FST-FLEX 50 HD1 G1/2-AG G3/8-IG	75	G3/8"-F	G1/2"-M	G1/2"-M	200	161	20	10	20	41	1	6	15	11	14	50
FST-FLEX 75 HD1 G1/2-AG G3/8-IG	75	G3/8"-F	G1/2"-M	G1/2"-M	239	200	20	10	20	41	2	6	15	11	14	75
FST-FLEX 25 HD2 G1/2-AG G3/8-IG	150	G3/8"-F	G1/2"-M	G1/2"-M	168	129	20	10	20	41	2	6	15	11	14	25
FST-FLEX 50 HD2 G1/2-AG G3/8-IG	150	G3/8"-F	G1/2"-M	G1/2"-M	200	161	20	10	20	41	2	6	15	11	14	50
FST-FLEX 75 HD2 G1/2-AG G3/8-IG	150	G3/8"-F	G1/2"-M	G1/2"-M	239	200	20	10	20	41	2	6	15	11	14	75

\*when installed, 33.5 mm higher with Flexolink; 53.0 mm higher with Flexolink in reinforced design

Type	B1 [mm]	L1 [mm]	X1 [mm]	Y1 [mm]
FLAN-PL 120x85x10 ST FLGR	120	85	90	65
FLAN-PL 160x120x10 ST SBX	160	120	120	90
FLAN-PL 400x90x10 ST SBX	400	90	280	65

Schmalz –  
The Company

Vacuum  
Suction Cups

Special  
Grippers

Gripping  
Systems

Clamping  
Systems

Mounting  
Elements

Vacuum  
Generators

Valve  
Technology

Switches and  
Monitoring

Filters and  
Connections

Services

Contact

Glossary

Index of  
Products



# Suspension rigid FST-STARR

Stroke from 25 mm to 75 mm

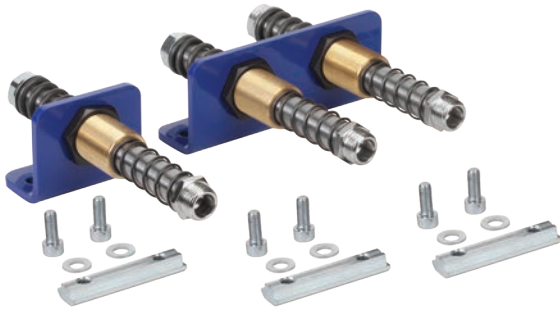

Suspension rigid FST-STARR

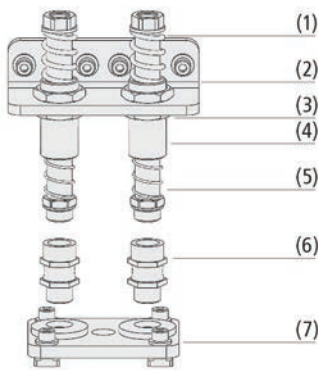

System Design Suspension rigid FST-STARR



Mounting example suspension rigid FST-STARR

## Suitability for Industry Specific Applications

### Applications

- Spring plunger with two damping springs and special slide bearings for handling workpieces with differences in height, e.g. curved sheet metal or wooden parts
- Handling very sensitive components without additional control requirements (e.g. glass sheets), it ensures the workpieces are set down gently
- Handling very warped and naturally grown materials (e.g. dried wood) without additional technical control requirements
- Use under harsh conditions
- Highly dynamic handling tasks with short cycle times

### Design

- Spring plunger with stainless steel plunger rod, brass guide sleeve with integrated sliding sleeve both lower (5) and upper (1) damping spring
- Powder coated retaining plate (2) as attachment to an aluminum section to hold the brass guide sleeve (4) and integrated sliding sleeve; the guide sleeve is attached by two lock nuts (3)
- Jointed mounting (6) available as an option
- Powder coated connection plate (7) for connection to an area gripper; the connection plate can be adapted to individual area gripping systems

### Our Highlights...

- Spring plunger with high quality slide bearings and machined plunger rod
- Spring plunger with two damping springs
- Connection plate for connection to an area gripper

### Your Benefits...

- Maintenance free with a particularly long service life, suitable for minimal cycle times
- Gentle placement on sensitive workpieces; absorbs impacts and vibration; prevents overstroke
- Simple connection to Schmalz F-series and SBX-C area grippers

Schmalz – The Company

Vacuum Suction Cups

Special Grippers

Gripping Systems

Clamping Systems

Mounting Elements

Vacuum Generators

Valve Technology

Switches and Monitoring

Filters and Connections

Services

Contact

Glossary

Index of Products





# Suspension rigid FST-STARR

Stroke from 25 mm to 75 mm



## Designation Code Suspension rigid FST-STARR

<b>FST-STARR</b>	-	<b>50</b>	-	<b>HD</b>		<b>1</b>	-	<b>G1/2-AG</b>	-	<b>G3/8-IG</b>
<b>1</b>		<b>2</b>		<b>3</b>		<b>4</b>		<b>5</b>		<b>6</b>

### 1 – Abbreviated designation

Code	Version
FST-STARR	Rigid

### 2 – Plunger stroke

Code	Plunger stroke in mm
25...75	25 to 75

### 3 – Variant

Code	Type
HD	Heavy duty

### 4 – Number of spring plungers

Code	Number
1...2	1 and 2

### 5 – Suction cup connection

Code	Connection
G1/2-AG	G1/2-AG

### 6 – Vacuum connection

Code	Connection
G3/8-IG	G3/8-IG

The rigid suspension FST-STARR (retaining plate + spring plunger) is supplied as an individual part. To receive a complete rigid suspension (retaining plate + spring plunger + connection plate + accessories), the following ordering steps are required:

- Rigid suspension FST-STARR (step 1) – retaining plate + spring plunger, avail. with different strokes and no. of spring plungers
- Connection plate FLAN-PL (step 2) – available for different area grippers

Available accessories: Flexolink (FLK), flange plate (FLAN-PL)



## Ordering Data Suspension rigid FST-STARR

Type*	Part no.
FST-STARR 25 HD1 G1/2-AG G3/8-IG	10.01.10.05810
FST-STARR 50 HD1 G1/2-AG G3/8-IG	10.01.10.05809
FST-STARR 75 HD1 G1/2-AG G3/8-IG	10.01.10.05808
FST-STARR 25 HD2 G1/2-AG G3/8-IG	10.01.10.05806
FST-STARR 50 HD2 G1/2-AG G3/8-IG	10.01.10.05805
FST-STARR 75 HD2 G1/2-AG G3/8-IG	10.01.10.05803

\*MO-PROF 90x90, 120x120

Type*	Part no.
FST-STARR 25 HD1 G1/2-AG G3/8-IG	10.01.10.07009
FST-STARR 50 HD1 G1/2-AG G3/8-IG	10.01.10.07010
FST-STARR 75 HD1 G1/2-AG G3/8-IG	10.01.10.07011
FST-STARR 25 HD2 G1/2-AG G3/8-IG	10.01.10.07012
FST-STARR 50 HD2 G1/2-AG G3/8-IG	10.01.10.07013
FST-STARR 75 HD2 G1/2-AG G3/8-IG	10.01.10.07014

\*MO-PROF 40x40, 80x40



## Ordering Data Accessories Suspension rigid FST-STARR

Type	Part no.	
Flange plate	FLAN-PL 120x85x10 ST FLGR	10.01.10.05701
Flange plate	FLAN-PL 400x90x10 ST SBX	10.01.10.05702
Flange plate	FLAN-PL 160x120x10 ST SBX	10.01.10.05706

Type	Part no.	
Flexolink	FLK G1/2-IG G1/2-AG	10.01.03.00175
Flexolink	FLK G1/2-IG G1/2-AG V	10.01.03.00207



# Suspension rigid FST-STARR

Stroke from 25 mm to 75 mm

## Technical Data Suspension rigid FST-STARR

Type	Spring rate [N/mm]	Spring pretension [N/mm]	Spring force, center [N]*	Vertical load [N]**	Horizontal load [N]***	Weight [g]	Operating temperature [°C]
FST-STARR 25 HD1 G1/2-AG G3/8-IG	4	26	74	3,000	620	1,200	0 ... 80
FST-STARR 25 HD1 G1/2-AG G3/8-IG	4	26	74	2,100	620	1,200	0 ... 80
FST-STARR 25 HD2 G1/2-AG G3/8-IG	4	52	147	6,000	1,240	2,300	0 ... 80
FST-STARR 25 HD2 G1/2-AG G3/8-IG	4	52	147	4,200	1,240	2,300	0 ... 80
FST-STARR 50 HD1 G1/2-AG G3/8-IG	2	6	51	3,000	480	1,250	0 ... 80
FST-STARR 50 HD1 G1/2-AG G3/8-IG	2	6	51	2,100	480	1,250	0 ... 80
FST-STARR 50 HD2 G1/2-AG G3/8-IG	2	11	102	6,000	960	2,400	0 ... 80
FST-STARR 50 HD2 G1/2-AG G3/8-IG	2	11	102	4,200	960	2,400	0 ... 80
FST-STARR 75 HD1 G1/2-AG G3/8-IG	2	37	78	3,000	400	1,300	0 ... 80
FST-STARR 75 HD1 G1/2-AG G3/8-IG	2	37	78	2,100	400	1,300	0 ... 80
FST-STARR 75 HD2 G1/2-AG G3/8-IG	2	74	155	6,000	800	2,500	0 ... 80
FST-STARR 75 HD2 G1/2-AG G3/8-IG	2	74	155	4,200	800	2,500	0 ... 80

\*Referred to 50 % of operating stroke

\*\*Maximum static loading

\*\*\*The specification of the horizontal load refers to the lower edge of the plunger with extended spring. It is a maximum static stress and it impairs the spring compression and extension in horizontal position.

## Design Data Suspension rigid FST-STARR

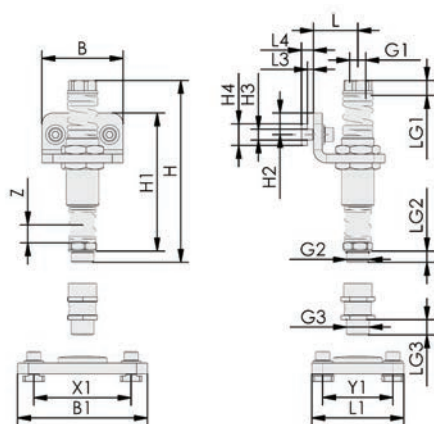

FST-STARR, FLAN-PL

# Suspension rigid FST-STARR

Stroke from 25 mm to 75 mm



## Design Data Suspension rigid FST-STARR

Type	B [mm]	G1	G2	G3	H [mm]*	H1 [mm]	H2 [mm]	H3 [mm]	H4 [mm]	L [mm]	L3 [mm]	L4 [mm]	LG2 [mm]	LG3 [mm]	Z (Stroke) [mm]
FST-STARR 25 HD1 G1/2-AG G3/8-IG	75	G3/8"-F	G1/2"-M	G1/2"-M	167.6	129	20	10	20	41	6	12	11	14	25
FST-STARR 50 HD1 G1/2-AG G3/8-IG	75	G3/8"-F	G1/2"-M	G1/2"-M	199.8	161	20	10	20	41	6	12	11	14	50
FST-STARR 75 HD1 G1/2-AG G3/8-IG	75	G3/8"-F	G1/2"-M	G1/2"-M	238.6	200	20	10	20	41	6	12	11	14	75
FST-STARR 25 HD2 G1/2-AG G3/8-IG	152	G3/8"-F	G1/2"-M	G1/2"-M	167.6	129	20	10	20	41	6	12	11	14	25
FST-STARR 50 HD2 G1/2-AG G3/8-IG	152	G3/8"-F	G1/2"-M	G1/2"-M	199.8	161	20	10	20	41	6	12	11	14	50
FST-STARR 75 HD2 G1/2-AG G3/8-IG	152	G3/8"-F	G1/2"-M	G1/2"-M	238.6	200	20	10	20	41	6	12	11	14	75
FST-STARR 25 HD1 G1/2-AG G3/8-IG	75	G3/8"-F	G1/2"-M	G1/2"-M	167.6	129	20	10	20	41	2	7	11	14	25
FST-STARR 50 HD1 G1/2-AG G3/8-IG	75	G3/8"-F	G1/2"-M	G1/2"-M	199.8	161	20	10	20	41	2	7	11	14	50
FST-STARR 75 HD1 G1/2-AG G3/8-IG	75	G3/8"-F	G1/2"-M	G1/2"-M	238.6	200	20	10	20	41	2	7	11	14	75
FST-STARR 25 HD2 G1/2-AG G3/8-IG	152	G3/8"-F	G1/2"-M	G1/2"-M	167.6	129	20	10	20	41	2	7	11	14	25
FST-STARR 50 HD2 G1/2-AG G3/8-IG	152	G3/8"-F	G1/2"-M	G1/2"-M	199.8	161	20	10	20	41	2	7	11	14	50
FST-STARR 75 HD2 G1/2-AG G3/8-IG	152	G3/8"-F	G1/2"-M	G1/2"-M	238.6	200	20	10	20	41	2	7	11	14	75

\*when installed, 33.5 mm higher with Flexolink; 53.0 mm higher with Flexolink in reinforced design

Type	B1 [mm]	L1 [mm]	X1 [mm]	Y1 [mm]
FLAN-PL 120x85x10 ST FLGR	120	85	90	65
FLAN-PL 160x120x10 ST SBX	160	120	120	90
FLAN-PL 400x90x10 ST SBX	400	90	280	65

# Adapters for Elbow Connector ANW

Suction cup connection from M3 to G1/2"



## Suitability for Industry Specific Applications

### Applications

- Adapter for elbow connector for use in restricted spaces
- Adapter for side connection ANW permits mounting on other accessories such as spring plungers or, together with mounting adapter VRS-AN, on standard holders or mounting brackets



Adapters for Elbow Connector ANW

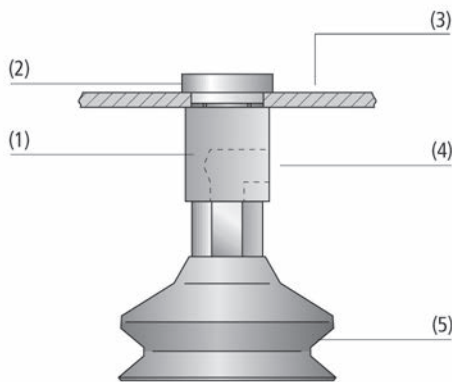

System Design Adapters for Elbow Connector ANW

### Design

- Adapter for elbow connector ANW (1) made of galvanized steel with underside connection thread for suction cups (5) and side vacuum connection (4)
- Mounting thread without vacuum connector at the top
- Mounting adapter VRS-AN (2) made of galvanized steel for screwing into further accessories or mounting to adapt for elbow connector ANW
- Connection to metal sheet (3) with a thickness of at least 3.5 mm

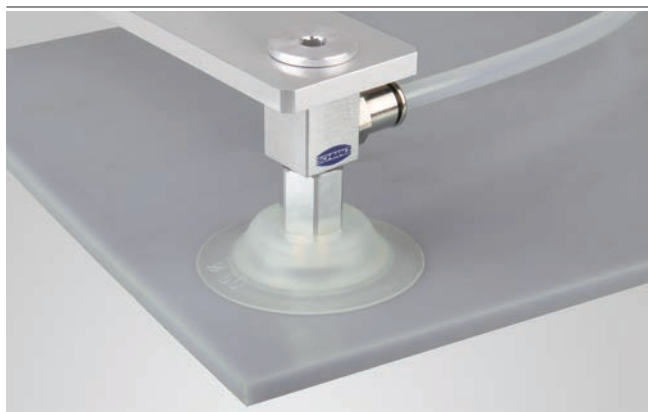

Mounting example adapters for elbow connector ANW

### Our Highlights...

- Minimal overall height
- Vacuum connector on the side
- Connection threads from M3 to G1/2"

### Your Benefits...

- Smallest possible space requirements, since suction cups can be mounted directly on cross-beams
- No additional vertical space needed
- Wide range of applications for all suction cups of the standard program

- Schmalz – The Company
- Vacuum Suction Cups
- Special Grippers
- Gripping Systems
- Clamping Systems
- Mounting Elements
- Vacuum Generators
- Valve Technology
- Switches and Monitoring
- Filters and Connections
- Services
- Contact
- Glossary
- Index of Products



# Adapters for Elbow Connector ANW

Suction cup connection from M3 to G1/2"

## Designation Code Adapters for Elbow Connector ANW



### 1 – Abbreviated designation

Code	Version
ANW	ANW

### 2 – Vacuum connection

Code	Connection
M5-IG	M5-IG (IG = female (F))
G1/8-IG	G1/8-IG
G3/8-IG	G3/8-IG

### 3 – Suction cup connection

Code	Connection
M3-IG	M3-IG (IG = female (F))
M5-IG	M5-IG
G1/8-AG	G1/8-AG (AG = male (M))
G1/4-AG	G1/4-AG
G3/8-AG	G3/8-AG
G1/2-AG	G1/2-AG

Adapter for elbow connector ANW is delivered as a ready to connect product.

Available accessories: mounting adapter VRS-AN

## Ordering Data Adapters for Elbow Connector ANW

Type	Part no.
ANW M5-IG M3-IG	10.01.01.12917
ANW M5-IG M5-IG	10.01.01.10149
ANW G1/8-IG G1/4-AG	10.01.01.10112
ANW G1/8-IG G1/8-AG	10.01.01.10113
ANW G3/8-IG G1/2-AG	10.01.01.10111
ANW G3/8-IG G3/8-AG	10.01.01.11618

## Ordering Data Accessories Adapters for Elbow Connector ANW

Type	Accessories	Part no.
ANW M5-IG M3-IG	Sealing screw with collar	VRS-AN M5-AG 10.01.01.10150
ANW M5-IG M5-IG	Sealing screw with collar	VRS-AN M5-AG 10.01.01.10150
ANW G1/8-IG G1/8-AG	Sealing screw with collar	VRS-AN G1/8-AG 10.01.01.10119
ANW G1/8-IG G1/4-AG	Sealing screw with collar	VRS-AN G1/4-AG 10.01.01.10118
ANW G3/8-IG G1/2-AG	Sealing screw with collar	VRS-AN G1/2-AG 10.01.01.10117
ANW G3/8-IG G3/8-AG	Sealing screw with collar	VRS-AN G1/2-AG 10.01.01.10117

# Adapters for Elbow Connector ANW

Suction cup connection from M3 to G1/2"



## Design Data Adapters for Elbow Connector ANW

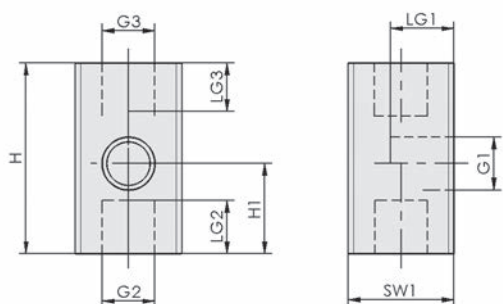

ANW M3-IG M5-IG - ANW M5-IG M5-IG

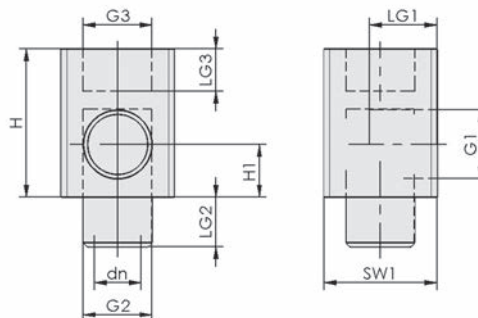

ANW G1/8-IG G1/8-AG - G3/8-IG G1/2-AG

Type	dn [mm]	G1	G2	G3	H [mm]	H1 [mm]	LG1 [mm]	LG2 [mm]	LG3 [mm]	SW1 [mm]
ANW M5-IG M3-IG	-	M5-F	M3-F	M5-F	18	8.5	6.0	5	5	10
ANW M5-IG M5-IG	-	M5-F	M5-F	M5-F	18	8.5	6.0	5	5	10
ANW G1/8-IG G1/4-AG	8.0	G1/8"-F	G1/4"-M	G1/4"-F	26	8.0	11.0	10	10	18
ANW G1/8-IG G1/8-AG	6.6	G1/8"-F	G1/8"-M	G1/8"-F	21	7.5	9.5	7	6	16
ANW G3/8-IG G1/2-AG	10.0	G3/8"-F	G1/2"-M	G1/2"-F	35	10.5	13.0	10	12	24
ANW G3/8-IG G3/8-AG	10.0	G3/8"-F	G3/8"-M	G1/2"-F	35	10.5	13.0	10	12	24

- Schmalz - The Company
- Vacuum Suction Cups
- Special Grippers
- Gripping Systems
- Clamping Systems
- Mounting Elements
- Vacuum Generators
- Valve Technology
- Switches and Monitoring
- Filters and Connections
- Services
- Contact
- Glossary
- Index of Products

Holder for Suction Cups and Spring Plungers  
**Bulkhead Connectors SVS-GE**



Suction cup connection G1/8" and G1/4"



**Suitability for Industry Specific Applications**

**Applications**

- Bulkhead connector for mounting of suction cups
- Adaptation of hose connections



Bulkhead Connectors SVS-GE

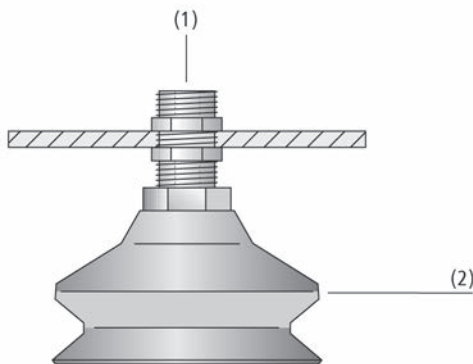

System Design Bulkhead Connectors SVS-GE



Mounting example bulkhead connectors SVS-GE

**Design**

- Stainless steel sleeve with male and female threads
- Two locking (galvanized) nuts included
- Flats for spanner on male thread
- Vacuum connection (1) by plug-in union (not included in delivery), see chapter "Filters and Connections"
- Suitable suction cups (2) can be found in section Vacuum Suction Cups

**Our Highlights...**

- Bulkhead fitting with G1/8"-IG and G1/4"-IG threads
- Male thread over the entire length
- Locking nuts included
- Stainless steel

**Your Benefits...**

- All suction cups and nipples with G1/8"-AG and G1/4"-AG threads can be screwed in
- Permits precise adjustment of the suction-cup position
- No further mounting elements needed
- No corrosion, high stability

Schmalz – The Company

Vacuum Suction Cups

Special Grippers

Gripping Systems

Clamping Systems

Mounting Elements

Vacuum Generators

Valve Technology

Switches and Monitoring

Filters and Connections

Services

Contact

Glossary

Index of Products



# Holder for Suction Cups and Spring Plungers

## Bulkhead Connectors SVS-GE



Suction cup connection G1/8" and G1/4"

### Designation Code Bulkhead Connectors SVS-GE

<b>SVS-GE</b>	-	<b>M16x1-AG</b>	-	<b>G1/8-IG</b>	-	<b>30</b>
<b>1</b>		<b>2</b>		<b>3</b>		<b>4</b>

#### 1 - Abbreviated designation

Code	Version
SVS-GE	SVS-GE

#### 2 - Male thread

Code	Thread
M16x1-AG	M16x1-AG (AG = male (M))
M20x1.5-AG	M20x1.5-AG

#### 3 - Connection

Code	Connection
G1/8-IG	G1/8-IG (IG = female (F))
G1/4-IG	G1/4-IG

#### 4 - Length

Code	Length in mm
30	30

Bulkhead connector SVS-GE is delivered as a ready-to-connect product, including two locking nuts.

### Ordering Data Bulkhead Connectors SVS-GE

Type	Part no.
SVS-GE M16x1-AG G1/8-IG 30	10.08.03.00181
SVS-GE M20x1.5-AG G1/4-IG 30	10.08.03.00180

### Design Data Bulkhead Connectors SVS-GE

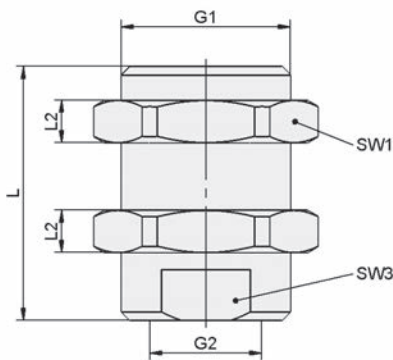

SVS-GE

Type	G1	G2	L	L2	SW1	SW3
			[mm]	[mm]	[mm]	[mm]
SVS-GE M16x1-AG G1/8-IG 30	M16x1-M	G1/8"-F	30	5	22	13
SVS-GE M20x1.5-AG G1/4-IG 30	M20x1.5-M	G1/4"-F	30	5	24	17



# Holders for Light-Metal Sections HTR-STA

Mountings for spring plungers from M5 to G1/4"



## Suitability for Industry Specific Applications

### Applications

- Holder for mounting of suction cups and spring plungers on light alloy sections

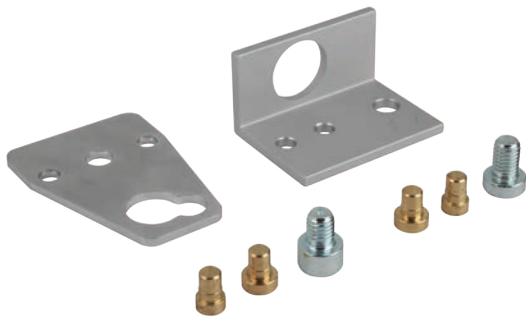

Holders for Light-Metal Sections HTR-STA

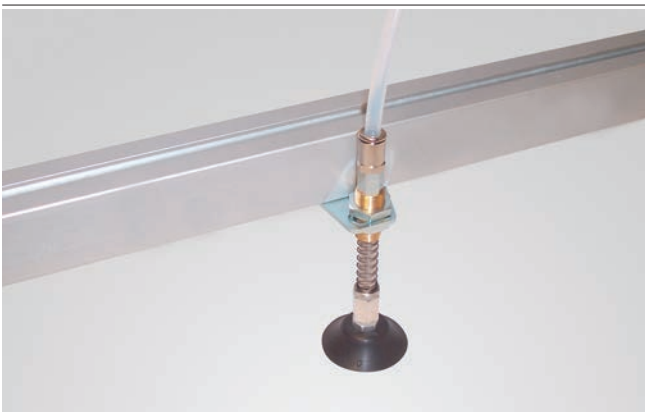

System Design Holders for Light-Metal Sections HTR-STA

### Design

- Size 47: sheet steel holder with mounting holes
- Size 55 and 62: angled aluminum bracket with mounting holes
- Delivered complete with M8 mounting screw and position locking pin



Mounting example holders HTR-STA WI

### Our Highlights...

- Sliding mounting of light metal sections with slots
- Direct mounting of suction cups and spring plungers
- Fits spring plungers of the sizes M5 to G1/4"

### Your Benefits...

- Flexible use, quick conversion, short set-up times
- For universal use
- Very versatile

# Holders for Light-Metal Sections HTR-STA

Mountings for spring plungers from M5 to G1/4"

Schmalz – The Company  
Vacuum Suction Cups  
Special Grippers  
Gripping Systems  
Clamping Systems  
Mounting Elements  
Vacuum Generators  
Valve Technology  
Switches and Monitoring  
Filters and Connections  
Services  
Contact  
Glossary  
Index of Products



## Designation Code Holders for Light-Metal Sections HTR-STA



### 1 – Abbreviated designation

Code	Version
HTR-STA	HTR-STA

### 2 – Length

Code	Length in mm
47...62	47 to 62

### 3 – Cross-beam connection

Code	Connection
1N	1 sliding block

### 4 – Spring plunger connection

Code	Diameter in mm
D10/D16..D30	ø 11/17 to 31

### 5 – Design

Code	Type
FL	Flat
WI	Angle

Holder for light metal sections HTR-STA is delivered as a ready-to-connect product including mounting screws and position locking pin.



## Ordering Data Holders for Light-Metal Sections HTR-STA

Type	Part no.
HTR-STA 47 1N D10/16 FL	10.08.03.00085
HTR-STA 55 1N D20 WI	10.08.03.00086
HTR-STA 62 1N D30 WI	10.08.03.00148



## Design Data Holders for Light-Metal Sections HTR-STA

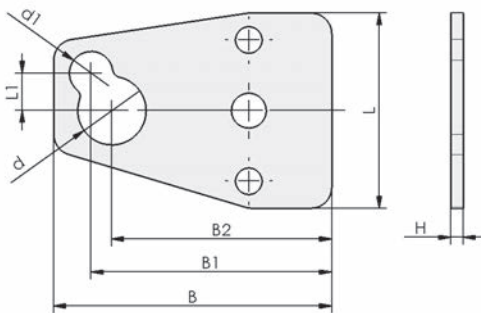

HTR-STA FL

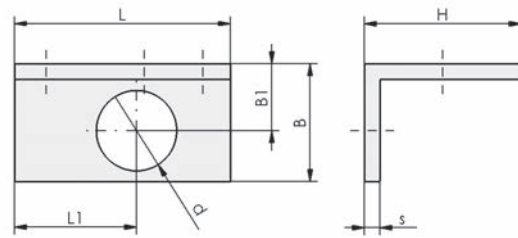

HTR-STA WI

Type	B [mm]	B1 [mm]	B2 [mm]	d [mm]	d1 [mm]	H [mm]	L [mm]	L1 [mm]	s [mm]
HTR-STA 47 1N D10/16 FL	67	58	53	17	11	3	47	9	-
HTR-STA 55 1N D20 WI	30	17	-	21	-	40	55	31	4
HTR-STA 62 1N D30 WI	50	27	-	31	-	40	62	40	5



# Holders for Square Tubes HTR-ST5

Mountings for spring plungers from M5 to G1/2"



## Suitability for Industry Specific Applications



Holders for Square Tubes HTR-ST5

## Applications

- Holder for mounting of suction cups and spring plungers on square tubes

## Design

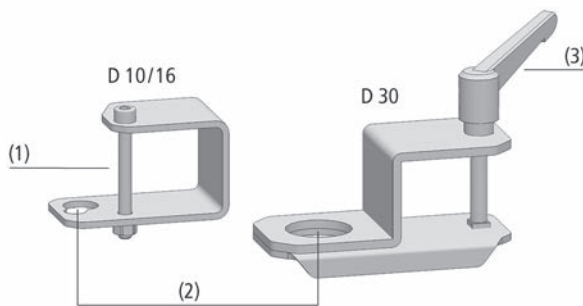

System Design Holders for Square Tubes HTR-ST5

- Folded holder made from sheet steel with drilled mounting holes (2)
- Size D10/16: secured to square tube with machine screw (1)
- Size D30: secured to square tube with clamping lever and machine screw (3)



Mounting example holders HTR-ST5

## Our Highlights...

- Sliding mounting on square tubes
- Direct mounting of suction cups and spring plungers
- Secured with clamping lever (type ST5-...-D30)
- Fits spring plungers of the sizes M5 to G1/2"

## Your Benefits...

- Flexible use, quick conversion, short set-up times
- For universal use
- Can be secured and adjusted without tools
- Very versatile



# Holders for Square Tubes HTR-ST5

Mountings for spring plungers from M5 to G1/2"

## Designation Code Holders for Square Tubes HTR-ST5

<b>HTR-ST5</b>	-	<b>30x30</b>	-	<b>D10/16</b>	-	<b>WI</b>
<b>1</b>		<b>2</b>		<b>3</b>		<b>4</b>

### 1 – Abbreviated designation

Code	Version
HTR-ST5	HTR-ST5

### 2 – For square section

Code	For square section in mm
30x30...	30x30 to 60x60
60x60	

### 3 – Spring plunger connection

Code	Diameter in mm
D10/D16...D30	ø 10.5/16.5 and 31

### 4 – Design

Code	Type
WI	Angle

Holder for square tubes HTR-ST5 is delivered as a ready-to-connect product.

Available accessories: washer with shoulder and washer

## Ordering Data Holders for Square Tubes HTR-ST5

Type	Part no.
HTR-ST5 30x30 D10/16 WI	10.08.03.00088
HTR-ST5 40x40 D10/16 WI	10.08.03.00089
HTR-ST5 40x40 D30 WI	10.08.03.00090
HTR-ST5 50x50 D30 WI	10.08.03.00091
HTR-ST5 60x60 D30 WI	10.08.03.00092

## Ordering Data Accessories Holders for Square Tubes HTR-ST5

Type	Washer with shoulder M16	Washer with shoulder M18	Washer with shoulder M20	Washer M30
HTR-ST5 30x30 D10/16 WI	10.01.01.10025	10.01.03.06140	10.01.01.10015	20.06.01.00044
HTR-ST5 40x40 D10/16 WI	10.01.01.10025	10.01.03.06140	10.01.01.10015	20.06.01.00044
HTR-ST5 40x40 D30 WI	10.01.01.10025	10.01.03.06140	10.01.01.10015	20.06.01.00044
HTR-ST5 50x50 D30 WI	10.01.01.10025	10.01.03.06140	10.01.01.10015	20.06.01.00044
HTR-ST5 60x60 D30 WI	10.01.01.10025	10.01.03.06140	10.01.01.10015	20.06.01.00044

# Holders for Square Tubes HTR-ST5

Mountings for spring plungers from M5 to G1/2"



## Design Data Holders for Square Tubes HTR-ST5

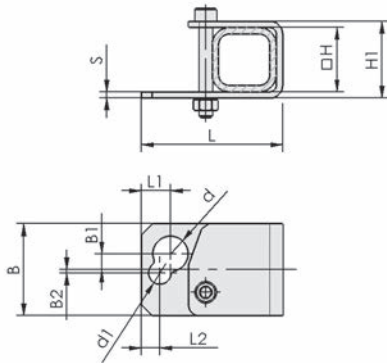

HTR-ST5 D10/16

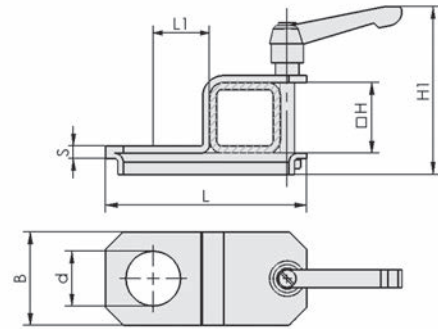

HTR-ST5 D30

Type	B [mm]	B1 [mm]	B2 [mm]	d [mm]	d1 [mm]	H [mm]	H1 [mm]	L [mm]	L1 [mm]	L2 [mm]	s [mm]
HTR-ST5 30x30 D10/16 WI	43	7.5	1.5	16.5	10.5	30	36	66	11	8.5	3
HTR-ST5 40x40 D10/16 WI	43	7.5	1.5	16.5	10.5	40	46	76	11	8.5	3
HTR-ST5 40x40 D30 WI	53	-	-	31.0	-	40	95	114	32	-	7
HTR-ST5 50x50 D30 WI	53	-	-	31.0	-	50	105	124	32	-	7
HTR-ST5 60x60 D30 WI	53	-	-	31.0	-	60	115	134	32	-	7

Schmalz – The Company  
 Vacuum Suction Cups  
 Special Grippers  
 Gripping Systems  
 Clamping Systems  
 Mounting Elements  
 Vacuum Generators  
 Valve Technology  
 Switches and Monitoring  
 Filters and Connections  
 Services  
 Contact  
 Glossary  
 Index of Products



# Universal Holders HTR-UNI

Connection G1/4"



Universal Holders HTR-UNI

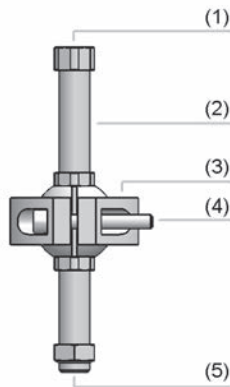

System Design Universal Holders HTR-UNI



Suction cups with universal holders HTR-UNI for handling sheet metal

## Suitability for Industry Specific Applications

### Applications

- Universal holder for mounting of vacuum components on existing cross beams made of square or round tubes with the aid of various adapters
- Adjustable height and inclination for flexible adaptation to workpieces

### Design

- Holder made of high strength, anodized aluminum, consisting of holder tube (2), ball clamp (3) and various adapters for mounting of square and round tubes
- Threaded tube (5) has a G1/4" thread at the bottom for a suction cup and a G1/4" thread at the top (1) for connection of a vacuum line or an inline ejector
- Including securing screws (4)

### Our Highlights...

- Adjustment and fixing with ball clamp
- Adjustable height and inclination
- Suitable for mounting on square and round tubes
- Suction cups can be screwed directly into the G1/4" thread

### Your Benefits...

- Flexible use, rapid changing, short set-up times
- Flexible adaptation to workpieces with, e.g. curved sheet metal
- For universal use
- Quick and efficient construction of a load cross beam

- Schmalz – The Company
- Vacuum Suction Cups
- Special Grippers
- Gripping Systems
- Clamping Systems
- Mounting Elements
- Vacuum Generators
- Valve Technology
- Switches and Monitoring
- Filters and Connections
- Services
- Contact
- Glossary
- Index of Products



# Holder for Suction Cups and Spring Plungers

## Universal Holders HTR-UNI



Connection G1/4"



### Designation Code Universal Holders HTR-UNI

<b>HTR-UNI</b>	-	<b>1N</b>	-	<b>G2</b>	-	<b>80</b>
1		2		3		4

#### 1 – Abbreviated designation

Code	Version
HTR-UNI	HTR-UNI

#### 2 – Cross-beam connection

Code	Connection
1N	1 sliding block
2N	2 sliding blocks

#### 3 – Connection

Code	Connection
G2	Connection thread G1/4-AG

#### 4 – Length

Code	Length in mm
80...200	80 to 200

Holder HTR-UNI is delivered unassembled. The delivery consists of:

- Holder tube – available in various lengths
- Ball clamp – available in various versions

Available accessories: section adapter, tube adapter, tube adapter reducing set, suction cup connection



### Ordering Data Universal Holders HTR-UNI

Type	Part no.
HTR-UNI 1N G2 80	10.01.03.00107
HTR-UNI 2N G2 80	10.01.03.00223
HTR-UNI 2N G2 80	10.01.03.00298
HTR-UNI 2N G2 110	10.01.03.00328
HTR-UNI 2N G2 140	10.01.03.00299
HTR-UNI 2N G2 200	10.01.03.00309



### Ordering Data Accessories Universal Holders HTR-UNI

Type		Part no.
Section adapter	HTR-STB 30x30 UNI	10.01.03.00135
Tube adapter	HTR-STC D32 UNI	10.01.03.00108
Tube adapter reducing set	BUCHSE 32-25x21 PA	10.01.03.00097
Suction cup connection	SAUG-ANB G1/4-AG 80	10.01.03.00292
Suction cup connection	SAUG-ANB G1/4-AG 110	10.01.03.00327
Suction cup connection	SAUG-ANB G1/4-AG 140	10.01.03.00291
Suction cup connection	SAUG-ANB G1/4-AG 200	10.01.03.00308

Schmalz –  
The Company

Vacuum  
Suction Cups

Special  
Grippers

Gripping  
Systems

Clamping  
Systems

Mounting  
Elements

Vacuum  
Generators

Valve  
Technology

Switches and  
Monitoring

Filters and  
Connections

Services

Contact

Glossary

Index of  
Products



# Universal Holders HTR-UNI

Connection G1/4"



## Design Data Universal Holders HTR-UNI

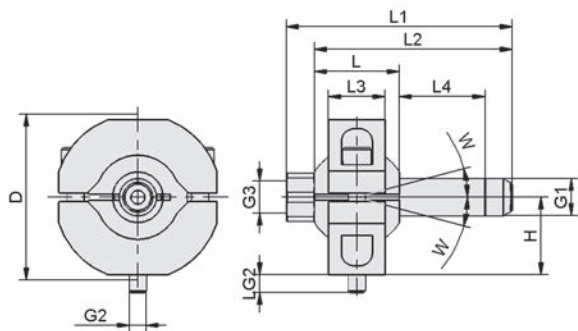

HTR-UNI 1N G2

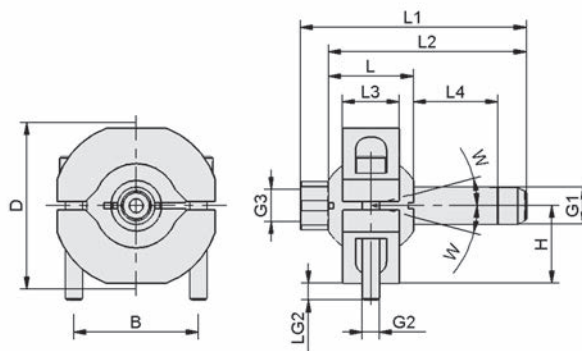

HTR-UNI 2N G2

Type	B [mm]	D [mm]	G1	G2	G3	H [mm]	L [mm]	L1 [mm]	L2 [mm]	L3 [mm]	L4 [mm]	LG2 [mm]	W [°]
HTR-UNI 1N G2 80	-	59	G1/4"-M	M6-M	G1/4"-F	27.5	30	80	70	20	25	7	15
HTR-UNI 2N G2 80	44	59	G1/4"-M	M6-M	G1/4"-F	27.5	30	80	70	20	25	6	15
HTR-UNI 2N G2 80	44	59	G1/4"-M	M6-M	G1/4"-F	27.5	30	80	70	20	6	6	15
HTR-UNI 2N G2 110	44	59	G1/4"-M	M6-M	G1/4"-F	27.5	30	110	100	20	36	6	15
HTR-UNI 2N G2 140	44	59	G1/4"-M	M6-M	G1/4"-F	27.5	30	140	130	20	66	6	15
HTR-UNI 2N G2 200	44	59	G1/4"-M	M6-M	G1/4"-F	27.5	30	200	190	20	126	6	15



- Schmalz - The Company
- Vacuum Suction Cups
- Special Grippers
- Gripping Systems
- Clamping Systems
- Mounting Elements
- Vacuum Generators
- Valve Technology
- Switches and Monitoring
- Filters and Connections
- Services
- Contact
- Glossary
- Index of Products



# Mounting Sections MO-PROF

Cross-sections 40 x 40 mm and 80 x 40 mm



Mounting Sections MO-PROF

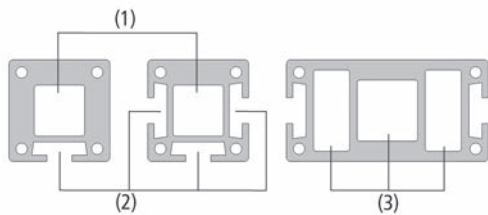

System Design Mounting Sections MO-PROF

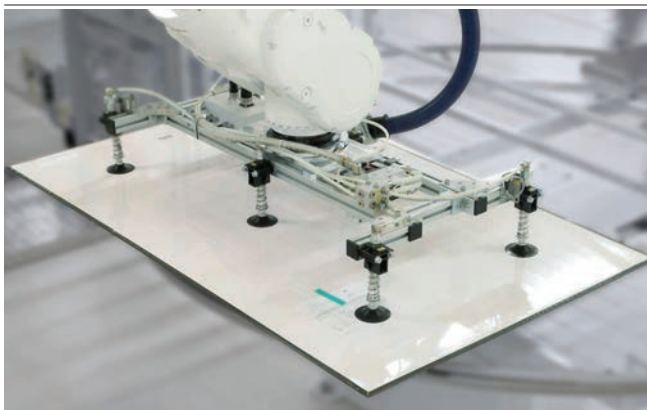

Mounting example mounting sections MO-PROF

## Suitability for Industry Specific Applications

### Applications

- Mounting section for flexible construction of tailor made load cross-beams
- Used as load cross beam and vacuum distributor
- Three chamber section permits distribution of different vacuum and compressed air pressures

### Design

- Hollow extruded aluminum sections
- 40 x 40 mm section with one chamber (1) and optionally with one or three slots on the sides (2)
- 80 x 40 mm section with three chambers (3) and two slots on the sides
- Holes and grooves at the ends for assembly with the aid of elbow and corner connectors, sealing plates and other accessories

### Our Highlights...

- Vacuum tight hollow section with internal chambers
- Suction cups can be screwed directly into the sections
- Sections with slots at the sides
- High strength extruded aluminum sections

### Your Benefits...

- Vacuum / compressed air can be carried directly in the sections
- Hose-free, integrated vacuum distribution from a central connection to the individual suction cups
- Simple attachment of mounting elements such as holders and plungers
- Low weight combined with high load capacity and maximum precision

Schmalz – The Company

Vacuum Suction Cups

Special Grippers

Gripping Systems

Clamping Systems

Mounting Elements

Vacuum Generators

Valve Technology

Switches and Monitoring

Filters and Connections

Services

Contact

Glossary

Index of Products



# Mounting Sections MO-PROF

Cross-sections 40 x 40 mm and 80 x 40 mm

## Designation Code Mounting Sections MO-PROF



### 1 - Abbreviated designation

Code	Version
MO-PROF	MO-PROF

### 2 - Dimensions

Code	Dimensions in mm
40...80x40	40 and 80x40

### 3 - Design

Code	Type
1TN	1 groove
2TN	2 grooves
3TN	3 grooves

### 4 - Material

Code	Material
AL-1	Aluminum

Mounting sections MO-PROF is delivered in the desired length.

Available accessories: sealing plate, sealing frame, section connector, mounting bracket, sliding block, drilling jig, self-cutting lens head screws

## Ordering Data Mounting Sections MO-PROF

Type	Part no.
MO-PROF 40 1TN AL-1	26.07.01.00023
MO-PROF 40 3TN AL-1	26.07.01.00022
MO-PROF 80x40 2TN AL-1	26.07.01.00021

## Ordering Data Accessories Mounting Sections MO-PROF

Type		Part no.
Sealing plate	VRS-PL-40 MO-PROF	25.09.06.00008
Sealing plate	VRS-PL-40 MO-PROF	25.09.06.00026
Sealing plate	VRS-PL-40 G1/2-IG MO-PROF	25.09.06.00009
Sealing plate	VRS-PL-80x40 MO-PROF	25.09.06.00001
Sealing plate	VRS-PL-80x40 G1/2-IG MO-PROF	25.09.06.00010
Sealing frame	DI-RA 40 PPTA	10.07.08.00131
Sealing frame	DI-RA 80x40 PPTA	10.07.08.00132
Section connector	VBR-PR 40x55x55 E-V	10.08.03.00099
Section connector	VBR-PR 185x185x3 K-FL	25.09.06.00005
Section connector	VBR-PR 150x3 E-FL	25.09.06.00006
Mounting bracket	BEF-WIN 40x40x40 5 MO-PROF	25.09.06.00007
Drilling template	BOHR-SCHAB MO-PROF 50x50-1N	10.08.03.00100
Sliding block	NUT-STEI 10x20 M6-IG	25.09.06.00002
Sliding block	NUT-STEI 10x20 M8-IG	25.09.06.00003
Sliding block	NUT-STEI 20 M8-IG 10	25.09.06.00012
Self-cutting lens head screw	SCHR WN1552 5x20 ST VZ T25	20.10.03.00008

Schmalz - The Company  
Vacuum Suction Cups  
Special Grippers  
Gripping Systems  
Clamping Systems  
Mounting Elements  
Vacuum Generators  
Valve Technology  
Switches and Monitoring  
Filters and Connections  
Services  
Contact  
Glossary  
Index of Products

# Mounting Sections MO-PROF

Cross-sections 40 x 40 mm and 80 x 40 mm



## Technical Data Mounting Sections MO-PROF

Type	Area [cm <sup>2</sup> ]	Resistance moment Wx [cm <sup>3</sup> ]	Resistance moment Wy [cm <sup>3</sup> ]	Moment of area Ix [cm]	Moment of area Iy [cm]	Mass [kg/m]	Warping (max.) [mm/m]	Length (max.) [mm]
MO-PROF 40 1TN AL-1	9.1	6.9	9.6	13.7	17.0	2.5	0.8	6,000
MO-PROF 40 3TN AL-1	6.5	5.5	5.2	12.7	10.4	1.8	0.8	6,000
MO-PROF 80x40 2TN AL-1	12.1	14.0	19.3	28.1	77.2	3.3	0.8	6,000



## Design Data Mounting Sections MO-PROF

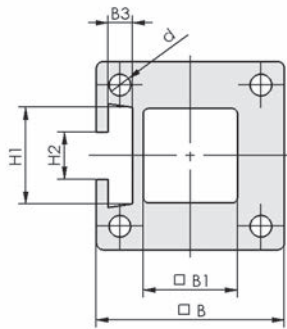

MO-PROF 40 1TN

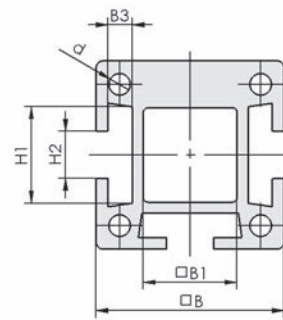

MO-PROF 40 3TN

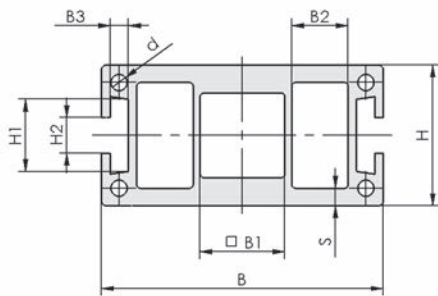

MO-PROF 80x40 2TN

Type	B [mm]	B1 [mm]	B2 [mm]	B3 [mm]	d [mm]	H [mm]	H1 [mm]	H2 [mm]	s [mm]
MO-PROF 40 1TN AL-1	40	20	-	5.2	4.6	-	20.5	10	-
MO-PROF 40 3TN AL-1	40	20	-	5.2	4.6	-	20.5	10	-
MO-PROF 80x40 2TN AL-1	80	24	14.3	5.2	4.6	40	20.5	10	4

# Vacuum Generators



Schmalz – The Company
Vacuum Suction Cups
Special Grippers
Gripping Systems
Clamping Systems
Mounting Elements
<b>Vacuum Generators</b>
Valve Technology
Switches and Monitoring
Filters and Connections
Services
Contact
Glossary
Index of Products

# Overview of Section

At a Glance

Selection Aid		Page	
	<b>Selection by Suction Capacity</b>	418	Gripping Systems
<b>Ejector Modules</b>			Clamping Systems
	<b>Ejector Modules ecoPump SEP</b> <ul style="list-style-type: none"> <li>Suction rate up to 309 l/min</li> <li>For airtight or porous workpieces</li> </ul>	421	Mounting Elements
	<p>PACKAGING</p> <p>Efficient ejector with eco nozzle technology for space-saving installation directly on the suction cup or as an insert nozzle.</p>		Vacuum Generators
<b>Basic Ejectors</b>			Valve Technology
	<b>Basic Ejectors SBPL</b> <ul style="list-style-type: none"> <li>Suction capacity: 290 to 1,140 l/min</li> <li>Max. vacuum: 61 to 90 %</li> <li>Body made of plastics</li> </ul>	427	Switches and Monitoring
	<p>WOOD    PACKAGING    GLASS    COMPOSITE</p> <p>Basic ejector equipped with eco nozzle; extremely high suction rate for airtight or porous workpieces, especially in systems with central vacuum generation.</p>		Filters and Connections
	<b>Basic Ejectors SEG</b> <ul style="list-style-type: none"> <li>Suction capacity up to 370 l/min</li> <li>Max. vacuum: 85 %</li> <li>Body made of anodized aluminum</li> </ul>	435	Services
	<p>UNIVERSAL</p> <p>Robust basic ejector with aluminum basic body for universal use, especially in systems with decentralized vacuum generation.</p>		Contact
	<b>Basic Ejectors SBP</b> <ul style="list-style-type: none"> <li>Suction capacity up to 215 l/min</li> <li>Max. vacuum: 85 %</li> <li>Plastic housing</li> </ul>	441	Glossary
	<p>UNIVERSAL</p> <p>Compact basic ejector with plastic body for high-speed handling of suction-tight workpieces.</p>		Index of Products

# Overview of Section

## At a Glance

Schmalz – The Company  
 Vacuum Suction Cups  
 Special Grippers  
 Gripping Systems  
 Clamping Systems  
 Mounting Elements  
 Vacuum Generators  
 Valve Technology  
 Switches and Monitoring  
 Filters and Connections  
 Services  
 Contact  
 Glossary  
 Index of Products

Page

446



### Basic Ejectors SBP-C with Additional Functions

- Suction capacity up to 215 l/min
- Max. vacuum: 85 %
- Body made of plastic
- Integrated valve technology



Basic ejector with plastic body, integrated valve technology and vacuum switch for optimal cycle times.

454



### Basic Ejectors SBP-HV/HF

- Suction rate up to 309 l/min
- For airtight or porous workpieces



Efficient basic ejector with eco nozzle technology for installation directly at the suction cup.

## Inline Ejectors

460



### Inline Ejectors SLP

- Suction capacity up to 16 l/min
- Max. vacuum: 85 %
- Body made of plastic



Lightweight, compact inline ejector with plastic body for space-saving, decentralized vacuum generation directly in the hose line.

464



### Inline Ejectors VR

- Suction capacity up to 24 l/min
- Max. vacuum: 85 %
- Body made of aluminum



Robust inline ejector with aluminum body for space-saving decentralized vacuum generation and mounting directly on the suction cup.

## Decentralized Ejectors

468



### Ejectors with Active Blow Off SEAC

- Suction capacity up to 35 l/min
- Max. vacuum: 85 %
- Body made of plastic



Ejector with plastic body and integrated active blow off function using compressed air; built in minimum size and weight.

472



### Ejectors with Blow Off System SEAC RP

- Suction capacity up to 35 l/min
- Max. vacuum: 85 %



Ejector with integrated pneumatic air-saving regulation as well as active blow off using compressed air; built in minimum size.

476



### Ejectors with Atmospheric Ventilation SEAC ECO

- Suction capacity up to 35 l/min
- Max. vacuum: 85 %
- With atmospheric ventilation



Ejector with anodized aluminum body and integrated atmospheric ventilation for lowest possible operating costs; built in minimum size.

# Overview of Section

At a Glance

## Compact Ejectors

			Page	
	<p><b>Compact Ejectors SCPSb</b></p> <ul style="list-style-type: none"> <li>• Suction capacity up to 67 l/min</li> <li>• Max. vacuum: 85 %</li> <li>• Body made of plastic</li> </ul>	 <p>Small compact ejector with efficient eco nozzle technology for processes in confined spaces.</p>	480	Schmalz – The Company Vacuum Suction Cups
	<p><b>Compact Ejectors SCPS / SCPSi</b></p> <ul style="list-style-type: none"> <li>• Suction capacity up to 67 l/min</li> <li>• Max. vacuum: 85 %</li> <li>• Body made of plastic</li> </ul>	 <p>Small compact ejector with efficient eco nozzle technology, optional IO-Link interface. For use in dynamic processes in confined spaces.</p>	486	Special Grippers Gripping Systems
	<p><b>Compact Ejectors X-Pump SXPi / SXMPi with IO-Link</b></p> <ul style="list-style-type: none"> <li>• Suction capacity up to 220 l/min</li> <li>• Max. vacuum: 85 %</li> <li>• Body made of plastic</li> </ul>	 <p>High end compact ejector with IO-Link interface, pressure monitoring, air-saving function for energy and process control.</p>	492	Clamping Systems Mounting Elements
	<p><b>Compact Ejectors SCPi / SMPi</b></p> <ul style="list-style-type: none"> <li>• Suction capacity up to 195 l/min</li> <li>• Max. vacuum: 85 %</li> </ul>	 <p>Compact ejector with integrated system monitoring, IO-Link, air-saving regulation and optional power blow off for highly dynamic, efficient processes.</p>	497	Vacuum Generators
	<p><b>Compact Ejectors SCPM</b></p> <ul style="list-style-type: none"> <li>• Suction capacity 6 to 23 l/min</li> <li>• Max. vacuum: 85 %</li> <li>• Body made of aluminum</li> </ul>	 <p>Compact ejector with optional system monitoring and optional air-saving regulation for dynamic processes in tight spaces.</p>	502	Valve Technology Switches and Monitoring
	<p><b>Compact Ejectors SEM-C</b></p> <ul style="list-style-type: none"> <li>• Suction capacity up to 673 l/min</li> <li>• Max. vacuum: 85 %</li> <li>• Body made of aluminum</li> <li>• Multi-stage nozzle system</li> </ul>	   <p>Compact ejector with high suction rate and integrated system monitoring for handling of porous workpieces.</p>	506	Filters and Connections Services
	<p><b>Compact Terminal SCTMi</b></p> <ul style="list-style-type: none"> <li>• Suction capacity up to 67 l/min per disc</li> <li>• Max. vacuum: 85 %</li> <li>• Body made of plastic</li> </ul>	 <p>Compact terminal consisting of 2 to 16 compact ejectors with eco nozzle technology, air-saving function, energy and process control and IO-Link interface.</p>	512	Contact Glossary

## Compact Terminal

# Overview of Section

At a Glance

## Vacuum Pumps

			Page	
Schmalz – The Company				
Vacuum Suction Cups		<p><b>Dry-Running Vacuum Pumps EVE-TR</b></p> <ul style="list-style-type: none"> <li>Suction capacity up to 244 m<sup>3</sup>/h</li> <li>Max. vacuum: 92 %</li> </ul>	 UNIVERSAL Oil free vacuum pump with integrated fan, permanently lubricated bearings and high efficiency for handling of airtight parts.	518
Special Grippers				
Gripping Systems		<p><b>Dry-Running Vacuum Pumps EVE-TR X</b></p> <ul style="list-style-type: none"> <li>Suction rate: 10 to 129 m<sup>3</sup>/h</li> <li>Max. vacuum: 92 %</li> </ul>	 UNIVERSAL Oil free vacuum pump with significantly longer maintenance intervals and high efficiency for handling airtight parts.	526
Clamping Systems				
Mounting Elements		<p><b>Oil-Lubricated Vacuum Pumps EVE-OG</b></p> <ul style="list-style-type: none"> <li>Suction capacity up to 255 m<sup>3</sup>/h</li> <li>Max. vacuum: 98 %</li> </ul>	 UNIVERSAL Low-maintenance, oil-lubricated vacuum pump with oil separator, three-phase current drive for handling of airtight parts.	527
Vacuum Generators				
Valve Technology		<p><b>Vacuum Reservoirs VOL</b></p> <ul style="list-style-type: none"> <li>Capacities: 5 to 200 l</li> </ul>	 UNIVERSAL Vacuum reservoir with non-return valve, manometer and dust filter for maintaining vacuum in case of power failure.	533
Switches and Monitoring		<p><b>Vacuum Centres VZ</b></p> <ul style="list-style-type: none"> <li>Suction capacity up to 165 m<sup>3</sup>/h</li> <li>Max. vacuum: 98 %</li> <li>Reservoir capacity up to 200 l</li> </ul>	 UNIVERSAL Vacuum center with pump, vacuum reservoir and non-return valve as a complete product.	534
Filters and Connections				
Services				
	<h2>Vacuum Blowers</h2>			
		<p><b>Vacuum Blowers SGBL-DG</b></p> <ul style="list-style-type: none"> <li>Suction capacity up to 540 m<sup>3</sup>/h</li> <li>Max. vacuum: 46 %</li> </ul>	 PACKAGING  WOOD  COMPOSITE Vacuum blower for handling of extremely porous workpieces with maximum flow rate.	535
Contact				
Glossary		<p><b>Vacuum Blowers SB</b></p> <ul style="list-style-type: none"> <li>Suction rate: 75 to 1,250 m<sup>3</sup>/h</li> <li>Max. vacuum: 40 %</li> </ul>	 UNIVERSAL Vacuum blower for handling extremely porous workpieces with maximum flow rate.	541
Index of Products				



# Overview of Section

At a Glance

## Electrical Vacuum Generators

Page



### Vacuum Generator ECBPi

- Suction capacity up to 12 l/min
- Max. vacuum: 75 %



Intelligent, autonomous and flexible vacuum generation. For use in mobile robotics applications.

549

## Vacuum Generators for CNC Machining Centers



### Vacuum Unit VAGG

- Mobile vacuum generation and monitoring
- Suction capacities of 6, 18, 40 and 63 m<sup>3</sup>/h

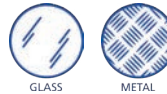

Mobile vacuum supply for wet machining in CNC machining centers.

552



### Vacuum Operation Center VOC

- Central vacuum generation and monitoring
- Suction capacities of 40, 63, 100 and 250 m<sup>3</sup>/h

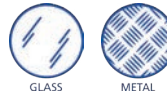

Stationary vacuum supply for wet machining in CNC machining centers with automatic liquid condenser.

555

Schmalz – The Company

Vacuum Suction Cups

Special Grippers

Gripping Systems

Clamping Systems

Mounting Elements

Vacuum Generators

Valve Technology

Switches and Monitoring

Filters and Connections

Services

Contact

Glossary

Index of Products

	Schmalz – The Company	Vacuum Suction Cups	Special Grippers	Suction rate [l/min]	Nozzle size [mm]	Technical data												
						Max. vacuum [%]	Operating pressure [bar]	Operating temperature [°C]	Weight [g]									
				1 – 10	11 – 100	101 – 500	501 – 1,000	1,001 – 5,000	5,001 – 10,0000	0 – 0.5	0.5 – 1	1 – 2	2 – 3	3 – 4				
<b>Ejector modules</b>																		
Gripping Systems					13 – 309						0.3 – 1.6				60/91	3 – 5	0 – 60	0.8 – 22.8
<b>Basic ejectors</b>																		
Gripping Systems					7 – 370						0.5 – 3				55/85	3 – 6	-10 – 80	10 – 404
Clamping Systems					8 – 215						0.5 – 2.5				85	3 – 6	0 – 60	7.5 – 50
Clamping Systems					8 – 215						0.5 – 2.5				85	3 – 6	0 – 60	87 – 143
Clamping Systems					13 – 309						0.3 – 1.6				60/91	3 – 5	0 – 60	29 – 295
Mounting Elements						290 – 1,140						1.3 – 1.5 <sup>1)</sup>			60/91	3 – 5	0 – 60	750 – 1,500
<b>Inline ejectors</b>																		
Vacuum Generators					8 – 16						0.5 – 0.7				85	3 – 6	0 – 60	5
Vacuum Generators					7 – 21						0.5 – 0.9				87/90	3 – 6	0 – 60	15
<b>Decentralized ejectors</b>																		
Valve Technology					35						1.0				85	3 – 6	0 – 50	62 – 157
Valve Technology					35						1.0				85	3 – 6	0 – 50	180
Valve Technology					35						1.0				85	4 – 6	0 – 60	95
<b>Feed ejectors</b>																		
Switches and Monitoring					6 – 23						0.5 – 1.0				85	3 – 6	0 – 45	80
Filters and Connections					16 – 67						0.7 – 1.5				85	2 – 6	0 – 50	195
Filters and Connections					16 – 67						0.7 – 1.5				85	2 – 6	0 – 50	165
Filters and Connections					16 – 67						0.7 – 1.5				85	2 – 6	0 – 50	195
Services					75 – 195						1.5 – 2.5				85	4 – 7	0 – 50	560
Services					185 – 220						2.5 – 3.0				85	4 – 7	0 – 50	770 – 910
Services						338 – 673					1.3 <sup>2)</sup>				81 – 87	4 – 6	0 – 50	1,600 – 2,200
<b>Compact ejectors</b>																		
Contact					12										75	–	5 – 45	775
Contact					215 – 8,640										92	–	0 – 45	2.4 – 250 (kg)
Glossary					166 – 4,250										98	–	-20 – 210	19 – 195 (kg)
Glossary					1,300 – 9,000										11 – 46	–	0 – 40	11 – 1,125 (kg)
Index of Products					1,250 – 20,000										11 – 41	–	0 – 40	13 – 125 (kg)

<sup>1)</sup> The SBPL ejector can be expanded with up to 6 nozzles on a modular basis  
<sup>2)</sup> The SEM-C ejector can be expanded with up to 4 nozzles on a modular basis



- Schmalz – The Company
- Vacuum Suction Cups
- Special Grippers
- Gripping Systems
- Clamping Systems
- Mounting Elements
- Vacuum Generators**
- Valve Technology
- Switches and Monitoring
- Filters and Connections
- Services
- Contact
- Glossary
- Index of Products

**Explanatory Information About the Vacuum Generator Selection Matrix**



**IO-Link interface**

- IO-Link provides bidirectional communication with all current field-bus systems
- Recorded condition data can be viewed and used up to control level
- IO-Link supports remote parameterization and remote diagnostics



**NFC interface**

- Analysis and accessibility – via app the devices can directly be read out and parameterized from a smartphone



**Automatic air saving function**

- 80 % reduction of compressed air consumption
- Switches off the suction function once a safe vacuum value has been reached until the next cycle or until the vacuum falls below the safe vacuum value
- No electrical signals are required for the pneumatically operated air-saving function



**Power blow off**

- Integrated power blow off module for maximum blow off volume flow

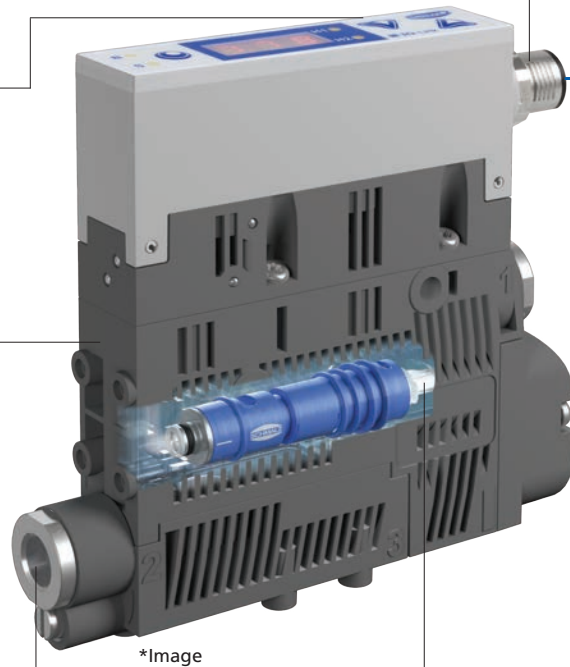

**Condition monitoring**

- Condition monitoring to increase system availability based on a detailed condition analysis and early fault recognition



**Predictive maintenance**

- Predictive maintenance to increase the performance of gripping systems
- Quick and easy system optimization through evaluation of gripping system performance



**Energy monitoring**

- Energy monitoring to optimize vacuum system energy consumption
- Identification of disproportionate energy consumption



**Eco-nozzle technology**

- The eco nozzle technology provides a considerably higher suction rate with minimal compressed air consumption, permitting energy efficient vacuum generation

\* The compact ejector SCPSi shown here is used to illustrate all of the important vacuum generator functions in a schematic diagram. Please note that not all of the functions provided in the SCPSi are shown.

# Ejector Modules ecoPump SEP

Suction rate up to 309 l/min



Ejector Modules ecoPump SEP

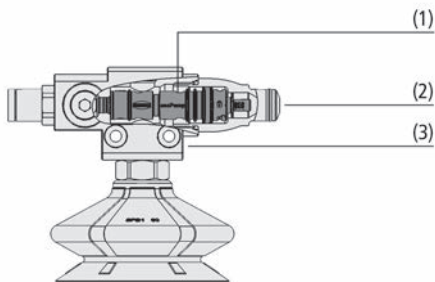

System Design Ejector Modules ecoPump SEP



Vacuum generation by ejector modules SEP for handling ampoules

## Suitability for Industry Specific Applications

### Applications

- Ejector module for energy efficient vacuum generation with Schmalz eco nozzle technology
- Direct installation in gripping tools without separate housing
- Integration of the vacuum generation as close as possible to the suction cup
- For use in the packaging industry, e.g. in carton erectors or multi-circuit systems

### Design

- Compact, lightweight plastic ejector nozzle (1)
- Available in three performance classes and two versions with optimized air consumption for airtight (HV) or porous (HF) materials
- Available with optional holder cap SHC (2) for fixation of the ejector nozzle, alternatively with silencer SD or with ecoPump housing SFE (3)

### Our Highlights...

- High suction capacity with low air consumption
- Use for airtight (HV) and porous (HF) workpieces
- Fast, with powerful vacuum
- Resistant to dirt

### Your Benefits...

- Energy efficient vacuum generation
- Fast and reliable product selection for each application
- Quickly reaches working vacuum; reliable compensation for leakages
- Long service intervals, as well as simple, tool free cleaning

- Schmalz – The Company
- Vacuum Suction Cups
- Special Grippers
- Gripping Systems
- Clamping Systems
- Mounting Elements
- Vacuum Generators
- Valve Technology
- Switches and Monitoring
- Filters and Connections
- Services
- Contact
- Glossary
- Index of Products



# Ejector Modules ecoPump SEP

Suction rate up to 309 l/min

## Selection Aid

	Step 1 Define the area of application	Step 2 Define the distance from the suction point	Step 3 Select the performance class		Step 4 Air-saving function can be implemented*	Product Recommendation Type Part no. / Illustration
			Max. suction capacity [l/min]	Max. vacuum [mbar]		
Special Grippers	Porous workpieces E.g. cardboard, non-rigid bags, particle boards → High-flow version (HF) with high suction flow rate	Close to the suction cup Short hose lines with low air volume → Two-stage nozzle	15	550	no	SEP-HF-2-03-07 10.02.01.01341 ①
			42	700	no	SEP-HF-2-06-13 10.02.01.01343 ②
			175	610	no	SEP-HF-2-13-22 10.02.01.01347 ③
		Far away from the suction cup Long hose lines with high air volume → Three-stage nozzle	67	700	no	SEP-HF-3-06-13 10.02.01.01344 ④
			298	610	no	SEP-HF-3-13-22 10.02.01.01348 ⑤
			Airtight workpieces E.g. ampules, syringes and vials, plastic injection-molded parts, sheet metal parts → High-vacuum version (HV) with high vacuum level	Close to the suction cup Short hose lines with low air volume → Two-stage nozzle	13	790
42	850	no			SEP-HV-2-07-13 10.02.01.01394 ⑦	
		yes			SEP-HV-2-07-13-S 10.02.01.01406 ⑧	
153	900	no		SEP-HV-2-16-22 10.02.01.01396 ⑨		
		yes		SEP-HV-2-16-22-S 10.02.01.01410 ⑩		
Far away from the suction cup Long hose lines with high air volume → Three-stage nozzle	77	850		no	SEP-HV-3-07-13 10.02.01.01395 ⑪	
				yes	SEP-HV-3-07-13-S 10.02.01.01407 ⑫	
	309	900		no	SEP-HV-3-16-22 10.02.01.01397 ⑬	
yes	SEP-HV-3-16-22-S 10.02.01.01411 ⑭					

\*Maintenance of the vacuum for airtight workpieces using additional safety non-return valve. An active blow off pulse is required to release the workpiece.

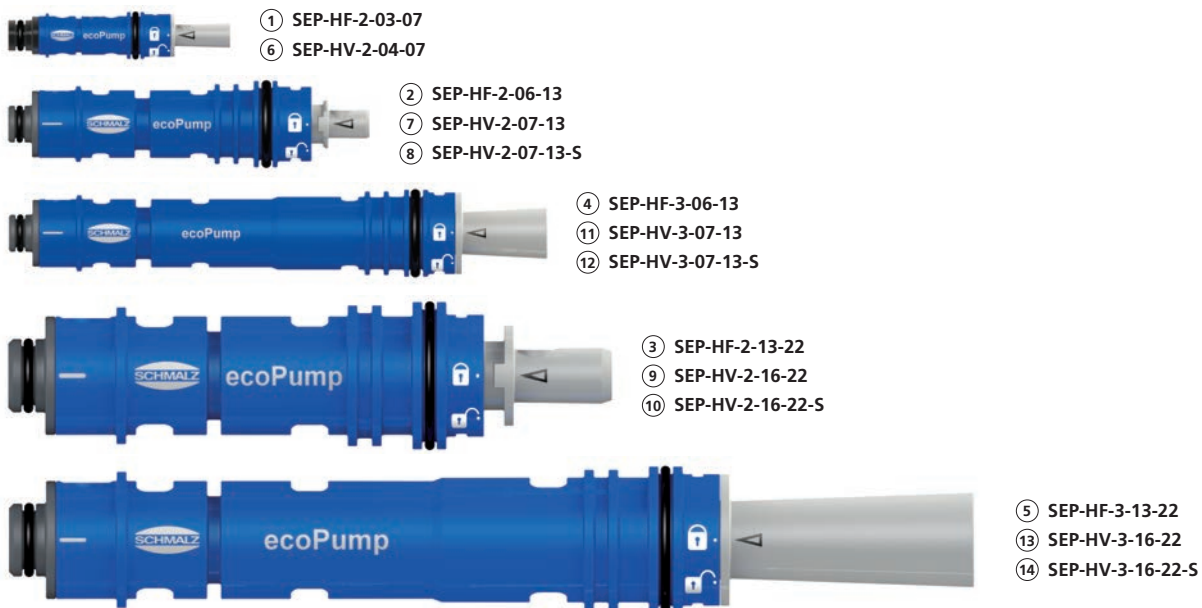

Illustrations in original size

# Ejector Modules ecoPump SEP

Suction rate up to 309 l/min



## Designation Code Ejector Modules ecoPump SEP

<b>SEP</b>	-	<b>HF</b>	-	<b>2</b>	-	<b>06</b>	-	<b>13</b>	-	<b>6</b>
1		2		3		4		5		6

### 1 – Abbreviated designation

Code	Version
SEP	SEP

### 2 – Variant

Code	Type
HF	High Flow
HV	High Vacuum

### 3 – Nozzle technology

Code	Type
2	2 stage
3	3 stage

### 4 – Nozzle size

Code	Diameter in mm
03...16	ø 3 to 16

### 5 – Hole

Code	Diameter in mm
7...22	ø 7 to 22

### 6 – Additional function

Code	Type
5	Air saving function can be implemented

Ejector modules ecoPump SEP are delivered as a ready-to-connect product.

Available spare parts: set of spare parts ERS-SET

Available accessories: holder cap SHC, silencer SD, fixation element SFE, mounting bracket BEF-WIN, mounting set SET, quick exhaust valve SEV



## Ordering Data Ejector Modules ecoPump SEP

Type	Part no.
SEP HF 2 03 7	10.02.01.01341
SEP HF 2 06 13	10.02.01.01343
SEP HF 3 06 13	10.02.01.01344
SEP HF 2 13 22	10.02.01.01347
SEP HF 3 13 22	10.02.01.01348

Type	Part no.
SEP HV 2 04 7	10.02.01.01393
SEP HV 2 07 13	10.02.01.01394
SEP HV 3 07 13	10.02.01.01395
SEP HV 2 16 22	10.02.01.01396
SEP HV 3 16 22	10.02.01.01397
SEP HV 2 07 13 S	10.02.01.01406
SEP HV 3 07 13 S	10.02.01.01407
SEP HV 2 16 22 S	10.02.01.01410
SEP HV 3 16 22 S	10.02.01.01411



## Ordering Data Spare Parts Ejector Modules ecoPump SEP

Type	Spare Parts	Part no.
SEP 2 7	Set of spare parts	ERS-SET SEP-07 6xRUE-KLAP
SEP 2 13	Set of spare parts	ERS-SET SEP-13 6xRUE-KLAP
SEP 3 13	Set of spare parts	ERS-SET SEP-13 6xRUE-KLAP
SEP 2 22	Set of spare parts	ERS-SET SEP-22 6xRUE-KLAP
SEP 3 22	Set of spare parts	ERS-SET SEP-22 6xRUE-KLAP

# Ejector Modules ecoPump SEP

Suction rate up to 309 l/min



## Ordering Data Accessories Ejector Modules ecoPump SEP

Type	Holder cap SHC		Silencer
SEP 2 7	10.02.01.01510		-
SEP 2 13	10.02.01.01496		10.02.01.01498
SEP 3 13	10.02.01.01497		10.02.01.01498
SEP 2 22	10.02.01.01512		10.02.01.01517
SEP 3 22	10.02.01.01514		10.02.01.01517

Type	Fixation Element SFE	Mounting set	Mounting bracket	Quick exhaust valve
SEP 2 7	10.02.01.01464	-	10.08.03.00313	-
SEP 2 13	10.02.01.01419	10.02.01.01579	10.08.03.00314	10.02.01.01519
SEP 3 13	10.02.01.01419	10.02.01.01579	10.08.03.00314	10.02.01.01519
SEP 2 22	10.02.01.01421	10.02.01.01577	10.08.03.00315	10.02.01.01471
SEP 3 22	10.02.01.01421	10.02.01.01577	10.08.03.00315	10.02.01.01471



## Technical Data Ejector Modules ecoPump SEP

Type	Weight [g]	Operating temperature [°C]	Recomm. internal hose diameter compressed air [mm]	Recomm. internal hose diameter vacuum [mm]	Pressure range (operating pressure) [bar]	Noise level free [dB(A)]*	Noise level suction [dB(A)]
SEP 2 7	0.8	0 ... 60	2	4	2.0 ... 6.0	65	57
SEP 2 13	3.6	0 ... 60	4	6	2.0 ... 6.0	72	62
SEP 3 13	4.6	0 ... 60	4	6	2.0 ... 6.0	70	61
SEP 2 22	15.8	0 ... 60	6	12	2.0 ... 6.0	87	76
SEP 3 22	22.8	0 ... 60	6	12	2.0 ... 6.0	80	72

\*Reduction of noise level by 2-4 dB(A) due to holder cap SHC with silencer



## Performance Data Ejector Modules ecoPump SEP

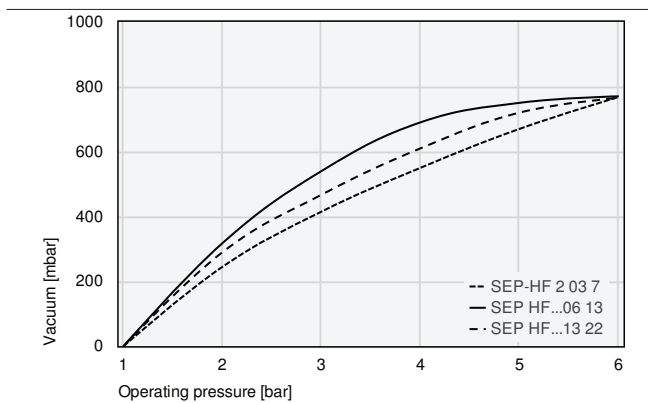

Achievable vacuum at various operating pressures

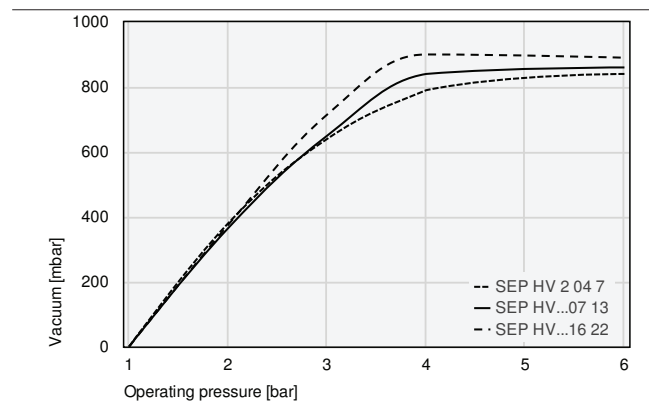

Achievable vacuum at various operating pressures

Schmalz - The Company  
Vacuum Suction Cups  
Special Grippers  
Gripping Systems  
Clamping Systems  
Mounting Elements  
Vacuum Generators  
Valve Technology  
Switches and Monitoring  
Filters and Connections  
Services  
Contact  
Glossary  
Index of Products



Suction rate up to 309 l/min



## Performance Data Ejector Modules ecoPump SEP

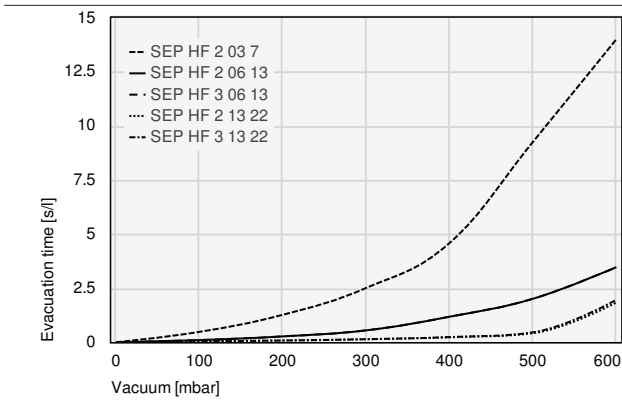

Evacuation times for various vacuum ranges [s/l]

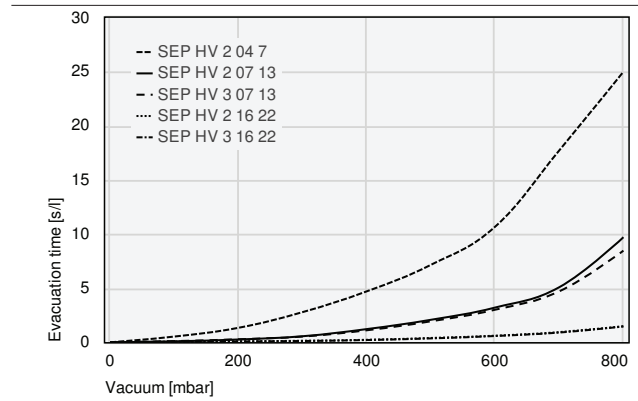

Evacuation times for various vacuum ranges [s/l]

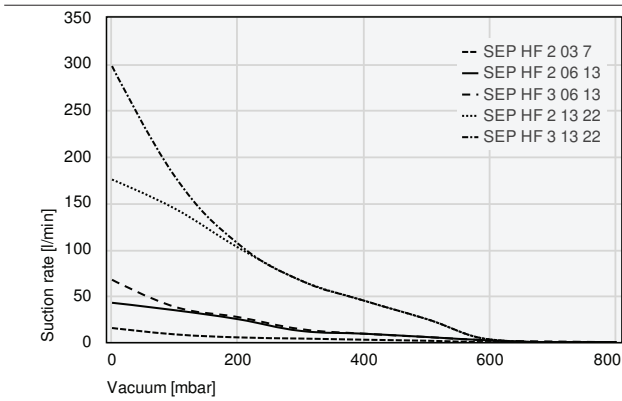

Suction capacity at various degrees of evacuation [l/min]

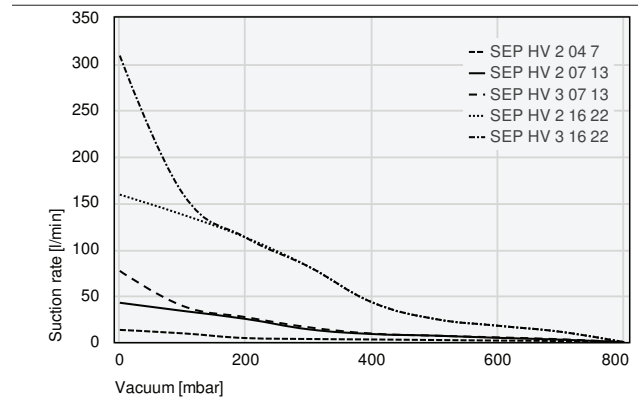

Suction capacity at various degrees of evacuation [l/min]



## Evacuation times for various vacuum ranges [s/l]

	100	200	300	400	500	600
SEP HF 2 03 7	0.48	1.27	2.51	4.59	9.26	14.00
SEP HF 2 06 13	0.10	0.27	0.55	1.18	2.01	3.47
SEP HF 3 06 13	0.10	0.27	0.55	1.18	2.01	3.47
SEP HF 2 13 22	0.04	0.08	0.14	0.23	0.42	1.84
SEP HF 3 13 22	0.04	0.08	0.14	0.24	0.46	1.96

	100	200	300	400	500	600	700	800
SEP HV 2 04 7	0.53	1.34	2.79	4.71	7.16	10.68	17.73	25.00
SEP HV 2 07 13	0.09	0.26	0.56	1.22	2.08	3.21	5.09	9.71
SEP HV 3 07 13	0.11	0.28	0.53	1.11	1.94	3.01	4.71	8.47
SEP HV 2 16 22	0.06	0.09	0.14	0.23	0.40	0.61	0.94	1.49
SEP HV 3 16 22	0.04	0.08	0.12	0.21	0.36	0.58	0.90	1.46

# Ejector Modules ecoPump SEP

Suction rate up to 309 l/min

- Schmalz – The Company
- Vacuum Suction Cups
- Special Grippers
- Gripping Systems
- Clamping Systems
- Mounting Elements
- Vacuum Generators
- Valve Technology
- Switches and Monitoring
- Filters and Connections
- Services
- Contact
- Glossary
- Index of Products

## Suction capacity at various degrees of evacuation [l/min]

	0	100	200	300	400	500	600	700
SEP HF 2 03 7	15.3	8.4	5.1	3.9	2.6	1.5	-	-
SEP HF 2 06 13	42.4	34.4	24.7	12.1	9.1	5.5	1.8	-
SEP HF 3 06 13	67.3	38.0	27.0	14.0	9.1	5.5	1.8	0.7
SEP HF 2 13 22	175.3	143.8	102.0	66.3	44.7	24.7	2.9	-
SEP HF 3 13 22	297.6	178.3	106.1	66.3	44.7	24.7	2.9	-

	0	100	200	300	400	500	600	700
SEP HV 2 04 7	13.2	9.5	4.4	3.4	2.9	2.3	1.7	1.2
SEP HV 2 07 13	42.5	33.7	25.0	13.8	8.8	7.0	4.6	2.7
SEP HV 3 07 13	76.8	39.0	26.9	16.0	9.3	7.0	5.1	3.1
SEP HV 2 16 22	159.0	137.4	112.7	81.3	43.0	25.0	17.7	11.1
SEP HV 3 16 22	308.9	160.0	112.7	81.3	43.0	25.0	17.7	11.1

## Design Data Ejector Modules ecoPump SEP

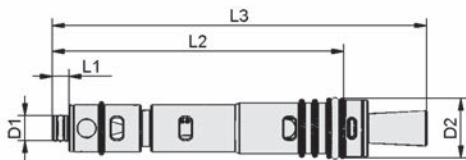

SEP

Type	D1 [mm]	D2 [mm]	L1 [mm]	L2 [mm]	L3 [mm]
SEP 2 7	4.4	6.8	3.5	20.1	33.0
SEP 2 13	5.4	12.8	5.0	41.5	55.5
SEP 3 13	5.4	12.8	5.0	63.5	81.5
SEP 2 22	10.8	21.8	8.0	67.5	92.0
SEP 3 22	10.8	21.8	8.0	103.0	146.0

# Basic Ejectors SBPL

Suction rate from 290 l/min to 1,140 l/min



Basic Ejectors SBPL

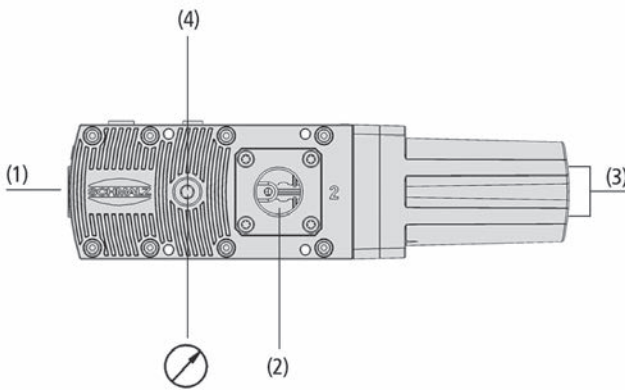

System Design Basic Ejectors SBPL



Centralized vacuum generation by means of basic ejectors SBPL

## Suitability for Industry Specific Applications

### Applications

- Basic ejector with highest suction rate for handling cardboard, packaging materials, insulation materials and other porous workpieces
- For processes that require high flow rates at minimized energy consumption

### Design

- Basic body and nozzle system made of high strength plastic
- Pneumatic connections for compressed air (1), vacuum (2) and exhaust air (silencer) (3)
- Connections for valve, vacuum switch or manometer (4)
- Optional accessories: vacuum switch, manometer, quick-release valves, electromagnetic valves

### Our Highlights...

- Ejector family with high suction capacity
- Area of operation for air-tight (HV) or porous (HF) workpieces
- Integrated eco nozzle technology
- Fast, with powerful vacuum
- Modular product design

### Your Benefits...

- Quick and safe handling of porous workpieces
- Reduced air consumption due to an optimized ejector operating area
- Highest energy efficiency in vacuum generation
- Quickly reaches working vacuum
- Quick and easy maintenance

- Schmalz – The Company
- Vacuum Suction Cups
- Special Grippers
- Gripping Systems
- Clamping Systems
- Mounting Elements
- Vacuum Generators
- Valve Technology
- Switches and Monitoring
- Filters and Connections
- Services
- Contact
- Glossary
- Index of Products



# Basic Ejectors SBPL

Suction rate from 290 l/min to 1,140 l/min

## Designation Code Basic Ejectors SBPL



1 – Abbreviated designation		2 – Size		3 – Variant	
Code	Version	Code	Type	Code	Type
SBPL	SBPL	25...150	25 to 150	HF	High Flow
				HV	High Vacuum

4 – Special thread	
Code	Type
NPT	NPT (thread)

The basic ejector SBPL is delivered as a ready-to-connect product.

Available accessories: retrofitting kit, sealing plug, manometer (vacuum gauge), quick-release valves (quick exhaust valve), electromagnetic valves (solenoid valve pressure), mounting bracket

## Ordering Data Basic Ejectors SBPL

Type			Size:					
			25	50	75	100	125	150
SBPL	HF	-	10.02.01.01596	10.02.01.01597	10.02.01.01650	10.02.01.01598	10.02.01.01652	10.02.01.01599
SBPL	HV	-	10.02.01.01586	10.02.01.01590	10.02.01.01649	10.02.01.01591	10.02.01.01651	10.02.01.01592
SBPL	HF	NPT	10.02.01.01604	10.02.01.01605	10.02.01.01654	10.02.01.01606	10.02.01.01656	10.02.01.01607
SBPL	HV	NPT	10.02.01.01600	10.02.01.01601	10.02.01.01653	10.02.01.01602	10.02.01.01655	10.02.01.01603

## Ordering Data Accessories Basic Ejectors SBPL

Type	Part no.
Retrofitting kit	SET SBPL 75/100 10.02.01.01685
Retrofitting kit	SET SBPL 125/150 10.02.01.01686
Sealing Plug (inst)	VRS-ST 15x101.7 SBPL 10.02.01.01687
Mouting bracket (inst.)	BEF-WIN 72x25x77 SBPL 10.02.01.01705
Solenoid valve pressure	EMV 3 24V-DC 2/2 NC K-2P 10.05.01.00366
Quick exhaust valve	SEV G1/8-IG G1/4-AG 10.02.01.01471
Vacuum gauge (electronic)	VAM-D 30x30 VP10 G1/8-AG 10.07.02.00055
Vacuum gauge	VAM 40 V H 10.07.02.00007

## Technical Data Basic Ejectors SBPL

Type	Degree of evacuation [%]	Suction rate [l/min]	Suction rate [m³/h]*	Air consumption suction [l/min]**	Air consumption suction [m³/h]	Noise level free [dB(A)]
SBPL 25 HF	60	290 (325)	17.4 (19.5)	80	5	61
SBPL 25 HV	90	300 (330)	18.0 (19.8)	105	7	65
SBPL 50 HF	60	500 (650)	30.0 (39.0)	160	10	65
SBPL 50 HV	90	510 (660)	30.6 (39.6)	210	13	66

\*The information regarding the suction capacity are values measured under operating conditions. The value in brackets represents the calculated suction capacity of the installed ejector modules. The measured value should always be applied for designs.

\*\*At optimal operating pressure

# Basic Ejectors SBPL

Suction rate from 290 l/min to 1,140 l/min



## Technical Data Basic Ejectors SBPL

Type	Degree of evacuation [%]	Suction rate [l/min]	Suction rate [m <sup>3</sup> /h]*	Air consumption suction [l/min]**	Air consumption suction [m <sup>3</sup> /h]	Noise level free [dB(A)]
SBPL 75 HF	60	710 (975)	42.6 (58.5)	230	14	67
SBPL 75 HV	90	720 (990)	43.2 (59.4)	305	19	68
SBPL 100 HF	60	860 (1,300)	51.6 (78.0)	300	19	69
SBPL 100 HV	90	870 (1,320)	52.2 (79.2)	395	25	70
SBPL 125 HF	60	1,010 (1,625)	60.6 (97.5)	370	23	70
SBPL 125 HV	90	1,010 (1,650)	60.6 (99.0)	470	29	72
SBPL 150 HF	60	1,120 (1,950)	67.2 (117.0)	435	27	71
SBPL 150 HV	90	1,140 (1,980)	68.4 (118.8)	545	34	73

\*The information regarding the suction capacity are values measured under operating conditions. The value in brackets represents the calculated suction capacity of the installed ejector modules. The measured value should always be applied for designs.

\*\*At optimal operating pressure

Type	Noise level suction [dB(A)]	Pressure range (operating pressure) [bar]	Recomm. internal hose diameter compressed air [mm]*	Recomm. internal hose diameter vacuum [mm]**	Weight [kg]	Operating temperature [°C]
SBPL 25 HF	54	2.0 ... 6.0	6	20	0.8	0 ... 60
SBPL 25 HV	55	2.0 ... 6.0	6	20	0.8	0 ... 60
SBPL 25 HF NPT	54	2.0 ... 6.0	6	20	0.8	0 ... 60
SBPL 25 HV NPT	55	2.0 ... 6.0	6	20	0.8	0 ... 60
SBPL 50 HF	55	2.0 ... 6.0	6	25	0.8	0 ... 60
SBPL 50 HV	59	2.0 ... 6.0	6	25	0.8	0 ... 60
SBPL 50 HF NPT	55	2.0 ... 6.0	6	25	0.8	0 ... 60
SBPL 50 HV NPT	59	2.0 ... 6.0	6	25	0.8	0 ... 60
SBPL 75 HF	57	2.0 ... 6.0	9	32	1.1	0 ... 60
SBPL 75 HV	62	2.0 ... 6.0	9	32	1.1	0 ... 60
SBPL 75 HF NPT	57	2.0 ... 6.0	9	32	1.1	0 ... 60
SBPL 75 HV NPT	62	2.0 ... 6.0	9	32	1.1	0 ... 60
SBPL 100 HF	58	2.0 ... 6.0	9	32	1.1	0 ... 60
SBPL 100 HV	64	2.0 ... 6.0	9	32	1.1	0 ... 60
SBPL 100 HF NPT	58	2.0 ... 6.0	9	32	1.1	0 ... 60
SBPL 100 HV NPT	64	2.0 ... 6.0	9	32	1.1	0 ... 60
SBPL 125 HF	60	2.0 ... 6.0	11	32	1.5	0 ... 60
SBPL 125 HV	65	2.0 ... 6.0	11	32	1.5	0 ... 60
SBPL 125 HF NPT	60	2.0 ... 6.0	11	32	1.5	0 ... 60
SBPL 125 HV NPT	65	2.0 ... 6.0	11	32	1.5	0 ... 60
SBPL 150 HF	61	2.0 ... 6.0	11	32	1.5	0 ... 60
SBPL 150 HV	66	2.0 ... 6.0	11	32	1.5	0 ... 60
SBPL 150 HF NPT	61	2.0 ... 6.0	11	32	1.5	0 ... 60
SBPL 150 HV NPT	66	2.0 ... 6.0	11	32	1.5	0 ... 60

\*For max. length 2 m

\*\*For max. length 2 m

# Basic Ejectors SBPL

Suction rate from 290 l/min to 1,140 l/min

- Schmalz – The Company
- Vacuum Suction Cups
- Special Grippers
- Gripping Systems
- Clamping Systems
- Mounting Elements
- Vacuum Generators
- Valve Technology
- Switches and Monitoring
- Filters and Connections
- Services
- Contact
- Glossary
- Index of Products

## Performance Data Basic Ejectors SBPL

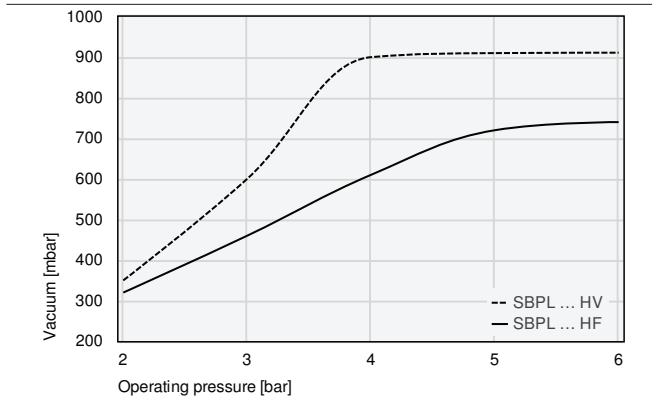

Achievable vacuum at various operating pressures

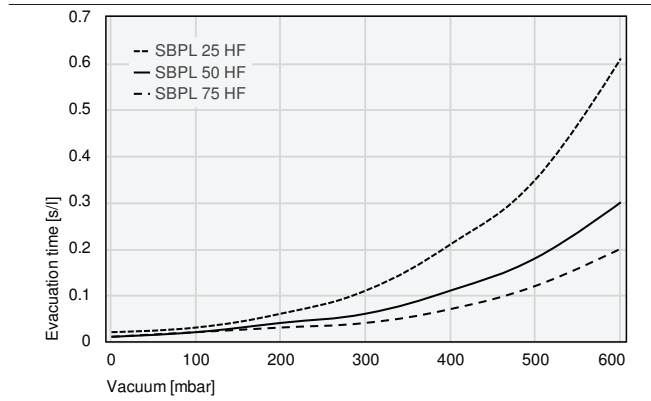

Evacuation times for various vacuum ranges [s/l]

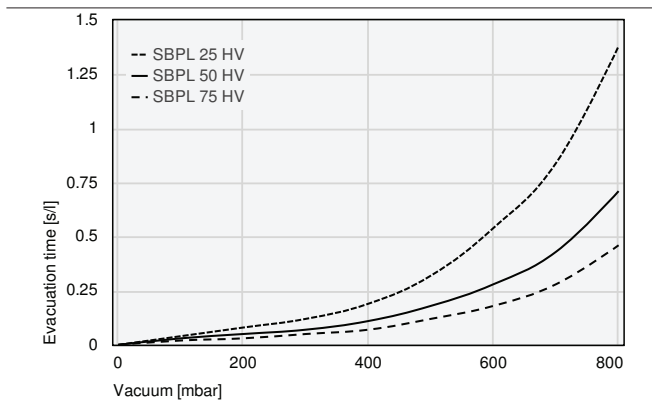

Evacuation times for various vacuum ranges [s/l]

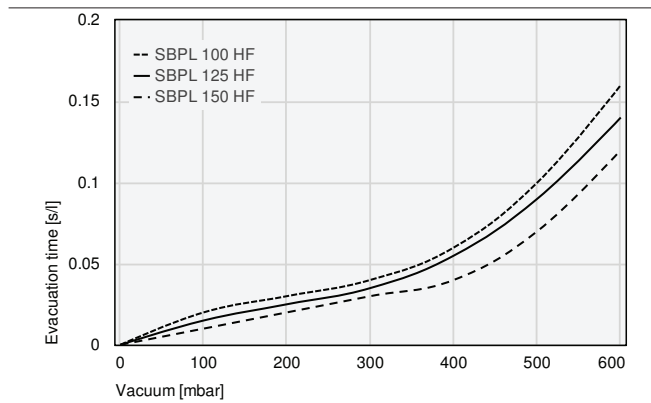

Evacuation times for various vacuum ranges [s/l]

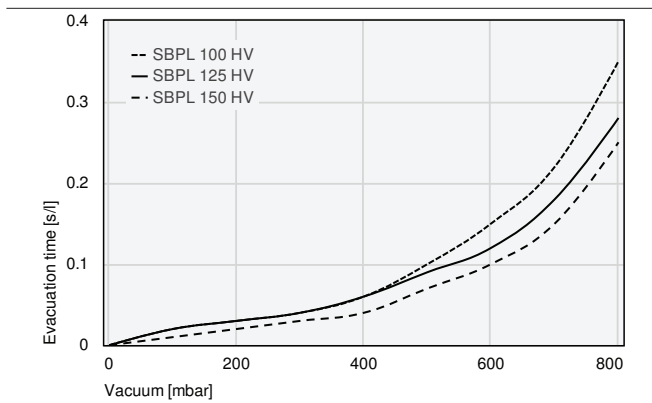

Evacuation times for various vacuum ranges [s/l]

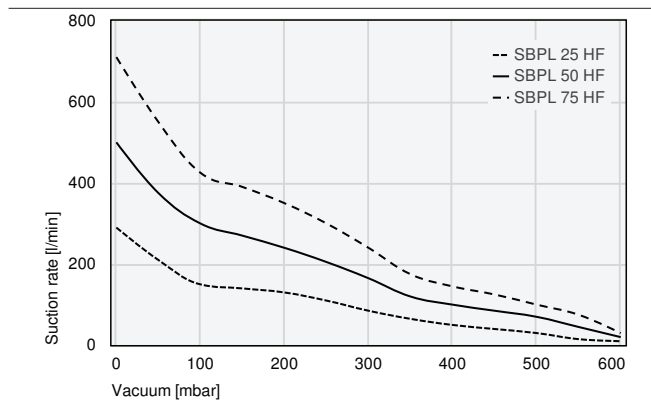

Suction capacity at various degrees of evacuation [l/min]

# Basic Ejectors SBPL

Suction rate from 290 l/min to 1,140 l/min



## Performance Data Basic Ejectors SBPL

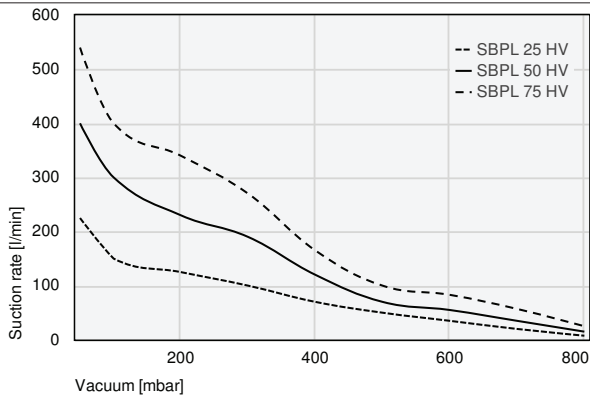

Suction capacity at various degrees of evacuation [l/min]

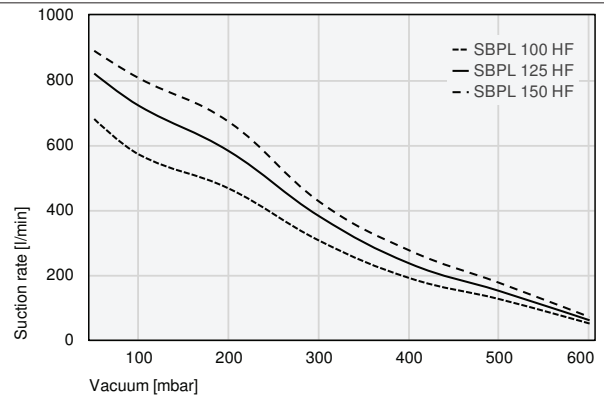

Suction capacity at various degrees of evacuation [l/min]

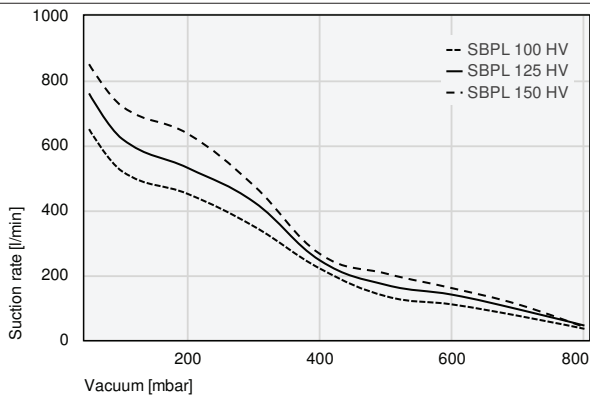

Suction capacity at various degrees of evacuation [l/min]



## Evacuation times for various vacuum ranges [s/l]

	100	200	300	400	500	600
SBPL 25 HF	0.03	0.06	0.11	0.21	0.35	0.61
SBPL 50 HF	0.02	0.04	0.06	0.11	0.18	0.30
SBPL 75 HF	0.02	0.03	0.04	0.07	0.12	0.20

	100	200	300	400	500	600	700	800
SBPL 25 HV	0.04	0.08	0.12	0.19	0.32	0.54	0.84	1.38
SBPL 50 HV	0.03	0.05	0.07	0.11	0.18	0.28	0.43	0.71
SBPL 75 HV	0.02	0.03	0.05	0.07	0.12	0.18	0.28	0.46

# Basic Ejectors SBPL

Suction rate from 290 l/min to 1,140 l/min



## Evacuation times for various vacuum ranges [s/l]

	100	200	300	400	500	600
SBPL 100 HF	0.02	0.03	0.04	0.06	0.10	0.16
SBPL 125 HF	0.02	0.03	0.04	0.06	0.09	0.14
SBPL 150 HF	0.01	0.02	0.03	0.04	0.07	0.12

	100	200	300	400	500	600	700	800
SBPL 100 HV	0.02	0.03	0.04	0.06	0.10	0.15	0.22	0.35
SBPL 125 HV	0.02	0.03	0.04	0.06	0.09	0.12	0.18	0.28
SBPL 150 HV	0.01	0.02	0.03	0.04	0.07	0.10	0.15	0.25



## Suction capacity at various degrees of evacuation [l/min]

	0	50	100	200	300	400	500	600
SBPL 25 HF	290	210	150	130	85	50	30	10
SBPL 50 HF	500	375	300	240	165	100	70	20
SBPL 75 HF	710	550	425	350	240	145	100	30

	50	100	200	300	400	500	600	700	800
SBPL 25 HV	225	150	125	100	70	50	35	20	8
SBPL 50 HV	400	300	230	190	120	70	55	35	15
SBPL 75 HV	540	400	340	270	165	100	83	57	25

	50	100	200	300	400	500	600	800
SBPL 100 HF	680	570	465	305	190	125	50	
SBPL 125 HF	820	720	580	380	235	150	60	
SBPL 150 HF	890	805	670	425	275	175	70	

	50	100	200	300	400	500	600	700	800
SBPL 100 HV	650	520	450	350	220	135	110	75	35
SBPL 125 HV	760	620	530	425	245	170	140	95	45
SBPL 150 HV	850	720	635	475	265	205	160	110	40



# Basic Ejectors SBPL

Suction rate from 290 l/min to 1,140 l/min



## Design Data Basic Ejectors SBPL

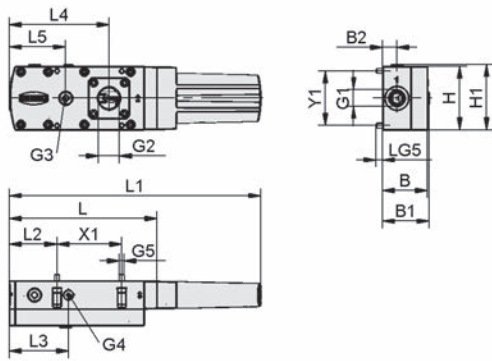

SBPL 25/50

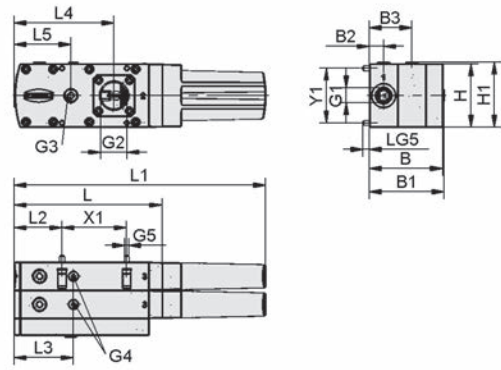

SBPL 75/100

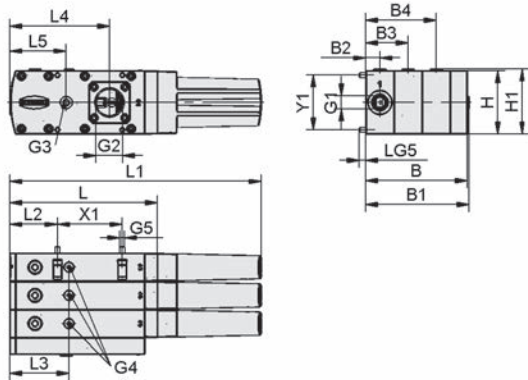

SBPL 125/150

Schmalz –  
The Company

Vacuum  
Suction Cups

Special  
Grippers

Gripping  
Systems

Clamping  
Systems

Mounting  
Elements

Vacuum  
Generators

Valve  
Technology

Switches and  
Monitoring

Filters and  
Connections

Services

Contact

Glossary

Index of  
Products



# Basic Ejectors SBPL

Suction rate from 290 l/min to 1,140 l/min



## Design Data Basic Ejectors SBPL

Type	B [mm]	B1 [mm]	B2 [mm]	B3 [mm]	B4 [mm]	G1	G2	G3	G4	G5	H [mm]
SBPL 25 HF	51	53	16	-	-	G3/8"-F	G3/4"-F	G1/4"-F	G1/8"-F	M5-M	72
SBPL 25 HV	51	53	16	-	-	G3/8"-F	G3/4"-F	G1/4"-F	G1/8"-F	M5-M	72
SBPL 25 HF NPT	51	53	16	-	-	NPT3/8-F	NPT3/4-F	NPT1/4-F	G1/8"-F	M5-M	72
SBPL 25 HV NPT	51	53	16	-	-	NPT3/8-F	NPT3/4-F	NPT1/4-F	G1/8"-F	M5-M	72
SBPL 50 HF	51	53	16	-	-	G3/8"-F	G3/4"-F	G1/4"-F	G1/8"-F	M5-M	72
SBPL 50 HV	51	53	16	-	-	G3/8"-F	G3/4"-F	G1/4"-F	G1/8"-F	M5-M	72
SBPL 50 HF NPT	51	53	16	-	-	NPT3/8-F	NPT3/4-F	NPT1/4-F	G1/8"-F	M5-M	72
SBPL 50 HV NPT	51	53	16	-	-	NPT3/8-F	NPT3/4-F	NPT1/4-F	G1/8"-F	M5-M	72
SBPL 75 HF	83	85	16	48	-	G3/8"-F	G1"-F	G1/4"-F	G1/8"-F	M5-M	72
SBPL 75 HV	83	85	16	48	-	G3/8"-F	G1"-F	G1/4"-F	G1/8"-F	M5-M	72
SBPL 75 HF NPT	83	85	16	48	-	NPT3/8-F	NPT1-F	NPT1/4-F	G1/8"-F	M5-M	72
SBPL 75 HV NPT	83	85	16	48	-	NPT3/8-F	NPT1-F	NPT1/4-F	G1/8"-F	M5-M	72
SBPL 100 HF	83	85	16	48	-	G3/8"-F	G1"-F	G1/4"-F	G1/8"-F	M5-M	72
SBPL 100 HV	83	85	16	48	-	G3/8"-F	G1"-F	G1/4"-F	G1/8"-F	M5-M	72
SBPL 100 HF NPT	83	85	16	48	-	NPT3/8-F	NPT1-F	NPT1/4-F	G1/8"-F	M5-M	72
SBPL 100 HV NPT	83	85	16	48	-	NPT3/8-F	NPT1-F	NPT1/4-F	G1/8"-F	M5-M	72
SBPL 125 HF	115	117	16	48	80	G3/8"-F	G1"-F	G1/4"-F	G1/8"-F	M5-M	72
SBPL 125 HV	115	117	16	48	80	G3/8"-F	G1"-F	G1/4"-F	G1/8"-F	M5-M	72
SBPL 125 HF NPT	115	117	16	48	80	NPT3/8-F	NPT1-F	NPT1/4-F	G1/8"-F	M5-M	72
SBPL 125 HV NPT	115	117	16	48	80	NPT3/8-F	NPT1-F	NPT1/4-F	G1/8"-F	M5-M	72
SBPL 150 HF	115	117	16	48	80	G3/8"-F	G1"-F	G1/4"-F	G1/8"-F	M5-M	72
SBPL 150 HV	115	117	16	48	80	G3/8"-F	G1"-F	G1/4"-F	G1/8"-F	M5-M	72
SBPL 150 HF NPT	115	117	16	48	80	NPT3/8-F	NPT1-F	NPT1/4-F	G1/8"-F	M5-M	72
SBPL 150 HV NPT	115	117	16	48	80	NPT3/8-F	NPT1-F	NPT1/4-F	G1/8"-F	M5-M	72

Type	H1 [mm]	L [mm]	L1 [mm]	L2 [mm]	L3 [mm]	L4 [mm]	L5 [mm]	LG5 [mm]	X1 [mm]	Y1 [mm]
SBPL 25 HF	74	168	285	54	67	113	64	8.5	74	62
SBPL 25 HV	74	168	285	54	67	113	64	8.5	74	62
SBPL 25 HF NPT	74	168	285	54	67	113	64	8.5	74	62
SBPL 25 HV NPT	74	168	285	54	67	113	64	8.5	74	62
SBPL 50 HF	74	168	285	54	67	113	64	8.5	74	62
SBPL 50 HV	74	168	285	54	67	113	64	8.5	74	62
SBPL 50 HF NPT	74	168	285	54	67	113	64	8.5	74	62
SBPL 50 HV NPT	74	168	285	54	67	113	64	8.5	74	62
SBPL 75 HF	74	168	285	54	67	113	64	8.5	74	62
SBPL 75 HV	74	168	285	54	67	113	64	8.5	74	62
SBPL 75 HF NPT	74	168	285	54	67	113	64	8.5	74	62
SBPL 75 HV NPT	74	168	285	54	67	113	64	8.5	74	62
SBPL 100 HF	74	168	285	54	67	113	64	8.5	74	62
SBPL 100 HV	74	168	285	54	67	113	64	8.5	74	62
SBPL 100 HF NPT	74	168	285	54	67	113	64	8.5	74	62
SBPL 100 HV NPT	74	168	285	54	67	113	64	8.5	74	62
SBPL 125 HF	74	168	285	54	67	113	64	8.5	74	62
SBPL 125 HV	74	168	285	54	67	113	64	8.5	74	62
SBPL 125 HF NPT	74	168	285	54	67	113	64	8.5	74	62
SBPL 125 HV NPT	74	168	285	54	67	113	64	8.5	74	62
SBPL 150 HF	74	168	285	54	67	113	64	8.5	74	62
SBPL 150 HV	74	168	285	54	67	113	64	8.5	74	62
SBPL 150 HF NPT	74	168	285	54	67	113	64	8.5	74	62
SBPL 150 HV NPT	74	168	285	54	67	113	64	8.5	74	62



# Basic Ejectors SEG

Suction rate from 7 l/min to 370 l/min



Basic Ejectors SEG

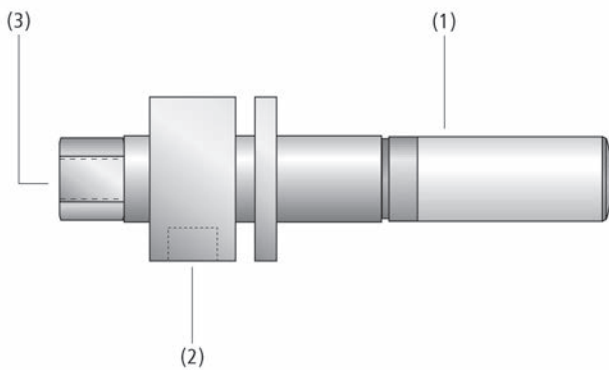

System Design Basic Ejectors SEG



Decentral vacuum generation by means of basic ejectors SEG for handling plastic parts

## Suitability for Industry Specific Applications

### Applications

- Basic ejector for universal use in vacuum systems
- Various handling tasks in the automotive, metal sheet, wood, assembly technology, food and packing industries

### Design

- Body made of anodized aluminum
- Nozzle system made of brass
- Plastic silencer (1)
- Vacuum connection (2)
- Compressed air connection (3)

### Our Highlights...

- Body with Venturi nozzle and optionally with silencer
- Minimum size; low weight due to aluminum body
- Various models with different performance figures; optimized for maximum efficiency

### Your Benefits...

- No moving parts: no wear and no maintenance needed
- Suitable for small spaces and highly dynamic movements, such as on manipulators, industrial robots, feeder systems, etc.
- Very efficient: maximum suction capacity with minimum compressed air consumption

# Basic Ejectors SEG

Suction rate from 7 l/min to 370 l/min

## Designation Code Basic Ejectors SEG



### 1 – Abbreviated designation

Code	Version
SEG	SEG

### 2 – Nozzle size

Code	Diameter in mm
05...30	ø 0.5 to 3

### 3 – Design

Code	Type
HS	High speed (high vacuum)
HS-S	High speed and narrow design
LS	Low speed (high suction capacity)

### 4 – Variant

Code	Type
SDA	Silencer axial

The basic ejector SEG is delivered as a ready-to-connect product.

Available spare parts: silencer

## Ordering Data Basic Ejectors SEG

Type	Part no.
SEG 05 HS-S	10.02.01.00272
SEG 05 HS-S SDA	10.02.01.00271
SEG 07 HS-S	10.02.01.00276
SEG 07 HS-S SDA	10.02.01.00275
SEG 07 HS	10.02.01.00255
SEG 07 HS SDA	10.02.01.00110
SEG 10 HS	10.02.01.00247
SEG 10 HS SDA	10.02.01.00111
SEG 15 HS	10.02.01.00248
SEG 15 HS SDA	10.02.01.00112
SEG 20 HS	10.02.01.00256
SEG 20 HS SDA	10.02.01.00113
SEG 20 LS	10.02.01.00252
SEG 20 LS SDA	10.02.01.00114
SEG 25 HS	10.02.01.00257
SEG 25 HS SDA	10.02.01.00115
SEG 25 LS	10.02.01.00259
SEG 25 LS SDA	10.02.01.00116
SEG 30 HS	10.02.01.00258
SEG 30 HS SDA	10.02.01.00117
SEG 30 LS	10.02.01.00260
SEG 30 LS SDA	10.02.01.00118

Schmalz – The Company  
 Vacuum Suction Cups  
 Special Grippers  
 Gripping Systems  
 Clamping Systems  
 Mounting Elements  
 Vacuum Generators  
 Valve Technology  
 Switches and Monitoring  
 Filters and Connections  
 Services  
 Contact  
 Glossary  
 Index of Products

# Basic Ejectors SEG

Suction rate from 7 l/min to 370 l/min



## Ordering Data Spare Parts Basic Ejectors SEG

Type	Spare Parts		Part no.
SEG 05 HS-S SDA	Silencer (round)	SD M5-AG 9x24	10.02.01.00539
SEG 07 HS-S SDA	Silencer (round)	SD M5-AG 9x24	10.02.01.00539
SEG 07 HS SDA	Silencer (round)	SD G1/8-AG 14x40	10.02.01.00540
SEG 10 HS SDA	Silencer (round)	SD G1/8-AG 14x40	10.02.01.00540
SEG 15 HS SDA	Silencer (round)	SD G1/4-AG 20x46 SEG	10.02.01.00903
SEG 20 HS SDA	Silencer (round)	SD G3/8-AG 20x56 SEG	10.02.01.00905
SEG 20 LS SDA	Silencer (round)	SD G3/8-AG 20x56 SEG	10.02.01.00905
SEG 25 HS SDA	Silencer (round)	SD G1/2-AG 27x63 SEG	10.02.01.00907
SEG 25 LS SDA	Silencer (round)	SD G1/2-AG 27x63 SEG	10.02.01.00907
SEG 30 HS SDA	Silencer (round)	SD G3/4-AG 31x90 SEG	10.02.01.00909
SEG 30 LS SDA	Silencer (round)	SD G3/4-AG 31x90 SEG	10.02.01.00909



## Technical Data Basic Ejectors SEG

Type	Nozzle diameter [mm]	Degree of evacuation [%]	Suction rate (max.) [l/min]	Suction rate (max.) [m³/h]	Air consumption suction [l/min]*	Air consumption suction [m³/h]	Pressure range (operating pressure) [bar]	Recomm. internal hose diameter compressed air [mm]**	Recomm. internal hose diameter vacuum [mm]***	Weight [g]	Operating temperature [°C]
SEG 05 HS-S	0.5	82	7	0.4	13	0.8	3.0 ... 6.0	2	2	10	-10 ... 80
SEG 05 HS-S SDA	0.5	82	7	0.4	13	0.8	3.0 ... 6.0	2	2	11	-10 ... 80
SEG 07 HS-S	0.7	82	16	1.0	21	1.3	3.0 ... 6.0	2	2	10	-10 ... 80
SEG 07 HS-S SDA	0.7	82	16	1.0	21	1.3	3.0 ... 6.0	2	2	11	-10 ... 80
SEG 07 HS	0.7	85	14	0.8	21	1.3	3.0 ... 6.0	2	4	41	-10 ... 80
SEG 07 HS SDA	0.7	85	14	0.8	21	1.3	3.0 ... 6.0	2	4	45	-10 ... 80
SEG 10 HS	1.0	85	34	2.0	49	2.9	3.0 ... 6.0	2	4	46	-10 ... 80
SEG 10 HS SDA	1.0	85	34	2.0	49	2.9	3.0 ... 6.0	2	4	50	-10 ... 80
SEG 15 HS	1.5	85	69	4.1	102	6.1	3.0 ... 6.0	4	6	102	-10 ... 80
SEG 15 HS SDA	1.5	85	69	4.1	102	6.1	3.0 ... 6.0	4	6	110	-10 ... 80
SEG 20 HS	2.0	85	124	7.4	186	11.2	3.0 ... 6.0	4	9	118	-10 ... 80
SEG 20 HS SDA	2.0	85	124	7.4	186	11.2	3.0 ... 6.0	4	9	130	-10 ... 80
SEG 20 LS	2.0	55	170	10.2	186	11.2	3.0 ... 6.0	4	9	118	-10 ... 80
SEG 20 LS SDA	2.0	55	170	10.2	186	11.2	3.0 ... 6.0	4	9	130	-10 ... 80
SEG 25 HS	2.5	85	184	11.0	275	16.5	3.0 ... 6.0	6	12	273	-10 ... 80
SEG 25 HS SDA	2.5	85	184	11.0	275	16.5	3.0 ... 6.0	6	12	295	-10 ... 80
SEG 25 LS	2.5	55	260	15.6	275	16.5	3.0 ... 6.0	6	12	273	-10 ... 80
SEG 25 LS SDA	2.5	55	260	15.6	275	16.5	3.0 ... 6.0	6	12	295	-10 ... 80
SEG 30 HS	3.0	85	240	14.4	392	23.5	3.0 ... 6.0	6	12	352	-10 ... 80
SEG 30 HS SDA	3.0	85	240	14.4	392	23.5	3.0 ... 6.0	6	12	404	-10 ... 80
SEG 30 LS	3.0	55	370	22.2	392	23.5	3.0 ... 6.0	6	12	352	-10 ... 80
SEG 30 LS SDA	3.0	55	370	22.2	392	23.5	3.0 ... 6.0	6	12	404	-10 ... 80

\*At optimal operating pressure

\*\*For max. length 2 m

\*\*\*For max. length 2 m



# Basic Ejectors SEG

Suction rate from 7 l/min to 370 l/min

- Schmalz – The Company
- Vacuum Suction Cups
- Special Grippers
- Gripping Systems
- Clamping Systems
- Mounting Elements
- Vacuum Generators
- Valve Technology
- Switches and Monitoring
- Filters and Connections
- Services
- Contact
- Glossary
- Index of Products



## Performance Data Basic Ejectors SEG

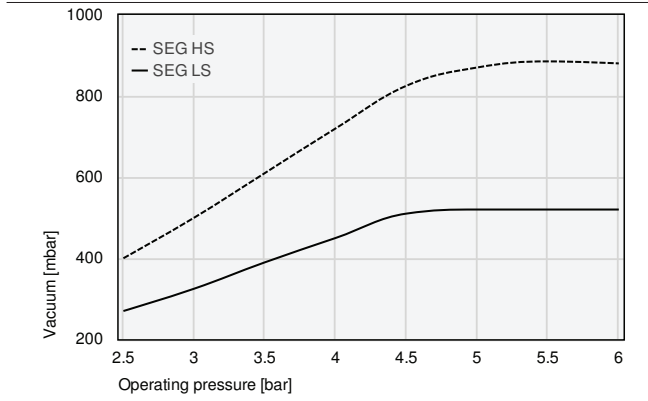

Achievable vacuum at various operating pressures

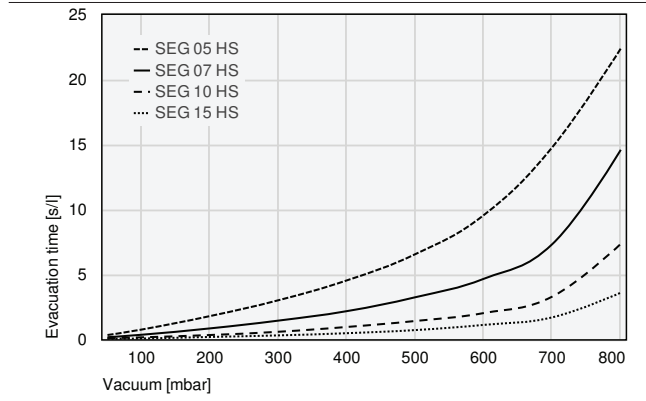

Evacuation times for various vacuum ranges [s/l]

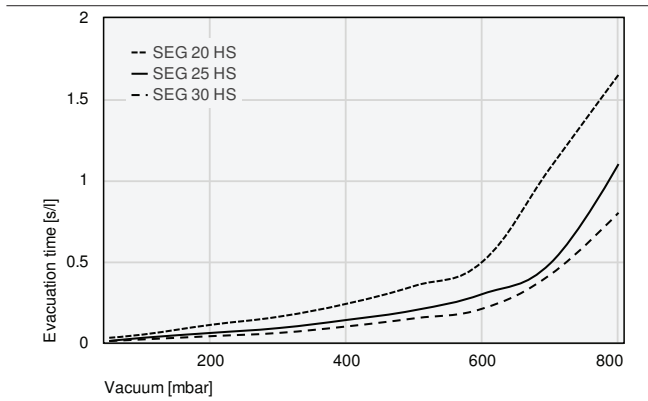

Evacuation times for various vacuum ranges [s/l]

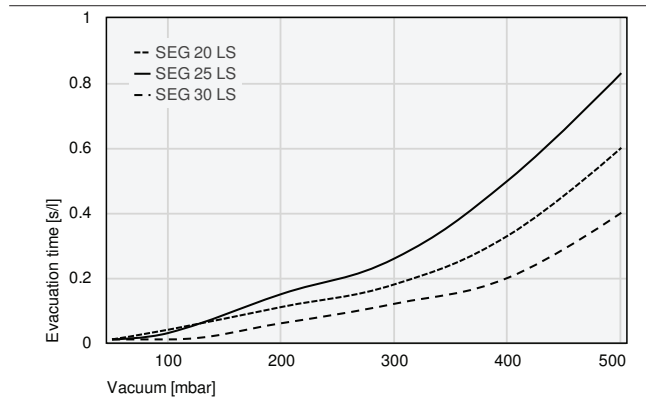

Evacuation times for various vacuum ranges [s/l]

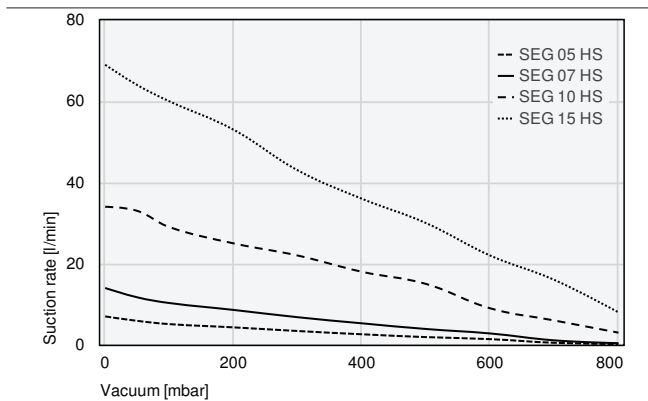

Suction capacity at various degrees of evacuation [l/min]

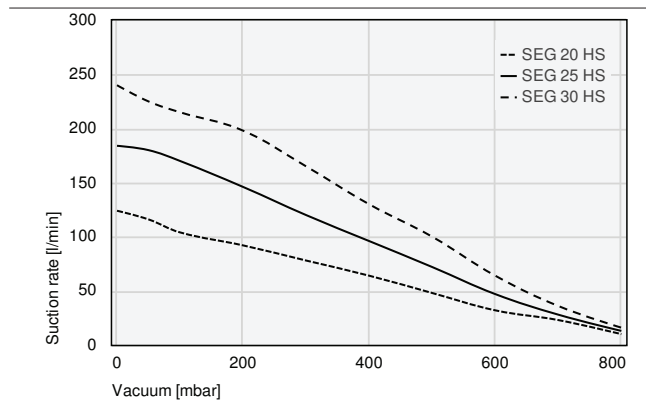

Suction capacity at various degrees of evacuation [l/min]

# Basic Ejectors SEG

Suction rate from 7 l/min to 370 l/min



## Performance Data Basic Ejectors SEG

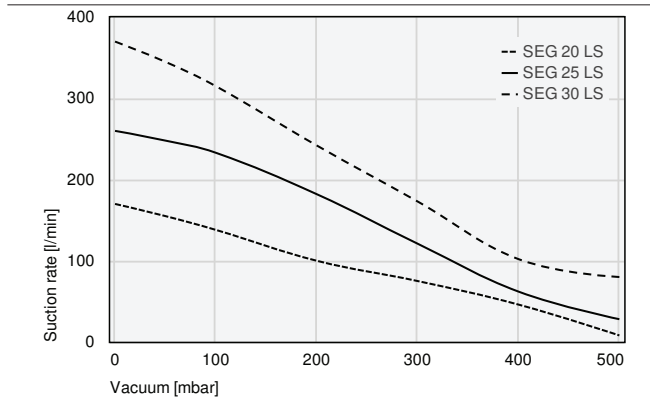

Suction capacity at various degrees of evacuation [l/min]



## Evacuation times for various vacuum ranges [s/l]

	50	100	200	300	400	500	600	700	800
SEG 05 HS	0.34	0.76	1.80	3.02	4.55	6.57	9.58	14.80	22.40
SEG 07 HS	0.17	0.36	0.85	1.45	2.18	3.25	4.67	7.34	14.60
SEG 10 HS	0.09	0.16	0.34	0.59	0.96	1.42	2.03	3.30	7.36
SEG 15 HS	0.05	0.07	0.19	0.31	0.48	0.72	1.12	1.70	3.60

	50	100	200	300	400	500	600	700	800
SEG 20 HS	0.03	0.05	0.11	0.16	0.24	0.35	0.50	1.08	1.65
SEG 25 HS	0.01	0.03	0.06	0.09	0.14	0.20	0.30	0.49	1.10
SEG 30 HS	0.01	0.02	0.04	0.06	0.10	0.15	0.21	0.42	0.80

	50	100	200	300	400	500
SEG 20 LS	0.01	0.04	0.11	0.18	0.33	0.60
SEG 25 LS	0.01	0.03	0.15	0.26	0.50	0.83
SEG 30 LS	0.01	0.01	0.06	0.12	0.20	0.40



## Suction capacity at various degrees of evacuation [l/min]

	0	50	100	200	300	400	500	600	700	800
SEG 05 HS	7.0	5.9	5.1	4.3	3.4	2.6	1.9	1.4	0.5	0.2
SEG 07 HS	14.0	11.7	10.3	8.6	6.8	5.3	3.9	2.8	1.1	0.4
SEG 10 HS	34.0	33.0	29.0	25.0	22.0	18.0	15.0	9.0	6.0	3.0
SEG 15 HS	69.0	64.0	60.0	53.0	43.0	36.0	30.0	22.0	16.0	8.0

	0	50	100	200	300	400	500	600	700	800
SEG 20 HS	124	116	104	92	78	64	48	32	23	10
SEG 25 HS	184	180	170	146	120	96	72	47	28	13
SEG 30 HS	240	225	215	198	165	130	100	64	36	16



# Basic Ejectors SEG

Suction rate from 7 l/min to 370 l/min

Schmalz - The Company  
Vacuum Suction Cups  
Special Grippers  
Gripping Systems  
Clamping Systems  
Mounting Elements  
Vacuum Generators  
Valve Technology  
Switches and Monitoring  
Filters and Connections  
Services  
Contact  
Glossary  
Index of Products

## Suction capacity at various degrees of evacuation [l/min]

	0	50	100	200	300	400	500
SEG 20 LS	170	155	138	100	75	46	8
SEG 25 LS	260	248	233	182	121	62	28
SEG 30 LS	370	345	315	242	173	102	80

## Design Data Basic Ejectors SEG

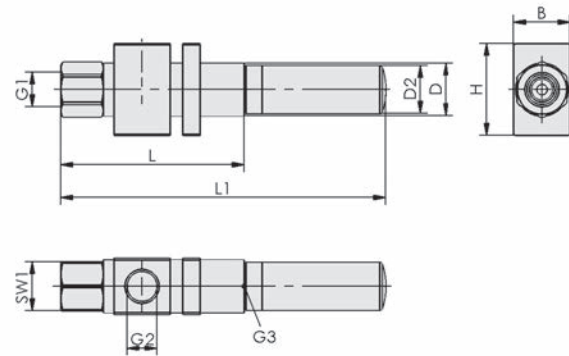
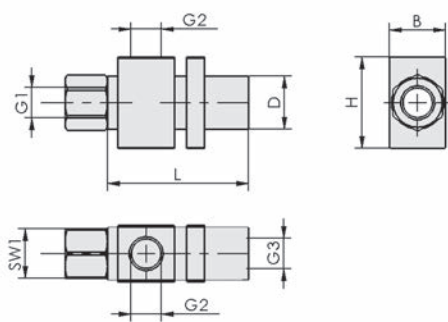

SEG

SEG SDA

Type	B [mm]	D [mm]	D2 [mm]	G1	G2	G3	H [mm]	L [mm]	L1 [mm]	SW1 [mm]
SEG 05 HS-S	10	8.0	-	M5-F	M5-F	M5-F	20	41	-	8
SEG 05 HS-S SDA	10	8.0	9	M5-F	M5-F	M5-F	20	41	65	8
SEG 07 HS-S	10	8.0	-	M5-F	M5-F	M5-F	20	40	-	8
SEG 07 HS-S SDA	10	8.0	9	M5-F	M5-F	M5-F	20	40	65	8
SEG 07 HS	16	15.0	-	G1/8"-F	G1/8"-F	G1/8"-F	26	52	-	14
SEG 07 HS SDA	16	15.0	15	G1/8"-F	G1/8"-F	G1/8"-F	26	52	92	14
SEG 10 HS	16	15.0	-	G1/8"-F	G1/8"-F	G1/8"-F	26	57	-	14
SEG 10 HS SDA	16	15.0	15	G1/8"-F	G1/8"-F	G1/8"-F	26	57	97	14
SEG 15 HS	22	20.0	-	G1/4"-F	G1/4"-F	G1/4"-F	38	75	-	17
SEG 15 HS SDA	22	20.0	20	G1/4"-F	G1/4"-F	G1/4"-F	38	75	121	17
SEG 20 HS	26	20.0	-	G1/4"-F	G1/4"-F	G3/8"-F	38	90	-	17
SEG 20 HS SDA	26	20.0	20	G1/4"-F	G1/4"-F	G3/8"-F	38	90	146	17
SEG 20 LS	26	20.0	-	G1/4"-F	G1/4"-F	G3/8"-F	38	90	-	17
SEG 20 LS SDA	26	20.0	20	G1/4"-F	G1/4"-F	G3/8"-F	38	90	146	17
SEG 25 HS	32	28.0	-	G3/8"-F	G1/2"-F	G1/2"-F	50	117	-	22
SEG 25 HS SDA	32	28.0	28	G3/8"-F	G1/2"-F	G1/2"-F	50	117	180	22
SEG 25 LS	32	28.0	-	G3/8"-F	G1/2"-F	G1/2"-F	50	117	-	22
SEG 25 LS SDA	32	28.0	28	G3/8"-F	G1/2"-F	G1/2"-F	50	117	180	22
SEG 30 HS	42	32.0	-	G3/8"-F	G1/2"-F	G3/4"-F	50	127	-	22
SEG 30 HS SDA	42	32.0	32	G3/8"-F	G1/2"-F	G3/4"-F	50	127	217	22
SEG 30 LS	42	32.0	-	G3/8"-F	G1/2"-F	G3/4"-F	50	127	-	22
SEG 30 LS SDA	42	32.0	32	G3/8"-F	G1/2"-F	G3/4"-F	50	127	217	22





# Basic Ejectors SBP

Suction rate from 8 l/min to 215 l/min



Basic Ejectors SBP

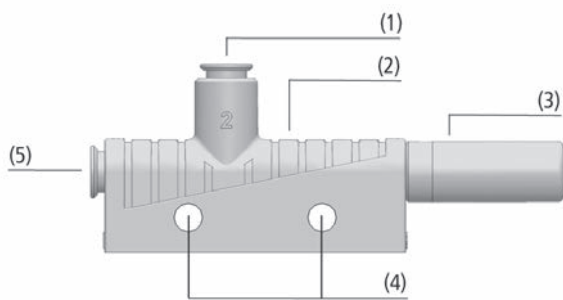

System Design Basic Ejectors SBP

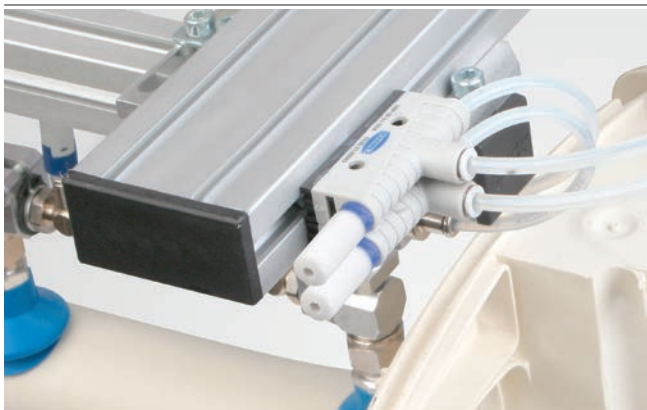

Central vacuum generation by basic ejectors SBP for handling plastic injection molded parts

## Suitability for Industry Specific Applications

### Applications

- Basic ejector with plastic housing for use in feeder systems
- Handling of electronic components
- Use in separation systems for plastic and sheet-metal machining
- Construction of ejector blocks for decentralized individual control of suction cups

### Design

- One piece housing (2) made of light, impact resistant plastic
- Connection of compressed air (5) and vacuum (1) with quick action push-in coupling (S01 to S03) or threaded holes (G01 to G03)
- Open silencer (3)
- Vacuum generator with single nozzle, available in six power ratings, 0.5 to 2.5 mm
- Can be fixed horizontally with mounting holes (4) or vertically with the base on a mounting plate
- Optional mounting with mounting plate and mounting kit on DIN top-hat rails

### Our Highlights...

- Plastic housing optimized for weight and size
- Ejector nozzles with six different power ratings
- Connections either with threaded holes or push-in couplings
- Open silencer

### Your Benefits...

- Ideal for decentralized vacuum generation in highly dynamic processes
- Various power ratings for minimum air consumption
- Space saving and easy to install
- Low noise levels and minimum maintenance requirements

# Basic Ejectors SBP

Suction rate from 8 l/min to 215 l/min

## Designation Code Basic Ejectors SBP



### 1 – Abbreviated designation

Code	Version
SBP	SBP

### 2 – Nozzle size

Code	Diameter in mm
05...25	ø 0.5 to 2.5

### 3 – Connection

Code	Connection
G01	Connection thread 1
G02	Connection thread 2
G03	Connection thread 3
S01	Quick connect push-in coupling 1
S02	Quick connect push-in coupling 2
S03	Quick connect push-in coupling 3

### 4 – Variant

Code	Type
SDA	Silencer axial

The basic ejector SBP is delivered as a ready-to-connect product.

Available spare parts: silencer

Available accessories: mounting plate, mounting set

## Ordering Data Basic Ejectors SBP

Type*	G01	G02	G03	S01	S02	S03
SBP 05	10.02.01.00599	-	-	10.02.01.00563	-	-
SBP 07	10.02.01.00600	-	-	10.02.01.00564	-	-
SBP 10	-	10.02.01.00601	-	-	10.02.01.00565	-
SBP 15	-	10.02.01.00602	-	-	10.02.01.00566	-
SBP 20	-	-	10.02.01.00603	-	-	10.02.01.00567
SBP 25	-	-	10.02.01.00604	-	-	10.02.01.00568

\*Connection geometry: see design data of basic ejectors SBP

## Ordering Data Spare Parts Basic Ejectors SBP

Type	Spare Parts	Part no.
SBP 05	Silencer (round) SD M5-AG 9x24	10.02.01.00539
SBP 07	Silencer (round) SD M5-AG 9x24	10.02.01.00539
SBP 10	Silencer (round) SD G1/8-AG 14x40	10.02.01.00540
SBP 15	Silencer (round) SD G1/8-AG 14x40	10.02.01.00540
SBP 20	Silencer (round) SD G3/8-AG 20x76 SBP	10.02.01.00719

## Ordering Data Accessories Basic Ejectors SBP

Type	Mounting plate	Mounting set
SBP	10.02.01.00511	10.02.01.00769

Suction rate from 8 l/min to 215 l/min



## Technical Data Basic Ejectors SBP

Type	Nozzle diameter [mm]	Degree of evacuation [%]	Suction rate (max.) [l/min]	Suction rate (max.) [m³/h]	Air consumption suction [l/min]*	Air consumption suction [m³/h]**	Noise level suction [dB(A)]
SBP 05	0.5	85	8.0	0.5	14	0.8	53
SBP 07	0.7	85	16.0	1.0	22	1.3	59
SBP 10	1.0	85	37.7	2.3	48	2.9	59
SBP 15	1.5	85	71.0	4.3	105	6.3	65
SBP 20	2.0	85	127.0	7.6	197	11.8	68
SBP 25	2.5	85	215.0	12.9	311	18.7	70

\*At optimal operating pressure

\*\*At optimal operating pressure

Type	Noise level free [dB(A)]	Pressure range (operating pressure) [bar]	Recomm. internal hose diameter compressed air [mm]*	Recomm. internal hose diameter vacuum [mm]**	Weight [g]	Operating temperature [°C]
SBP 05	58	3.0 ... 6.0	2	2	7.5	0 ... 60
SBP 07	65	3.0 ... 6.0	2	2	7.5	0 ... 60
SBP 10	65	3.0 ... 6.0	4	6	22.0	0 ... 60
SBP 15	72	3.0 ... 6.0	4	6	22.0	0 ... 60
SBP 20	77	3.0 ... 6.0	6	7	50.0	0 ... 60
SBP 25	78	3.0 ... 6.0	6	7	50.0	0 ... 60

\*For max. length 2 m

\*\*For max. length 2 m



## Performance Data Basic Ejectors SBP

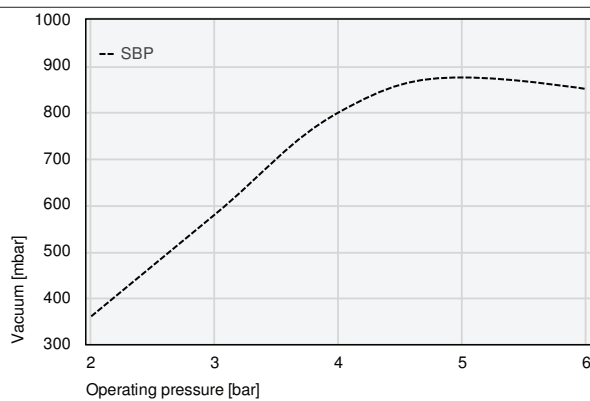

Achievable vacuum at various operating pressures

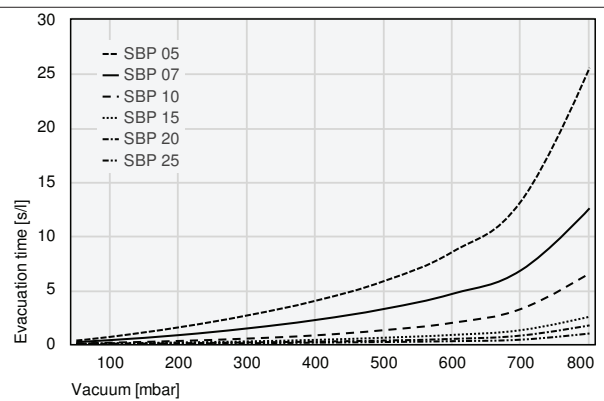

Evacuation times for various vacuum ranges [s/l]

# Basic Ejectors SBP

Suction rate from 8 l/min to 215 l/min

- Schmalz – The Company
- Vacuum Suction Cups
- Special Grippers
- Gripping Systems
- Clamping Systems
- Mounting Elements
- Vacuum Generators
- Valve Technology
- Switches and Monitoring
- Filters and Connections
- Services
- Contact
- Glossary
- Index of Products

## Performance Data Basic Ejectors SBP

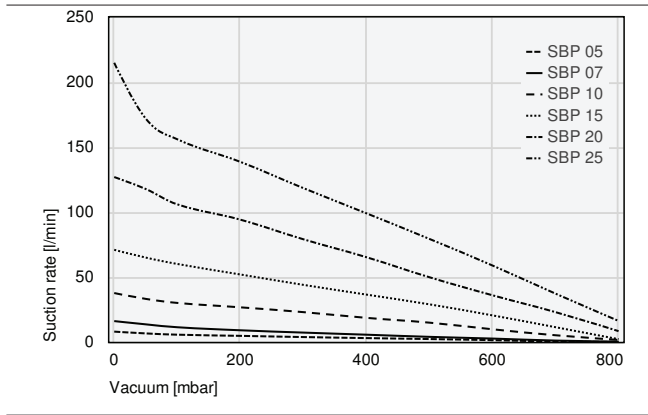

Suction capacity at various degrees of evacuation [l/min]

## Evacuation times for various vacuum ranges [s/l]

	50	100	200	300	400	500	600	700	800
SBP 05	0.34	0.68	1.56	2.66	4.02	5.84	8.54	13.22	25.54
SBP 07	0.20	0.38	0.84	1.46	2.24	3.26	4.66	6.84	12.56
SBP 10	0.06	0.14	0.30	0.52	0.82	1.30	1.98	3.26	6.56
SBP 15	0.05	0.08	0.16	0.26	0.40	0.60	0.86	1.30	2.54
SBP 20	0.03	0.05	0.09	0.16	0.24	0.34	0.49	0.80	1.74
SBP 25	0.03	0.04	0.07	0.09	0.14	0.20	0.28	0.42	0.99

## Suction capacity at various degrees of evacuation [l/min]

	0	50	100	200	300	400	500	600	700	800
SBP 05	8.00	6.62	5.64	4.74	3.81	3.01	2.28	1.42	0.40	0.10
SBP 07	16.10	13.60	11.37	9.03	7.25	5.63	3.97	2.65	1.10	0.30
SBP 10	37.70	33.20	30.10	26.70	23.00	18.60	14.90	9.80	5.20	1.61
SBP 15	71.00	65.00	60.10	52.00	44.00	36.50	29.00	20.50	11.40	2.18
SBP 20	127.00	117.80	106.00	94.20	79.10	65.30	49.87	35.99	23.00	8.36
SBP 25	215.00	172.00	156.10	138.70	118.50	99.10	79.36	58.90	37.24	16.24



# Basic Ejectors SBP

Suction rate from 8 l/min to 215 l/min



## Design Data Basic Ejectors SBP

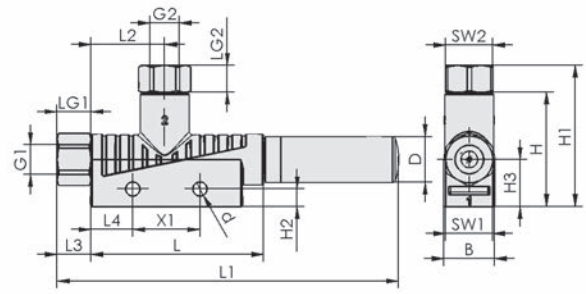
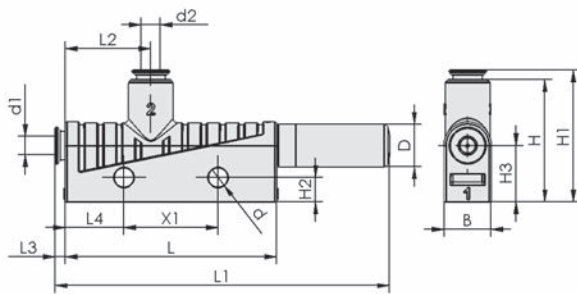

SBP S01 - S03

SBP G01 - G03

Type	B [mm]	d [mm]	d1 [mm]	d2 [mm]	D [mm]	G1	G2	H [mm]	H1 [mm]	H2 [mm]	H3 [mm]
SBP 05 G01	10	4.2	-	-	9	M5-F	M5-F	26	31.0	5.2	12
SBP 07 G01	10	4.2	-	-	9	M5-F	M5-F	26	31.0	5.2	12
SBP 10 G02	15	4.2	-	-	14	G1/8"-F	G1/8"-F	34	42.0	5.2	14
SBP 15 G02	15	4.2	-	-	14	G1/8"-F	G1/8"-F	34	42.0	5.2	14
SBP 20 G03	20	4.2	-	-	20	G1/4"-F	G3/8"-F	39	53.5	5.2	17
SBP 25 G03	20	4.2	-	-	20	G1/4"-F	G3/8"-F	39	53.5	5.2	17
SBP 05 S01	10	4.2	4	4	9	-	-	26	28.0	5.2	12
SBP 07 S01	10	4.2	4	4	9	-	-	26	28.0	5.2	12
SBP 10 S02	15	4.2	6	8	14	-	-	34	40.0	5.2	14
SBP 15 S02	15	4.2	6	8	14	-	-	34	40.0	5.2	14
SBP 20 S03	20	4.2	8	10	20	-	-	39	45.5	5.2	17
SBP 25 S03	20	4.2	8	10	20	-	-	39	45.5	5.2	17

Type	L [mm]	L1 [mm]	L2 [mm]	L3 [mm]	L4 [mm]	LG1 [mm]	LG2 [mm]	SW1 [mm]	SW2 [mm]	X1 [mm]
SBP 05 G01	45.0	74	18.0	5.0	12.5	5	5	8	8	20
SBP 07 G01	45.0	74	18.0	5.0	12.5	5	5	8	8	20
SBP 10 G02	51.5	102	22.0	10.0	12.5	8	8	14	14	20
SBP 15 G02	51.5	102	22.0	10.0	12.5	8	8	14	14	20
SBP 20 G03	86.5	176	24.5	13.0	12.5	9	10	17	19	20
SBP 25 G03	86.5	176	24.5	13.0	12.5	9	10	17	19	20
SBP 05 S01	45.0	71	18.0	2.0	12.5	-	-	-	-	20
SBP 07 S01	45.0	71	18.0	2.0	12.5	-	-	-	-	20
SBP 10 S02	51.5	97	22.0	5.5	12.5	-	-	-	-	20
SBP 15 S02	51.5	97	22.0	5.5	12.5	-	-	-	-	20
SBP 20 S03	86.5	168	24.5	5.5	12.5	-	-	-	-	20
SBP 25 S03	86.5	168	24.5	5.5	12.5	-	-	-	-	20

# Basic Ejectors SBP-C with Additional Functions

Suction rate from 7 l/min to 215 l/min



## Suitability for Industry Specific Applications

### Applications

- Basic ejector with plastic housing, integrated valve technology and system monitoring for use in very high dynamic feeder systems
- Handling of all kinds of airtight components
- For use in separating systems where space is restricted
- Construction of ejector blocks for centralized or decentralized individual control of suction cups



Basic Ejectors SBP-C with Additional Functions

### Design

- Ejector with single stage nozzle, available in six power ratings, from 0.5 to 2.5 mm nozzle diameter incl. silencer (3)
- Housing made of light, impact resistant plastic
- Connection of compressed air (6) and vacuum (2) with push-in coupling or threads
- Basic housing with connection facility for a vacuum switch
- Optionally available with suction (7) or blow off pulse (8), blow off reservoir (5) (on SBP-C 05 and 07) and vacuum switch (1)
- Can be fixed horizontal with mounting holes (4) or vertical with the base on a mounting plate

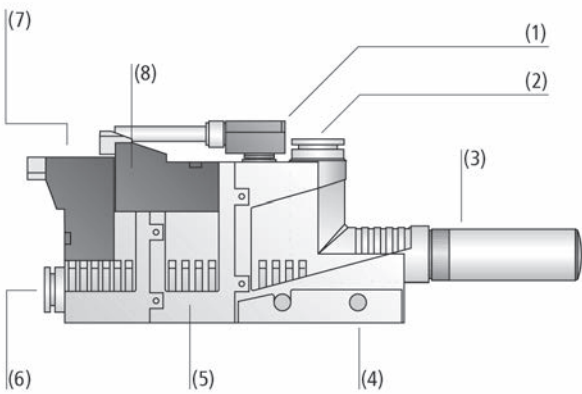

System Design Basic Ejectors SBP-C with Additional Functions

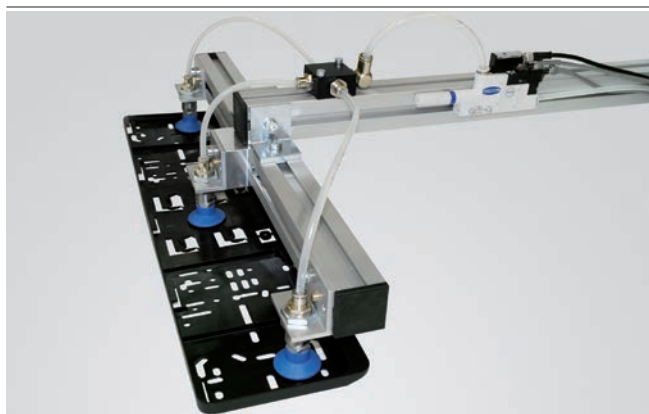

Central vacuum generation with basic ejector SBP-C for handling plastic injection molded parts

### Our Highlights...

- Plastic housing optimized in weight
- Ejector nozzles with six different power ratings
- Connections either with threaded holes or push-in couplings
- Integrated valve technology and vacuum monitoring

### Your Benefits...

- Ideal for decentralized vacuum generation in highly dynamic processes
- Various power ratings for optimized air consumption
- Space saving and easy to install
- The complete solution for optimized cycle times



Schmalz – The Company  
Vacuum Suction Cups  
Special Grippers  
Gripping Systems  
Clamping Systems  
Mounting Elements  
Vacuum Generators  
Valve Technology  
Switches and Monitoring  
Filters and Connections  
Services  
Contact  
Glossary  
Index of Products

# Basic Ejectors SBP-C with Additional Functions

Suction rate from 7 l/min to 215 l/min



## Designation Code Basic Ejectors SBP-C with Additional Functions



### 1 – Abbreviated designation

Code	Version
SBP-C	SBP-C

### 2 – Nozzle size

Code	Diameter in mm
05...25	ø 0.5 to 2.5

### 3 – Connection

Code	Connection
G01	Connection thread 1
G02	Connection thread 2
G03	Connection thread 3
S01	Quick connect push-in coupling 1
S02	Quick connect push-in coupling 2
S03	Quick connect push-in coupling 3

### 4 – Idle position suction valve

Code	Type
NC	Normally closed
NO	Normally open

### 5 – Blow off valve

Code	Type
A	Blow off valve
AI	Blow off pulse

### 6 – System monitoring

Code	Type
VS-T	Vacuum switch with teach button (PNP)

The basic ejector SBP-C is delivered as a ready-to-connect product (without connection cable).

Available spare parts: silencer

Available accessories: mounting plate, mounting set, connection cable



## Ordering Data Basic Ejectors SBP-C with Additional Functions

Type					Nozzle size:					
					05	07	10	15	20	25
SBP-C	G01	NC	-	-	10.02.01.00611	10.02.01.00612	-	-	-	-
SBP-C	G01	NC	AI	-	10.02.01.00623	10.02.01.00624	-	-	-	-
SBP-C	G01	NC	AI	VS-T	10.02.01.01005	10.02.01.01006	-	-	-	-
SBP-C	G01	NC	-	VS-T	10.02.01.01003	10.02.01.01004	-	-	-	-
SBP-C	G01	-	-	VS-T	10.02.01.00997	10.02.01.00998	-	-	-	-
SBP-C	S01	NC	-	-	10.02.01.00575	10.02.01.00576	-	-	-	-
SBP-C	S01	NC	AI	-	10.02.01.00587	10.02.01.00588	-	-	-	-
SBP-C	S01	NC	AI	VS-T	10.02.01.00989	10.02.01.00990	-	-	-	-
SBP-C	S01	NC	-	VS-T	10.02.01.00987	10.02.01.00988	-	-	-	-
SBP-C	S01	-	-	VS-T	10.02.01.00981	10.02.01.00982	-	-	-	-
SBP-C	G02	NO	A	-	-	-	10.02.01.00625	10.02.01.00626	-	-
SBP-C	G02	NO	A	VS-T	-	-	10.02.01.01008	10.02.01.01009	-	-
SBP-C	G02	-	-	VS-T	-	-	10.02.01.00999	10.02.01.01000	-	-
SBP-C	S02	NO	A	-	-	-	10.02.01.00589	10.02.01.00590	-	-
SBP-C	S02	NO	A	VS-T	-	-	10.02.01.00993	10.02.01.00994	-	-
SBP-C	S02	-	-	VS-T	-	-	10.02.01.00983	10.02.01.00984	-	-
SBP-C	G03	NO	A	-	-	-	-	-	10.02.01.00627	10.02.01.00628
SBP-C	G03	NO	A	VS-T	-	-	-	-	10.02.01.01010	10.02.01.01011
SBP-C	G03	-	-	VS-T	-	-	-	-	10.02.01.01001	10.02.01.01002
SBP-C	S03	NO	A	-	-	-	-	-	10.02.01.00591	10.02.01.00592
SBP-C	S03	NO	A	VS-T	-	-	-	-	10.02.01.00995	10.02.01.00996
SBP-C	S03	-	-	VS-T	-	-	-	-	10.02.01.00985	10.02.01.00986



Schmalz – The Company  
Vacuum Suction Cups  
Special Grippers  
Gripping Systems  
Clamping Systems  
Mounting Elements  
Vacuum Generators  
Valve Technology  
Switches and Monitoring  
Filters and Connections  
Services  
Contact  
Glossary  
Index of Products

# Basic Ejectors SBP-C with Additional Functions

Suction rate from 7 l/min to 215 l/min



## Ordering Data Spare Parts Basic Ejectors SBP-C with Additional Functions

Type	Spare Parts			Part no.
SBP-C 05	Silencer (round)	SD M5-AG 9x24		10.02.01.00539
SBP-C 07	Silencer (round)	SD M5-AG 9x24		10.02.01.00539
SBP-C 10	Silencer (round)	SD G1/8-AG 14x40		10.02.01.00540
SBP-C 15	Silencer (round)	SD G1/8-AG 14x40		10.02.01.00540
SBP-C 20	Silencer (round)	SD G3/8-AG 20x76 SBP		10.02.01.00719
SBP-C 25	Silencer (round)	SD G3/8-AG 20x76 SBP		10.02.01.00719



## Ordering Data Accessories Basic Ejectors SBP-C with Additional Functions

Type	Part no.	
Mounting plate	BEF-PL 110x44.5x3 SBP	10.02.01.00511
Mounting set	SET SBP M4-IG	10.02.01.00769
Connection cable for solenoid valves, 3 m, PUR	ASK B-MIC10 3000 K-2P	21.04.06.00086
Connection cable, M8 4-pole, 5 m, PUR, straight	ASK B-M8-4 5000 K-4P	10.06.02.00031



## Technical Data Basic Ejectors SBP-C with Additional Functions

Type*	Nozzle diameter [mm]	Degree of evacuation [%]	Suction rate (max.) [l/min]	Suction rate (max.) [m³/h]	Air consumption suction [l/min]**	Air consumption suction [m³/h]
SBP-C 05	0.5	85	7	0.4	14	0.8
SBP-C 07	0.7	85	16	1.0	24	1.5
SBP-C 10	1.0	85	38	2.3	48	2.9
SBP-C 15	1.5	85	70	4.2	118	7.1
SBP-C 20	2.0	85	123	7.4	208	12.5
SBP-C 25	2.5	85	215	12.9	311	18.7

\*The supply voltage for vacuum switches and solenoid valves is 24 VDC

\*\*On version with solenoid valves SBP-C 07 (24) / SBP-C 25 (320) and optimal operating pressure

Type*	Noise level suction [dB(A)]	Noise level free [dB(A)]	Pressure range (operating pressure) [bar]	Recomm. internal hose diameter compressed air [mm]**	Recomm. internal hose diameter vacuum [mm]***	Operating temperature [°C]
SBP-C 05	53	58	3.0 ... 6.0	2	2	0 ... 50
SBP-C 07	59	65	3.0 ... 6.0	2	2	0 ... 50
SBP-C 10	59	65	3.0 ... 6.0	4	6	0 ... 50
SBP-C 15	65	72	3.0 ... 6.0	4	6	0 ... 50
SBP-C 20	68	77	3.0 ... 6.0	6	7	0 ... 50
SBP-C 25	70	78	3.0 ... 6.0	6	7	0 ... 50

\*The supply voltage for vacuum switches and solenoid valves is 24 VDC

\*\*For max. length 2 m

\*\*\*For max. length 2 m



# Basic Ejectors SBP-C with Additional Functions

Suction rate from 7 l/min to 215 l/min



## Performance Data Basic Ejectors SBP-C with Additional Functions

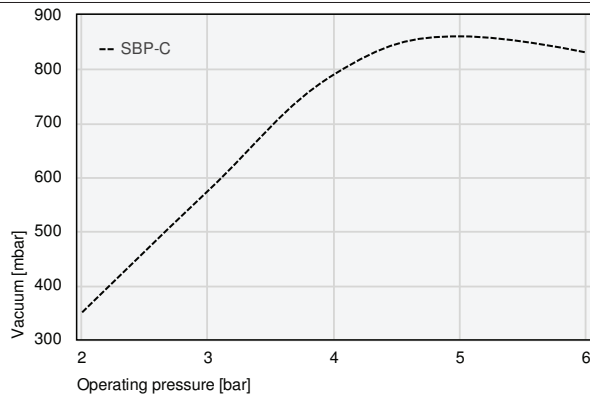

Achievable vacuum at various operating pressures

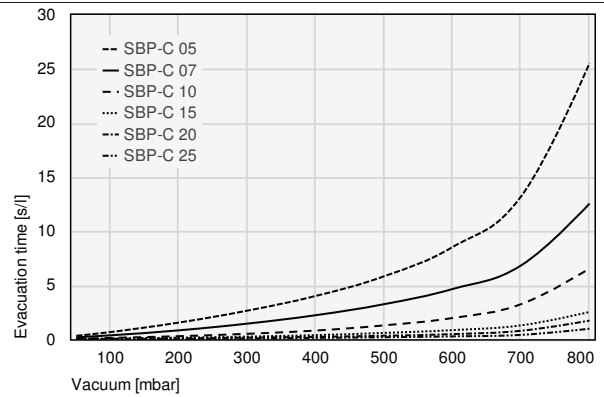

Evacuation times for various vacuum ranges [s/l]

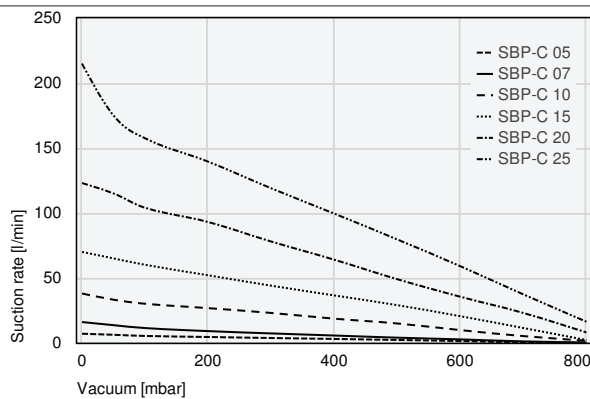

Suction capacity at various degrees of evacuation [l/min]



## Evacuation times for various vacuum ranges [s/l]

	50	100	200	300	400	500	600	700	800
SBP-C 05	0.34	0.68	1.56	2.66	4.02	5.84	8.54	13.22	25.54
SBP-C 07	0.20	0.38	0.84	1.46	2.24	3.26	4.66	6.84	12.56
SBP-C 10	0.06	0.14	0.30	0.52	0.82	1.30	1.98	3.26	6.56
SBP-C 15	0.05	0.08	0.16	0.26	0.40	0.60	0.86	1.30	2.54
SBP-C 20	0.03	0.05	0.09	0.16	0.24	0.34	0.49	0.80	1.74
SBP-C 25	0.02	0.03	0.06	0.09	0.14	0.20	0.28	0.42	0.99



## Suction capacity at various degrees of evacuation [l/min]

	0	50	100	200	300	400	500	600	700	800
SBP-C 05	7.00	6.20	5.30	4.50	3.70	3.00	2.20	1.40	0.40	0.10
SBP-C 07	16.00	13.60	11.37	9.03	7.25	5.63	3.97	2.65	1.10	0.30
SBP-C 10	38.00	33.20	30.10	26.70	23.00	18.60	14.90	9.80	5.20	1.61
SBP-C 15	70.00	65.00	60.10	52.00	44.00	36.50	29.00	20.50	11.40	2.18
SBP-C 20	123.00	115.00	104.00	93.00	78.00	64.00	49.00	35.50	23.00	8.00
SBP-C 25	215.00	175.00	157.50	139.50	119.00	99.50	79.60	59.00	37.30	16.30

# Basic Ejectors SBP-C with Additional Functions

Suction rate from 7 l/min to 215 l/min



## Design Data Basic Ejectors SBP-C with Additional Functions

Schmalz - The Company  
Vacuum Suction Cups  
Special Grippers  
Gripping Systems  
Clamping Systems  
Mounting Elements  
Vacuum Generators  
Valve Technology  
Switches and Monitoring  
Filters and Connections  
Services  
Contact  
Glossary  
Index of Products

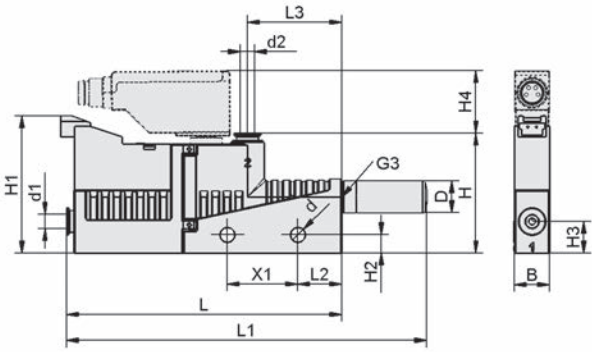

SBP-C 05/07 S01 NC (VS-T)

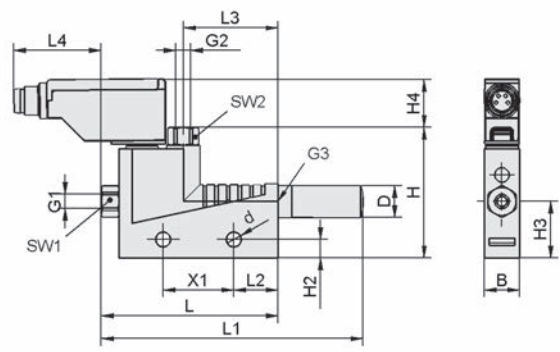

SBP-C 05/07 G01 VS-T, 10/15 G02 VS-T, 20/25 G03 VS-T

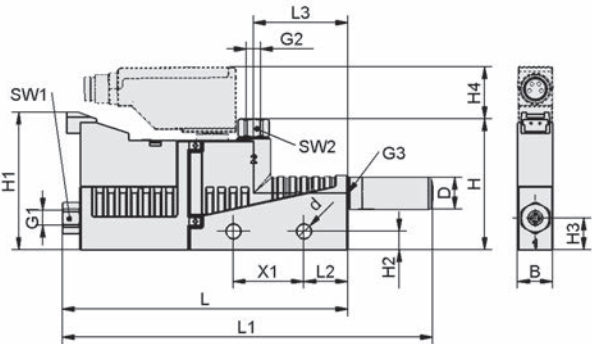

SBP-C 05/07 G01 NC (VS-T)

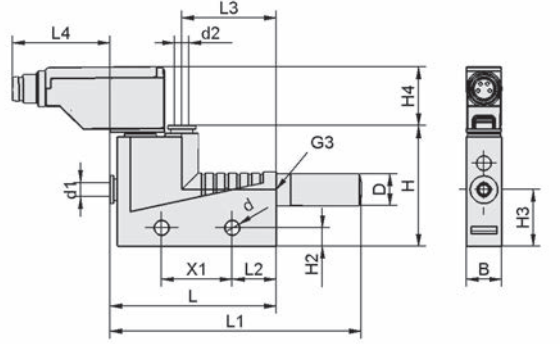

SBP-C 05/07 S01 VS-T, 10/15 S02 VS-T, 20/25 S03 VS-T

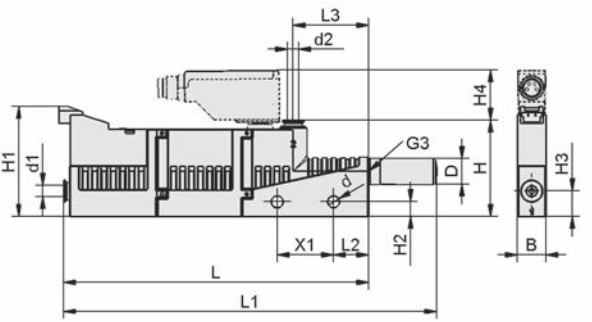

SBP-C 05/07 S01 NC AI (VS-T)

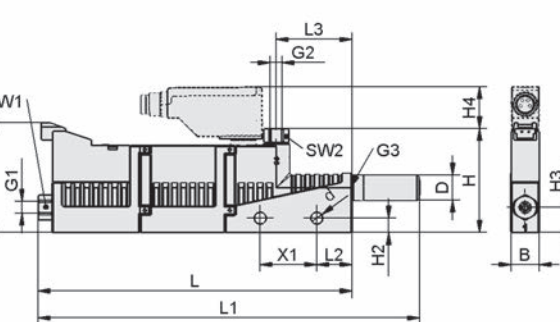

SBP-C 05/07 G01 NC AI (VS-T)

# Basic Ejectors SBP-C with Additional Functions

Suction rate from 7 l/min to 215 l/min



## Design Data Basic Ejectors SBP-C with Additional Functions

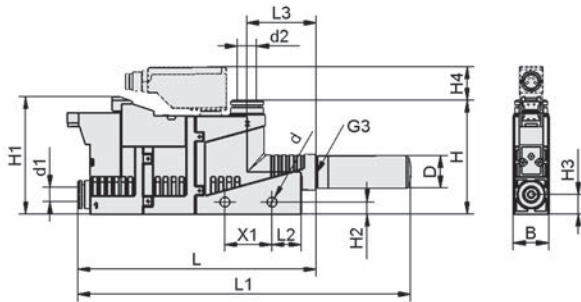

SBP-C 10/15 S02 NO A (VS-T)

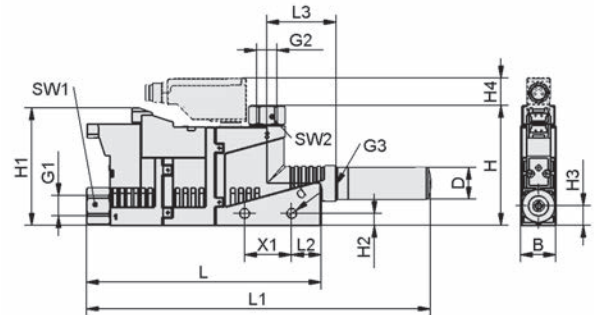

SBP-C 10/15 G02 NO A (VS-T)

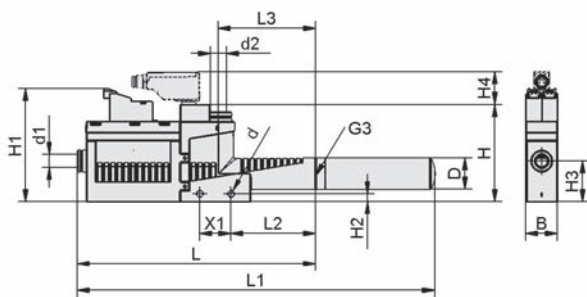

SBP-C 20/25 S03 NO A (VS-T)

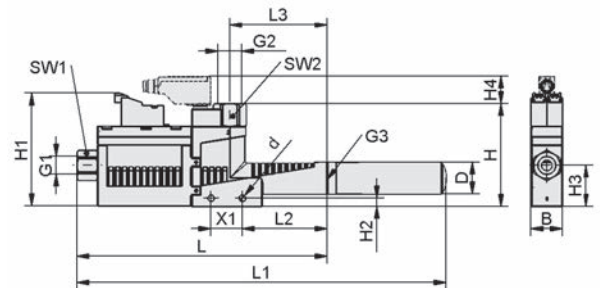

SBP-C 20/25 G03 NO A (VS-T)

Type	B [mm]	d [mm]	d1 [mm]	d2 [mm]	D [mm]	G1	G2	G3	H [mm]	H1 [mm]	H2 [mm]
SBP-C 05 G01 NC	10	4.2	-	-	9	M5-F	M5-F	M5-F	37	39	5.2
SBP-C 05 G01 NC AI	10	4.2	-	-	9	M5-F	M5-F	M5-F	37	39	5.2
SBP-C 05 G01 NC AI VS-T	10	4.2	-	-	9	M5-F	M5-F	M5-F	37	39	5.2
SBP-C 05 G01 NC VS-T	10	4.2	-	-	9	M5-F	M5-F	M5-F	37	39	5.2
SBP-C 05 G01 VS-T	10	4.2	-	-	9	M5-F	M5-F	M5-F	37	-	5.2
SBP-C 05 S01 NC	10	4.2	4	4	9	-	-	M5-F	34	39	5.2
SBP-C 05 S01 NC AI	10	4.2	4	4	9	-	-	M5-F	34	39	5.2
SBP-C 05 S01 NC AI VS-T	10	4.2	4	4	9	-	-	M5-F	34	39	5.2
SBP-C 05 S01 NC VS-T	10	4.2	4	4	9	-	-	M5-F	34	39	5.2
SBP-C 05 S01 VS-T	10	4.2	4	4	9	-	-	M5-F	34	-	5.2
SBP-C 07 G01 NC	10	4.2	-	-	9	M5-F	M5-F	M5-F	37	39	5.2
SBP-C 07 G01 NC AI	10	4.2	-	-	9	M5-F	M5-F	M5-F	37	39	5.2
SBP-C 07 G01 NC AI VS-T	10	4.2	-	-	9	M5-F	M5-F	M5-F	37	39	5.2
SBP-C 07 G01 NC VS-T	10	4.2	-	-	9	M5-F	M5-F	M5-F	37	39	5.2



Schmalz – The Company  
Vacuum Suction Cups  
Special Grippers  
Gripping Systems  
Clamping Systems  
Mounting Elements  
Vacuum Generators  
Valve Technology  
Switches and Monitoring  
Filters and Connections  
Services  
Contact  
Glossary  
Index of Products

# Basic Ejectors SBP-C with Additional Functions

Suction rate from 7 l/min to 215 l/min



## Design Data Basic Ejectors SBP-C with Additional Functions

Type	B [mm]	d [mm]	d1 [mm]	d2 [mm]	D [mm]	G1	G2	G3	H [mm]	H1 [mm]	H2 [mm]
SBP-C 07 G01 VS-T	10	4.2	-	-	9	M5-F	M5-F	M5-F	37	-	5.2
SBP-C 07 S01 NC	10	4.2	4	4	9	-	-	M5-F	34	39	5.2
SBP-C 07 S01 NC AI	10	4.2	4	4	9	-	-	M5-F	34	39	5.2
SBP-C 07 S01 NC AI VS-T	10	4.2	4	4	9	-	-	M5-F	34	39	5.2
SBP-C 07 S01 NC VS-T	10	4.2	4	4	9	-	-	M5-F	34	39	5.2
SBP-C 07 S01 VS-T	10	4.2	4	4	9	-	-	M5-F	34	-	5.2
SBP-C 10 G02 NO A	15	4.2	-	-	14	G1/8"-F	G1/8"-F	G1/8"-F	51	50	5.2
SBP-C 10 G02 NO A VS-T	15	4.2	-	-	14	G1/8"-F	G1/8"-F	G1/8"-F	51	50	5.2
SBP-C 10 G02 VS-T	15	4.2	-	-	14	G1/8"-F	G1/8"-F	G1/8"-F	51	-	5.2
SBP-C 10 S02 NO A	15	4.2	6	8	14	-	-	G1/8"-F	49	50	5.2
SBP-C 10 S02 NO A VS-T	15	4.2	6	8	14	-	-	G1/8"-F	49	50	5.2
SBP-C 10 S02 VS-T	15	4.2	6	8	14	-	-	G1/8"-F	49	-	5.2
SBP-C 15 G02 NO A	15	4.2	-	-	14	G1/8"-F	G1/8"-F	G1/8"-F	51	50	5.2
SBP-C 15 G02 NO A VS-T	15	4.2	-	-	14	G1/8"-F	G1/8"-F	G1/8"-F	51	50	5.2
SBP-C 15 G02 VS-T	15	4.2	-	-	14	G1/8"-F	G1/8"-F	G1/8"-F	51	-	5.2
SBP-C 15 S02 NO A	15	4.2	6	8	14	-	-	G1/8"-F	49	50	5.2
SBP-C 15 S02 NO A VS-T	15	4.2	6	8	14	-	-	G1/8"-F	49	50	5.2
SBP-C 15 S02 VS-T	15	4.2	6	8	14	-	-	G1/8"-F	49	-	5.2
SBP-C 20 G03 NO A	20	4.2	-	-	20	G1/4"-F	G3/8"-F	G3/8"-F	66	72	5.2
SBP-C 20 G03 NO A VS-T	20	4.2	-	-	20	G1/4"-F	G3/8"-F	G3/8"-F	66	72	5.2
SBP-C 20 G03 VS-T	20	4.2	-	-	20	G1/4"-F	G3/8"-F	G3/8"-F	66	-	5.2
SBP-C 20 S03 NO A	20	4.2	8	10	20	-	-	G3/8"-F	58	72	5.2
SBP-C 20 S03 NO A VS-T	20	4.2	8	10	20	-	-	G3/8"-F	62	72	5.2
SBP-C 20 S03 VS-T	20	4.2	8	10	20	-	-	G3/8"-F	62	-	5.2
SBP-C 25 G03 NO A	20	4.2	-	-	20	G1/4"-F	G3/8"-F	G3/8"-F	66	72	5.2
SBP-C 25 G03 NO A VS-T	20	4.2	-	-	20	G1/4"-F	G3/8"-F	G3/8"-F	66	72	5.2
SBP-C 25 G03 VS-T	20	4.2	-	-	20	G1/4"-F	G3/8"-F	G3/8"-F	66	-	5.2
SBP-C 25 S03 NO A	20	4.2	8	10	20	-	-	G3/8"-F	58	72	5.2
SBP-C 25 S03 NO A VS-T	20	4.2	8	10	20	-	-	G3/8"-F	62	72	5.2
SBP-C 25 S03 VS-T	20	4.2	8	10	20	-	-	G3/8"-F	62	-	5.2

Type	H3 [mm]	H4 [mm]	L [mm]	L1 [mm]	L2 [mm]	L3 [mm]	L4 [mm]	SW1 [mm]	SW2 [mm]	X1 [mm]
SBP-C 05 G01 NC	9	-	81	105	13	27	-	8	8	20
SBP-C 05 G01 NC AI	9	-	111	135	13	27	-	8	8	20
SBP-C 05 G01 NC AI VS-T	9	15	111	135	13	27	-	8	8	20
SBP-C 05 G01 NC VS-T	9	15	81	105	13	27	-	8	8	20
SBP-C 05 G01 VS-T	16	15	50	74	13	27	25	8	8	20
SBP-C 05 S01 NC	9	-	78	102	13	27	-	-	-	20
SBP-C 05 S01 NC AI	9	-	108	132	13	27	-	-	-	20
SBP-C 05 S01 NC AI VS-T	9	18	108	132	13	27	-	-	-	20
SBP-C 05 S01 NC VS-T	9	18	78	102	13	27	-	-	-	20
SBP-C 05 S01 VS-T	16	18	47	71	13	27	28	-	-	20
SBP-C 07 G01 NC	9	-	81	105	13	27	-	8	8	20
SBP-C 07 G01 NC AI	9	-	111	135	13	27	-	8	8	20
SBP-C 07 G01 NC AI VS-T	9	15	111	135	13	27	-	8	8	20
SBP-C 07 G01 NC VS-T	9	15	81	105	13	27	-	8	8	20

Schmalz – The Company  
Vacuum Suction Cups  
Special Grippers  
Gripping Systems  
Clamping Systems  
Mounting Elements  
Vacuum Generators  
Valve Technology  
Switches and Monitoring  
Filters and Connections  
Services  
Contact  
Glossary  
Index of Products

# Basic Ejectors SBP-C with Additional Functions

Suction rate from 7 l/min to 215 l/min



## Design Data Basic Ejectors SBP-C with Additional Functions

Type	H3 [mm]	H4 [mm]	L [mm]	L1 [mm]	L2 [mm]	L3 [mm]	L4 [mm]	SW1 [mm]	SW2 [mm]	X1 [mm]
SBP-C 07 G01 VS-T	16	15	50	74	13	27	25	8	8	20
SBP-C 07 S01 NC	9	-	78	102	13	27	-	-	-	20
SBP-C 07 S01 NC AI	9	-	108	132	13	27	-	-	-	20
SBP-C 07 S01 NC AI VS-T	9	18	108	132	13	27	-	-	-	20
SBP-C 07 S01 NC VS-T	9	18	78	102	13	27	-	-	-	20
SBP-C 07 S01 VS-T	16	18	47	71	13	27	28	-	-	20
SBP-C 10 G02 NO A	9	-	106	146	19	30	-	14	14	20
SBP-C 10 G02 NO A VS-T	9	12	106	146	19	30	-	14	14	20
SBP-C 10 G02 VS-T	18	12	62	102	19	30	20	14	14	20
SBP-C 10 S02 NO A	9	-	102	142	19	30	-	-	-	20
SBP-C 10 S02 NO A VS-T	9	15	102	142	13	30	-	-	-	20
SBP-C 10 S02 VS-T	18	15	57	97	19	30	25	-	-	20
SBP-C 15 G02 NO A	9	-	106	146	19	30	-	14	14	20
SBP-C 15 G02 NO A VS-T	9	12	106	146	19	30	-	14	14	20
SBP-C 15 G02 VS-T	18	12	62	102	19	30	20	14	14	20
SBP-C 15 S02 NO A	9	-	102	142	19	30	-	-	-	20
SBP-C 15 S02 NO A VS-T	9	15	102	142	19	30	-	-	-	20
SBP-C 15 S02 VS-T	18	15	57	97	19	30	25	-	-	20
SBP-C 20 G03 NO A	9	-	160	236	54	62	-	17	19	20
SBP-C 20 G03 NO A VS-T	26	18	160	236	54	62	-	17	19	20
SBP-C 20 G03 VS-T	18	18	100	176	54	62	18	17	19	20
SBP-C 20 S03 NO A	26	-	152	228	54	62	-	-	-	20
SBP-C 20 S03 NO A VS-T	26	21	152	228	54	62	-	-	-	20
SBP-C 20 S03 VS-T	18	21	92	168	54	62	26	-	-	20
SBP-C 25 G03 NO A	9	-	160	236	54	62	-	17	19	20
SBP-C 25 G03 NO A VS-T	26	18	160	236	54	62	-	17	19	20
SBP-C 25 G03 VS-T	18	18	100	176	54	62	18	17	19	20
SBP-C 25 S03 NO A	26	-	152	228	54	62	-	-	-	20
SBP-C 25 S03 NO A VS-T	26	21	152	228	54	62	-	-	-	20
SBP-C 25 S03 VS-T	18	21	92	168	54	62	26	-	-	20

Schmalz –  
The Company

Vacuum  
Suction Cups

Special  
Grippers

Gripping  
Systems

Clamping  
Systems

Mounting  
Elements

Vacuum  
Generators

Valve  
Technology

Switches and  
Monitoring

Filters and  
Connections

Services

Contact

Glossary

Index of  
Products



# Basic Ejectors SBP-HV/HF

Suction rate up to 309 l/min

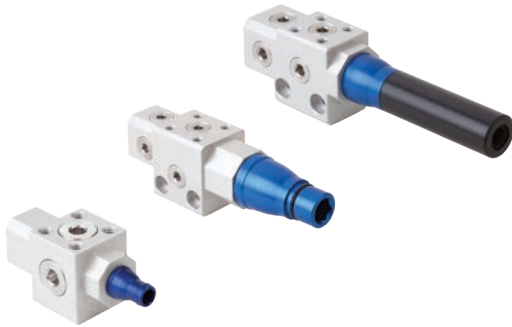

Basic Ejectors SBP-HV/HF

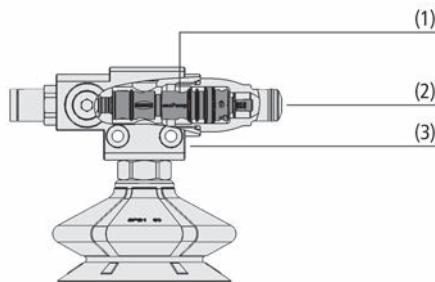

System Design Basic Ejectors SBP-HV/HF



Basic ejectors SBP-HV/HF handling cardboard boxes

## Suitability for Industry Specific Applications

### Applications

- Basic ejectors SBP-HV/HF for universal application in vacuum systems
- Integrated ejector module for energy efficient vacuum generation because of eco nozzle technology

### Design

- Lightweight, compact, integrated plastic ejector module (1)
- Available in three performance classes and two variants: optimized air consumption for airtight (HV) or porous (HF) materials (3)
- Assemblies available with and without silencer (2)

### Our Highlights...

- High suction capacity with low air consumption
- Use for airtight (HV) and porous (HF) workpieces
- Fast, with powerful vacuum
- Resistant to dirt

### Your Benefits...

- Energy efficient vacuum generation
- Fast and reliable product selection for each application
- Quickly reaches working vacuum; reliable compensation for leakage
- Long service intervals and simple, tool free cleaning



- Schmalz – The Company
- Vacuum Suction Cups
- Special Grippers
- Gripping Systems
- Clamping Systems
- Mounting Elements
- Vacuum Generators
- Valve Technology
- Switches and Monitoring
- Filters and Connections
- Services
- Contact
- Glossary
- Index of Products

# Basic Ejectors SBP-HV/HF

Suction rate up to 309 l/min



## Designation Code Basic Ejectors SBP-HV/HF

<b>SBP</b>	-	<b>HF</b>	-	<b>2</b>	-	<b>06</b>	-	<b>13</b>	-	<b>SD</b>
1		2		3		4		5		6

### 1 – Abbreviated designation

Code	Version
SBP	SBP

### 2 – Variant

Code	Type
HF	High Flow
HV	High Vacuum

### 3 – Nozzle technology

Code	Type
2	2 stage
3	3 stage

### 4 – Nozzle size

Code	Diameter in mm
03	Ø 0.3
04	Ø 0.4
06	Ø 0.6
07	Ø 0.7
13	Ø 1.3
16	Ø 1.6

### 5 – Hole

Code	Diameter in mm
7	Ø 7
13	Ø 13
22	Ø 22

### 6 – Product addition

Code	Type
SD	Silencer

The basic ejectors SBP-HV/HF is delivered as a ready-to-connect product.



## Ordering Data Basic Ejectors SBP-HV/HF

Type	Part no.
SBP HF 2 03 7	10.02.01.01715
SBP HF 2 06 13	10.02.01.01717
SBP HF 2 06 13 SD	10.02.01.01729
SBP HF 3 06 13	10.02.01.01720
SBP HF 3 06 13 SD	10.02.01.01732
SBP HF 2 13 22	10.02.01.01723
SBP HF 2 13 22 SD	10.02.01.01735
SBP HF 3 13 22	10.02.01.01726
SBP HF 3 13 22 SD	10.02.01.01738

Type	Part no.
SBP HV 2 04 7	10.02.01.01716
SBP HV 2 07 13	10.02.01.01718
SBP HV 2 07 13 SD	10.02.01.01730
SBP HV 3 07 13	10.02.01.01721
SBP HV 3 07 13 SD	10.02.01.01733
SBP HV 2 16 22	10.02.01.01724
SBP HV 2 16 22 SD	10.02.01.01736
SBP HV 3 16 22	10.02.01.01727
SBP HV 3 16 22 SD	10.02.01.01739



# Basic Ejectors SBP-HV/HF

Suction rate up to 309 l/min



## Ordering Data Basic Ejectors SBP-HV/HF

Type	Part no.*
SBP HV 2 07 13 S	10.02.01.01719
SBP HV 2 07 13 S SD	10.02.01.01731
SBP HV 3 07 13 S	10.02.01.01722
SBP HV 3 07 13 S SD	10.02.01.01734
SBP HV 2 16 22 S	10.02.01.01725
SBP HV 2 16 22 S SD	10.02.01.01737
SBP HV 3 16 22 S	10.02.01.01728
SBP HV 3 16 22 S SD	10.02.01.01740

\*Maintenance of the vacuum for airtight pieces using additional safety non-return valve. An active blow off impulse is required for release.



## Technical Data Basic Ejectors SBP-HV/HF

Type	Operating temperature [°C]	Degree of evacuation [%]	Recomm. internal hose diameter compressed air [mm]	Recomm. internal hose diameter vacuum [mm]	Pressure range (operating pressure) [bar]	Noise level free [dB(A)]	Noise level suction [dB(A)]	Weight [g]
SBP HF 2 03 7	0 ... 60	55	2	4	2.0 - 6.0	63	54	29
SBP HF 2 06 13	0 ... 60	70	4	6	2.0 ... 6.0	70	58	85
SBP HF 2 06 13 SD	0 ... 60	70	4	6	2.0 ... 6.0	67	56	91
SBP HF 3 06 13	0 ... 60	70	4	6	2.0 ... 6.0	68	57	90
SBP HF 3 06 13 SD	0 ... 60	70	4	6	2.0 ... 6.0	63	55	96
SBP HF 2 13 22	0 ... 60	61	6	12	2.0 ... 6.0	84	75	262
SBP HF 2 13 22 SD	0 ... 60	61	6	12	2.0 ... 6.0	76	63	277
SBP HF 3 13 22	0 ... 60	61	6	12	2.0 ... 6.0	81	73	280
SBP HF 3 13 22 SD	0 ... 60	61	6	12	2.0 ... 6.0	69	61	295
SBP HV 2 04 7	0 ... 60	79	2	4	2.0 ... 6.0	65	57	29
SBP HV 2 07 13	0 ... 60	85	4	6	2.0 ... 6.0	72	62	85
SBP HV 2 07 13 SD	0 ... 60	85	4	6	2.0 ... 6.0	68	57	91
SBP HV 3 07 13	0 ... 60	85	4	6	2.0 ... 6.0	70	61	90
SBP HV 3 07 13 SD	0 ... 60	85	4	6	2.0 ... 6.0	64	58	96
SBP HV 2 16 22	0 ... 60	90	6	12	2.0 ... 6.0	87	76	262
SBP HV 2 16 22 SD	0 ... 60	90	6	12	2.0 ... 6.0	77	63	277
SBP HV 3 16 22	0 ... 60	90	6	12	2.0 ... 6.0	80	72	280
SBP HV 3 16 22 SD	0 ... 60	90	6	12	2.0 ... 6.0	70	63	295
SBP HV 2 07 13 S	0 ... 60	85	4	6	2.0 ... 6.0	72	62	85
SBP HV 2 07 13 S SD	0 ... 60	85	4	6	2.0 ... 6.0	68	57	91
SBP HV 3 07 13 S	0 ... 60	85	4	6	2.0 ... 6.0	70	61	90
SBP HV 3 07 13 S SD	0 ... 60	85	4	6	2.0 ... 6.0	64	58	96
SBP HV 3 16 22 S	0 ... 60	90	6	12	2.0 ... 6.0	80	72	280
SBP HV 2 16 22 S SD	0 ... 60	90	6	12	2.0 ... 6.0	77	63	277
SBP HV 2 16 22 S	0 ... 60	90	6	12	2.0 ... 6.0	87	76	262
SBP HV 3 16 22 S SD	0 ... 60	90	6	12	2.0 ... 6.0	70	63	295





Suction rate up to 309 l/min



## Performance Data Basic Ejectors SBP-HV/HF

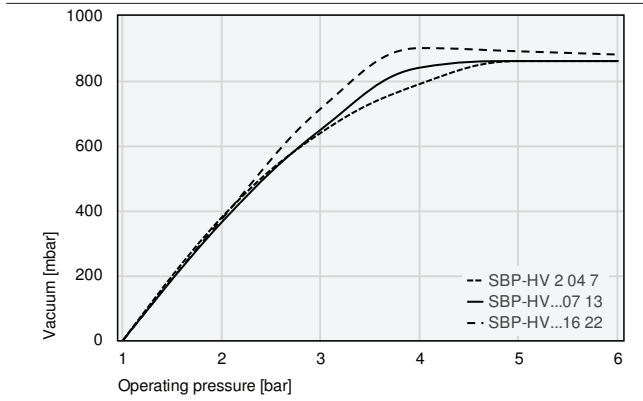

Achievable vacuum at various operating pressures

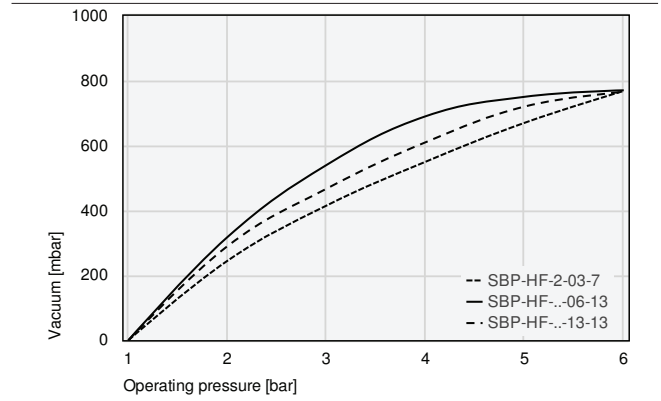

Achievable vacuum at various operating pressures

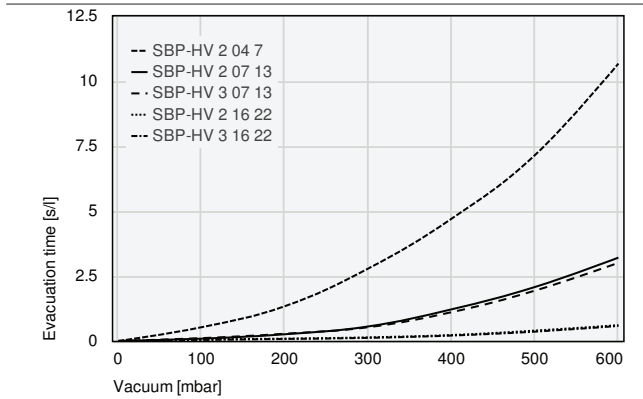

Evacuation times for various vacuum ranges [s/l]

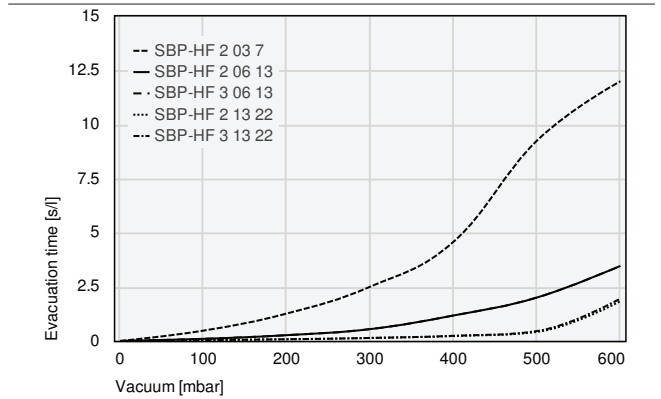

Evacuation times for various vacuum ranges [s/l]

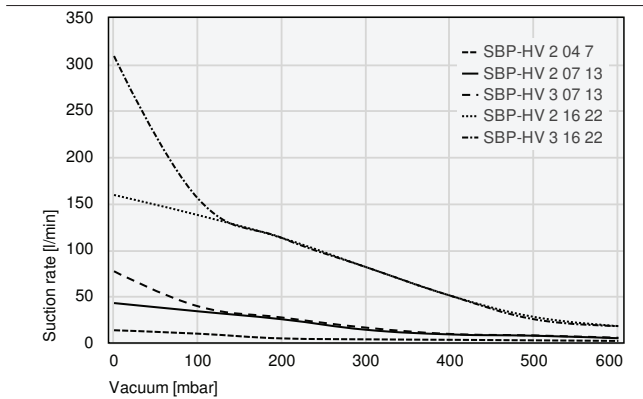

Suction capacity at various degrees of evacuation [l/min]

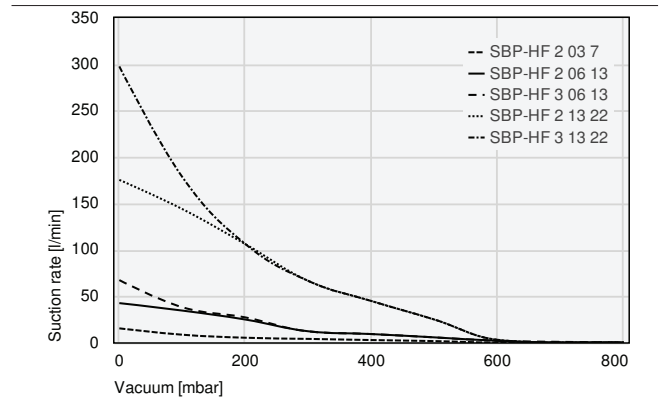

Suction capacity at various degrees of evacuation [l/min]

- Schmalz – The Company
- Vacuum Suction Cups
- Special Grippers
- Gripping Systems
- Clamping Systems
- Mounting Elements
- Vacuum Generators
- Valve Technology
- Switches and Monitoring
- Filters and Connections
- Services
- Contact
- Glossary
- Index of Products



# Basic Ejectors SBP-HV/HF

Suction rate up to 309 l/min



## Evacuation times for various vacuum ranges [s/l]

	100	200	300	400	500	600
SBP-HV 2 04 7	0.53	1.34	2.79	4.71	7.16	10.68
SBP-HV 2 07 13	0.09	0.26	0.56	1.22	2.08	3.21
SBP-HV 3 07 13	0.11	0.28	0.53	1.11	1.94	3.01
SBP-HV 2 16 22	0.06	0.09	0.14	0.23	0.40	0.61
SBP-HV 3 16 22	0.04	0.08	0.12	0.21	0.36	0.58

	100	200	300	400	500	600
SBP-HF 2 03 7	0.48	1.27	2.51	4.59	9.26	12.00
SBP-HF 2 06 13	0.10	0.27	0.55	1.18	2.01	3.47
SBP-HF 3 06 13	0.10	0.27	0.55	1.18	2.01	3.47
SBP-HF 2 13 22	0.04	0.08	0.14	0.23	0.42	1.84
SBP-HF 3 13 22	0.04	0.08	0.14	0.24	0.46	1.96



## Suction capacity at various degrees of evacuation [l/min]

	0	100	200	300	400	500	600
SBP-HV 2 04 7	13.2	9.5	4.4	3.4	2.9	2.3	1.7
SBP-HV 2 07 13	42.5	33.6	25.0	13.7	8.7	7.3	4.6
SBP-HV 3 07 13	76.8	39.0	26.9	16.0	9.2	7.6	5.1
SBP-HV 2 16 22	159.0	137.3	112.6	81.2	50.5	27.5	17.7
SBP-HV 3 16 22	308.8	155.0	112.6	81.2	50.5	25	17.7

	0	100	200	300	400	500	600	700
SBP-HF 2 03 7	15.3	8.4	5.1	3.9	2.6	1.5	-	-
SBP-HF 2 06 13	42.4	34.4	24.7	12.1	9.1	5.5	1.8	-
SBP-HF 3 06 13	67.3	38.0	27.0	12.0	9.1	5.5	1.8	0.7
SBP-HF 2 13 22	175.3	143.8	106.0	66.3	44.7	24.7	2.9	-
SBP-HF 3 13 22	297.6	178.3	106.1	66.3	44.7	24.7	2.9	-

# Basic Ejectors SBP-HV/HF

Suction rate up to 309 l/min



## Design Data Basic Ejectors SBP-HV/HF

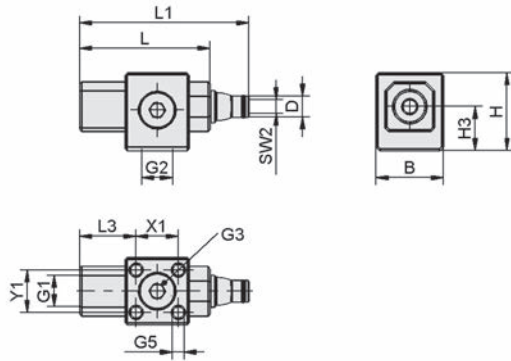

SBP 2 7

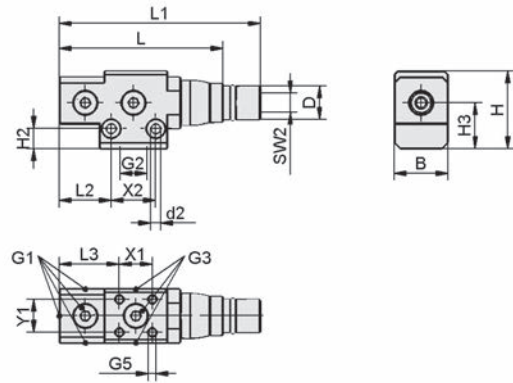

SBP 2 13, 3 13, 2 22, 3 22

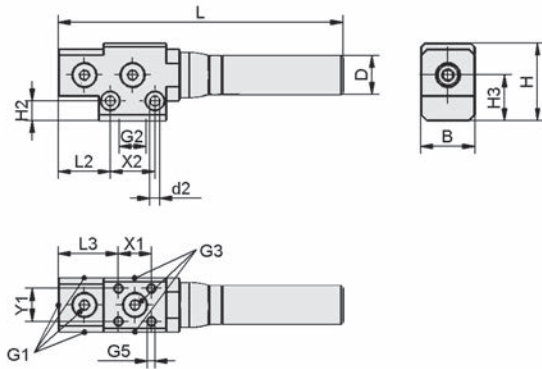

SBP SD

Type	B [mm]	D [mm]	d2 [mm]	G1	G2	G3	G5	H [mm]	H2 [mm]	H3 [mm]	L [mm]	L1 [mm]	L2 [mm]	L3 [mm]	SW2 [mm]	X1 [mm]	X2 [mm]	Y1 [mm]
SBP HF 2 03 7	19	6.0	-	G1/8"-F	G1/8"-F	G1/8"-F	M4-F	22	-	12.5	37.0	48	-	16.0	4	12	-	12
SBP HF 2 06 13	23	14.2	4.2	G1/8"-F	G1/4"-F	G1/8"-F	M4-F	33	8.5	19.5	69.5	86	22.0	25.5	8	14	19	14
SBP HF 2 06 13 SD	23	16.5	4.2	G1/8"-F	G1/4"-F	G1/8"-F	M4-F	33	8.5	19.5	121.0	-	22.0	25.5	-	14	19	14
SBP HF 3 06 13	23	14.2	4.2	G1/8"-F	G1/4"-F	G1/8"-F	M4-F	33	8.5	19.5	88.0	104	22.0	25.5	8	14	19	14
SBP HF 3 06 13 SD	23	16.5	4.2	G1/8"-F	G1/4"-F	G1/8"-F	M4-F	33	8.5	19.5	139.5	-	22.0	25.5	-	14	19	14
SBP HF 2 13 22	35	20.0	6.4	G1/4"-F	G3/8"-F	G1/4"-F	M6-F	44	9.5	25.5	120.5	139	32.5	34.5	12	22	26	22
SBP HF 2 13 22 SD	35	29.0	6.4	G1/4"-F	G3/8"-F	G1/4"-F	M6-F	44	9.5	25.5	190.5	-	32.5	34.5	-	22	26	22
SBP HF 3 13 22	35	20.0	6.4	G1/4"-F	G3/8"-F	G1/4"-F	M6-F	44	9.5	25.5	160.5	179	32.5	34.5	14	22	26	22
SBP HF 3 13 22 SD	35	29.0	6.4	G1/4"-F	G3/8"-F	G1/4"-F	M6-F	44	9.5	25.5	230.5	-	32.5	34.5	-	22	26	22

Schmalz – The Company  
Vacuum Suction Cups  
Special Grippers  
Gripping Systems  
Clamping Systems  
Mounting Elements  
Vacuum Generators  
Valve Technology  
Switches and Monitoring  
Filters and Connections  
Services  
Contact  
Glossary  
Index of Products



# Inline Ejectors SLP

Suction rate from 8 l/min to 16 l/min



## Suitability for Industry Specific Applications

### Applications

- Inline ejector for mounting directly in the hose line
- Handling of electronic components
- Vacuum generation in handling systems with restricted space
- Use in separation systems for plastic and sheet-metal machining



Inline Ejectors SLP

### Design

- Two piece housing made of light, impact resistant plastic (1)
- Axial connection of compressed air (3) and vacuum (2) with quick action push-in couplings for hose diameter 4 mm
- Vacuum generator with single nozzle in two power ratings, 0.5 and 0.7 mm diameter
- Air outlet with good flow characteristics
- Pleasing industrial design, only 10 mm thick



System Design Inline Ejectors SLP

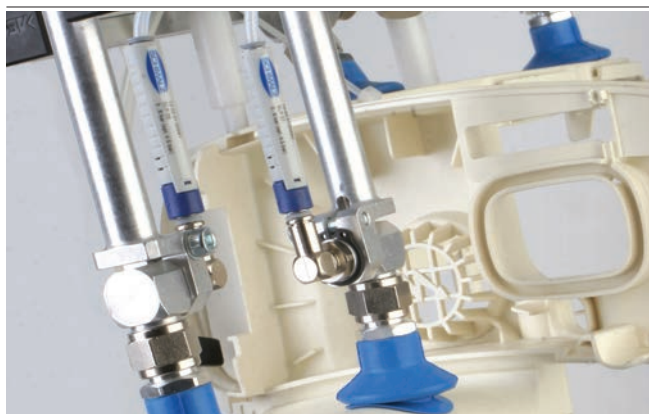

Decentralized vacuum generation with inline ejectors SLP for handling plastic injection molded parts

### Our Highlights...

- Inline vacuum generator with axial connections
- Low device weight (5 g)
- Nozzles with high suction capacity at high vacuum values
- Slimline plastic housing
- Connection by means of push-in couplings

### Your Benefits...

- Direct installation in the vacuum hose
- Ideal for highly dynamic processes
- Minimum air consumption
- Suitable for installation in restricted spaces
- No need for additional connecting elements

- Schmalz – The Company
- Vacuum Suction Cups
- Special Grippers
- Gripping Systems
- Clamping Systems
- Mounting Elements
- Vacuum Generators
- Valve Technology
- Switches and Monitoring
- Filters and Connections
- Services
- Contact
- Glossary
- Index of Products

# Inline Ejectors SLP

Suction rate from 8 l/min to 16 l/min



## Designation Code Inline Ejectors SLP

<b>SLP</b>	-	<b>05</b>	-	<b>S01</b>
1		2		3

### 1 - Abbreviated designation

Code	Version
SLP	SLP

### 2 - Nozzle size

Code	Diameter in mm
05...07	ø 0.5 and 0.7

### 3 - Connection

Code	Connection
S01	Quick connect push-in coupling 1

Inline ejector SLP is delivered as a ready-to-connect product.



## Ordering Data Inline Ejectors SLP

Type	Part no.
SLP 05 S01	10.02.01.00561
SLP 07 S01	10.02.01.00562



## Technical Data Inline Ejectors SLP

Type	Nozzle diameter [mm]	Degree of evacuation [%]	Suction rate (max) [l/min]	Suction rate (max) [m³/h]	Air consumption suction [l/min]*	Air consumption suction [m³/h]**
SLP 05 S01	0.5	85	8	0.5	13	0.8
SLP 07 S01	0.7	85	16	1.0	25	1.5

\*At optimal operating pressure

\*\*At optimal operating pressure

Type	Noise level suction [dB(A)]	Noise level free [dB(A)]	Pressure optimal [bar]	Recomm. internal hose diameter compressed air [mm]*	Weight [g]	Operating temperature [°C]
SLP 05 S01	52	60	4.5	2	5	0 ... 60
SLP 07 S01	63	63	4.5	2	5	0 ... 60

\*For max. length 2 m

# Inline Ejectors SLP

Suction rate from 8 l/min to 16 l/min

- Schmalz – The Company
- Vacuum Suction Cups
- Special Grippers
- Gripping Systems
- Clamping Systems
- Mounting Elements
- Vacuum Generators**
- Valve Technology
- Switches and Monitoring
- Filters and Connections
- Services
- Contact
- Glossary
- Index of Products



## Performance Data Inline Ejectors SLP

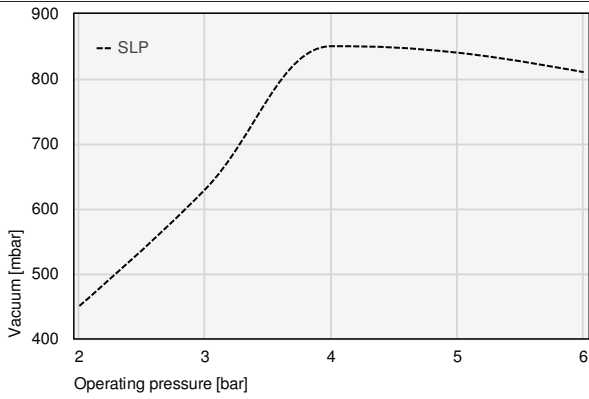

Achievable vacuum at various operating pressures

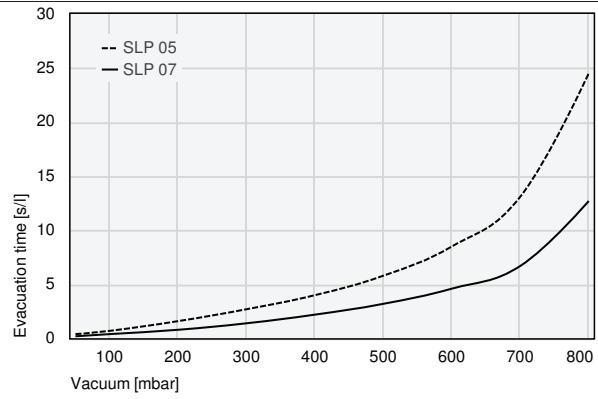

Evacuation times for various vacuum ranges [s/l]

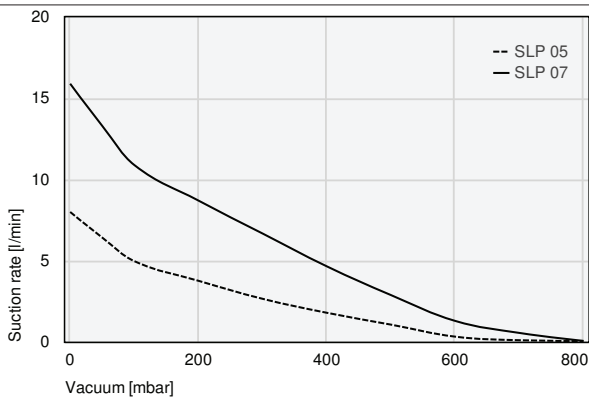

Suction capacity at various degrees of evacuation [l/min]



## Evacuation times for various vacuum ranges [s/l]

	50	100	200	300	400	500	600	700	800
SLP 05	0.40	0.70	1.60	2.70	4.00	5.80	8.50	13.10	24.50
SLP 07	0.20	0.40	0.80	1.40	2.20	3.20	4.60	6.70	12.70



## Suction capacity at various degrees of evacuation [l/min]

	0	50	100	200	300	400	500	600	700	800
SLP 05	8.00	6.42	4.97	3.76	2.65	1.79	1.06	0.32	0.10	0.05
SLP 07	15.90	13.30	10.89	8.70	6.67	4.65	2.88	1.29	0.55	0.06



# Inline Ejectors SLP

Suction rate from 8 l/min to 16 l/min



## Design Data Inline Ejectors SLP

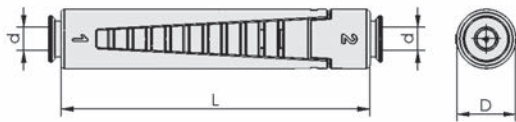

SLP

Type	d [mm]	D [mm]	L [mm]
SLP 05 S01	4	10	57
SLP 07 S01	4	10	57

- Schmalz – The Company
- Vacuum Suction Cups
- Special Grippers
- Gripping Systems
- Clamping Systems
- Mounting Elements
- Vacuum Generators**
- Valve Technology
- Switches and Monitoring
- Filters and Connections
- Services
- Contact
- Glossary
- Index of Products



# Inline Ejectors VR

Suction rate from 7 l/min to 24 l/min



## Suitability for Industry Specific Applications

### Applications

- Inline ejector for installation between suction cup and compressed air supply
- Handling of all types of workpieces with manipulators, industrial robots and feeder systems



Inline Ejectors VR

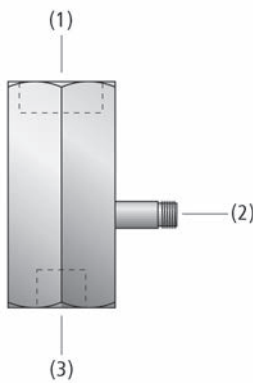

System Design Inline Ejectors VR

### Design

- Body made of anodized aluminum
- Nozzle system made of brass
- Vacuum generator with single nozzle
- Compressed air inlet (1)
- Exhaust air outlet (2)
- Vacuum inlet (3)



Decentralized vacuum generation with inline ejector VR for handling plastic parts

### Our Highlights...

- Inline ejector for installation between suction cup and compressed air supply
- Minimum size and low weight due to aluminum body

### Your Benefits...

- No costly hose installation necessary; vacuum is generated directly at the point of use
- Extremely space-saving installation; ideal for restricted spaces and highly dynamic movements

- Schmalz – The Company
- Vacuum Suction Cups
- Special Grippers
- Gripping Systems
- Clamping Systems
- Mounting Elements
- Vacuum Generators
- Valve Technology
- Switches and Monitoring
- Filters and Connections
- Services
- Contact
- Glossary
- Index of Products



# Inline Ejectors VR

Suction rate from 7 l/min to 24 l/min

## Designation Code Inline Ejectors VR



**1** – Abbreviated designation

Code	Version
VR	VR

**2** – Nozzle size

Code	Diameter in mm
05...09	ø 0.5 to 0.9

Inline ejector VR is delivered as a ready-to-connect product.

## Ordering Data Inline Ejectors VR

Type	Part no.
VR 05	10.02.01.00075
VR 07	10.02.01.00001
VR 09	10.02.01.00077

## Technical Data Inline Ejectors VR

Type	Nozzle diameter [mm]	Degree of evacuation [%]	Suction rate (max.) [l/min]	Suction rate (max.) [m³/h]	Air consumption suction [l/min]*	Air consumption suction [m³/h]**	Weight [g]	Operating temperature [°C]	Pressure optimal [bar]
VR 05	0.5	87	7	0.4	12	0.7	15	0 ... 60	5
VR 07	0.7	90	14	0.8	21	1.3	15	0 ... 60	5
VR 09	0.9	89	21	1.3	36	2.2	15	0 ... 60	5

\*At optimal operating pressure

\*\*At optimal operating pressure

## Performance Data Inline Ejectors VR

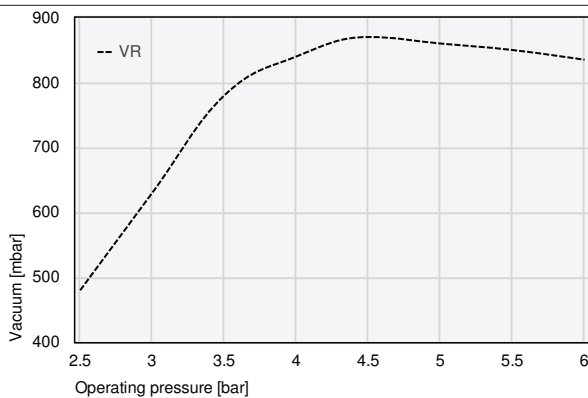

Achievable vacuum at various operating pressures

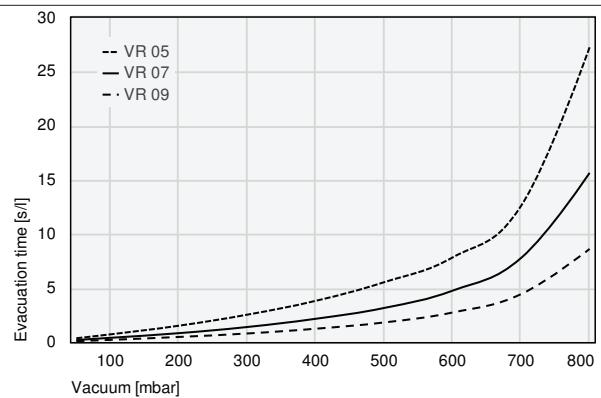

Evacuation times for various vacuum ranges [s/l]

# Inline Ejectors VR

Suction rate from 7 l/min to 24 l/min

## Performance Data Inline Ejectors VR

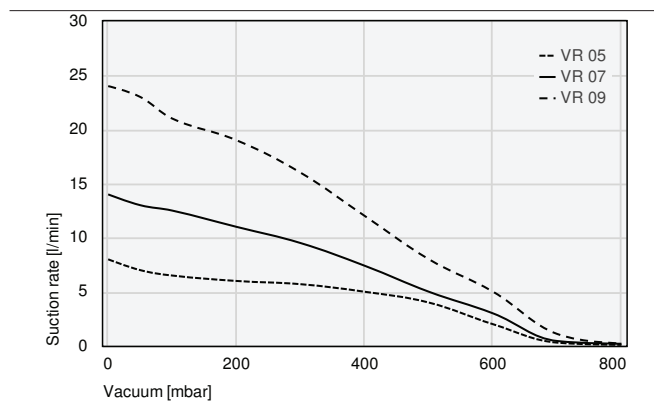

Suction capacity at various degrees of evacuation [l/min]

## Evacuation times for various vacuum ranges [s/l]

	50	100	200	300	400	500	600	700	800
VR 05	0.37	0.73	1.53	2.55	3.83	5.55	7.84	12.61	27.25
VR 07	0.21	0.41	0.84	1.41	2.17	3.17	4.77	7.79	15.65
VR 09	0.10	0.22	0.49	0.81	1.25	1.83	2.75	4.45	8.62

## Suction capacity at various degrees of evacuation [l/min]

	0	50	100	200	300	400	500	600	700	800
VR 05	8.00	7.00	6.50	6.00	5.70	5.00	4.00	2.00	0.30	0.10
VR 07	14.00	13.00	12.50	11.00	9.50	7.40	5.00	3.00	0.45	0.20
VR 09	24.00	23.00	21.00	19.00	16.00	12.00	8.00	5.00	1.10	0.24

- Schmalz – The Company
- Vacuum Suction Cups
- Special Grippers
- Gripping Systems
- Clamping Systems
- Mounting Elements
- Vacuum Generators
- Valve Technology
- Switches and Monitoring
- Filters and Connections
- Services
- Contact
- Glossary
- Index of Products

# Inline Ejectors VR

Suction rate from 7 l/min to 24 l/min



## Design Data Inline Ejectors VR

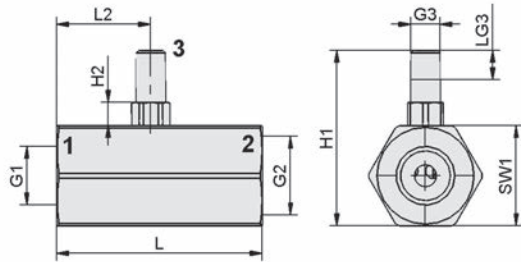

VR

Type	G1	G2	G3	H1 [mm]	H2 [mm]	L [mm]	L2 [mm]	LG3 [mm]	SW1 [mm]
VR 05	G1/4"-F	G1/8"-F	M5-M	29.8	4	35	16	5	17
VR 07	G1/4"-F	G1/8"-F	M5-M	29.8	4	35	16	5	17
VR 09	G1/4"-F	G1/8"-F	M5-M	29.8	4	35	16	5	17

Schmalz – The Company  
Vacuum Suction Cups  
Special Grippers  
Gripping Systems  
Clamping Systems  
Mounting Elements  
Vacuum Generators  
Valve Technology  
Switches and Monitoring  
Filters and Connections  
Services  
Contact  
Glossary  
Index of Products



# Ejectors with Active Blow Off SEAC

Suction rate 35 l/min

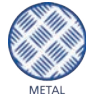

## Suitability for Industry Specific Applications

### Applications

- Ejector for many different applications with active blow off to realize shortest cycle times, e.g. in sheet-metal handling, the automotive industry, in packaging machines and robot technology



Ejectors with Active Blow Off SEAC

### Design

- Main body (1) made of plastic; smallest possible dimensions and low weight
- Silencer (2) made of anodized aluminum
- Compressed air connection for blow off (3) and for suction (4)
- Two holes (5) for connecting to tooling; vacuum connection (6)
- Two M4 mounting screws included in delivery
- Optional with vacuum switch (7) with fixed switching point at 600 mbar, 3 m connection cable and protective cover with pull-relief (SEAC VE-SH)

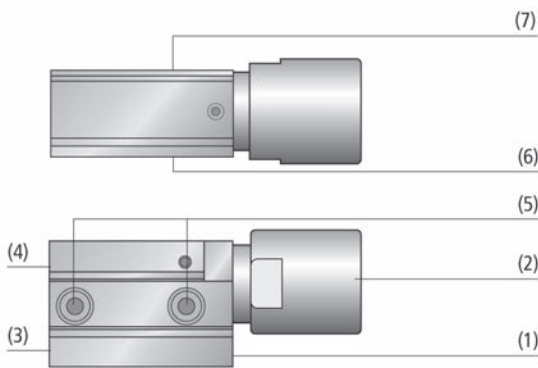

System Design Ejectors with Active Blow Off SEAC

### Our Highlights...

- Short gripping and blow off times
- Main body made of plastic
- Suitable for holder system HTS
- With silencer
- Optional available with vacuum switch

### Your Benefits...

- Very short cycle times in automated operations
- Minimum size and low weight particularly suitable for highly dynamic systems
- Direct mounting of suction cup and connector
- Reduced noise level
- Part present signal for optimization of processes



Decentral vacuum generation by ejector SEAC directly at the suction cup



- Schmalz – The Company
- Vacuum Suction Cups
- Special Grippers
- Gripping Systems
- Clamping Systems
- Mounting Elements
- Vacuum Generators
- Valve Technology
- Switches and Monitoring
- Filters and Connections
- Services
- Contact
- Glossary
- Index of Products

# Ejectors with Active Blow Off SEAC

Suction rate 35 l/min



## Designation Code Ejectors with Active Blow Off SEAC

<b>SEAC</b>	-	<b>10</b>	-	<b>VE-SH</b>
<b>1</b>		<b>2</b>		<b>3</b>

### 1 – Abbreviated designation

Code	Version
SEAC	SEAC

### 2 – Nozzle size

Code	Diameter in mm
10	ø 1

### 3 – System monitoring

Code	Type
VE-SH	Vacuum switch with cover

Ejector SEAC is delivered as a ready-to-connect product.

Accessoires: holder (ejector adapter)



## Ordering Data Ejectors with Active Blow Off SEAC

Type	Part no.
SEAC 10	10.02.02.03875
SEAC 10 VE-SH	10.02.02.03876



## Ordering Data Accessories Ejectors with Active Blow Off SEAC

Type	Part no.
Ejector adapter ADP-EJ 45.5x21x44-G1/4-IG SEAC L	10.02.02.03483
Ejector adapter ADP-EJ 45.5x21x44-G1/4-IG SEAC S	10.02.02.03484
Ejector adapter ADP-EJ 38x20x11-G1/4-IG SEAC	10.02.02.04067
Ejector adapter ADP-EJ 38x20x11-G1/8-IG SEAC	10.02.02.04068



## Technical Data Ejectors with Active Blow Off SEAC

Type	Nozzle diameter [mm]	Degree of evacuation [%]	Suction rate (max.) [l/min]	Suction rate (max.) [m³/h]	Air consumption suction [l/min]*	Max. air consumption blow off [l/min]**	Pressure range (operating pressure) [bar]	Weight [g]
SEAC 10	1.0	85	35	2.1	52	60	4.0 ... 6.0	62
SEAC 10 VE-SH	1.0	85	35	2.1	52	60	4.0 ... 6.0	157

\*At optimal operating pressure (4.5 bar)

\*\*Additional air consumption during blow off

# Ejectors with Active Blow Off SEAC

Suction rate 35 l/min

## Performance Data Ejectors with Active Blow Off SEAC

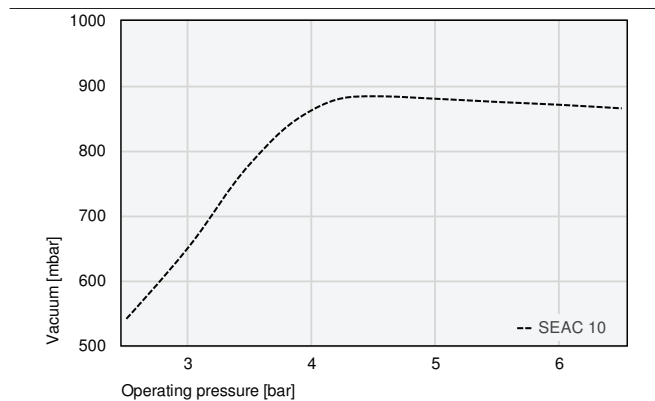

Achievable vacuum at various operating pressures

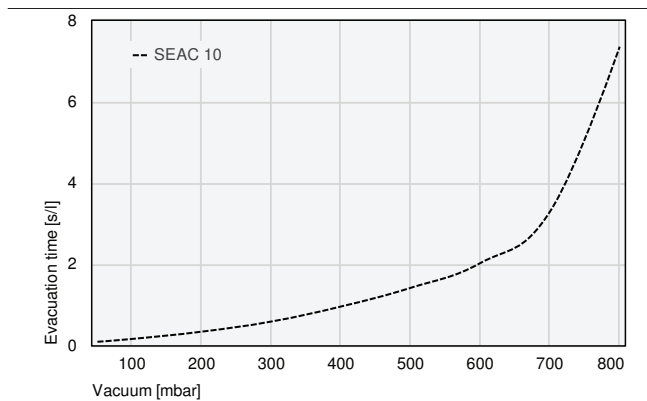

Evacuation times for various vacuum ranges [s/l]

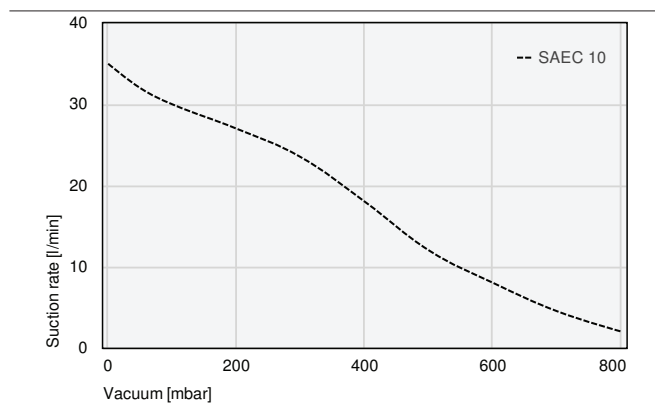

Suction capacity at various degrees of evacuation [l/min]

## Evacuation times for various vacuum ranges [s/l]

	50	100	200	300	400	500	600	700	800
SEAC 10	0.09	0.16	0.34	0.59	0.96	1.42	2.03	3.30	7.36

## Suction capacity at various degrees of evacuation [l/min]

	0	50	100	200	300	400	500	600	700	800
SAEC 10	35.0	32.0	30.0	27.0	23.5	18.0	12.0	8.2	4.5	2.0

- Schmalz – The Company
- Vacuum Suction Cups
- Special Grippers
- Gripping Systems
- Clamping Systems
- Mounting Elements
- Vacuum Generators
- Valve Technology
- Switches and Monitoring
- Filters and Connections
- Services
- Contact
- Glossary
- Index of Products

# Ejectors with Active Blow Off SEAC

Suction rate 35 l/min



## Design Data Ejectors with Active Blow Off SEAC

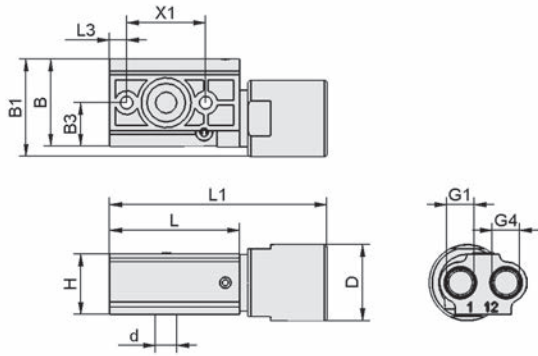

SEAC

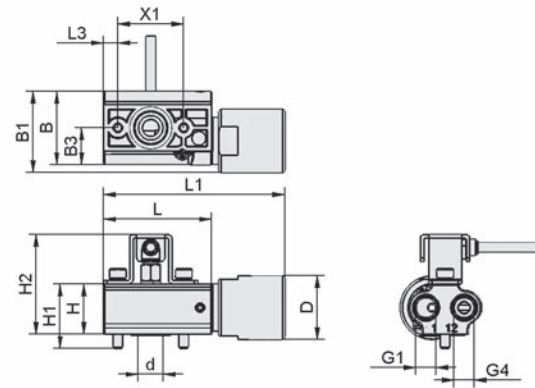

SEAC VE-SH

Type	B [mm]	B1 [mm]	B3 [mm]	d [mm]	D [mm]	G1	G4	H [mm]	H1 [mm]	H2 [mm]	L [mm]	L1 [mm]	L3 [mm]	X1 [mm]
SEAC 10	31	34.6	15.5	7.5	27	G1/8"-F	G1/8"-F	21.5	-	-	46	77	6	28
SEAC 10 VE-SH	31	34.6	15.5	7.5	27	G1/8"-F	G1/8"-F	21.5	27.5	42.5	46	77	6	28

Schmalz –  
The Company

Vacuum  
Suction Cups

Special  
Grippers

Gripping  
Systems

Clamping  
Systems

Mounting  
Elements

Vacuum  
Generators

Valve  
Technology

Switches and  
Monitoring

Filters and  
Connections

Services

Contact

Glossary

Index of  
Products

# Ejectors with Blow Off System SEAC RP

Suction rate 35 l/min

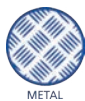

## Suitability for Industry Specific Applications

### Applications

- Ejector for vacuum generation in many different applications on tooling-systems with short cycle times, such as in sheet metal working, the automotive industry, in packaging machines and robot technology
- Decentral vacuum generation with integrated pneumatical air-saving function



Ejectors with Blow Off System SEAC RP

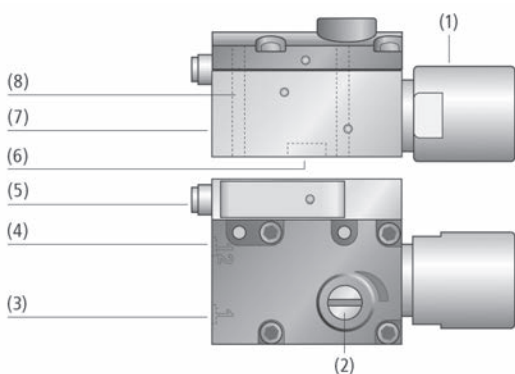

### Design

- Body made of anodized aluminum (7); integrated blow off function
- Integrated silencer (1)
- Optional vacuum switch VS-V-AH-T-PNP-S (5) with adjustable switching point
- Passage for fixation (8)
- Vacuum connection (6); compressed air inlet for suction (3) and compressed air inlet for blow off (4)
- Adjusting screw for air-saving function (2)

System Design Ejectors with Blow Off System SEAC RP



Decentralized vacuum generation with ejector SEAC RP with blow off system right on suction cup

### Our Highlights...

- Integrated pneumatical air-saving function
- Short gripping and blow off times
- Minimum size and low weight
- Suitable for modular ejector holder system
- With silencer

### Your Benefits...

- Minimum compressed air consumption, minimal requiring of fitting
- Very short cycle times in automated operations
- Particularly suitable for highly dynamic systems
- Direct mounting of suction cup and connector
- Reduced noise level



# Ejectors with Blow Off System SEAC RP

Suction rate 35 l/min



## Designation Code Ejectors with Blow Off System SEAC RP

SEAC	-	10	-	RP	-	VS-T	-	R
1		2		3		4		5

### 1 – Abbreviated designation

Code	Version
SEAC	SEAC

### 2 – Nozzle size

Code	Diameter in mm
10	ø 1

### 3 – Additional function

Code	Type
RP	Pneumatic air saving regulation

### 4 – Product addition

Code	Type
VS-T	Vacuum switch

### 5 – Mounting orientation

Code	Orientation
L	Left
R	Right

Ejector SEAC RP is delivered as a ready-to-connect product (without connection cable).

Available accessories: connection cable, holder (ejector adapter)



## Ordering Data Ejectors with Blow Off System SEAC RP

Type	Part no.
SEAC 10 RP R	10.02.02.03289
SEAC 10 RP VS-T R	10.02.02.03290
SEAC 10 RP L	10.02.02.03296
SEAC 10 RP VS-T L	10.02.02.03297



## Ordering Data Accessories Ejectors with Blow Off System SEAC RP

Type		Part no.
Connection cable, M8 4-pole, 5 m, PUR, straight	ASK B-M8-4 5000 K-4P	10.06.02.00031
Ejector adapter	ADP-EJ 45.5x21x44-G1/4-IG SEAC L	10.02.02.03483
Ejector adapter	ADP-EJ 45.5x21x44-G1/4-IG SEAC S	10.02.02.03484
Ejector adapter	ADP-EJ 38x20x11-G1/4-IG SEAC	10.02.02.04067
Ejector adapter	ADP-EJ 38x20x11-G1/8-IG SEAC	10.02.02.04068



## Technical Data Ejectors with Blow Off System SEAC RP

Type	Nozzle size [mm]	Degree of evacuation [%]	Suction rate (max.) [l/min]	Suction rate (max.) [m³/h]	Air consumption suction [l/min]*	Air consumption suction [m³/h]**	Max. air consumption blow off [l/min]	Pressure range (operating pressure) [bar]	Weight [g]
SEAC RP	1.0	85	36	2.1	65	3.9	92	4.0 ... 6.0	180

\*At optimal operating pressure

\*\*At optimal operating pressure



# Ejectors with Blow Off System SEAC RP

Suction rate 35 l/min

## Performance Data Ejectors with Blow Off System SEAC RP

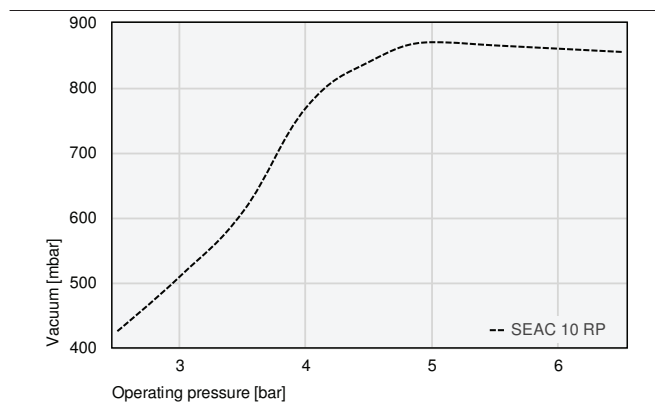

Achievable vacuum at various operating pressures

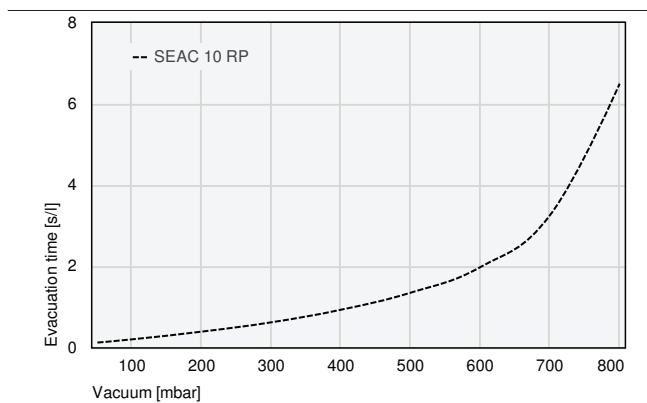

Evacuation times for various vacuum ranges [s/l]

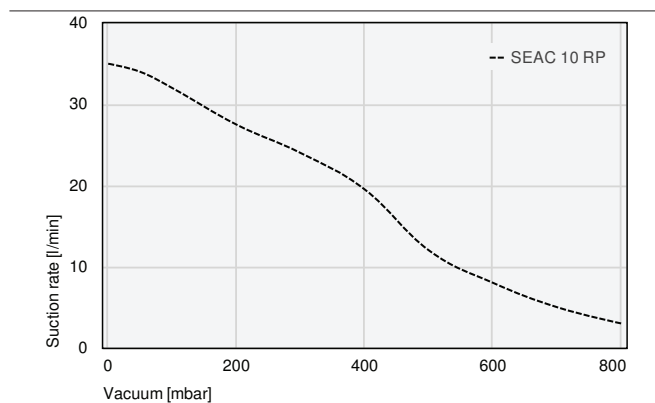

Suction capacity at various degrees of evacuation [l/min]

## Evacuation times for various vacuum ranges [s/l]

	50	100	200	300	400	500	600	700	800
SEAC 10 RP	0.12	0.20	0.39	0.62	0.93	1.35	1.98	3.26	6.50

## Suction capacity at various degrees of evacuation [l/min]

	0	50	100	200	300	400	500	600	700	800
SEAC 10 RP	35.0	34.0	32.0	27.5	24.0	19.5	12.0	8.0	5.0	3.0

- Schmalz – The Company
- Vacuum Suction Cups
- Special Grippers
- Gripping Systems
- Clamping Systems
- Mounting Elements
- Vacuum Generators
- Valve Technology
- Switches and Monitoring
- Filters and Connections
- Services
- Contact
- Glossary
- Index of Products

# Ejectors with Blow Off System SEAC RP

Suction rate 35 l/min



## Design Data Ejectors with Blow Off System SEAC RP

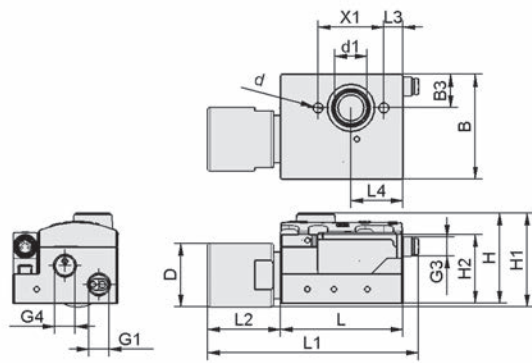

SEAC RP (VS-T) R

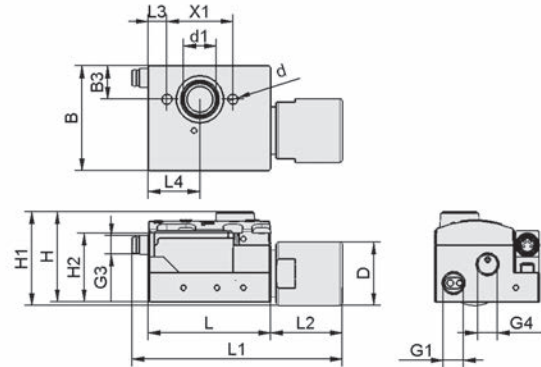

SEAC RP (VS-T) L

Type	B [mm]	B3 [mm]	d [mm]	d1 [mm]	D [mm]	G1	G3	G4	H [mm]	H1 [mm]	H2 [mm]	L [mm]	L1 [mm]	L2 [mm]	L3 [mm]	L4 [mm]	X1 [mm]
SEAC 10 RP R	44.5	14.2	4.3	13.8	27	G1/8"-F	-	G1/8"-F	38.3	39.8	29.3	52	-	29.5	8	22	28
SEAC 10 RP VS-T R	44.5	14.2	4.3	13.8	27	G1/8"-F	M8-M	G1/8"-F	38.3	39.8	29.3	52	88.1	29.5	8	22	28
SEAC 10 RP L	44.5	14.2	4.3	13.8	27	G1/8"-F	-	G1/8"-F	38.3	39.8	29.3	52	-	29.5	8	22	28
SEAC 10 RP VS-T L	44.5	14.2	4.3	13.8	27	G1/8"-F	M8-M	G1/8"-F	38.3	39.8	29.3	52	88.1	29.5	8	22	28

# Ejectors with Atmospheric Ventilation SEAC ECO

Suction rate 35 l/min

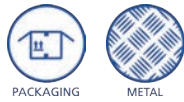

## Suitability for Industry Specific Applications

### Applications

- Ejector for decentralized vacuum generation for the use in many different applications with short cycle times
- In vacuum systems as economic solution thanks to the automatic release using atmospheric ventilation



Ejectors with Atmospheric Ventilation SEAC ECO

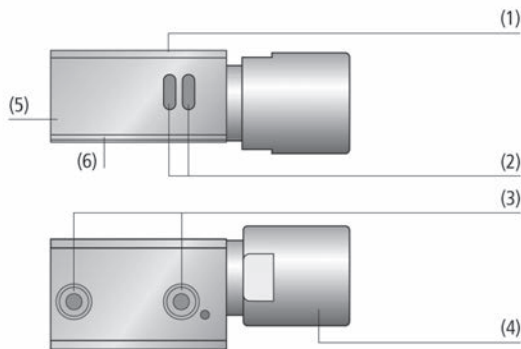

### Design

- Main body (1) made of anodized aluminum; smallest possible dimensions and low weight
- Openings for atmospheric ventilation (2)
- Two holes for connecting to holder (3)
- Silencer (4) made of anodized aluminum
- Compressed air connection (5)
- Vacuum connection (6)

System Design Ejectors with Atmospheric Ventilation SEAC ECO



Decentral vacuum generation by ejectors SEAC ECO directly at the suction cup

### Our Highlights...

- Operation with only one compressed air line
- Atmospheric ventilation
- No filter, no spare parts

### Your Benefits...

- Half installation effort and reduced costs for pneumatic installation material such as valves and hoses
- Reduced energy costs by more than 50 %, since no air is consumed during release of parts
- Maintenance free operation, reduced costs of maintenance

# Ejectors with Atmospheric Ventilation SEAC ECO

Suction rate 35 l/min



## Designation Code Ejectors with Atmospheric Ventilation SEAC ECO

<b>SEAC ECO</b>	-	<b>10</b>
<b>1</b>		<b>2</b>

### 1 – Abbreviated designation

Code	Version
SEAC ECO	SEAC ECO

### 2 – Nozzle size

Code	Diameter in mm
10	ø 1

Ejector SEAC ECO is delivered as a ready-to-connect product.

Accessoires: holder (ejector adapter)



## Ordering Data Ejectors with Atmospheric Ventilation SEAC ECO

Type	Part no.
SEAC 10 ECO	10.02.02.03702



## Ordering Data Accessories Ejectors with Atmospheric Ventilation SEAC ECO

Type		Part no.
Ejector adapter	ADP-EJ 45.5x21x44-G1/4-IG SEAC L	10.02.02.03483
Ejector adapter	ADP-EJ 45.5x21x44-G1/4-IG SEAC S	10.02.02.03484
Ejector adapter	ADP-EJ 38x20x11-G1/4-IG SEAC	10.02.02.04067
Ejector adapter	ADP-EJ 38x20x11-G1/8-IG SEAC	10.02.02.04068



## Technical Data Ejectors with Atmospheric Ventilation SEAC ECO

Type	Nozzle diameter [mm]	Degree of evacuation [%]	Suction rate (max.) [l/min]	Suction rate (max.) [m³/h]	Air consumption suction [l/min]*	Pressure range (operating pressure) [bar]	Weight [g]
SEAC 10 ECO	1	85	35	2.1	52	4.0 ... 6.0	95

\*At optimal operating pressure (4.5 bar)

# Ejectors with Atmospheric Ventilation SEAC ECO

Suction rate 35 l/min



## Performance Data Ejectors with Atmospheric Ventilation SEAC ECO

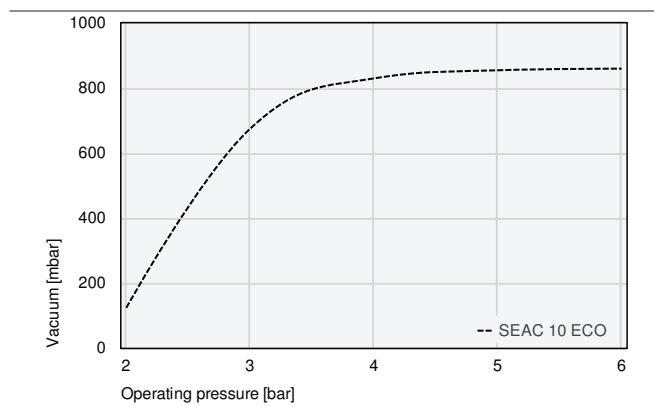

Achievable vacuum at various operating pressures

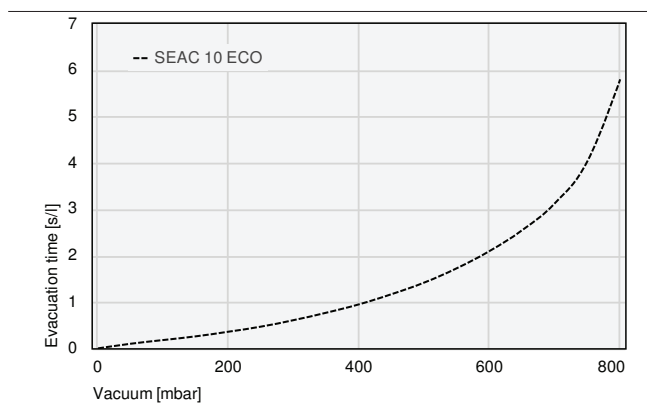

Evacuation times for various vacuum ranges [s/l]

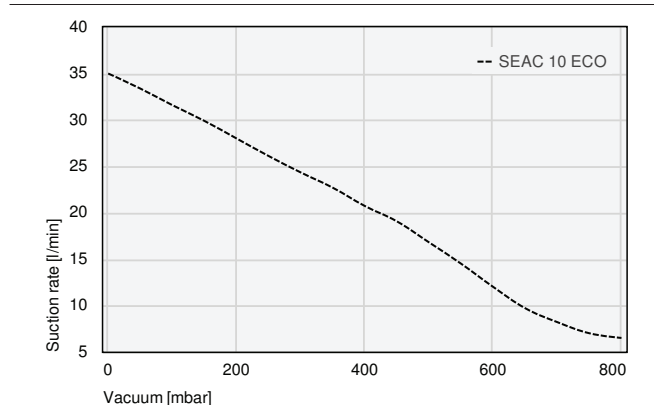

Suction capacity at various degrees of evacuation [l/min]



## Evacuation times for various vacuum ranges [s/l]

	0	50	100	200	300	400	500	600	700	800
SEAC 10 ECO	0.00	0.10	0.18	0.36	0.61	0.95	1.42	2.10	3.13	5.80



## Suction capacity at various degrees of evacuation [l/min]

	0	50	100	200	300	400	500	600	700	800
SEAC 10 ECO	35.00	33.38	31.59	28.00	24.34	20.72	16.80	12.00	8.20	6.50



- Schmalz – The Company
- Vacuum Suction Cups
- Special Grippers
- Gripping Systems
- Clamping Systems
- Mounting Elements
- Vacuum Generators**
- Valve Technology
- Switches and Monitoring
- Filters and Connections
- Services
- Contact
- Glossary
- Index of Products

# Ejectors with Atmospheric Ventilation SEAC ECO

Suction rate 35 l/min



## Design Data Ejectors with Atmospheric Ventilation SEAC ECO

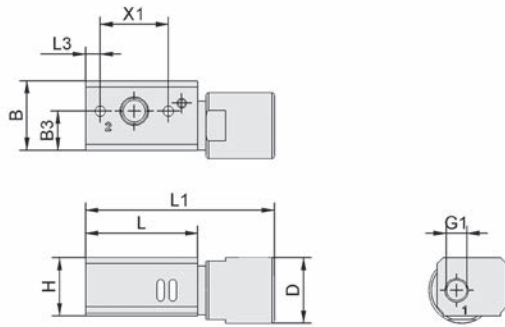

SEAC ECO

Type	B [mm]	B3 [mm]	D [mm]	G1	H [mm]	L [mm]	L1 [mm]	L3 [mm]	X1 [mm]
SEAC 10 ECO	28.5	16.1	27	G1/8"-F	24	46	77.5	6	28

# Compact Ejectors SCPSb

Suction rate from 16 l/min to 67 l/min



## Suitability for Industry Specific Applications

### Applications

- Handling of airtight and slightly porous workpieces
- Generation of vacuum in automated systems
- Use in robotic handling applications and on linear axes
- For systems that require highly dynamic gripping of workpieces and where space is limited



Compact Ejectors SCPSb

### Design

- Basic module made of high strength plastic
- Integrated pneumatic valves (1) for switching functions NO or NC
- Pneumatic connections (2) via push-in quick connect couplings
- Screw (3) to adjust blow off for lightweight pieces
- Open silencer (4)
- Can optionally be mounted using DIN rails (5)

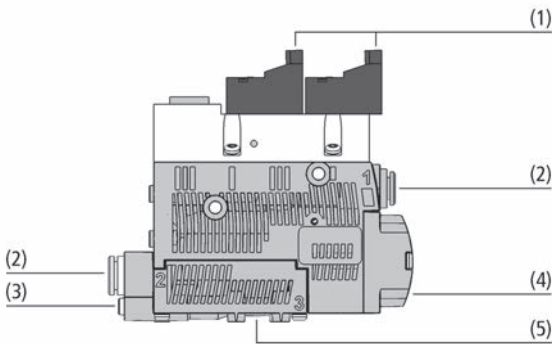

System Design Compact Ejectors SCPSb

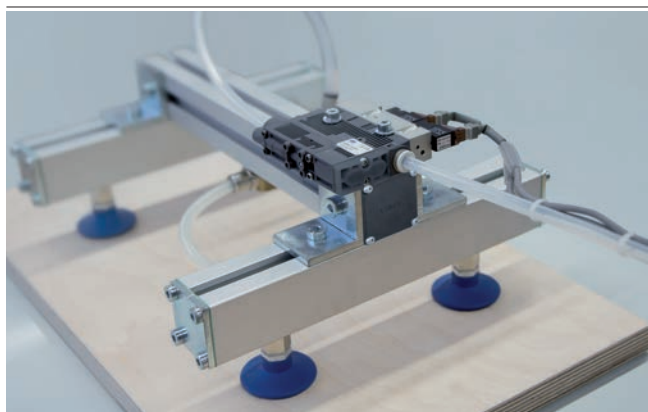

Centralized vacuum generation through compact ejector SCPSb

### Our Highlights...

- Efficient eco nozzle technology
- Compact size, made of extremely durable plastic
- Push-in connections
- Attachment point for DIN rails

### Your Benefits...

- Higher suction rate with minimal compressed air consumption
- Compact and durable unit; can be mounted directly on the handling system
- Saving in additional screw unions
- Simple installation; can also be installed in the switch cabinet

- Schmalz – The Company
- Vacuum Suction Cups
- Special Grippers
- Gripping Systems
- Clamping Systems
- Mounting Elements
- Vacuum Generators
- Valve Technology
- Switches and Monitoring
- Filters and Connections
- Services
- Contact
- Glossary
- Index of Products





# Compact Ejectors SCPSb

Suction rate from 16 l/min to 67 l/min



## Designation Code Compact Ejectors SCPSb

<b>SCPSb</b>	–	<b>2-07</b>	–	<b>S04</b>	–	<b>NO</b>
<b>1</b>		<b>2</b>		<b>3</b>		<b>4</b>

### 1 – Abbreviated designation

Code	Version
SCPSb	SCPSb

### 2 – Nozzle size

Code	Diameter in mm
07...15	ø 0.7 to 1.5 (single stage)
2-07...2-14	ø 0.7 to 1.4 (double stage)

### 3 – Connection

Code	Connection
S02	Quick connect push-in coupling 2
S04	Quick connect push-in coupling 4

### 4 – Idle position suction valve

Code	Type
NC	Normally closed
NO	Normally open

Compact ejector SCPSb is delivered as a ready-to-connect product (without connection cable).

Available accessories: connection cable, top-hat rail clamp, vacuum filter, compressed air connection plate, mounting set, exhaust air set



## Ordering Data Compact Ejectors SCPSb

Type	Part no.
SCPSb 07 S04 NC	10.02.02.04130
SCPSb 07 S04 NO	10.02.02.04129
SCPSb 10 S04 NC	10.02.02.04132
SCPSb 10 S04 NO	10.02.02.04131
SCPSb 15 S02 NC	10.02.02.04134
SCPSb 15 S02 NO	10.02.02.04133
SCPSb 2-07 S04 NC	10.02.02.04372
SCPSb 2-07 S04 NO	10.02.02.04371
SCPSb 2-09 S04 NC	10.02.02.04374
SCPSb 2-09 S04 NO	10.02.02.04373
SCPSb 2-14 S02 NC	10.02.02.04376
SCPSb 2-14 S02 NO	10.02.02.04375



## Ordering Data Accessories Compact Ejectors SCPSb

Type		Part no.
Connection cable for solenoid valves, 3 m, PUR	ASK B-MIC10 3000 K-2P	21.04.06.00086
Top-hat rail clamp	HUT-5N-KL 70x18x8	10.02.02.04149
Vacuum filter	VFI CN6/4 50	10.07.01.00241
Vacuum filter	VFI CN8/6 50	10.07.01.00245
Compressed air connection plate	GP 4 SCPS 07..15 G2	10.02.02.04338
Mounting set	SET SCPS	10.02.02.04343

Type	Accessories	Part no.
SCPSb 07	Exhaust air set	ABL-SET SCPS einstufig
SCPSb 10	Exhaust air set	ABL-SET SCPS einstufig
SCPSb 15	Exhaust air set	ABL-SET SCPS einstufig
SCPSb 2-07	Exhaust air set	ABL-SET SCPS zweistufig
SCPSb 2-09	Exhaust air set	ABL-SET SCPS zweistufig
SCPSb 2-14	Exhaust air set	ABL-SET SCPS zweistufig



# Compact Ejectors SCPSb

Suction rate from 16 l/min to 67 l/min

## Technical Data Compact Ejectors SCPSb

Type	Degree of evacuation [%]	Suction rate (max.) [m³/h]	Suction rate (max.) [l/min]	Air consumption suction [m³/h]*	Air consumption suction [l/min]**	Air consumption blow off [m³/h]	Max. air consumption blow off [l/min]
SCPSb 07	85	0.98	16.0	1.35	22.0	7.25	118
SCPSb 10	85	2.21	36.0	2.85	46.0	7.25	118
SCPSb 15	85	4.03	65.5	6.03	98.5	7.25	118
SCPSb 2-07	85	2.28	37.0	1.35	22.0	7.25	118
SCPSb 2-09	85	3.05	49.5	2.50	40.5	7.25	118
SCPSb 2-14	85	4.41	71.5	5.04	82.0	7.25	118

\*At optimal operating pressure  
 \*\*At optimal operating pressure

Type	Noise level suction [dB(A)]	Noise level free [dB(A)]	Pressure range (operating pressure) [bar]	Recomm. internal hose diameter compressed air [mm]*	Recomm. internal hose diameter vacuum [mm]**	Operating temperature [°C]
SCPSb 07	58	63	2.0 ... 6.0	4	4	0 ... 50
SCPSb 10	60	73	2.0 ... 6.0	4	4	0 ... 50
SCPSb 15	65	75	2.0 ... 6.0	4	6	0 ... 50
SCPSb 2-07	58	63	2.0 ... 6.0	4	4	0 ... 50
SCPSb 2-09	60	73	2.0 ... 6.0	4	4	0 ... 50
SCPSb 2-14	65	75	2.0 ... 6.0	4	6	0 ... 50

\*For max. length 2 m  
 \*\*For max. length 2 m

## Performance Data Compact Ejectors SCPSb

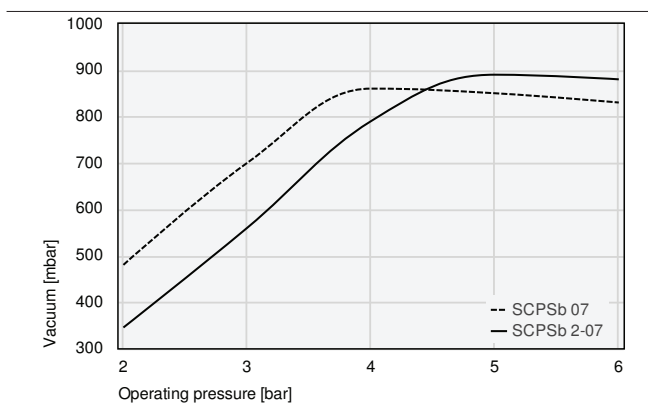

Achievable vacuum at various operating pressures

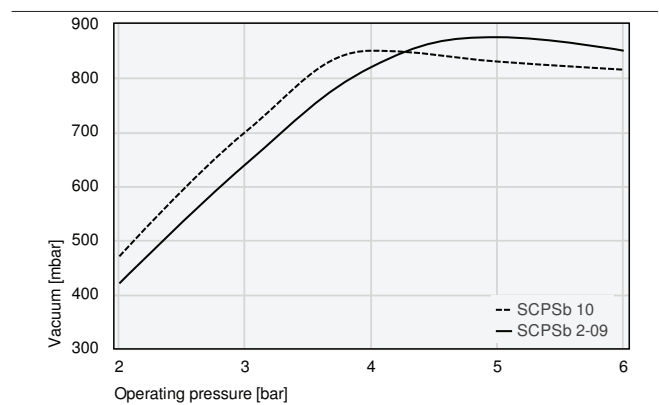

Achievable vacuum at various operating pressures

Schmalz - The Company  
 Vacuum Suction Cups  
 Special Grippers  
 Gripping Systems  
 Clamping Systems  
 Mounting Elements  
 Vacuum Generators  
 Valve Technology  
 Switches and Monitoring  
 Filters and Connections  
 Services  
 Contact  
 Glossary  
 Index of Products

Suction rate from 16 l/min to 67 l/min



## Performance Data Compact Ejectors SCPSb

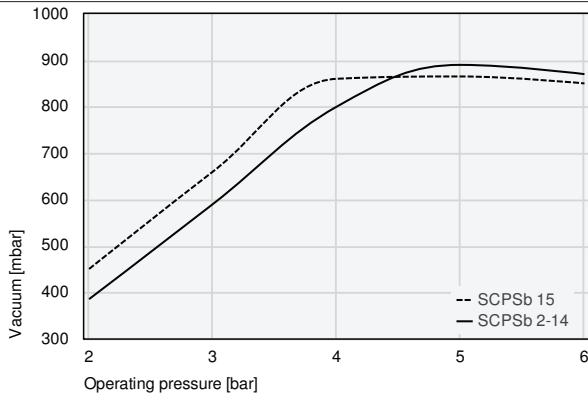

Achievable vacuum at various operating pressures

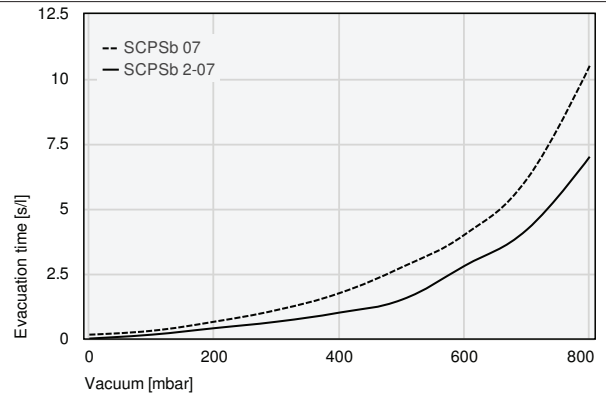

Evacuation times for various vacuum ranges [s/l]

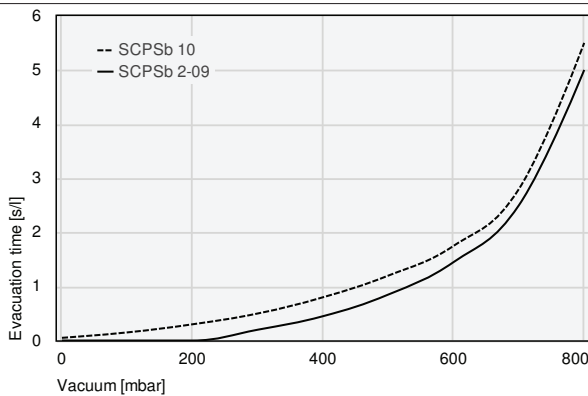

Evacuation times for various vacuum ranges [s/l]

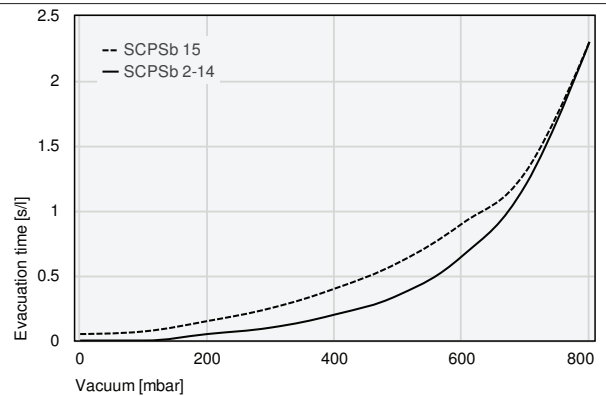

Evacuation times for various vacuum ranges [s/l]

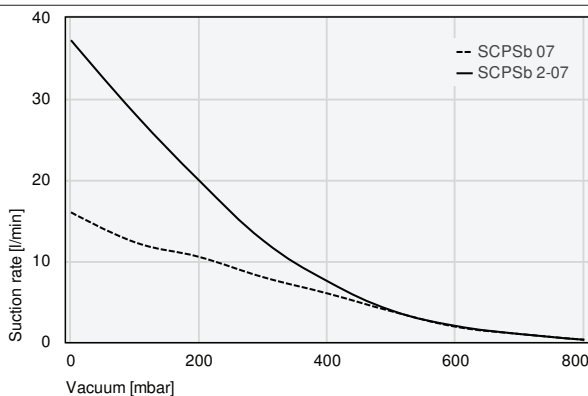

Suction capacity at various degrees of evacuation [l/min]

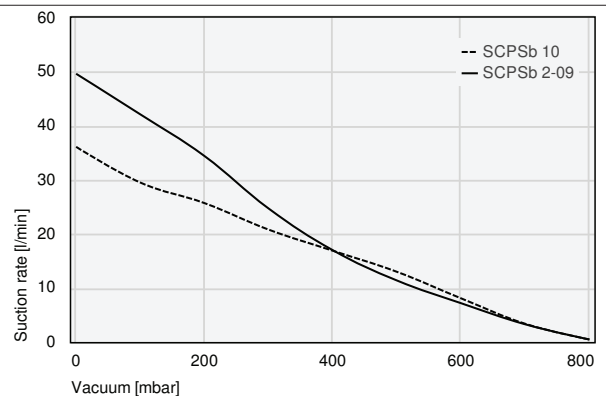

Suction capacity at various degrees of evacuation [l/min]

- Schmalz – The Company
- Vacuum Suction Cups
- Special Grippers
- Gripping Systems
- Clamping Systems
- Mounting Elements
- Vacuum Generators
- Valve Technology
- Switches and Monitoring
- Filters and Connections
- Services
- Contact
- Glossary
- Index of Products



# Compact Ejectors SCPSb

Suction rate from 16 l/min to 67 l/min

- Schmalz – The Company
- Vacuum Suction Cups
- Special Grippers
- Gripping Systems
- Clamping Systems
- Mounting Elements
- Vacuum Generators
- Valve Technology
- Switches and Monitoring
- Filters and Connections
- Services
- Contact
- Glossary
- Index of Products

## Performance Data Compact Ejectors SCPSb

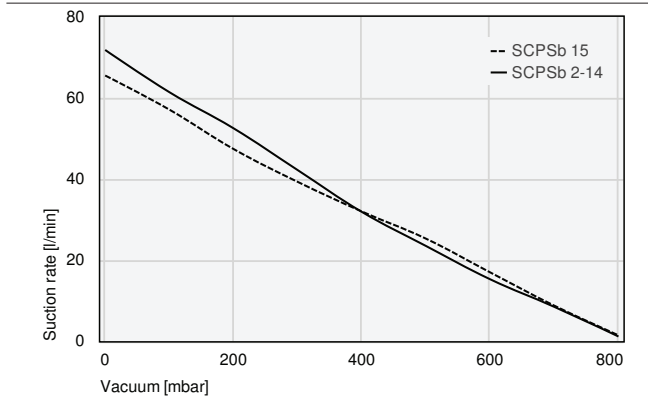

Suction capacity at various degrees of evacuation [l/min]

## Evacuation times for various vacuum ranges [s/l]

	0	100	200	300	400	500	600	700	800
SCPSb 07	0.15	0.30	0.65	1.10	1.75	2.75	4.00	6.15	10.50
SCPSb 2-07	0.00	0.15	0.40	0.65	1.00	1.50	2.80	4.20	7.00
SCPSb 10	0.05	0.15	0.30	0.50	0.80	1.20	1.75	2.80	5.50
SCPSb 2-09	0.00	0.00	0.00	0.20	0.45	0.85	1.45	2.50	5.00
SCPSb 15	0.05	0.07	0.15	0.25	0.40	0.60	0.90	1.30	2.30
SCPSb 2-14	0.00	0.00	0.05	0.10	0.20	0.35	0.65	1.20	2.30

## Suction capacity at various degrees of evacuation [l/min]

	0	100	200	300	400	500	600	700	800
SCPSb 07	16.00	12.30	10.50	8.00	6.00	3.80	1.90	1.00	0.30
SCPSb 2-07	37.20	28.10	19.90	12.50	7.50	3.90	2.00	1.00	0.30
SCPSb 10	36.1	29.5	25.7	20.8	16.9	13.0	8.10	3.40	0.50
SCPSb 2-09	49.6	42.1	34.4	24.7	17.0	11.4	7.20	3.30	0.50
SCPSb 15	65.5	57.1	47.4	39.3	32.0	25.3	17.0	8.8	1.5
SCPSb 2-14	71.8	61.4	52.5	42.2	31.9	23.5	15.3	8.5	1.2

Suction rate from 16 l/min to 67 l/min



## Design Data Compact Ejectors SCPSb

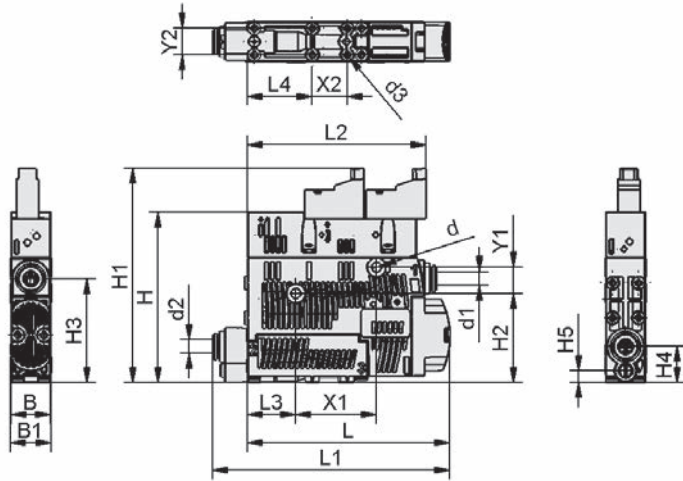

SCPSb

Type	B [mm]	B1 [mm]	d [mm]	d1 [mm]	d2 [mm]	d3 [mm]	H [mm]	H1 [mm]	H2 [mm]	H3 [mm]	H4 [mm]	H5 [mm]	L [mm]	L1 [mm]	L2 [mm]	L3 [mm]	L4 [mm]	X1 [mm]	X2 [mm]	Y1 [mm]	Y2 [mm]
SCPSb 07 S04 NC	18	18.6	4.4	6	6	2.6	77.5	97	40.8	47.5	16.5	5.5	87	102.5	81.4	22	29.5	36.9	16	12	12
SCPSb 07 S04 NO	18	18.6	4.4	6	6	2.6	77.5	97	40.8	47.5	16.5	5.5	87	102.5	81.4	22	29.5	36.9	16	12	12
SCPSb 10 S04 NC	18	18.6	4.4	6	6	2.6	77.5	97	40.8	47.5	16.5	5.5	87	102.5	81.4	22	29.5	36.9	16	12	12
SCPSb 10 S04 NO	18	18.6	4.4	6	6	2.6	77.5	97	40.8	47.5	16.5	5.5	87	102.5	81.4	22	29.5	36.9	16	12	12
SCPSb 15 S02 NC	18	18.6	4.4	6	8	2.6	77.5	97	40.8	47.5	16.5	5.5	87	102.5	81.4	22	29.5	36.9	16	12	12
SCPSb 15 S02 NO	18	18.6	4.4	6	8	2.6	77.5	97	40.8	47.5	16.5	5.5	87	102.5	81.4	22	29.5	36.9	16	12	12
SCPSb 2-07 S04 NC	18	18.6	4.4	6	6	2.6	77.5	97	40.8	47.5	16.5	5.5	94	109.5	81.4	22	29.5	36.9	16	12	12
SCPSb 2-07 S04 NO	18	18.6	4.4	6	6	2.6	77.5	97	40.8	47.5	16.5	5.5	94	109.5	81.4	22	29.5	36.9	16	12	12
SCPSb 2-09 S04 NC	18	18.6	4.4	6	6	2.6	77.5	97	40.8	47.5	16.5	5.5	94	109.5	81.4	22	29.5	36.9	16	12	12
SCPSb 2-09 S04 NO	18	18.6	4.4	6	6	2.6	77.5	97	40.8	47.5	16.5	5.5	94	109.5	81.4	22	29.5	36.9	16	12	12
SCPSb 2-14 S02 NC	18	18.6	4.4	6	8	2.6	77.5	97	40.8	47.5	16.5	5.5	94	109.5	81.4	22	29.5	36.9	16	12	12
SCPSb 2-14 S02 NO	18	18.6	4.4	6	8	2.6	77.5	97	40.8	47.5	16.5	5.5	94	109.5	81.4	22	29.5	36.9	16	12	12

Schmalz – The Company  
Vacuum Suction Cups  
Special Grippers  
Gripping Systems  
Clamping Systems  
Mounting Elements  
Vacuum Generators  
Valve Technology  
Switches and Monitoring  
Filters and Connections  
Services  
Contact  
Glossary  
Index of Products



# Compact Ejectors SCPS / SCPSi

Suction rate from 16 l/min to 67 l/min



Compact Ejectors SCPS / SCPSi

## Suitability for Industry Specific Applications

### Applications

- Compact ejector for handling of airtight and slightly porous workpieces
- Generation and monitoring of vacuum in automated systems
- Use in robotic handling applications and on linear axes
- Pick-and-place applications with extremely short cycle times
- For systems that require highly dynamic gripping of workpieces and where space is limited
- Typically for use in fully automated small parts handling applications

### Design

- Basic module made of high strength plastic and open silencer (6)
- Display screen or LED bar display (1)
- Keyboard (2) makes it easy to set the system parameters
- Electrical connection via standard M12 plug (3), with metall thread
- Integrated pneumatic valves for switching functions NO or NC
- Screw (4) to adjust blow off for lightweight pieces, pneumatic connection (5), optional mounting to DIN rails (7)

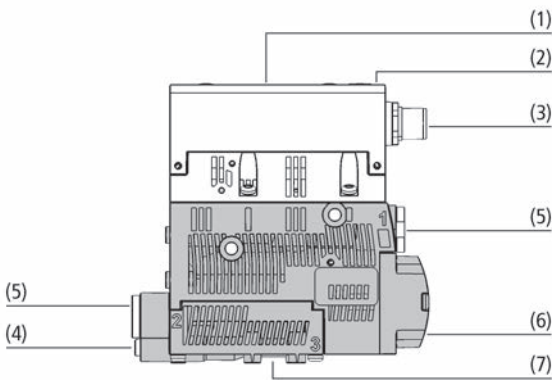

System Design Compact Ejectors SCPS / SCPSi



Centralized vacuum generation by means of compact ejector SCPSi

### Our Highlights...

- Efficient eco nozzle technology
- Integrated air-saving function
- IO-Link device for communicating with an existing fieldbus via IO-Link master
- Brightly lit display screen or LED bar display

### Your Benefits...

- Higher suction rate with minimal compressed air consumption
- Reduction of compressed air consumption by up to 80 %
- Simple and quick installation, device and process parameters can be transferred
- Highly visible display of important vacuum parameters

- Schmalz – The Company
- Vacuum Suction Cups
- Special Grippers
- Gripping Systems
- Clamping Systems
- Mounting Elements
- Vacuum Generators
- Valve Technology
- Switches and Monitoring
- Filters and Connections
- Services
- Contact
- Glossary
- Index of Products



# Compact Ejectors SCPS / SCPSi

Suction rate from 16 l/min to 67 l/min



## Designation Code Compact Ejectors SCPS / SCPSi

<b>SCPSi</b>	-	<b>2-07</b>	-	<b>G02</b>	-	<b>NO</b>	-	<b>M12-5</b>	-	<b>PNP</b>
1		2		3		4		5		6

### 1 – Abbreviated designation

Code	Version
SCPS	SCPS
SCPSi	SCPSi (IO-Link)

### 2 – Nozzle size

Code	Diameter in mm
07...15	ø 0.7 to 1.5 (single stage)
2-07...2-14	ø 0.7 to 1.4 (double stage)

### 3 – Connection

Code	Connection
G02	Connection thread 2

### 4 – Idle position suction valve

Code	Type
NC	Normally closed
NO	Normally open

### 5 – Connection electrical

Code	Connection
M12-5	M12, 5-pole

### 6 – Switching function

Code	Type
PNP	Switches to plus

Compact ejector SCPS / SCPSi is delivered as a ready-to-connect product (without connection cable).

Available accessories: connection cable, distributor, top-hat rail clamp, filter, compressed air connection plate, mounting set, exhaust air set



## Ordering Data Compact Ejectors SCPS / SCPSi

Type	Part no.
SCPS 07 G02 NC M12-5 PNP	10.02.02.04112
SCPSi 07 G02 NC M12-5	10.02.02.04121
SCPS 07 G02 NO M12-5 PNP	10.02.02.04111
SCPSi 07 G02 NO M12-5	10.02.02.04120
SCPS 10 G02 NC M12-5 PNP	10.02.02.04114
SCPSi 10 G02 NC M12-5	10.02.02.04123
SCPS 10 G02 NO M12-5 PNP	10.02.02.04113
SCPSi 10 G02 NO M12-5	10.02.02.04122
SCPS 15 G02 NC M12-5 PNP	10.02.02.04116
SCPSi 15 G02 NC M12-5	10.02.02.04125
SCPS 15 G02 NO M12-5 PNP	10.02.02.04115
SCPSi 15 G02 NO M12-5	10.02.02.04124
SCPS 2-07 G02 NC M12-5 PNP	10.02.02.04360
SCPSi 2-07 G02 NC M12-5	10.02.02.04366
SCPS 2-07 G02 NO M12-5 PNP	10.02.02.04359
SCPSi 2-07 G02 NO M12-5	10.02.02.04365
SCPS 2-09 G02 NC M12-5 PNP	10.02.02.04362
SCPSi 2-09 G02 NC M12-5	10.02.02.04368
SCPS 2-09 G02 NO M12-5 PNP	10.02.02.04361
SCPSi 2-09 G02 NO M12-5	10.02.02.04367
SCPS 2-14 G02 NC M12-5 PNP	10.02.02.04364
SCPSi 2-14 G02 NC M12-5	10.02.02.04370
SCPS 2-14 G02 NO M12-5 PNP	10.02.02.04363
SCPSi 2-14 G02 NO M12-5	10.02.02.04369



# Compact Ejectors SCPS / SCPSi

Suction rate from 16 l/min to 67 l/min



## Ordering Data Accessories Compact Ejectors SCPS / SCPSi

Type		Part no.
Connection cable, M12 5-pole, 5 m, PUR, straight	ASK B-M12-5 5000	21.04.05.00080
Connection distributor 1x M12, 5 pol, 2x M12, 4 pol	ASV SMP/SCPI 2xS-M12-4	10.02.02.03490
Top-hat rail clamp	HUT-SN-KL 70x18x8	10.02.02.04149
Vacuum filter	VFI CN6/4 50	10.07.01.00241
Vacuum filter	VFI CN8/6 50	10.07.01.00245
Compressed air connection plate	GP 4 SCPS 07..15 G2	10.02.02.04338
Mounting set	SET SCPS	10.02.02.04343

Type	Accessories		Part no.
SCPS/SCPSi	Exhaust air set	ABL-SET SCPS einstufig	10.02.02.04216
SCPS/SCPSi 2	Exhaust air set	ABL-SET SCPS zweistufig	10.02.02.04667



## Technical Data Compact Ejectors SCPS / SCPSi

Type	Degree of evacuation [%]	Suction rate (max.) [l/min]	Suction rate (max.) [m³/h]	Air consumption suction [l/min]*	Air consumption suction [m³/h]**	Air consumption blow off [m³/h]
SCPS 07	85	16.0	0.98	22.0	1.35	7.25
SCPS 10	85	36.0	2.21	46.0	2.85	7.25
SCPS 15	85	65.5	4.03	98.0	6.03	7.25
SCPS 2-07	85	37.0	2.28	22.0	1.35	7.25
SCPS 2-09	85	49.5	3.05	40.5	2.49	7.25
SCPS 2-14	85	71.5	4.40	82.0	5.04	7.25

\*At optimal operating pressure (4 bar)

\*\*At optimal operating pressure (4 bar)

Type	Noise level free [dB(A)]*	Noise level suction [dB(A)]	Pressure range (operating pressure) [bar]	Recomm. internal hose diameter compressed air [mm]**	Recomm. internal hose diameter vacuum [mm]***	Weight [kg]	Operating temperature [°C]
SCPS 07	63	58	2.0 ... 6.0	4	4	0.195	0 ... 50
SCPS 10	73	60	2.0 ... 6.0	4	4	0.195	0 ... 50
SCPS 15	73	65	2.0 ... 6.0	4	6	0.195	0 ... 50
SCPS 2-07	63	58	2.0 ... 6.0	4	4	0.195	0 ... 50
SCPS 2-09	73	60	2.0 ... 6.0	4	4	0.195	0 ... 50
SCPS 2-14	75	65	2.0 ... 6.0	4	6	0.195	0 ... 50

\*At optimal operating pressure (4 bar)

\*\*For max. length 2 m

\*\*\*For max. length 2 m



Schmalz - The Company  
Vacuum Suction Cups  
Special Grippers  
Gripping Systems  
Clamping Systems  
Mounting Elements  
Vacuum Generators  
Valve Technology  
Switches and Monitoring  
Filters and Connections  
Services  
Contact  
Glossary  
Index of Products



Suction rate from 16 l/min to 67 l/min



## Performance Data Compact Ejectors SCPS / SCPSi

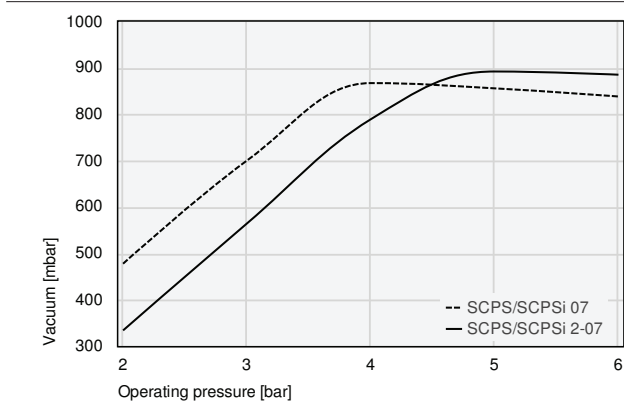

Achievable vacuum at various operating pressures

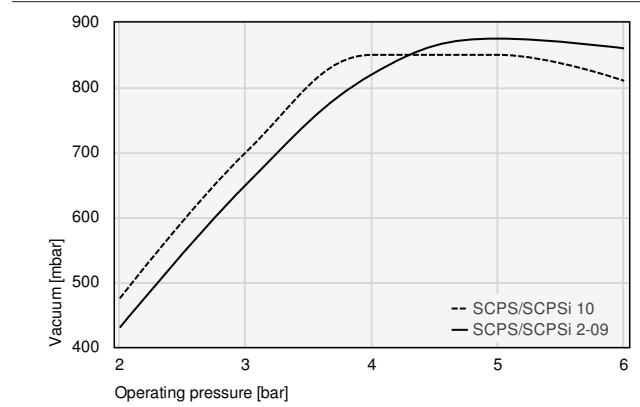

Achievable vacuum at various operating pressures

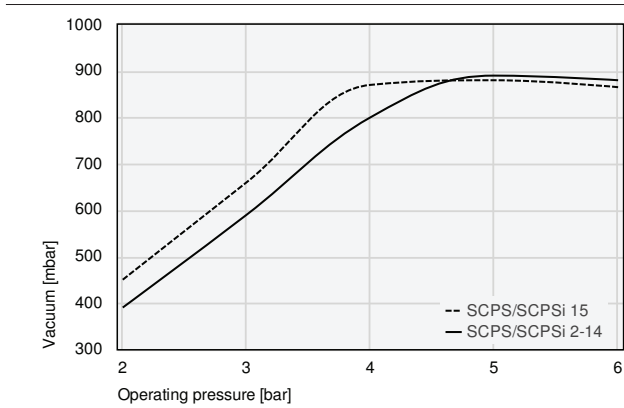

Achievable vacuum at various operating pressures

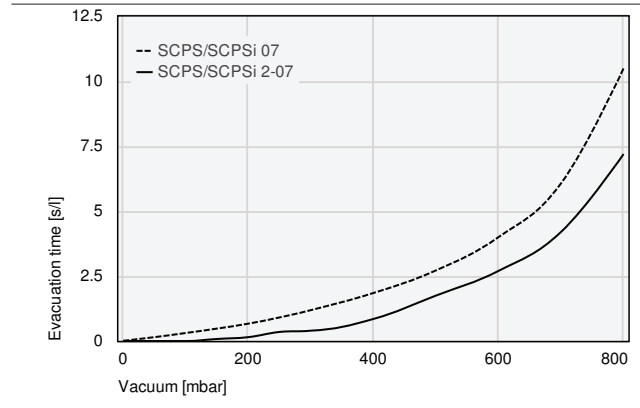

Evacuation times for various vacuum ranges [s/l]

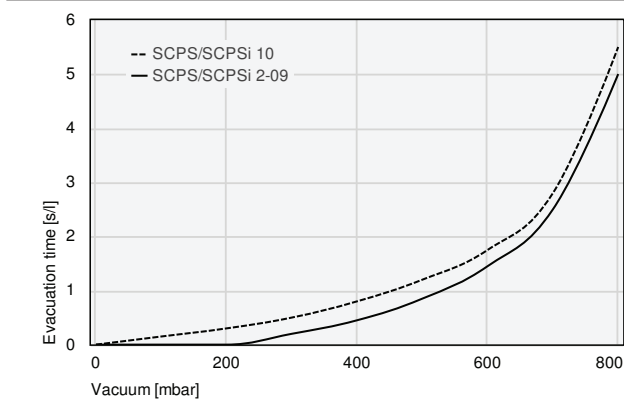

Evacuation times for various vacuum ranges [s/l]

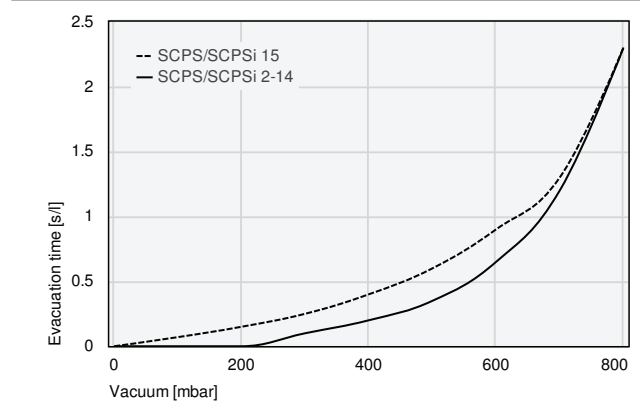

Evacuation times for various vacuum ranges [s/l]

- Schmalz – The Company
- Vacuum Suction Cups
- Special Grippers
- Gripping Systems
- Clamping Systems
- Mounting Elements
- Vacuum Generators
- Valve Technology
- Switches and Monitoring
- Filters and Connections
- Services
- Contact
- Glossary
- Index of Products



# Compact Ejectors SCPS / SCPSi

Suction rate from 16 l/min to 67 l/min

- Schmalz – The Company
- Vacuum Suction Cups
- Special Grippers
- Gripping Systems
- Clamping Systems
- Mounting Elements
- Vacuum Generators
- Valve Technology
- Switches and Monitoring
- Filters and Connections
- Services
- Contact
- Glossary
- Index of Products



## Performance Data Compact Ejectors SCPS / SCPSi

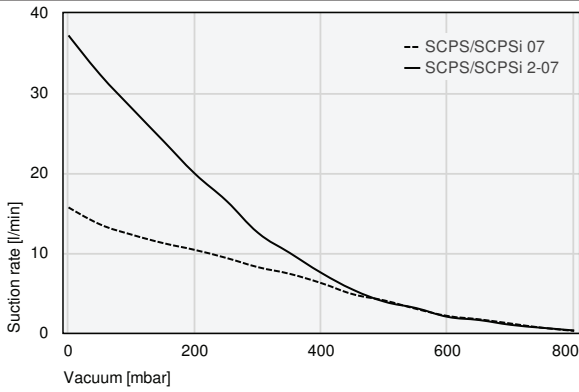

Suction capacity at various degrees of evacuation [l/min]

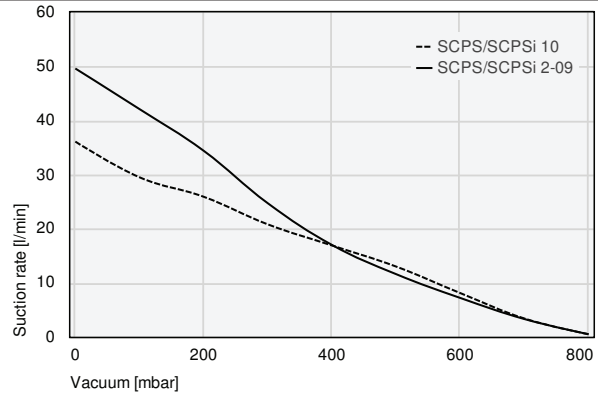

Suction capacity at various degrees of evacuation [l/min]

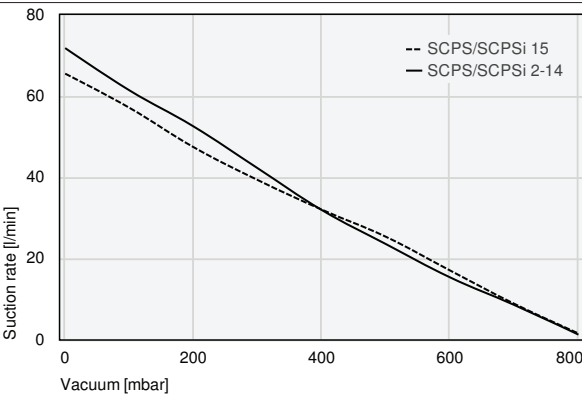

Suction capacity at various degrees of evacuation [l/min]



## Evacuation times for various vacuum ranges [s/l]

	0	50	100	200	300	400	500	600	700	800
SCPS/SCPSi 07	0.01	0.15	0.31	0.67	1.19	1.85	2.72	4.00	6.07	10.5
SCPS/SCPSi 2-07	0.00	0.00	0.00	0.15	0.40	0.85	1.75	2.70	4.20	7.20

	100	200	300	400	500	600	700	800
SCPS/SCPSi 10	0.15	0.30	0.50	0.80	1.20	1.75	2.80	5.50
SCPS/SCPSi 2-09	-	-	0.20	0.45	0.85	1.45	2.50	5.00

	100	200	300	400	500	600	700	800
SCPS/SCPSi 15	0.07	0.15	0.25	0.40	0.60	0.90	1.30	2.30
SCPS/SCPSi 2-14	-	-	0.10	0.20	0.35	0.65	1.20	2.30



# Compact Ejectors SCPS / SCPSi

Suction rate from 16 l/min to 67 l/min

## Suction capacity at various degrees of evacuation [l/min]

	0	50	100	200	300	400	500	600	700	800
SCPS/SCPSi 07	15.69	13.56	12.28	10.37	8.21	6.22	4.05	2.11	1.16	0.25
SCPS/SCPSi 2-07	37.20	32.30	28.10	19.90	12.50	7.50	3.90	2.00	1.00	0.30

	0	100	200	300	400	500	600	700	800
SCPS/SCPSi 10	36.1	29.5	25.9	20.8	16.9	13.0	8.1	3.4	0.5
SCPS/SCPSi 2-09	49.6	42.1	34.4	24.7	17.0	11.6	7.2	3.3	0.5

	0	100	200	300	400	500	600	700	800
SCPS/SCPSi 15	65.5	57.1	47.4	39.3	32.0	25.3	17.0	8.8	1.5
SCPS/SCPSi 2-14	71.8	61.4	52.5	42.2	31.9	23.5	15.3	8.5	1.2

## Design Data Compact Ejectors SCPS / SCPSi

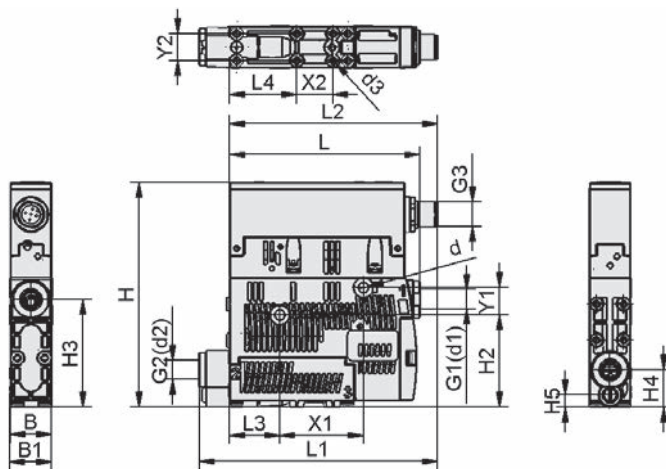

SCPS/SCPSi

Type	B [mm]	B1 [mm]	d [mm]	d3 [mm]	G1	G2	G3	H [mm]	H2 [mm]	H3 [mm]	H4 [mm]
SCPS/SCPSi	18	18.6	4.4	2.6	G1/8"-F	G1/8"-F	M12x1-M	99	40.8	47.5	16.5
SCPS/SCPSi 2	18	18.6	4.4	2.6	G1/8"-F	G1/8"-F	M12x1-M	99	40.8	47.5	16.5

Type	H5 [mm]	L [mm]	L1 [mm]	L2 [mm]	L3 [mm]	L4 [mm]	X1 [mm]	X2 [mm]	Y1 [mm]	Y2 [mm]
SCPS/SCPSi	5.5	84	105.0	91.5	22	29.5	36.9	16	12	12
SCPS/SCPSi 2	5.5	93	106.0	91.5	22	29.5	36.9	16	12	12

# Compact Ejectors X-Pump SXPi / SXMPi with IO-Link

Suction rate from 185 l/min to 220 l/min

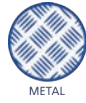

## Suitability for Industry Specific Applications

### Applications

- High performance vacuum generator for handling suction tight workpieces under extreme conditions, e.g. in vacuum systems in press lines for handling metal sheets
- In pick-and-place applications with short cycle times
- In automated systems for preparation and precise monitoring of the vacuum system



Compact Ejectors X-Pump SXPi / SXMPi with IO-Link

### Design

- User display (1) with large scale operating and display elements
- Control electronics (2) with diverse monitoring functions
- Electrical connection (3) via M12 plug
- Removable silencer (4)
- Basic body (5) made of extremely robust plastic, compact ejector SXMPi is additionally equipped with the power blow off module (6)
- Horizontal connection plate with vacuum and compressed air connection (7); optional with quick change adapter

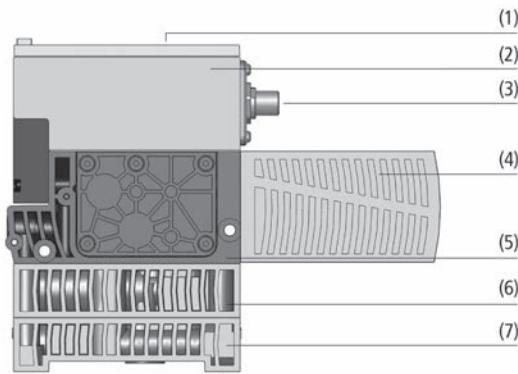

System Design Compact Ejectors X-Pump SXPi / SXMPi with IO-Link



Central vacuum generation by compact ejectors X-Pump SXPi / SXMPi

### Our Highlights...

- Communication via IO-Link technology
- Integrated air-saving function
- Condition monitoring functions with internal and external evaluation options
- Integrated voltage regulator
- Integrated pressure monitoring (optional)

### Your Benefits...

- Input and output of process specific data
- Significant reduction of energy consumption
- Process and system monitoring to avoid downtimes
- Compensation of variations in voltage
- Additional information on operating status

- Schmalz – The Company
- Vacuum Suction Cups
- Special Grippers
- Gripping Systems
- Clamping Systems
- Mounting Elements
- Vacuum Generators
- Valve Technology
- Switches and Monitoring
- Filters and Connections
- Services
- Contact
- Glossary
- Index of Products



# Compact Ejectors X-Pump SXPi / SXMPi with IO-Link

Suction rate from 185 l/min to 220 l/min



## Designation Code Compact Ejectors X-Pump SXPi / SXMPi with IO-Link



### 1 – Abbreviated designation

Code	Version
SXPi	Without power blow off
SXMPi	With power blow off

### 2 – Nozzle size

Code	Diameter in mm
25...30	ø 2.5 and 3

### 3 – Idle position suction valve

Code	Type
IMP	Bistable switched with pulse
NC	Normally closed
NO	Normally open

### 4 – Connection pneumatical

Code	Connection
H	Horizontal
Q	Quick change

### 5 – Additional function

Code	Type
PC	Pressure monitoring

### 6 – Connection electrical

Code	Connection
M12-8	M12, 8-pole
2xM12-5	2xM12, 5-pole

Compact ejector SXPi / SXMPi is delivered as a ready-to-connect product (without connection cable).

Available spare parts: connection cable, base plate, ejector tester



## Ordering Data Compact Ejectors X-Pump SXPi / SXMPi with IO-Link

Type				Nozzle size:	
				25	30
SXPi	IMP	H	M12-8	10.02.02.03792	10.02.02.03796
SXPi	IMP	Q	M12-8	10.02.02.03793	10.02.02.03797
SXPi	IMP	H	2xM12-5	10.02.02.03794	10.02.02.03798
SXPi	IMP	Q	2xM12-5	10.02.02.03795	10.02.02.03799
SXPi	NC	H	M12-8	10.02.02.03784	10.02.02.03788
SXPi	NC	Q	M12-8	10.02.02.03785	10.02.02.03789
SXPi	NC	H	2xM12-5	10.02.02.03786	10.02.02.03790
SXPi	NC	Q	2xM12-5	10.02.02.03787	10.02.02.03791
SXPi	NO	H	M12-8	10.02.02.03776	10.02.02.03780
SXPi	NO	Q	M12-8	10.02.02.03777	10.02.02.03781
SXPi	NO	H	2xM12-5	10.02.02.03778	10.02.02.03782
SXPi	NO	Q	2xM12-5	10.02.02.03779	10.02.02.03783

Type				Nozzle size:		
				25	30	
SXMPi	IMP	H	-	M12-8	10.02.02.03816	10.02.02.03820
SXMPi	IMP	H	PC	M12-8	-	10.02.02.04561
SXMPi	IMP	Q	-	M12-8	10.02.02.03817	10.02.02.03821
SXMPi	IMP	H	-	2xM12-5	10.02.02.03818	10.02.02.03822
SXMPi	IMP	H	PC	2xM12-5	10.02.02.04022	10.02.02.04097
SXMPi	IMP	Q	-	2xM12-5	10.02.02.03819	10.02.02.03823
SXMPi	IMP	Q	PC	2xM12-5	10.02.02.04563	-
SXMPi	NC	H	-	M12-8	10.02.02.03808	10.02.02.03812
SXMPi	NC	H	PC	M12-8	10.02.02.04189	-
SXMPi	NC	Q	-	M12-8	10.02.02.03809	10.02.02.03813

Schmalz – The Company  
Vacuum Suction Cups  
Special Grippers  
Gripping Systems  
Clamping Systems  
Mounting Elements  
Vacuum Generators  
Valve Technology  
Switches and Monitoring  
Filters and Connections  
Services  
Contact  
Glossary  
Index of Products

# Compact Ejectors X-Pump SXPi / SXMPi with IO-Link

Suction rate from 185 l/min to 220 l/min



## Ordering Data Compact Ejectors X-Pump SXPi / SXMPi with IO-Link

Type	Nozzle size:	
	25	30
SXMPi NC Q PC M12-8	10.02.02.04025	-
SXMPi NC H - 2xM12-5	10.02.02.03810	10.02.02.03814
SXMPi NC H PC 2xM12-5	10.02.02.04021	-
SXMPi NC Q - 2xM12-5	10.02.02.03811	10.02.02.03815
SXMPi NC Q PC 2xM12-5	10.02.02.04024	-
SXMPi NO H - M12-8	10.02.02.03800	10.02.02.03804
SXMPi NO Q - M12-8	10.02.02.03801	10.02.02.03805
SXMPi NO H - 2xM12-5	10.02.02.03802	10.02.02.03806
SXMPi NO H PC 2xM12-5	10.02.02.04023	-
SXMPi NO Q - 2xM12-5	10.02.02.03803	10.02.02.03807



## Ordering Data Accessories Compact Ejectors X-Pump SXPi / SXMPi with IO-Link

Type		Part no.
Connection cable, M12 8-pole, 5 m, PUR, straight	ASK B-M12-8 5000	21.04.05.00079
Connection cable, M12 5-pole, 5 m, PUR, straight	ASK B-M12-5 5000	21.04.05.00080
Connection cable, M12 8-pole, M12 4-pole, 1 m, PUR, straight	ASK B-M12-8 1000 S-M12-4	21.04.05.00167
Basic plate	GPQ1 122x46x43 SXPi/SXMPi	10.02.02.02473
Basic plate	GPQ2 122x87x48 SXPi/SXMPi	10.02.02.02154
Ejector tester	EJEK-TEST SMPi/SCPi	10.02.02.03588



## Technical Data Compact Ejectors X-Pump SXPi / SXMPi with IO-Link

Type*	Nozzle size [mm]	Degree of evacuation [%]	Suction rate (max.) [l/min]	Suction rate (max.) [m³/h]	Air consumption suction [l/min]**	Air consumption suction [m³/h]***	Max. air consumption blow off [l/min]
SXPi	2.5	85	185	11.1	290	17.4	200
SXPi	3.0	85	220	13.2	380	22.8	200
SXMPi	2.5	85	185	11.1	290	17.4	320
SXMPi	3.0	85	220	13.2	380	22.8	320

\*The supply voltage for vacuum switches and solenoid valves is 24 V DC

\*\*At optimal operating pressure (4.5 bar)

\*\*\*At optimal operating pressure (4.5 bar)

Type*	Noise level free [dB(A)]	Pressure range (operating pressure) [bar]	Recomm. internal hose diameter compressed air [mm]**	Recomm. internal hose diameter vacuum [mm]***	Weight [kg]	Operating temperature [°C]
SXPi	67	3.0 ... 6.0	8	9	0.77	0 ... 50
SXPi	72	3.0 ... 6.0	8	9	0.77	0 ... 50
SXMPi	67	3.0 ... 6.0	8	9	0.91	0 ... 50
SXMPi	72	3.0 ... 6.0	8	9	0.91	0 ... 50

\*The supply voltage for vacuum switches and solenoid valves is 24 V DC

\*\*For max. length 2 m

\*\*\*For max. length 2 m



# Compact Ejectors X-Pump SXPi / SXMPi with IO-Link

Suction rate from 185 l/min to 220 l/min



## Performance Data Compact Ejectors X-Pump SXPi / SXMPi with IO-Link

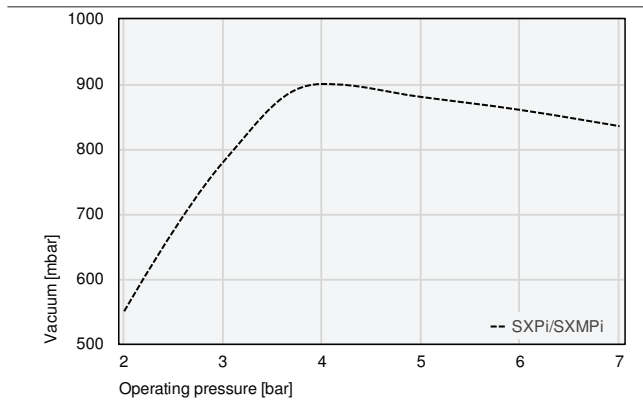

Achievable vacuum at various operating pressures

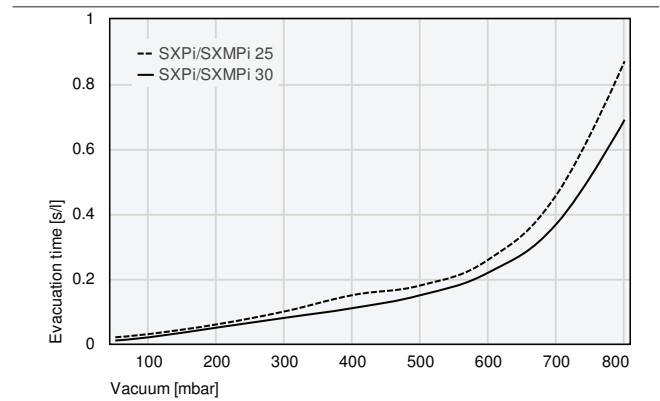

Evacuation times for various vacuum ranges [s/l]

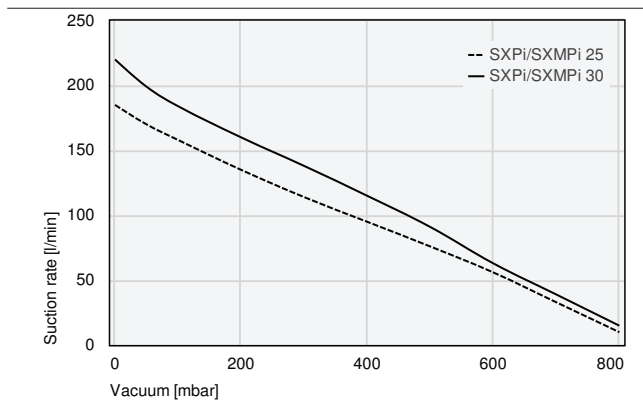

Suction capacity at various degrees of evacuation [l/min]



## Evacuation times for various vacuum ranges [s/l]

	50	100	200	300	400	500	600	700	800
SXPi/SXMPi 25	0.02	0.03	0.06	0.10	0.15	0.18	0.26	0.46	0.87
SXPi/SXMPi 30	0.01	0.02	0.05	0.08	0.11	0.15	0.22	0.37	0.69



## Suction capacity at various degrees of evacuation [l/min]

	0	50	100	200	300	400	500	600	700	800
SXPi/SXMPi 25	185	170	158	135	114	95	76	56	33	10
SXPi/SXMPi 30	220	199	184	160	138	115	91	63	39	15

Schmalz – The Company  
Vacuum Suction Cups  
Special Grippers  
Gripping Systems  
Clamping Systems  
Mounting Elements  
Vacuum Generators  
Valve Technology  
Switches and Monitoring  
Filters and Connections  
Services  
Contact  
Glossary  
Index of Products



# Compact Ejectors X-Pump SXPi / SXMPi with IO-Link

Suction rate from 185 l/min to 220 l/min



## Design Data Compact Ejectors X-Pump SXPi / SXMPi with IO-Link

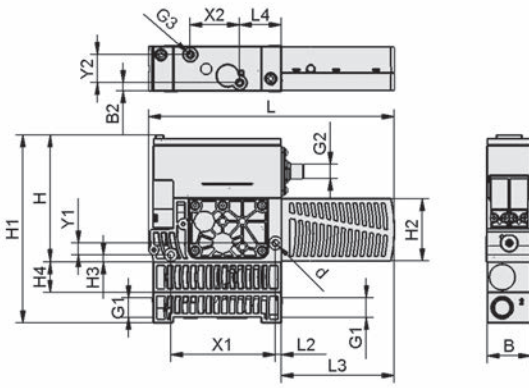

SX(M)Pi H

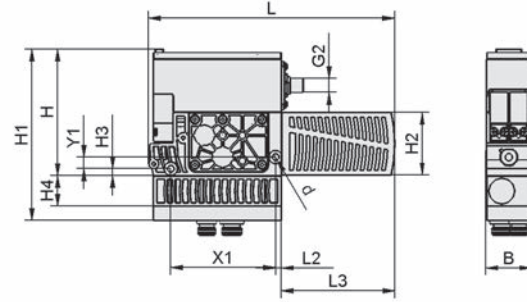

SX(M)Pi Q

Type		B	B2	d	G1	G2	G3	H	H1	H2	H3	H4	L	L2	L3	L4	X1	X2	Y1	Y2
		[mm]	[mm]	[mm]				[mm]	[mm]	[mm]	[mm]	[mm]	[mm]	[mm]	[mm]	[mm]	[mm]	[mm]	[mm]	[mm]
SXPi	H	39	6.8	5.5	G3/8"-F	M12x1-M	M5-F	108	134	54	6	-	210	5	97	35.5	89	42	10	24
SXPi	Q	39	-	5.5	-	M12x1-M	-	108	120	54	6	-	210	5	97	-	89	-	10	-
SXMPi	H	39	6.8	5.5	G3/8"-F	M12x1-M	M5-F	160	160	54	6	26	210	5	97	35.5	89	42	10	24
SXMPi	Q	39	-	5.5	-	M12x1-M	-	146	160	54	6	26	210	5	97	-	89	-	10	-



- Schmalz - The Company
- Vacuum Suction Cups
- Special Grippers
- Gripping Systems
- Clamping Systems
- Mounting Elements
- Vacuum Generators
- Valve Technology
- Switches and Monitoring
- Filters and Connections
- Services
- Contact
- Glossary
- Index of Products



# Compact Ejectors SCPi / SMPi

Suction rate from 75 l/min to 195 l/min



Compact Ejectors SCPi / SMPi

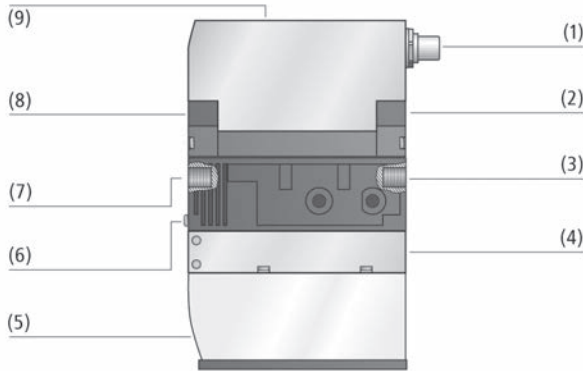

System Design Compact Ejectors SCPi / SMPi



Centralized vacuum generation by compact ejectors SMPi

## Suitability for Industry Specific Applications

### Applications

- Handling of airtight as well as porous workpieces
- Vacuum supply and vacuum monitoring in automated systems
- For use in sheet metal processing, the automotive industry, with packaging machines, and in various robotic applications
- Pick-and-place applications with very short cycle times (fast gripping and release realized by means of the power blow off function)

### Design

- Main body made of high strength plastic
- User display (9) with seven segments, operating keyboard and luminous display that indicates system status
- Electrical connection (1) via standard M12 plug, optional with potential separation of sensor and actor power supply
- Integrated pneumatic valves for NO, NC or pulse switch functions (2) and (8)
- Power blow off piston for type SMPi (4) provides extremely high blow off capacity for reduced cycle times
- Adjusting screw to adjust the blow off capacity (6); pneumatic connections (G3/8" and G1/4") with protective filters (3) and (7); integrated silencer (5)

### Our Highlights...

- IO-Link function with remote parameterisation
- Clearly structured user display with setting buttons
- Integrated air-saving function
- Compact disk design
- Weight optimized housing

### Your Benefits...

- Connection to bus systems and fast data synchronisation
- Easy to enter and read vacuum parameters
- Reduced energy costs
- Minimal space requirements
- Minimal stress during high accelerations

Schmalz – The Company

Vacuum Suction Cups

Special Grippers

Gripping Systems

Clamping Systems

Mounting Elements

Vacuum Generators

Valve Technology

Switches and Monitoring

Filters and Connections

Services

Contact

Glossary

Index of Products



# Compact Ejectors SCPi / SMPi

Suction rate from 75 l/min to 195 l/min

## Designation Code Compact Ejectors SCPi / SMPi



### 1 – Abbreviated designation

Code	Version
SCPi	Without power blow off
SMPi	With power blow off

### 2 – Nozzle size

Code	Diameter in mm
15...25	ø 1.5 to 2.5

### 3 – Idle position suction valve

Code	Type
IMP	Bistable switched with pulse
NC	Normally closed
NO	Normally open

### 4 – System monitoring

Code	Type
RD	Air saving function with digital vacuum switch
VD	Digital vacuum switch

### 5 – Connection electrical

Code	Connection
M12-5	M12, 5-pole

Compact ejector SCPi / SMPi is delivered as a ready-to-connect product (without connection cable).

Available accessories: connection cable, connection distributor, compressed air connection plate, ejector blanking plate, quick change connection (Adapter Quick Change), ejector tester

## Ordering Data Compact Ejectors SCPi / SMPi

Type				Nozzle size:		
				15	20	25
SCPi	IMP	RD	M12-5	10.02.02.03347	10.02.02.03359	10.02.02.03371
SCPi	IMP	VD	M12-5	10.02.02.03344	10.02.02.03356	10.02.02.03368
SCPi	NO	VD	M12-5	10.02.02.03342	10.02.02.03354	10.02.02.03366
SCPi	NO	RD	M12-5	10.02.02.03345	10.02.02.03357	10.02.02.03369
SCPi	NC	RD	M12-5	10.02.02.03346	10.02.02.03358	10.02.02.03370
SCPi	NC	VD	M12-5	10.02.02.03343	10.02.02.03355	10.02.02.03367

Type				Nozzle size:		
				15	20	25
SMPi	IMP	RD	M12-5	10.02.02.03341	10.02.02.03353	10.02.02.03365
SMPi	IMP	VD	M12-5	10.02.02.03338	10.02.02.03350	10.02.02.03362
SMPi	NO	RD	M12-5	10.02.02.03339	10.02.02.03351	10.02.02.03363
SMPi	NO	VD	M12-5	10.02.02.03336	10.02.02.03348	10.02.02.03360
SMPi	NC	RD	M12-5	10.02.02.03340	10.02.02.03352	10.02.02.03364
SMPi	NC	VD	M12-5	10.02.02.03337	10.02.02.03349	10.02.02.03361

# Compact Ejectors SCPI / SMPi

Suction rate from 75 l/min to 195 l/min



## Ordering Data Accessories Compact Ejectors SCPI / SMPi

Type		Part no.
Connection cable, M12 5-pole, 5 m, PUR, straight	ASK B-M12-5 5000	21.04.05.00080
Connection distributor 1x M12, 5 pol, 3x M12, 4 pol	ASV SMPi/SCPI 3xS-M12-4	10.02.02.03372
Connection distributor 1x M12, 5 pol, 2x M12, 4 pol	ASV SMPi/SCPI 2xS-M12-4	10.02.02.03490
Compressed air connection plate	GP 2 SMP 15..30/SCP 20..30	10.02.02.00917
Compressed air connection plate	GP 3 SMP 15..25/SCP 20..25	10.02.02.00918
Compressed air connection plate	GP 4 SMP 15..20/SCP 20	10.02.02.00919
Compressed air connection plate	GP 5 SMP 15	10.02.02.00920
Compressed air connection plate	GP 6 SMP 15	10.02.02.00921
Ejector blanking plate	EJEK-PL SMP(i)15..30/SCP(i)20..30	10.02.02.00728
Quick-Change-Adapter	ADP-Q 90.5x22x29.7 SMPi/SCPi	10.02.02.03463
Ejector tester	EJEK-TEST SMPi/SCPi	10.02.02.03588



## Technical Data Compact Ejectors SCPI / SMPi

Type*	Nozzle diameter [mm]	Degree of evacuation [%]	Suction rate (max.) [l/min]	Suction rate (max.) [m³/h]	Air consumption suction [l/min]**	Air consumption suction [m³/h]***	Max. air consumption blow off [l/min]
SCPi 15	1.5	85	75	4.5	115	7.2	200
SCPi 20	2.0	85	140	8.4	180	11.7	200
SCPi 25	2.5	85	195	11.7	290	17.4	200
SMPi 15	1.5	85	75	4.5	115	7.2	200
SMPi 20	2.0	85	135	8.1	180	10.8	200
SMPi 25	2.5	85	185	11.1	290	17.4	200

\*The supply voltage for vacuum switches and solenoid valves is 24V DC

\*\*At optimal operating pressure (4,5 bar)

\*\*\*At optimal operating pressure (4,5 bar)

Type*	Noise level free [dB(A)]	Noise level suction [dB(A)]	Pressure range (operating pressure) [bar]	Recomm. internal hose diameter compressed air [mm]**	Recomm. internal hose diameter vacuum [mm]***	Weight [kg]	Operating temperature [°C]
SCPi 15	75	70	4.0 ... 7.0	6	6	0.6	0 ... 50
SCPi 20	75	65	4.0 ... 7.0	6	8	0.6	0 ... 50
SCPi 25	78	75	4.0 ... 7.0	8	9	0.6	0 ... 50
SMPi 15	75	74	4.0 ... 7.0	6	6	0.6	0 ... 50
SMPi 20	75	70	4.0 ... 7.0	6	8	0.6	0 ... 50
SMPi 25	78	77	4.0 ... 7.0	8	9	0.6	0 ... 50

\*The supply voltage for vacuum switches and solenoid valves is 24 V DC

\*\*For max. length 2 m

\*\*\*For max. length 2 m



# Compact Ejectors SCPi / SMPi

Suction rate from 75 l/min to 195 l/min

- Schmalz – The Company
- Vacuum Suction Cups
- Special Grippers
- Gripping Systems
- Clamping Systems
- Mounting Elements
- Vacuum Generators
- Valve Technology
- Switches and Monitoring
- Filters and Connections
- Services
- Contact
- Glossary
- Index of Products

## Performance Data Compact Ejectors SCPi / SMPi

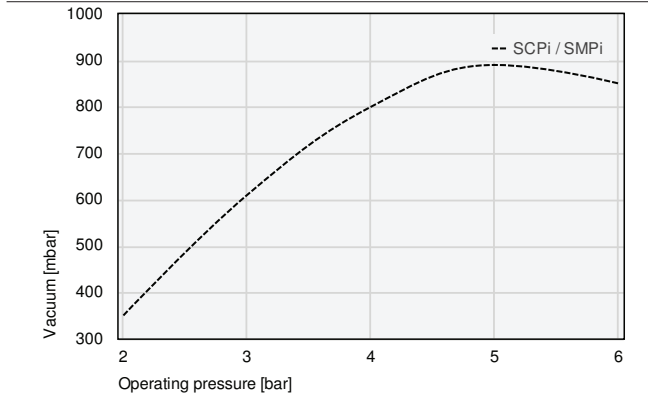

Achievable vacuum at various operating pressures

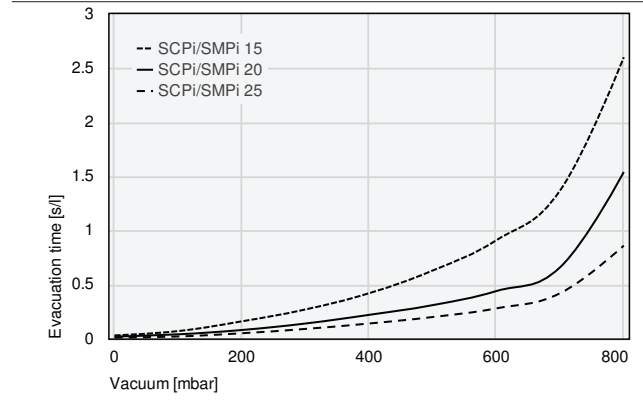

Evacuation times for various vacuum ranges [s/l]

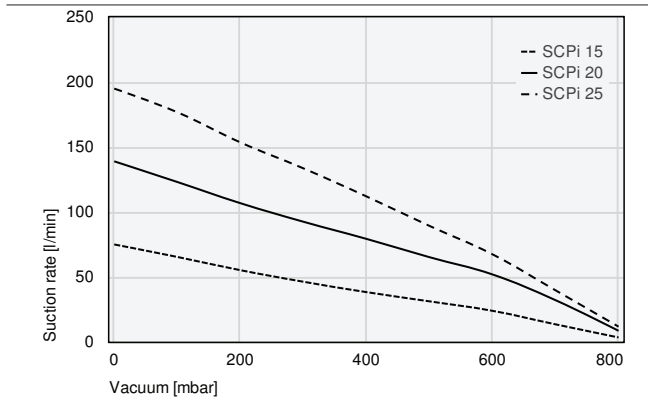

Suction capacity at various degrees of evacuation [l/min]

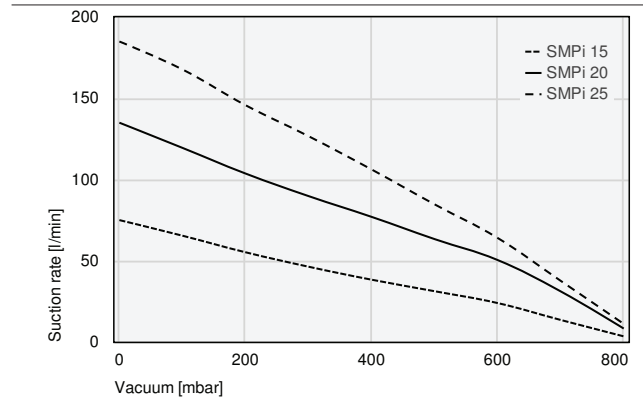

Suction capacity at various degrees of evacuation [l/min]

## Evacuation times for various vacuum ranges [s/l]

	100	200	300	400	500	600	700	800
SCPi/SMPi 15	0.07	0.16	0.27	0.42	0.63	0.91	1.37	2.60
SCPi/SMPi 20	0.04	0.08	0.14	0.22	0.31	0.44	0.66	1.54
SCPi/SMPi 25	0.02	0.05	0.09	0.14	0.20	0.28	0.42	0.86

# Compact Ejectors SCPi / SMPi

Suction rate from 75 l/min to 195 l/min



## Suction capacity at various degrees of evacuation [l/min]

	0	100	200	300	400	500	600	700	800
SCPi 15	75.0	65.4	55.2	46.3	38.3	31.2	23.9	13.5	3.4
SCPi 20	139.0	123.1	106.8	92.5	79.3	65.2	51.9	32.1	8.5
SCPi 25	195.0	176.8	153.6	133.6	112	89.3	67.4	39.7	11.7

	0	100	200	300	400	500	600	700	800
SMPi 15	75.0	65.4	55.2	46.3	38.3	31.2	23.9	13.5	3.4
SMPi 20	135.0	119.5	103.7	89.8	77.0	63.3	50.4	31.1	8.2
SMPi 25	185.0	167.8	145.8	126.7	106.2	84.7	64.0	37.6	11.1



## Design Data Compact Ejectors SCPi / SMPi

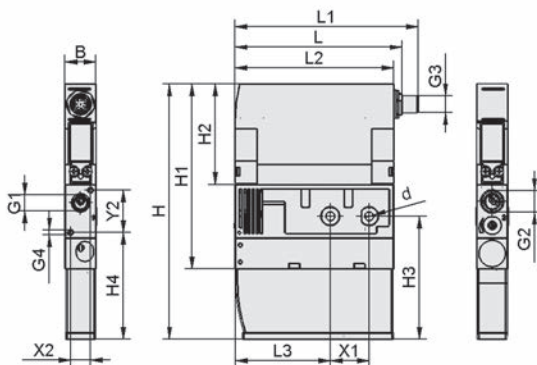

SCPi / SMPi

Type	B	d	G1	G2	G3	G4	H	H1	H2	H3	H4	L	L1	L2	L3	X1	X2	Y2
	[mm]	[mm]					[mm]	[mm]	[mm]	[mm]	[mm]	[mm]	[mm]	[mm]	[mm]	[mm]	[mm]	[mm]
SCPi 20	22	6.6	G1/4"-F	G3/8"-F	M12x1-M	M4-F	181.5	131.5	71.5	87.5	76	118.5	129.7	112.5	67.5	27.5	14	30
SCPi 25	22	6.6	G1/4"-F	G3/8"-F	M12x1-M	M4-F	181.5	131.5	71.5	87.5	76	118.5	129.7	112.5	67.5	27.5	14	30
SCPi 15	22	6.6	G1/4"-F	G3/8"-F	M12x1-M	M4-F	181.5	131.5	71.5	87.5	76	118.5	129.7	112.5	67.5	27.5	14	30
SMPi 15	22	6.6	G1/4"-F	G3/8"-F	M12x1-M	M4-F	181.5	131.5	71.5	87.5	76	118.5	129.7	112.5	67.5	27.5	14	30
SMPi 20	22	6.6	G1/4"-F	G3/8"-F	M12x1-M	M4-F	181.5	131.5	71.5	87.5	76	118.5	129.7	112.5	67.5	27.5	14	30
SMPi 25	22	6.6	G1/4"-F	G3/8"-F	M12x1-M	M4-F	181.5	131.5	71.5	87.5	76	118.5	129.7	112.5	67.5	27.5	14	30

# Compact Ejectors SCPM

Suction rate from 6 l/min to 23 l/min



## Suitability for Industry Specific Applications

### Applications

- Compact ejector for use in applications with very dynamic movements and restricted spaces
- Usage for handling with industrial robots, linear axes and in pick-and-place systems



Compact Ejectors SCPM

### Design

- Blow off valve (1) in idle position, normally closed (NC)
- Suction valve (2) in idle position, can be normally open (NO) or closed (NC)
- Compressed air connection (3)
- Basic body (4) made from anodized aluminum; integrated silencer (5) and filter (8)
- Vacuum connection (7), can be connected to a collective connection plate (battery mounting)
- Optionally with integrated vacuum switch (6)

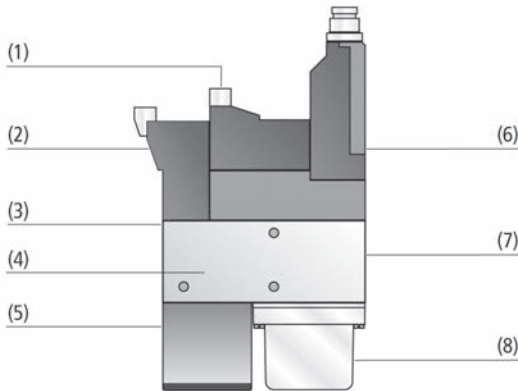

System Design Compact Ejectors SCPM

### Our Highlights...

- Minimum size and very low weight
- Versatile modular system
- Integrated valves and vacuum monitoring
- Wide range of models with different performance figures

### Your Benefits...

- Optimum vacuum generation, suitable for very dynamic movements
- Flexible adaptation to customer requirements
- Complete solution for very simple installation
- Optimum air consumption thanks to various models with differing suction capacities



Central vacuum generation by compact ejectors SCPM

- Schmalz – The Company
- Vacuum Suction Cups
- Special Grippers
- Gripping Systems
- Clamping Systems
- Mounting Elements
- Vacuum Generators
- Valve Technology
- Switches and Monitoring
- Filters and Connections
- Services
- Contact
- Glossary
- Index of Products



# Compact Ejectors SCPM

Suction rate from 6 l/min to 23 l/min

## Designation Code Compact Ejectors SCPM

<b>SCPM</b>	-	<b>07</b>	-	<b>NO</b>	-	<b>A</b>	-	<b>VS-T</b>
1		2		3		4		5

### 1 – Abbreviated designation

Code	Version
SCPM	SCPM

### 2 – Nozzle size

Code	Diameter in mm
05...10	ø 0.5 to 1

### 3 – Idle position suction valve

Code	Type
NC	Normally closed
NO	Normally open

### 4 – Blow off valve

Code	Type
A	Blow off valve

### 5 – System monitoring

Code	Type
VS-T	Electronic vacuum switch

Compact ejector SCPM is delivered as a ready-to-connect product (without connection cable).

Available spare parts: silencer, filter element (filter insert)

Available accessories: connection cable

## Ordering Data Compact Ejectors SCPM

Type	Part no.
SCPM 05 NC A	10.02.02.01071
SCPM 05 NO A	10.02.02.01072
SCPM 05 NC A VS-T	10.02.02.02498
SCPM 05 NO A VS-T	10.02.02.02499
SCPM 07 NC A	10.02.02.01067
SCPM 07 NO A	10.02.02.01068
SCPM 07 NC A VS-T	10.02.02.02500
SCPM 07 NO A VS-T	10.02.02.02501
SCPM 10 NC A	10.02.02.01063
SCPM 10 NO A	10.02.02.01064
SCPM 10 NC A VS-T	10.02.02.02502
SCPM 10 NO A VS-T	10.02.02.02503

## Ordering Data Spare Parts Compact Ejectors SCPM

Type	Part no.
Silencer (cube shaped)	SD 24x9.7x20 SCPM 10.02.02.01029
Filter insert (cube shaped)	FILT-EINS 21.7 14.5 1.6 1 SCPM 10.02.02.01037

## Ordering Data Accessories Compact Ejectors SCPM

Type	Part no.
Connection cable, M8 4-pole, 5 m, PUR, straight	ASK B-M8-4 5000 K-4P 10.06.02.00031
Connection cable, M8 4-pole, 5 m, PUR, 90°	ASK WB-M8-4 5000 K-4P 10.06.02.00032
Connection cable for solenoid valves, 3 m, PUR	ASK B-MIC10 3000 K-2P 21.04.06.00086

# Compact Ejectors SCPM

Suction rate from 6 l/min to 23 l/min

Schmalz – The Company  
Vacuum Suction Cups  
Special Grippers  
Gripping Systems  
Clamping Systems  
Mounting Elements  
Vacuum Generators  
Valve Technology  
Switches and Monitoring  
Filters and Connections  
Services  
Contact  
Glossary  
Index of Products



## Technical Data Compact Ejectors SCPM

Type*	Nozzle diameter [mm]	Degree of evacuation [%]	Suction rate (max.) [l/min]	Suction rate (max.) [m³/h]	Air consumption suction [l/min]**	Air consumption suction [m³/h]***	Max. air consumption blow off [l/min]
SCPM 05	0.5	85	6	0.4	13	0.8	26
SCPM 07	0.7	85	12	0.7	21	1.3	26
SCPM 10	1.0	85	23	1.4	46	2.8	26

\*The supply voltage for vacuum switches and solenoid valves is 24 V DC

\*\*At optimal operating pressure (4,5 bar)

\*\*\*At optimal operating pressure (4,5 bar)

Type*	Noise level suction [dB(A)]	Noise level free [dB(A)]	Pressure optimal [bar]	Recomm. internal hose diameter compressed air [mm]**	Recomm. internal hose diameter vacuum [mm]***	Weight [g]	Operating temperature [°C]
SCPM 05	62	62	4.5	2	2	90	0 ... 45
SCPM 07	67	70	4.5	2	2	90	0 ... 45
SCPM 10	73	76	4.5	2	4	90	0 ... 45

\*The supply voltage for vacuum switches and solenoid valves is 24 V DC

\*\*For max. length 2 m

\*\*\*For max. length 2 m



## Performance Data Compact Ejectors SCPM

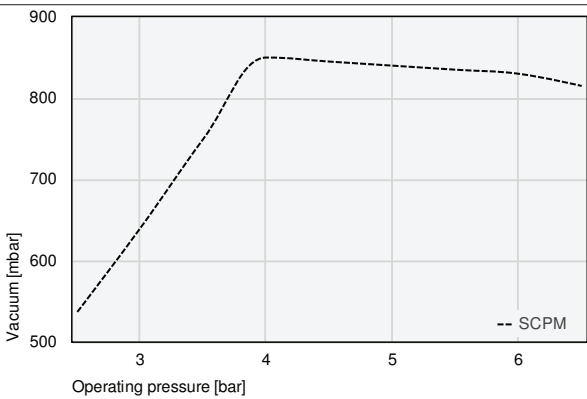

Achievable vacuum at various operating pressures

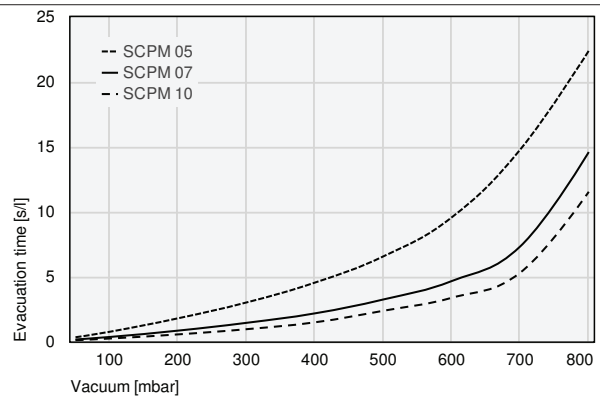

Evacuation times for various vacuum ranges [s/l]

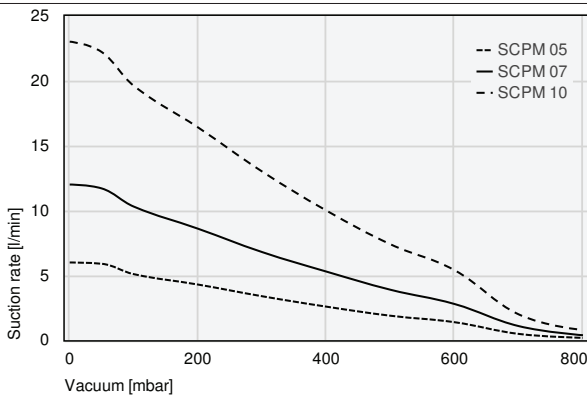

Suction capacity at various degrees of evacuation [l/min]





Suction rate from 6 l/min to 23 l/min

## Evacuation times for various vacuum ranges [s/l]

	50	100	200	300	400	500	600	700	800
SCPM 05	0.34	0.76	1.80	3.02	4.55	6.57	9.58	14.80	22.40
SCPM 07	0.17	0.36	0.85	1.45	2.18	3.25	4.67	7.34	14.60
SCPM 10	0.11	0.24	0.56	0.96	1.49	2.38	3.38	5.32	11.54

## Suction capacity at various degrees of evacuation [l/min]

	0	50	100	200	300	400	500	600	700	800
SCPM 05	6.00	5.90	5.10	4.30	3.40	2.60	1.90	1.40	0.50	0.20
SCPM 07	12.00	11.70	10.30	8.60	6.80	5.30	3.90	2.80	1.10	0.40
SCPM 10	23.00	22.20	19.60	16.40	13.00	10.00	7.40	5.40	2.00	0.80

## Design Data Compact Ejectors SCPM

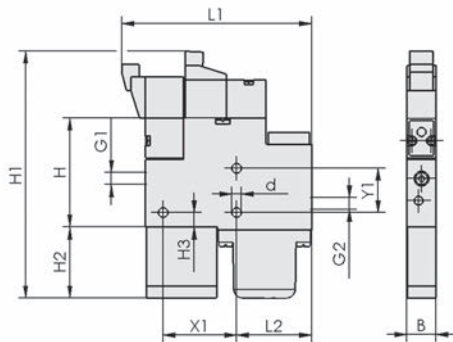

SCPM NC/NO A

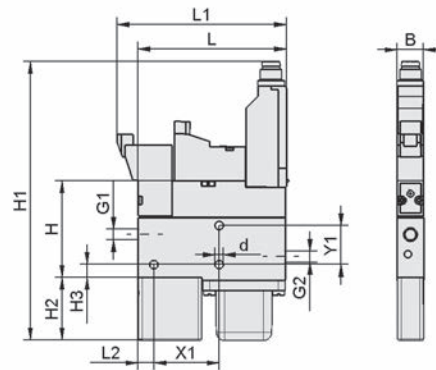

SCPM NC/NO A VS-T

Type		B [mm]	d [mm]	G1	G2	H [mm]	H1 [mm]	H2 [mm]	H3 [mm]	L [mm]	L1 [mm]	L2 [mm]	X1 [mm]	Y1 [mm]
SCPM 05	-	10.2	3.2	M5-F	M5-F	37.5	84.0	24	5	-	64.5	25.5	25	15
SCPM 07	-	10.2	3.2	M5-F	M5-F	37.5	84.0	24	5	-	64.5	25.5	25	15
SCPM 10	-	10.2	3.2	M5-F	M5-F	37.5	84.0	24	5	-	64.5	25.5	25	15
SCPM 05	VS-T	10.2	3.2	M5-F	M5-F	37.2	106.8	24	5	56.5	64.5	6.0	25	15
SCPM 07	VS-T	10.2	3.2	M5-F	M5-F	37.2	106.8	24	5	56.5	64.5	6.0	25	15
SCPM 10	VS-T	10.2	3.2	M5-F	M5-F	37.2	106.8	24	5	56.5	64.5	6.0	25	15

# Compact Ejectors SEM-C

Suction rate from 338 l/min to 673 l/min



## Suitability for Industry Specific Applications

### Applications

- Compact ejector with integrated valve technology and system monitoring for handling of cardboard, packing materials, insulating materials and other porous items



Compact Ejectors SEM-C

### Design

- Aluminum nozzle system
- Gaskets and valve flaps made of NBR
- Silencer can be mounted axially (1) or on the side (2)
- Functional mounting plate with suction valve (5) (NO or NC) and blow off valve NC (6)
- Optional vacuum switch (7)
- Vacuum connection (3), compressed air connection (4)

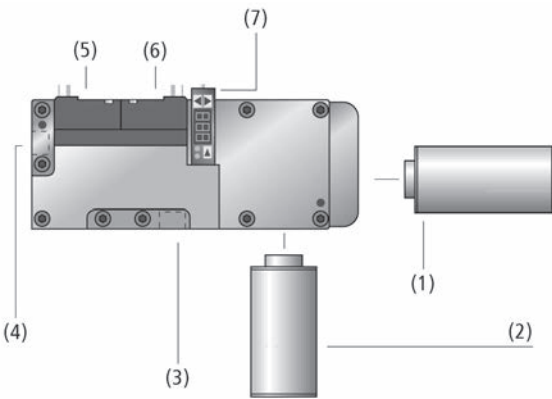

System Design Compact Ejectors SEM-C

### Our Highlights...

- Ejector family with a very high suction capacity
- Multi-stage ejector nozzle with high efficiency
- Integrated control valves and vacuum switch
- Optional automatic air-saving function

### Your Benefits...

- Fast and safe handling of all porous materials
- Fast evacuation in the lower vacuum range, cost reductions and shorter cycle times
- Compact unit for space saving installation
- Lower energy consumption when handling airtight parts



Centralized vacuum generation by compact ejectors SEM-C for handling particle boards

- Schmalz – The Company
- Vacuum Suction Cups
- Special Grippers
- Gripping Systems
- Clamping Systems
- Mounting Elements
- Vacuum Generators
- Valve Technology
- Switches and Monitoring
- Filters and Connections
- Services
- Contact
- Glossary
- Index of Products

# Compact Ejectors SEM-C

Suction rate from 338 l/min to 673 l/min



## Designation Code Compact Ejectors SEM-C

<b>SEM-C</b>	-	<b>25</b>	-	<b>SDA</b>	-	<b>NO</b>	-	<b>AS</b>	-	<b>VD</b>
<b>1</b>		<b>2</b>		<b>3</b>		<b>4</b>		<b>5</b>		<b>6</b>

### 1 – Abbreviated designation

Code	Version
SEM-C	SEM-C

### 2 – Size

Code	Type
25...100	25 to 100

### 3 – Variant

Code	Type
SDA	Silencer

### 4 – Idle position suction valve

Code	Type
NC	Normally closed
NO	Normally open

### 5 – Blow off and safety non-return valve

Code	Blow off and safety non-return valve
AS	Blow off and safety non-return valve

### 6 – System monitoring

Code	Type
VD	Digital vacuum switch

Compact ejector SEM-C is delivered as a ready-to-connect product (without connection cable).

Available spare parts: silencer

Available accessories: connection cable, distributor



## Ordering Data Compact Ejectors SEM-C

Type	Part no.
SEM-C 25 SDA NC AS	10.02.02.03203
SEM-C 25 SDA NO AS	10.02.02.03204
SEM-C 25 SDA NC AS VD	10.02.02.03205
SEM-C 25 SDA NO AS VD	10.02.02.03206
SEM-C 50 SDA NC AS	10.02.02.03207
SEM-C 50 SDA NO AS	10.02.02.02966
SEM-C 50 SDA NC AS VD	10.02.02.03208
SEM-C 50 SDA NO AS VD	10.02.02.03057
SEM-C 100 SDA NC AS	10.02.02.03215
SEM-C 100 SDA NO AS	10.02.02.03209
SEM-C 100 SDA NC AS VD	10.02.02.03210
SEM-C 100 SDA NO AS VD	10.02.02.03211

# Compact Ejectors SEM-C

Suction rate from 338 l/min to 673 l/min



## Ordering Data Spare Parts Compact Ejectors SEM-C

Type*	Spare Parts		Part no.
SEM-C 25 SDA NC AS	Silencer (round)	SD G1/2-AG 40x80 SEM	10.02.01.00309
SEM-C 25 SDA NO AS	Silencer (round)	SD G1/2-AG 40x80 SEM	10.02.01.00309
SEM-C 25 SDA NC AS VD	Silencer (round)	SD G1/2-AG 40x80 SEM	10.02.01.00309
SEM-C 25 SDA NO AS VD	Silencer (round)	SD G1/2-AG 40x80 SEM	10.02.01.00309
SEM-C 50 SDA NC AS	Silencer (round)	SD G3/4-AG 50x120 SEM	10.02.01.00312
SEM-C 50 SDA NO AS	Silencer (round)	SD G3/4-AG 50x120 SEM	10.02.01.00312
SEM-C 50 SDA NC AS VD	Silencer (round)	SD G3/4-AG 50x120 SEM	10.02.01.00312
SEM-C 50 SDA NO AS VD	Silencer (round)	SD G3/4-AG 50x120 SEM	10.02.01.00312
SEM-C 100 SDA NC AS	Silencer (round)	SD G3/4-AG 50x120 SEM	10.02.01.00312
SEM-C 100 SDA NO AS	Silencer (round)	SD G3/4-AG 50x120 SEM	10.02.01.00312
SEM-C 100 SDA NC AS VD	Silencer (round)	SD G3/4-AG 50x120 SEM	10.02.01.00312
SEM-C 100 SDA NO AS VD	Silencer (round)	SD G3/4-AG 50x120 SEM	10.02.01.00312

\*The silencers can be mounted axially or on the side, as desired



## Ordering Data Accessories Compact Ejectors SEM-C

Type	Connection cable for solenoid valves (5 m, PVC)	Connection cable, M8 4-pole, 5 m, PUR, straight	Connection cable, M8 4-pole, 5 m, PUR, 90°	Distributor for air- saving function
SEM-C 25 SDA NC AS	21.04.06.00084	-	-	-
SEM-C 25 SDA NO AS	21.04.06.00084	-	-	-
SEM-C 25 SDA NC AS VD	21.04.06.00084	10.06.02.00031	10.06.02.00032	10.02.02.01287
SEM-C 25 SDA NO AS VD	21.04.06.00084	10.06.02.00031	10.06.02.00032	10.02.02.01291
SEM-C 50 SDA NC AS	21.04.06.00084	-	-	-
SEM-C 50 SDA NO AS	21.04.06.00084	-	-	-
SEM-C 50 SDA NC AS VD	21.04.06.00084	10.06.02.00031	10.06.02.00032	10.02.02.01287
SEM-C 50 SDA NO AS VD	21.04.06.00084	10.06.02.00031	10.06.02.00032	10.02.02.01291
SEM-C 100 SDA NC AS	21.04.06.00084	-	-	-
SEM-C 100 SDA NO AS	21.04.06.00084	-	-	-
SEM-C 100 SDA NC AS VD	21.04.06.00084	10.06.02.00031	10.06.02.00032	10.02.02.01287
SEM-C 100 SDA NO AS VD	21.04.06.00084	10.06.02.00031	10.06.02.00032	10.02.02.01291



# Compact Ejectors SEM-C

Suction rate from 338 l/min to 673 l/min



## Technical Data Compact Ejectors SEM-C

Type	Degree of evacuation [%]	Suction rate (max.) [l/min]	Suction rate (max.) [m <sup>3</sup> /h]	Air consumption suction [l/min]*	Air consumption suction [m <sup>3</sup> /h]**	Noise level free [dB(A)]
SEM-C 25 SDA NC AS	87	338	20.2	100	6.0	80
SEM-C 25 SDA NO AS	87	338	20.2	100	6.0	80
SEM-C 25 SDA NC AS VD	87	338	20.2	100	6.0	80
SEM-C 25 SDA NO AS VD	87	338	20.2	100	6.0	80
SEM-C 50 SDA NC AS	86	554	33.2	190	11.4	84
SEM-C 50 SDA NO AS	86	554	33.2	190	11.4	84
SEM-C 50 SDA NC AS VD	86	554	33.2	190	11.4	84
SEM-C 50 SDA NO AS VD	86	554	33.2	190	11.4	84
SEM-C 100 SDA NC AS	81	673	40.3	246	14.8	83
SEM-C 100 SDA NO AS	81	673	40.3	246	14.8	83
SEM-C 100 SDA NC AS VD	81	673	40.3	246	14.8	83
SEM-C 100 SDA NO AS VD	81	673	40.3	246	14.8	83

\*At optimal operating pressure

\*\*At optimal operating pressure

Type	Pressure optimal [bar]	Noise level suction [dB(A)]	Recomm. internal hose diameter compressed air [mm]*	Recomm. internal hose diameter vacuum [mm]**	Weight [kg]	Operating temperature [°C]
SEM-C 25 SDA NC AS	5	70	4	20	1.6	0 ... 50
SEM-C 25 SDA NO AS	5	70	4	20	1.6	0 ... 50
SEM-C 25 SDA NC AS VD	5	70	4	20	1.7	0 ... 50
SEM-C 25 SDA NO AS VD	5	70	4	20	1.7	0 ... 50
SEM-C 50 SDA NC AS	5	60	6	25	1.9	0 ... 50
SEM-C 50 SDA NO AS	5	60	6	25	1.9	0 ... 50
SEM-C 50 SDA NC AS VD	5	60	6	25	2.0	0 ... 50
SEM-C 50 SDA NO AS VD	5	60	6	25	2.0	0 ... 50
SEM-C 100 SDA NC AS	5	63	6	32	2.2	0 ... 50
SEM-C 100 SDA NO AS	5	63	6	32	2.2	0 ... 50
SEM-C 100 SDA NC AS VD	5	63	6	32	2.2	0 ... 50
SEM-C 100 SDA NO AS VD	5	63	6	32	2.2	0 ... 50

\*For max. length 2 m

\*\*For max. length 2 m

# Compact Ejectors SEM-C

Suction rate from 338 l/min to 673 l/min

- Schmalz – The Company
- Vacuum Suction Cups
- Special Grippers
- Gripping Systems
- Clamping Systems
- Mounting Elements
- Vacuum Generators**
- Valve Technology
- Switches and Monitoring
- Filters and Connections
- Services
- Contact
- Glossary
- Index of Products

## Performance Data Compact Ejectors SEM-C

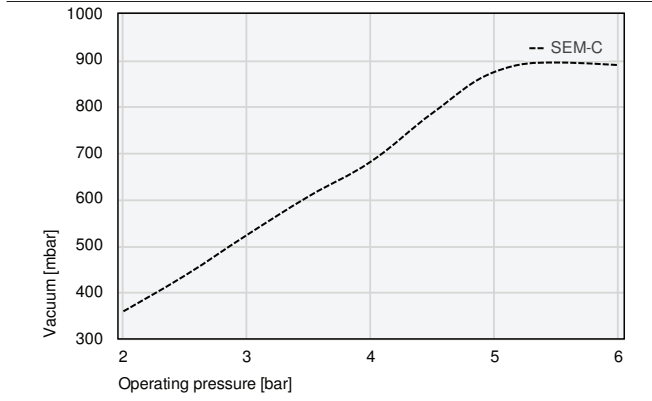

Achievable vacuum at various operating pressures

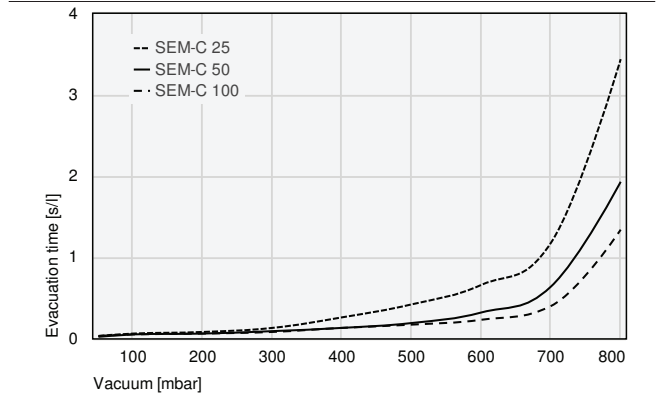

Evacuation times for various vacuum ranges [s/l]

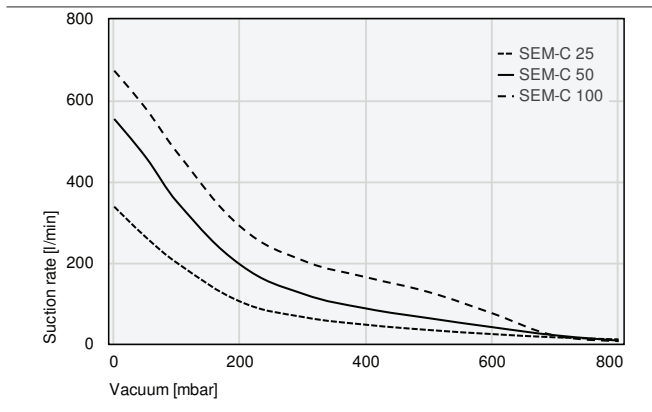

Suction capacity at various degrees of evacuation [l/min]

## Evacuation times for various vacuum ranges [s/l]

	50	100	200	300	400	500	600	700	800
SEM-C 25	0.03	0.06	0.08	0.13	0.26	0.42	0.66	1.18	3.44
SEM-C 50	0.02	0.05	0.06	0.09	0.13	0.19	0.32	0.64	1.93
SEM-C 100	0.03	0.05	0.06	0.08	0.13	0.17	0.23	0.40	1.34

## Suction capacity at various degrees of evacuation [l/min]

	0	50	100	200	300	400	500	600	700	800
SEM-C 25	338	263	199	104	66	47	34	24	16	11
SEM-C 50	554	460	349	195	123	87	63	41	21	8
SEM-C 100	673	580	471	289	205	164	127	75	20	7

Suction rate from 338 l/min to 673 l/min



## Design Data Compact Ejectors SEM-C

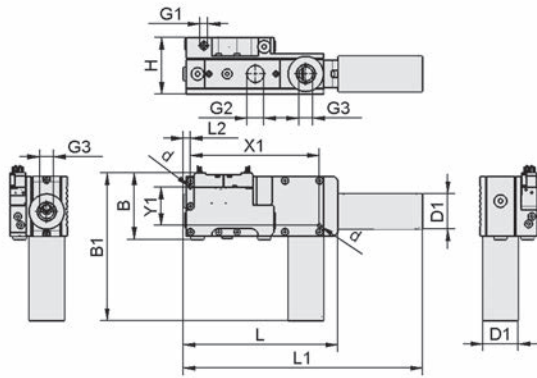

SEM-C SD NO/NC AS

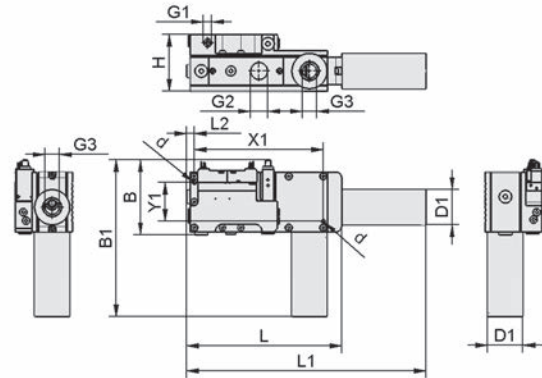

SEM-C SD NO/NC AS VD

Type	B [mm]	B1 [mm]	d [mm]	D1 [mm]	G1	G2	G3	H [mm]	L [mm]	L1 [mm]	L2 [mm]	X1 [mm]	Y1 [mm]
SEM-C 25 SDA NC AS	95	170	5.5	40	G1/4"-F	G1/2"-F	G1/2"-F	70	200	280	11	183	55
SEM-C 25 SDA NO AS	95	170	5.5	40	G1/4"-F	G1/2"-F	G1/2"-F	70	200	280	11	183	55
SEM-C 25 SDA NC AS VD	117	192	5.5	40	G1/4"-F	G1/2"-F	G1/2"-F	70	200	280	11	183	55
SEM-C 25 SDA NO AS VD	117	192	5.5	40	G1/4"-F	G1/2"-F	G1/2"-F	70	200	280	11	183	55
SEM-C 50 SDA NC AS	95	210	5.5	50	G1/4"-F	G3/4"-F	G3/4"-F	80	220	340	11	183	55
SEM-C 50 SDA NO AS	95	210	5.5	50	G1/4"-F	G3/4"-F	G3/4"-F	80	220	340	11	183	55
SEM-C 50 SDA NC AS VD	117	232	5.5	50	G1/4"-F	G3/4"-F	G3/4"-F	80	220	340	11	183	55
SEM-C 50 SDA NO AS VD	117	232	5.5	50	G1/4"-F	G3/4"-F	G3/4"-F	80	220	340	11	183	55
SEM-C 100 SDA NC AS	95	210	5.5	50	G1/4"-F	G1"-F	G3/4"-F	90	220	340	11	183	55
SEM-C 100 SDA NO AS	95	210	5.5	50	G1/4"-F	G1"-F	G3/4"-F	90	220	340	11	183	55
SEM-C 100 SDA NC AS VD	117	232	5.5	50	G1/4"-F	G1"-F	G3/4"-F	90	220	340	11	183	55
SEM-C 100 SDA NO AS VD	117	232	5.5	50	G1/4"-F	G1"-F	G3/4"-F	90	220	340	11	183	55

Schmalz –  
The Company

Vacuum  
Suction Cups

Special  
Grippers

Gripping  
Systems

Clamping  
Systems

Mounting  
Elements

Vacuum  
Generators

Valve  
Technology

Switches and  
Monitoring

Filters and  
Connections

Services

Contact

Glossary

Index of  
Products



# Compact Terminal SCTMi

Flexible, fully networked vacuum generation



- Schmalz – The Company
- Vacuum Suction Cups
- Special Grippers
- Gripping Systems
- Clamping Systems
- Mounting Elements
- Vacuum Generators
- Valve Technology
- Switches and Monitoring
- Filters and Connections
- Services
- Contact
- Glossary
- Index of Products

Variety, optimization of production processes, continuous energy and process control are the challenges of the future. In order to meet these demands, powerful, flexible and energyefficient vacuum systems are required.

The answer is our Compact Terminal SCTMi, a compact unit of several vacuum generators for simultaneously and independently handling different parts with a single vacuum system.



- Central compressed air and power supply for up to 16 ejectors with just one connection each
- Compact design and low weight make it suitable for a wide range of applications

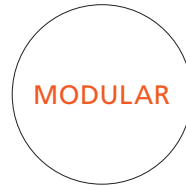

- Modular design means various vacuum circuits can be installed to handle different parts with ease
- Each ejector can be selected based on nozzle size, NO, NC or nozzle type



- Can be integrated in a wide range of fieldbus systems
- Process and device parameters can be easily configured via IO-Link or NFC

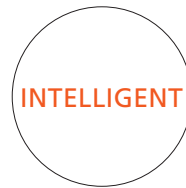

- All vacuum circuits can be controlled separately
- Process transparency, energy consumption control and a variety of diagnostic functions for use in intelligent factories





# Compact Terminal SCTMi

Flexible, fully networked vacuum generation

## Simplified Integration in the Control Level

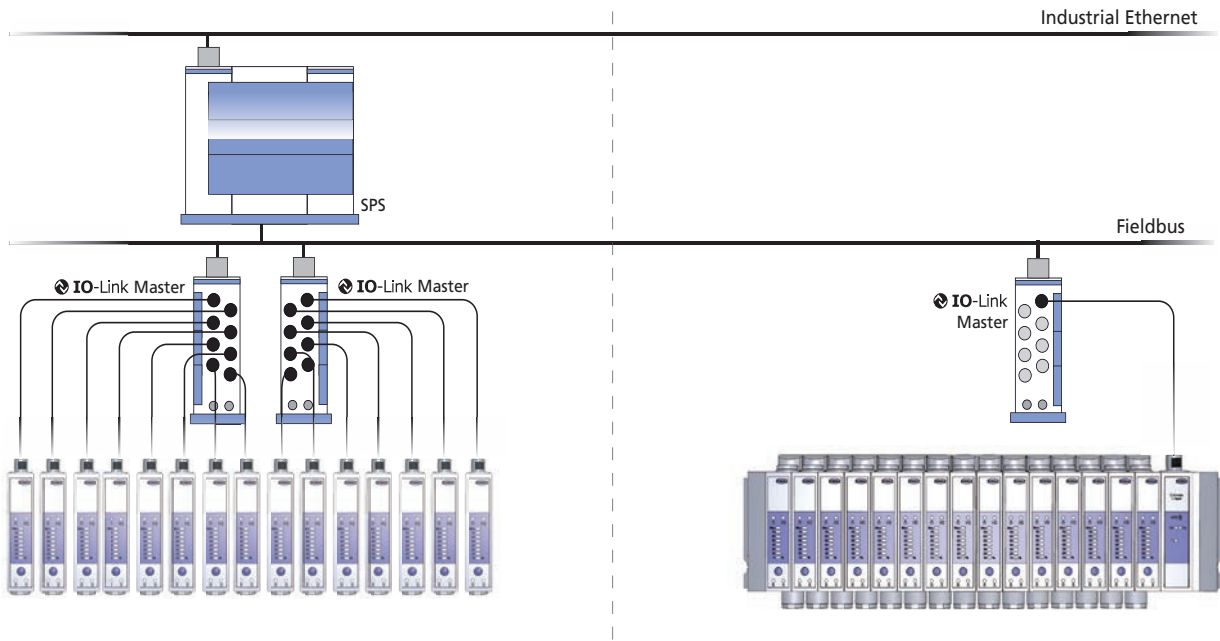

Connecting individual ejectors

Connecting the SCTMi

### Design

- Lean, central compressed air supply (1)
- NFC chip (2) for reading and writing process information
- Central power supply and IO-Link connection  
M12, 5-pin via the control module (3)
- Threaded vacuum connections (5)
- Compact vacuum terminal with max. 16 block-mounted compact ejectors (4)

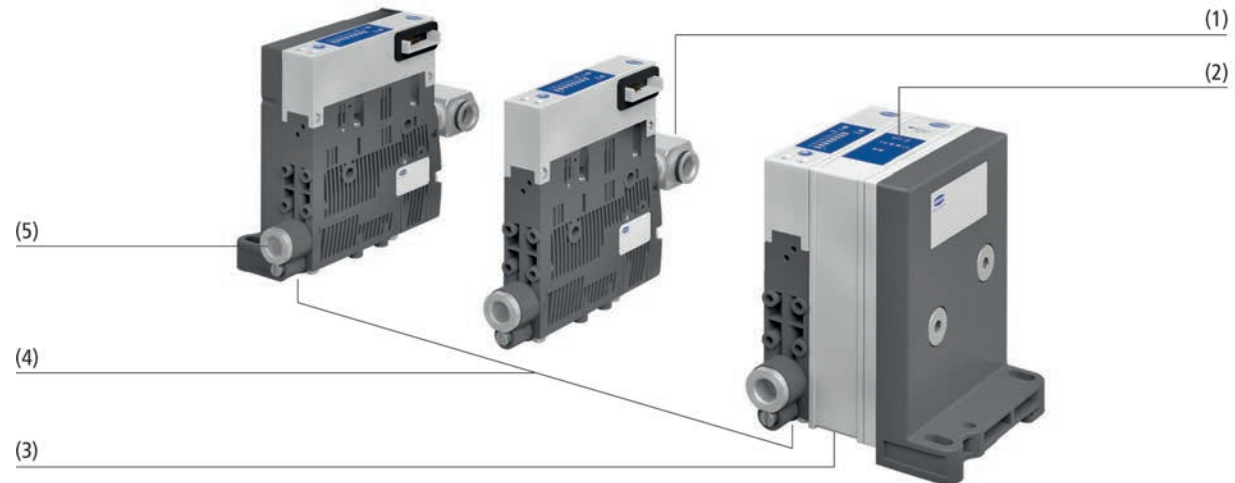

System design Compact Terminal SCTMi

# Compact Terminal SCTMi

Configuration code – Selection and ordering aid

## SCTMi-IOL – 11112



### Main body SCTMi

Code	Type
SCTMi-IOL	SCTMi IO-Link main body

#### Example: SCTMi-IOL01

Main body and IO-Link master element with IO-Link electrical connection using M12, 5-pin plug

### Ejectors

Code*	Type	Part no.
1	SCPSt 07 G02 NO	10.02.02.04676
2	SCPSt 10 G02 NO	10.02.02.04681
3	SCPSt 15 G02 NO	10.02.02.04675
4	SCPSt 07 G02 NC	10.02.02.04673
5	SCPSt 10 G02 NC	10.02.02.04429
6	SCPSt 15 G02 NC	10.02.02.04678

#### Example: 11112200-00000000

4x ejector SCPSt 07 G02 NO (10.02.02.04676) and 2x ejector SCPSt 10 G02 NO (10.02.02.04681)

### Ordering Code Compact Ejectors SCPSt

SCPSt 1	–	2 2	–	07 3	–	G02 4	–	NC 5
------------	---	--------	---	---------	---	----------	---	---------

#### 1 – Abbreviated designation

Code	Version
SCPSt	SCPSt

#### 2 – Nozzle technology

Code	Type
2	2-stage

#### 3 – Nozzle size

Code	Diameter in mm
07	0.7
10	1.0
15	1.5
2-07	0.7
2-09	0.9
2-15	1.4

#### 4 – Connection

Code	Connection
G02	Connection thread 2

#### 5 – Idle valve position

Code	Type
NC	Normally closed
NO	Normally open

Schmalz – The Company  
Vacuum Suction Cups  
Special Grippers  
Gripping Systems  
Clamping Systems  
Mounting Elements  
Vacuum Generators  
Valve Technology  
Switches and Monitoring  
Filters and Connections  
Services  
Contact  
Glossary  
Index of Products

200-00000000

- P



Code*	Type	Part no.
7	SCPSt 2-07 G02 NO	10.02.02.04677
8	SCPSt 2-09 G02 NO	10.02.02.04682
9	SCPSt 2-14 G02 NO	10.02.02.04680
A	SCPSt 2-07 G02 NC	10.02.02.04674
B	SCPSt 2-09 G02 NC	10.02.02.04683
C	SCPSt 2-14 G02 NC	10.02.02.04679

**Note:**

2 to 16 ejectors can be configured. A bigger inner hose diameter for air supply is required by 9 or more ejectors.

\* Each digit represents an ejector position. Unassigned positions are indicated by "0".

**Collective pneumatic connection**

Code	Type
P	With collective pneumatic connection
X	Without collective pneumatic connection

**Example: P**

Collective pneumatic connection for supplying all ejectors with one, two or three compressed air lines

**Sample SCTMi Configuration**

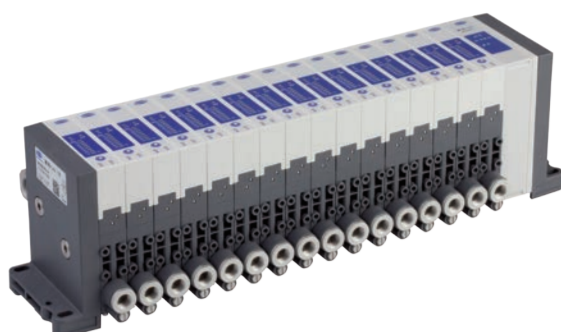

SCTMi-IOL - 88BB88BB-88BB88BB - P

Main body and IO-Link master element with IO-Link connection	8x ejector SCPSt 2-09 G02 NO (10.02.02.04682) and 8x ejector SCPSt 2-09 G02 NC (10.02.02.04683)	Collective pneumatic connection
--------------------------------------------------------------	-------------------------------------------------------------------------------------------------	---------------------------------

Note: Our experienced specialists will assist you in setting up and configuring your terminal. The contact details can be found in the chapter "Contact".



# Compact Terminal SCTMi

## Technical data

### Technical Data Compact Terminal SCTMi (Electronics)

Type	Operating temperature [°C]	Pressure range (operating pressure) [bar]	Electrical connection	Communication
SCTMi-IOL	0...50	2...6	M12, 5-pin plug	IO-Link class B

### Technical Data Compact Ejectors SCPSt

Type	Nozzle size [mm]	Degree of evacuation [%]*	Max. suction rate [m³/h]*	Max. suction rate [l/min]*	Air consumption vacuum [m³/h]*	Air consumption blow off [m³/h]*	Sound level free* [dB(A)]**	Sound level gripped* [dB(A)]**
SCPSt 07...	07	85	0.98	16.0	1.35	7.25	63	58
SCPSt 10...	10	85	2.21	36.0	2.85	7.25	73	60
SCPSt 15...	15	85	4.03	65.5	6.03	7.25	73	65
SCPSt 2-07...	2-07	85	2.28	37.0	1.35	7.25	63	58
SCPSt 2-09...	2-09	85	3.05	49.5	2.49	7.25	73	60
SCPSt 2-14...	2-14	85	4.40	71.5	5.04	7.25	75	65

\*At optimal operating pressure (4 bar)

\*\*No linear increase in sound level with increase in ejector disks

### Design Data Compact Terminal SCTMi

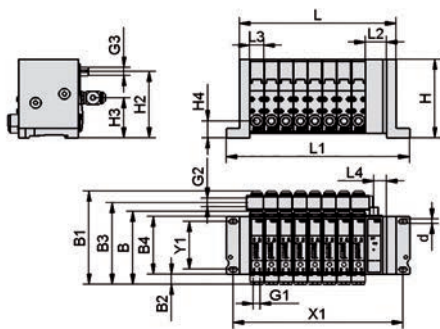

SCTMi-IOL...

Type*	L [mm]	L1 [mm]	L2 [mm]	L3 [mm]	L4 [mm]	B [mm]	B1** [mm]	B2 [mm]	B3** [mm]	B4 [mm]	H [mm]	H2 [mm]	H3 [mm]	H4 [mm]	d [mm]	X1 [mm]	Y1 [mm]	G1	G2	G3	m [g]**
SCTMi-IOL(2)	89,2	123,2	27	18,5	16	97,5	125	13,5	109	77	105	89	54	22,5	5,5	108	64	G1/8"-F	G1/4"-F	M12x1-M	700
SCTMi-IOL(3)	107,7	141,7	27	18,5	16	97,5	125	13,5	109	77	105	89	54	22,5	5,5	125	64	G1/8"-F	G1/4"-F	M12x1-M	910
SCTMi-IOL(4)	126,2	160,2	27	18,5	16	97,5	125	13,5	109	77	105	89	54	22,5	5,5	143	64	G1/8"-F	G1/4"-F	M12x1-M	1.120
SCTMi-IOL(5)	144,7	178,7	27	18,5	16	97,5	125	13,5	109	77	105	89	54	22,5	5,5	162	64	G1/8"-F	G1/4"-F	M12x1-M	1.330
SCTMi-IOL(6)	163,2	197,2	27	18,5	16	97,5	125	13,5	109	77	105	89	54	22,5	5,5	180	64	G1/8"-F	G1/4"-F	M12x1-M	1.540
SCTMi-IOL(7)	181,7	215,7	27	18,5	16	97,5	125	13,5	109	77	105	89	54	22,5	5,5	199	64	G1/8"-F	G1/4"-F	M12x1-M	1.750
SCTMi-IOL(8)	200,2	234,2	27	18,5	16	97,5	125	13,5	109	77	105	89	54	22,5	5,5	217	64	G1/8"-F	G1/4"-F	M12x1-M	1.960
SCTMi-IOL(9)	218,7	252,7	27	18,5	16	97,5	125	13,5	109	77	105	89	54	22,5	5,5	236	64	G1/8"-F	G1/4"-F	M12x1-M	2.170
SCTMi-IOL(10)	237,2	271,2	27	18,5	16	97,5	125	13,5	109	77	105	89	54	22,5	5,5	254	64	G1/8"-F	G1/4"-F	M12x1-M	2.380
SCTMi-IOL(11)	255,7	289,7	27	18,5	16	97,5	125	13,5	109	77	105	89	54	22,5	5,5	273	64	G1/8"-F	G1/4"-F	M12x1-M	2.590
SCTMi-IOL(12)	274,2	308,2	27	18,5	16	97,5	125	13,5	109	77	105	89	54	22,5	5,5	291	64	G1/8"-F	G1/4"-F	M12x1-M	2.800
SCTMi-IOL(13)	292,7	326,7	27	18,5	16	97,5	125	13,5	109	77	105	89	54	22,5	5,5	310	64	G1/8"-F	G1/4"-F	M12x1-M	3.010
SCTMi-IOL(14)	311,2	345,2	27	18,5	16	97,5	125	13,5	109	77	105	89	54	22,5	5,5	328	64	G1/8"-F	G1/4"-F	M12x1-M	3.220
SCTMi-IOL(15)	329,7	363,7	27	18,5	16	97,5	125	13,5	109	77	105	89	54	22,5	5,5	347	64	G1/8"-F	G1/4"-F	M12x1-M	3.430
SCTMi-IOL(16)	348,2	382,2	27	18,5	16	97,5	125	13,5	109	77	105	89	54	22,5	5,5	365	64	G1/8"-F	G1/4"-F	M12x1-M	3.640

\*(2...16) corresponds to the number of installed ejectors

\*\*With compressed air distributor

# Compact Terminal SCTMi

Ideal for use in the smart production of tomorrow

## Highlights of the Compact Terminal SCTMi

The Compact Terminal SCTMi offers an enormous range of innovative, energysaving technologies and networking options for use in intelligent factories. This page introduces you to the most important features.

### Near-Field Communication (NFC)

- Reliable communication via an energyneutral, point-to-point connection
- Visible data – both statistical data (such as the serial number) and dynamic process data (such as switching points) can be read out
- Parameterization option – an app can be used to parameterize the SCTMi directly from a smartphone



### Networking in Industry 4.0 Systems

- The **IO-Link** connection means that recorded data can be viewed and used all the way up to the control level, which allows for bidirectional parameterization and diagnostics in all conventional fieldbus systems
- **Condition monitoring** increases system availability by providing detailed analyses of the system's condition and early detection of faults
- **Predictive maintenance** improves the performance of gripping systems
- **Energy monitoring** optimizes the vacuum systems energy consumption

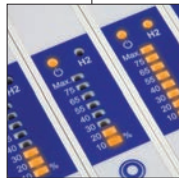

### Automatic Air-Saving Function

- Switches off the suction function once a safe vacuum value has been reached until the next cycle or until the vacuum falls below the safe vacuum value
- Various configuration values and air-saving settings can be programmed separately for each ejector
- Reduction of compressed air consumption by up to 80 %



### Integrated Electronic Sub-Bus System

- Electronic control can be implemented with just a single cable
- Comprehensive data communication via IO-Link and Near-Feld Communication (NFC)
- All ejectors can be separately programmed and controlled

### Eco Nozzle Technology

- Eco nozzle technology provides a considerably higher suction rate with minimized compressed air consumption for energyefficient vacuum generation

# Dry-Running Vacuum Pumps EVE-TR

Suction rate from 2.3 m<sup>3</sup>/h to 244 m<sup>3</sup>/h



## Suitability for Industry Specific Applications

### Applications

- Vacuum pump for universal use in a wide range of different applications in the sector of manual and automatic handling
- Handling of airtight workpieces
- Rapid evacuation of vacuum systems
- Mobile use for picking up and clamping workpieces (EVE-TR-T)

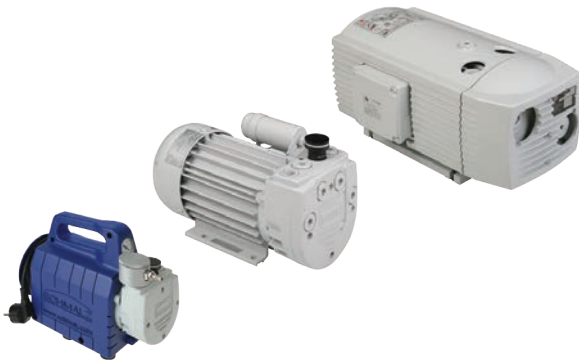

Dry-Running Vacuum Pumps EVE-TR

### Design

- Dry-running vacuum pump, with or without additional filter
- Available in versions for single phase AC, three phase AC or DC power supplies
- Available as a multi cell compressor with very little vibration and constant output or as a compact diaphragm pump
- Compact design with integrated cooling fan and permanently lubricated bearings
- Mounting holes with integrated damping elements
- To be preferably mounted with the motor shaft horizontal

### Our Highlights...

- Dry-running (oil free) vacuum pump
- Multi cell compression principle of the rotary vane pumps
- Permanently lubricated bearings and powerful cooling fan
- Wide range of models with various outputs
- Dry-running rotary vane pump with excellent efficiency

### Your Benefits...

- Robust and requiring little maintenance
- Vibration-free operation and continuous output with little pulsation
- Excellent heat dissipation
- Suction capacity adaptable to meet customer requirements
- Low current consumption, economical continuous operation

- Schmalz – The Company
- Vacuum Suction Cups
- Special Grippers
- Gripping Systems
- Clamping Systems
- Mounting Elements
- Vacuum Generators
- Valve Technology
- Switches and Monitoring
- Filters and Connections
- Services
- Contact
- Glossary
- Index of Products

# Dry-Running Vacuum Pumps EVE-TR

Suction rate from 2.3 m<sup>3</sup>/h to 244 m<sup>3</sup>/h

## Designation Code Dry-Running Vacuum Pumps EVE-TR

<b>EVE</b>	-	<b>TR</b>	-	<b>100</b>	-	<b>AC3</b>	-	<b>IE3-TYP2</b>	-	<b>F</b>
<b>1</b>		<b>2</b>		<b>3</b>		<b>4</b>		<b>5</b>		<b>6</b>

### 1 – Abbreviated designation

Code	Version
EVE	EVE

### 2 – Pump type

Code	Type
TR	Dry-running
TR-M	Diaphragm pump
TR-T	Transportable

### 3 – Performance class

Code	Suction rate in m <sup>3</sup> /h
2.3...250	2.3 to 250

### 4 – Supply voltage

Code	Type
AC	Single phase
AC3	Three phase
DC	Direct current
12V-DC	
24V-DC	

### 5 – Motor type

Code	Region
IE3-TYP1	EU / CN / IND
IE3-TYP2	US / CAN

### 6 – Product addition

Code	Type
F	Additional filter

Vacuum pump EVE-TR is delivered as a ready-to-connect product.

Available spare parts: set of parts subject to wear, filter insert

Available accessories: vacuum regulation valve (vacuum limiter valve)

## Ordering Data Dry-Running Vacuum Pumps EVE-TR

Type	Part no.
EVE-TR-M 2.3 24V-DC	10.03.01.00192
EVE-TR-M 2.3 12V-DC	10.03.01.00195
EVE-TR 4 AC	10.03.01.00120
EVE-TR 4 AC F	10.03.01.00114
EVE-TR 4 AC3	10.03.01.00111
EVE-TR 4 AC3 F	10.03.01.00113
EVE-TR-T 4 AC F	10.03.01.00197
EVE-TR 8 AC	10.03.01.00121
EVE-TR 8 AC F	10.03.01.00117
EVE-TR 8 AC3	10.03.01.00112
EVE-TR 8 AC3 F	10.03.01.00116
EVE-TR 8 DC	10.03.01.00288
EVE-TR 8 24V-DC F	10.03.01.00401
EVE-TR 10 AC	10.03.01.00138
EVE-TR 10 AC F	10.03.01.00144
EVE-TR 10 AC3	10.03.01.00137
EVE-TR 10 AC3 F	10.03.01.00143
EVE-TR 16 AC	10.03.01.00140
EVE-TR 16 AC F	10.03.01.00146
EVE-TR 16 AC3	10.03.01.00139
EVE-TR 16 AC3 F	10.03.01.00145

Type	Part no.
EVE-TR 25 AC3	10.03.01.00141
EVE-TR 25 AC3 F	10.03.01.00147
EVE-TR 25 AC3 IE3-TYP2	10.03.01.00349
EVE-TR 25 AC3 IE3-TYP2 F	10.03.01.00353



Schmalz – The Company  
Vacuum Suction Cups  
Special Grippers  
Gripping Systems  
Clamping Systems  
Mounting Elements  
Vacuum Generators  
Valve Technology  
Switches and Monitoring  
Filters and Connections  
Services  
Contact  
Glossary  
Index of Products

# Dry-Running Vacuum Pumps EVE-TR

Suction rate from 2.3 m<sup>3</sup>/h to 244 m<sup>3</sup>/h



## Ordering Data Dry-Running Vacuum Pumps EVE-TR

Type	Part no.
EVE-TR 40 AC3	10.03.01.00142
EVE-TR 40 AC3 F	10.03.01.00148
EVE-TR 40 AC3 IE3-TYP2	10.03.01.00350
EVE-TR 40 AC3 IE3-TYP2 F	10.03.01.00354
EVE-TR 60 AC3 IE3-TYP1	10.03.01.00319
EVE-TR 60 AC3 IE3-TYP1 F	10.03.01.00335
EVE-TR 60 AC3 IE3-TYP2	10.03.01.00320
EVE-TR 60 AC3 IE3-TYP2 F	10.03.01.00336
EVE-TR 80 AC3 IE3-TYP1	10.03.01.00321
EVE-TR 80 AC3 IE3-TYP1 F	10.03.01.00337
EVE-TR 80 AC3 IE3-TYP2	10.03.01.00322
EVE-TR 80 AC3 IE3-TYP2 F	10.03.01.00338
EVE-TR 100 AC3 IE3-TYP1	10.03.01.00323
EVE-TR 100 AC3 IE3-TYP1 F	10.03.01.00339
EVE-TR 100 AC3 IE3-TYP2	10.03.01.00324
EVE-TR 100 AC3 IE3-TYP2 F	10.03.01.00340
EVE-TR 140 AC3 IE3-TYP1 F	10.03.01.00341
EVE-TR 140 AC3 IE3-TYP2	10.03.01.00326
EVE-TR 140 AC3 IE3-TYP2 F	10.03.01.00342
EVE-TR 250 AC3 IE3-TYP2 F	10.03.01.00328
EVE-TR 140 AC3 IE3-TYP1	10.03.01.00325
EVE-TR 250 AC3 IE3-TYP1 F	10.03.01.00327



## Ordering Data Spare Parts Dry-Running Vacuum Pumps EVE-TR

Type	Spare Parts		Part no.	
EVE-TR 4	4	Set of parts subject to wear pump	VST EVE-TR-4	10.03.01.00108
EVE-TR 8	8	Set of parts subject to wear pump	VST EVE-TR-8	10.03.01.00109
EVE-TR 10	10	Set of parts subject to wear pump	VST EVE-TR-10	10.03.01.00132
EVE-TR 16	16	Set of parts subject to wear pump	VST EVE-TR-16	10.03.01.00133
EVE-TR 25	25	Set of parts subject to wear pump	VST EVE-TR-25	10.03.01.00134
EVE-TR 40	40	Set of parts subject to wear pump	VST EVE-TR-40	10.03.01.00135
EVE-TR 60	60	Set of parts subject to wear pump	VST EVE-TR60/TR80	22.09.01.00031
EVE-TR 80	80	Set of parts subject to wear pump	VST EVE-TR60/TR80	22.09.01.00031
EVE-TR 100	100	Set of parts subject to wear pump	VST EVE-TR-100	22.09.01.00033
EVE-TR 140	140	Set of parts subject to wear pump	VST EVE-TR-140	22.09.01.00035
EVE-TR 250	250	Set of parts subject to wear pump	VST EVE-TR-360	10.03.01.00187

Type	Spare Parts		Part no.	
EVE-TR 4	4	Filter insert (round)	FILT-EINS 15 27x23 A2 VF-1/4-Draht	10.07.01.00013
EVE-TR 8	8	Filter insert (round)	FILT-EINS 10 28x51 PAP VF-3/8	10.07.01.00014
EVE-TR 10	10	Filter insert (round)	FILT-EINS 3 65x70 PAP STF-3/4-IG	10.07.01.00017
EVE-TR 16	16	Filter insert (round)	FILT-EINS 3 65x70 PAP STF-3/4-IG	10.07.01.00017
EVE-TR 25	25	Filter insert (round)	FILT-EINS 3 65x70 PAP STF-3/4-IG	10.07.01.00017
EVE-TR 40	40	Filter insert (round)	FILT-EINS 3 98x70 PAP STF-1-1/4-IGN	10.07.01.00018
EVE-TR 80	80	Filter insert (round)	FILT-EINS 3 98x70 PAP STF-1-1/4-IGN	10.07.01.00018
EVE-TR 100	100	Filter insert (round)	FILT-EINS 3 98x70 PAP STF-1-1/4-IGN	10.07.01.00018
EVE-TR 140	140	Filter insert (round)	FILT-EINS 3 98x70 PAP STF-1-1/4-IGN	10.07.01.00018





# Dry-Running Vacuum Pumps EVE-TR

Suction rate from 2.3 m<sup>3</sup>/h to 244 m<sup>3</sup>/h

## Ordering Data Accessories Dry-Running Vacuum Pumps EVE-TR

Type	Accessories	Part no.
EVE-TR 4	Vacuum limiter valve VBV -850...0 G3/8-AG EVE 4-8	10.03.01.00107
EVE-TR 8	Vacuum limiter valve VBV -850...0 G3/8-AG EVE 4-8	10.03.01.00107
EVE-TR 10	Vacuum limiter valve VBV -950...0 G1-AG EVE 10-40	10.03.01.00136
EVE-TR 16	Vacuum limiter valve VBV -950...0 G1-AG EVE 10-40	10.03.01.00136
EVE-TR 25	Vacuum limiter valve VBV -950...0 G1-AG EVE 10-40	10.03.01.00136
EVE-TR 40	Vacuum limiter valve VBV -950...0 G1-AG EVE 10-40	10.03.01.00136
EVE-TR 80	Vacuum limiter valve VBV -950...0 G1-1/4-AG EVE 80-140	10.03.01.00153
EVE-TR 100	Vacuum limiter valve VBV -950...0 G1-1/4-AG EVE 80-140	10.03.01.00153
EVE-TR 140	Vacuum limiter valve VBV -950...0 G1-1/4-AG EVE 80-140	10.03.01.00153



## Technical Data Dry-Running Vacuum Pumps EVE-TR

Type	Motortype 1 (+/- 10%) EVE-TR 25 – 140	Motortype 1 (+/- 10%) EVE-TR 250	Motortype 2 (+/- 10%) EVE-TR 25 – 250	Motortype 3 (+/- 10%) EVE-TR 25 – 250
50Hz with IE3	230V / Y400V	400V	-	200V / Y350V
60Hz with IE3	265V / Y460V	460V	YY230V / Y460V	220V / Y380-400V
60Hz without IE3	230V / Y400V	400V	YY208V	200V / Y350V

Type*	Vacuum (50 Hz) [mbar]	Suction rate at DC [m <sup>3</sup> /h]	Suction rate (50 Hz) [m <sup>3</sup> /h]	Suction capacity (60 Hz) [m <sup>3</sup> /h]	Voltage	Protection type IP	Weight [kg]	Sound level at 50 Hz [dB(A)]
EVE-TR-M 2.3 12V-DC	-	2.0	-	-	12V - DC V	-	2.4	-
EVE-TR-M 2.3 24V-DC	-	2.0	-	-	24V - DC V	-	2.4	-
EVE-TR 4 AC	-850	-	4.1	4.7	-	54	7.0	59
EVE-TR 4 AC3	-850	-	4.1	4.7	-	54	7.0	59
EVE-TR-T 4 AC F	-	-	4.0	4.7	-	54	8.5	59
EVE-TR 8 AC	-850	-	7.6	8.7	-	54	11.5	58
EVE-TR 8 AC3	-850	-	7.6	8.7	-	54	11.5	58
EVE-TR 8 DC	-	9.7	-	-	24V - DC V	-	12.0	61
EVE-TR 10 AC	-850	-	10.0	12.0	-	54	16.0	60
EVE-TR 10 AC3	-850	-	10.0	12.0	-	54	16.0	60
EVE-TR 16 AC	-850	-	16.0	19.0	-	54	22.4	61
EVE-TR 16 AC3	-850	-	16.0	19.0	-	54	22.4	61
EVE-TR 25 AC3	-850	-	25.0	30.0	-	54	26.0	62
EVE-TR 40 AC3	-850	-	40.0	48.0	-	55	38.5	67
EVE-TR 80 AC3/S072 IE2	-900	-	67.0	78.5	-	55	78.0	72
EVE-TR 100 AC3/S070 IE2	-900	-	98.0	112.0	-	55	100.0	75
EVE-TR 140 AC3/S072 IE2	-900	-	129.0	154.0	-	55	111.0	76
EVE-TR 250 AC3 F	-800	-	244.0	286.0	-	55	222.0	77

\*Specifications for 230 V / 230 V or 400 V



# Dry-Running Vacuum Pumps EVE-TR

Suction rate from 2.3 m<sup>3</sup>/h to 244 m<sup>3</sup>/h

## Performance Data Dry-Running Vacuum Pumps EVE-TR

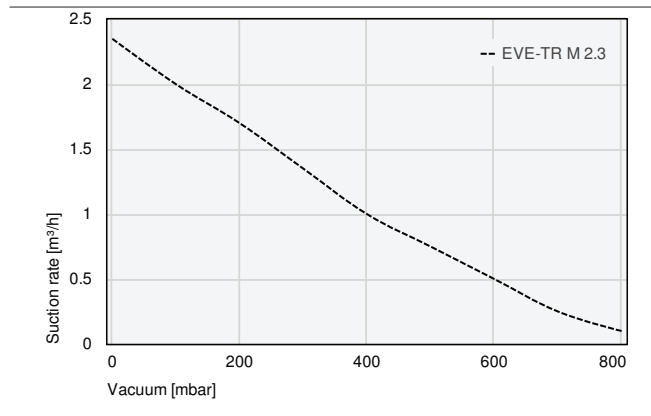

Suction capacity at various degrees of evacuation

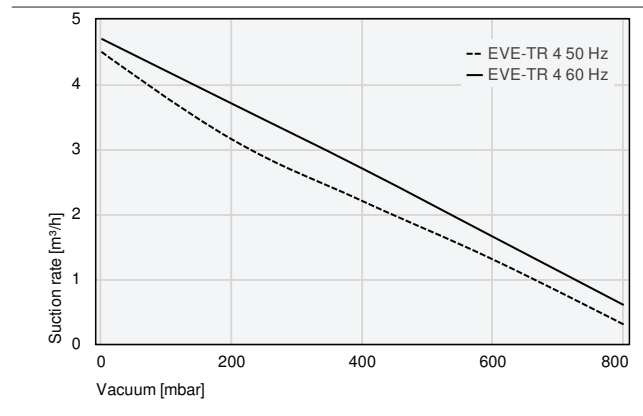

Suction capacity at various degrees of evacuation

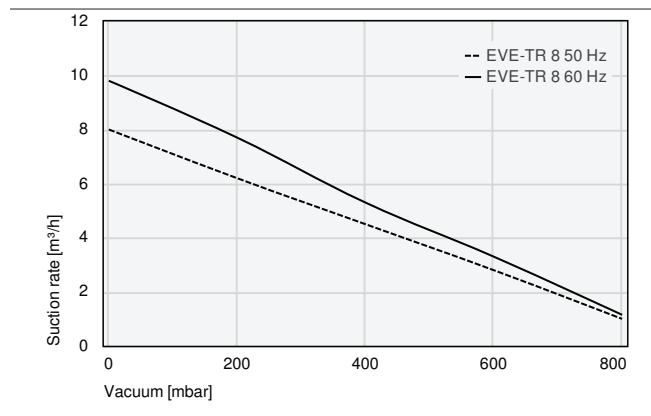

Suction capacity at various degrees of evacuation

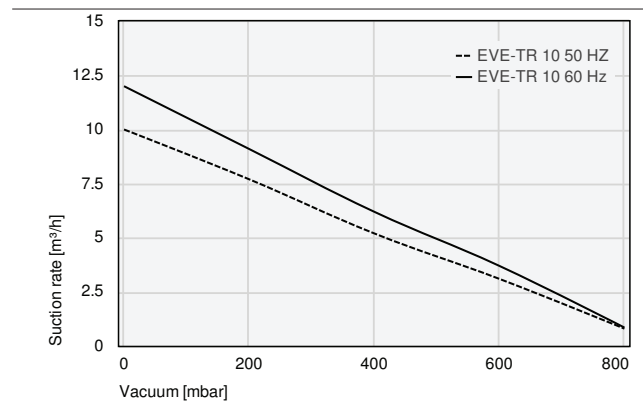

Suction capacity at various degrees of evacuation

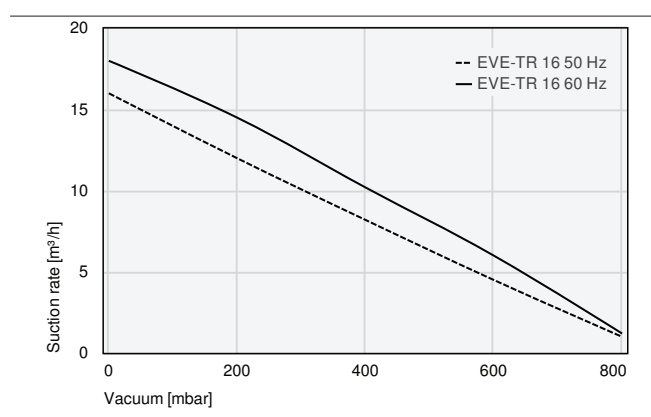

Suction capacity at various degrees of evacuation

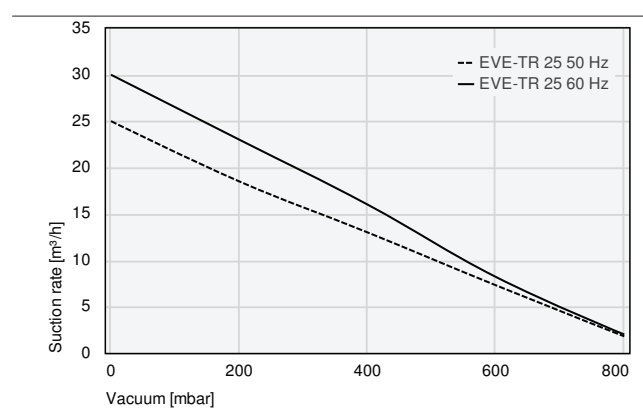

Suction capacity at various degrees of evacuation

- Schmalz - The Company
- Vacuum Suction Cups
- Special Grippers
- Gripping Systems
- Clamping Systems
- Mounting Elements
- Vacuum Generators
- Valve Technology
- Switches and Monitoring
- Filters and Connections
- Services
- Contact
- Glossary
- Index of Products

# Dry-Running Vacuum Pumps EVE-TR



Suction rate from 2.3 m<sup>3</sup>/h to 244 m<sup>3</sup>/h



## Performance Data Dry-Running Vacuum Pumps EVE-TR

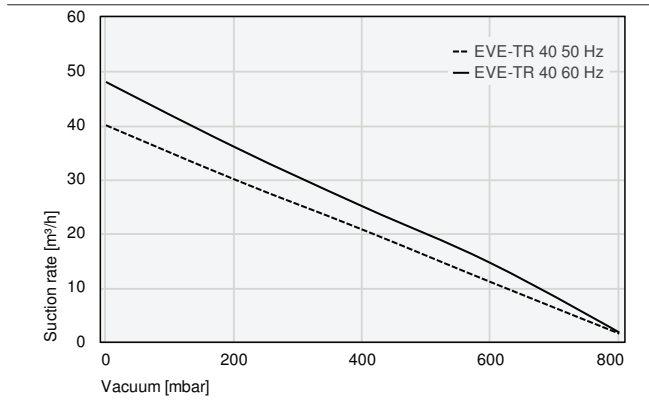

Suction capacity at various degrees of evacuation

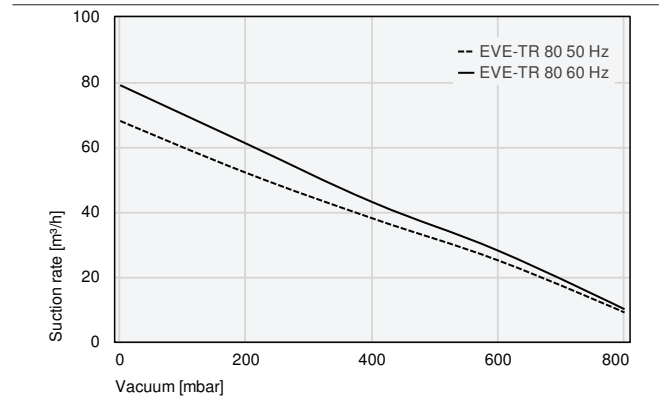

Suction capacity at various degrees of evacuation

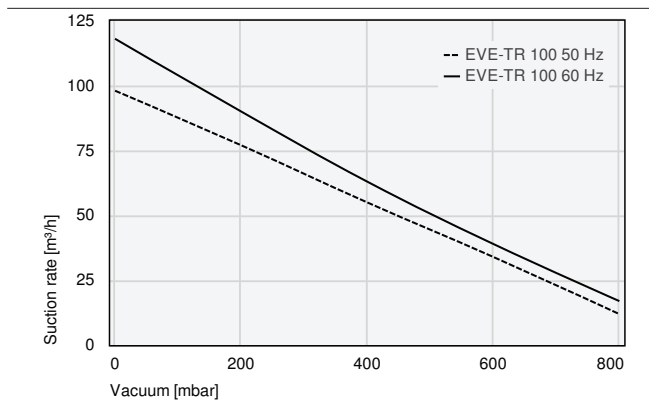

Suction capacity at various degrees of evacuation

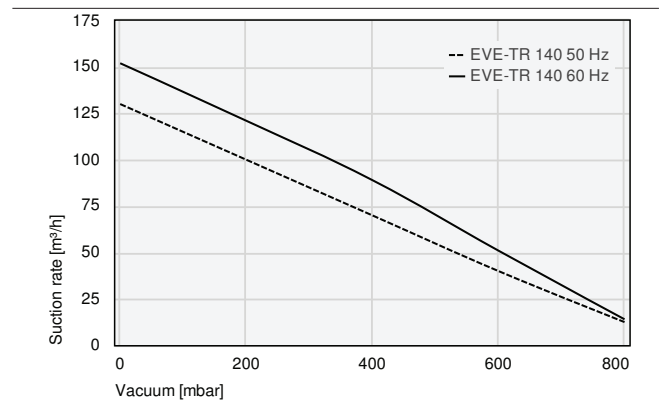

Suction capacity at various degrees of evacuation

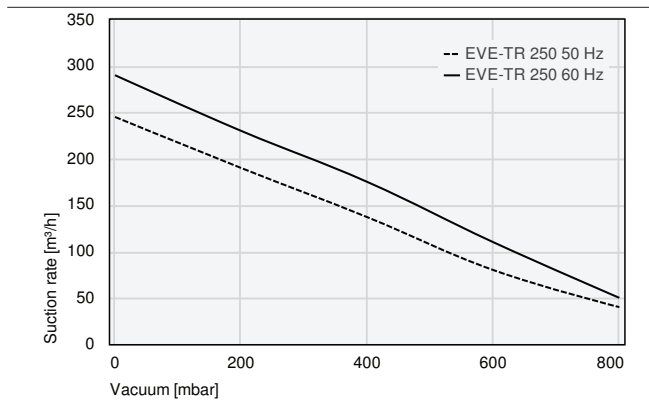

Suction capacity at various degrees of evacuation

- Schmalz – The Company
- Vacuum Suction Cups
- Special Grippers
- Gripping Systems
- Clamping Systems
- Mounting Elements
- Vacuum Generators
- Valve Technology
- Switches and Monitoring
- Filters and Connections
- Services
- Contact
- Glossary
- Index of Products



# Dry-Running Vacuum Pumps EVE-TR

Suction rate from 2.3 m<sup>3</sup>/h to 244 m<sup>3</sup>/h

**Design Data Dry-Running Vacuum Pumps EVE-TR**

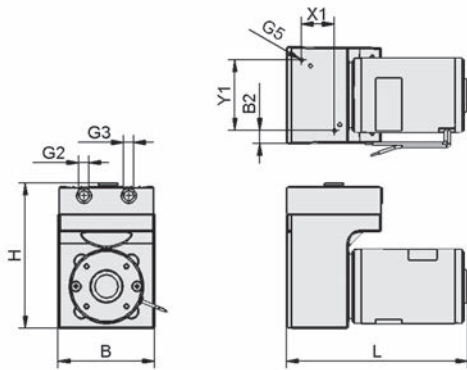

EVE-TR-M 2.3

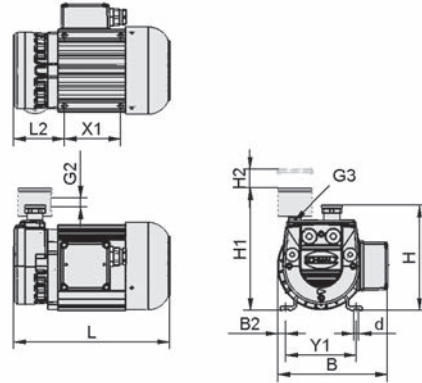

EVE-TR 4 - 8 (F)

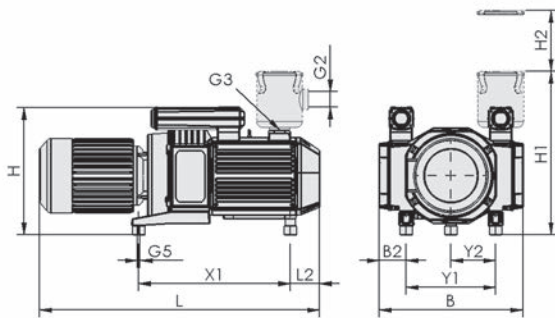

EVE-TR 250

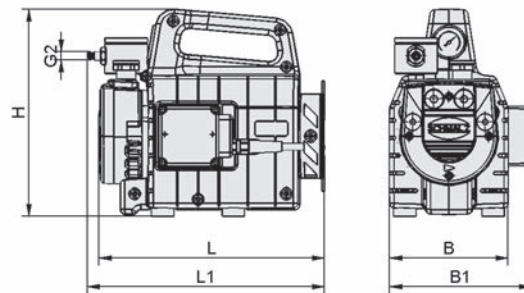

EVE-TR-T

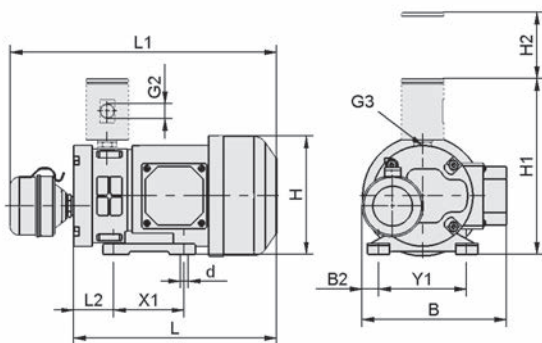

EVE-TR 8 DC (F)

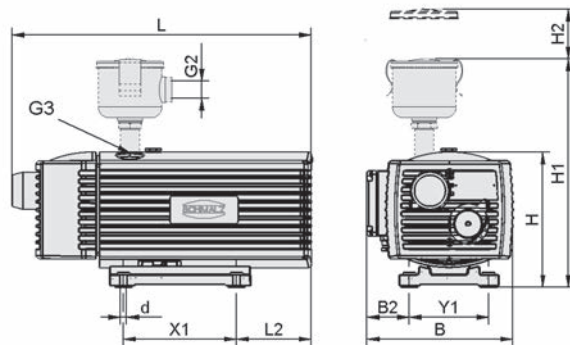

EVE-TR 10 - 40 (F)

Schmalz - The Company  
Vacuum Suction Cups  
Special Grippers  
Gripping Systems  
Clamping Systems  
Mounting Elements  
Vacuum Generators  
Valve Technology  
Switches and Monitoring  
Filters and Connections  
Services  
Contact  
Glossary  
Index of Products

# Dry-Running Vacuum Pumps EVE-TR

Suction rate from 2.3 m<sup>3</sup>/h to 244 m<sup>3</sup>/h



## Design Data Dry-Running Vacuum Pumps EVE-TR

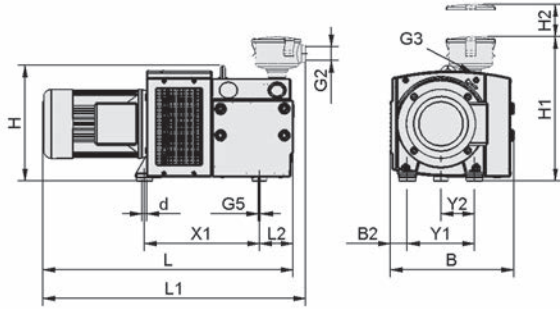

EVE-TR 80 - 140 (F)

Type			B	B1	B2	d		G2	G3	G5	H	H1	H2	L	L1	L2	X1	Y1	Y2
			[mm]	[mm]	[mm]	[mm]					[mm]	[mm]	[mm]	[mm]	[mm]	[mm]	[mm]	[mm]	[mm]
EVE-TR	3	-	82	-	11	-	-	G1/8"-F	G1/8"-F	M4-F	123	-	-	154	-	-	28	60	-
EVE-TR	4	AC3	155	-	12	7	-	-	G1/4-F	-	148	-	-	222	-	72	80	100	-
EVE-TR	4	AC	155	-	12	7	-	G1/4-F	G1/4-F	-	148	172	41	222	-	72	80	100	-
EVE-TR	4	AC	134	161	-	-	-	G1/4"-M	-	-	235	-	-	255	269	-	-	-	-
EVE-TR	8	AC	155	-	12	7	-	-	G3/8-F	-	172	-	-	251	-	80	80	100	-
EVE-TR	8	AC	155	-	12	7	-	G3/8-F	G3/8-F	-	154	201	62	251	-	80	80	100	-
EVE-TR	8	AC3	155	-	12	7	-	G3/8-F	G3/8-F	-	154	201	62	231	-	80	80	100	-
EVE-TR	8	DC	136	-	8	9	-	-	G3/8"-F	-	196	-	-	231	-	72	80	100	-
EVE-TR	10	AC3	206	-	60	7	-	-	G1/2-F	-	195	-	-	429	-	106	160	112	-
EVE-TR	10	AC3	206	-	60	7	-	G3/4-F	G1/2-F	-	198	325	70	429	-	106	160	112	-
EVE-TR	16	AC	231	-	66	7	-	-	G1/2-F	-	211	-	-	452	-	73	202	125	-
EVE-TR	16	AC	231	-	66	7	-	G3/4-F	G1/2-F	-	214	345	70	452	-	73	202	125	-
EVE-TR	25	AC3	260	-	40	7	-	-	G3/4"-F	-	290	-	-	505	-	96	220	190	-
EVE-TR	25	AC3	260	-	40	7	-	G3/4"-F	G3/4"-F	-	293	380	70	505	-	96	220	208	-
EVE-TR	40	AC3	280	-	51	7	-	-	G3/4"-F	-	290	-	-	572	-	131	220	190	-
EVE-TR	40	AC3	280	-	51	7	-	G1-1/4"-F	G3/4"-F	-	293	425	70	572	-	131	220	190	-
EVE-TR	80	AC3	353	-	48	12	-	-	G1"-F	M8-F	328	-	-	709	-	96	326	190	95
EVE-TR	80	AC3	353	-	48	12	-	G1-1/4"-F	G1"-F	M8-F	328	420	75	709	745	96	326	190	95
EVE-TR	100	AC3	470	-	110	12	-	-	G1-1/2"-F	M8-F	336	-	-	835	-	140	398	245	123
EVE-TR	100	AC3	470	-	110	12	-	G1-1/4"-F	G1-1/2"-F	M8-F	336	466	75	835	890	140	398	245	123
EVE-TR	140	AC3	470	-	110	12	-	-	G1-1/2"-F	M8-F	336	-	-	873	-	140	398	245	123
EVE-TR	140	AC3	470	-	110	12	-	G1-1/4"-F	G1-1/2"-F	M8-F	336	437	75	873	851	140	398	245	123
EVE-TR	250	AC3	644	-	116	-	-	-	G2-1/2"-F	M10-F	530	-	-	1,059	-	124	645	380	190

Schmalz – The Company

Vacuum Suction Cups

Special Grippers

Gripping Systems

Clamping Systems

Mounting Elements

Vacuum Generators

Valve Technology

Switches and Monitoring

Filters and Connections

Services

Contact

Glossary

Index of Products



# Dry-Running Vacuum Pumps EVE-TR X

Suction rate from 10 m<sup>3</sup>/h to 129 m<sup>3</sup>/h



## Suitability for Industry Specific Applications

### Applications

- Vacuum pump for a wide variety of applications in automatic and manual handling
- Handling of airtight workpieces
- Rapid evacuation of vacuum systems



Dry-Running Vacuum Pumps EVE-TR X

### Design

- Vacuum pump in a dry-running design with or without an additional filter
- In a three phase version
- Pump acting as a sliding vane compressor with especially vibration free operation and constant feed volumes
- Compact design with integrated fan and permanently lubricated bearing
- Mounting hole with integrated damping element
- Installation position preferable horizontally with the motor shaft

### Our Highlights...

- Fully honed housing and gate valve made from resin bonded carbon
- Sliding vane compressor principle of the rotary vane pumps
- Permanently lubricated bearings and high performance fan
- Wide area of application

### Your Benefits...

- Significantly longer rotary vane service life
- Vibration free operation and continuous low pulsation conveyance
- Outstanding heat removal
- Adaptable suction capacity

- Schmalz – The Company
- Vacuum Suction Cups
- Special Grippers
- Gripping Systems
- Clamping Systems
- Mounting Elements
- Vacuum Generators
- Valve Technology
- Switches and Monitoring
- Filters and Connections
- Services
- Contact
- Glossary
- Index of Products



# Oil-Lubricated Vacuum Pumps EVE-OG

Suction rate from 10 m<sup>3</sup>/h to 255 m<sup>3</sup>/h



## Suitability for Industry Specific Applications



Oil-Lubricated Vacuum Pumps EVE-OG

### Applications

- Vacuum pump for universal use in a wide range of different applications in the sector of manual and automatic handling
- Handling of airtight and porous workpieces
- For use as a central vacuum generator with high maximum vacuum

### Design

- Oil-lubricated vacuum pump with integrated oil separator, three phase power supply, optionally available with additional filter and motor protection circuit
- Multi vane rotary vacuum pump with constant, low pulsation output; very little vibration
- Compact design with integrated cooling fan and permanently lubricated bearings

### Our Highlights...

- Oil-lubricated vacuum pump
- Multi vane rotary pump
- Permanently lubricated bearings; powerful cooling fan
- Wide range of models with various outputs

### Your Benefits...

- Robust; with very little maintenance; almost constant vacuum generation at high vacuum values
- Vibration free operation and continuous, low pulsation output
- Excellent heat dissipation
- Input volume flow rate can be adapted to meet customer requirements



## Designation Code Oil-Lubricated Vacuum Pumps EVE-OG



#### 1 – Abbreviated designation

Code	Version
EVE	EVE

#### 2 – Pump type

Code	Type
OG	Oil-lubricated

#### 3 – Performance class

Code	Suction rate in m <sup>3</sup> /h
10...255	10 to 255

#### 4 – Supply voltage

Code	Type
AC3	Three phase

#### 5 – Product addition

Code	Type
F	Additional filter

Vacuum pump EVE-OG is delivered as a ready-to-connect product.

Available spare parts: filter cartridge (filter insert), replacement oil, maintenance kit (set of parts subject to wear pump)

Available accessories: motor-protection switch, filter resistance gauge (pressure manometer)



Schmalz – The Company  
Vacuum Suction Cups  
Special Grippers  
Gripping Systems  
Clamping Systems  
Mounting Elements  
Vacuum Generators  
Valve Technology  
Switches and Monitoring  
Filters and Connections  
Services  
Contact  
Glossary  
Index of Products

# Oil-Lubricated Vacuum Pumps EVE-OG

Suction rate from 10 m<sup>3</sup>/h to 255 m<sup>3</sup>/h



## Ordering Data Oil-Lubricated Vacuum Pumps EVE-OG

Type*	Part no.
EVE-OG 10 AC3	10.03.02.00067
EVE-OG 10 AC3 F	10.03.02.00082
EVE-OG 16 AC3	10.03.02.00047
EVE-OG 16 AC3 F	10.03.02.00083
EVE-OG 25 AC3	10.03.02.00084
EVE-OG 25 AC3 F	10.03.02.00020
EVE-OG 40 AC3	10.03.02.00026
EVE-OG 40 AC3 F	10.03.02.00031
EVE-OG 63 AC3	10.03.02.00027
EVE-OG 63 AC3 F	10.03.02.00032
EVE-OG 100 AC3	10.03.02.00028
EVE-OG 100 AC3 F	10.03.02.00033
EVE-OG 165 AC3	10.03.02.00048
EVE-OG 165 AC3 F	10.03.02.00049
EVE-OG 255 AC3	10.03.02.00051
EVE-OG 255 AC3 F	10.03.02.00052

\*Motorprotection with thermoelement as standard



## Ordering Data Spare Parts Oil-Lubricated Vacuum Pumps EVE-OG

Type*	Part no.
Oil	OEL EVE-OG 1L ANDEROL 555 27.02.01.00055
Oil	OEL EVE-OG 5L ANDEROL 555 27.02.01.00056

\*EVE-OG 10-40: 1 ltr., EVE-OG 63-100: 2 ltr., EVE-OG 165-255: 7 ltr. | 27.02.01.00055: 1 ltr., 27.02.01.00056: 5 ltr.

Type	Spare Parts	Part no.
EVE-OG 10	Set of parts subject to wear pump	VST EVE-OG-10-16C 10.03.02.00075
EVE-OG 16	Set of parts subject to wear pump	VST EVE-OG-10-16C 10.03.02.00075
EVE-OG 25	Set of parts subject to wear pump	VST EVE-OG-25-40 10.03.02.00060
EVE-OG 40	Set of parts subject to wear pump	VST EVE-OG-25-40 10.03.02.00060
EVE-OG 63	Set of parts subject to wear pump	VST EVE-OG-63-100 10.03.02.00055
EVE-OG 100	Set of parts subject to wear pump	VST EVE-OG-63-100 10.03.02.00055
EVE-OG 165	Set of parts subject to wear pump	VST EVE-OG-165-255 10.03.02.00057
EVE-OG 255	Set of parts subject to wear pump	VST EVE-OG-165-255 10.03.02.00057

Type	Spare Parts	Part no.
EVE-OG 10	Filter insert (round)	FILT-EINS 3 65x70 PAP STF-3/4-IG 10.07.01.00017
EVE-OG 16	Filter insert (round)	FILT-EINS 3 65x70 PAP STF-3/4-IG 10.07.01.00017
EVE-OG 25	Filter insert (round)	FILT-EINS 3 65x70 PAP STF-3/4-IG 10.07.01.00017
EVE-OG 40	Filter insert (round)	FILT-EINS 3 98x70 PAP STF-1-1/4-IGN 10.07.01.00018
EVE-OG 63	Filter insert (round)	FILT-EINS 3 98x70 PAP STF-1-1/4-IGN 10.07.01.00018
EVE-OG 100	Filter insert (round)	FILT-EINS 3 98x70 PAP STF-1-1/4-IGN 10.07.01.00018
EVE-OG 165	Filter insert (round)	FILT-EINS 3 150x222 PAP STF-2-1/2-IG 10.07.01.00020
EVE-OG 255	Filter insert (round)	FILT-EINS 3 150x222 PAP STF-2-1/2-IG 10.07.01.00020



Schmalz - The Company  
Vacuum Suction Cups  
Special Grippers  
Gripping Systems  
Clamping Systems  
Mounting Elements  
Vacuum Generators  
Valve Technology  
Switches and Monitoring  
Filters and Connections  
Services  
Contact  
Glossary  
Index of Products



# Oil-Lubricated Vacuum Pumps EVE-OG

Suction rate from 10 m<sup>3</sup>/h to 255 m<sup>3</sup>/h



## Ordering Data Accessories Oil-Lubricated Vacuum Pumps EVE-OG

Type	Accessories	Part no.
EVE-OG 10	Motor-protection switch MSS-K 1-1.6A	10.04.04.00118
EVE-OG 16	Motor-protection switch MSS-K 1.6-2.5A	10.04.04.00119
EVE-OG 25	Motor-protection switch MSS-K 2.5-4A	10.04.04.00120
EVE-OG 40	Motor-protection switch MSS-K 2.5-4A	10.04.04.00120
EVE-OG 63	Motor-protection switch MSS-K 4-6.3A	10.04.04.00121
EVE-OG 100	Motor-protection switch MSS-K 6.3-10A	10.04.04.00122
EVE-OG 165	Motor-protection switch MSS-K 8-12A	10.04.04.00123
EVE-OG 255	Motor-protection switch MSS-K 10-16A	10.04.04.00124

Type	Accessories	Part no.
EVE-OG 10	Pressure manometer DRM 40 P1 H	10.07.02.00050
EVE-OG 16	Pressure manometer DRM 40 P1 H	10.07.02.00050
EVE-OG 25	Pressure manometer DRM 40 P1 H	10.07.02.00050
EVE-OG 40	Pressure manometer DRM 40 P1 H	10.07.02.00050
EVE-OG 63	Pressure manometer DRM 40 P1 H	10.07.02.00050
EVE-OG 165	Pressure manometer DRM 40 P1 H	10.07.02.00051
EVE-OG 255	Pressure manometer DRM 40 P1 H	10.07.02.00051



## Technical Data Oil-Lubricated Vacuum Pumps EVE-OG

Type	Max. vacuum [mbar]	Suction rate (50 Hz) [m <sup>3</sup> /h]	Voltage 50 Hz	Current range 50 Hz	Rated power 50 Hz [kW]	Protection type IP	Weight [kg]	Sound level at 50 Hz [dB(A)]
EVE-OG 10 AC3	-980	10	230/400V AC V	1,9A o. 1,1A	0.37	54	19	49
EVE-OG 16 AC3	-980	16	230/400V AC V	2,8A o. 1,6A	0.56	54	19	53
EVE-OG 25 AC3	-980	25	230/400V AC V	3,2A o. 1,86A	0.75	54	34	60
EVE-OG 40 AC3	-980	40	230/400±10% V	4,8A o. 2,8A	1.11	54	38	64
EVE-OG 63 AC3	-980	63	230/400±10% V	6,2A o. 3,6A	1.50	54	52	65
EVE-OG 100 AC3	-980	100	230/400±10% V	8,8A o. 5,0A	2.21	54	70	67
EVE-OG 165 AC3	-980	165	200-240V or 345-420V V	16,6A o. 9,6A	4.00	54	160	70
EVE-OG 255 AC3	-980	255	200-240V or 345-420V V	23,8A o. 13,8A	5.50	54	195	72



# Oil-Lubricated Vacuum Pumps EVE-OG

Suction rate from 10 m<sup>3</sup>/h to 255 m<sup>3</sup>/h

## Performance Data Oil-Lubricated Vacuum Pumps EVE-OG

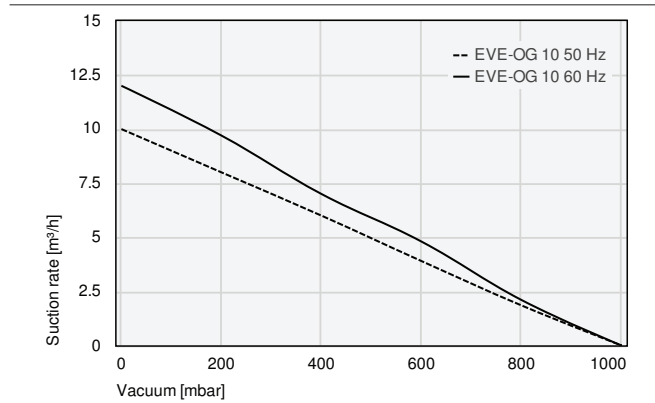

Suction capacity at various degrees of evacuation

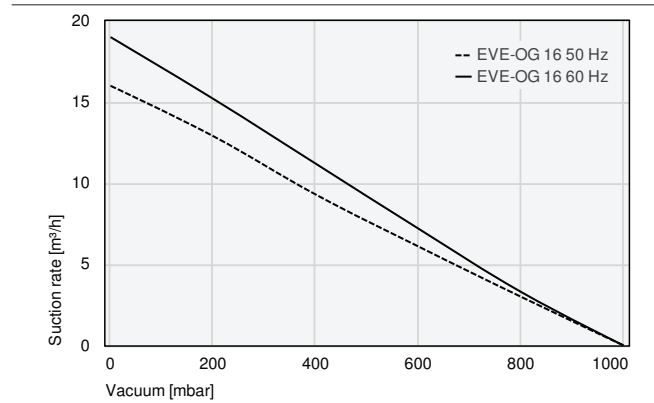

Suction capacity at various degrees of evacuation

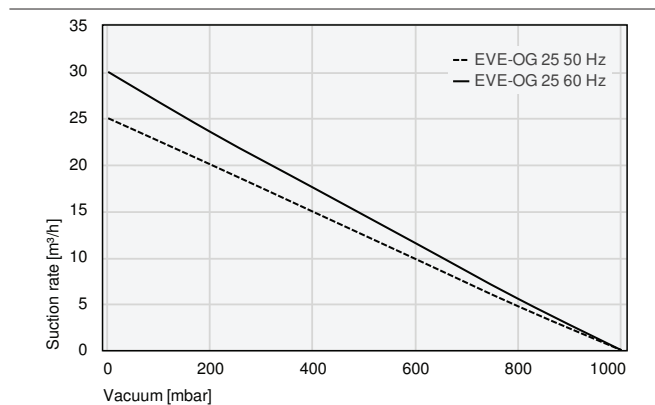

Suction capacity at various degrees of evacuation

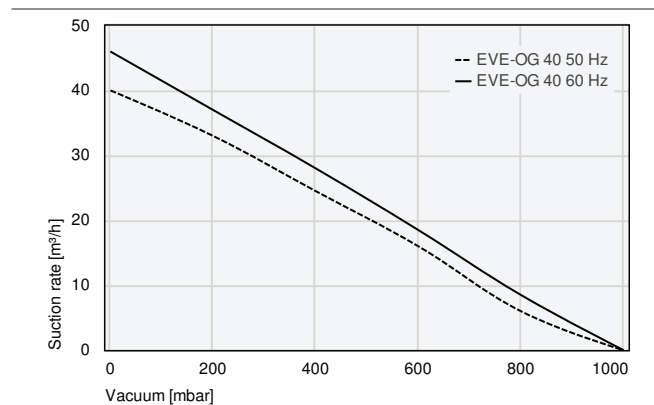

Suction capacity at various degrees of evacuation

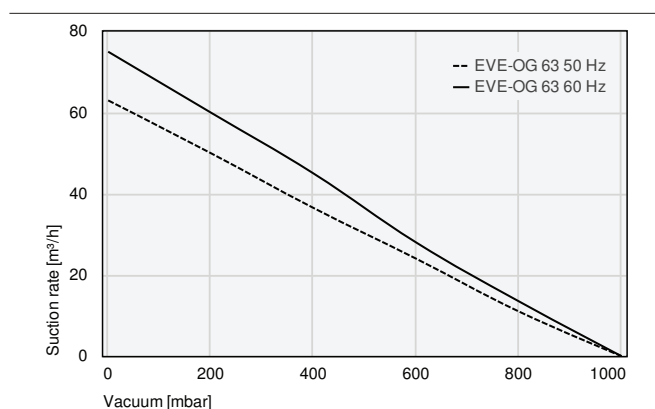

Suction capacity at various degrees of evacuation

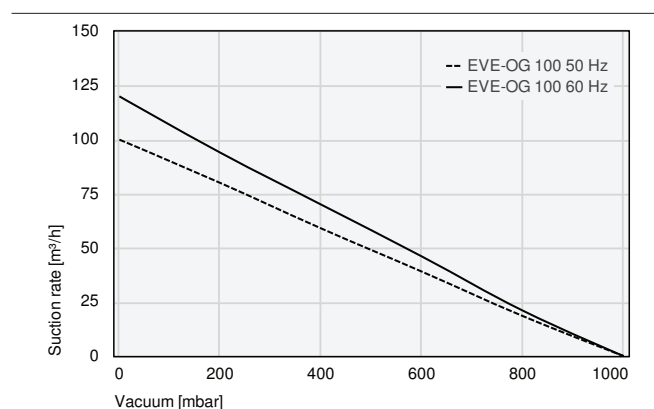

Suction capacity at various degrees of evacuation

- Schmalz – The Company
- Vacuum Suction Cups
- Special Grippers
- Gripping Systems
- Clamping Systems
- Mounting Elements
- Vacuum Generators
- Valve Technology
- Switches and Monitoring
- Filters and Connections
- Services
- Contact
- Glossary
- Index of Products

# Oil-Lubricated Vacuum Pumps EVE-OG

Suction rate from 10 m<sup>3</sup>/h to 255 m<sup>3</sup>/h



## Performance Data Oil-Lubricated Vacuum Pumps EVE-OG

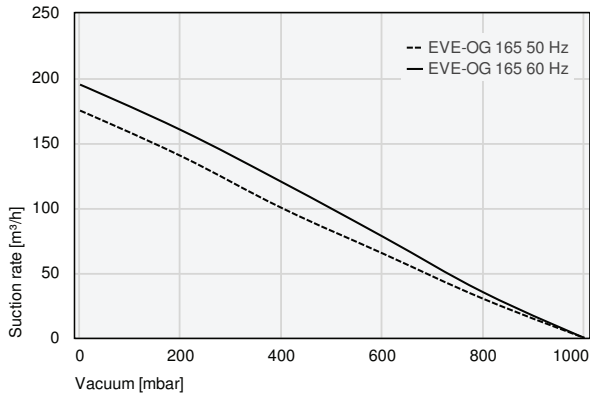

Suction capacity at various degrees of evacuation

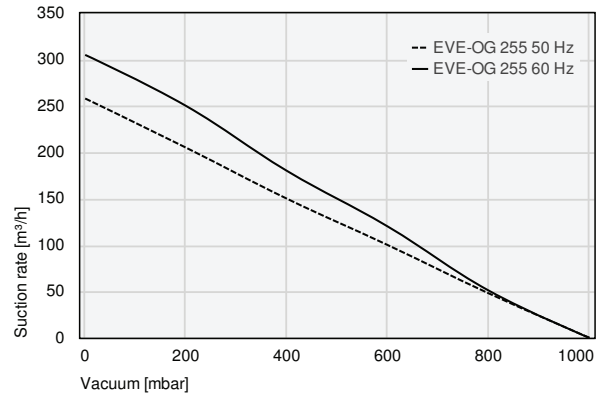

Suction capacity at various degrees of evacuation



## Design Data Oil-Lubricated Vacuum Pumps EVE-OG

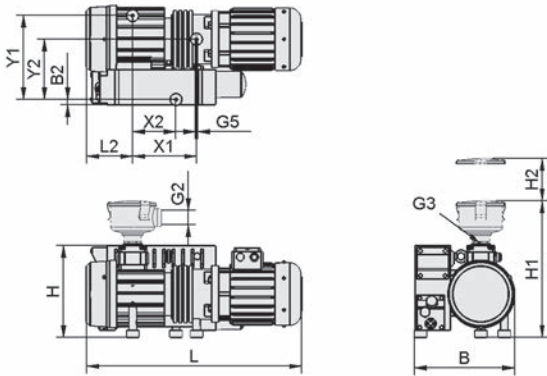

EVE-OG 10 - 40 AC3 (F)

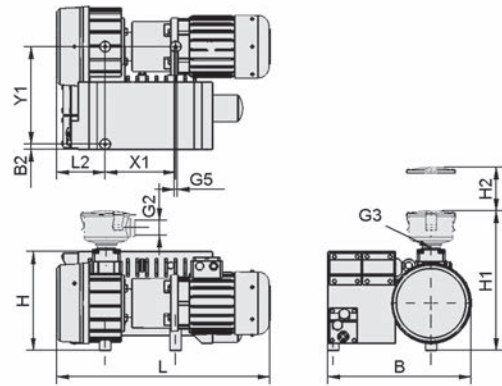

EVE-OG 63 - 100 AC3 (F)

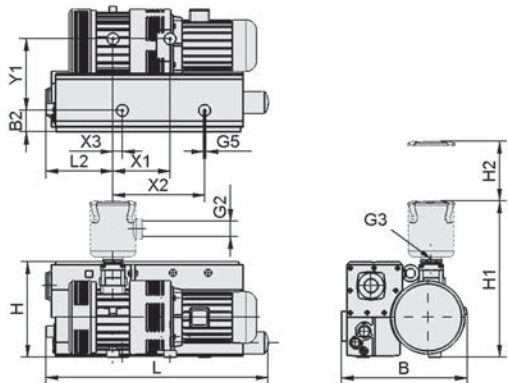

EVE-OG 165 - 255 AC3 (F)

- Schmalz – The Company
- Vacuum Suction Cups
- Special Grippers
- Gripping Systems
- Clamping Systems
- Mounting Elements
- Vacuum Generators
- Valve Technology
- Switches and Monitoring
- Filters and Connections
- Services
- Contact
- Glossary
- Index of Products



# Oil-Lubricated Vacuum Pumps EVE-OG

Suction rate from 10 m<sup>3</sup>/h to 255 m<sup>3</sup>/h



## Design Data Oil-Lubricated Vacuum Pumps EVE-OG

Type	B [mm]	B2 [mm]	G2	G3	G5	H [mm]	H1 [mm]	H2 [mm]	L [mm]	L2 [mm]	X1 [mm]	X2 [mm]	X3 [mm]	Y1 [mm]	Y2 [mm]
EVE-OG 10 AC3	212	26	-	G3/4"-F	M8-F	173	-	-	422	63	176	-	-	111	-
EVE-OG 10 AC3 F	212	26	G3/4"-F	G3/4"-F	M8-F	173	320	70	422	63	176	-	-	111	-
EVE-OG 16 AC3	212	26	-	G3/4"-F	M8-F	234	-	-	422	63	176	-	-	111	-
EVE-OG 16 AC3 F	212	26	G3/4"-F	G3/4"-F	M8-F	234	320	70	422	63	176	-	-	111	-
EVE-OG 25 AC3	284	17	-	G1-1/4"-F	M8-F	260	-	-	568	131	159	120	-	238	171
EVE-OG 25 AC3 F	284	17	G3/4"-F	G1-1/4"-F	M8-F	260	380	75	568	131	159	120	-	238	171
EVE-OG 40 AC3	284	15	-	G1-1/4"-F	M8-F	260	-	-	625	130	179	123	-	238	171
EVE-OG 40 AC3 F	284	15	G1-1/4"-F	G1-1/4"-F	M8-F	260	390	75	625	130	179	123	-	238	171
EVE-OG 63 AC3	406	15	-	G1-1/4"-F	M8-F	280	-	-	614	137	199	-	-	277	-
EVE-OG 63 AC3 F	406	15	G1-1/4"-F	G1-1/4"-F	M8-F	280	417	75	614	137	199	-	-	277	-
EVE-OG 100 AC3	406	15	-	G1-1/4"-F	M8-F	280	-	-	696	170	226	-	-	277	-
EVE-OG 100 AC3 F	406	15	G1-1/4"-F	G1-1/4"-F	M8-F	280	417	75	696	170	226	-	-	277	-
EVE-OG 165 AC3	554	92	-	G2-F	M10-F	418	-	-	921	285	243	390	40	305	-
EVE-OG 165 AC3 F	554	92	G2-1/2-F	G2-F	M10-F	418	680	240	921	285	243	390	40	305	-
EVE-OG 255 AC3	583	47	-	G2-F	M10-F	418	-	-	1,056	300	303	390	-	350	-
EVE-OG 255 AC3 F	583	47	G2-1/2-F	G2-F	M10-F	418	680	240	1,056	300	303	390	-	350	-



- Schmalz – The Company
- Vacuum Suction Cups
- Special Grippers
- Gripping Systems
- Clamping Systems
- Mounting Elements
- Vacuum Generators
- Valve Technology
- Switches and Monitoring
- Filters and Connections
- Services
- Contact
- Glossary
- Index of Products

# Vacuum Reservoirs VOL

Reservoir volume from 5 l to 200 l



Vacuum Reservoirs VOL

## Design

- Vacuum reservoir consisting of a steel tank with safety non-return valve, manometer and dust filter
- Coating RAL 7035

## Suitability for Industry Specific Applications

### Applications

- Vacuum reservoir for use as a safety backup in the case of sudden power failures
- Use where increased requirements for safety and reliability exist
- Suitable for use as a buffer for handling peak demands

## Our Highlights...

- Vacuum reservoir for use as a safety device
- Integrated non-return valve
- Large buffer volume

## Your Benefits...

- Prevents release of workpieces in the case of a sudden power failure
- Prevents the vacuum from escaping through the vacuum generator
- No need to dimension the vacuum generator to handle short-term peak demands



# Vacuum Centres VZ



Suction rate from 4 m<sup>3</sup>/h to 165 m<sup>3</sup>/h



## Suitability for Industry Specific Applications

### Applications

- Vacuum centre for use wherever there is a demand for high performance, safety and reliability

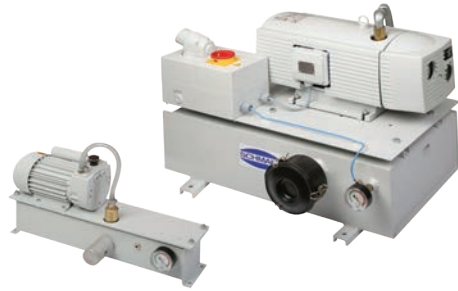

Vacuum Centres VZ

### Design

- Vacuum centre, consisting of vacuum pump, vacuum reservoir, safety non-return valve, filter and manometer
- Motor protection switch and vacuum regulated motor switch (adjustable) available as options
- Coating RAL 7035

### Our Highlights...

- Complete solution with pump, reservoir, manometer, filter and optional regulation
- Integrated dry-running or oil-lubricated vacuum pump
- Integrated vacuum reservoir
- Internal electrical regulation (automatic energy saving function, optional)

### Your Benefits...

- Universal use in vacuum clamping and handling applications
- Vibration free operation; continuous output with little pulsation
- Optimum protection against short-term leaks and power failures
- Economical use in continuous operation due to automatic pump switching and automatic regulation

- Schmalz – The Company
- Vacuum Suction Cups
- Special Grippers
- Gripping Systems
- Clamping Systems
- Mounting Elements
- Vacuum Generators
- Valve Technology
- Switches and Monitoring
- Filters and Connections
- Services
- Contact
- Glossary
- Index of Products



# Vacuum Blowers SGBL-DG

Suction rate from 78 m<sup>3</sup>/h to 540 m<sup>3</sup>/h



## Suitability for Industry Specific Applications

### Applications

- Vacuum blower for handling of cardboard boxes, foam materials, insulating materials, recycling materials and other extremely porous materials
- Enormous suction capacity easily compensates for any leaks

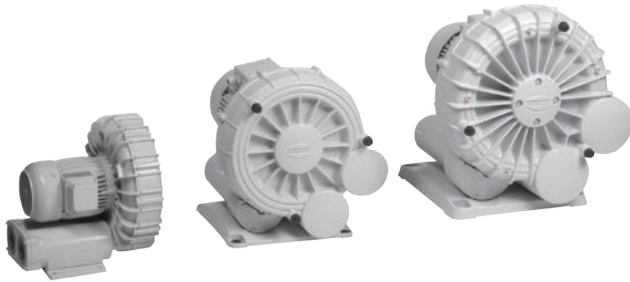

Vacuum Blowers SGBL-DG

### Design

- Vacuum blower in the form of a directly driven side channel compressor, housing and impeller made of high precision pressure cast aluminum
- Pressure relief valve included
- Motor protection switch and reversing valve with neutral position available as options

### Our Highlights...

- Blower with a very high suction capacity
- Housing and impeller made of high precision pressure cast aluminum
- Wide range of models with different ratings

### Your Benefits...

- Reliable handling of porous materials
- Vibration free operation and high suction capacity
- Optimization to match customer requirements

## Designation Code Vacuum Blowers SGBL-DG

<b>SGBL</b>	-	<b>DG</b>	-	<b>310</b>	-	<b>270</b>	-	<b>3</b>	-	<b>DBV</b>
1		2		3		4		5		6

#### 1 - Abbreviated designation

Code	Version
SGBL	SGBL

#### 2 - Blower Type

Code	Type
DG	Directly driven

#### 3 - Performance class

Code	Suction rate in m <sup>3</sup> /h
80...540	80 to 540

#### 4 - Maximum vacuum

Code	Vacuum in mbar
110...465	110 to 465

#### 5 - Rated power

Code	Power in kW
0.25...7.5	0.25 to 7.5

#### 6 - Product addition

Code	Type
DBV	Pressure-limiter valve

Vacuum blower SGBL-DG is delivered as a ready-to-connect product.

Available accessories: silencer box, dust filter



Schmalz – The Company  
Vacuum Suction Cups  
Special Grippers  
Gripping Systems  
Clamping Systems  
Mounting Elements  
Vacuum Generators  
Valve Technology  
Switches and Monitoring  
Filters and Connections  
Services  
Contact  
Glossary  
Index of Products

# Vacuum Blowers SGBL-DG

Suction rate from 78 m<sup>3</sup>/h to 540 m<sup>3</sup>/h



## Ordering Data Vacuum Blowers SGBL-DG

Type	Part no.
SGBL-DG-80-110-0.25	10.04.01.00008
SGBL-DG-145-120-0.7-DBV	10.04.01.00009
SGBL-DG-155-400-3	10.04.02.00067
SGBL-DG-165-180-0.95	10.04.01.00001
SGBL-DG-220-465-4	10.04.02.00068
SGBL-DG-310-270-3-DBV	10.04.01.00011
SGBL-DG-310-360-4	10.04.02.00002
SGBL-DG-310-420-5.5	10.04.02.00086
SGBL-DG-410-225-4	10.04.02.00077
SGBL-DG-490-370-7.5	10.04.02.00003
SGBL-DG-540-200-4	10.04.01.00012



## Ordering Data Accessories Vacuum Blowers SGBL-DG

Type	Accessories	Part no.
SGBL-DG-155-400-3	Silencer box SBB-661x586x565-ST/ABS-VZ	10.04.04.00108
SGBL-DG-220-465-4	Silencer box SBB-661x586x600-ST/ABS-VZ	10.04.04.00109
SGBL-DG-310-270-3-DBV	Silencer box SBB-SBL-806x690x610-ST	10.04.04.00031
SGBL-DG-310-360-4	Silencer box SBB-SBL-806x690x610-ST	10.04.04.00031
SGBL-DG-310-420-5.5	Silencer box SBB-SBL-806x690x610-ST	10.04.04.00031
SGBL-DG-410-225-4	Silencer box SBB-SGBL-661x586x600-ST/ABS-VZ	10.04.04.00127
SGBL-DG-490-370-7.5	Silencer box SBB-SBL-840x740x743-ST-VZ-LUE	10.04.04.00056
SGBL-DG-540-200-4	Silencer box SBB-ST	10.04.04.00077

Type	Accessories	Part no.
SGBL-DG-80-110-0.25	Dust filter STF G1-1/4-IG N	10.07.01.00008
SGBL-DG-145-120-0.7-DBV	Dust filter STF 60 P 4.5 SSD	10.07.01.00259
SGBL-DG-155-400-3	Dust filter STF 60 P 4.5 SSD	10.07.01.00259
SGBL-DG-165-180-0.95	Dust filter STF 60 P 4.5 SSD	10.07.01.00259
SGBL-DG-220-465-4	Dust filter STF 60 P 4.5 SSD	10.07.01.00259
SGBL-DG-310-270-3-DBV	Dust filter STF 60 P 6.0 SSD	10.07.01.00260
SGBL-DG-310-360-4	Dust filter STF 60 P 6.0 SSD	10.07.01.00260
SGBL-DG-310-420-5.5	Dust filter STF 60 P 6.0 SSD	10.07.01.00260
SGBL-DG-410-225-4	Dust filter STF 60 P 6.0 SSD	10.07.01.00260
SGBL-DG-490-370-7.5	Dust filter STF 75 P 8.0 SSD	10.07.01.00263
SGBL-DG-540-200-4	Dust filter STF 75 P 8.0 SSD	10.07.01.00263



# Vacuum Blowers SGBL-DG

Suction rate from 78 m<sup>3</sup>/h to 540 m<sup>3</sup>/h



## Technical Data Vacuum Blowers SGBL-DG

Type	Suction rate (50 Hz) [m <sup>3</sup> /h]	Suction capacity (60 Hz) [m <sup>3</sup> /h]	Max. vacuum [mbar]	Voltage 50 Hz	Voltage 60 Hz
SGBL-DG-80-110-0.25	78	98	-110	200-240V or 345-415V V	220-275V or 380-480V V
SGBL-DG-145-120-0.7-DBV	145	177	-120	200-240V or 345-415V V	220-275V or 380-480V V
SGBL-DG-155-400-3	155	187	-400	190-255V or 330-440V V	190-290V or 330-500V V
SGBL-DG-165-180-0.95	165	195	-180	230V or 400V V	277V or 480V V
SGBL-DG-220-465-4	220	262	-465	190-255V or 330-440V V	190-290V or 330-500V V
SGBL-DG-310-270-3-DBV	310	380	-270	200-240V or 345-415V V	220-275V or 380-480V V
SGBL-DG-310-360-4	310	380	-360	380-420V or 660-725V V	440-480V V
SGBL-DG-310-420-5.5	310	420	-420	345-415V or 600-720V V	380-480V or 660-720V V
SGBL-DG-410-225-4	410	502	-225	190-255V or 330-440V V	190-290V or 330-500V V
SGBL-DG-490-370-7.5	490	610	-370	345-415V or 600-720V V	380-480V or 660-720V V
SGBL-DG-540-200-4	540	630	-200	345-415V or 690V V	380-480V V

Type	Rated power 50 Hz [kW]	Rated power 60 Hz [kW]	Protection type IP	Weight [kg]	Sound level at 50 Hz [dB(A)]*
SGBL-DG-80-110-0.25	0.25	0.29	55	11	53
SGBL-DG-145-120-0.7-DBV	0.70	0.83	55	15	63
SGBL-DG-155-400-3	3.00	3.60	55	47	76
SGBL-DG-165-180-0.95	0.95	1.60	54	30	72
SGBL-DG-220-465-4	4.00	4.80	55	68	74
SGBL-DG-310-270-3-DBV	3.00	3.45	55	38	70
SGBL-DG-310-360-4	4.00	4.80	55	55	75
SGBL-DG-310-420-5.5	5.50	6.30	55	70	75
SGBL-DG-410-225-4	4.00	4.60	55	71	74
SGBL-DG-490-370-7.5	7.50	8.60	55	188	75
SGBL-DG-540-200-4	4.00	4.60	55	112	71

\*Reduction with silencer box down to approximately 65 %

# Vacuum Blowers SGBL-DG

Suction rate from 78 m<sup>3</sup>/h to 540 m<sup>3</sup>/h

## Performance Data Vacuum Blowers SGBL-DG

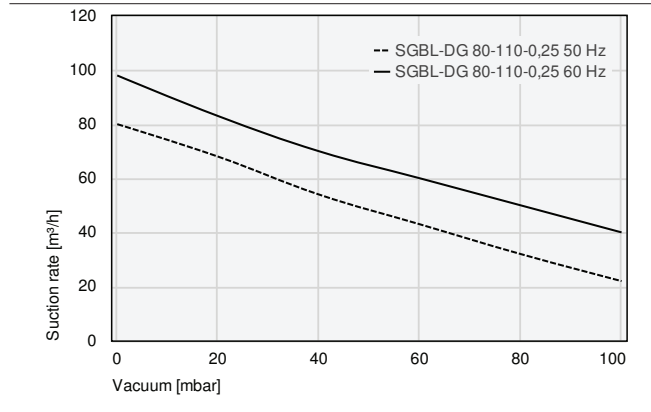

Suction capacity at various degrees of evacuation

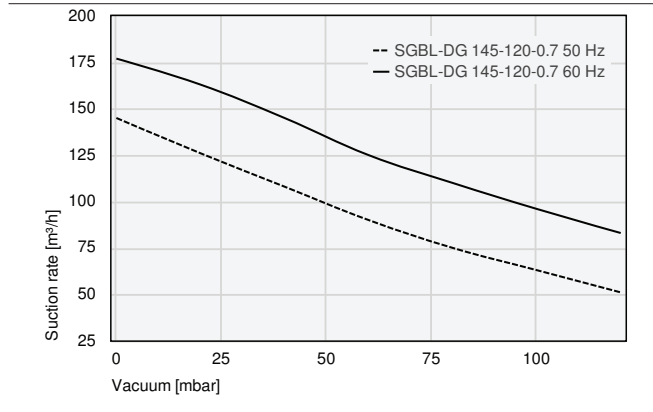

Suction capacity at various degrees of evacuation

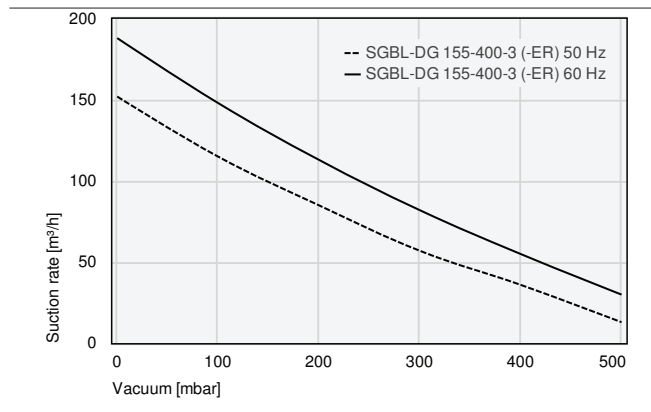

Suction capacity at various degrees of evacuation

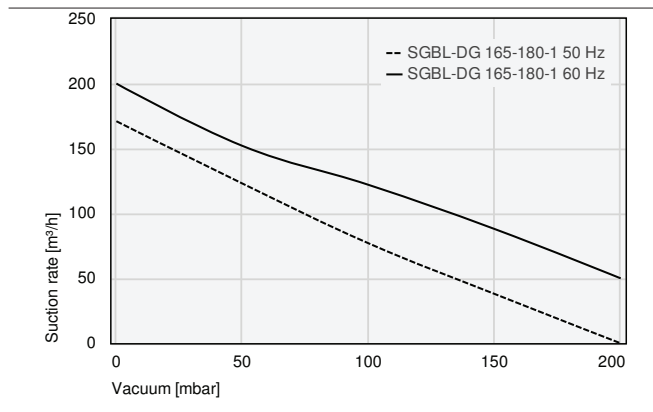

Suction capacity at various degrees of evacuation

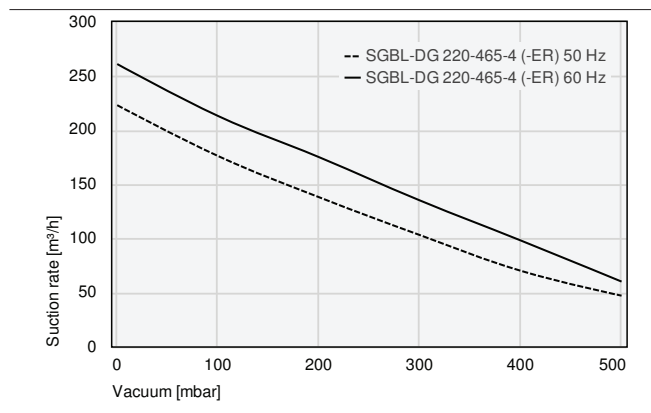

Suction capacity at various degrees of evacuation

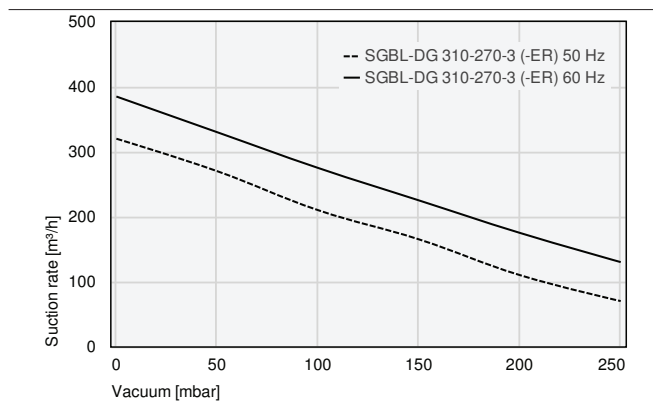

Suction capacity at various degrees of evacuation

- Schmalz – The Company
- Vacuum Suction Cups
- Special Grippers
- Gripping Systems
- Clamping Systems
- Mounting Elements
- Vacuum Generators
- Valve Technology
- Switches and Monitoring
- Filters and Connections
- Services
- Contact
- Glossary
- Index of Products

Suction rate from 78 m<sup>3</sup>/h to 540 m<sup>3</sup>/h



## Performance Data Vacuum Blowers SGBL-DG

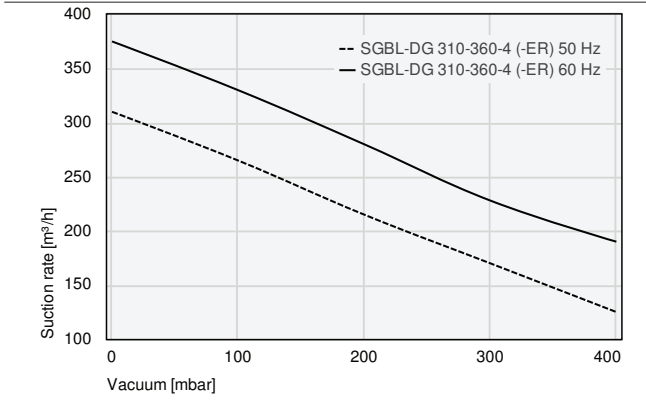

Suction capacity at various degrees of evacuation

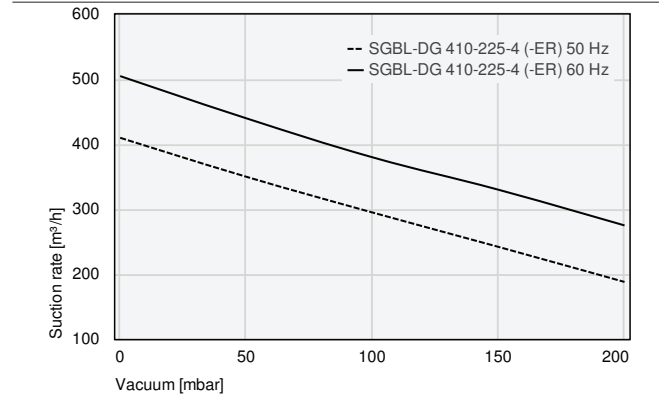

Suction capacity at various degrees of evacuation

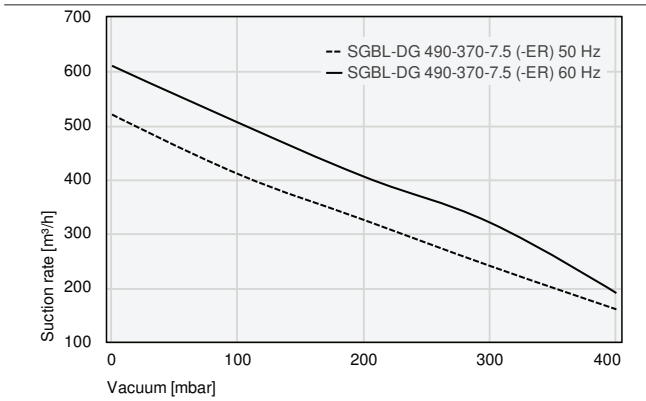

Suction capacity at various degrees of evacuation

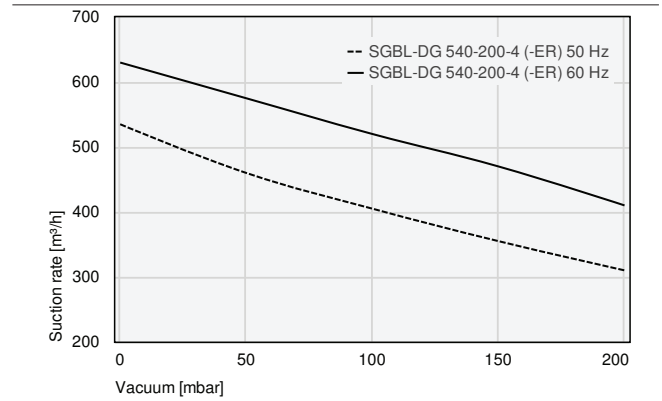

Suction capacity at various degrees of evacuation

- Schmalz – The Company
- Vacuum Suction Cups
- Special Grippers
- Gripping Systems
- Clamping Systems
- Mounting Elements
- Vacuum Generators
- Valve Technology
- Switches and Monitoring
- Filters and Connections
- Services
- Contact
- Glossary
- Index of Products

# Vacuum Blowers SGBL-DG

Suction rate from 78 m<sup>3</sup>/h to 540 m<sup>3</sup>/h

**Design Data Vacuum Blowers SGBL-DG**

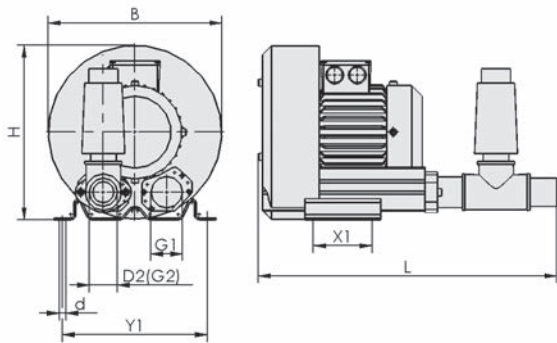

SGBL-DG 80-110-0.25, SGBL-DG 145-120-0.7, SGBL-DG 310-270-3, SGBL-DG 540-200-4

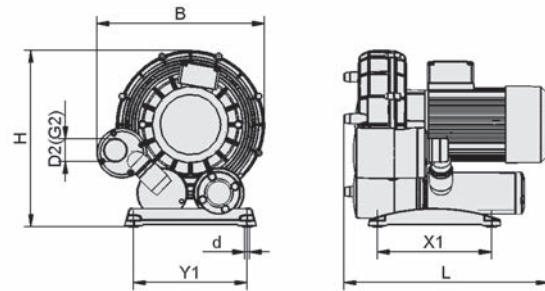

SGBL-DG 155-400-3, SGBL-DG 165-180-1, SGBL-DG 220-465-4, SGBL-DG 410-255-4

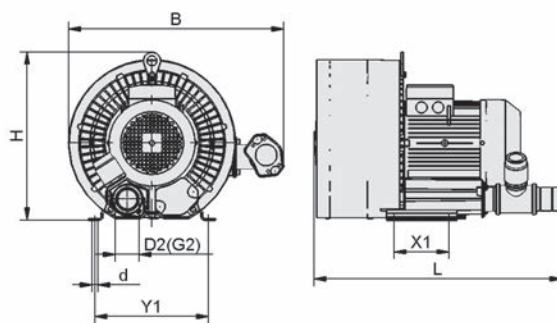

SGBL-DG 310-360-4, SGBL-DG 310-420-5.5

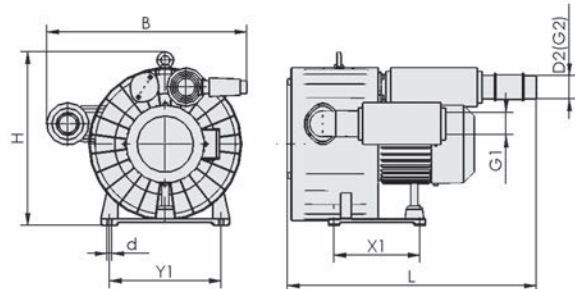

SGBL-DG 490-370-7.5

Type	B [mm]	d [mm]	d1 [mm]	D2 [mm]	G1	G2	H [mm]	L [mm]	X1 [mm]	Y1 [mm]
SGBL-DG-80-110-0.25	246	10	-	40	G1-1/2"-F	G1-1/4"-F	247	425	83	205
SGBL-DG-145-120-0.7-DBV	285	12	-	60	G1-1/2"-F	G2"-M	302	460	95	225
SGBL-DG-155-400-3	427	12	-	60	-	G2"-M	450	522	290	290
SGBL-DG-165-180-0.95	358	11	40	50	G2"-F	G1-1/2"-F	375	357	120	220
SGBL-DG-220-465-4	496	12	35	60	G2"-F	G2"-M	522	520	310	310
SGBL-DG-310-270-3-DBV	381	15	-	60	G2"-F	G2"-F	384	542	140	290
SGBL-DG-310-360-4	550	15	-	60	-	G2"-M	420	633	140	290
SGBL-DG-310-420-5.5	541	15	-	60	G2"-F	G2"-F	429	780	140	290
SGBL-DG-410-225-4	496	12	35	60	G2"-F	G2"-M	522	520	310	310
SGBL-DG-490-370-7.5	655	15	-	75	G2-1/2"-M	G2-1/2"-M	566	810	280	365
SGBL-DG-540-200-4	498	15	-	75	G2-1/2"-F	G2-1/2"-F	566	792	280	365

Schmalz - The Company  
Vacuum Suction Cups  
Special Grippers  
Gripping Systems  
Clamping Systems  
Mounting Elements  
Vacuum Generators  
Valve Technology  
Switches and Monitoring  
Filters and Connections  
Services  
Contact  
Glossary  
Index of Products

# Vacuum Blowers SB

Suction rate from 75 m<sup>3</sup>/h to 1,250 m<sup>3</sup>/h



Vacuum Blowers SB

## Design

- Vacuum blower with high precision, die-cast aluminum housing and impeller
- Preconfigured pressure limiting valve included
- Motor in top energy efficiency class (IE3)

## Suitability for Industry Specific Applications

### Applications

- Vacuum blower for handling cardboard, insulating material, recycled material and other porous materials
- Enormous suction rate compensates for leaks

## Our Highlights...

- Blower with extreme suction rate
- Die-cast aluminum housing and impeller
- Broad performance range

## Your Benefits...

- Reliable handling of porous materials
- Vibration free operation and high suction rate
- Optimized to meet customer requirements



## Designation Code Vacuum Blowers SB

<b>SB</b>	-	<b>210</b>	-	<b>370</b>	-	<b>3</b>	-	<b>IE3-Type1</b>
<b>1</b>		<b>2</b>		<b>3</b>		<b>4</b>		<b>5</b>

### 1 – Abbreviated designation

Code	Version
SB	SB

### 2 – Performance class

Code	Suction rate in m <sup>3</sup> /h
75...1250	75 to 1,250

### 3 – Max. vacuum

Code	Vacuum in mbar
105...410	-105 to -410

### 4 – Rated power

Code	Power in kW
0,37...13,2	0.37 to 13.20

### 5 – Motor type

Code	Type
IE1	IE1
IE3-Type1	IE3 Type 1
IE3-Type2	IE3 Type 2
IE3-Type3	IE3 Type 3

The vacuum blower SB is delivered as a ready-to-connect product.

Available accessories: silencer box, dust filter

Suction rate from 75 m<sup>3</sup>/h to 1,250 m<sup>3</sup>/h

## Ordering Data Vacuum Blowers SB

Type	Part no.
SB 75 105 0.37 IE1	10.04.01.00065
SB 130 125 0.75 IE3-TYP1	10.04.01.00066
SB 130 125 0.75 IE3-TYP3	10.04.01.00067
SB 160 115 0.9 IE3-TYP2	10.04.01.00068
SB 90 330 1.5 IE3-TYP1	10.04.01.00087
SB 90 330 1.5 IE3-TYP3	10.04.01.00088
SB 110 350 1.8 IE3-TYP2	10.04.01.00089
SB 180 215 1.5 IE3-TYP1	10.04.01.00069
SB 180 215 1.5 IE3-TYP3	10.04.01.00070
SB 230 230 1.8 IE3-TYP2	10.04.01.00071
SB 325 265 3 IE3-TYP1	10.04.01.00072
SB 325 265 3 IE3-TYP3	10.04.01.00073
SB 390 245 3.6 IE3-TYP2	10.04.01.00074
SB 195 440 3 IE3-TYP1	10.04.01.00090
SB 195 440 3 IE3-TYP3	10.04.01.00091
SB 235 400 3.6 IE3-TYP2	10.04.01.00092
SB 260 410 4 IE3-TYP1	10.04.01.00093
SB 260 410 4 IE3-TYP3	10.04.01.00094
SB 305 400 4.8 IE3-TYP2	10.04.01.00095
SB 390 315 4 IE3-TYP1	10.04.01.00075
SB 390 315 4 IE3-TYP3	10.04.01.00076
SB 470 290 4.8 IE3-TYP2	10.04.01.00077
SB 510 200 4 IE3-TYP1	10.04.01.00078
SB 510 200 4 IE3-TYP3	10.04.01.00079
SB 610 175 4.8 IE3-TYP2	10.04.01.00080
SB 370 390 5.5 IE3-TYP1	10.04.01.00096
SB 370 390 5.5 IE3-TYP3	10.04.01.00097
SB 440 360 6.6 IE3-TYP2	10.04.01.00098
SB 750 300 7.5 IE3-TYP1	10.04.01.00081
SB 750 300 7.5 IE3-TYP3	10.04.01.00082
SB 900 280 9 IE3-TYP2	10.04.01.00083
SB 520 390 11 IE3-TYP1	10.04.01.00099
SB 520 390 11 IE3-TYP3	10.04.01.00100
SB 610 390 13.2 IE3-TYP2	10.04.01.00101
SB 1050 290 11 IE3-TYP1	10.04.01.00084
SB 1050 290 11 IE3-TYP3	10.04.01.00085
SB 1250 270 13.2 IE3-TYP2	10.04.01.00086



## Ordering Data Accessories Vacuum Blowers SB

Type	Dust filter	Silencer box
SB 75 105 0.37 IE1	10.07.01.00008	-
SB 130 125 0.75 IE3-TYP1	10.07.01.00398	-
SB 130 125 0.75 IE3-TYP3	10.07.01.00398	-
SB 160 115 0.9 IE3-TYP2	10.07.01.00398	-
SB 90 330 1.5 IE3-TYP1	10.07.01.00259	10.04.04.00234
SB 90 330 1.5 IE3-TYP3	10.07.01.00259	10.04.04.00234
SB 110 350 1.8 IE3-TYP2	10.07.01.00259	10.04.04.00234
SB 180 215 1.5 IE3-TYP1	10.07.01.00259	10.04.04.00234
SB 180 215 1.5 IE3-TYP3	10.07.01.00259	10.04.04.00234
SB 230 230 1.8 IE3-TYP2	10.07.01.00259	10.04.04.00234

# Vacuum Blowers SB

Suction rate from 75 m<sup>3</sup>/h to 1,250 m<sup>3</sup>/h



## Ordering Data Accessories Vacuum Blowers SB

Type	Dust filter	Silencer box
SB 325 265 3 IE3-TYP1	10.07.01.00384	10.04.04.00235
SB 325 265 3 IE3-TYP3	10.07.01.00384	10.04.04.00235
SB 390 245 3.6 IE3-TYP2	10.07.01.00384	10.04.04.00235
SB 195 440 3 IE3-TYP1	10.07.01.00259	10.04.04.00236
SB 195 440 3 IE3-TYP3	10.07.01.00259	10.04.04.00236
SB 235 400 3.6 IE3-TYP2	10.07.01.00259	10.04.04.00236
SB 260 410 4 IE3-TYP1	10.07.01.00260	10.04.04.00237
SB 260 410 4 IE3-TYP3	10.07.01.00260	10.04.04.00237
SB 305 400 4.8 IE3-TYP2	10.07.01.00260	10.04.04.00237
SB 390 315 4 IE3-TYP1	10.07.01.00263	10.04.04.00236
SB 390 315 4 IE3-TYP3	10.07.01.00263	10.04.04.00236
SB 470 290 4.8 IE3-TYP2	10.07.01.00399	10.04.04.00236
SB 510 200 4 IE3-TYP1	10.07.01.00399	10.04.04.00237
SB 510 200 4 IE3-TYP3	10.07.01.00399	10.04.04.00237
SB 610 175 4.8 IE3-TYP2	10.07.01.00399	10.04.04.00237
SB 370 390 5.5 IE3-TYP1	10.07.01.00263	10.04.04.00238
SB 370 390 5.5 IE3-TYP3	10.07.01.00263	10.04.04.00238
SB 440 360 6.6 IE3-TYP2	10.07.01.00263	10.04.04.00238
SB 750 300 7.5 IE3-TYP1	10.07.01.00400	10.04.04.00239
SB 750 300 7.5 IE3-TYP3	10.07.01.00400	10.04.04.00239
SB 900 280 9 IE3-TYP2	10.07.01.00400	10.04.04.00239
SB 520 390 11 IE3-TYP1	10.07.01.00406	10.04.04.00239
SB 520 390 11 IE3-TYP3	10.07.01.00406	10.04.04.00239
SB 610 390 13.2 IE3-TYP2	10.07.01.00406	10.04.04.00239
SB 1050 290 11 IE3-TYP1	10.07.01.00401	10.04.04.00239
SB 1050 290 11 IE3-TYP3	10.07.01.00401	10.04.04.00239
SB 1250 270 13.2 IE3-TYP2	10.07.01.00401	10.04.04.00239



## Technical Data Vacuum Blowers SB

Type	Motortype 1 ≤ 4,8kW	Motortype 1 > 4,8kW	Motortype 2	Motortype 3
50Hz with IE3	230V / Y400V	400V	-	200V / Y350V
60Hz with IE3	265V / Y460V	460V	YY230V / Y460V	220V / Y380-400V
60Hz without IE3	230V / Y400V	400V	YY208V	200V / Y350V



## Technical Data Vacuum Blowers SB

Type	Suction rate (50 Hz) [m <sup>3</sup> /h]	Suction capacity (60 Hz) [m <sup>3</sup> /h]	Vacuum (50 Hz) [mbar]	Vacuum (60 Hz) [mbar]	Protection type IP
SB 75 105 0.37 IE1	75	91	105	80	55
SB 130 125 0.75 IE3-TYP3	130	160	125	115	55
SB 160 115 0.9 IE3-TYP2	-	160	-	115	55
SB 90 330 1.5 IE3-TYP1	90	110	330	350	55
SB 110 350 1.8 IE3-TYP2	-	110	-	350	55
SB 180 215 1.5 IE3-TYP1	180	230	215	230	55



Suction rate from 75 m<sup>3</sup>/h to 1,250 m<sup>3</sup>/h



## Technical Data Vacuum Blowers SB

Type	Suction rate (50 Hz) [m <sup>3</sup> /h]	Suction capacity (60 Hz) [m <sup>3</sup> /h]	Vacuum (50 Hz) [mbar]	Vacuum (60 Hz) [mbar]	Protection type IP
SB 230 230 1.8 IE3-TYP2	-	230	-	230	55
SB 325 265 3 IE3-TYP1	325	390	265	245	55
SB 390 245 3.6 IE3-TYP2	-	390	-	245	55
SB 195 440 3 IE3-TYP3	195	235	440	400	55
SB 235 400 3.6 IE3-TYP2	-	235	-	400	55
SB 260 410 4 IE3-TYP3	260	305	410	400	55
SB 305 400 4.8 IE3-TYP2	-	305	-	400	55
SB 390 315 4 IE3-TYP3	390	470	315	290	55
SB 470 290 4.8 IE3-TYP2	-	470	-	290	55
SB 510 200 4 IE3-TYP1	510	610	200	175	55
SB 610 175 4.8 IE3-TYP2	-	610	-	175	55
SB 370 390 5.5 IE3-TYP3	370	440	390	360	55
SB 440 360 6.6 IE3-TYP2	-	440	-	360	55
SB 750 300 7.5 IE3-TYP1	750	900	300	280	55
SB 900 280 9 IE3-TYP2	-	900	-	280	55
SB 520 390 11 IE3-TYP1	520	610	390	390	55
SB 610 390 13.2 IE3-TYP2	-	610	-	390	55
SB 1050 290 11 IE3-TYP1	1,050	1,250	290	270	55
SB 1250 270 13.2 IE3-TYP2	-	1,250	-	270	55

Type	Rated power 50 Hz [kW]	Rated power 60 Hz [kW]	Sound level at 50 Hz [dB(A)]	Sound level at 60 Hz [dB(A)]	Weight [kg]
SB 75 105 0.37 IE1	0.4	0.44	62.0	63	13.0
SB 130 125 0.75 IE3-TYP1	0.8	0.90	56.8	62	21.7
SB 160 115 0.9 IE3-TYP2	-	0.90	-	62	21.7
SB 90 330 1.5 IE3-TYP3	1.5	1.80	63.7	69	28.5
SB 110 350 1.8 IE3-TYP2	-	1.80	-	69	28.5
SB 180 215 1.5 IE3-TYP1	1.5	1.80	63.9	70	28.5
SB 230 230 1.8 IE3-TYP2	-	1.80	-	70	28.5
SB 325 265 3 IE3-TYP1	3.0	3.60	70.1	71	42.5
SB 390 315 4 IE3-TYP1	4.0	4.80	72.5	75	53.0
SB 195 440 3 IE3-TYP1	3.0	3.60	71.1	73	49.0
SB 235 400 3.6 IE3-TYP2	-	3.60	-	73	49.0
SB 260 410 4 IE3-TYP1	4.0	4.80	68.9	72	62.5
SB 305 400 4.8 IE3-TYP2	-	4.80	-	72	62.5
SB 390 315 4 IE3-TYP3	4.0	4.80	72.5	75	53.0
SB 470 290 4.8 IE3-TYP2	-	4.80	-	75	53.0
SB 510 200 4 IE3-TYP1	4.0	4.80	75.5	77	61.5
SB 610 175 4.8 IE3-TYP2	-	4.80	-	77	61.5
SB 370 390 5.5 IE3-TYP3	5.5	6.60	70.0	74	89.0
SB 440 360 6.6 IE3-TYP2	-	6.60	-	74	89.0
SB 750 300 7.5 IE3-TYP1	7.5	9.00	72.0	73	112.0
SB 900 280 9 IE3-TYP2	-	9.00	-	73	112.0
SB 520 390 11 IE3-TYP1	11.0	13.20	74.0	78	125.0
SB 610 390 13.2 IE3-TYP2	-	13.20	-	78	125.0
SB 1050 290 11 IE3-TYP1	11.0	13.20	75.0	79	125.0
SB 1250 270 13.2 IE3-TYP2	-	13.20	-	79	125.0



Schmalz – The Company  
Vacuum Suction Cups  
Special Grippers  
Gripping Systems  
Clamping Systems  
Mounting Elements  
Vacuum Generators  
Valve Technology  
Switches and Monitoring  
Filters and Connections  
Services  
Contact  
Glossary  
Index of Products



Suction rate from 75 m<sup>3</sup>/h to 1,250 m<sup>3</sup>/h



## Performance Data Vacuum Blowers SB

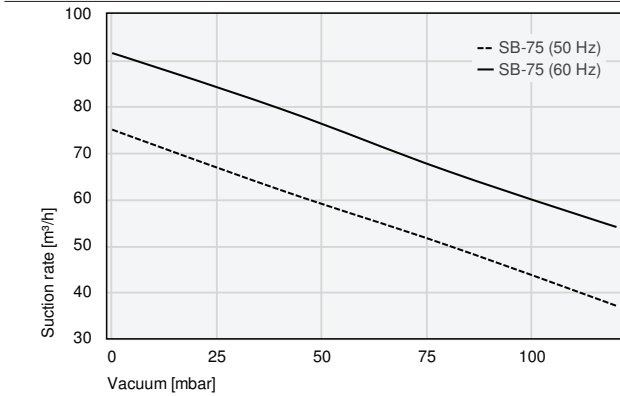

Suction capacity at various degrees of evacuation

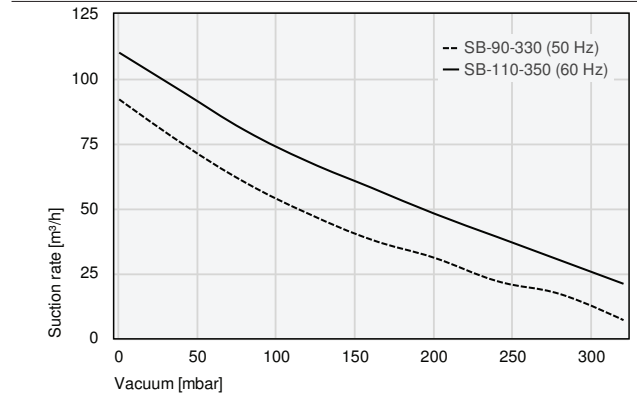

Suction capacity at various degrees of evacuation

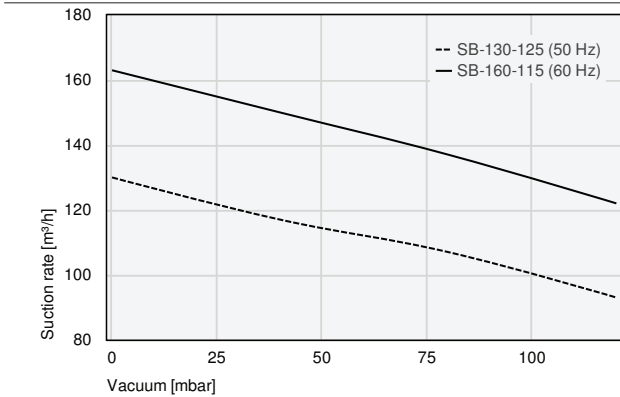

Suction capacity at various degrees of evacuation

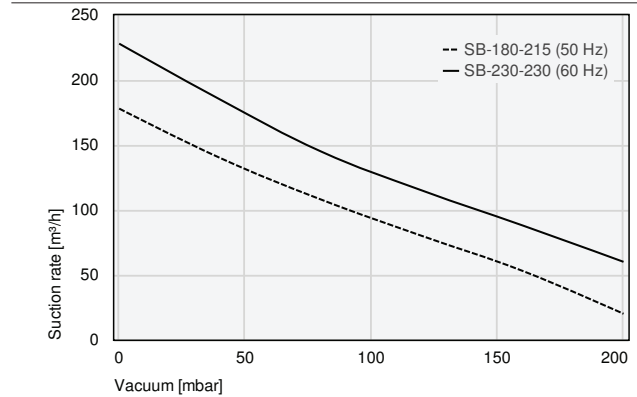

Suction capacity at various degrees of evacuation

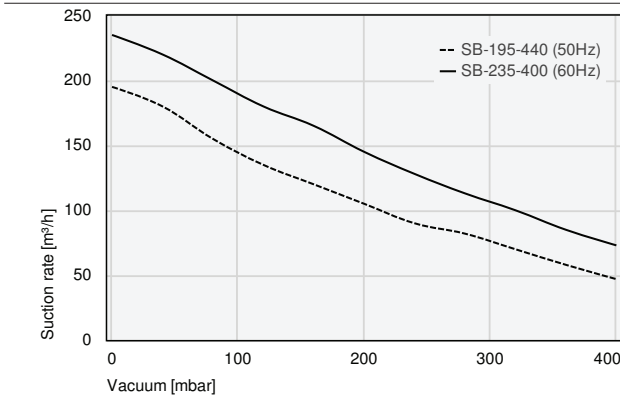

Suction capacity at various degrees of evacuation

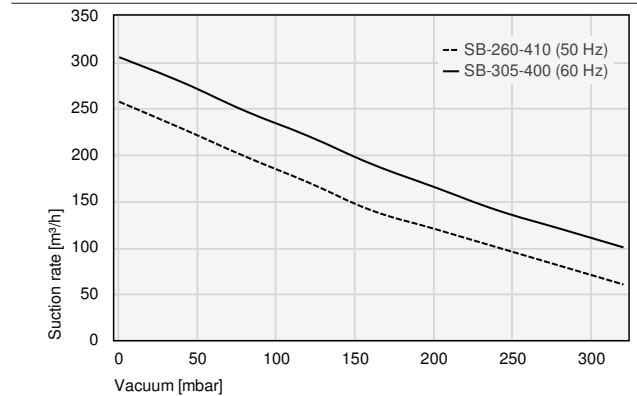

Suction capacity at various degrees of evacuation

- Schmalz – The Company
- Vacuum Suction Cups
- Special Grippers
- Gripping Systems
- Clamping Systems
- Mounting Elements
- Vacuum Generators
- Valve Technology
- Switches and Monitoring
- Filters and Connections
- Services
- Contact
- Glossary
- Index of Products



# Vacuum Blowers SB

Suction rate from 75 m<sup>3</sup>/h to 1,250 m<sup>3</sup>/h

## Performance Data Vacuum Blowers SB

- Schmalz – The Company
- Vacuum Suction Cups
- Special Grippers
- Gripping Systems
- Clamping Systems
- Mounting Elements
- Vacuum Generators
- Valve Technology
- Switches and Monitoring
- Filters and Connections
- Services
- Contact
- Glossary
- Index of Products

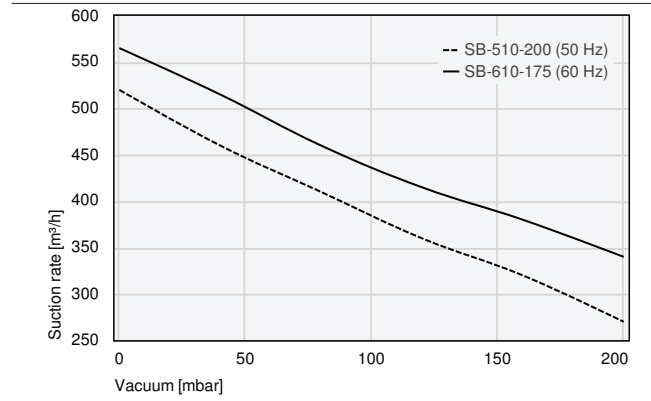
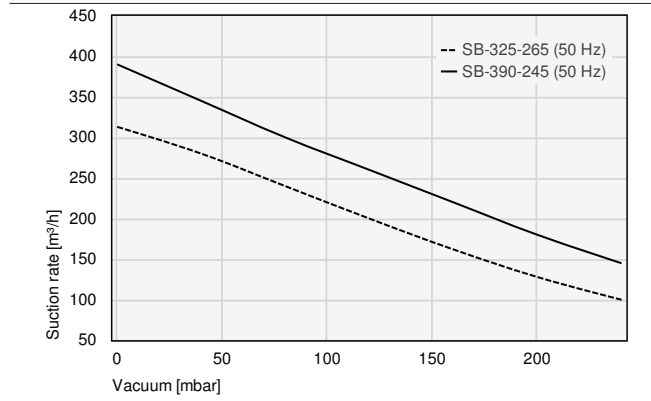

Suction capacity at various degrees of evacuation

Suction capacity at various degrees of evacuation

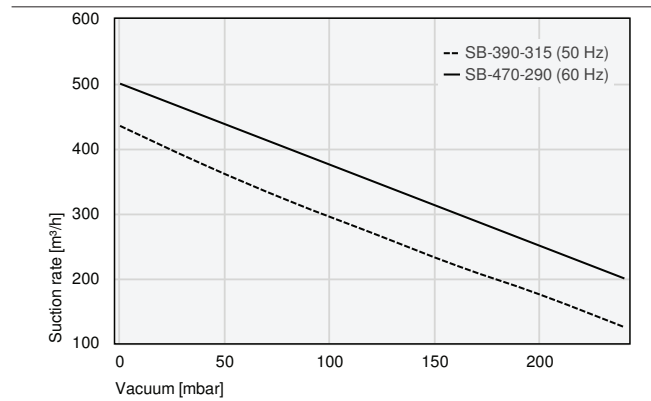
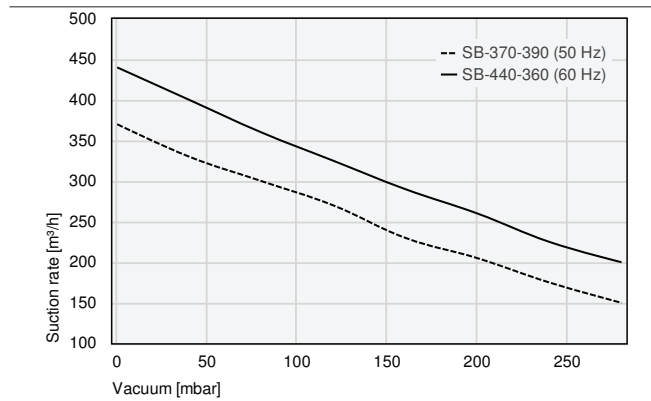

Suction capacity at various degrees of evacuation

Suction capacity at various degrees of evacuation

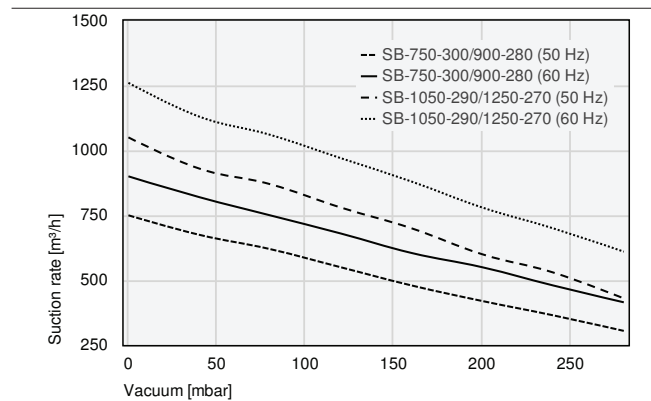
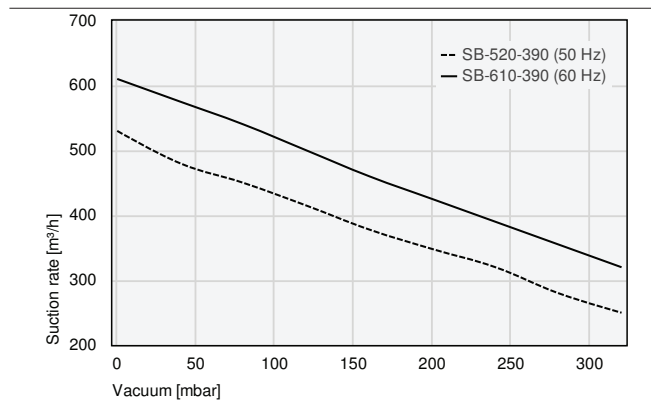

Suction capacity at various degrees of evacuation

Suction capacity at various degrees of evacuation

# Vacuum Blowers SB

Suction rate from 75 m<sup>3</sup>/h to 1,250 m<sup>3</sup>/h



## Design Data Vacuum Blowers SB

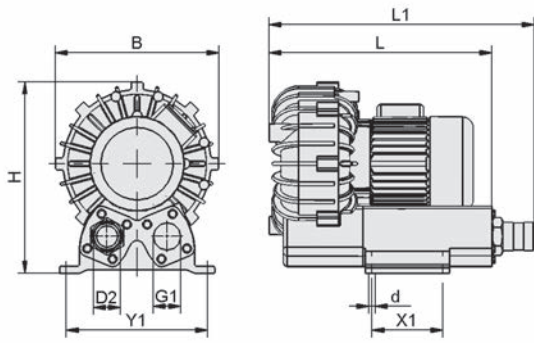

SB 0.37

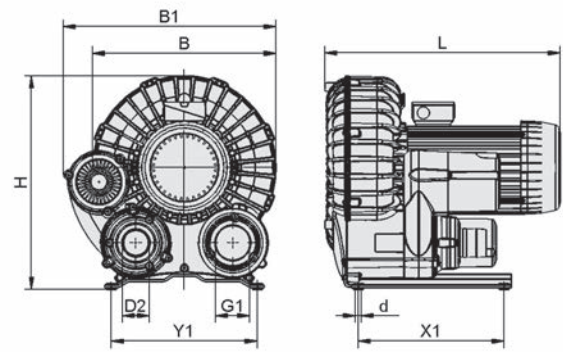

SB 0.75 - 4.8

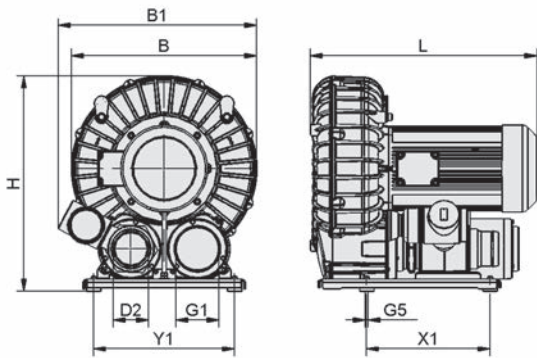

SB 5.5 - 13.2

Type	B [mm]	B1 [mm]	d [mm]	D2 [mm]	G1	G5	H [mm]	L [mm]	L1 [mm]	X1 [mm]	Y1 [mm]
SB 75 105 0.37 IE1	232	-	9.0	40	G1-1/4"-F	-	271	316.4	376.4	100	200
SB 130 125 0.75 IE3-TYP1	264	295.3	10.2	40	G1-1/2"-F	-	309	387.0	-	240	240
SB 160 115 0.9 IE3-TYP2	264	295.3	10.2	40	G1-1/2"-F	-	309	387.0	-	240	240
SB 90 330 1.5 IE3-TYP1	306	316.7	10.2	60	G1-1/2"-F	-	357	431.0	-	240	240
SB 110 350 1.8 IE3-TYP2	306	316.7	10.2	60	G1-1/2"-F	-	357	431.0	-	240	240
SB 180 215 1.5 IE3-TYP1	306	317.0	10.2	60	G1-1/2"-F	-	357	431.0	-	240	240
SB 230 230 1.8 IE3-TYP2	306	317.0	10.2	60	G1-1/2"-F	-	357	431.0	-	240	240
SB 325 265 3 IE3-TYP1	370	439.0	10.2	60	G2"-F	-	426	494.0	-	290	290
SB 390 245 3.6 IE3-TYP2	370	439.0	10.2	60	G2"-F	-	426	494.0	-	290	290
SB 195 440 3 IE3-TYP1	390	452.0	12.0	60	G2"-F	-	454	489.0	-	310	310

Schmalz – The Company  
Vacuum Suction Cups  
Special Grippers  
Gripping Systems  
Clamping Systems  
Mounting Elements  
Vacuum Generators  
Valve Technology  
Switches and Monitoring  
Filters and Connections  
Services  
Contact  
Glossary  
Index of Products



# Vacuum Blowers SB

Suction rate from 75 m<sup>3</sup>/h to 1,250 m<sup>3</sup>/h



## Design Data Vacuum Blowers SB

Type	B [mm]	B1 [mm]	d [mm]	D2 [mm]	G1	G5	H [mm]	L [mm]	L1 [mm]	X1 [mm]	Y1 [mm]
SB 235 400 3.6 IE3-TYP2	390	452.0	12.0	60	G2"-F	-	454	489.0	-	310	310
SB 260 410 4 IE3-TYP1	474	496.0	12.0	60	G2"-F	-	523	496.0	-	310	310
SB 305 400 4.8 IE3-TYP2	474	496.0	12.0	60	G2"-F	-	523	496.0	-	310	310
SB 390 315 4 IE3-TYP1	390	452.0	12.0	76	G2"-F	-	454	502.0	-	310	310
SB 470 290 4.8 IE3-TYP2	390	452.0	12.0	76	G2"-F	-	454	502.0	-	310	310
SB 510 200 4 IE3-TYP1	474	496.0	12.0	76	G2"-F	-	523	496.0	-	310	310
SB 610 175 4.8 IE3-TYP2	474	496.0	12.0	76	G2"-F	-	523	496.0	-	310	310
SB 370 390 5.5 IE3-TYP1	496	535.0	-	76	G4"-F	M8-F	596	563.0	-	350	400
SB 440 360 6.6 IE3-TYP2	496	535.0	-	76	G4"-F	M8-F	596	563.0	-	350	400
SB 750 300 7.5 IE3-TYP3	496	548.0	-	100	G4"-F	M8-F	596	614.0	-	350	400
SB 900 280 9 IE3-TYP2	496	548.0	-	100	G4"-F	M8-F	596	614.0	-	350	400
SB 520 390 11 IE3-TYP1	525	563.0	-	100	G4"-F	M8-F	611	643.0	-	350	400
SB 610 390 13.2 IE3-TYP2	525	563.0	-	100	G4"-F	M8-F	611	643.0	-	350	400
SB 1050 290 11 IE3-TYP1	525	563.0	-	100	G4"-F	M8-F	611	643.0	-	350	400
SB 1250 270 13.2 IE3-TYP2	525	563.0	-	100	G4"-F	M8-F	611	643.0	-	350	400

- Schmalz – The Company
- Vacuum Suction Cups
- Special Grippers
- Gripping Systems
- Clamping Systems
- Mounting Elements
- Vacuum Generators
- Valve Technology
- Switches and Monitoring
- Filters and Connections
- Services
- Contact
- Glossary
- Index of Products



# Vacuum Generator ECBPi

Suction rate up to 12 l/min



Vacuum Generator ECBPi

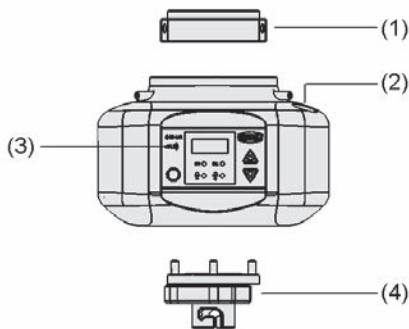

System Design Vacuum Generator ECBPi



Electric vacuum generator ECBPi when handling cardboard boxes

## Suitability for Industry Specific Applications

### Applications

- Intelligent electrical vacuum generator for handling airtight and slightly porous workpieces
- Integrated interface for controlling and monitoring the handling process
- For use in mobile robotics, fully automated small parts handling and stationary handling tasks

### Design

- Flange adapter plate (1) for mechanical connection to all common cobot models
- M12 8-pin plug connection or terminal block as digital interface (2) between the ECBPi and the robot
- NFC interface (3) for conveniently transferring data using a smartphone
- Flange for gripper connection (4)

### Our Highlights...

- IO-Link connection for transparent process data
- Condition monitoring to reduce errors and downtime
- NFC interface for data transmission
- Integrated function for automatically adapting the power to the handling process
- Targeted process monitoring, predictive maintenance
- Secures and improves the availability of the system
- Easy, direct access to the device and process data from a smartphone
- Easy parameterization on the device for improved energy efficiency in the process

# Vacuum Generator ECBPi

Suction rate up to 12 l/min



## Designation Code Vacuum Generator ECBPi

<b>ECBPi</b>	-	<b>24V-DC</b>	-	<b>M12-8</b>
<b>1</b>		<b>2</b>		<b>3</b>

### 1 – Abbreviated designation

Code	Version
ECBPi	Electrical CobotPump

### 2 – Voltage

Code	Operating voltage
24V-DC	24V-DC

### 3 – Electrical connection

Code	Type
M12-8	M12, 8-pin plug
TB-8	Terminal strip

The electrical vacuum generator ECBPi is delivered as a ready-to-connect product.

Available accessories: flange plate, connection cable, connection distributor



## Ordering Data Vacuum Generator ECBPi

Type	Part no.
ECBPi 12 24V-DC M12-8	10.03.01.00314
ECBPi 12 24V-DC TB-8	10.03.01.00364



## Ordering Data Accessories Vacuum Generator ECBPi

Type	Part no.
Flange plate robot UR, KUKA iiwa	FLAN-PL UR-KUK-1 10.03.01.00313
Flange plate robot YASKAWA Motoman HC10	FLAN-PL YAS-1 10.03.01.00357
Flange plate robot application RETHINK	FLAN-PL RET-1 10.03.01.00358
Flange plate robot RETHINK ClickSmartAdapter	FLAN-PL RET-2 10.03.01.00373
Flange plate robot universal	FLAN-PL ECBPi 10.03.01.00379
Flange plate robot FANUC	FLAN-PL FAN-1 10.03.01.00390
Connection cable, M12 8-pole, M8 8-pole, 0.28 m, PUR, straight	ASK B-M12-8 280 WB-M8-8 21.04.05.00350
Connection distributor 1x M12, 8 pol, 1x M8, 8 pol, 1x M8, 3 pol	ASV ECBPi WS-M8-3 WS-M8-8 21.04.05.00361
Connection distributor 1x M12, 8 pol, 1x M8, 8 pol, 1x M8, 4 pol	ASV ECBPi WS-M8-4 WS-M8-8 21.04.05.00362



## Technical Data Vacuum Generator ECBPi

Type	Suction rate (max.) [l/min]	Rated power [W]	Voltage	Rated current [A]	Operating temperature [°C]	Weight [g]
ECBPi 12 24V-DC M12-8	12	13	24V - DC V	0.6	5 ... 45	775
ECBPi 12 24V-DC TB-8	12	13	24V - DC V	0.6	5 ... 45	775



# Vacuum Generator ECBPi

Suction rate up to 12 l/min



## Design Data Vacuum Generator ECBPi

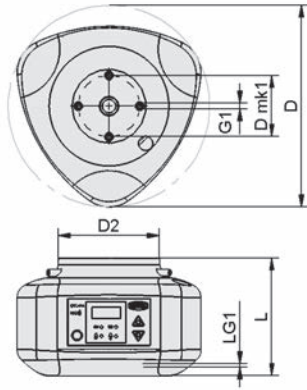

ECBPi

Type	D [mm]	D mk1 [mm]	D2 [mm]	G1	L [mm]	LG1 [mm]
ECBPi 12 24V-DC M12-8	151.5	46	76	M4-F	88.6	6
ECBPi 12 24V-DC TB-8	151.5	46	76	M4-F	88.6	6

Schmalz –  
The Company

Vacuum  
Suction Cups

Special  
Grippers

Gripping  
Systems

Clamping  
Systems

Mounting  
Elements

Vacuum  
Generators

Valve  
Technology

Switches and  
Monitoring

Filters and  
Connections

Services

Contact

Glossary

Index of  
Products



# Vacuum Unit VAGG

Suction capacities of 6, 18, 40 and 63 m<sup>3</sup>/h

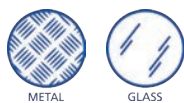

## Suitability for Industry Specific Applications

### Applications

- Vacuum unit based on an oil-lubricated vacuum pump with vacuum and liquid reservoirs
- Simple and quick to install; ideal for end users who use vacuum as one of many clamping technologies
- Vacuum supply of several machines in rotation possible
- Visual and audible system monitoring
- Designed to be integrated in the machine control of the CNC machining center



Vacuum Unit VAGG

### Design

- Drop separator (1) for separation of condensate
- Ball valve (2) for turning the vacuum on / off
- Vacuum gauge (manometer) (3) for visual vacuum inspection
- Drain valve (4) for manual drainage of liquid
- Vacuum pump (5) and power switch (6)
- Vacuum and liquid storage (7), as well as roles (8) for mobile use of VAGG

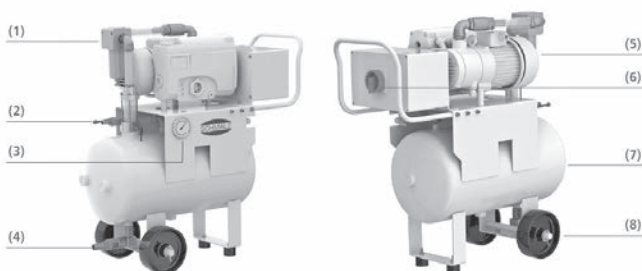

System Design Vacuum Unit VAGG



Vacuum unit VAGG for vacuum generation in wet machining

### Our Highlights...

- Automatic emergency off function
- Integrated manometer, vacuum switch, optical level indicator with electronic swimming switch and warning device
- Digital output warns against loss of vacuum and critical fluid level during the machining

### Your Benefits...

- Protects the pump against drawn-in fluids
- Visible and audible monitoring of the vacuum level and the fluid level
- Due to synchronization with machine control the machining will be stopped in case of loss of clamping force



- Schmalz – The Company
- Vacuum Suction Cups
- Special Grippers
- Gripping Systems
- Clamping Systems
- Mounting Elements
- Vacuum Generators
- Valve Technology
- Switches and Monitoring
- Filters and Connections
- Services
- Contact
- Glossary
- Index of Products



# Vacuum Unit VAGG

Suction capacities of 6, 18, 40 and 63 m<sup>3</sup>/h

## Designation Code Vacuum Unit VAGG



### 1 – Abbreviated designation

Code	Version
VAGG	VAGG

### 2 – Performance class

Code	Suction rate in m <sup>3</sup> /h
6...63	6 to 63

### 3 – Current Type

Code	Type
AC3	Three-phase

### 4 – Vacuum / Liquid reservoir

Code	Volume in l
10	10 to 80

### 5 – Product addition

Code	Certification
UC	UL / CSA certified

Vacuum unit VAGG is delivered as a ready-to-connect product.

## Ordering Data Vacuum Unit VAGG

Type	Part no.
VAGG 6 AC3 10	10.01.27.00120
VAGG 6 AC3 10 UC	10.01.27.00798
VAGG 18 AC3 30	10.01.27.00121
VAGG 18 AC3 30 UC	10.01.27.00799
VAGG 40 AC3 80	10.01.27.00122
VAGG 63 AC3 80	10.01.27.00123

## Technical Data Vacuum Unit VAGG

Type	Weight [kg]	Reservoir volume [l]	Suction rate (max.) [m <sup>3</sup> /h]	Voltage 50 Hz	Voltage 60 Hz	Rated power 50 Hz [kW]	Rated power 60 Hz [kW]	Protection type IP
VAGG 6 AC3 10	30	10	6	400V - AC3 V	460V - 3-phase AC V	0.25	0.30	54
VAGG 6 AC3 10 UC	30	10	6	400V - AC3 V	460V - 3-phase AC V	0.25	0.30	54
VAGG 18 AC3 30	48	30	18	400V - AC3 V	460V - 3-phase AC V	0.56	0.66	54
VAGG 18 AC3 30 UC	49	30	18	400V - AC3 V	460V - 3-phase AC V	0.56	0.66	54
VAGG 40 AC3 80	85	80	40	400V - AC3 V	460V - 3-phase AC V	1.40	1.70	54
VAGG 63 AC3 80	100	80	63	400V - AC3 V	460V - 3-phase AC V	2.00	2.40	54

# Vacuum Unit VAGG

Suction capacities of 6, 18, 40 and 63 m<sup>3</sup>/h



## Design Data Vacuum Unit VAGG

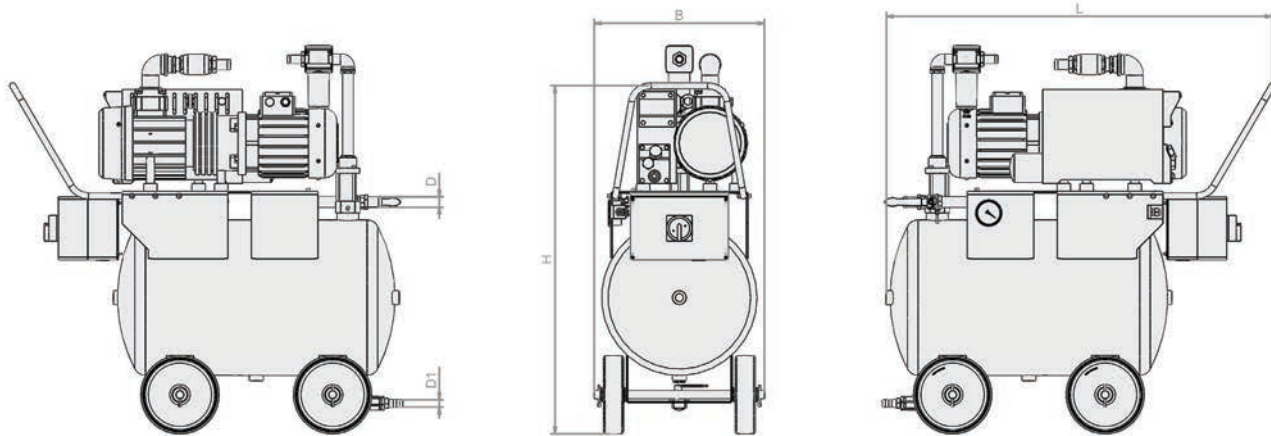

VAGG

Type	B [mm]	D [mm]	D1 [mm]	H [mm]	L [mm]
VAGG 6 AC3 10	250	12	12	600	55
VAGG 6 AC3 10 UC	250	12	12	600	55
VAGG 18 AC3 30	350	12	12	650	700
VAGG 18 AC3 30 UC	350	12	12	650	700
VAGG 40 AC3 80	500	25	25	850	800
VAGG 63 AC3 80	500	25	25	850	800



- Schmalz – The Company
- Vacuum Suction Cups
- Special Grippers
- Gripping Systems
- Clamping Systems
- Mounting Elements
- Vacuum Generators
- Valve Technology
- Switches and Monitoring
- Filters and Connections
- Services
- Contact
- Glossary
- Index of Products

# Vacuum Operation Center VOC

Suction capacities of 40, 63, 100 and 250 m<sup>3</sup>/h

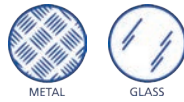

## Suitability for Industry Specific Applications

### Applications

- Vacuum Operation Center as a complete system ready to connect
- Specifically for evacuation of gaseous media containing liquids
- Liquid sucked in, such as cooling lubricants are separated and automatically returned to the machining cycle
- Audible, visual and electronic system monitoring for maximum security and control in standard machine operation



Vacuum Operation Center VOC

### Design

- Signal lamps and audible alarm sounds (1) and vacuum gauge (2) for vacuum level in reservoir
- Vacuum and liquid reservoir (3)
- Interface for automatic liquid recirculation (4)
- Water separator (5) for separation of remaining liquid
- Vacuum switch (6) with digital or analog output for the control; control panel (7) of self-sufficient execution
- Base frame (8) and vacuum pump (9) mounted on the back

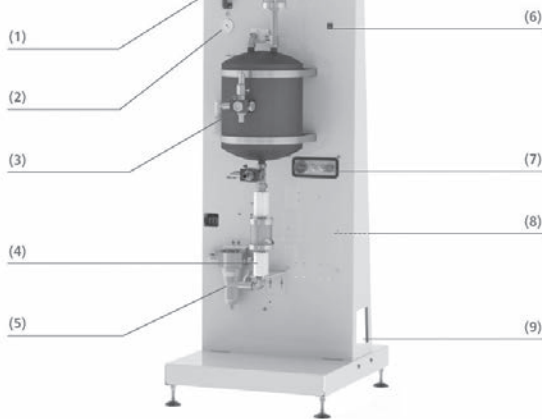

System Design Vacuum Operation Center VOC



Vacuum Operation Center for vacuum generation in wet working conditions

### Our Highlights...

- Automatic return of aspirated liquid to the machine's circulation
- Vacuum and fill level monitoring
- Integration of sensor and control signals into the machine controls via machine manufacturer possible

### Your Benefits...

- Uninterrupted machining even of large parts
- Automatic monitoring and control of the vacuum unit via the machine panel
- Comfortable operation and perfect process control

# Vacuum Operation Center VOC

Suction capacities of 40, 63, 100 and 250 m³/h

## Designation Code Vacuum Operation Center VOC



### 1 – Abbreviated designation

Code	Version
VOC	VOC

### 2 – Function

Code	Version
AD	Automatic emptying

### 3 – Type of control

Code	Version
S	SPS-controlled

### 4 – Performance class

Code	Suction rate in m³/h
40...100	40 to 100

### 5 – Product addition

Code	Operation mode
A	Self-sufficient

Vacuum-Operation-Center VOC is delivered as a ready-to-connect product.

## Ordering Data Vacuum Operation Center VOC

Type	Part no.
VOC-AD-S-40-A	10.01.27.00659
VOC-AD-S-63-A	10.01.27.00676
VOC-AD-S-100-A	10.01.27.00678

## Technical Data Vacuum Operation Center VOC

Type	Reservoir volume [l]	Voltage at 50 Hz	Rated power 50 Hz [kW]	Protection type IP	Suction rate (max.) [m³/h]	Weight [kg]
VOC-AD-S-40-A	60	400V - AC3	1.4	54	40	230
VOC-AD-S-63-A	60	400V - AC3	2.0	54	63	250
VOC-AD-S-100-A	60	400V - AC3	2.7	54	100	260

Schmalz – The Company  
Vacuum Suction Cups  
Special Grippers  
Gripping Systems  
Clamping Systems  
Mounting Elements  
Vacuum Generators  
Valve Technology  
Switches and Monitoring  
Filters and Connections  
Services  
Contact  
Glossary  
Index of Products

# Vacuum Operation Center VOC

Suction capacities of 40, 63, 100 and 250 m<sup>3</sup>/h



## Design Data Vacuum Operation Center VOC

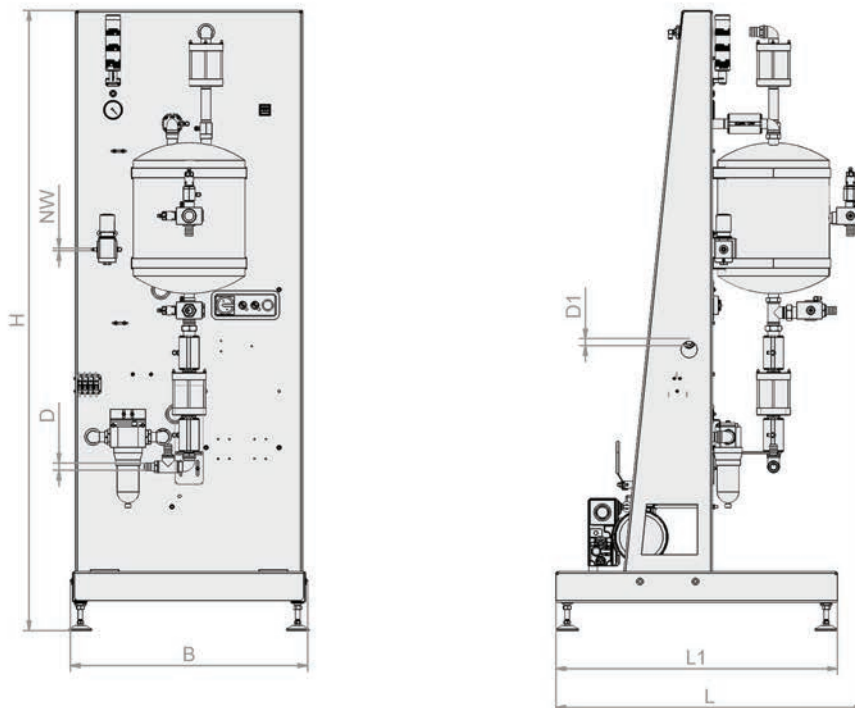

VOC

Type	B [mm]	D [mm]	D1 [mm]	L [mm]	L1 [mm]	H [mm]	NW [mm]
VOC-AD-S-40-A	840	25	25	1,095	1,000	2,200	7.2
VOC-AD-S-63-A	840	25	25	1,095	1,000	2,200	7.2
VOC-AD-S-100-A	840	25	25	1,095	1,000	2,200	7.2

Schmalz –  
The Company

Vacuum  
Suction Cups

Special  
Grippers

Gripping  
Systems

Clamping  
Systems

Mounting  
Elements

Vacuum  
Generators

Valve  
Technology

Switches and  
Monitoring

Filters and  
Connections

Services

Contact

Glossary

Index of  
Products



# Valve Technology

Schmalz –  
The Company

Vacuum  
Suction Cups

Special  
Grippers

Gripping  
Systems

Clamping  
Systems

Mounting  
Elements

Vacuum  
Generators

Valve  
Technology

Switches and  
Monitoring

Filters and  
Connections

Services

Contact

Glossary

Index of  
Products



## Selection Aid

Page



### Overview Valves

562

## Solenoid Valves



### Inline Valves IV

- Nominal diameter: 3 mm
- Nominal flow rate: 2 m<sup>3</sup>/h
- Voltage: 24 V



Inline valve in compact design for control of the vacuum directly on the suction cup.

563



### Solenoid Valves EMV

- Nominal diameter: 2 to 25 mm
- Nominal flow rate: 1 to 88 m<sup>3</sup>/h
- Voltages =/~ 24/230 V



Directly controlled vacuum valve with short opening and closing times, possible to control suction, venting and blow off of the suction cup.

566



### Solenoid Valves EMVO

- Nominal diameter: 12 to 25 mm
- Nominal flow rate: 21 to 101 m<sup>3</sup>/h
- Voltages =/~ 24/230 V



Directly controlled solenoid valve with large nominal diameter for high flow rates, possible to control suction and venting of the suction cup.

570



### Solenoid Valves EMVP

- Nominal diameter: 5 to 50 mm
- Nominal flow rate: 3 to 310 m<sup>3</sup>/h
- Voltages =/~ 24/230 V



Pneumatically controlled vacuum valve, extremely short opening and closing times; possible to control suction and venting of the suction cup.

573

# Overview of Section

At a Glance

## Check Valves and Flow Restrictors

Page

Schmalz – The Company  
Vacuum Suction Cups  
Special Grippers  
Gripping Systems  
Clamping Systems  
Mounting Elements  
Vacuum Generators  
Valve Technology  
Switches and Monitoring  
Filters and Connections  
Services  
Contact  
Glossary  
Index of Products



### Check Valves SVK, SVKG, SVV

- Max. blow off flow rate: 4.8 to 47.4 m<sup>3</sup>/h
- Connection thread: M5 to G1/2"



Vacuum valve for sealing the vacuum line as well as for reduction of the volume flow.

578



### Check Valves SVN

- Max. blow off flow rate: 27 m<sup>3</sup>/h
- Connection thread: G1/4"



Check valve with shaped nipple for direct connection to the suction cup, reduction of the volume flow.

581



### Flow Restrictors SW

- Nominal diameter: 0.25 to 2.0 mm



Flow resistance in minimum model size for reduction of the volume flow and maintenance of the vacuum if not all suction cups are covered.

584

## Touch Valves



### Touch Valves TV / TVN

- Flow rate: 0.7 to 9.6 m<sup>3</sup>/h
- Connection thread: G1/8" to G1/2"



Vacuum valve as spring-loaded sensing plunger for mechanically checking the coverage of the suction cup.

587

## Non-Return Valves



### Non-Return Valves RSV

- Nominal diameter: 6 to 54 mm
- Nominal flow rate: 5 to 350 m<sup>3</sup>/h
- Connection thread: G1/4" to G2"



Non-return valve with spring return safeguards the system in case of power failure or failure of the vacuum generator.

590

## Manually Actuated Valves



### Two-Way Ball Valves KVZ

- Nominal diameter: 8 to 50 mm
- Nominal flow rate: 10 to 310 m<sup>3</sup>/h



Manual two-way ball valve for switching entire vacuum, pressure circuits or individual suction cups on or off.

592

### Three-Way Ball Valves KVD

- Nominal diameter: 6 to 25 mm
- Nominal flow rate: 5 to 55 m<sup>3</sup>/h



Manual three-way ball valve for switching entire vacuum or pressure circuits or individual suction cups on or off.

594



At a Glance

	Page	
	<b>Manual Slide Valves HSV</b> <ul style="list-style-type: none"> <li>Nominal diameter: 7 to 24 mm</li> <li>Nominal flow rate: 6 to 50 m³/h</li> </ul>	<p>Manual sliding valve for manually switching entire vacuum or pressure circuits or individual suction cups on or off.</p>
		Schmalz – The Company
		Vacuum Suction Cups
		Special Grippers
		Gripping Systems
		Clamping Systems
		Mounting Elements
		Vacuum Generators
		<b>Valve Technology</b>
		Switches and Monitoring
		Filters and Connections
		Services
		Contact
		Glossary
		Index of Products

- Schmalz – The Company
- Vacuum Suction Cups
- Special Grippers
- Gripping Systems
- Clamping Systems
- Mounting Elements
- Vacuum Generators
- Valve Technology**
- Switches and Monitoring
- Filters and Connections
- Services
- Contact
- Glossary
- Index of Products

### Overview Valves

Application	Check valves	Flow restrictors	Sensing valves
Handling of porous workpieces such as chipboards and MDF panels	✓ (if type SVN is used)	✓	✓
Handling of airtight workpieces such as sheets of metal of varying sizes	✓		✓
Handling of cardboard sheets and boxes of varying sizes		✓	
Handling operations with very short cycle times	✓		✓
Cases where some of the suction cups are not fully in contact with the workpiece	✓	✓	
Cases where the workpiece is to be blown off for faster release	✓	✓ Restricted by the reduced cross-section	

# Inline Valves IV

Nominal diameter 3 mm



Inline Valves IV

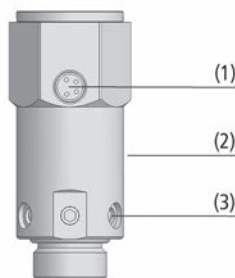

System Design Inline Valves IV



Suction cups with inline valves IV being used for handling carbody parts

## Suitability for Industry Specific Applications

### Applications

- Inline valve for deactivation of unused suction cups
- Individual control of the suction cups in a "vacuum carpet", e.g. when order picking
- System monitoring in vacuum spiders by activation and deactivation of suction cups

### Design

- Attachment facility for vacuum sensor
- External body made of aluminum (2)
- Integrated filter (3) for ventilation
- 4-pin M8 connector (1)
- Nominal diameter 3 mm; nominal flow rate 2 m<sup>3</sup>/h

### Our Highlights...

- Direct mounting in a suction cup
- Compact construction, simple installation
- Integrated filter screen to protect against dirt
- Decentralized vacuum control and system monitoring with a valve and an optional mini sensor

### Your Benefits...

- Individual control of single suction cups
- Minimum space requirements; simple installation
- Increased functional safety
- Improved process reliability and reduced standstill times of vacuum systems

# Inline Valves IV

Nominal diameter 3 mm



## Designation Code Inline Valves IV

<b>IV</b>	-	<b>3</b>	-	<b>3/2</b>	-	<b>G3/8-IG</b>	-	<b>G3/8-AG</b>	-	<b>24V-DC</b>
1		2		3		4		5		6

### 1 - Abbreviated designation

Code	Version
IV	IV

### 2 - Nozzle size

Code	Nozzle size in mm
3	3

### 3 - Variant

Code	Type
3/2	3/2-way valve

### 4 - Vacuum connection

Code	Connection
G1/4-IG	G1/4-IG (IG = female (F))
G3/8-IG	G3/8-IG

### 5 - Suction cup connection

Code	Connection
G3/8-AG	G3/8-AG (AG = male (M))

### 6 - Voltage

Code	Voltage in V
24V-DC	Direct current

Inline valve IV is delivered as a ready-to-connect product (without connection cable).

Available accessories: connection cable, vacuum sensors



## Ordering Data Inline Valves IV

Type	Part no.
IV 3 3/2 G1/4-IG G3/8-AG 24V-DC	10.05.01.00173
IV 3 3/2 G3/8-IG G3/8-AG 24V-DC	10.05.01.00172



## Ordering Data Accessories Inline Valves IV

Type*		Part no.
Connection cable, M8 4-pole, 5 m, PUR, straight	ASK B-M8-4 5000 K-4P	10.06.02.00031
Connection cable, M8 4-pole, 5 m, PUR, 90°	ASK WB-M8-4 5000 K-4P	10.06.02.00032
Vacuum sensor analog	VS-V-SA M5-AG	10.06.02.00224
Vacuum sensor digital	VS-V-SD 60 M5-AG	10.06.02.00257

\*See section "Switches and system monitoring" for further details



## Technical Data Inline Valves IV

Type	Nominal size [mm]	Control valve	Voltage	Nominal flow rate [l/min]	Nominal flow rate [m³/h]	Input DC [W]	Weight [kg]
IV 3 3/2 G1/4-IG G3/8-AG 24V-DC	3	Normally open	24V - DC V	34	2	4.5	0.074
IV 3 3/2 G3/8-IG G3/8-AG 24V-DC	3	Normally open	24V - DC V	34	2	4.5	0.074

# Inline Valves IV

Nominal diameter 3 mm



## Design Data Inline Valves IV

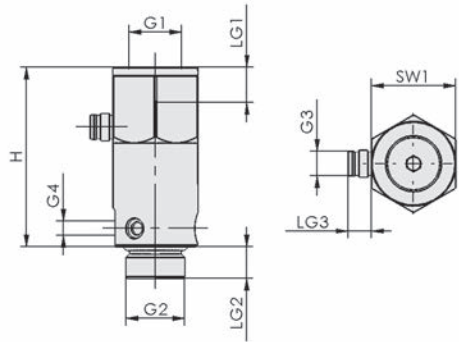

IV

Type	G1	G2	G3	G4	H [mm]	LG1 [mm]	LG2 [mm]	LG3 [mm]	SW1 [mm]
IV 3 3/2 G1/4-IG G3/8-AG 24V-DC	G1/4"-F	G3/8"-M	M8-M	M5-F	51	9	9	6.5	24
IV 3 3/2 G3/8-IG G3/8-AG 24V-DC	G3/8"-F	G3/8"-M	M8-M	M5-F	51	9	9	6.5	24

Schmalz –  
The Company

Vacuum  
Suction Cups

Special  
Grippers

Gripping  
Systems

Clamping  
Systems

Mounting  
Elements

Vacuum  
Generators

Valve  
Technology

Switches and  
Monitoring

Filters and  
Connections

Services

Contact

Glossary

Index of  
Products



# Solenoid Valves EMV

Nominal diameter from 2 mm to 25 mm



## Suitability for Industry Specific Applications

### Applications

- Control of vacuum, blow off and venting of the suction cup
- Control of compressed air or vacuum in lines with smaller cross sections
- NO function ensures workpiece is held even in the case of a power failure
- For handling tasks with short switching times
- Vacuum valve is suitable for neutral and filtered air

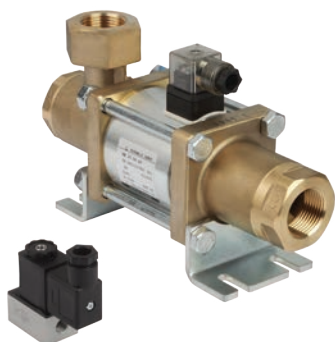

Solenoid Valves EMV

### Design

- Directly controlled solenoid valve
- Valve EMV 2 and EMV 3 always with NC switching function
- Degree of protection IP 65
- Connection socket complies with DIN 43 650, Form A
- Supplied complete with plug connector and (for DC operation) a quenching diode

### Our Highlights...

- Seat valve in robust metal housing
- Directly controlled
- 3/2-way valve (exception: EMV 3 is a 2/2-way valve)
- Switching function NO (exception: EMV 2 and EMV 3 are NC)

### Your Benefits...

- Suitable for vacuum and compressed air
- Short opening and closing times
- Control of on/off and venting functions
- Safety in the case of a power failure



## Designation Code Solenoid Valves EMV

<b>EMV</b>	-	<b>5</b>	-	<b>24V-DC</b>	-	<b>3/2</b>	-	<b>NO</b>
<b>1</b>		<b>2</b>		<b>3</b>		<b>4</b>		<b>5</b>

#### 1 - Abbreviated designation

Code	Version
EMV	EMV

#### 2 - Nozzle size

Code	Nozzle size in mm
2...25	2 to 25

#### 3 - Voltage

Code	Voltage in V
24V-DC	Direct current
230V-AC	Single phase

#### 4 - Variant

Code	Type
2/2	2/2-way valve
3/2	3/2-way valve

#### 5 - Idle position suction valve

Code	Type
NC	Normally closed
NO	Normally open

Solenoid valve EMV is delivered as a ready-to-connect product.

Available accessories: venting filter



# Solenoid Valves EMV

Nominal diameter from 2 mm to 25 mm



## Ordering Data Solenoid Valves EMV

Type	Part no.
EMV 2 24V-DC 3/2 NC	10.05.01.00290
EMV 3 230V-AC 2/2 NC	10.05.01.00067
EMV 3 24V-DC 2/2 NC	10.05.01.00066
EMV 5 230V-AC 3/2 NO	10.05.01.00069
EMV 5 24V-DC 3/2 NO	10.05.01.00068
EMV 10 230V-AC 3/2 NO	10.05.01.00071
EMV 10 24V-DC 3/2 NO	10.05.01.00070
EMV 15 230V-AC 3/2 NO	10.05.01.00073
EMV 15 24V-DC 3/2 NO	10.05.01.00072
EMV 20 230V-AC 3/2 NO	10.05.01.00075
EMV 20 24V-DC 3/2 NO	10.05.01.00074
EMV 25 24V-DC 3/2 NO	10.05.01.00076
EMV 25 230V-AC 3/2 NO	10.05.01.00077



## Ordering Data Accessories Solenoid Valves EMV

Type	Accessories	Part no.
EMV 5	Venting filter FAS 63x19 G1/4-AG	10.05.01.00060
EMV 10	Venting filter FAS 80x33.8 G1/2-AG	10.05.01.00061
EMV 15	Venting filter FAS 80x39 G3/4-AG	10.05.01.00062
EMV 20	Venting filter FAS 80x38 G1-AG EMVP	10.05.01.00063
EMV 25	Venting filter FAS 80x32 G1-1/4-AG EMVP-25+50	10.05.01.00064



## Technical Data Solenoid Valves EMV

Type	Nominal size [mm]	Control valve	Nominal flow rate [l/min]	Nominal flow rate [m³/h]	Input DC [W]	Closing time [ms]	Weight [kg]
EMV	2	Normally closed	17	1	2.2	10	0.150
EMV	3	Normally closed	34	2	5.0	20	0.200
EMV	5	Normally open	67	4	8.0	20	0.518
EMV	10	Normally open	334	20	32.0	25	2.510
EMV	15	Normally open	567	34	38.4	80	4.665
EMV	20	Normally open	884	53	40.8	100	6.375
EMV	25	Normally open	1,467	88	63.8	135	9.600

# Solenoid Valves EMV

Nominal diameter from 2 mm to 25 mm



## Design Data Solenoid Valves EMV

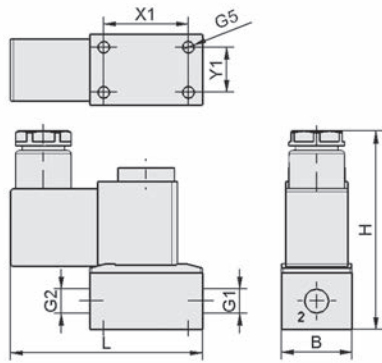

EMV 2

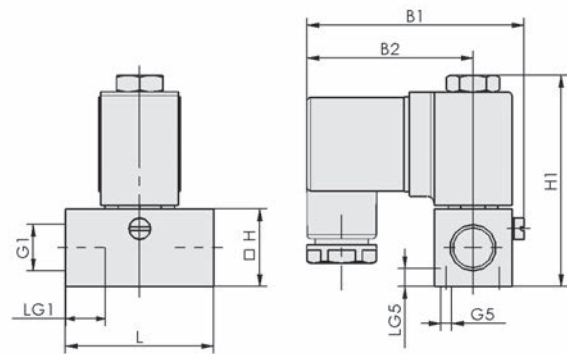

EMV 3

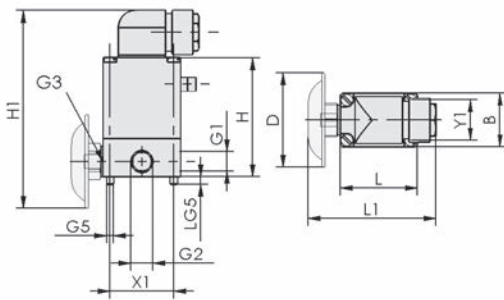

EMV 5

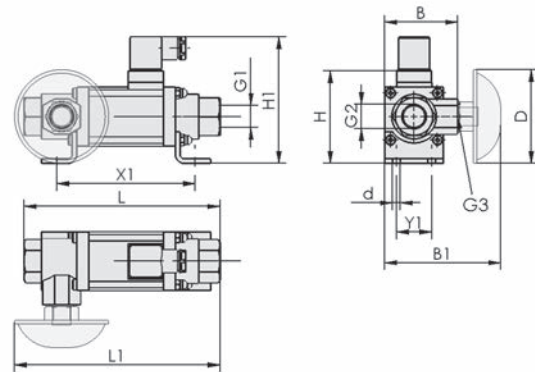

EMV 10

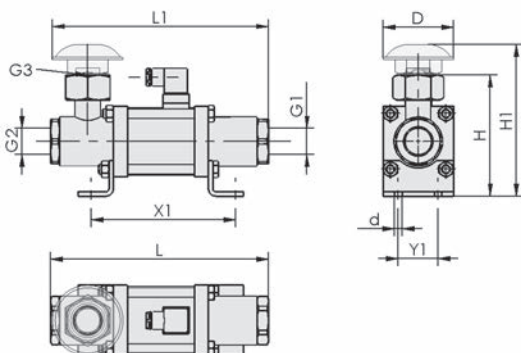

EMV 15 - 25



- Schmalz - The Company
- Vacuum Suction Cups
- Special Grippers
- Gripping Systems
- Clamping Systems
- Mounting Elements
- Vacuum Generators
- Valve Technology
- Switches and Monitoring
- Filters and Connections
- Services
- Contact
- Glossary
- Index of Products



# Solenoid Valves EMV

Nominal diameter from 2 mm to 25 mm



## Design Data Solenoid Valves EMV

Type	B [mm]	B1 [mm]	B2 [mm]	d [mm]	D [mm]	G1	G2	G3	G5	H [mm]	H1 [mm]	L [mm]	L1 [mm]	LG1 [mm]	LG5 [mm]	X1 [mm]	Y1 [mm]
EMV 2	25	-	-	-	-	G1/8"-F	G1/8"-F	-	M5-F	70	-	68.0	-	-	-	30.0	16
EMV 3	-	61.5	47	-	-	G1/4"-F	-	-	M3-F	22	60.0	42.0	-	12	5	-	-
EMV 5	32	-	-	-	56	G1/4"-F	G1/4"-F	G1/4"-F	M4-F	71	118.0	46.0	76.0	-	5	38.0	24
EMV 10	62	98.5	-	7.0	80	G1/2"-F	G1/2"-F	G1/2"-F	-	79	108.0	166.5	174.5	-	-	117.5	30
EMV 15	-	-	-	6.5	80	G3/4"-F	G3/4"-F	G3/4"-F	-	114	140.0	209.0	211.0	-	-	133.0	40
EMV 20	-	-	-	8.5	80	G1"-F	G1"-F	G1"-F	-	137	172.0	247.0	245.0	-	-	148.0	45
EMV 25	-	-	-	8.5	80	G1-1/4"-F	G1-1/4"-F	G1-1/4"-F	-	167	200.0	281.0	271.5	-	-	178.0	50

Schmalz –  
The Company

Vacuum  
Suction Cups

Special  
Grippers

Gripping  
Systems

Clamping  
Systems

Mounting  
Elements

Vacuum  
Generators

Valve  
Technology

Switches and  
Monitoring

Filters and  
Connections

Services

Contact

Glossary

Index of  
Products



# Solenoid Valves EMVO

Nominal diameter from 12 mm to 25 mm



## Suitability for Industry Specific Applications

### Applications

- Solenoid valve for use at high volume flow rates in systems with large cross sections
- Control of vacuum and venting of the suction cup
- Suitable for neutral or filtered air



Solenoid Valves EMVO

### Design

- Directly controlled solenoid valve
- Switching function (NC)
- Seat valve in housing made of brass and aluminum
- Degree of protection IP 65
- Connection socket complies with DIN 43 650, Form A
- Supplied complete with plug connector

### Our Highlights...

- 3/2-way valve
- Valve with large nominal diameter
- Directly controlled

### Your Benefits...

- Control of vacuum on/off or venting function
- Suitable for lines with large nominal flow rates
- Short opening and closing times



## Designation Code Solenoid Valves EMVO

<b>EMVO</b>	-	<b>12</b>	-	<b>230V-AC</b>	-	<b>3/2</b>	-	<b>NC</b>
<b>1</b>		<b>2</b>		<b>3</b>		<b>4</b>		<b>5</b>

#### 1 - Abbreviated designation

Code	Version
EMVO	EMVO

#### 2 - Nozzle size

Code	Nozzle size in mm
12...25	12 to 25

#### 3 - Voltage

Code	Voltage in V
24V-DC	Direct current
230V-AC	Single phase

#### 4 - Variant

Code	Type
3/2	3/2-way valve

#### 5 - Idle position suction valve

Code	Type
NC	Normally closed
NO	Normally open

Solenoid valve EMVO is delivered as a ready-to-connect product.

Available accessories: venting filter

Schmalz - The Company  
Vacuum Suction Cups  
Special Grippers  
Gripping Systems  
Clamping Systems  
Mounting Elements  
Vacuum Generators  
Valve Technology  
Switches and Monitoring  
Filters and Connections  
Services  
Contact  
Glossary  
Index of Products

# Solenoid Valves EMVO

Nominal diameter from 12 mm to 25 mm



## Ordering Data Solenoid Valves EMVO

Type	Part no.
EMVO 12 230V-AC 3/2 NC	10.05.01.00052
EMVO 12 24V-DC 3/2 NC	10.05.01.00049
EMVO 20 230V-AC 3/2 NC	10.05.01.00053
EMVO 20 24V-DC 3/2 NC	10.05.01.00050
EMVO 25 24V-DC 3/2 NC	10.05.01.00051



## Ordering Data Accessories Solenoid Valves EMVO

Type	Accessories	Part no.
EMVO 12 230V-AC 3/2 NC	Venting filter FAS 80x33.8 G1/2-AG	10.05.01.00061
EMVO 12 24V-DC 3/2 NC	Venting filter FAS 80x33.8 G1/2-AG	10.05.01.00061
EMVO 20 230V-AC 3/2 NC	Venting filter FAS 80x39 G3/4-AG	10.05.01.00062
EMVO 20 24V-DC 3/2 NC	Venting filter FAS 80x39 G3/4-AG	10.05.01.00062
EMVO 25 24V-DC 3/2 NC	Venting filter FAS 80x38 G1-AG EMVP	10.05.01.00063



## Technical Data Solenoid Valves EMVO

Type	Control valve	Nominal flow rate [m <sup>3</sup> /h]	Nominal flow rate [l/min]	Power consumption DC [W]	Power consumption AC [W]	Weight [kg]
EMVO 12 230V-AC 3/2 NC	Normally closed	21	350	-	39.1	1.2
EMVO 12 24V-DC 3/2 NC	Normally closed	21	350	31.9	-	1.2
EMVO 20 230V-AC 3/2 NC	Normally closed	72	1,200	-	36.8	5.8
EMVO 20 24V-DC 3/2 NC	Normally closed	72	1,200	40.8	-	5.8
EMVO 25 24V-DC 3/2 NC	Normally closed	101	1,684	40.8	-	5.7

# Solenoid Valves EMVO

Nominal diameter from 12 mm to 25 mm

**Design Data Solenoid Valves EMVO**

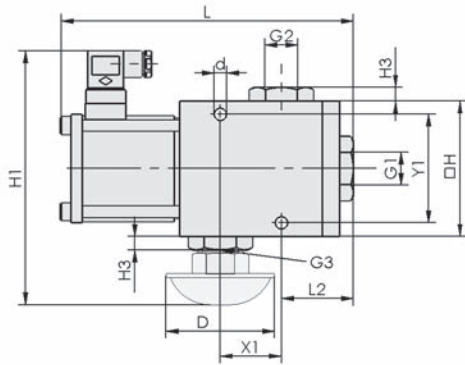

EMVO

Type	d [mm]	D [mm]	G1	G2	G3	H [mm]	H1 [mm]	H3 [mm]	L [mm]	L2 [mm]	X1 [mm]	Y1 [mm]
EMVO 12 230V-AC 3/2 NC	6.5	80	G1/2"-F	G1/2"-F	G1/2"-F	60	135.5	-	122	32	24	40
EMVO 12 24V-DC 3/2 NC	6.5	80	G1/2"-F	G1/2"-F	G1/2"-F	60	135.5	-	122	32	24	40
EMVO 20 230V-AC 3/2 NC	9.0	80	G3/4"-F	G3/4"-F	G3/4"-F	100	187.5	10	206	43	45	80
EMVO 20 24V-DC 3/2 NC	9.0	80	G3/4"-F	G3/4"-F	G3/4"-F	100	187.5	10	206	43	45	80
EMVO 25 24V-DC 3/2 NC	9.0	80	G1"-F	G1"-F	G1"-F	100	172.0	-	206	43	45	80

Schmalz - The Company  
Vacuum Suction Cups  
Special Grippers  
Gripping Systems  
Clamping Systems  
Mounting Elements  
Vacuum Generators  
Valve Technology  
Switches and Monitoring  
Filters and Connections  
Services  
Contact  
Glossary  
Index of Products

# Solenoid Valves EMVP

Nominal diameter from 5 mm to 50 mm



## Suitability for Industry Specific Applications



Solenoid Valves EMVP

### Applications

- Solenoid valve for control at high nominal flow rates
- Control of vacuum, blow off and venting of the suction cup
- NO function ensures the workpiece is held even in the case of a power failure
- For handling tasks with very short switching times
- Vacuum valve suitable for neutral or filtered gases

### Design

- Solenoid valve with pneumatic pilot control
- Seat valve in aluminum housing (EMVP 5-15) as well as plastic housing EMVP 20 to 50
- Degree of protection IP 65 according to EN 60529
- Terminal box EMVP 5/8 and all IMPs conform with DIN EN 175301 Form "C"
- Terminal box EMVP 10-25 NO/NC conforms with DIN 43650 Form "B"
- Terminal box EMVP 32-50 NO conforms with DIN 43650 Form "B"

### Our Highlights...

- Pilot control with compressed air (p = 5 bar)
- Wide range of nominal diameters
- 3/2- and 5/2-way valve
- Bistable impulse valve (only for IMP version)

### Your Benefits...

- Extremely short opening and closing times
- Also suitable for high volume flow rates
- Control of vacuum on/off or venting functions
- Prevention of air consumption in case of power failures



## Designation Code Solenoid Valves EMVP

<b>EMVP</b>	-	<b>15</b>	-	<b>24V-DC</b>	-	<b>3/2</b>	-	<b>NC</b>
<b>1</b>		<b>2</b>		<b>3</b>		<b>4</b>		<b>5</b>

#### 1 – Abbreviated designation

Code	Version
EMVP	EMVP

#### 2 – Nozzle size

Code	Nozzle size in mm
5...50	5 to 50

#### 3 – Voltage

Code	Voltage in V
24V-DC	Direct current
230V-AC	Single phase

#### 4 – Variant

Code	Type
3/2	3/2-way valve
5/2	5/2-way valve

#### 5 – Idle position suction valve

Code	Type
IMP	Bistable switched with pulse
NC	Normally closed
NO	Normally open

Solenoid valve EMVP is delivered as a ready-to-connect product.

Available accessories: venting filter, connection cable for solenoid valves, socket with M12 connection



Schmalz – The Company  
Vacuum Suction Cups  
Special Grippers  
Gripping Systems  
Clamping Systems  
Mounting Elements  
Vacuum Generators  
Valve Technology  
Switches and Monitoring  
Filters and Connections  
Services  
Contact  
Glossary  
Index of Products

# Solenoid Valves EMVP

Nominal diameter from 5 mm to 50 mm



## Ordering Data Solenoid Valves EMVP

Type	Part no.
EMVP 5 24V-DC 3/2 NC	10.05.02.00162
EMVP 5 24V-DC 5/2 IMP	10.05.02.00163
EMVP 8 24V-DC 3/2 NC	10.05.02.00164
EMVP 8 24V-DC 5/2 IMP	10.05.02.00165
EMVP 10 230V-AC 3/2 NO/NC	10.05.02.00143
EMVP 10 24V-DC 3/2 NO/NC	10.05.02.00144
EMVP 15 230V-AC 3/2 NO/NC	10.05.02.00145
EMVP 15 24V-DC 3/2 NO/NC	10.05.02.00146
EMVP 15 24V-DC 3/2 IMP	10.05.02.00147
EMVP 20 230V-AC 3/2 NO/NC	10.05.02.00148
EMVP 20 24V-DC 3/2 NO/NC	10.05.02.00149
EMVP 20 24V-DC 3/2 IMP	10.05.02.00167
EMVP 25 230V-AC 3/2 NO/NC	10.05.02.00150
EMVP 25 24V-DC 3/2 NO/NC	10.05.02.00151
EMVP 25 24V-DC 3/2 IMP	10.05.02.00152
EMVP 32 230V-AC 3/2 NO	10.05.02.00074
EMVP 32 24V-DC 3/2 NO	10.05.02.00068
EMVP 50 230V-AC 3/2 NO	10.05.02.00075
EMVP 50 24V-DC 3/2 NO	10.05.02.00069



## Ordering Data Accessories Solenoid Valves EMVP

Type	Venting filter	Socket with M12-connection	Connection cable for solenoid valves (5 m, PVC)
EMVP 5 24V-DC 3/2 NC	-	-	21.04.06.00084
EMVP 5 24V-DC 5/2 IMP	-	-	21.04.06.00084
EMVP 8 24V-DC 3/2 NC	-	-	21.04.06.00084
EMVP 8 24V-DC 5/2 IMP	-	-	21.04.06.00084
EMVP 10 24V-DC 3/2 NO/NC	10.05.01.00065	10.05.02.00157	-
EMVP 10 230V-AC 3/2 NO/NC	10.05.01.00065	-	-
EMVP 15 24V-DC 3/2 NO/NC	10.05.01.00061	10.05.02.00157	-
EMVP 15 24V-DC 3/2 IMP	10.05.01.00061	-	21.04.06.00084
EMVP 15 230V-AC 3/2 NO/NC	10.05.01.00061	-	-
EMVP 20 24V-DC 3/2 NO/NC	10.05.01.00062	10.05.02.00157	-
EMVP 20 24V-DC 3/2 IMP	10.05.01.00062	-	21.04.06.00084
EMVP 20 230V-AC 3/2 NO/NC	10.05.01.00062	-	-
EMVP 25 24V-DC 3/2 NO/NC	10.05.01.00063	10.05.02.00157	-
EMVP 25 24V-DC 3/2 IMP	10.05.01.00063	-	21.04.06.00084
EMVP 25 230V-AC 3/2 NO/NC	10.05.01.00063	-	-
EMVP 32 24V-DC 3/2 NO	10.05.01.00062	10.05.02.00157	-
EMVP 32 230V-AC 3/2 NO	10.05.01.00062	-	-
EMVP 50 24V-DC 3/2 NO	10.05.01.00064	-	-
EMVP 50 230V-AC 3/2 NO	10.05.01.00064	-	-



Nominal diameter from 5 mm to 50 mm



## Technical Data Solenoid Valves EMVP

Type	Nominal size [mm]	Control valve	Nominal flow rate [m³/h]	Nominal flow rate [l/min]	Power consumption DC [W]	Closing time [ms]	Weight [kg]
EMVP 5 24V-DC 3/2 NC	5	Normally closed	3	50	1	19	0.11
EMVP 5 24V-DC 5/2 IMP	5	Double pilot valve	3	50	1	13	0.16
EMVP 8 24V-DC 3/2 NC	8	Normally closed	6	100	1	19	0.15
EMVP 8 24V-DC 5/2 IMP	8	Double pilot valve	6	100	1	11	0.27
EMVP 10 230V-AC 3/2 NO/NC	10	Optionally NO/NC	10	167	5	22	0.42
EMVP 10 24V-DC 3/2 NO/NC	10	Optionally NO/NC	10	167	5	22	0.42
EMVP 15 230V-AC 3/2 NO/NC	15	Optionally NO/NC	20	333	5	90	0.39
EMVP 15 24V-DC 3/2 NO/NC	15	Optionally NO/NC	20	333	5	90	0.39
EMVP 15 24V-DC 3/2 IMP	15	Double pilot valve	20	333	5	110	0.56
EMVP 20 24V-DC 3/2 NO/NC	20	Optionally NO/NC	40	667	5	90	0.37
EMVP 20 230V-AC 3/2 NO/NC	20	Optionally NO/NC	40	667	5	90	0.37
EMVP 20 24V-DC 3/2 IMP	20	Double pilot valve	40	667	5	110	0.53
EMVP 25 230V-AC 3/2 NO/NC	25	Optionally NO/NC	90	1,500	5	80	0.52
EMVP 25 24V-DC 3/2 NO/NC	25	Optionally NO/NC	90	1,500	5	80	0.52
EMVP 25 24V-DC 3/2 IMP	25	Double pilot valve	90	1,500	5	100	0.68
EMVP 32 230V-AC 3/2 NO	32	Normally open	130	2,167	5	300	0.50
EMVP 32 24V-DC 3/2 NO	32	Normally open	130	2,167	5	300	0.50
EMVP 50 230V-AC 3/2 NO	50	Normally open	310	5,167	5	500	1.36
EMVP 50 24V-DC 3/2 NO	50	Normally open	310	5,167	5	500	1.36



## Design Data Solenoid Valves EMVP

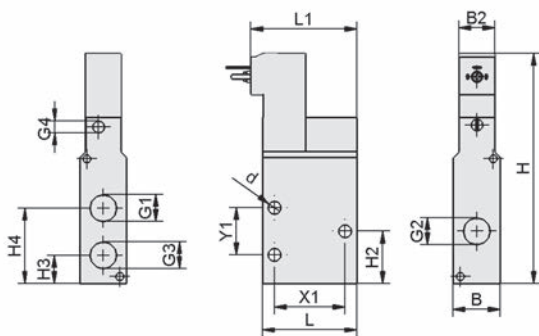

EMVP 5 - 8 NC

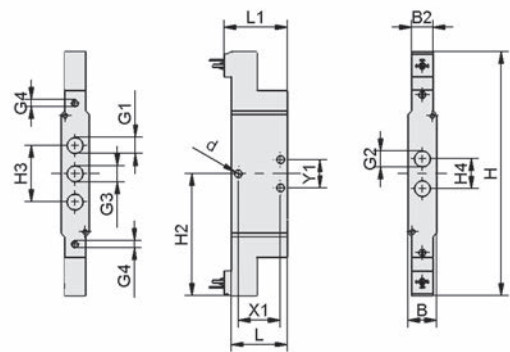

EMVP 5 - 8 IMP

# Solenoid Valves EMVP

Nominal diameter from 5 mm to 50 mm

**Design Data Solenoid Valves EMVP**

- Schmalz – The Company
- Vacuum Suction Cups
- Special Grippers
- Gripping Systems
- Clamping Systems
- Mounting Elements
- Vacuum Generators
- Valve Technology
- Switches and Monitoring
- Filters and Connections
- Services
- Contact
- Glossary
- Index of Products

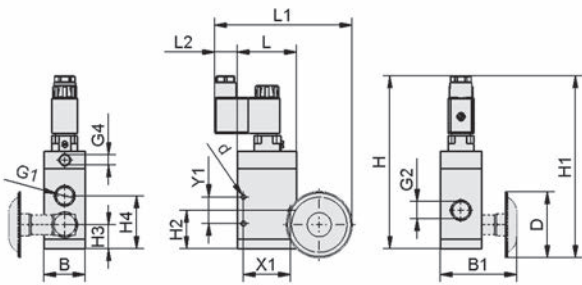

EMVP 10

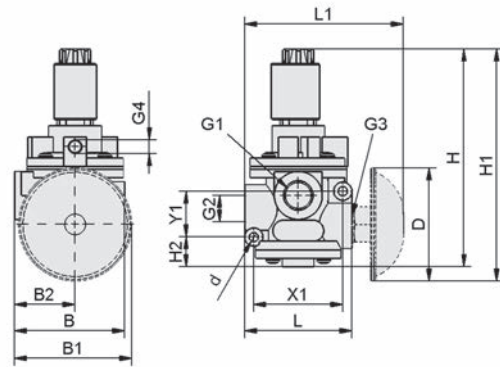

EMVP 15, 20, 25 NO/NC

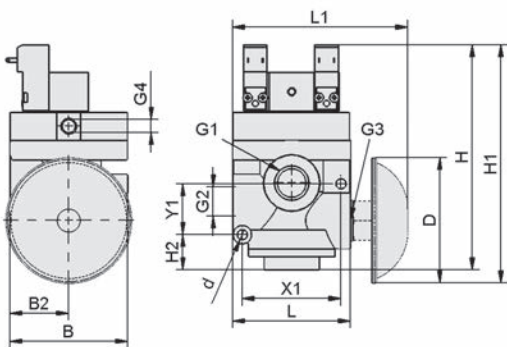

EMVP 15, 20, 25 IMP

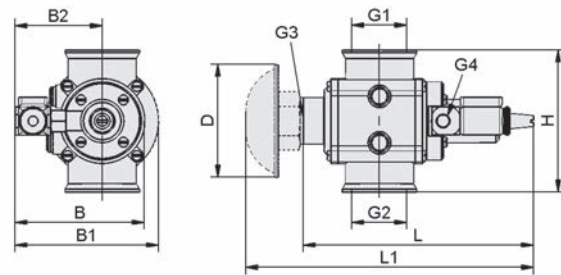

EMVP 32, EMVP 50



# Solenoid Valves EMVP

Nominal diameter from 5 mm to 50 mm



## Design Data Solenoid Valves EMVP

Type	B [mm]	B1 [mm]	B2 [mm]	d [mm]	D [mm]	G1	G2	G3	G4
EMVP 5 24V-DC 3/2 NC	15.0	-	15.0	4.3	-	G1/8"-F	G1/8"-F	G1/8"-F	M5-F
EMVP 5 24V-DC 5/2 IMP	15.2	-	15.2	4.3	-	G1/8"-F	G1/8"-F	G1/8"-F	M5-F
EMVP 8 24V-DC 3/2 NC	20.0	-	15.2	5.5	-	G1/4"-F	G1/4"-F	G1/4"-F	M5-F
EMVP 8 24V-DC 5/2 IMP	20.0	-	15.2	5.5	-	G1/4"-F	G1/4"-F	G1/4"-F	M5-F
EMVP 10 230V-AC 3/2 NO/NC	35.0	67	-	4.3	56	G3/8"-F	G3/8"-F	-	G1/8"-F
EMVP 10 24V-DC 3/2 NO/NC	35.0	67	-	4.3	56	G3/8"-F	G3/8"-F	-	G1/8"-F
EMVP 15 230V-AC 3/2 NO/NC	75.0	78	37.5	6.5	80	G1/2"-F	G1/2"-F	G1/2"-F	G1/8"-F
EMVP 15 24V-DC 3/2 NO/NC	75.0	78	37.5	6.5	80	G1/2"-F	G1/2"-F	G1/2"-F	G1/8"-F
EMVP 15 24V-DC 3/2 IMP	75.0	-	37.5	6.5	80	G1/2"-F	G1/2"-F	G1/2"-F	G1/8"-F
EMVP 20 24V-DC 3/2 NO/NC	75.0	78	37.5	6.5	80	G3/4"-F	G3/4"-F	G3/4"-F	G1/8"-F
EMVP 20 230V-AC 3/2 NO/NC	75.0	78	37.5	6.5	80	G3/4"-F	G3/4"-F	G3/4"-F	G1/8"-F
EMVP 20 24V-DC 3/2 IMP	75.0	-	37.5	6.5	80	G3/4"-F	G3/4"-F	G3/4"-F	G1/8"-F
EMVP 25 230V-AC 3/2 NO/NC	94.0	87	47.0	8.0	80	G1"-F	G1"-F	G1"-F	G1/8"-F
EMVP 25 24V-DC 3/2 NO/NC	94.0	87	47.0	8.0	80	G1"-F	G1"-F	G1"-F	G1/8"-F
EMVP 25 24V-DC 3/2 IMP	94.0	-	47.0	8.0	80	G1"-F	G1"-F	G1"-F	G1/8"-F
EMVP 32 230V-AC 3/2 NO	90.5	101	61.5	-	80	G1-1/4"-F	G1-1/4"-F	G3/4"-F	G1/8"-F
EMVP 32 24V-DC 3/2 NO	124.7	135	94.7	-	80	G1-1/4"-F	G1-1/4"-F	G3/4"-F	G1/8"-F
EMVP 50 230V-AC 3/2 NO	114.0	151	105.5	-	80	G2"-F	G2"-F	G1-1/4"-F	G1/8"-F
EMVP 50 24V-DC 3/2 NO	114.0	151	105.5	-	80	G2"-F	G2"-F	G1-1/4"-F	G1/8"-F

Type	H [mm]	H1 [mm]	H2 [mm]	H3 [mm]	H4 [mm]	L [mm]	L1 [mm]	X1 [mm]	Y1 [mm]
EMVP 5 24V-DC 3/2 NC	89	-	20	12.0	27	32	37	23	15
EMVP 5 24V-DC 5/2 IMP	153	-	77	30.0	15	32	37	23	15
EMVP 8 24V-DC 3/2 NC	98	-	23	12.0	32	40	45	30	20
EMVP 8 24V-DC 5/2 IMP	173	-	87	40.0	21	40	45	30	20
EMVP 10 230V-AC 3/2 NO/NC	147	154.5	33	20.5	45	50	117	40	23
EMVP 10 24V-DC 3/2 NO/NC	147	154.5	33	20.5	45	50	117	40	23
EMVP 15 230V-AC 3/2 NO/NC	167	173.8	23	-	-	75	112	63	33
EMVP 15 24V-DC 3/2 NO/NC	167	173.8	23	-	-	75	112	63	33
EMVP 15 24V-DC 3/2 IMP	144	152.1	23	-	-	75	112	63	33
EMVP 20 24V-DC 3/2 NO/NC	167	178.3	23	-	-	75	116	63	33
EMVP 20 230V-AC 3/2 NO/NC	167	178.3	23	-	-	75	116	63	33
EMVP 20 24V-DC 3/2 IMP	144	152.1	23	-	-	75	116	63	33
EMVP 25 230V-AC 3/2 NO/NC	190	195.5	22	-	-	94	132	76	37
EMVP 25 24V-DC 3/2 NO/NC	190	195.5	22	-	-	94	132	76	37
EMVP 25 24V-DC 3/2 IMP	167	173.8	22	-	-	94	132	76	37
EMVP 32 230V-AC 3/2 NO	101	-	-	-	-	163	204	-	-
EMVP 32 24V-DC 3/2 NO	101	-	-	-	-	160	201	-	-
EMVP 50 230V-AC 3/2 NO	142	-	-	-	-	225	260	-	-
EMVP 50 24V-DC 3/2 NO	142	-	-	-	-	225	260	-	-

Schmalz –  
The CompanyVacuum  
Suction CupsSpecial  
GrippersGripping  
SystemsClamping  
SystemsMounting  
ElementsVacuum  
GeneratorsValve  
TechnologySwitches and  
MonitoringFilters and  
Connections

Services

Contact

Glossary

Index of  
Products

# Check Valves SVK, SVKG, SVV

Connection thread from M5 to G1/2"



## Suitability for Industry Specific Applications

### Applications

- Check valve for applications where some of the suction cups may not be in contact with the workpiece
- Deactivation of unused suction cups, the system vacuum is maintained
- Handling of workpieces with varying sizes and shapes with the same gripping system



Check Valves SVK, SVKG, SVV

### Design

- Ball seat valve
- Ball in brass seat, installed in a space saving manner in an aluminum body
- On the type SVV, the flow rate can be adjusted continuously with an adjusting screw
- Suitable for installation in any orientation

### Our Highlights...

- Check valve in the form of a ball seat valve
- Reaction dependent on the volume flow rate
- Wide range of nominal sizes
- Available with male thread at the top (type SVK) or bottom (type SVKG)

### Your Benefits...

- Closing of vacuum lines leading to unused suction cups to maintain the system vacuum
- Low leakage rate which can be compensated with the aid of a bypass
- Also suitable for use in applications with high nominal flow rates
- Can be connected to all common suction cups and plates



## Designation Code Check Valves SVK, SVKG, SVV

<b>SVK</b>	–	<b>M5-IG</b>
<b>1</b>		<b>2</b>

#### 1 – Abbreviated designation

Code	Version
SVK	Male thread at the top
SVKG	Male thread at the bottom
SVV	Adjusting screw

#### 2 – Connection

Code	Connection
M5-AG	M5-AG (AG = male (M))
M5-IG	M5-IG (IG = female (F))
G1/8-AG	G1/8-AG
G1/8-IG	G1/8-IG
G1/4-AG	G1/4-AG
G1/4-IG	G1/4-IG
G3/8-AG	G3/8-AG
G3/8-IG	G3/8-IG
G1/2-AG	G1/2-AG
G1/2-IG	G1/2-IG

Check valves SVK, SVKG, SVV are delivered as a ready-to-connect product.



Schmalz – The Company  
Vacuum Suction Cups  
Special Grippers  
Gripping Systems  
Clamping Systems  
Mounting Elements  
Vacuum Generators  
Valve Technology  
Switches and Monitoring  
Filters and Connections  
Services  
Contact  
Glossary  
Index of Products

# Check Valves SVK, SVKG, SVV

Connection thread from M5 to G1/2"

## Ordering Data Check Valves SVK, SVKG, SVV

Type	Part no.
SVK M5-IG	10.05.03.00033
SVK G1/8-IG	10.05.03.00034
SVK G1/4-IG	10.05.03.00035
SVK G3/8-IG	10.05.03.00036
SVK G1/2-IG	10.05.03.00037
SVKG M5-AG	10.05.03.00166
SVKG G1/8-AG	10.05.03.00128
SVKG G1/4-AG	10.05.03.00131
SVKG G3/8-AG	10.05.03.00135
SVKG G1/2-AG	10.05.03.00133
SVV G1/4-IG	10.05.03.00003

## Technical Data Check Valves SVK, SVKG, SVV

Type	Evacuation rate for pu = -0,3 bar [l/min]	Evacuation rate for pu = -0,3 bar [m³/h]	Evacuation rate for pu = -0,6 bar [l/min]	Evacuation rate for pu = -0,6 bar [m³/h]	Flow rate max. [m³/h]*	Flow rate max. [l/min]**	Weight [g]
SVK M5-IG	1.2	0.08	1.3	0.08	4.8	80	2.2
SVK G1/8-IG	2.3	0.15	2.5	0.15	18.6	310	11.2
SVK G1/4-IG	2.9	0.17	3.4	0.20	20.4	340	17.5
SVK G3/8-IG	7.3	0.44	8.0	0.48	35.4	590	30.3
SVK G1/2-IG	8.1	0.49	9.0	0.54	47.4	790	47.4
SVKG M5-AG	1.2	0.08	1.3	0.08	4.8	80	2.2
SVKG G1/8-AG	2.3	0.15	2.5	0.15	18.6	310	11.2
SVKG G1/4-AG	2.9	0.17	3.4	0.21	20.4	340	17.5
SVKG G3/8-AG	7.3	0.44	8.0	0.48	35.4	590	30.3
SVKG G1/2-AG	8.1	0.49	9.0	0.54	47.4	790	47.4
SVV G1/4-IG	22.6	1.36	28.6	1.72	24.0	400	24.7

\*Blow off pressure 5 bar

\*\*Blow off pressure 5 bar

## Design Data Check Valves SVK, SVKG, SVV

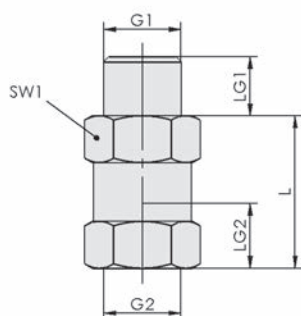

SVK

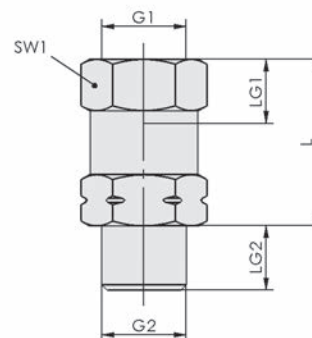

SVKG

# Check Valves SVK, SVKG, SVV

Connection thread from M5 to G1/2"



## Design Data Check Valves SVK, SVKG, SVV

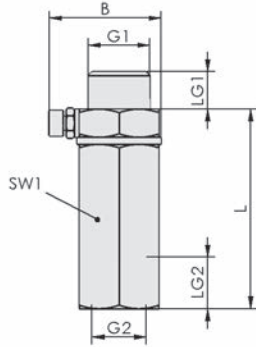

SVV

Type	B [mm]	G1	G2	L [mm]	LG1 [mm]	LG2 [mm]	SW1 [mm]
SVK M5-IG	-	M5-M	M5-F	15.5	4.5	4.5	8
SVK G1/8-IG	-	G1/8"-M	G1/8"-F	26.0	8.0	8.5	14
SVK G1/4-IG	-	G1/4"-M	G1/4"-F	26.0	10.0	11.0	17
SVK G3/8-IG	-	G3/8"-M	G3/8"-F	29.0	10.0	12.0	22
SVK G1/2-IG	-	G1/2"-M	G1/2"-F	29.0	12.0	14.0	27
SVKG M5-AG	-	M5-F	M5-M	20.0	4.5	4.5	8
SVKG G1/8-AG	-	G1/8"-F	G1/8"-M	26.0	8.5	8.0	14
SVKG G1/4-AG	-	G1/4"-F	G1/4"-M	26.0	11.0	10.0	17
SVKG G3/8-AG	-	G3/8"-F	G3/8"-M	29.0	12.0	10.0	22
SVKG G1/2-AG	-	G1/2"-F	G1/2"-M	29.0	14.0	12.0	27
SVV G1/4-IG	23.9	G1/4"-M	G1/4"-F	42.5	8.0	11.0	17



- Schmalz – The Company
- Vacuum Suction Cups
- Special Grippers
- Gripping Systems
- Clamping Systems
- Mounting Elements
- Vacuum Generators
- Valve Technology
- Switches and Monitoring
- Filters and Connections
- Services
- Contact
- Glossary
- Index of Products

# Check Valves SVN

Connection thread G1/4"



## Suitability for Industry Specific Applications

### Applications

- Check valves for handling porous workpieces
- Deactivation of unused suction cups, the system vacuum is maintained

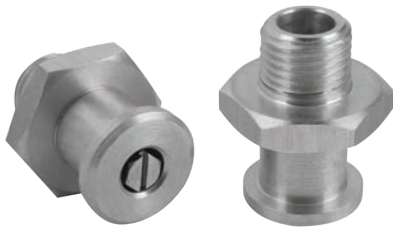

Check Valves SVN

### Design

- Flying ball valve mounted in a space saving manner in an aluminum body
- Blow off function provides self-cleaning effect for use in dusty surroundings
- Molded-on nipple for various types of suction cups (size identical to that of a standard nipple)

### Our Highlights...

- Special check valve with flying ball
- Integrated nipple for connection of a suction cup
- Check valve with self-cleaning effect

### Your Benefits...

- Reduction of the cross section of the vacuum line leading to an unused suction cup; special version for porous workpieces
- No additional nipple needed for various types of suction cups
- Special version for use in dusty surroundings



## Designation Code Check Valves SVN

<b>SVN</b>	-	<b>G1/4-AG</b>	-	<b>N011</b>
1		2		3

#### 1 - Abbreviated designation

Code	Version
SVN	SVN

#### 2 - Connection

Code	Connection
G1/4-AG M10x1.25	G1/4-AG M10x1.25
G1/4-AG	G1/4-AG (AG = male (M))

#### 3 - Nipple family

Code	Type
N009...N019	N009...N019

Check valve SVN is delivered as a ready-to-connect product.

Schmalz – The Company  
Vacuum Suction Cups  
Special Grippers  
Gripping Systems  
Clamping Systems  
Mounting Elements  
Vacuum Generators  
Valve Technology  
Switches and Monitoring  
Filters and Connections  
Services  
Contact  
Glossary  
Index of Products



# Check Valves SVN

Connection thread G1/4"

## Ordering Data Check Valves SVN

Type	Part no.
SVN G1/4-AG N011	10.05.03.00068
SVN G1/4-AG N012	10.05.03.00074
SVN G1/4-AG N013	10.05.03.00066
SVN G1/4-AG N014	10.05.03.00070
SVN G1/4-AG N015	10.05.03.00072
SVN G1/4-AG N018	10.05.03.00054
SVN G1/4-AG N019	10.05.03.00056
SVN G1/4-AG M10x1.25-AG N009	10.05.03.00060

## Technical Data Check Valves SVN

Type	Evacuation rate for pu = -0,3 bar [m³/h]	Evacuation rate for pu = -0,3 bar [l/min]	Evacuation rate for pu = -0,6 bar [m³/h]	Evacuation rate for pu = -0,6 bar [l/min]	Flow rate max. [m³/h]*	Flow rate max. [l/min]**	Weight [g]
SVN G1/4-AG N011	2.3	38.3	3.3	55	27	450	8
SVN G1/4-AG N012	2.3	38.3	3.3	55	27	450	15
SVN G1/4-AG N013	2.3	38.3	3.3	55	27	450	9
SVN G1/4-AG N014	2.3	38.3	3.3	55	27	450	12
SVN G1/4-AG N015	2.3	38.3	3.3	55	27	450	18
SVN G1/4-AG N018	2.3	38.3	3.3	55	27	450	8
SVN G1/4-AG N019	2.3	38.3	3.3	55	27	450	18
SVN G1/4-AG M10x1.25-AG N009	2.3	38.3	3.3	55	27	450	10

\*Blow off pressure 5 bar  
\*\*Blow off pressure 5 bar

## Design Data Check Valves SVN

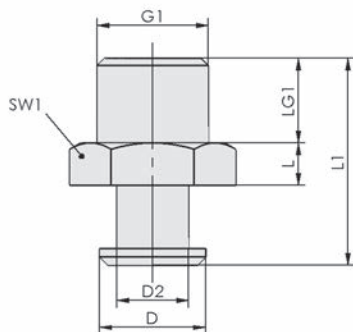

SVN N011 - N019

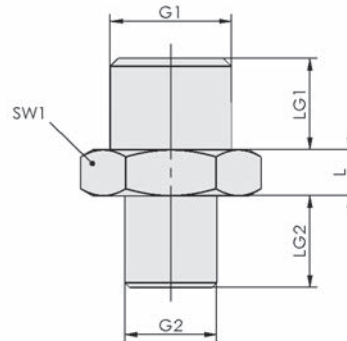

SVN N009

# Check Valves SVN

Connection thread G1/4"



## Design Data Check Valves SVN

Type	D [mm]	D2 [mm]	G1	G2	L [mm]	LG1 [mm]	LG2 [mm]	L1 [mm]	SW1 [mm]
SVN G1/4-AG N011	12.5	8.5	G1/4"-M	-	5	10	-	25.0	17
SVN G1/4-AG N012	18.0	13.0	G1/4"-M	-	5	10	-	29.5	22
SVN G1/4-AG N013	12.5	8.5	G1/4"-M	-	5	10	-	28.5	17
SVN G1/4-AG N014	16.5	12.5	G1/4"-M	-	5	10	-	29.5	17
SVN G1/4-AG N015	16.5	13.0	G1/4"-M	-	5	10	-	37.5	22
SVN G1/4-AG N018	14.0	9.0	G1/4"-M	-	5	11	-	29.0	17
SVN G1/4-AG N019	20.0	13.5	G1/4"-M	-	6	11	-	40.0	21
SVN G1/4-AG M10x1.25-AG N009	-	-	G1/4"-M	M10x1.25-M	5	10	10	-	17

Schmalz –  
The Company

Vacuum  
Suction Cups

Special  
Grippers

Gripping  
Systems

Clamping  
Systems

Mounting  
Elements

Vacuum  
Generators

Valve  
Technology

Switches and  
Monitoring

Filters and  
Connections

Services

Contact

Glossary

Index of  
Products



# Flow Restrictors SW

Nominal diameter from 0.25 mm to 2 mm



## Suitability for Industry Specific Applications

### Applications

- Flow resistor for handling of porous workpieces
- Reduction of the flow rate through individual suction cups in order to maintain the vacuum in the overall system
- May be installed in any orientation



Flow Restrictors SW

### Design

- Double ended threaded nipple with reduced flow cross section
- Large gradation of different flow cross sections

### Our Highlights...

- No moving parts
- Acts as a flow resistor with a reduced cross section
- Minimum size

### Your Benefits...

- Robust design with long operating lifetime
- Reduction of the cross section of the vacuum line, particularly useful when handling porous workpieces
- Also suitable for use in restricted spaces



### Designation Code Flow Restrictors SW

<b>SW</b>	-	<b>25</b>	-	<b>G1/8-AG</b>
1		2		3

**1** – Abbreviated designation

Code	Version
SW	SW

**2** – Nozzle size

Code	Nozzle size in mm
25...200	0.25 to 2

**3** – Connection

Code	Connection
G1/8-AG	G1/8-AG (AG = male (M))
G1/4-AG	G1/4-AG

Flow resistor SW is delivered as a ready-to-connect product.

Schmalz – The Company  
Vacuum Suction Cups  
Special Grippers  
Gripping Systems  
Clamping Systems  
Mounting Elements  
Vacuum Generators  
Valve Technology  
Switches and Monitoring  
Filters and Connections  
Services  
Contact  
Glossary  
Index of Products



# Flow Restrictors SW

Nominal diameter from 0.25 mm to 2 mm



## Ordering Data Flow Restrictors SW

Type	G1/8-AG	G1/4-AG
SW 25	10.05.04.00034	-
SW 40	10.05.04.00001	10.05.04.00010
SW 50	10.05.04.00002	10.05.04.00011
SW 60	10.05.04.00003	10.05.04.00012
SW 70	10.05.04.00004	10.05.04.00013
SW 80	10.05.04.00005	10.05.04.00014
SW 90	10.05.04.00006	10.05.04.00015
SW 100	10.05.04.00007	10.05.04.00016
SW 110	10.05.04.00008	10.05.04.00017
SW 120	10.05.04.00009	10.05.04.00018
SW 150	-	10.05.04.00029
SW 200	-	10.05.04.00019



## Technical Data Flow Restrictors SW

Type	Evacuation rate for pu = -0,3 bar [m³/h]	Evacuation rate for pu = -0,3 bar [l/min]	Evacuation rate for pu = -0,6 bar [m³/h]	Evacuation rate for pu = -0,6 bar [l/min]
SW 25	0.01	0.2	0.02	0.3
SW 40	0.06	1.0	0.08	1.3
SW 50	0.13	2.2	0.15	2.5
SW 60	0.18	3.0	0.19	3.1
SW 70	0.24	4.0	0.26	4.3
SW 80	0.30	4.9	0.32	5.3
SW 90	0.39	6.5	0.42	7.0
SW 100	0.47	7.8	0.50	8.4
SW 110	0.62	10.3	0.63	10.5
SW 120	0.74	12.3	0.76	12.7
SW 150	1.32	22.0	1.40	23.4
SW 200	2.05	34.1	2.19	36.4



## Design Data Flow Restrictors SW

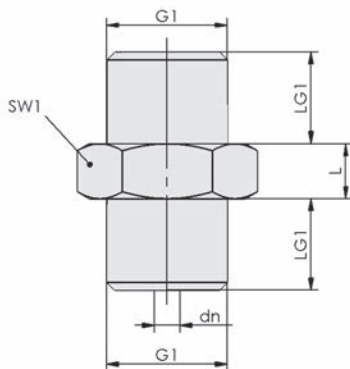

SW



# Flow Restrictors SW

Nominal diameter from 0.25 mm to 2 mm



## Design Data Flow Restrictors SW

Type	dn [mm]	G1	L [mm]	LG1 [mm]	SW1 [mm]
SW 25 G1/8-AG	0.25	G1/8"-M	6	9.5	14
SW 40 G1/8-AG	0.40	G1/8"-M	6	9.5	14
SW 50 G1/8-AG	0.50	G1/8"-M	6	9.5	14
SW 60 G1/8-AG	0.60	G1/8"-M	6	9.5	14
SW 70 G1/8-AG	0.70	G1/8"-M	6	9.5	14
SW 80 G1/8-AG	0.80	G1/8"-M	6	9.5	14
SW 90 G1/8-AG	0.90	G1/8"-M	6	9.5	14
SW 100 G1/8-AG	1.00	G1/8"-M	6	9.5	14
SW 110 G1/8-AG	1.11	G1/8"-M	6	9.5	14
SW 120 G1/8-AG	1.20	G1/8"-M	6	9.5	14
SW 40 G1/4-AG	0.40	G1/4"-M	6	10.0	17
SW 50 G1/4-AG	0.50	G1/4"-M	6	10.0	17
SW 60 G1/4-AG	0.60	G1/4"-M	6	10.0	17
SW 70 G1/4-AG	0.70	G1/4"-M	6	10.0	17
SW 80 G1/4-AG	0.80	G1/4"-M	6	10.0	17
SW 90 G1/4-AG	0.90	G1/4"-M	6	10.0	17
SW 100 G1/4-AG	1.00	G1/4"-M	6	10.0	17
SW 110 G1/4-AG	1.11	G1/4"-M	6	10.0	17
SW 120 G1/4-AG	1.20	G1/4"-M	6	10.0	17
SW 150 G1/4-AG	1.50	G1/4"-M	5	9.0	17
SW 200 G1/4-AG	2.00	G1/4"-M	5	9.0	17

- Schmalz – The Company
- Vacuum Suction Cups
- Special Grippers
- Gripping Systems
- Clamping Systems
- Mounting Elements
- Vacuum Generators
- Valve Technology
- Switches and Monitoring
- Filters and Connections
- Services
- Contact
- Glossary
- Index of Products



# Touch Valves TV / TVN

Flow rate from 12 l/min to 160 l/min



## Suitability for Industry Specific Applications

### Applications

- Touch valve for applications where some of the suction cups may not always be in contact with the workpiece
- Vacuum line to a suction cup is opened only if a workpiece is detected by a mechanical sensor
- May be installed in any orientation



Touch Valves TV / TVN

### Design

- Touch valve with spring loaded plunger and protective cap
- Type TVN with molded-on suction cup nipple for direct mounting
- Does not react if the suction cup is only partially in contact with the workpiece

### Our Highlights...

- Touch valve with spring loaded plunger
- Reaction is unaffected by the workpiece material
- Minimum size

### Your Benefits...

- The vacuum line is opened only if the suction cup is in contact with the workpiece (mechanical sensing)
- Can also be used for porous workpieces
- Also suitable for use in restricted spaces



## Designation Code Touch Valves TV / TVN

<b>TV</b>	-	<b>G1/4-AG</b>	-	<b>9</b>	-	<b>N009</b>
1		2		3		4

#### 1 – Abbreviated designation

Code	Version
TV	Without suction cup nipple
TVN	With suction cup nipple

#### 2 – Connection

Code	Connection
G1/8-AG	G1/8-AG (AG = male (M))
G1/4-AG	G1/4-AG
G1/2-AG	G1/2-AG

#### 3 – Plunger stroke

Code	Stroke in mm
5...13	5 to 13

#### 4 – Nipple family

Code	Type
N007...	N007 to N009 and N041
N009, N041	

Touch valve TV / TVN is delivered as a ready-to-connect product.

Schmalz – The Company  
Vacuum Suction Cups  
Special Grippers  
Gripping Systems  
Clamping Systems  
Mounting Elements  
Vacuum Generators  
Valve Technology  
Switches and Monitoring  
Filters and Connections  
Services  
Contact  
Glossary  
Index of Products



# Touch Valves TV / TVN

Flow rate from 12 l/min to 160 l/min

- Schmalz - The Company
- Vacuum Suction Cups
- Special Grippers
- Gripping Systems
- Clamping Systems
- Mounting Elements
- Vacuum Generators
- Valve Technology
- Switches and Monitoring
- Filters and Connections
- Services
- Contact
- Glossary
- Index of Products



## Ordering Data Touch Valves TV / TVN

Type	Part no.
TV G1/4-AG 5	10.05.10.00064
TV G1/4-AG 13	10.05.10.00061
TV G1/2-AG 13	10.05.10.00038
TVN G1/8-AG 6 N007	10.05.10.00021
TVN G1/8-AG 6.5 N008	10.05.10.00023
TVN G1/4-AG 8.4 N041	10.05.10.00058
TVN G1/4-AG 9 N009	10.05.10.00065



## Technical Data Touch Valves TV / TVN

Type	Nominal flow rate [l/min]	Nominal flow rate [m³/h]
TV G1/4-AG 5	55	3.3
TV G1/4-AG 13	55	3.3
TV G1/2-AG 13	160	9.6
TVN G1/8-AG 6 N007	12	0.7
TVN G1/8-AG 6.5 N008	12	0.7
TVN G1/4-AG 8.4 N041	78	4.6
TVN G1/4-AG 9 N009	78	4.6



## Design Data Touch Valves TV / TVN

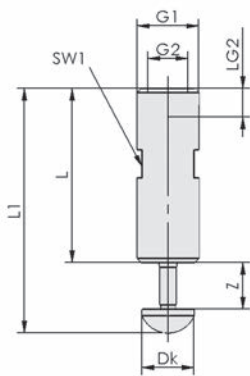

TV

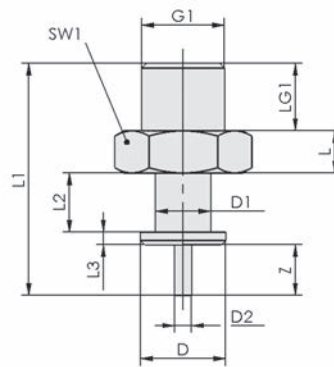

TVN 6 - 8.4



# Touch Valves TV / TVN

Flow rate from 12 l/min to 160 l/min



## Design Data Touch Valves TV / TVN

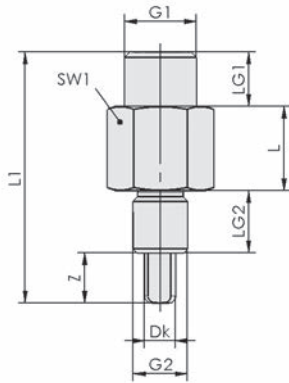

TVN 9

Type	D [mm]	D1 [mm]	D2 [mm]	Dk [mm]	G1	G2	L [mm]	L1 [mm]	L2 [mm]	L3 [mm]	LG1 [mm]	LG2 [mm]	SW1 [mm]	Z (Stroke) [mm]
TV G1/4-AG 5	-	-	-	11	G1/4"-M	G1/8"-F	45.5	55.7	-	-	-	6	11	5.0
TV G1/4-AG 13	-	-	-	11	G1/4"-M	G1/8"-F	45.5	63.1	-	-	-	6	11	13.0
TV G1/2-AG 13	-	-	-	11	G1/2"-M	G3/8"-F	54.5	67.5	-	-	-	12	19	13.0
TVN G1/8-AG 6 N007	10	6.5	2.0	-	G1/8"-M	-	5.0	27.5	7.0	1.5	8	-	14	6.0
TVN G1/8-AG 6.5 N008	14	8.5	2.0	-	G1/8"-M	-	5.0	28.5	7.0	1.5	8	-	14	6.5
TVN G1/4-AG 8.4 N041	17	8.7	6.0	-	G1/4"-M	-	10.0	45.7	12.3	3.0	11	-	17	8.4
TVN G1/4-AG 9 N009	-	-	-	6	G1/4"-M	M10x1.25-M	15.5	47.0	-	-	10	12	17	9.0

- Schmalz – The Company
- Vacuum Suction Cups
- Special Grippers
- Gripping Systems
- Clamping Systems
- Mounting Elements
- Vacuum Generators
- Valve Technology
- Switches and Monitoring
- Filters and Connections
- Services
- Contact
- Glossary
- Index of Products



# Non-Return Valves RSV

Nominal diameter from 6 mm to 54 mm



## Suitability for Industry Specific Applications

### Applications

- Non-return valve for maintaining the vacuum in the case of a power failure or a failure of the vacuum generator
- Can also be used with energy saving systems when handling non-porous materials
- May be installed in any orientation

Non-Return Valves RSV

### Design

- Spring loaded seat valve
- Brass body (RSV 6, which is made of aluminum)
- Seat made of synthetic rubber, gasket made of nylon
- Stainless steel spring

### Our Highlights...

- Seat type non-return valve
- Wide range of nominal diameters
- Very small size

### Your Benefits...

- Closure of the vacuum line in order to maintain the system vacuum in the case, for example, of a power failure
- Very low to very high nominal flow rates possible
- Also suitable for use in restricted spaces



## Designation Code Non-Return Valves RSV

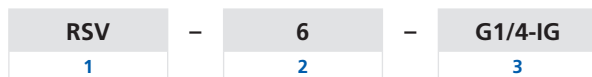

#### 1 - Abbreviated designation

Code	Version
RSV	RSV

#### 2 - Nozzle size

Code	Nozzle size in mm
6...54	6 to 54

#### 3 - Connection

Code	Connection
G1/4-IG	G1/4-IG (IG = female (F))
G3/8-IG	G3/8-IG
G1/2-IG	G1/2-IG
G3/4-IG	G3/4-IG
G1-IG	G1-IG
G1-1/4-IG	G1-1/4-IG
G1-1/2-IG	G1-1/2-IG
G2-IG	G2-IG

Non-return valve RSV is delivered as a ready-to-connect product.



Schmalz - The Company  
Vacuum Suction Cups  
Special Grippers  
Gripping Systems  
Clamping Systems  
Mounting Elements  
Vacuum Generators  
Valve Technology  
Switches and Monitoring  
Filters and Connections  
Services  
Contact  
Glossary  
Index of Products

# Non-Return Valves RSV

Nominal diameter from 6 mm to 54 mm



## Ordering Data Non-Return Valves RSV

Type	Part no.
RSV 6 G1/4-IG	10.05.05.00116
RSV 14 G3/8-IG	10.05.05.00002
RSV 18 G1/2-IG	10.05.05.00003
RSV 20 G3/4-IG	10.05.05.00004
RSV 28 G1-IG	10.05.05.00005
RSV 36 G1-1/4-IG	10.05.05.00006
RSV 42 G1-1/2-IG	10.05.05.00007
RSV 54 G2-IG	10.05.05.00008



## Technical Data Non-Return Valves RSV

Type	Nominal size [mm]	Nominal flow rate [m³/h]	Nominal flow rate [l/min]	Opening pressure [mbar]	Operating temperature [°C]	Weight [kg]
RSV 6 G1/4-IG	6	5	84	200	-10 ... 70	0.04
RSV 14 G3/8-IG	14	20	334	20	-20 ... 100	0.18
RSV 18 G1/2-IG	18	26	434	20	-20 ... 100	0.19
RSV 20 G3/4-IG	20	45	750	20	-20 ... 100	0.27
RSV 28 G1-IG	28	75	1,250	20	-20 ... 100	0.49
RSV 36 G1-1/4-IG	36	125	2,084	20	-20 ... 100	0.74
RSV 42 G1-1/2-IG	42	200	3,334	20	-20 ... 100	0.98
RSV 54 G2-IG	54	350	5,834	20	-20 ... 100	1.11



## Design Data Non-Return Valves RSV

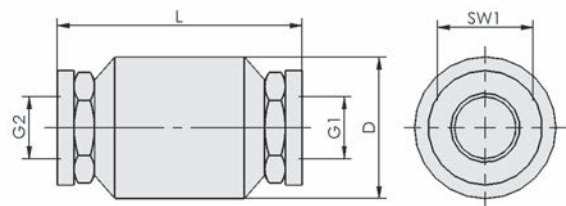
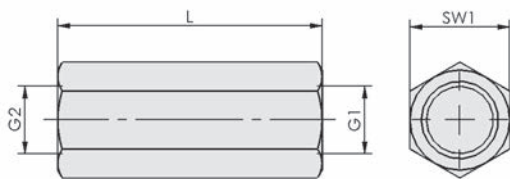

RSV 6

RSV 14 - 54

Type	D [mm]	G1	G2	L [mm]	SW1 [mm]
RSV 6 G1/4-IG	-	G1/4"-F	G1/4"-F	43	16
RSV 14 G3/8-IG	34	G3/8"-F	G3/8"-F	59	23
RSV 18 G1/2-IG	34	G1/2"-F	G1/2"-F	62	27
RSV 20 G3/4-IG	41	G3/4"-F	G3/4"-F	69	33
RSV 28 G1-IG	52	G1"-F	G1"-F	84	40
RSV 36 G1-1/4-IG	63	G1-1/4"-F	G1-1/4"-F	88	50
RSV 42 G1-1/2-IG	71	G1-1/2"-F	G1-1/2"-F	96	50
RSV 54 G2-IG	87	G2"-F	G2"-F	100	70



Schmalz – The Company  
Vacuum Suction Cups  
Special Grippers  
Gripping Systems  
Clamping Systems  
Mounting Elements  
Vacuum Generators  
Valve Technology  
Switches and Monitoring  
Filters and Connections  
Services  
Contact  
Glossary  
Index of Products

# Two-Way Ball Valves KVZ

Nominal diameter from 8 mm to 50 mm



## Suitability for Industry Specific Applications

### Applications

- Two-way ball valve for manual connection and disconnection of vacuum and compressed air circuits
- For use in vacuum spiders and handling devices
- May be installed in any orientation



Two-Way Ball Valves KVZ

### Design

- Ball valve made of brass (body and ball)
- Teflon gaskets
- 2/2-way valve

### Our Highlights...

- For use with vacuum and compressed air
- Wide range of nominal sizes
- Robust brass construction

### Your Benefits...

- Absolutely tight: no leaks
- Optimum matching to nominal flow rate
- Robust and free of wear

## Designation Code Two-Way Ball Valves KVZ



**1** – Abbreviated designation

Code	Version
KVZ	KVZ

**2** – Nozzle size

Code	Nozzle size in mm
8...50	8 to 50

**3** – Variant

Code	Type
2/2	2/2-way valve

Two-way ball valve KVZ is delivered as a ready-to-connect product.

Schmalz – The Company  
Vacuum Suction Cups  
Special Grippers  
Gripping Systems  
Clamping Systems  
Mounting Elements  
Vacuum Generators  
Valve Technology  
Switches and Monitoring  
Filters and Connections  
Services  
Contact  
Glossary  
Index of Products



# Two-Way Ball Valves KVZ

Nominal diameter from 8 mm to 50 mm



## Ordering Data Two-Way Ball Valves KVZ

Type	Part no.
KVZ 8 2/2	10.05.08.00018
KVZ 20 2/2	10.05.08.00007
KVZ 32 2/2	10.05.08.00008
KVZ 50 2/2	10.05.08.00009



## Technical Data Two-Way Ball Valves KVZ

Type	Nominal size [mm]	Nominal flow rate [m³/h]	Nominal flow rate [l/min]	Pressure range (operating pressure) [bar]	Weight [kg]
KVZ 8 2/2	8	10	168	-0.95 ... 15.00	0.077
KVZ 20 2/2	20	45	750	-0.95 ... 15.00	0.280
KVZ 32 2/2	32	100	1,667	-0.95 ... 15.00	0.700
KVZ 50 2/2	50	310	5,167	-0.95 ... 15.00	1.470



## Design Data Two-Way Ball Valves KVZ

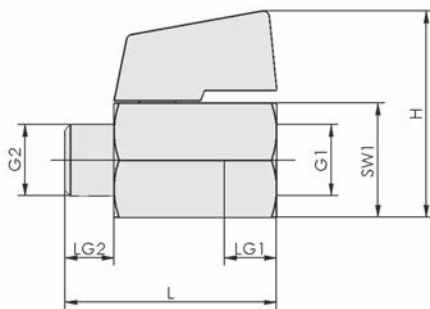

KVZ 8

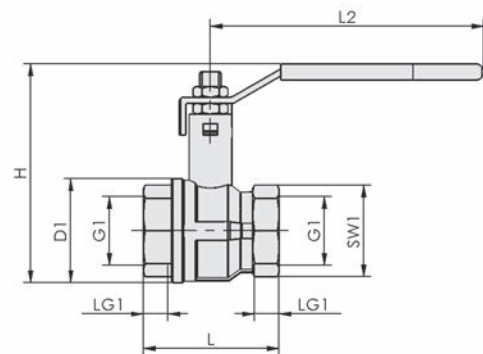

KVZ 20 - 50

Type	D1 [mm]	G1	G2	H [mm]	L [mm]	L2 [mm]	LG1 [mm]	LG2 [mm]	SW1 [mm]
KVZ 8 2/2	-	G1/4"-F	G1/4"-M	38	39	-	11	9	21
KVZ 20 2/2	39	G3/4"-F	-	70	54	120	12	-	31
KVZ 32 2/2	59	G1-1/4"-F	-	125	77	155	16	-	48
KVZ 50 2/2	86	G2"-F	-	151	106	155	20	-	66



# Three-Way Ball Valves KVD

Nominal diameter from 6 mm to 25 mm

- Schmalz – The Company
- Vacuum Suction Cups
- Special Grippers
- Gripping Systems
- Clamping Systems
- Mounting Elements
- Vacuum Generators
- Valve Technology
- Switches and Monitoring
- Filters and Connections
- Services
- Contact
- Glossary
- Index of Products



## Suitability for Industry Specific Applications



### Applications

- Three-way ball valve for manual connection and disconnection of vacuum and compressed air circuits
- Activation and venting of individual suction cups
- For use in vacuum spiders and handling devices
- May be installed in any orientation

Three-Way Ball Valves KVD

### Design

- Ball valve made of brass (body and ball)
- Teflon gaskets
- Aluminum handle
- 3/2-way valve

### Our Highlights...

- For use with vacuum and compressed air
- Wide range of nominal sizes
- Robust brass construction
- Venting function

### Your Benefits...

- Absolutely tight: no leaks
- Optimal matching to the nominal flow rate
- Robust and free of wear
- Quick release of parts

## Designation Code Three-Way Ball Valves KVD

<b>KVD</b>	–	<b>6</b>	–	<b>3/2</b>
1		2		3

**1** – Abbreviated designation

**2** – Nozzle size

**3** – Variant

Code	Version
KVD	KVD

Code	Nozzle size in mm
6...25	6 to 25

Code	Type
3/2	3/2-way valve

Three-way ball valve KVD is delivered as a ready-to-connect product.

## Ordering Data Three-Way Ball Valves KVD

Type	Part no.
KVD 6 3/2	10.05.08.00001
KVD 10 3/2	10.05.08.00002
KVD 15 3/2	10.05.08.00003
KVD 20 3/2	10.05.08.00004
KVD 25 3/2	10.05.08.00005

# Three-Way Ball Valves KVD

Nominal diameter from 6 mm to 25 mm



## Technical Data Three-Way Ball Valves KVD

Type	Nominal size [mm]	Nominal flow rate [m³/h]*	Nominal flow rate [l/min]	Pressure range (operating pressure) [bar]	Weight [kg]
KVD 6 3/2	6	5	84	-0.95 ... 16.00	0.081
KVD 10 3/2	10	15	250	-0.95 ... 16.00	0.810
KVD 15 3/2	15	22	367	-0.95 ... 16.00	0.810
KVD 20 3/2	20	45	750	-0.95 ... 16.00	1.260
KVD 25 3/2	25	55	917	-0.95 ... 16.00	1.930

\*In the case of a pressure drop of 50 mbar



## Design Data Three-Way Ball Valves KVD

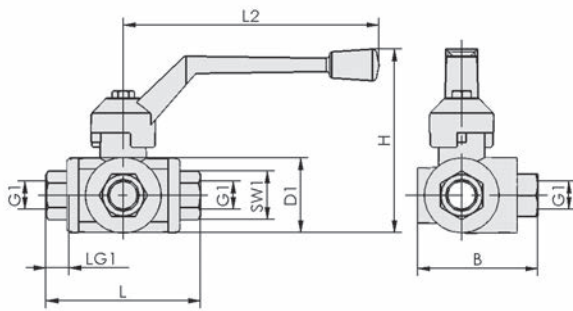

KVD

Type	B [mm]	D1 [mm]	G1	H [mm]	L [mm]	L2 [mm]	LG1 [mm]	SW1 [mm]
KVD 6 3/2	58	39	G1/4"-F	85	77	125	19	22
KVD 15 3/2	58	39	G1/2"-F	85	77	125	19	29
KVD 10 3/2	58	39	G3/8"-F	85	77	125	19	22
KVD 25 3/2	80	55	G1"-F	124	104	170	25	41
KVD 20 3/2	70	47	G3/4"-F	107	92	145	23	34

# Manual Slide Valves HSV

Nominal diameter from 7 mm to 24 mm



## Suitability for Industry Specific Applications

### Applications

- Vacuum valve for manual switching of vacuum or compressed air circuits
- Robust construction permits high switching frequencies
- For use in vacuum gripping systems and handling devices
- May be installed in any orientation



Manual Slide Valves HSV

### Design

- Manual slide valve made of brass and aluminum
- Additional lock possible (HSV 12 and 24 3/2 S)
- Easily actuated sliding sleeve
- 3/2-way valve

### Our Highlights...

- For use with vacuum and compressed air
- Wide range of nominal sizes
- Robust metal construction
- Small size
- Venting function

### Your Benefits...

- Absolutely vacuum tight: no leaks
- Optimum matching to the nominal flow rate
- Robust and free of wear
- Space saving and ergonomical
- Venting function for quick release of parts



### Designation Code Manual Slide Valves HSV



#### 1 - Abbreviated designation

Code	Version
HSV	HSV

#### 2 - Nozzle size

Code	Nozzle size in mm
7...24	7 to 24

#### 3 - Variant

Code	Type
3/2	3/2-way valve

#### 4 - Product addition

Code	Type
S	Lock

Manual slide valve HSV is delivered as a ready-to-connect product.



Schmalz - The Company  
Vacuum Suction Cups  
Special Grippers  
Gripping Systems  
Clamping Systems  
Mounting Elements  
Vacuum Generators  
Valve Technology  
Switches and Monitoring  
Filters and Connections  
Services  
Contact  
Glossary  
Index of Products

# Manual Slide Valves HSV

Nominal diameter from 7 mm to 24 mm



## Ordering Data Manual Slide Valves HSV

Type	Part no.
HSV 7 3/2	10.05.07.00034
HSV 8 3/2	10.05.07.00035
HSV 12 3/2	10.05.07.00036
HSV 12 3/2 S	10.05.07.00037
HSV 24 3/2 S	10.05.07.00038



## Technical Data Manual Slide Valves HSV

Type	Nominal size [mm]	Nominal flow rate [m³/h]	Nominal flow rate [l/min]	Pressure range (operating pressure) [bar]	Weight [kg]
HSV 7 3/2	7	6	100	-0.95 ... 10.00	0.097
HSV 8 3/2	8	10	167	-0.95 ... 10.00	0.156
HSV 12 3/2	12	16	267	-0.95 ... 10.00	0.230
HSV 12 3/2 S	12	16	267	-0.95 ... 10.00	0.356
HSV 24 3/2 S	24	50	834	-0.95 ... 10.00	0.513



## Design Data Manual Slide Valves HSV

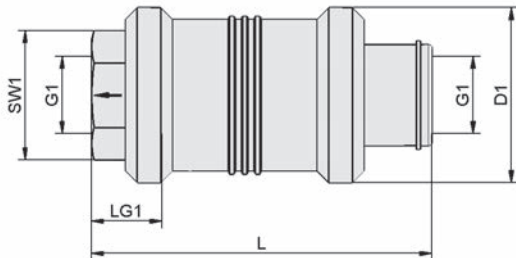

HSV

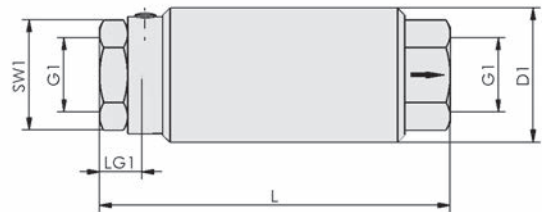

HSV S

Type	D1 [mm]	G1	L [mm]	LG1 [mm]	SW1 [mm]
HSV 7 3/2	30	G1/4"-F	58.0	12	19
HSV 8 3/2	35	G3/8"-F	70.7	15	22
HSV 12 3/2	40	G1/2"-F	80.0	16	27
HSV 12 3/2 S	38	G1/2"-F	99.5	15	27
HSV 24 3/2 S	45	G3/4"-F	110.0	16	32

# Switches and System Monitoring

- Schmalz – The Company
- Vacuum Suction Cups
- Special Grippers
- Gripping Systems
- Clamping Systems
- Mounting Elements
- Vacuum Generators
- Valve Technology
- Switches and Monitoring**
- Filters and Connections
- Services
- Contact
- Glossary
- Index of Products



Selection Aid		Page	
	<b>Checklist for Selection of Measuring and Control Devices</b>	601	Schmalz – The Company Vacuum Suction Cups Special Grippers Gripping Systems Clamping Systems
<b>Mechanic Vacuum Switches</b>			
	<b>Vacuum Switches VS-V-PM/EM-ST</b> <ul style="list-style-type: none"> <li>• Vacuum switch in electro-mechanical and pneumatical version</li> <li>• Measuring range: from -1 to 0 bar</li> </ul>	602	Mounting Elements Vacuum Generators
			Mechanical vacuum switch in electrical and pneumatic version with adjustable switching point.
<b>Vacuum and Pressure Sensors</b>			
	<b>Vacuum Sensor VS-V-SA</b> <ul style="list-style-type: none"> <li>• Miniature electronic vacuum sensor</li> <li>• Measuring range: from -1 to 0 bar</li> </ul>	605	Valve Technology Switches and Monitoring
			Vacuum sensor in minimum design with analog switching output.
	<b>Vacuum and Pressure Sensors VS</b> <ul style="list-style-type: none"> <li>• Vacuum and pressure sensor with analog output signal</li> <li>• Measuring range: -1 to 10 bar</li> </ul>	609	Filters and Connections Services
			Electronic sensor for constant and precise measurement of vacuum and overpressure; display of data on smartphone using NFC technology.
<b>Electronic Vacuum and Pressure Switches</b>			
	<b>Vacuum and Pressure Switches VSi</b> <ul style="list-style-type: none"> <li>• Electronic vacuum and pressure switch</li> <li>• Measuring range: -1 to 10 bar</li> <li>• Switching function: PNP, NPN</li> </ul>	611	Contact Glossary
			Electronic vacuum and pressure switch with IO-Link interface for measuring, monitoring vacuum and overpressure in automation systems.

Schmalz – The Company  
 Vacuum Suction Cups  
 Special Grippers  
 Gripping Systems  
 Clamping Systems  
 Mounting Elements  
 Vacuum Generators  
 Valve Technology  
 Switches and Monitoring  
 Filters and Connections  
 Services  
 Contact  
 Glossary  
 Index of Products

At a Glance

Schmalz – The Company  
 Vacuum Suction Cups  
 Special Grippers  
 Gripping Systems  
 Clamping Systems  
 Mounting Elements  
 Vacuum Generators  
 Valve Technology  
 Switches and Monitoring  
 Filters and Connections  
 Services  
 Contact  
 Glossary  
 Index of Products

		Page
	<b>Vacuum and Pressure Switches VS-V/P-W-D-K(-2C)</b> <ul style="list-style-type: none"> <li>• Electronic vacuum and pressure switch</li> <li>• Measuring range: from -1 to 10 bar</li> <li>• Switching function: PNP, NPN</li> </ul>	 Vacuum and pressure switch with two separately programmable digital outputs, digital display, adjustable switching point and hysteresis. 614
	<b>Vacuum Switches VS-V-SD</b> <ul style="list-style-type: none"> <li>• Miniature electronic vacuum switch</li> <li>• Measuring range: from -1 to 0 bar</li> </ul>	 Vacuum switch in minimum design with digital switching output. 618
	<b>Vacuum and Pressure Switches VS-V/P-AH/AV-T</b> <ul style="list-style-type: none"> <li>• Electronic vacuum and pressure switch</li> <li>• Measuring range: from -1 to 10 bar</li> <li>• Switching function: PNP</li> </ul>	 Vacuum and pressure switch with two digital switching outputs, teach button for fast adjustment of the switching point and two-color LED indicator. 620
<b>Measuring and Control Devices</b>		
	<b>Vacuum Regulators VR</b> <ul style="list-style-type: none"> <li>• Adjustment range: from -990 to -14 mbar</li> </ul>	 Mechanically adjustable vacuum controller with very high accuracy to compensate for design-related pressure fluctuations. 624
	<b>Manometers VAM</b> <ul style="list-style-type: none"> <li>• Measuring range: from -1 to 0 bar</li> </ul>	 Manometer with different scales for analog measurement and monitoring of the vacuum value. 626
	<b>Manometer VAM-D</b> <ul style="list-style-type: none"> <li>• Electronic manometer</li> <li>• Measuring range: from -1 to 10 bar</li> </ul>	 Electronic manometer with digital display for use in vacuum and pressure systems for recording and displaying of vacuum and pressure. 629
	<b>Pressure-Reduction Valves DM</b> <ul style="list-style-type: none"> <li>• Max. pressure: 10 bar</li> <li>• Work area: from 0.5 to 10 bar</li> </ul>	 Mechanically adjustable pressure reducer for regulation of compressed air in compressed air systems. 631



## Checklist for Selection of Measuring and Control Devices

<p><b>Which measuring range is required?</b></p>	<ul style="list-style-type: none"> <li>• Vacuum only?</li> <li>• Pressure only?</li> <li>• Vacuum and Pressure?</li> <li>• Is overpressure resistance necessary?</li> </ul>
<p><b>Which functions are needed?</b></p>	<ul style="list-style-type: none"> <li>• Switch with one digital output?</li> <li>• Switch with two digital outputs?</li> <li>• Switch with one digital and one analog output?</li> <li>• With adjustable hysteresis?</li> </ul>
<p><b>Which output signals are required?</b> <b>How should the switch be set?</b></p>	<ul style="list-style-type: none"> <li>• Adjustment with potentiometer?</li> <li>• Programming with keypad?</li> <li>• Programming via IO-Link?</li> <li>• Quick setting with teach button?</li> <li>• Programming and readout via NFC directly on the smartphone or tablet?</li> </ul>
<p><b>What is the supply voltage and which signal voltages are needed?</b></p>	<ul style="list-style-type: none"> <li>• Voltage range? Switching voltages for the controller?</li> <li>• Which switching capacity is needed (switched current in mA)?</li> </ul>
<p><b>Which measuring accuracy is necessary?</b></p>	<ul style="list-style-type: none"> <li>• Hysteresis?</li> <li>• Repeatability?</li> <li>• Temperature stability?</li> </ul>
<p><b>Which connection facilities exist?</b></p>	<ul style="list-style-type: none"> <li>• Connection cable (pin assignments, material)?</li> <li>• Interchangeability?</li> </ul>
<p><b>Which size and weight restrictions apply?</b></p>	<ul style="list-style-type: none"> <li>• Mounting facilities?</li> <li>• Is on-site adjustment possible?</li> </ul>

Schmalz –  
The Company

Vacuum  
Suction Cups

Special  
Grippers

Gripping  
Systems

Clamping  
Systems

Mounting  
Elements

Vacuum  
Generators

Valve  
Technology

Switches and  
Monitoring

Filters and  
Connections

Services

Contact

Glossary

Index of  
Products

# Vacuum Switches VS-V-PM/EM-ST

Measuring range from -1 bar to 0 bar



## Suitability for Industry Specific Applications

### Applications

- Mechanical vacuum switch for process monitoring
- Optimization of cycle times or regulation circuits
- Application in processes where an electric or pneumatic signal related to a defined vacuum value is required
- Can be used as a measuring and switching element



Vacuum Switches VS-V-PM/EM-ST

### Design

- Vacuum switch in electro-mechanical (EM) and pneumatic (PM) version
- VS-V-EM-ST with one digital switching output in NO/NC version
- VS-V-PM with pneumatic output in NO or alternatively NC version
- Robust and hard-wearing plastic housing
- Optional for EM Version: cover (1) for IP-protection and strain relief of the connection cable or cover (2) for IP-protection and mounted M8 4-pin plug
- 2 m cable (3) with M8 plug, 4-pin (optional for EM version)

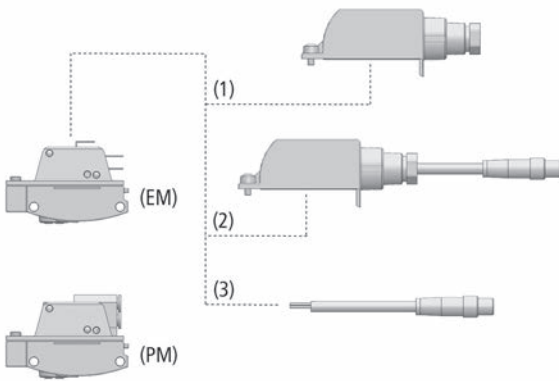

System Design Vacuum Switches VS-V-PM/EM-ST

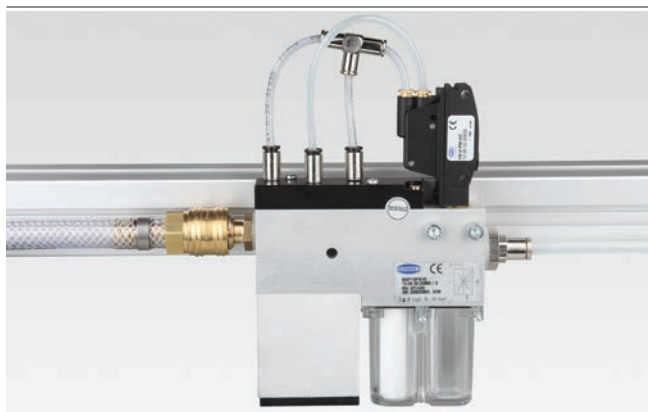

Mounting example vacuum switch VS-V-PM

### Our Highlights...

- Robust plastic housing
- Electro-mechanical version
- Pneumatically version
- Adjustable switching point

### Your Benefits...

- Solid construction, precise operation
- Switching of DC and AC with one version
- No electric connections required, pure pneumatic operation
- Individually adaptable to process parameter

- Schmalz – The Company
- Vacuum Suction Cups
- Special Grippers
- Gripping Systems
- Clamping Systems
- Mounting Elements
- Vacuum Generators
- Valve Technology
- Switches and Monitoring
- Filters and Connections
- Services
- Contact
- Glossary
- Index of Products



# Vacuum Switches VS-V-PM/EM-ST

Measuring range from -1 bar to 0 bar

## Designation Code Vacuum Switches VS-V-PM/EM-ST



### 1 – Abbreviated designation

Code	Version
VS	VS

### 2 – Measuring range

Code	Measuring range in bar
V	-1 to 0

### 3 – Variant

Code	Type
EM	Electromechanical
PM	Pneumatical

### 4 – Connection electrical

Code	Connection
NC	Normally closed
NO	Normally open
ST	Contact of flat-pin plug (for EM version)

Vacuum switch VS-V-PM/EM-ST is delivered as a ready-to-connect product (without connection cable).

Available accessories: cover, connection cable

## Ordering Data Vacuum Switches VS-V-PM/EM-ST

Type	Part no.
VS-V-EM-ST	10.06.02.00457
VS-V-PM-NC	10.06.02.00455
VS-V-PM-NO	10.06.02.00456

## Ordering Data Accessories Vacuum Switches VS-V-PM/EM-ST

Type	Cover ABDK-M8-4	Cover ABDK-ST	Connection cable M8-4
VS-V-EM-ST	10.06.02.00454	10.06.02.00453	10.06.02.00460

## Technical Data Vacuum Switches VS-V-PM/EM-ST

Type	Measured medium	Measuring range [bar]	Max. overpressure safety [bar]	Repeatability	Hysteresis	Switching capacity max. [A]	Switching frequency [Hz]
VS-V-EM-ST	Non-aggressive gases; dry, oil-free air	-1.0...0.0	6	± 3% of full-scale value	Fixed: 60...80 mbar	10	1
VS-V-PM-NC	Non-aggressive gases; dry, oil-free air	-1.0...0.0	6	± 3% of full-scale value	Fixed: approx. 40 mbar	-	-
VS-V-PM-NO	Non-aggressive gases; dry, oil-free air	-1.0...0.0	6	± 3% of full-scale value	Fixed: approx. 10 mbar	-	-

Schmalz – The Company  
Vacuum Suction Cups  
Special Grippers  
Gripping Systems  
Clamping Systems  
Mounting Elements  
Vacuum Generators  
Valve Technology  
Switches and Monitoring  
Filters and Connections  
Services  
Contact  
Glossary  
Index of Products

# Vacuum Switches VS-V-PM/EM-ST

Measuring range from -1 bar to 0 bar

Schmalz – The Company  
 Vacuum Suction Cups  
 Special Grippers  
 Gripping Systems  
 Clamping Systems  
 Mounting Elements  
 Vacuum Generators  
 Valve Technology  
 Switches and Monitoring  
 Filters and Connections  
 Services  
 Contact  
 Glossary  
 Index of Products



## Technical Data Vacuum Switches VS-V-PM/EM-ST

Type	Electrical connection	Control pressure range [bar]	Voltage	Flow rate max. [l/min]	Protection type IP	Operating temperature [°C]	Weight [g]
VS-V-EM-ST	Plug-in connection	-	max. 30V DC/ 250V AC V	-	65	0 ... 60	33
VS-V-PM-NC	-	1.5 ... 8.0	-	100	-	0 ... 50	33
VS-V-PM-NO	-	1.5 ... 8.0	-	100	-	0 ... 50	33



## Design Data Vacuum Switches VS-V-PM/EM-ST

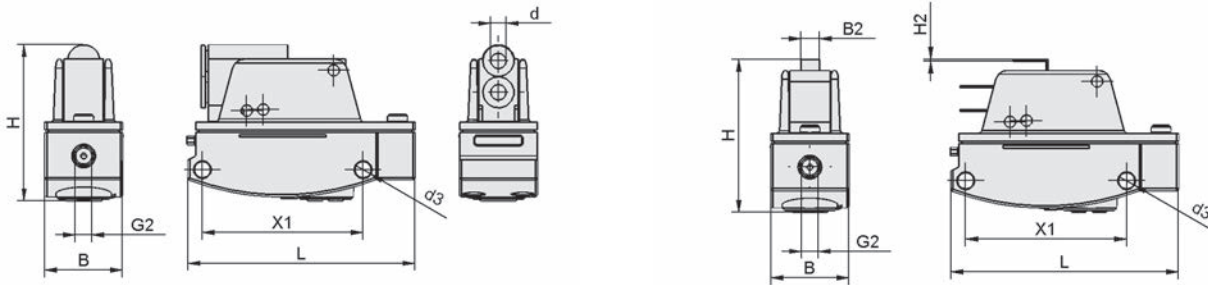

VS-V-PM

VS-V-EM-ST

Type	B [mm]	B2 [mm]	d [mm]	d3 [mm]	G2	H [mm]	H2 [mm]	L [mm]	X1 [mm]
VS-V-EM-ST	19.8	4.8	-	4.2	M5-F	36.1	0.5	58	41
VS-V-PM-NC	19.8	-	4	4.2	M5-F	40.0	-	58	41
VS-V-PM-NO	19.8	-	4	4.2	M5-F	40.0	-	58	41



# Vacuum Sensor VS-V-SA

Measuring range from -1 bar to 0 bar



Vacuum Sensor VS-V-SA

## Design

- Mini-sensor with housing and connection cable
- Available with either screw connector or plug connector
- Analog output signal (voltage output)

## Suitability for Industry Specific Applications

### Applications

- Electronic vacuum sensor for measurement of vacuum values close to the suction cup
- Remote evaluation of the signals
- Processing of output signals for example a stored program controller
- Ideal for monitoring the vacuum curve within a handling process
- For use in all areas of automated handling

## Our Highlights...

- Minimum size and low weight
- High measuring accuracy
- Vacuum connection with M3 or M5 thread or with diameter 4 or 6 mm plug-in tubes

## Your Benefits...

- Optimum installation in vacuum systems, even those subject to high rates of acceleration
- Precise output signals
- Flexible mounting facilities



## Designation Code Vacuum Sensor VS-V-SA

<b>VS</b>	-	<b>V</b>	-	<b>SA</b>	-	<b>M5-AG</b>
1		2		3		4

### 1 - Abbreviated designation

Code	Version
VS	VS

### 2 - Measuring range

Code	Measuring range in bar
V	-1 to 0

### 3 - Principle of function

Code	Type
SA	Sensor analoge

### 4 - Vacuum connection

Code	Connection
STR4	STR4 plug-in tube
STR6	STR6 plug-in tube
M3-AG	M3-AG (AG = male (M))
M5-AG	M5-AG

Vacuum switch VS-V-SA is delivered as a ready-to-connect product.



Schmalz – The Company  
Vacuum Suction Cups  
Special Grippers  
Gripping Systems  
Clamping Systems  
Mounting Elements  
Vacuum Generators  
Valve Technology  
Switches and Monitoring  
Filters and Connections  
Services  
Contact  
Glossary  
Index of Products

# Vacuum Sensor VS-V-SA

Measuring range from -1 bar to 0 bar

## Ordering Data Vacuum Sensor VS-V-SA

Type	Part no.
VS-V-SA STR4	10.06.02.00226
VS-V-SA STR6	10.06.02.00227
VS-V-SA M3-AG	10.06.02.00225
VS-V-SA M5-AG	10.06.02.00224

## Technical Data Vacuum Sensor VS-V-SA

Type	Measured medium	Measuring range [bar]	Max. overpressure safety [bar]	Inputs/outputs	Repeatability	Electrical connection
VS-V-SA	Non-aggressive gases; dry, oil-free air	-1.0...0.0	5	Analog: 1...5 V	± 1% of full-scale value	Cable

Type	Voltage	Protection type IP	Temperature influence	Operating temperature [°C]	Length of cable Lk [m]	Weight [g]
VS-V-SA	10-24V DC V	40	± 3% of full-scale value	0 ... 50	3	5

## Design Data Vacuum Sensor VS-V-SA

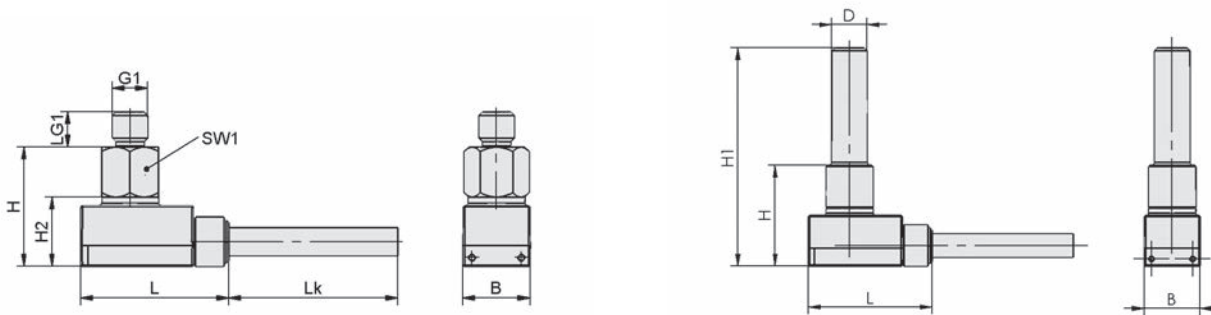

VS-V-SA-M3, VS-V-SA-M5

VS-V-SA-STR4, VS-V-SA-STR6

Type	B [mm]	D [mm]	G1	H [mm]	H1 [mm]	H2 [mm]	L [mm]	Lk [m]	LG1 [mm]	SW1 [mm]
VS-V-SA STR4	9.5	4	-	17.2	32.2	10	21	3	-	-
VS-V-SA STR6	9.5	6	-	17.2	37.2	10	21	3	-	-
VS-V-SA M3-AG	9.5	-	M3-M	16.9	-	10	21	3	3	8
VS-V-SA M5-AG	9.5	-	M5-M	16.9	-	10	21	3	5	8

Schmalz - The Company  
Vacuum Suction Cups  
Special Grippers  
Gripping Systems  
Clamping Systems  
Mounting Elements  
Vacuum Generators  
Valve Technology  
Switches and Monitoring  
Filters and Connections  
Services  
Contact  
Glossary  
Index of Products

# Vacuum and Pressure Switches VS/VSi

Measuring range from -1 bar to 10 bar

Keep everything in your sight with the new vacuum and pressure switches VS and VSi from Schmalz: The electronic switches are modular in design, simple to integrate in the automation environment and visible throughout the entire process thanks to the use of innovative communication technology.



- Measuring range: -1 to 10 bar
- Degree of protection: IP 65



Sensor without display; switching output: analog + NFC (VS)



Switch (VSi) for in-process measurements; digital switching output with IO-Link interface + NFC



Switch VSi with integrated display; digital switching output; IO-Link interface + NFC



IO-Link and NFC open new possibilities for communication

**MODULAR**

- Switch in two versions: without display and with integrated display
- Compact sensor unit for installation directly on the suction cup for measurement with no line losses

**VISIBLE**

- Device and process information is available in real time because the switch gathers direct measurements during the process and communicates with the controllers via IO-Link
- Device and process information can be parameterized and read on a smartphone via NFC
- Current vacuum or pressure level visible on the display

**INTEGRATED**

- Switch can be integrated into a system quickly and easily via IO-Link
- Process and device parameters can be quickly configured via IO-Link or NFC

- Schmalz – The Company
- Vacuum Suction Cups
- Special Grippers
- Gripping Systems
- Clamping Systems
- Mounting Elements
- Vacuum Generators
- Valve Technology
- Switches and Monitoring**
- Filters and Connections
- Services
- Contact
- Glossary
- Index of Products

# Vacuum and Pressure Switches VS / VSi

Measuring range -1 bar to 10 bar

## Selection Aid

Step 1 Select type	Step 2 Decide on measurement point	Step 3 Select display options	Step 4 Select electrical connection	Part no. / Illustration V = Vacuum P = Pressure VP = Vacuum / Pressure
Analog vacuum and pressure sensors VS Output: 1x analog	Measurement directly in the process Compact sensor unit for installation directly on the suction cup	No display ✓ PLC (analog) ✓ Smartphone (via NFC)	M8-4	VS-V-SA-M8-4 <span style="float:right">①</span> 10.06.02.00560
				VS-P10-SA-M8-4 <span style="float:right">②</span> 10.06.02.00561
				VS-VP8-SA-M8-4 <span style="float:right">③</span> 10.06.02.00562
Digital vacuum and pressure switches with IO-Link VSi Outputs: 2x standard IO (SIO) 1x IO-Link (IO)	Measurement directly in the process Compact switch for installation directly on the suction cup	No display ✓ PLC (via SIO / IO) ✓ Smartphone (via NFC)	M8-4	VSi-V-M8-4 <span style="float:right">④</span> 10.06.02.00567
				VSi-P10-M8-4 <span style="float:right">⑤</span> 10.06.02.00568
				VSi-VP8-M8-4 <span style="float:right">⑥</span> 10.06.02.00569
			M12-4	VSi-V-M12-4 <span style="float:right">⑦</span> 10.06.02.00570
				VSi-P10-M12-4 <span style="float:right">⑧</span> 10.06.02.00571
				VSi-VP8-M12-4 <span style="float:right">⑨</span> 10.06.02.00572
	Measurement on the user interface Switch with integrated control and indicator display for integration in the user interface	With integrated display ✓ PLC (via SIO / IO) ✓ Smartphone (via NFC) ✓ Integrated display	M8-4	VSi-V-D-M8-4 <span style="float:right">⑩</span> 10.06.02.00577
				VSi-P10-D-M8-4 <span style="float:right">⑪</span> 10.06.02.00578
				VSi-VP8-D-M8-4 <span style="float:right">⑫</span> 10.06.02.00579
M12-4	VSi-V-D-M12-4 <span style="float:right">⑬</span> 10.06.02.00580			
	VSi-P10-D-M12-4 <span style="float:right">⑭</span> 10.06.02.00581			
	VSi-VP8-D-M12-4 <span style="float:right">⑮</span> 10.06.02.00582			



VS.../VSi... without display

- ① VS-V-SA-M8-4
- ④ VSi-V-M8-4
- ⑦ VSi-V-M12-4
- ② VS-P10-SA-M8-4
- ⑤ VSi-P10-M8-4
- ⑧ VSi-P10-M12-4
- ③ VS-VP8-SA-M8-4
- ⑥ VSi-VP8-M8-4
- ⑨ VSi-VP8-M12-4



VSi...D with integrated display

- ⑩ VSi-V-D-M8-4
- ⑬ VSi-V-D-M12-4
- ⑪ VSi-P10-D-M8-4
- ⑭ VSi-P10-D-M12-4
- ⑫ VSi-VP8-D-M8-4
- ⑮ VSi-VP8-D-M12-4

Schmalz – The Company  
Vacuum Suction Cups  
Special Grippers  
Gripping Systems  
Clamping Systems  
Mounting Elements  
Vacuum Generators  
Valve Technology  
Switches and Monitoring  
Filters and Connections  
Services  
Contact  
Glossary  
Index of Products



# Vacuum and Pressure Sensors VS

Measuring range from -1 bar to 10 bar



Vacuum and Pressure Sensors VS

## Design

- Compact sensor unit with robust fiberglass reinforced plastic housing
- Operating mode display using LED that is visible from all sides
- M8-4 pin connection plug
- Installation via stainless steel vacuum, compressed air connection

## Suitability for Industry Specific Applications

### Applications

- Electronic sensor for constant and precise measurement of vacuum and pressure values
- Conversion of vacuum and pressure values into an analog output signal for the controller
- Compact sensor unit for installation directly on the suction cup, particularly in decentralized vacuum systems
- Output of device data such as type or operating instructions via smartphone

## Our Highlights...

- Electronic vacuum and pressure sensor with analog output
- Output on smartphone using NFC technology
- Compact size and low weight

## Your Benefits...

- Constant and precise monitoring of vacuum and overpressure
- Simple access to service, maintenance information and error messages
- Use in decentralized systems directly in the process; use in handling systems with maximum dynamics



## Designation Code Vacuum and Pressure Sensors VS

<b>VS</b>	-	<b>V</b>	-	<b>SA</b>	-	<b>M8-4</b>
1		2		3		4

### 1 - Abbreviated designation

Code	Version
VS	VS

### 2 - Measuring range

Code	Measuring range in bar
V	-1 to 0
VP8	-1 to 8
P10	0 to 10

### 3 - Principle of function

Code	Type
SA	Sensor analog

### 4 - Connection electrical

Code	Connection
M8-4	Male connect M8, 4-pole

Vacuum and pressure sensor VS is delivered as a ready-to-connect product (without connection cable).

The product consists of:

- Vacuum and pressure sensor of type VS - available as vacuum version, pressure version or combined version

Available accessories: connection cable, mounting bracket



Schmalz - The Company  
Vacuum Suction Cups  
Special Grippers  
Gripping Systems  
Clamping Systems  
Mounting Elements  
Vacuum Generators  
Valve Technology  
Switches and Monitoring  
Filters and Connections  
Services  
Contact  
Glossary  
Index of Products

# Vacuum and Pressure Sensors VS

Measuring range from -1 bar to 10 bar

## Ordering Data Vacuum and Pressure Sensors VS

Type	Part no.
VS V SA M8-4	10.06.02.00560
VS VP8 SA M8-4	10.06.02.00562
VS P10 SA M8-4	10.06.02.00561

## Ordering Data Accessories Vacuum and Pressure Sensors VS

Type	Part no.
Connection cable, M8 4-pole, 3 m, PUR, straight	ASK B-M8-4 3000 K-4P 10.06.02.00472
Mounting bracket	BEF-WIN 18x22x59 1 VS 10.06.02.00061

## Technical Data Vacuum and Pressure Sensors VS

Type	Measuring range [bar]	Measured medium	Max. overpressure safety [bar]	Repeatability	Inputs/outputs	Electrical connection
VS V SA M8-4	-1.0...0.0	Non-aggressive gases; dry, oil-free air	8	± 3% of full-scale value	Analog: 0...10 V	Male connect M8, 4 pole
VS VP8 SA M8-4	-1.0...8.0	Non-aggressive gases; dry, oil-free air	12	± 3% of full-scale value	Analog: 0...10 V	Male connect M8, 4 pole
VS P10 SA M8-4	0.0...10.0	Non-aggressive gases; dry, oil-free air	15	± 3% of full-scale value	Analog: 0...10 V	Male connect M8, 4 pole

Type	Connection	Voltage	Current consumption [mA]	Protection type IP	Temperature influence	Operating temperature [°C]	Weight [g]
VS V SA M8-4	G1/8"-M + M5-F	15-30V DC	10	65	± 3% of full-scale value	0 ... 50	12
VS VP8 SA M8-4	G1/8"-M + M5-F	15-30V DC	10	65	± 3% of full-scale value	0 ... 50	12
VS P10 SA M8-4	G1/8"-M + M5-F	15-30V DC	10	65	± 3% of full-scale value	0 ... 50	12

## Design Data Vacuum and Pressure Sensors VS

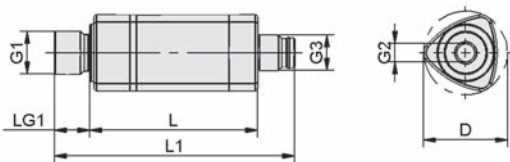

Type	D [mm]	G1	G2	G3	L [mm]	L1 [mm]	LG1 [mm]
VS V SA M8-4	20	G1/8"-M	M5-F	M8x1-M	38	55	8
VS VP8 SA M8-4	20	G1/8"-M	M5-F	M8x1-M	38	55	8
VS P10 SA M8-4	20	G1/8"-M	M5-F	M8x1-M	38	55	8

Schmalz - The Company  
Vacuum Suction Cups  
Special Grippers  
Gripping Systems  
Clamping Systems  
Mounting Elements  
Vacuum Generators  
Valve Technology  
Switches and Monitoring  
Filters and Connections  
Services  
Contact  
Glossary  
Index of Products

# Vacuum and Pressure Switches VSi

Measuring range from -1 bar to 10 bar



Vacuum and Pressure Switches VSi

## Suitability for Industry Specific Applications

### Applications

- Electronic vacuum and pressure switch with IO-Link interface for measuring and monitoring vacuum and overpressure in automation and handling systems
- Input and output of parameters via the controller
- Sensor unit can be positioned independently from the control and indicator display in the system
- Compact switch for installation directly on the suction cup, particularly in decentralized vacuum systems
- Setting and programming of the vacuum and pressure switch even at points in the process that are difficult to work on manually
- Output of device data such as type or operating instructions via smartphone, even with variants without display

### Design

- Switch with compact units in two designs: without display or with integrated display
- Robust fiberglass reinforced plastic housing
- Installation via stainless steel vacuum, compressed air connection and with optional additional mounting bracket
- M8-4 pin or M12-4 pin connection plug
- Mode and switching point display using LEDs that are visible from all sides

### Our Highlights...

- Electronic vacuum and pressure switch, available with and without display
- Output and configuration via smartphone using NFC technology
- Communication in all standard fieldbus systems via IO-Link interface

### Your Benefits...

- Precise measurement and output of digital signals
- Simple access to service and maintenance information; mobile display of detailed error messages
- Input and output of all relevant process data via the controller



## Designation Code Vacuum and Pressure Switches VSi



#### 1 - Abbreviated designation

Code	Version
VSi	VSi (IO-Link)

#### 2 - Measuring range

Code	Measuring range in bar
V	-1 to 0
VP8	-1 to 8
P10	0 to 10

#### 3 - Display

Code	Type
D	With integrated display

#### 4 - Connection electrical

Code	Connection
M8-4	Male connect M8, 4-pole
M12-4	Male connect M12, 4-pole

Vacuum and pressure switch VSi is delivered as a ready-to-connect product (without connection cable).

The product consists of:

- Vacuum and pressure switch of type VSi - available as vacuum version, pressure version or combined version without display or with integrated display

Available accessories: connection cable, mounting bracket



# Vacuum and Pressure Switches VSi

Measuring range from -1 bar to 10 bar



## Ordering Data Vacuum and Pressure Switches VSi

Type	Part no.
VSi V M8-4	10.06.02.00567
VSi V D M8-4	10.06.02.00577
VSi VP8 M8-4	10.06.02.00569
VSi VP8 D M8-4	10.06.02.00579
VSi P10 M8-4	10.06.02.00568
VSi P10 D M8-4	10.06.02.00578
VSi V M12-4	10.06.02.00570
VSi V D M12-4	10.06.02.00580
VSi VP8 M12-4	10.06.02.00572
VSi VP8 D M12-4	10.06.02.00582
VSi P10 M12-4	10.06.02.00571
VSi P10 D M12-4	10.06.02.00581



## Ordering Data Accessories Vacuum and Pressure Switches VSi

Type	Part no.
Connection cable, M8 4-pole, 5 m, PUR, straight	ASK B-M8-4 5000 K-4P
Connection cable, M12 4-pole, 5 m, PUR, straight	ASK B-M12-4 5000 K-4P
Mounting bracket	BEF-WIN 18x22x59 1 VS



## Technical Data Vacuum and Pressure Switches VSi

Type	Measured medium	Measuring range [bar]	Max. overpressure safety [bar]	Repeatability	Switching capacity max. [mA]	Hysteresis	Inputs/outputs
VSi V M8-4	Non-aggressive gases; dry, oil-free air	-1.0...0.0	8	± 3% of full-scale value	100	Adjustable	2 digital
VSi VP8 M8-4	Non-aggressive gases; dry, oil-free air	-1.0...8.0	12	± 3% of full-scale value	100	Adjustable	2 digital
VSi P10 M8-4	Non-aggressive gases; dry, oil-free air	0.0...10.0	15	± 3% of full-scale value	100	Adjustable	2 digital
VSi V M12-4	Non-aggressive gases; dry, oil-free air	-1.0...0.0	8	± 3% of full-scale value	100	Adjustable	2 digital
VSi VP8 M12-4	Non-aggressive gases; dry, oil-free air	-1.0...8.0	12	± 3% of full-scale value	100	Adjustable	2 digital
VSi P10 M12-4	Non-aggressive gases; dry, oil-free air	0.0...10.0	15	± 3% of full-scale value	100	Adjustable	2 digital

Type	Indication	Electrical connection	Connection	Voltage	Current consumption [mA]	Protection type IP	Temperature influence	Operating temperature [°C]	Weight [g]
VSi V M8-4	LED	Male connect M8, 4 pole	G1/8"-M + M5-F	10-30V DC	35	65	± 3% of full-scale value	0 ... 50	12
VSi VP8 M8-4	LED	Male connect M8, 4 pole	G1/8"-M + M5-F	10-30V DC	35	65	± 3% of full-scale value	0 ... 50	12
VSi P10 M8-4	LED	Male connect M8, 4 pole	G1/8"-M + M5-F	10-30V DC	35	65	± 3% of full-scale value	0 ... 50	12
VSi V M12-4	LED	Male connect M12, 4 pol	G1/8"-M + M5-F	10-30V DC	35	65	± 3% of full-scale value	0 ... 50	12
VSi VP8 M12-4	LED	Male connect M12, 4 pol	G1/8"-M + M5-F	10-30V DC	35	65	± 3% of full-scale value	0 ... 50	12
VSi P10 M12-4	LED	Male connect M12, 4 pol	G1/8"-M + M5-F	10-30V DC	35	65	± 3% of full-scale value	0 ... 50	12

# Vacuum and Pressure Switches VSi

Measuring range from -1 bar to 10 bar



## Design Data Vacuum and Pressure Switches VSi

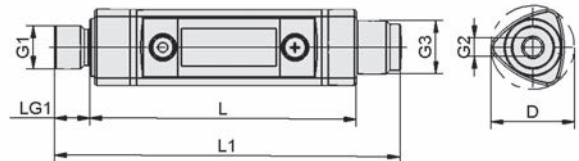
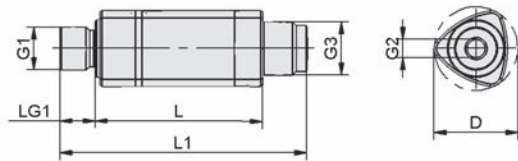

VSi

VSi-D

Type	D [mm]	G1	G2	G3	L [mm]	L1 [mm]	LG1 [mm]
VSi V M8-4	20	G1/8"-M	M5-F	M8x1-M	38	55	8
VSi V D M8-4	20	G1/8"-M	M5-F	M8x1-M	61	78	8
VSi VP8 M8-4	20	G1/8"-M	M5-F	M8x1-M	38	55	8
VSi VP8 D M8-4	20	G1/8"-M	M5-F	M8x1-M	61	78	8
VSi P10 M8-4	20	G1/8"-M	M5-F	M8x1-M	38	55	8
VSi P10 D M8-4	20	G1/8"-M	M5-F	M8x1-M	61	78	8
VSi V M12-4	20	G1/8"-M	M5-F	M12x1-M	38	56	8
VSi V D M12-4	20	G1/8"-M	M5-F	M12x1-M	61	79	8
VSi VP8 M12-4	20	G1/8"-M	M5-F	M12x1-M	38	56	8
VSi VP8 D M12-4	20	G1/8"-M	M5-F	M12x1-M	61	79	8
VSi P10 M12-4	20	G1/8"-M	M5-F	M12x1-M	38	56	8
VSi P10 D M12-4	20	G1/8"-M	M5-F	M12x1-M	61	79	8

Schmalz – The Company  
 Vacuum Suction Cups  
 Special Grippers  
 Gripping Systems  
 Clamping Systems  
 Mounting Elements  
 Vacuum Generators  
 Valve Technology  
 Switches and Monitoring  
 Filters and Connections  
 Services  
 Contact  
 Glossary  
 Index of Products



# Vacuum and Pressure Switches VS-V/P-W-D-K(-2C)

Measuring range from -1 bar to 10 bar



## Suitability for Industry Specific Applications

### Applications

- Vacuum and pressure switch for use in vacuum and pressure systems for process monitoring and optimizing cycle times
- Creating control circuits to improve the efficiency of systems
- The switch can be mounted in panels due to its cubic construction; optional mounting frame with a transparent protective cap
- Can be installed in handling systems directly thanks to its small design and low weight



Vacuum and Pressure Switches VS-V/P-W-D-K(-2C)

### Design

- Electronic switch in a stable plastic housing made from polycarbonate
- Switch with either a one or two color display
- Connection for measuring with G1/8" female thread (switch with one color display) or G1/8" male thread (switch with two color display)
- Hysteresis and comparator mode
- 2 m connection cable
- Mounting bracket and mounting frame for mounting into switch panel available as accessories

### Our Highlights...

- All functions are set using an intelligent menu structure
- Integrated automatic setting of switching point
- Anti-chattering function with adjustable response times

### Your Benefits...

- Fast and easy installation or adjusting of any settings
- Optimal switching points are determined automatically using the process parameters
- Stable switching output even in the event of sudden, brief fluctuations in the main vacuum

- Schmalz – The Company
- Vacuum Suction Cups
- Special Grippers
- Gripping Systems
- Clamping Systems
- Mounting Elements
- Vacuum Generators
- Valve Technology
- Switches and Monitoring**
- Filters and Connections
- Services
- Contact
- Glossary
- Index of Products



# Vacuum and Pressure Switches VS-V/P-W-D-K(-2C)

Measuring range from -1 bar to 10 bar

## Designation Code Vacuum and Pressure Switches VS-V/P-W-D-K(-2C)

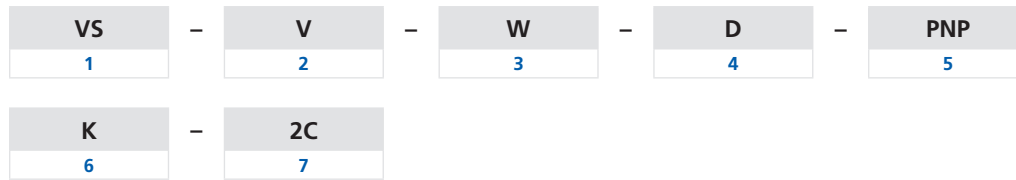

### 1 – Abbreviated designation

Code	Version
VS	VS

### 2 – Measuring range

Code	Measuring range in bar
V	-1 to 0
P10	0 to 10

### 3 – Design

Code	Type
W	Cube shape

### 4 – Display

Code	Type
D	Digital display

### 5 – Switching function

Code	Type
NPN	Switches to minus
PNP	Switches to plus

### 6 – Cable

Code	Cable
K	Cable

### 7 – Display

Code	Type
2C	Two-colored display

Vacuum and pressure switch VS-V/P-W-D-K(-2C) is delivered as a ready-to-connect product.

Available accessories: mounting bracket, mounting frame

## Ordering Data Vacuum and Pressure Switches VS-V/P-W-D-K(-2C)

Type	Part no.
VS-V-W-D-NPN-K	10.06.02.00417
VS-V-W-D-PNP-K	10.06.02.00418
VS-V-W-D-NPN-K-2C	10.06.02.00421
VS-V-W-D-PNP-K-2C	10.06.02.00422
VS-P10-W-D-NPN-K	10.06.02.00419
VS-P10-W-D-PNP-K	10.06.02.00420
VS-P10-W-D-NPN-K-2C	10.06.02.00423
VS-P10-W-D-PNP-K-2C	10.06.02.00424

## Ordering Data Accessories Vacuum and Pressure Switches VS-V/P-W-D-K(-2C)

Type	Mounting bracket	Mounting frame
VS-V-W-D-NPN-K	10.06.02.00425	10.06.02.00426
VS-V-W-D-PNP-K	10.06.02.00425	10.06.02.00426
VS-V-W-D-NPN-K-2C	10.06.02.00425	10.06.02.00427
VS-V-W-D-PNP-K-2C	10.06.02.00425	10.06.02.00427
VS-P10-W-D-NPN-K	10.06.02.00425	10.06.02.00426
VS-P10-W-D-PNP-K	10.06.02.00425	10.06.02.00426
VS-P10-W-D-NPN-K-2C	10.06.02.00425	10.06.02.00427
VS-P10-W-D-PNP-K-2C	10.06.02.00425	10.06.02.00427



Schmalz – The Company  
Vacuum Suction Cups  
Special Grippers  
Gripping Systems  
Clamping Systems  
Mounting Elements  
Vacuum Generators  
Valve Technology  
Switches and Monitoring  
Filters and Connections  
Services  
Contact  
Glossary  
Index of Products

# Vacuum and Pressure Switches VS-V/P-W-D-K(-2C)

Measuring range from -1 bar to 10 bar



## Technical Data Vacuum and Pressure Switches VS-V/P-W-D-K(-2C)

Type	Measured medium	Measuring range [bar]	Max. overpressure safety [bar]	Repeatability	Hysteresis	Inputs/ outputs	Switching capacity max. [mA]
VS-V-W-D-NPN-K	Non-aggressive gases; dry, oil-free air	-1.0...0.0	3	± 0.2% of max. set value	Adjustable: 0 to 100% of set value or comparator mode	2 digital	80
VS-V-W-D-PNP-K	Non-aggressive gases; dry, oil-free air	-1.0...0.0	3	± 0.2% of max. set value	Adjustable: 0 to 100% of set value or comparator mode	2 digital	80
VS-V-W-D-NPN-K-2C	Non-aggressive gases; dry, oil-free air	-1.0...0.0	3	± 0.2% of max. set value	Adjustable: 0 to 100% of set value or comparator mode	1 digital	125
VS-V-W-D-PNP-K-2C	Non-aggressive gases; dry, oil-free air	-1.0...0.0	3	± 0.2% of max. set value	Adjustable: 0 to 100% of set value or comparator mode	1 digital	125
VS-P10-W-D-NPN-K	Non-aggressive gases; dry, oil-free air	0.0...10.0	15	± 0.2% of max. set value	Adjustable: 0 to 100% of set value or comparator mode	2 digital	80
VS-P10-W-D-PNP-K	Non-aggressive gases; dry, oil-free air	0.0...10.0	15	± 0.2% of max. set value	Adjustable: 0 to 100% of set value or comparator mode	2 digital	80
VS-P10-W-D-NPN-K-2C	Non-aggressive gases; dry, oil-free air	0.0...10.0	15	± 0.2% of max. set value	Adjustable: 0 to 100% of set value or comparator mode	1 digital	125
VS-P10-W-D-PNP-K-2C	Non-aggressive gases; dry, oil-free air	0.0...10.0	15	± 0.2% of max. set value	Adjustable: 0 to 100% of set value or comparator mode	1 digital	125

Type	Indication	Electrical connection	Connection	Measured-value display	Voltage	Current consumption [mA]	Protection type IP	Operating temperature [°C]	Weight [g]
VS-V-W-D-NPN-K	2xLED	Cable	G1/8"-F	3-digit 7-segment LED	12-24V DC	55	40	0 ... 50	105
VS-V-W-D-PNP-K	2xLED	Cable	G1/8"-F	3-digit 7-segment LED	12-24V DC	55	40	0 ... 50	105
VS-V-W-D-NPN-K-2C	-	Cable	G1/8"-M	3-digit 7-segment LED	12-24V DC	45	40	0 ... 50	75
VS-V-W-D-PNP-K-2C	-	Cable	G1/8"-M	3-digit 7-segment LED	12-24V DC	45	40	0 ... 50	75
VS-P10-W-D-NPN-K	2xLED	Cable	G1/8"-F	3-digit 7-segment LED	12-24V DC	55	40	0 ... 50	105
VS-P10-W-D-PNP-K	2xLED	Cable	G1/8"-F	3-digit 7-segment LED	12-24V DC	55	40	0 ... 50	105
VS-P10-W-D-NPN-K-2C	-	Cable	G1/8"-M	3-digit 7-segment LED	12-24V DC	45	40	0 ... 50	75
VS-P10-W-D-PNP-K-2C	-	Cable	G1/8"-M	3-digit 7-segment LED	12-24V DC	45	40	0 ... 50	75

Schmalz – The Company  
Vacuum Suction Cups  
Special Grippers  
Gripping Systems  
Clamping Systems  
Mounting Elements  
Vacuum Generators  
Valve Technology  
Switches and Monitoring  
Filters and Connections  
Services  
Contact  
Glossary  
Index of Products



# Vacuum and Pressure Switches VS-V/P-W-D-K(-2C)

Measuring range from -1 bar to 10 bar



## Design Data Vacuum and Pressure Switches VS-V/P-W-D-K(-2C)

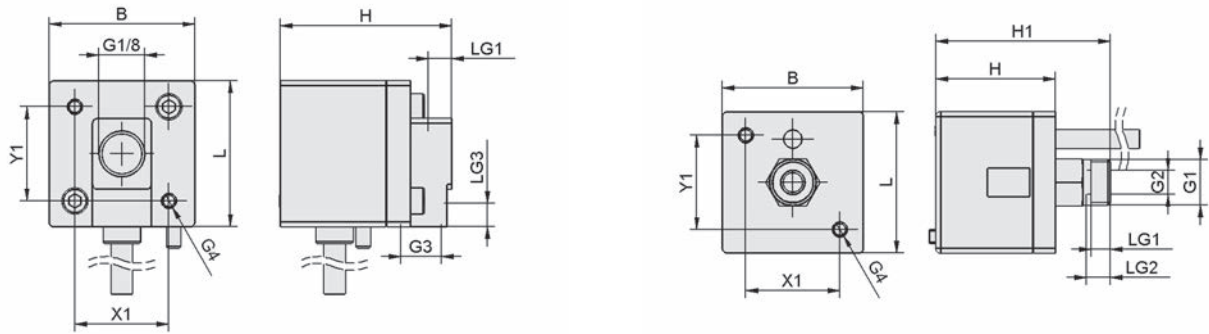

VS-V-W-D-K, VS-P10-W-D-K

VS-V-W-D-K-2C, VS-P10-W-D-K-2C

Type	B [mm]	G1	G2	G3	G4	H [mm]	H1 [mm]
VS-V-W-D-NPN-K	31	G1/8"-F	-	G1/8"-F	M3-F	36.5	-
VS-V-W-D-PNP-K	31	G1/8"-F	-	G1/8"-F	M3-F	36.5	-
VS-V-W-D-NPN-K-2C	30	G1/8"-M	M5-F	-	M3-F	25.4	37.1
VS-V-W-D-PNP-K-2C	30	G1/8"-M	M5-F	-	M3-F	25.4	37.1
VS-P10-W-D-NPN-K	31	G1/8"-F	-	G1/8"-F	M3-F	36.5	-
VS-P10-W-D-PNP-K	31	G1/8"-F	-	G1/8"-F	M3-F	36.5	-
VS-P10-W-D-NPN-K-2C	30	G1/8"-M	M5-F	-	M3-F	25.4	37.1
VS-P10-W-D-PNP-K-2C	30	G1/8"-M	M5-F	-	M3-F	25.4	37.1

Type	L [mm]	LG1 [mm]	LG2 [mm]	LG3 [mm]	X1 [mm]	Y1 [mm]
VS-V-W-D-NPN-K	31	5	-	5	20	20
VS-V-W-D-PNP-K	31	5	-	5	20	20
VS-V-W-D-NPN-K-2C	30	4	5	-	20	20
VS-V-W-D-PNP-K-2C	30	4	5	-	20	20
VS-P10-W-D-NPN-K	31	5	-	5	20	20
VS-P10-W-D-PNP-K	31	5	-	5	20	20
VS-P10-W-D-NPN-K-2C	30	4	5	-	20	20
VS-P10-W-D-PNP-K-2C	30	4	5	-	20	20

Schmalz – The Company  
Vacuum Suction Cups  
Special Grippers  
Gripping Systems  
Clamping Systems  
Mounting Elements  
Vacuum Generators  
Valve Technology  
Switches and Monitoring  
Filters and Connections  
Services  
Contact  
Glossary  
Index of Products



# Electronic Vacuum and Pressure Switches

## Vacuum Switches VS-V-SD



Measuring range from -1 bar to 0 bar



### Suitability for Industry Specific Applications

#### Applications

- Electronic vacuum switch for measurement of vacuum values close to the suction cup
- Remote evaluation of the signals
- Processing of output signals for example a stored program controller
- Ideal for outputting part presence signals
- For use in all areas of automated handling



Vacuum Switches VS-V-SD

#### Design

- Mini switch with housing and firmly attached connection cable (3 m)
- Available with either screw connector or plug connector
- Digital output signal (permanently set to -600 mbar)

#### Our Highlights...

- Minimum size and low weight
- High measuring accuracy
- Vacuum connection with M3 or M5 thread or with diameter 4 or 6 mm plug-in tubes, according to version

#### Your Benefits...

- Optimum installation in vacuum systems, even those subject to high rates of acceleration
- Precise output signals
- Flexible mounting facilities



### Designation Code Vacuum Switches VS-V-SD



#### 1 - Abbreviated designation

Code	Version
VS	VS

#### 2 - Measuring range

Code	Measuring range in bar
V	-1 to 0

#### 3 - Principle of function

Code	Type
SD	Sensor digital

#### 4 - Switching point

Code	Switching point in mbar
60	Switching point -600

#### 5 - Vacuum connection

Code	Connection
STR4	STR4 plug-in tube
STR6	STR6 plug-in tube
M3-AG	M3-AG (AG = male (M))
M5-AG	M5-AG

Vacuum switch VS-V-SD is delivered as a ready-to-connect product.



### Designation Code Vacuum Switches VS-V-SD

Type	Part no.
VS-V-SD 60 STR4	10.06.02.00259
VS-V-SD 60 STR6	10.06.02.00260
VS-V-SD 60 M3-AG	10.06.02.00258
VS-V-SD 60 M5-AG	10.06.02.00257

Measuring range from -1 bar to 0 bar



**Technical Data Vacuum Switches VS-V-SD**

Type	Measured medium	Measuring range [bar]	Max. overpressure safety [bar]	Repeatability	Hysteresis	Inputs/ outputs	Switching capacity max. [mA]	Switching point
VS-V-SD 60 STR4	Non-aggressive gases; dry, oil-free air	-1.0...0.0	5	± 1% of full-scale value	Fixed: approx. 20 mbar	1 digital	60	- 600
VS-V-SD 60 STR6	Non-aggressive gases; dry, oil-free air	-1.0...0.0	5	± 1% of full-scale value	Fixed: approx. 20 mbar	1 digital	60	- 600
VS-V-SD 60 M3-AG	Non-aggressive gases; dry, oil-free air	-1.0...0.0	5	± 1% of full-scale value	Fixed: approx. 20 mbar	1 digital	60	- 600
VS-V-SD 60 M5-AG	Non-aggressive gases; dry, oil-free air	-1.0...0.0	5	± 1% of full-scale value	Fixed: approx. 20 mbar	1 digital	60	- 600

Type	Indication	Electrical connection	Voltage	Protection type IP	Temperature influence	Operating temperature [°C]	Length of cable Lk [m]	Weight [g]
VS-V-SD 60 STR4	LED	Cable	10-24V DC V	40	± 3% of full-scale value	0 ... 50	3	5
VS-V-SD 60 STR6	LED	Cable	10-24V DC V	40	± 3% of full-scale value	0 ... 50	3	5
VS-V-SD 60 M3-AG	LED	Cable	10-24V DC V	40	± 3% of full-scale value	0 ... 50	3	5
VS-V-SD 60 M5-AG	LED	Cable	10-24V DC V	40	± 3% of full-scale value	0 ... 50	3	5



**Design Data Vacuum Switches VS-V-SD**

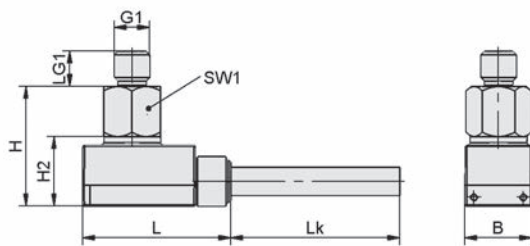

VS-V-SD-M3, VS-V-SD-M5

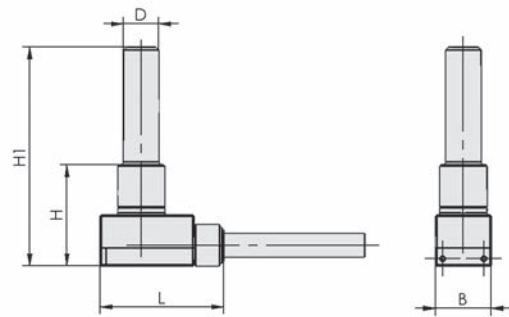

VS-V-SD-STR4, VS-V-SD-STR6

Type	B [mm]	D [mm]	G1	H [mm]	H1 [mm]	H2 [mm]	L [mm]	LG1 [mm]	Lk [m]	SW1 [mm]
VS-V-SD 60 STR4	9.5	4	-	17.2	32.2	10	21	-	3	-
VS-V-SD 60 STR6	9.5	6	-	17.2	37.2	10	21	-	3	-
VS-V-SD 60 M3-AG	9.5	-	M3-M	16.9	-	10	21	3	3	8
VS-V-SD 60 M5-AG	9.5	-	M5-M	16.9	-	10	21	5	3	8



# Vacuum and Pressure Switches VS-V/P-AH/AV-T

Measuring range from -1 bar to 10 bar



## Suitability for Industry Specific Applications

### Applications

- Electronic process monitoring, optimization of cycle times, energy saving functions
- Can be used as a measuring and switching element
- Suitable vacuum switch for use in very dynamic handling systems



Vacuum and Pressure Switches VS-V/P-AH/AV-T

### Design

- Plastic housing in 10 mm design
- Adapter plate for quick mounting, either vertically or horizontally
- Teach button integrated into the cover
- Transparent cover over the LED indicator
- Power and control connections via 4-pin M8 connector
- Optionally available with M5 vacuum, pressure connection or 6 mm plug-in tube

### Our Highlights...

- Switching points adjustable with the "teach" button
- Two digital switch outputs
- Two color LED indicator
- For vertical or horizontal mounting
- Electronic vacuum/pressure sensor

### Your Benefits...

- Quick adjustment of the process
- Makes further switching elements unnecessary
- Easily visible status indication
- Space saving installation
- Very precise switching and repeatability

- Schmalz – The Company
- Vacuum Suction Cups
- Special Grippers
- Gripping Systems
- Clamping Systems
- Mounting Elements
- Vacuum Generators
- Valve Technology
- Switches and Monitoring
- Filters and Connections
- Services
- Contact
- Glossary
- Index of Products



# Vacuum and Pressure Switches VS-V/P-AH/AV-T

Measuring range from -1 bar to 10 bar



## Designation Code Vacuum and Pressure Switches VS-V/P-AH/AV-T



### 1 – Abbreviated designation

Code	Version
VS	VS

### 2 – Measuring range

Code	Measuring range in bar
V	-1 to 0
P10	0 to 10

### 3 – Connection

Code	Connection
AH	Horizontal
AV	Vertical

### 4 – Switching point

Code	Switching point adjustment
T	Teach button

### 5 – Switching function

Code	Type
PNP	Switches to plus

### 6 – Connection electrical

Code	Connection
M8-4	Male connect M8, 4-pole

### 7 – Product addition

Code	Type
S	Hysteresis fixed

Vacuum and pressure switch VS-V/P-AH/AV-T is delivered as a ready-to-connect product (without connection cable).

Available accessories: connection cable, connection adapter



## Ordering Data Vacuum and Pressure Switches VS-V/P-AH/AV-T

Type	Part no.
VS-V-AH-T-PNP M8-4	10.06.02.00295
VS-V-AH-T-PNP M8-4 S	10.06.02.00294
VS-V-AV-T-PNP M8-4	10.06.02.00293
VS-V-AV-T-PNP M8-4 S	10.06.02.00292
VS-P10-AH-T-PNP M8-4	10.06.02.00383
VS-P10-AH-T-PNP M8-4 S	10.06.02.00382
VS-P10-AV-T-PNP M8-4	10.06.02.00385
VS-P10-AV-T-PNP M8-4 S	10.06.02.00384



## Ordering Data Accessories Vacuum and Pressure Switches VS-V/P-AH/AV-T

Type	Part no.
Connection cable, M8 4-pole, 5 m, PUR, 90°	ASK WB-M8-4 5000 K-4P 10.06.02.00032
Connection cable, M8 4-pole, 5 m, PUR, straight	ASK B-M8-4 5000 K-4P 10.06.02.00031
Connection adapter screw thread M5-AG	ADAP-VS M5-AG-1.3x16 10.06.02.00299
Connection adapter plug-in tube STR6	ADAP-VS 6-1.3x16 10.06.02.00300



Schmalz – The Company  
Vacuum Suction Cups  
Special Grippers  
Gripping Systems  
Clamping Systems  
Mounting Elements  
Vacuum Generators  
Valve Technology  
Switches and Monitoring  
Filters and Connections  
Services  
Contact  
Glossary  
Index of Products

# Vacuum and Pressure Switches VS-V/P-AH/AV-T

Measuring range from -1 bar to 10 bar



## Technical Data Vacuum and Pressure Switches VS-V/P-AH/AV-T

Type	Measured medium	Measuring range [bar]	Max. overpressure safety [bar]	Repeatability	Hysteresis	Inputs/ outputs
VS-V-AH-T-PNP M8-4	Non-aggressive gases; dry, oil-free air	-1.0...0.0	5	± 1% of full-scale value	Adjustable	2 digital
VS-V-AH-T-PNP M8-4 S	Non-aggressive gases; dry, oil-free air	-1.0...0.0	5	± 1% of full-scale value	Fixed: approx. 20 mbar	2 digital
VS-V-AV-T-PNP M8-4	Non-aggressive gases; dry, oil-free air	-1.0...0.0	5	± 1% of full-scale value	Adjustable	2 digital
VS-V-AV-T-PNP M8-4 S	Non-aggressive gases; dry, oil-free air	-1.0...0.0	5	± 1% of full-scale value	Fixed: approx. 20 mbar	2 digital
VS-P10-AH-T-PNP M8-4	Non-aggressive gases; dry, oil-free air	0.0...10.0	15	± 1% of full-scale value	Adjustable	2 digital
VS-P10-AH-T-PNP M8-4 S	Non-aggressive gases; dry, oil-free air	0.0...10.0	15	± 1% of full-scale value	Fixed: 2% of full-scale value	2 digital
VS-P10-AV-T-PNP M8-4	Non-aggressive gases; dry, oil-free air	0.0...10.0	15	± 1% of full-scale value	Adjustable	2 digital
VS-P10-AV-T-PNP M8-4 S	Non-aggressive gases; dry, oil-free air	0.0...10.0	15	± 1% of full-scale value	Fixed: 2% of full-scale value	2 digital

Type	Switching capacity max. [mA]	Indication	Electrical connection	Voltage	Current consumption [mA]	Protection type IP	Operating temperature [°C]	Temperature influence	Weight [g]
VS-V-AH-T-PNP M8-4	200	LED	Male connect M8, 4 pole	10-30V DC	20	40	0 ... 60	± 3% of full-scale value	6
VS-V-AH-T-PNP M8-4 S	200	LED	Male connect M8, 4 pole	10-30V DC	20	40	0 ... 60	± 3% of full-scale value	6
VS-V-AV-T-PNP M8-4	200	LED	Male connect M8, 4 pole	10-30V DC	20	40	0 ... 60	± 3% of full-scale value	6
VS-V-AV-T-PNP M8-4 S	200	LED	Male connect M8, 4 pole	10-30V DC	20	40	0 ... 60	± 3% of full-scale value	6
VS-P10-AH-T-PNP M8-4	200	2xLED	Male connect M8, 4 pole	10-30V DC	-	40	0 ... 60	± 3% of full-scale value	6
VS-P10-AH-T-PNP M8-4 S	200	2xLED	Male connect M8, 4 pole	10-30V DC	-	40	0 ... 60	± 3% of full-scale value	6
VS-P10-AV-T-PNP M8-4	200	2xLED	Male connect M8, 4 pole	10-30V DC	-	40	0 ... 60	± 3% of full-scale value	6
VS-P10-AV-T-PNP M8-4 S	200	2xLED	Male connect M8, 4 pole	10-30V DC	-	40	0 ... 60	± 3% of full-scale value	6

# Vacuum and Pressure Switches VS-V/P-AH/AV-T

Measuring range from -1 bar to 10 bar



## Design Data Vacuum and Pressure Switches VS-V/P-AH/AV-T

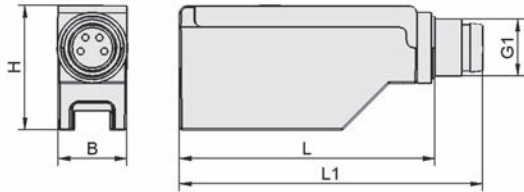

VS-V, VS-P10

Type	B [mm]	G1	H [mm]	L [mm]	L1 [mm]
VS-V-AH-T-PNP M8-4	10	M8-M	17.5	36.2	43.0
VS-V-AH-T-PNP M8-4 S	10	M8-M	17.5	36.2	43.0
VS-V-AV-T-PNP M8-4	10	M8-M	16.4	41.2	48.0
VS-V-AV-T-PNP M8-4 S	10	M8-M	16.4	41.2	48.0
VS-P10-AH-T-PNP M8-4	10	M8-M	17.5	36.2	43.0
VS-P10-AH-T-PNP M8-4 S	10	M8-M	17.5	36.2	43.0
VS-P10-AV-T-PNP M8-4	10	M8-M	16.4	41.2	48.0
VS-P10-AV-T-PNP M8-4 S	10	M8-M	16.4	41.2	48.0

# Vacuum Regulators VR

Working range from -990 mbar to -14 mbar



## Suitability for Industry Specific Applications

### Applications

- Compensation for the pressure variations inherent in vacuum generators
- Also suitable for measuring and testing tasks



Vacuum Regulators VR

### Design

- Vacuum regulator in a robust aluminum housing; diaphragm made of FPM
- Continuous adjustment with the aid of a spindle

### Our Highlights...

- Mechanically adjustable vacuum regulator
- Constant regulation of the vacuum

### Your Benefits...

- Precise manual adjustment with very good repeatability
- Very precise maintenance of the set value, unaffected by pressure variations caused by the vacuum generator



## Designation Code Vacuum Regulators VR



#### 1 – Abbreviated designation

Code	Version
VR	VR

#### 2 – Connection

Code	Connection
G1/4-IG	G1/4-IG (IG = female (F))
G3/8-IG	G3/8-IG

#### 3 – Possibility for mounting

Code	Possibility for mounting
HW	Holding angle

Vacuum regulator VR is delivered as a ready-to-connect product, including holding angle.



Schmalz – The Company  
Vacuum Suction Cups  
Special Grippers  
Gripping Systems  
Clamping Systems  
Mounting Elements  
Vacuum Generators  
Valve Technology  
Switches and Monitoring  
Filters and Connections  
Services  
Contact  
Glossary  
Index of Products



# Vacuum Regulators VR

Working range from -990 mbar to -14 mbar



## Ordering Data Vacuum Regulators VR

Type*	Part no.
VR G1/4-IG HW	10.05.05.00075
VR G3/8-IG HW	10.05.05.00026

\*Suitable manometers can be found under "Manometer VAM"



## Technical Data Vacuum Regulators VR

Type	Vacuum range	Repeatability	Flow rate max. [l/min]	Flow rate max. [m³/h]	Operating temperature [°C]	Weight [kg]	Pressure max. [bar]
VR G1/4-IG HW	-950 ... -25	± 2% of full-scale value	200	12	5 ... 60	0.20	5
VR G3/8-IG HW	-990 ... -14	5 mbar	270	17	5 ... 60	0.65	5



## Design Data Vacuum Regulators VR

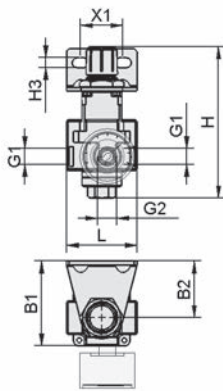

VR G1/4-IG

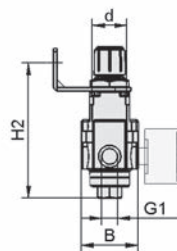

VR G3/8-IG

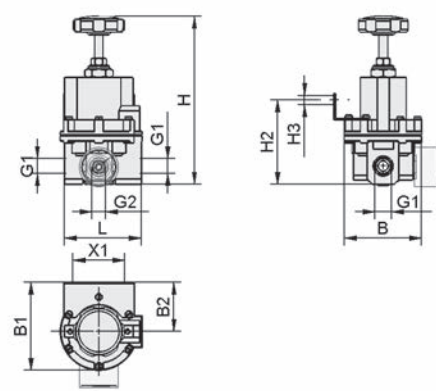

Type	B [mm]	B1 [mm]	B2 [mm]	d [mm]	G1	G2	H [mm]	H2 [mm]	H3 [mm]	L [mm]	X1 [mm]
VR G1/4-IG HW	40.0	60.0	40	24	G1/4"-F	G1/4"-F	109	95.7	7	50	30
VR G3/8-IG HW	76.4	87.2	49	-	G3/8"-F	G1/4"-F	177	82.3	9	76	45

# Manometers VAM

Measuring range from -1 bar to 0 bar

- Schmalz – The Company
- Vacuum Suction Cups
- Special Grippers
- Gripping Systems
- Clamping Systems
- Mounting Elements
- Vacuum Generators
- Valve Technology
- Switches and Monitoring
- Filters and Connections
- Services
- Contact
- Glossary
- Index of Products



## Suitability for Industry Specific Applications

### Applications

- Vacuum manometer for analog measurement and monitoring of vacuum values
- Universal use in vacuum systems



Manometers VAM

### Design

- Vacuum manometer VAM 67 V H-SE is a spring tube manometer
- VAM 100 V250 and VAM 63 V400 are capsule element manometers with zero adjustment
- VAM 67 V H-SE has a fixed front ring
- Vacuum connection either at the rear (-H) or the bottom (-U)

### Our Highlights...

- Conventional spring tube or capsule element vacuum manometers
- Standardized dimensions and connections
- Various measuring ranges

### Your Benefits...

- Simple and reliable; proven in many years of use
- Suitable for all existing vacuum applications
- Function is matched to customer requirements



## Designation Code Manometers VAM



#### 1 – Abbreviated designation

Code	Version
VAM	VAM

#### 2 – Diameter

Code	Diameter in mm
40...100	ø 40 to 100

#### 3 – Measuring range

Code	Measuring range in mbar
V250	-250 to 0
V400	-400 to 0
V	-1000 to 0

#### 4 – Vacuum connection

Code	Connection
H	Back
U	Bottom

#### 5 – Scale unit

Code	Unit
–	mbar
PSI	PSI

#### 6 – Design

Code	Type
SE	For panel mounting

Manometer VAM is delivered as a ready-to-connect product.

Available accessories: pressure limiter valve



# Manometers VAM



Measuring range from -1 bar to 0 bar



## Ordering Data Manometers VAM

Type	Part no.
VAM 40 V H	10.07.02.00007
VAM 40 V DR	10.07.02.00035
VAM 63 V250 H	10.07.02.00006
VAM 63 V400 H	10.07.02.00002
VAM 63 V H PSI	10.07.02.00003
VAM 63 V U PSI	10.07.02.00004
VAM 67 V H-SE	10.07.02.00016
VAM 100 V250 U	10.07.02.00001



## Ordering Data Accessories Manometers VAM

Type	Part no.
Pressure-limiter valve DBV-M G1/4-AG MS	10.05.05.00057



## Technical Data Manometers VAM

Type	Measuring range [bar]
VAM 40 V H	-1.00...0.00
VAM 40 V DR	-1.00...0.00
VAM 63 V250 H	-0.25...0.00
VAM 63 V400 H	-0.40...0.00
VAM 63 V H PSI	-1.00...0.00
VAM 63 V U PSI	-1.00...0.00
VAM 67 V H-SE	-1.00...0.00
VAM 100 V250 U	-0.25...0.00

Schmalz –  
The Company

Vacuum  
Suction Cups

Special  
Grippers

Gripping  
Systems

Clamping  
Systems

Mounting  
Elements

Vacuum  
Generators

Valve  
Technology

Switches and  
Monitoring

Filters and  
Connections

Services

Contact

Glossary

Index of  
Products



# Manometers VAM

Measuring range from -1 bar to 0 bar



## Design Data Manometers VAM

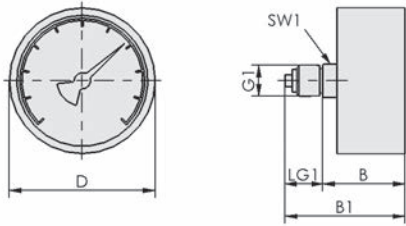

VAM 40, VAM 63H

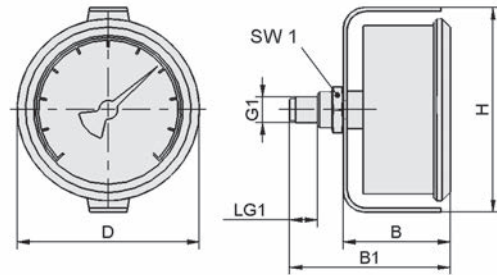

VAM 67 V H-SE

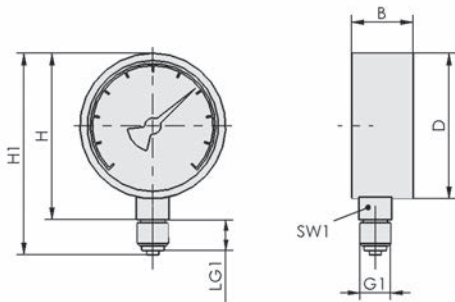

VAM 63U, VAM 100U

Type	B [mm]	B1 [mm]	D [mm]	G1	H [mm]	H1 [mm]	LG1 [mm]	SW1 [mm]
VAM 40 V H	30	40	40	G1/8"-M	-	-	10	12
VAM 40 V DR	30	40	40	G1/8"-M	-	-	9	12
VAM 63 V250 H	34	46	63	G1/4"-M	-	-	12	14
VAM 63 V400 H	34	46	63	G1/4"-M	-	-	12	14
VAM 63 V H PSI	35	48	63	G1/4"-M	-	-	13	14
VAM 63 V U PSI	26	-	63	G1/4"-M	68	82.5	13	14
VAM 67 V H-SE	40	59	67	G1/8"-M	76	-	10	14
VAM 100 V250 U	87	-	100	G1/2"-M	112	142.0	25	22



# Manometer VAM-D

Measuring range from -1 bar to 10 bar



Manometer VAM-D

## Design

- Battery powered digital manometer in a robust polycarbonate housing
- Connection of the measuring medium (vacuum and pressure) with male thread G1/8" or female thread M5
- Mounting bracket and mounting frame available as accessory for switch panel mounting
- Integrated battery indicator on the display (changeable battery)
- LCD display showing 3 ½ digits and seven segments

## Suitability for Industry Specific Applications

### Applications

- Electronic manometer with digital display for use in vacuum and pressure systems for recording and displaying of vacuum (-1 to 0 bar) and pressure (0-10 bar)
- Installation into panels due to cubic design
- Installation in handling systems directly at the site thanks to minimal size and low weight
- Ideal for mobile use (battery operated)
- Quick and easy troubleshooting in vacuum and pressure systems (optionally available in set)

### Our Highlights...

- Electronic manometer with digital display
- Compact design, very light weight (only 40 g) and battery operated
- Recording and display of vacuum or pressure values

### Your Benefits...

- Clear, visual monitoring of the system and the process
- Ideal for mobile use; no external power source required
- For universal use in vacuum and pressure systems



## Designation Code Manometer VAM-D



### 1 – Abbreviated designation

Code	Version
VAM-D	VAM-D

### 2 – Dimensions

Code	Dimensions in mm
30x30	30x30

### 3 – Measuring range

Code	Measuring range in bar
VP10	-1 to 10

### 4 – Connection

Code	Connection
G1/8-AG	G1/8-AG (AG = male (M))

### 5 – Product addition

Code	Type
SET	Set for troubleshooting

Electronic manometer VAM-D is delivered as a ready-to-connect product.

Available accessories: mounting bracket, mounting frame

Schmalz – The Company  
Vacuum Suction Cups  
Special Grippers  
Gripping Systems  
Clamping Systems  
Mounting Elements  
Vacuum Generators  
Valve Technology  
Switches and Monitoring  
Filters and Connections  
Services  
Contact  
Glossary  
Index of Products



# Manometer VAM-D

Measuring range from -1 bar to 10 bar

Schmalz – The Company  
Vacuum Suction Cups  
Special Grippers  
Gripping Systems  
Clamping Systems  
Mounting Elements  
Vacuum Generators  
Valve Technology  
Switches and Monitoring  
Filters and Connections  
Services  
Contact  
Glossary  
Index of Products

## Ordering Data Manometer VAM-D

Type*	Part no.
VAM-D 30x30 VP10 G1/8-AG	10.07.02.00055
VAM-D 30x30 VP10 G1/8-AG SET	10.07.02.00057

\*Set consists of manometer VAM-D, suitable screw in push fittings, plugs and needle probe

## Ordering Data Accessories Manometer VAM-D

Type	Part no.
Mounting bracket	BEF-WIN 13x50x31 1.6 VS
Mounting frame	EINB-RAx33.8x35.4 VS

## Technical Data Manometer VAM-D

Type	Measured medium	Measuring range [bar]	Operating temperature [°C]	Max. overpressure safety [bar]	Measured-value display	Repeatability	Weight [g]
VAM-D 30x30 VP10 G1/8-AG	Non-aggressive gases; dry, oil-free air	-1.0...10.0	0 ... 50	3	3-digit 7-segment LED	± 1% of full-scale value	40

## Design Data Manometer VAM-D

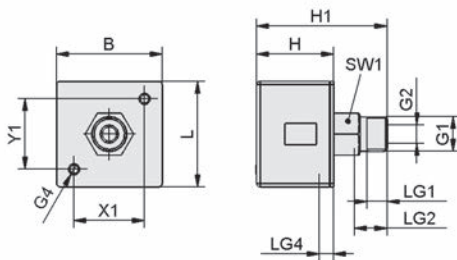

VAM-D

Type	B [mm]	G1	G2	G4	H [mm]	H1 [mm]	L [mm]	LG1 [mm]	LG2 [mm]	LG4 [mm]	SW1 [mm]	X1 [mm]	Y1 [mm]
VAM-D 30x30	30	G1/8"-M	M5-F	M3-F	22	37	30	6	9.3	4	12	20	20
VP10 G1/8-AG													

# Pressure-Reduction Valves DM

Working range from 0.5 bar to 10.0 bar



Pressure-Reduction Valves DM

## Design

- Pressure reduction valve with robust aluminum housing
- Precise pressure adjustment with lockable control handle
- Pressure gauge and bracket included with delivery

## Suitability for Industry Specific Applications

### Applications

- Pressure reduction valve for manual control of compressed air in systems
- Targeted supply of compressed air through precise pressure control, for pneumatic vacuum generators, etc.
- For use in testing and measuring applications, such as testing for leaks

## Our Highlights...

- Mechanically adjustable pressure reduction valve
- Precise control of the pressure
- Independent from primary pressure and reliable

## Your Benefits...

- Manual adjustment with very high repeatability
- Set value is maintained with high degree of accuracy
- Easy installation in any position



## Designation Code Pressure-Reduction Valves DM

DM	-	0.5...10	-	G1/2-IG
1		2		3

### 1 – Abbreviated designation

Code	Version
DM	DM

### 2 – Working area

Code	Working area in bar
0.5...10	0.5 to 10

### 3 – Connection

Code	Connection
G1/2-IG	G1/2-IG (IG = female (F))

Pressure reduction valve DM is delivered as a ready-to-connect product, including mounting bracket.

- Schmalz – The Company
- Vacuum Suction Cups
- Special Grippers
- Gripping Systems
- Clamping Systems
- Mounting Elements
- Vacuum Generators
- Valve Technology
- Switches and Monitoring
- Filters and Connections
- Services
- Contact
- Glossary
- Index of Products



# Pressure-Reduction Valves DM

Working range from 0.5 bar to 10.0 bar

## Ordering Data Pressure-Reduction Valves DM

Type	Part no.
DM 0.5...10 G1/2-IG	10.07.11.00025

## Technical Data Pressure-Reduction Valves DM

Type	Work area	Flow rate max. [l/min]*	Flow rate max. [m³/h]**	Operating temperature [°C]	Weight [kg]	Pressure max. [bar]
DM 0.5...10 G1/2-IG	0.5...10.0	1,300	78	-10 ... 60	0.74	10

\*Input pressure 10 bar and output pressure 6.3 bar  
 \*\*Input pressure 10 bar and output pressure 6.3 bar

## Design Data Pressure-Reduction Valves DM

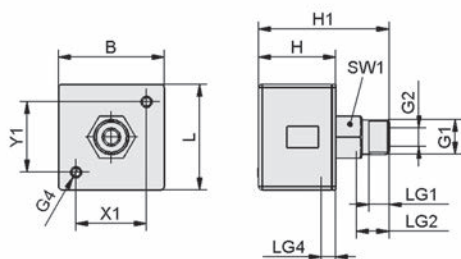

VAM-D

Type	B1 [mm]	B2 [mm]	G1	H [mm]	H2 [mm]
DM 0.5...10 G1/2-IG	96	32	G1/2"-F	136	44

Schmalz - The Company  
 Vacuum Suction Cups  
 Special Grippers  
 Gripping Systems  
 Clamping Systems  
 Mounting Elements  
 Vacuum Generators  
 Valve Technology  
 Switches and Monitoring  
 Filters and Connections  
 Services  
 Contact  
 Glossary  
 Index of Products



Schmalz –  
The Company

Vacuum  
Suction Cups

Special  
Grippers

Gripping  
Systems

Clamping  
Systems

Mounting  
Elements

Vacuum  
Generators

Valve  
Technology

**Switches and  
Monitoring**

Filters and  
Connections

Services

Contact

Glossary

Index of  
Products

# Filters and Connections



- Schmalz – The Company
- Vacuum Suction Cups
- Special Grippers
- Gripping Systems
- Clamping Systems
- Mounting Elements
- Vacuum Generators
- Valve Technology
- Switches and Monitoring
- Filters and Connections**
- Services
- Contact
- Glossary
- Index of Products



# Overview of Section

At a Glance

## Selection Aid



### Checklist for Selection of Filters

Page

637

## Vacuum Filters



### Vacuum Filters VF / STF / STF-D

- Nominal flow rates: 6 m<sup>3</sup>/h to 480 m<sup>3</sup>/h
- Pore sizes: 3 to 10 µm



Vacuum filter for use in very dusty environments with a degree of separation of almost 100 %; protection of the vacuum generator.

638



### Vacuum Cup Filters VFT

- Pore size: 80 and 100 µm
- Connection thread: G1/8" to G3/4"
- Material: PE and stainless steel
- Nominal flow rate: 45 to 770 l/min



Vacuum cup filter for central integration in vacuum systems with light to medium degrees of contamination for protection of the vacuum generator.

641



### Inline Filters VFI

- Nominal flow rates: 2 to 4 m<sup>3</sup>/h
- Filter mesh: 50 µm
- Connection options: hose 4/2, 6/4 or 8/6



Inline filter, installation directly on the suction cup, in vacuum systems with light to medium degrees of contamination to protect the vacuum generator.

644

## Vacuum Distributors



### Vacuum / Compressed Air Distributors VTR

- 5-way and 9-way manifolds
- Connections: G1/8" and G1/4"



Distributor for vacuum supply of several suction cups for central vacuum generation.











647



# Overview of Section

At a Glance

## Hoses and Connectors

		Page
Vacuum Suction Cups	 <p><b>Vacuum / Compressed Air Hoses VSL</b></p> <ul style="list-style-type: none"> <li>External/internal diameters from 4/2 to 87/75</li> <li>Materials: PA, PE, PU, PVC</li> </ul>	 <p>Vacuum / compressed air hose made from PA, PE, PU or PVC, optionally reinforced with hard PVC spirals, wire spirals or fabric lining.</p> <p style="text-align: right;">649</p>
Special Grippers	 <p><b>Hose Clamps SSB / SSD</b></p> <ul style="list-style-type: none"> <li>Clamping diameters 10 to 90 mm</li> </ul>	 <p>Hose clamps with stable threaded spindle for securing smooth or wire-reinforced hose lines on hose nozzles.</p> <p style="text-align: right;">653</p>
Gripping Systems	 <p><b>Screw in Push Fittings</b></p> <ul style="list-style-type: none"> <li>Connection thread M5 to G1/2"</li> <li>Material: nickel-plated brass</li> </ul>	 <p>Screw in push fittings for quick, tool-free connection of hoses.</p> <p style="text-align: right;">656</p>
Clamping Systems	 <p><b>Accessories for Screw Unions</b></p> <ul style="list-style-type: none"> <li>Connection thread M5 to G1-1/2"</li> <li>Material: nickel-plated brass</li> </ul>	 <p>Accessories for screw fittings for closing, reducing, enlarging and extending threaded holes.</p> <p style="text-align: right;">662</p>
Mounting Elements	 <p><b>Sealing Rings DR</b></p> <ul style="list-style-type: none"> <li>Internal diameters: 3.5 to 48 mm</li> <li>Material: PA</li> </ul>	 <p>Sealing rings for sealing of connection nipples and other connection elements.</p> <p style="text-align: right;">667</p>
Vacuum Generators		
Valve Technology		
Switches and Monitoring		

Schmalz – The Company

Vacuum Suction Cups

Special Grippers

Gripping Systems

Clamping Systems

Mounting Elements

Vacuum Generators

Valve Technology

Switches and Monitoring

Filters and Connections

Services

Contact

Glossary

Index of Products

**Overview Flow Resistance in Hoses**

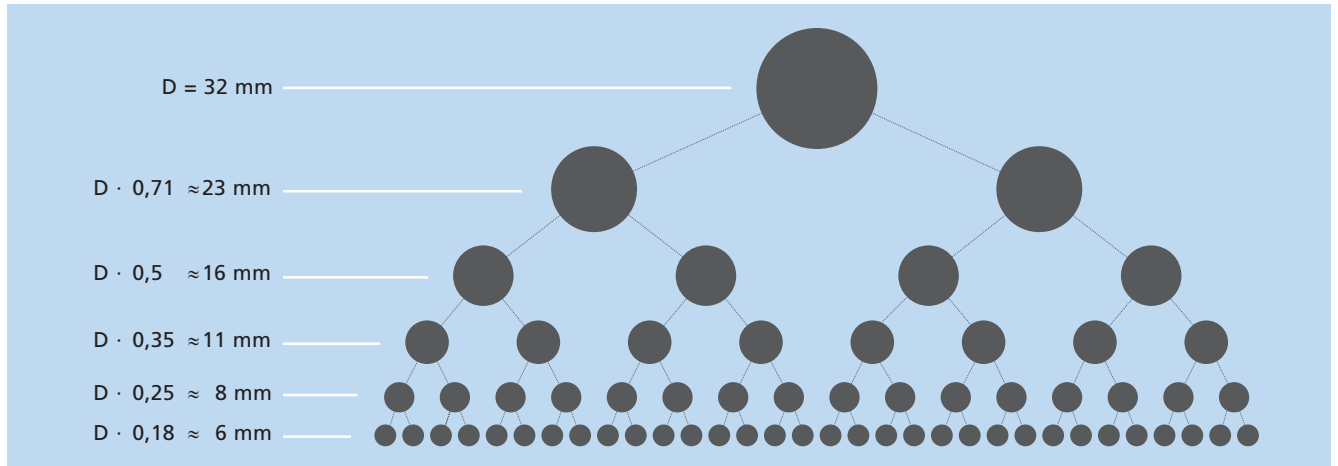

**Aid for the dimensioning of distribution hoses:**

Example: A hose with an internal diameter  $D = 32$  mm has the same internal flow rate as 32 hoses with an internal diameter of 6 mm or 4 hoses with an internal diameter of 16 mm.

**Checklist for Selection of Hoses**

Criterion/material	PVC	PU	PE	PA
Resistance to oil	Good	Excellent	Good	Very good
Resistance to fuels and natural gases	Medium	Very good	Medium	Good
Resistance to weathering	Medium	Excellent	Medium	Medium
Behaviour at low temperatures	Freezes at $-20^{\circ}$ C	Similar to a hard plastic at $-35$ to $-40^{\circ}$ C, but no embrittlement	Freezes at $-50^{\circ}$ C	Freezes at $-40^{\circ}$ C
Behaviour at high temperatures	Withstands $70^{\circ}$ C for long periods	Withstands $80^{\circ}$ C for long periods, for short periods up to $100^{\circ}$ C	Withstands $70^{\circ}$ C for long periods	Withstands $85^{\circ}$ C for long periods
Dynamic stress resistance	Tensile strength: good; Ductile yield: very good; suitable for static installation	Tensile strength: excellent Ductile yield: excellent, very high elasticity, excellent creepage resistance, thus suitable for trailing cable installations	Tensile strength: very good Ductile yield: very good, suitable for static installation	Tensile strength: very good Ductile yield: good, suitable for static installation
Resistance to abrasion	Good	Excellent	Good	Good

# Vacuum Filters VF / STF / STF-D

Rated flow from 100 l/min to 8,000 l/min

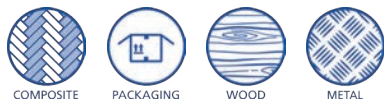

## Suitability for Industry Specific Applications

### Applications

- Vacuum filter for protection of sensitive vacuum generators (such as pumps and blowers) by filtering the incoming air
- For use in dusty surroundings; removal of almost 100 % of the dust and dirt



Vacuum Filters VF / STF / STF-D

### Design

- Vacuum filter type VF: aluminum filter house, cover screwed on, filter cartridge with wire mesh or paper filter
- Vacuum filter type STF N: sheet steel filter housing, cover clipped on, filter cartridge with special paper filter
- Vacuum filter types STF P: plastic filter housing, cover clipped on, with mounting bracket, filter cartridge with special paper filter, large connections
- Type STF-D P: with additional pressure monitor for measuring the degree of contamination

### Our Highlights...

- Wide range of sizes with various performance figures
- Replaceable filter cartridges
- Filter elements with almost 100 % removal of dust and dirt
- Optionally with monitoring of the degree of contamination of the filter cartridge

### Your Benefits...

- The right filter for each vacuum generator
- Low operating costs, environmentally friendly design
- Optimum protection of vacuum generators against dust and dirt
- Maximum system availability



## Ordering Data Vacuum Filters VF / STF / STF-D

Type*	Part no.
VF-6 G1/4-IG 15	10.07.01.00003
VF-10 G3/8-IG 10	10.07.01.00004
STF G3/4-IG N	10.07.01.00007
STF G1-1/4-IG N	10.07.01.00008
STF G2-1/2-IG N	10.07.01.00010
STF 60 P 4.5 SSD	10.07.01.00259
STF 60 P 6.0 SSD	10.07.01.00260
STF 75 P 8.0 SSD	10.07.01.00263
STF-D 60 P 4.5 F SSD	10.07.01.00266
STF-D 60 P 6.0 F SSD	10.07.01.00262
STF-D 75 P 8.0 F SSD	10.07.01.00265

\*STF-D: incl. differential pressure monitor to control the filter

Schmalz - The Company  
Vacuum Suction Cups  
Special Grippers  
Gripping Systems  
Clamping Systems  
Mounting Elements  
Vacuum Generators  
Valve Technology  
Switches and Monitoring  
Filters and Connections  
Services  
Contact  
Glossary  
Index of Products

# Vacuum Filters VF / STF / STF-D

Rated flow from 100 l/min to 8,000 l/min



## Ordering Data Spare Parts Vacuum Filters VF / STF / STF-D

Type	Spare Parts		Part no.
VF-6 G1/4-IG 15	Filter insert (round)	FILT-EINS 15 27x23 A2 VF-1/4-Draht	10.07.01.00013
VF-10 G3/8-IG 10	Filter insert (round)	FILT-EINS 10 28x51 PAP VF-3/8	10.07.01.00014
STF G3/4-IG N	Filter insert (round)	FILT-EINS 3 65x70 PAP STF-3/4-IG	10.07.01.00017
STF G1-1/4-IG N	Filter insert (round)	FILT-EINS 3 98x70 PAP STF-1-1/4-IGN	10.07.01.00018
STF G2-1/2-IG N	Filter insert (round)	FILT-EINS 3 150x222 PAP STF-2-1/2-IG	10.07.01.00020
STF 60 P 4.5 SSD	Filter insert (round)	FILT-EINS 3 124x320 PAP STF-Picl-4.5	10.07.01.00060
STF 60 P 6.0 SSD	Filter insert (round)	FILT-EINS 3 149x361 PAP STF-Picl-6	10.07.01.00054
STF 75 P 8.0 SSD	Filter insert (round)	FILT-EINS 3 159x376 STF-Picl-8	10.07.01.00079
STF-D 60 P 4.5 F SSD	Filter insert (round)	FILT-EINS 3 124x320 PAP STF-Picl-4.5	10.07.01.00060
STF-D 60 P 6.0 F SSD	Filter insert (round)	FILT-EINS 3 149x361 PAP STF-Picl-6	10.07.01.00054
STF-D 75 P 8.0 F SSD	Filter insert (round)	FILT-EINS 3 159x376 STF-Picl-8	10.07.01.00079



## Ordering Data Accessories Vacuum Filters VF / STF / STF-D

Type	Accessories	Part no.
VF-6 G1/4-IG 15	Mounting bracket	BEF-WIN 42x36x48 2 PVT-PVS
VF-10 G3/8-IG 10	Mounting bracket	BEF-WIN 42x36x48 2 PVT-PVS



## Technical Data Vacuum Filters VF / STF / STF-D

Type	Filter pore size [μm]	Nominal flow rate [l/min]	Nominal flow rate [m <sup>3</sup> /h]	Max. vacuum [mbar]	Overpressure (max.) at 25° C [bar]	Weight [kg]
VF-6 G1/4-IG 15	15	100	6	-950	6.0	0.13
VF-10 G3/8-IG 10	10	166	10	-950	6.0	0.22
STF G3/4-IG N	3	700	42	-950	1.0	0.50
STF G1-1/4-IG N	3	1,600	96	-950	1.0	1.00
STF G2-1/2-IG N	3	6,000	360	-950	1.0	4.30
STF 60 P 4.5 SSD	3	4,500	270	-500	0.3	2.00
STF 60 P 6.0 SSD	3	6,000	360	-500	0.3	2.40
STF 75 P 8.0 SSD	3	8,000	480	-500	0.3	2.60
STF-D 60 P 4.5 F SSD	3	4,500	270	-500	0.3	2.10
STF-D 60 P 6.0 F SSD	3	6,000	360	-500	0.3	2.40
STF-D 75 P 8.0 F SSD	3	8,000	480	-500	0.3	2.60

# Vacuum Filters VF / STF / STF-D

Rated flow from 100 l/min to 8,000 l/min

## Design Data Vacuum Filters VF / STF / STF-D

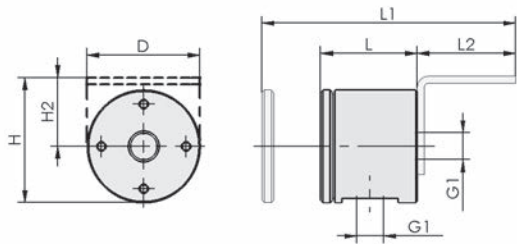

VF

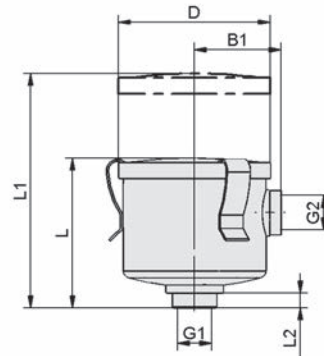

STF G3/4, STF G1-1/4, STF G2-1/2

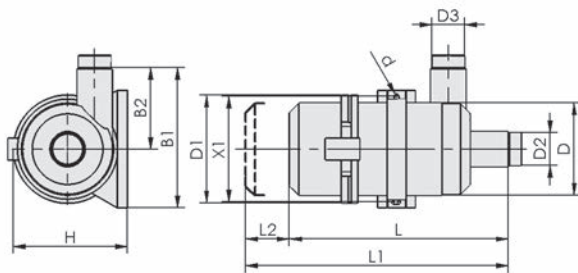

STF 60, STF 75

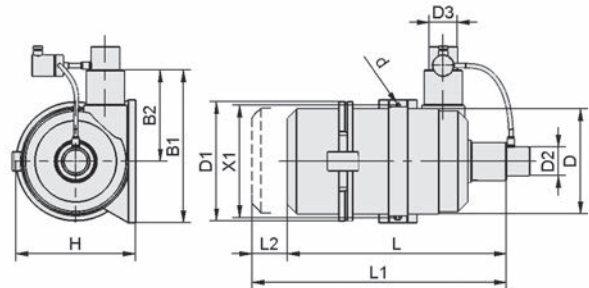

STF-D

## Design Data Vacuum Filters VF / STF / STF-D

Type	B1 [mm]	B2 [mm]	d [mm]	D [mm]	D1 [mm]	D2 [mm]	D3 [mm]	G1	G2	H [mm]	H2 [mm]	L [mm]	L1 [mm]	L2 [mm]	X1 [mm]
VF-6 G1/4-IG 15	-	-	-	48	-	-	-	G1/4"-F	-	54	30	41	108	42	-
VF-10 G3/8-IG 10	-	-	-	48	-	-	-	G3/8"-F	-	54	30	70	157	42	-
STF G3/4-IG N	59	-	-	97	-	-	-	G3/4"-F	G3/4"-F	-	-	89	159	6	-
STF G1-1/4-IG N	81	-	-	136	-	-	-	G1-1/4"-F	G1-1/4"-F	-	-	116	191	17	-
STF G2-1/2-IG N	123	-	-	200	-	-	-	G2-1/2"-F	G2-1/2"-F	-	-	250	490	12	-
STF 60 P 4.5 SSD	221	112	9	170	198	60	60	-	-	218	-	355	658	303	192
STF 60 P 6.0 SSD	265	142	9	200	229	60	60	-	-	253	-	390	741	351	220
STF 75 P 8.0 SSD	280	148	9	228	248	75	75	-	-	260	-	415	774	359	237
STF-D 60 P 4.5 F SSD	221	112	9	170	198	60	60	-	-	218	-	355	658	303	192
STF-D 60 P 6.0 F SSD	265	142	9	200	229	60	60	-	-	253	-	390	741	351	220
STF-D 75 P 8.0 F SSD	280	148	9	228	248	75	75	-	-	260	-	415	774	359	237

Schmalz - The Company  
Vacuum Suction Cups  
Special Grippers  
Gripping Systems  
Clamping Systems  
Mounting Elements  
Vacuum Generators  
Valve Technology  
Switches and Monitoring  
Filters and Connections  
Services  
Contact  
Glossary  
Index of Products



# Vacuum Cup Filters VFT

Rated flow from 45 l/min to 770 l/min



Vacuum Cup Filters VFT

## Design

- Vacuum cup filter with filter cup made of clear nylon
- Filter cartridge made of polyethylene (pore size 80 µm) or stainless steel (pore size 100 µm)
- Stainless steel cartridge can be cleaned and reused several times

## Suitability for Industry Specific Applications

### Applications

- Vacuum cup filter for protection of easily damaged vacuum generators (such as pumps and blowers) by filtering the incoming air
- Filtering of vacuum and compressed air at pressures up to 7 bar
- Filtering light to medium contaminated air with pore size 80 µm
- Filtering heavy contaminated air with pore size 100 µm

### Our Highlights...

- Wide range of sizes
- Filter elements with very good separation
- Filter pore sizes 80 and 100 µm
- Filter elements made of stainless steel (100 µm) and polyethylene (80 µm)

### Your Benefits...

- Suitable filter for all vacuum generators
- Optimum protection of vacuum generators against dust and dirt
- Ideal for use as pre-filters and fine filters for air with varying degrees of contamination
- Long-life filter elements which can be cleaned and reused



## Designation Code Vacuum Cup Filters VFT

VFT	-	G1/8-IG	-	80
1		2		3

### 1 – Abbreviated designation

Code	Version
VFT	VFT

### 2 – Connection

Code	Connection
G1/8-IG	G1/8-IG (IG = female (F))
G1/4-IG	G1/4-IG
G3/8-IG	G3/8-IG
G1/2-IG	G1/2-IG
G3/4-IG	G3/4-IG

### 3 – Filter fineness

Code	Filter fineness in µm
80...100	80 and 100

Vacuum filter VFT is delivered as a ready-to-connect product.

Available spare parts: filter cartridge (filter insert)  
Available accessories: filter holder



Schmalz – The Company  
Vacuum Suction Cups  
Special Grippers  
Gripping Systems  
Clamping Systems  
Mounting Elements  
Vacuum Generators  
Valve Technology  
Switches and Monitoring  
Filters and Connections  
Services  
Contact  
Glossary  
Index of Products

# Vacuum Cup Filters VFT

Rated flow from 45 l/min to 770 l/min



## Ordering Data Vacuum Cup Filters VFT

Type	Part no.
VFT G1/8-IG 80	10.07.01.00116
VFT G1/8-IG 100	10.07.01.00117
VFT G1/4-IG 80	10.07.01.00119
VFT G1/4-IG 100	10.07.01.00120
VFT G3/8-IG 80	10.07.01.00122
VFT G3/8-IG 100	10.07.01.00123
VFT G1/2-IG 80	10.07.01.00125
VFT G1/2-IG 100	10.07.01.00126
VFT G3/4-IG 80	10.07.01.00128
VFT G3/4-IG 100	10.07.01.00129



## Ordering Data Spare Parts Vacuum Cup Filters VFT

Type	Spare Parts	Part no.
VFT G1/8-IG 80	Filter insert (round)    FILT-EINS 80 25x37 PE VFT-1/8-1/4	10.07.01.00141
VFT G1/8-IG 100	Filter insert (round)    FILT-EINS 100 25x37 A2 VFT-1/8+1/4	10.07.01.00132
VFT G1/4-IG 80	Filter insert (round)    FILT-EINS 80 25x37 PE VFT-1/8-1/4	10.07.01.00141
VFT G1/4-IG 100	Filter insert (round)    FILT-EINS 100 25x37 A2 VFT-1/8+1/4	10.07.01.00132
VFT G3/8-IG 80	Filter insert (round)    FILT-EINS 80 25x71 PE VFT-3/8-1/2	10.07.01.00143
VFT G3/8-IG 100	Filter insert (round)    FILT-EINS 100 25x71 A2 VFT-3/8+1/2	10.07.01.00135
VFT G1/2-IG 80	Filter insert (round)    FILT-EINS 80 25x71 PE VFT-3/8-1/2	10.07.01.00143
VFT G1/2-IG 100	Filter insert (round)    FILT-EINS 100 25x71 A2 VFT-3/8+1/2	10.07.01.00135
VFT G3/4-IG 80	Filter insert (round)    FILT-EINS 80 39x89 PE VFT-3/4	10.07.01.00145
VFT G3/4-IG 100	Filter insert (round)    FILT-EINS 100 39x89 A2 VFT-3/4	10.07.01.00138



## Ordering Data Accessories Vacuum Cup Filters VFT

Type	Accessories	Part no.
VFT G1/8-IG 80	Filter holder    HTR-FIL 25 WI VFT1/8-1/2	10.07.01.00228
VFT G1/8-IG 100	Filter holder    HTR-FIL 25 WI VFT1/8-1/2	10.07.01.00228
VFT G1/4-IG 80	Filter holder    HTR-FIL 25 WI VFT1/8-1/2	10.07.01.00228
VFT G1/4-IG 100	Filter holder    HTR-FIL 25 WI VFT1/8-1/2	10.07.01.00228
VFT G3/8-IG 80	Filter holder    HTR-FIL 25 WI VFT1/8-1/2	10.07.01.00228
VFT G3/8-IG 100	Filter holder    HTR-FIL 25 WI VFT1/8-1/2	10.07.01.00228
VFT G1/2-IG 80	Filter holder    HTR-FIL 25 WI VFT1/8-1/2	10.07.01.00228
VFT G1/2-IG 100	Filter holder    HTR-FIL 25 WI VFT1/8-1/2	10.07.01.00228
VFT G3/4-IG 80	Filter holder    HTR-FIL 25 WI VFT3/4	10.07.01.00229
VFT G3/4-IG 100	Filter holder    HTR-FIL 25 WI VFT3/4	10.07.01.00229

# Vacuum Cup Filters VFT

Rated flow from 45 l/min to 770 l/min

## Technical Data Vacuum Cup Filters VFT

Type	Filter pore size [μm]	Nominal flow rate [l/min]	Nominal flow rate [m³/h]	Max. vacuum [mbar]	Overpressure (max.) at 25° C [bar]	Overpressure (max.) at 50° C [bar]	Weight [g]
VFT G1/8-IG 80	80	45	2.7	-990	7	5	49
VFT G1/8-IG 100	100	50	3.0	-990	7	5	49
VFT G1/4-IG 80	80	110	6.6	-990	7	5	47
VFT G1/4-IG 100	100	140	8.4	-990	7	5	47
VFT G3/8-IG 80	80	245	14.7	-990	7	5	79
VFT G3/8-IG 100	100	290	17.4	-990	7	5	79
VFT G1/2-IG 80	80	300	18.0	-990	7	5	76
VFT G1/2-IG 100	100	320	19.2	-990	7	5	76
VFT G3/4-IG 80	80	600	36.0	-990	7	5	164
VFT G3/4-IG 100	100	770	46.2	-990	7	5	164

## Design Data Vacuum Cup Filters VFT

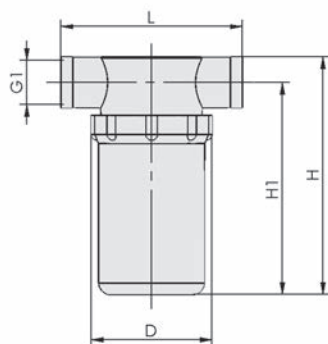

VFT

Type	D [mm]	G1	H [mm]	H1 [mm]	L [mm]
VFT G1/8-IG 80	48.0	G1/8"-F	60	50	76
VFT G1/8-IG 100	48.0	G1/8"-F	60	50	76
VFT G1/4-IG 80	48.0	G1/4"-F	60	50	76
VFT G1/4-IG 100	48.0	G1/4"-F	60	50	76
VFT G3/8-IG 80	48.5	G3/8"-F	101	88	78
VFT G3/8-IG 100	48.5	G3/8"-F	101	88	78
VFT G1/2-IG 80	48.0	G1/2"-F	101	88	78
VFT G1/2-IG 100	48.5	G1/2"-F	101	88	78
VFT G3/4-IG 80	75.0	G3/4"-F	137	118	91
VFT G3/4-IG 100	75.0	G3/4"-F	137	118	91

# Inline Filters VFI

Rated flow from 32 l/min to 66 l/min



## Suitability for Industry Specific Applications

### Applications

- Inline filter for use in vacuum systems with light to medium dirt levels
- Can be mounted on individual suction cups for the handling of dirty workpieces
- Simple hose connection



Inline Filters VFI

### Design

- Nozzles with union nuts (1) on both ends for connection of hoses (internal hose diameter 4 and 6 mm); alternatively available with a push-in hose connection
- Transparent filter housing with arrow for indication of the flow direction (3)
- Filter head with knurled screw cap
- Slide-in filter element (2) made of transparent material for visual monitoring

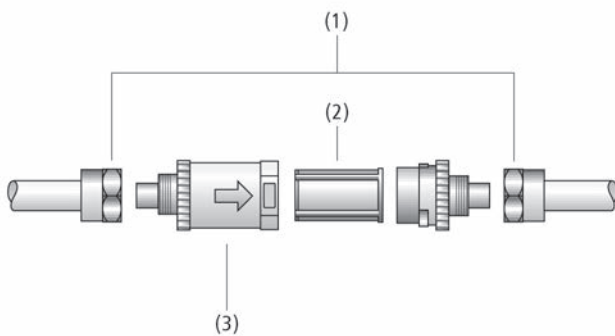

System Design Inline Filters VFI



Mounting example inline filters VFI

### Our Highlights...

- Fast and easily replaceable filter insert
- Indication of degree of contamination through transparent housing
- Simple hose connection
- Vacuum filter capable of withstanding short-term pressures of up to 7 bar

### Your Benefits...

- Low operating costs, environmentally friendly product
- Fast identification allows efficient maintenance
- Quick installation
- Suitable for universal use in systems with vacuum and pressure

- Schmalz – The Company
- Vacuum Suction Cups
- Special Grippers
- Gripping Systems
- Clamping Systems
- Mounting Elements
- Vacuum Generators
- Valve Technology
- Switches and Monitoring
- Filters and Connections
- Services
- Contact
- Glossary
- Index of Products

# Inline Filters VFI

Rated flow from 32 l/min to 66 l/min



## Designation Code Inline Filters VFI

<b>VFI</b>	-	<b>CN6/4</b>	-	<b>50</b>
1		2		3

### 1 – Abbreviated designation

Code	Version
VFI	VFI

### 2 – Diameter

Code	Diameter in mm
CN6/4	∅ CN6/4 (outside / inside)
CN8/6	∅ CN8/6 (outside / inside)
4/2	Quick action push-in coupling (∅ 4/2)
6/4	Quick action push-in coupling (∅ 6/4)

### 3 – Filter fineness

Code	Filter fineness in µm
50	50

Inline filter VFI is delivered as a ready-to-connect product.

Available spare parts: filter cartridge (filter insert)



## Ordering Data Inline Filters VFI

Type	Part no.
VFI CN6/4 50	10.07.01.00241
VFI CN8/6 50	10.07.01.00245
VFI 4/2 50	10.07.01.00329
VFI 6/4 50	10.07.01.00328



## Ordering Data Spare Parts Inline Filters VFI

Type*	Spare Parts	Part no.
VFI CN6/4 50	Filter insert (round)	FILT-EINS 50 10x21 VFI 10.07.01.00244
VFI CN8/6 50	Filter insert (round)	FILT-EINS 50 16x23 VFI 10.07.01.00248
VFI 4/2 50	Filter insert (round)	FILT-EINS 50 10x21 VFI 10.07.01.00244
VFI 6/4 50	Filter insert (round)	FILT-EINS 50 16x23 VFI 10.07.01.00248

\*Packaging unit: 5 pieces



## Technical Data Inline Filters VFI

Type	Filter pore size [µm]	Nominal flow rate [l/min]*	Nominal flow rate [m³/h]**	Max. vacuum [mbar]	Overpressure (max.) at 25° C [bar]	Overpressure (max.) at 50° C [bar]	Weight [g]
VFI CN6/4 50	50	32	1.92	-990	7	5	6
VFI CN8/6 50	50	66	3.96	-990	7	5	10
VFI 4/2 50	50	32	1.92	-990	7	5	6
VFI 6/4 50	50	66	3.96	-990	7	5	17

\*In the case of a pressure drop of max. 40 mbar while gripping

\*\*In the case of a pressure drop of max. 40 mbar while gripping

# Inline Filters VFI

Rated flow from 32 l/min to 66 l/min



## Design Data Inline Filters VFI

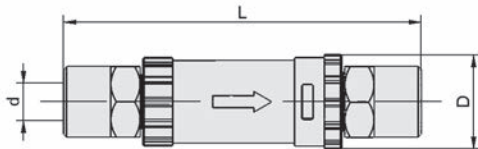

VFI CN

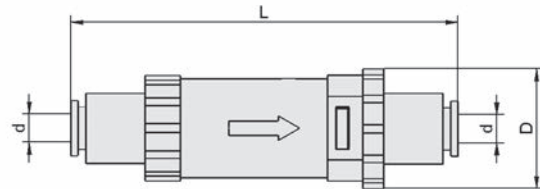

VFI

Type	d [mm]	D [mm]	L [mm]
VFI CN6/4 50	6	16	61
VFI CN8/6 50	8	23	68
VFI 4/2 50	4	17	55
VFI 6/4 50	6	25	69

- Schmalz – The Company
- Vacuum Suction Cups
- Special Grippers
- Gripping Systems
- Clamping Systems
- Mounting Elements
- Vacuum Generators
- Valve Technology
- Switches and Monitoring
- Filters and Connections
- Services
- Contact
- Glossary
- Index of Products



# Vacuum / Compressed Air Distributors VTR

Number of threads from 5 to 9



## Suitability for Industry Specific Applications



Vacuum / Compressed Air Distributors VTR

### Applications

- Distribution of vacuum in systems with a central vacuum generator and several suction cups
- Distribution of compressed air in systems with several distributed vacuum generators

### Design

- Distributor made of high strength aluminum with mounting holes

### Our Highlights...

- Large cross sections and matched inlets and outlets
- Two different sizes available
- Sizes matched to other accessories

### Your Benefits...

- Reduces and optimizes the flow resistance
- Permits optimisation for fast evacuation times and low flow resistance
- The ideal solution for a complete installation



## Designation Code Vacuum / Compressed Air Distributors VTR

VTR	-	G1/4-IG	-	5x	-	G1/8-IG
1		2		3		4

#### 1 – Abbreviated designation

Code	Version
VTR	VTR

#### 2 – Connection 1

Code	Connection
G1/4-IG	G1/4-IG (IG = female (F))
G3/8-IG	G3/8-IG

#### 3 – Number of threads

Code	Number
5x...9x	5x and 9x

#### 4 – Connection 2

Code	Connection
G1/8-IG	G1/8-IG (IG = female (F))
G1/4-IG	G1/4-IG

Vacuum / compressed air distributor VTR is delivered as a ready-to-connect product.



Schmalz – The Company  
Vacuum Suction Cups  
Special Grippers  
Gripping Systems  
Clamping Systems  
Mounting Elements  
Vacuum Generators  
Valve Technology  
Switches and Monitoring  
Filters and Connections  
Services  
Contact  
Glossary  
Index of Products

# Vacuum / Compressed Air Distributors VTR

Number of threads from 5 to 9



## Ordering Data Vacuum / Compressed Air Distributors VTR

Type	Part no.
VTR G1/4-IG 5xG1/8	10.09.03.00058
VTR G3/8-IG 5xG1/4	10.09.03.00060
VTR G1/4-IG 9xG1/8	10.09.03.00056
VTR G3/8-IG 9xG1/4	10.09.03.00054



## Technical Data Vacuum / Compressed Air Distributors VTR

Type	Distribution type	Weight [g]
VTR G1/4-IG 5xG1/8	5 x thread G1/8"-F	90
VTR G3/8-IG 5xG1/4	5 x thread G1/4"-F	110
VTR G1/4-IG 9xG1/8	9 x thread G1/8"-F	120
VTR G3/8-IG 9xG1/4	9 x thread G1/4"-F	240



## Design Data Vacuum / Compressed Air Distributors VTR

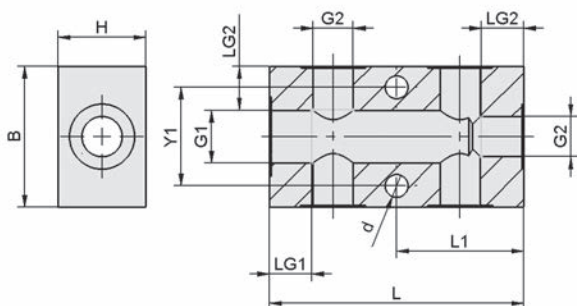

VTR 5

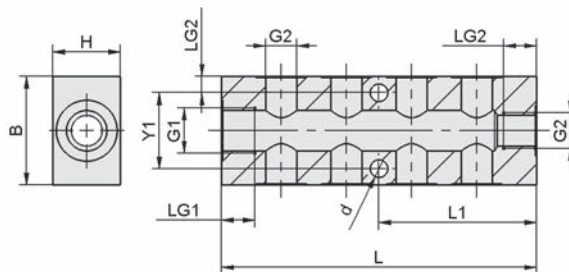

VTR 9

Type	B [mm]	d [mm]	G1	G2	H [mm]	L [mm]	L1 [mm]	LG1 [mm]	LG2 [mm]	Y1 [mm]
VTR G1/4-IG 5xG1/8	35	6.5	G1/4"-F	G1/8"-F	20	60	30	10	9	22
VTR G3/8-IG 5xG1/4	40	6.5	G3/8"-F	G1/4"-F	25	72	36	13	11	27
VTR G1/4-IG 9xG1/8	35	6.5	G1/4"-F	G1/8"-F	20	90	45	13	9	22
VTR G3/8-IG 9xG1/4	40	6.5	G3/8"-F	G1/4"-F	25	116	58	13	11	27



Schmalz - The Company  
Vacuum Suction Cups  
Special Grippers  
Gripping Systems  
Clamping Systems  
Mounting Elements  
Vacuum Generators  
Valve Technology  
Switches and Monitoring  
Filters and Connections  
Services  
Contact  
Glossary  
Index of Products



# Vacuum / Compressed Air Hoses VSL

Material PA, PE, PU, PVC



## Suitability for Industry Specific Applications



Vacuum / Compressed Air Hoses VSL

### Applications

- Hose connections in vacuum systems
- Polyurethane (PU) hoses for energy distribution systems

### Design

- Vacuum hoses made of PVC, PU, PA and PE, some in the form of a hard PVC spiral (PS), with a wire spiral (DS) or a textile layer (G)

### Our Highlights...

- Vacuum hoses with internal diameters from 2 to 75 mm
- Wide range of materials

### Your Benefits...

- Wide range of sizes permits optimization for best evacuation time and flow resistance
- Suitable hoses for all applications



## Designation Code Vacuum / Compressed Air Hoses VSL



#### 1 – Abbreviated designation

Code	Version
VSL	VSL

#### 4 – Product addition

Code	Type
DS	Wire spiral
G	Textile layer
PS	PVC spiral

#### 2 – Diameter

Code	Diameter in mm
4-2...87-75	ø 4-2 to 87-75 (outside-inside)

#### 3 – Material

Code	Material
PA	Polyamide
PE	Polyethylene
PU	Polyurethane
PVC	Polyvinyl chloride

Vacuum/compressed air hose VSL is delivered in the desired length.

Available accessories: hose clamp

# Vacuum / Compressed Air Hoses VSL

Material PA, PE, PU, PVC



## Ordering Data Vacuum / Compressed Air Hoses VSL

Type	Part no.	Accessories		Part no.
VSL 4-2 PE	10.07.09.00013	-	-	-
VSL 4-2 PU	10.07.09.00001	-	-	-
VSL 4-2.7 PA	10.07.09.00063	-	-	-
VSL 6-4 PE	10.07.09.00014	-	-	-
VSL 6-4 PU	10.07.09.00002	-	-	-
VSL 8-6 PE	10.07.09.00015	-	-	-
VSL 8-6 PU	10.07.09.00003	-	-	-
VSL 10-7 PE	10.07.09.00083	Hose clamp	SSB 10-16 ST-VZ	10.07.10.00001
VSL 10-7 PU	10.07.09.00084	Hose clamp	SSB 10-16 ST-VZ	10.07.10.00001
VSL 12-9 PE	10.07.09.00050	Hose clamp	SSB 10-16 ST-VZ	10.07.10.00001
VSL 12-9 PU	10.07.09.00037	Hose clamp	SSB 10-16 ST-VZ	10.07.10.00001
VSL 14-11 PU	10.07.09.00038	Hose clamp	SSB 10-16 ST-VZ	10.07.10.00001
VSL 15-9 PVC-G	10.07.09.00005	Hose clamp	SSB 10-16 ST-VZ	10.07.10.00001
VSL 18-12 PVC-DS	10.07.09.00016	Hose clamp	SSB 16-27 ST-VZ	10.07.10.00002
VSL 21-12 PVC-G	10.07.09.00006	Hose clamp	SSB 20-32 ST-VZ	10.07.10.00003
VSL 26-19 PVC-DS	10.07.09.00007	Hose clamp	SSB 20-32 ST-VZ	10.07.10.00003
VSL 27-20 PU-DS	10.07.09.00047	Hose clamp	SSD 20-25	10.07.10.00071
VSL 33-25 PVC-DS	10.07.09.00041	Hose clamp	SSB 32-50 ST-VZ	10.07.10.00004
VSL 33-25 PU-DS	10.07.09.00051	Hose clamp	SSD 28-32 ST-VZ	10.07.10.00087
VSL 41-32 PVC-DS	10.07.09.00008	Hose clamp	SSB 32-50 ST-VZ	10.07.10.00004
VSL 42-32 PU-DS	10.07.09.00036	Hose clamp	SSD 38-43 ST-VZ	10.07.10.00019
VSL 41-35 PVC-PS	10.07.09.00010	Hose clamp	SSD 38-43 ST-VZ	10.07.10.00019
VSL 44-38 PU-DS	10.07.09.00031	Hose clamp	SSD 38-43 ST-VZ	10.07.10.00019
VSL 47-38 PU-DS	10.07.09.00052	Hose clamp	SSD 43-49 ST-VZ	10.07.10.00020
VSL 48-38 PVC-DS	10.07.09.00009	Hose clamp	SSB 32-50 ST-VZ	10.07.10.00004
VSL 48-40 PVC-PS	10.07.09.00011	Hose clamp	SSD 43-49 ST-VZ	10.07.10.00020
VSL 60-50 PU-DS	10.07.09.00020	Hose clamp	SSD 54-60 ST-VZ	10.07.10.00036
VSL 60-50 HV PU-DS	10.07.09.00076	Hose clamp	SSD 54-60 ST-VZ	10.07.10.00036
VSL 61-50 PVC-DS	10.07.09.00033	Hose clamp	SSD 54-60 ST-VZ	10.07.10.00036
VSL 71-60 PVC-DS	10.07.09.00012	Hose clamp	SSD 64-70 A2	10.07.10.00098
VSL 71-60 PU-DS	10.07.09.00034	Hose clamp	SSD 64-70 A2	10.07.10.00098
VSL 71-60 PU-DS	10.07.09.00065	Hose clamp	SSD 64-70 A2	10.07.10.00098
VSL 85-75 PVC-PS	10.07.09.00048	Hose clamp	SSD 85-90 ST-VZ	10.07.10.00102
VSL 85-75 PU-DS	10.07.09.00054	Hose clamp	SSD 85-90 ST-VZ	10.07.10.00102
VSL 87-75 PU-DS	10.07.09.00061	Hose clamp	SSD 85-90 ST-VZ	10.07.10.00102

Schmalz –  
The CompanyVacuum  
Suction CupsSpecial  
GrippersGripping  
SystemsClamping  
SystemsMounting  
ElementsVacuum  
GeneratorsValve  
TechnologySwitches and  
MonitoringFilters and  
Connections

Services

Contact

Glossary

Index of  
Products

# Vacuum / Compressed Air Hoses VSL

Material PA, PE, PU, PVC



## Technical Data Vacuum / Compressed Air Hoses VSL

Type	Material hose	Pressure range (operating pressure) [bar]*	Operating temperature [°C]	Bending radius min. [mm]**	Length max. [m]***
VSL 4-2 PE	PE	-0.95 ... 10.00	-30 ... 70	20	100
VSL 4-2 PU	PU	-0.95 ... 10.00	-40 ... 60	20	50
VSL 4-2.7 PA	PA	-0.95 ... 20.00	-40 ... 90	30	50
VSL 6-4 PE	PE	-0.95 ... 10.00	-30 ... 70	35	100
VSL 6-4 PU	PU	-0.95 ... 10.00	-20 ... 90	35	500
VSL 8-6 PE	PE	-0.95 ... 10.00	-30 ... 70	45	100
VSL 8-6 PU	PU	-0.95 ... 10.00	-20 ... 90	45	500
VSL 10-7 PE	PE	-0.95 ... 10.00	-30 ... 70	60	50
VSL 10-7 PU	PU	-0.95 ... 10.00	-40 ... 85	60	50
VSL 12-9 PE	PE	-0.95 ... 10.00	-20 ... 70	70	100
VSL 12-9 PU	PU	-0.95 ... 10.00	-20 ... 90	70	50
VSL 14-11 PU	PU	-0.95 ... 10.00	-20 ... 90	100	100
VSL 15-9 PVC-G	PVC with tissue	-0.95 ... 10.00	-20 ... 70	50	50
VSL 18-12 PVC-DS	PVC with wire spiral	-0.90 ... 5.00	-20 ... 70	85	30
VSL 21-12 PVC-G	PVC with tissue	-0.95 ... 10.00	-20 ... 70	80	50
VSL 26-19 PVC-DS	PVC with wire spiral	-0.90 ... 5.00	-20 ... 70	85	50
VSL 27-20 PU-DS	PU with wire spiral	-0.95 ... 4.00	-20 ... 90	70	10
VSL 33-25 PVC-DS	PVC with wire spiral	-0.85 ... 4.00	-20 ... 70	95	50
VSL 33-25 PU-DS	PU with wire spiral	-0.95 ... 4.00	-40 ... 90	75	10
VSL 41-32 PVC-DS	PVC with wire spiral	-0.85 ... 4.00	-20 ... 70	110	30
VSL 42-32 PU-DS	PU with wire spiral	-0.95 ... 3.20	-20 ... 90	95	10
VSL 41-35 PVC-PS	PVC with PVC-spiral	-0.50 ... 0.50	-20 ... 70	65	50
VSL 44-38 PU-DS	PU with wire spiral	-0.82 ... 3.12	-20 ... 90	95	10
VSL 47-38 PU-DS	PU with wire spiral	-0.94 ... 4.39	-20 ... 90	115	10
VSL 48-38 PVC-DS	PVC with wire spiral	-0.88 ... 7.00	-20 ... 70	120	30
VSL 48-40 PVC-PS	PVC with PVC-spiral	-0.49 ... 1.00	-20 ... 70	70	50
VSL 60-50 PU-DS	PU with wire spiral	-0.78 ... 2.90	-20 ... 90	95	20
VSL 60-50 HV PU-DS	PU with wire spiral	-0.96 ... 3.20	-20 ... 90	145	10
VSL 61-50 PVC-DS	PVC with wire spiral	-0.78 ... 1.50	-20 ... 70	90	10
VSL 71-60 PVC-DS	PVC with wire spiral	-0.73 ... 1.27	-20 ... 70	110	25
VSL 71-60 PU-DS	PU with wire spiral	-0.74 ... 2.55	-20 ... 90	105	10
VSL 71-60 PU-DS	PU with wire spiral	-0.89 ... 3.60	-20 ... 90	170	10
VSL 85-75 PVC-PS	PVC with PVC-spiral	-0.59 ... 1.00	-20 ... 70	130	10
VSL 85-75 PU-DS	PU with wire spiral	-0.59 ... 2.00	-20 ... 90	130	10
VSL 87-75 PU-DS	PU with wire spiral	-0.96 ... 3.20	-20 ... 90	210	10

\*In reference to media and ambient temperature of +20° C

\*\*Referred to the inner side of the hose bend in a static state

\*\*\*Please indicate the tube length when placing the order.

# Vacuum / Compressed Air Hoses VSL

Material PA, PE, PU, PVC

**Design Data Vacuum / Compressed Air Hoses VSL**

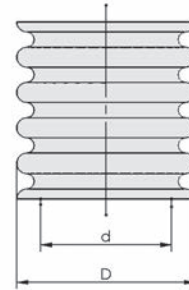
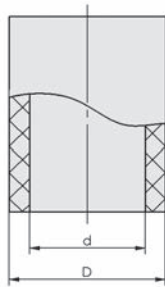

VSL 4/2 - VSL 21/12

VSL 26/19 - VSL 87/75

Type	d [mm]	D [mm]
VSL 4-2 PE	2	4
VSL 4-2 PU	2	4
VSL 4-2.7 PA	3	4
VSL 6-4 PE	4	6
VSL 6-4 PU	4	6
VSL 8-6 PE	6	8
VSL 8-6 PU	6	8
VSL 10-7 PE	7	10
VSL 10-7 PU	7	10
VSL 12-9 PE	9	12
VSL 12-9 PU	9	12
VSL 14-11 PU	11	14
VSL 15-9 PVC-G	9	15
VSL 18-12 PVC-DS	12	18
VSL 21-12 PVC-G	12	21
VSL 26-19 PVC-DS	19	26
VSL 27-20 PU-DS	20	27
VSL 33-25 PVC-DS	25	33
VSL 33-25 PU-DS	25	33
VSL 41-32 PVC-DS	32	41
VSL 42-32 PU-DS	32	42
VSL 41-35 PVC-PS	35	41
VSL 44-38 PU-DS	38	44
VSL 47-38 PU-DS	38	47
VSL 48-38 PVC-DS	38	48
VSL 48-40 PVC-PS	40	48
VSL 60-50 PU-DS	50	60
VSL 60-50 HV PU-DS	50	60
VSL 61-50 PVC-DS	50	61
VSL 71-60 PVC-DS	60	71
VSL 71-60 PU-DS	60	71
VSL 85-75 PVC-PS	75	85
VSL 85-75 PU-DS	75	85
VSL 87-75 PU-DS	75	87



# Hose Clamps SSB / SSD

Clamping range from 10 mm to 90 mm



## Suitability for Industry Specific Applications

### Applications

- Hose clamp SSB for securing smooth hoses
- Hose clamp SSD for securing hoses with wire reinforcement



Hose Clamps SSB / SSD

### Design

- Hose clamp made of galvanized steel
- Robust clamping screw for safe clamping

### Our Highlights...

- Hose clamps with diameters up to 84 mm
- High clamping forces due to robust clamping screw

### Your Benefits...

- Fitting for all vacuum hoses in our product range
- Secure clamping of all vacuum hoses, including those with wire spirals



## Designation Code Hose Clamps SSB / SSD

<b>SSB</b>	–	<b>10-16</b>	–	<b>ST-VZ</b>
<b>1</b>		<b>2</b>		<b>3</b>

#### 1 – Abbreviated designation

Code	Version
SSB	Smooth hoses
SSD	Hoses with wire reinforcement

#### 2 – Clamping range

Code	Clamping range in mm
10-16...85-90	ø 10-16 to 85-90

#### 3 – Material

Code	Material
ST-VZ	Steel, plated
A2	Stainless steel

Hose clamp SSB / SSD is delivered in the desired diameter.

Available accessories: cap

Schmalz – The Company

Vacuum Suction Cups

Special Grippers

Gripping Systems

Clamping Systems

Mounting Elements

Vacuum Generators

Valve Technology

Switches and Monitoring

Filters and Connections

Services

Contact

Glossary

Index of Products



# Hose Clamps SSB / SSD

Clamping range from 10 mm to 90 mm



## Ordering Data Hose Clamps SSB / SSD

Type	Part no.	Accessories	Part no.
SSB 10-16 ST-VZ	10.07.10.00001	Cap (rectangular)	20.12.01.00036
SSB 16-27 ST-VZ	10.07.10.00002	Cap (rectangular)	20.12.01.00036
SSB 20-32 ST-VZ	10.07.10.00003	Cap (rectangular)	20.12.01.00036
SSB 32-50 ST-VZ	10.07.10.00004	Cap (rectangular)	20.12.01.00036
SSB 40-60 ST-VZ	10.07.10.00005	Cap (rectangular)	20.12.01.00036
SSB 60-80 ST-VZ	10.07.10.00006	Cap (rectangular)	20.12.01.00036
SSD 24-27 ST-VZ	10.07.10.00086	-	-
SSD 28-32 ST-VZ	10.07.10.00087	-	-
SSD 35-40 ST-VZ	10.07.10.00018	-	-
SSD 38-43 ST-VZ	10.07.10.00019	-	-
SSD 43-49 ST-VZ	10.07.10.00020	-	-
SSD 54-60 ST-VZ	10.07.10.00036	-	-
SSD 60-68 ST-VZ	10.07.10.00017	-	-
SSD 64-70 A2	10.07.10.00098	-	-
SSD 76.5-84 ST-VZ	10.07.10.00037	-	-
SSD 85-90 ST-VZ	10.07.10.00102	-	-



## Technical Data Hose Clamps SSB / SSD

Type	Clamping range [mm]
SSB 10-16 ST-VZ	10.0 ... 16.0
SSB 16-27 ST-VZ	16.0 ... 27.0
SSB 20-32 ST-VZ	20.0 ... 32.0
SSB 32-50 ST-VZ	32.0 ... 50.0
SSB 40-60 ST-VZ	40.0 ... 60.0
SSB 60-80 ST-VZ	60.0 ... 80.0
SSD 24-27 ST-VZ	24.0 ... 27.0
SSD 28-32 ST-VZ	28.0 ... 32.0
SSD 35-40 ST-VZ	35.0 ... 40.0
SSD 38-43 ST-VZ	38.0 ... 43.0
SSD 43-49 ST-VZ	43.0 ... 49.0
SSD 54-60 ST-VZ	54.0 ... 60.0
SSD 60-68 ST-VZ	60.0 ... 68.0
SSD 64-70 A2	64.0 ... 70.0



# Hose Clamps SSB / SSD

Clamping range from 10 mm to 90 mm



## Design Data Hose Clamps SSB / SSD

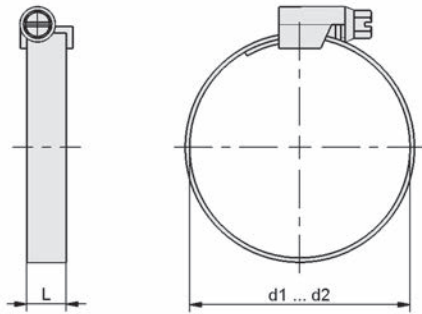

SSB

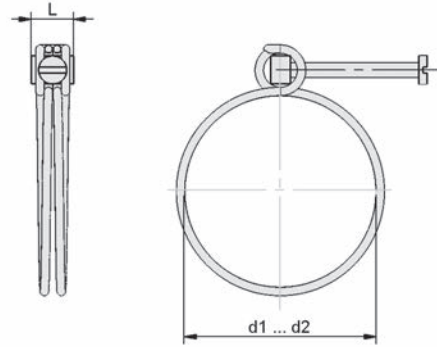

SSD

Type	d1 [mm]	d2 [mm]	L [mm]
SSB 10-16 ST-VZ	10	16	9
SSB 16-27 ST-VZ	16	27	9
SSB 20-32 ST-VZ	20	32	9
SSB 32-50 ST-VZ	32	50	9
SSB 40-60 ST-VZ	40	60	9
SSB 60-80 ST-VZ	60	80	9
SSD 24-27 ST-VZ	24	27	12
SSD 28-32 ST-VZ	28	32	12
SSD 35-40 ST-VZ	35	40	13
SSD 38-43 ST-VZ	38	43	13
SSD 43-49 ST-VZ	43	49	15
SSD 54-60 ST-VZ	54	60	15
SSD 60-68 ST-VZ	60	68	15
SSD 64-70 A2	64	70	13
SSD 76.5-84 ST-VZ	77	84	18
SSD 85-90 ST-VZ	85	90	19

Schmalz – The Company  
 Vacuum Suction Cups  
 Special Grippers  
 Gripping Systems  
 Clamping Systems  
 Mounting Elements  
 Vacuum Generators  
 Valve Technology  
 Switches and Monitoring  
 Filters and Connections  
 Services  
 Contact  
 Glossary  
 Index of Products



# Screw in Push Fittings

Hose outer diameter from 4 mm to 14 mm



## Suitability for Industry Specific Applications

### Applications

- Screw in push fittings for quick connection of smooth hoses without the need for tools
- For use as a connecting element in vacuum systems
- Suitable for hoses with external tolerances in accordance with CETOP RP 54 P



Screw in Push Fittings

### Design

- Screw in push fitting, clamping clip and unlocking element made of nickel-plated brass
- Hose connection sealed with an NBR gasket
- Whitworth pipe thread

### Our Highlights...

- Screw in push fittings with integrated clamping clip
- Hoses clamped on the outside
- Absolutely vacuum tight, shaped for optimum flow
- Body and clamping clip made of nickel plated brass

### Your Benefits...

- Quick and safe connection and disconnection of all smooth hoses without the need for tools
- No pinching of the hose: full cross section remains open
- Specially designed for vacuum applications
- Suitable for very rough use; long lifetime; re-usable



## Ordering Data Screw in Push Fittings

Type	Part no.
Plug union, straight	STV-GE M5-AG 4
Plug union, straight	STV-GE M5-AG 6
Plug union, straight	STV-GE G1/8-AG 4
Plug union, straight	STV-GE G1/8-AG 6
Plug union, straight	STV-GE G1/8-AG 8
Plug union, straight	STV-GE G1/4-AG 4
Plug union, straight	STV-GE G1/4-AG 6
Plug union, straight	STV-GE G1/4-AG 8
Plug union, straight	STV-GE G1/4-AG 10
Plug union, straight	STV-GE G1/4-AG 12
Plug union, straight	STV-GE G3/8-AG 8
Plug union, straight	STV-GE G3/8-AG 10
Plug union, straight	STV-GE G3/8-AG 12
Plug union, straight	STV-GE G3/8-AG 14
Plug union, straight	STV-GE G1/2-AG 10
Plug union, straight	STV-GE G1/2-AG 12
Plug union, straight	STV-GE G1/2-AG 14
Plug union, straight	STVI-GE G1/8-IG 4





# Screw in Push Fittings

Hose outer diameter from 4 mm to 14 mm



## Ordering Data Screw in Push Fittings

Type		Part no.
Plug union, straight	STVI-GE G1/8-IG 6	10.08.02.00150
Plug union, straight	STVI-GE G1/8-IG 8	10.08.02.00151
Plug union, straight	STVI-GE G1/4-IG 4	10.08.02.00152
Plug union, straight	STVI-GE G1/4-IG 6	10.08.02.00153
Plug union, straight	STVI-GE G1/4-IG 8	10.08.02.00154
Plug union, straight	STVI-GE G1/4-IG 10	10.08.02.00260

Type		Part no.
Plug union, elbow	STV-W M5-AG 4	10.08.02.00155
Plug union, elbow	STV-W M5-AG 6	10.08.02.00235
Plug union, elbow	STV-W M5-AG 6	10.08.02.00296
Plug union, elbow	STV-W G1/8-AG 4	10.08.02.00156
Plug union, elbow	STV-W G1/8-AG 6	10.08.02.00288
Plug union, elbow	STV-W G1/8-AG 6	10.08.02.00158
Plug union, elbow	STV-W G1/8-AG 8	10.08.02.00160
Plug union, elbow	STV-W G1/4-AG 4	10.08.02.00157
Plug union, elbow	STV-W G1/4-AG 6	10.08.02.00159
Plug union, elbow	STV-W G1/4-AG 8	10.08.02.00161
Plug union, elbow	STV-W G1/4-AG 10	10.08.02.00254
Plug union, elbow	STV-W G1/4-AG 12	10.08.02.00162
Plug union, elbow	STV-W G3/8-AG 8	10.08.02.00236
Plug union, elbow	STV-W G3/8-AG 10	10.08.02.00255
Plug union, elbow	STV-W G3/8-AG 12	10.08.02.00163
Plug union, elbow	STV-W G1/2-AG 10	10.08.02.00256
Plug union, elbow	STV-W G1/2-AG 12	10.08.02.00164
Plug union, elbow	STV-WF M5-AG 4	10.08.02.00165
Plug union, elbow	STV-WF G1/8-AG 4	10.08.02.00166
Plug union, elbow	STV-WF G1/8-AG 6	10.08.02.00168
Plug union, elbow	STV-WF G1/8-AG 8	10.08.02.00170
Plug union, elbow	STV-WF G1/8-AG 10	10.08.02.00257
Plug union, elbow	STV-WF G1/4-AG 4	10.08.02.00167
Plug union, elbow	STV-WF G1/4-AG 6	10.08.02.00169
Plug union, elbow	STV-WF G1/4-AG 8	10.08.02.00171
Plug union, elbow	STV-WF G1/4-AG 10	10.08.02.00258
Plug union, elbow	STV-WF G3/8-AG 8	10.08.02.00234
Plug union, elbow	STV-WF G3/8-AG 10	10.08.02.00259

Type		Part no.
Plug union, T	STV-T M5-AG 4	10.09.02.00038
Plug union, T	STV-T G1/8-AG 4	10.09.02.00039
Plug union, T	STV-T G1/8-AG 6	10.09.02.00040
Plug union, T	STV-T G1/8-AG 8	10.09.02.00041
Plug union, T	STV-T G1/4-AG 6	10.09.02.00042
Plug union, T	STV-T G1/4-AG 8	10.09.02.00043
Plug union, T	STV-T G1/4-AG 10	10.09.02.00044
Plug union, T	STV-T G1/4-AG 12	10.09.02.00045
Plug connector, T	SVB-T 4	10.09.02.00020
Plug connector, T	SVB-T 6	10.09.02.00021
Plug connector, T	SVB-T 8	10.09.02.00022
Plug connector, T	SVB-T 10	10.09.02.00025
Plug connector, T	SVB-T 12	10.09.02.00023
Plug connector, T	SVB-T 14	10.09.02.00046

Schmalz –  
The CompanyVacuum  
Suction CupsSpecial  
GrippersGripping  
SystemsClamping  
SystemsMounting  
ElementsVacuum  
GeneratorsValve  
TechnologySwitches and  
MonitoringFilters and  
Connections

Services

Contact

Glossary

Index of  
Products

# Screw in Push Fittings

Hose outer diameter from 4 mm to 14 mm

Schmalz - The Company  
Vacuum Suction Cups  
Special Grippers  
Gripping Systems  
Clamping Systems  
Mounting Elements  
Vacuum Generators  
Valve Technology  
Switches and Monitoring  
Filters and Connections  
Services  
Contact  
Glossary  
Index of Products

## Ordering Data Screw in Push Fittings

Type		Part no.
Sealing plug	VRS-STECH 4x14.9	10.08.06.00011
Sealing plug	VRS-STECH 6x14.4	10.08.06.00012
Sealing plug	VRS-STECH 8x16.4	10.08.06.00013
Sealing plug	VRS-STECH 10x18	10.08.06.00060
Sealing plug	VRS-STECH 12x16.5	10.08.06.00041

## Technical Data Screw in Push Fittings

Pressure range (operating pressure) [bar]	Operating temperature [°C]
-0.95 ... 24.00	-50 ... 200

## Design Data Screw in Push Fittings

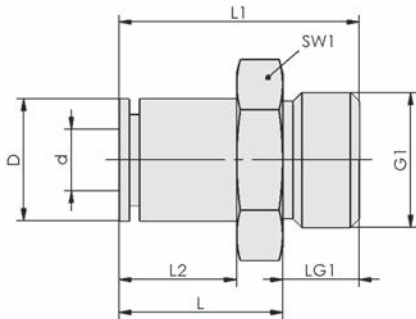

STV-GE

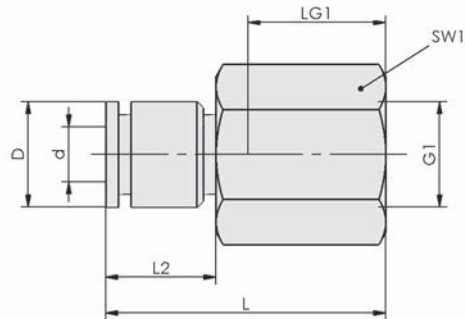

STVI-GE

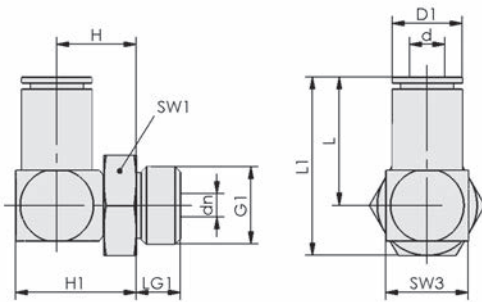

STV-W

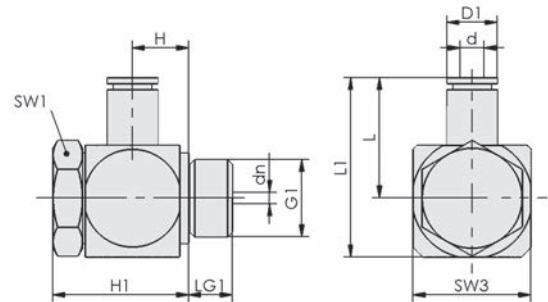

STV-WF

# Screw in Push Fittings

Hose outer diameter from 4 mm to 14 mm



## Design Data Screw in Push Fittings

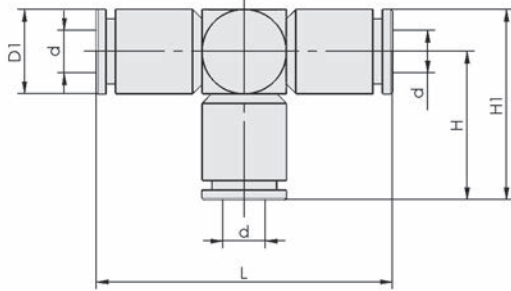

SVB-T

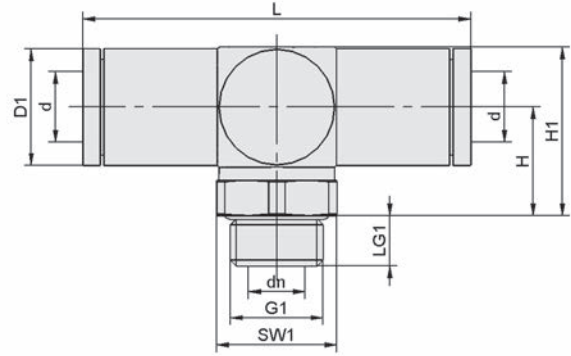

STV-T

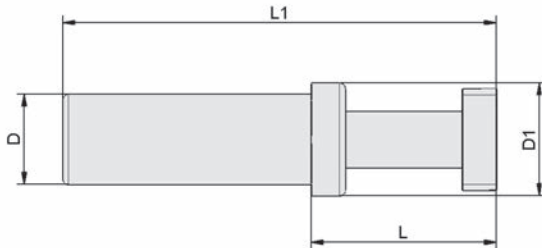

VRS-STEC

Type	d [mm]	D [mm]	G1	L [mm]	L1 [mm]	L2 [mm]	LG1 [mm]	SW1 [mm]
STV-GE M5-AG 4	4	7.9	M5-M	15.0	19.5	11.4	5	8
STV-GE M5-AG 6	6	9.9	M5-M	18.8	23.3	14.3	5	10
STV-GE G1/8-AG 4	4	7.9	G1/8"-M	13.7	19.2	9.5	6	13
STV-GE G1/8-AG 6	6	11.4	G1/8"-M	16.4	21.9	12.1	6	13
STV-GE G1/8-AG 8	8	14.0	G1/8"-M	20.7	26.2	16.4	6	14
STV-GE G1/4-AG 4	4	8.6	G1/4"-M	11.8	19.6	7.3	8	17
STV-GE G1/4-AG 6	6	11.2	G1/4"-M	15.2	23.0	10.7	8	17
STV-GE G1/4-AG 8	8	13.9	G1/4"-M	17.8	25.2	12.8	8	17
STV-GE G1/4-AG 10	10	16.5	G1/4"-M	23.4	30.8	18.4	8	17
STV-GE G1/4-AG 12	12	19.5	G1/4"-M	29.0	36.0	21.1	7	20
STV-GE G3/8-AG 8	8	14.6	G3/8"-M	17.4	25.0	11.8	8	20
STV-GE G3/8-AG 10	10	16.5	G3/8"-M	20.1	27.6	14.6	8	20
STV-GE G3/8-AG 12	12	19.5	G3/8"-M	23.6	31.0	17.6	8	20
STV-GE G3/8-AG 14	14	21.5	G3/8"-M	30.5	37.8	22.1	8	22



Schmalz – The Company  
 Vacuum Suction Cups  
 Special Grippers  
 Gripping Systems  
 Clamping Systems  
 Mounting Elements  
 Vacuum Generators  
 Valve Technology  
 Switches and Monitoring  
 Filters and Connections  
 Services  
 Contact  
 Glossary  
 Index of Products

# Screw in Push Fittings

Hose outer diameter from 4 mm to 14 mm



## Design Data Screw in Push Fittings

Type	d [mm]	D [mm]	G1	L [mm]	L1 [mm]	L2 [mm]	LG1 [mm]	SW1 [mm]
STV-GE G1/2-AG 10	10	16.5	G1/2"-M	18.5	28.0	12.5	10	24
STV-GE G1/2-AG 12	12	19.5	G1/2"-M	24.0	33.5	18.0	10	24
STV-GE G1/2-AG 14	14	21.5	G1/2"-M	25.0	34.5	19.0	10	24
STVI-GE G1/8-IG 4	4	8.5	G1/8"-F	23.5	-	9.5	8	14
STVI-GE G1/8-IG 6	6	11.5	G1/8"-F	26.5	-	12.0	8	14
STVI-GE G1/8-IG 8	8	14.5	G1/8"-F	29.5	-	15.0	8	14
STVI-GE G1/4-IG 4	4	8.5	G1/4"-F	30.5	-	9.5	12	17
STVI-GE G1/4-IG 6	6	11.5	G1/4"-F	30.5	-	12.0	12	17
STVI-GE G1/4-IG 8	8	14.5	G1/4"-F	33.5	-	15.0	12	17
STVI-GE G1/4-IG 10	10	16.5	G1/4"-F	37.0	-	17.5	12	17

Type	d [mm]	dn [mm]	D1 [mm]	G1	H [mm]	H1 [mm]	L [mm]	L1 [mm]	LG1 [mm]	SW1 [mm]	SW3 [mm]
STV-W M5-AG 4	4	2.5	8.5	M5-M	8.7	13.6	16.4	21.4	4.7	8	10
STV-W M5-AG 6	6	2.5	9.9	M5-M	8.7	13.6	19.7	24.7	4.7	8	10
STV-W M5-AG 6	6	4.0	11.5	M5-M	13.0	16.5	20.8	25.5	4.0	8	8
STV-W G1/8-AG 4	4	3.0	8.5	G1/8"-M	10.7	15.7	16.4	27.1	5.7	13	10
STV-W G1/8-AG 6	6	4.0	11.5	G1/8"-M	12.5	16.5	20.8	27.5	6.0	13	8
STV-W G1/8-AG 6	6	4.1	11.3	G1/8"-M	12.8	19.9	20.1	27.1	5.7	13	14
STV-W G1/8-AG 8	8	5.5	14.6	G1/8"-M	13.7	21.8	24.0	32.0	5.7	13	16
STV-W G1/4-AG 4	4	3.0	8.5	G1/4"-M	11.5	16.8	16.4	25.5	7.5	17	10
STV-W G1/4-AG 6	6	4.1	11.3	G1/4"-M	13.5	20.4	20.2	29.4	7.5	17	14
STV-W G1/4-AG 8	8	6.5	14.6	G1/4"-M	14.8	22.7	24.0	33.2	7.5	17	16
STV-W G1/4-AG 10	10	8.0	16.6	G1/4"-M	15.5	24.5	27.2	36.3	7.5	17	18
STV-W G1/4-AG 12	12	8.5	19.8	G1/4"-M	17.0	27.0	34.5	44.5	7.5	17	20
STV-W G3/8-AG 8	8	6.5	14.3	G3/8"-M	16.0	23.9	23.7	34.6	7.5	20	16
STV-W G3/8-AG 10	10	8.0	16.5	G3/8"-M	17.0	26.0	35.1	46.0	7.5	20	18
STV-W G3/8-AG 12	12	9.0	19.8	G3/8"-M	18.0	27.9	34.1	45.0	7.5	20	20
STV-W G1/2-AG 10	10	8.0	16.6	G1/2"-M	17.6	26.5	27.0	40.0	9.5	24	18
STV-W G1/2-AG 12	12	9.0	19.8	G1/2"-M	18.5	28.5	34.3	47.3	9.5	24	20
STV-WF M5-AG 4	4	2.5	8.6	M5-M	8.4	16.6	16.5	20.1	3.5	8	9
STV-WF G1/8-AG 4	4	5.4	8.6	G1/8"-M	9.8	23.6	17.4	25.3	5.0	14	16
STV-WF G1/8-AG 6	6	5.4	11.4	G1/8"-M	9.8	23.6	21.4	25.3	5.0	14	16
STV-WF G1/8-AG 8	8	5.4	14.3	G1/8"-M	9.8	23.6	23.4	31.3	5.0	14	16
STV-WF G1/8-AG 10	10	10.0	16.7	G1/8"-M	9.8	23.6	25.2	33.6	5.0	14	17
STV-WF G1/4-AG 4	4	7.2	8.5	G1/4"-M	9.8	23.9	19.5	29.4	6.7	17	20
STV-WF G1/4-AG 6	6	7.2	11.8	G1/4"-M	9.8	23.9	22.9	32.9	6.7	17	20
STV-WF G1/4-AG 8	8	7.2	14.5	G1/4"-M	9.8	23.9	25.6	35.5	6.7	17	20
STV-WF G1/4-AG 10	10	7.2	16.6	G1/4"-M	10.0	23.9	27.8	37.7	6.7	17	20
STV-WF G3/8-AG 8	8	9.4	14.3	G3/8"-M	10.0	24.9	26.7	37.6	6.7	22	22
STV-WF G3/8-AG 10	10	9.4	16.7	G3/8"-M	10.0	24.9	29.2	40.1	6.7	22	22



- Schmalz – The Company
- Vacuum Suction Cups
- Special Grippers
- Gripping Systems
- Clamping Systems
- Mounting Elements
- Vacuum Generators
- Valve Technology
- Switches and Monitoring
- Filters and Connections
- Services
- Contact
- Glossary
- Index of Products

# Screw in Push Fittings

Hose outer diameter from 4 mm to 14 mm



## Design Data Screw in Push Fittings

Type	d [mm]	dn [mm]	D1 [mm]	G1	H [mm]	H1 [mm]	L [mm]	LG1 [mm]	SW1 [mm]
STV-T M5-AG 4	4	2.0	8.7	M5-M	10	14.0	34.0	4.5	8
STV-T G1/8-AG 4	4	3.0	8.7	G1/8"-M	12	16.0	32.5	5.5	13
STV-T G1/8-AG 6	6	4.0	12.0	G1/8"-M	14	20.0	41.5	5.5	13
STV-T G1/8-AG 8	8	5.5	14.1	G1/8"-M	15	22.0	48.7	5.5	13
STV-T G1/4-AG 6	6	4.0	11.3	G1/4"-M	13	18.4	41.0	7.6	17
STV-T G1/4-AG 8	8	6.5	14.1	G1/4"-M	17	23.2	48.5	7.6	17
STV-T G1/4-AG 10	10	8.0	16.5	G1/4"-M	15	23.2	54.9	7.6	17
STV-T G1/4-AG 12	12	8.4	19.6	G1/4"-M	17	26.6	69.0	7.6	17
SVB-T 4	4	-	8.6	-	17	20.6	34.0	-	-
SVB-T 6	6	-	11.9	-	21	27.0	42.0	-	-
SVB-T 8	8	-	14.4	-	25	31.9	49.0	-	-
SVB-T 10	10	-	16.7	-	28	36.0	55.5	-	-
SVB-T 12	12	-	19.9	-	34	44.0	69.0	-	-
SVB-T 14	14	-	21.3	-	36	46.5	72.0	-	-

Type	D [mm]	D1 [mm]	L [mm]	L1 [mm]
VRS-STECC 4x14.9	4	6	15	35
VRS-STECC 6x14.4	6	8	15	35
VRS-STECC 8x16.4	8	10	17	39
VRS-STECC 10x18	10	10	18	42
VRS-STECC 12x16.5	12	14	17	44

Schmalz –  
The CompanyVacuum  
Suction CupsSpecial  
GrippersGripping  
SystemsClamping  
SystemsMounting  
ElementsVacuum  
GeneratorsValve  
TechnologySwitches and  
MonitoringFilters and  
Connections

Services

Contact

Glossary

Index of  
Products

# Accessories for Screw Unions

Connection thread M5 to G1-1/2"



## Suitability for Industry Specific Applications

### Applications

- Accessories for screw-in unions to seal threaded holes, to convert to a smaller or larger thread or to extend the unions



Accessories for Screw Unions

### Design

- Accessories made of robust brass with nickel-plated surfaces

### Our Highlights...

- Wide range of accessories
- All accessories made of brass with nickel-plated surfaces

### Your Benefits...

- All accessories from a single source
- Long lifetime, reusable, mechanically strong and with a good looking finish



## Ordering Data Accessories for Screw Unions

Type		Part no.
Sealing screw with collar	VRS-SB M5-AG ISKT O-Ring	10.08.06.00064
Sealing screw with collar	VRS-SB G1/8-AG ISKT O-Ring	10.08.06.00043
Sealing screw with collar	VRS-SB G1/4-AG ISKT O-Ring	10.08.06.00044
Sealing screw with collar	VRS-SB G3/8-AG ISKT O-Ring	10.08.06.00045
Sealing screw with collar	VRS-SB G1/2-AG ISKT O-Ring	10.08.06.00046
Sealing screw without collar	VRS-S G1/8-AG	10.08.06.00047
Sealing screw without collar	VRS-S G1/4-AG	10.08.06.00048
Sealing screw without collar	VRS-S G3/8-AG	10.08.06.00049
Sealing screw without collar	VRS-S G1/2-AG	10.08.06.00050
Sealing screw without collar	VRS-S G3/4-AG	10.08.06.00051

Type		Part no.
Bushing with hexagon	MUF-S M5-IG 9 SW8 MS-V	10.08.05.00124
Bushing with hexagon	MUF-S G1/8-IG 18 SW14 MS-V	10.08.05.00125
Bushing with hexagon	MUF-S G1/4-IG 26 SW17 MS-V	10.08.05.00126
Bushing with hexagon	MUF-S G3/8-IG 26 SW22 MS-V	10.08.05.00127
Bushing with hexagon	MUF-S G1/2-IG 30 SW27 MS-V	10.08.05.00128
Bushing with hexagon	MUF-S G3/4-IG 28 SW32 MS-V	10.08.05.00129
Bushing with hexagon	MUF-S G1-IG 33 SW41 MS-V	10.08.05.00130
Extension with hexagon	VRL-S M5x8 MS-V	10.08.04.00088
Extension with hexagon	VRL-S G1/8x15 MS-V	10.08.04.00090
Extension with hexagon	VRL-S G1/4x18 MS-V	10.08.04.00092
Extension with hexagon	VRL-S G1/2x22 MS-V	10.08.04.00097



# Accessories for Screw Unions

Connection thread M5 to G1-1/2"



## Ordering Data Accessories for Screw Unions

Type		Part no.	
Reduction piece with hexagon	RED-STK G1/8-AG M5-IG MS-V	10.08.04.00089	Vacuum Suction Cups
Reduction piece with hexagon	RED-STK G1/4-AG G1/8-IG MS-V	10.08.04.00091	
Reduction piece with hexagon	RED-STK G3/8-AG G1/8-IG MS-V	10.08.04.00093	
Reduction piece with hexagon	RED-STK G3/8-AG G1/4-IG MS-V	10.08.04.00094	Special Grippers
Reduction piece with hexagon	RED-STK G1/2-AG G1/4-IG MS-V	10.08.04.00095	
Reduction piece with hexagon	RED-STK G1/2-AG G3/8-IG MS-V	10.08.04.00096	
Reduction piece with hexagon	RED-STK G3/4-AG G3/8-IG MS-V	10.08.04.00098	Gripping Systems
Reduction piece with hexagon	RED-STK G3/4-AG G1/2-IG MS-V	10.08.04.00099	
Reduction piece with hexagon	RED-STK G1-AG G1/2-IG MS-V	10.08.04.00100	
Reduction piece with hexagon	RED-STK G1-AG G3/4-IG MS-V	10.08.04.00101	Clamping Systems
Double nipple with hexagon	DOP-NIP-S M5-AGx4	10.08.05.00131	
Double nipple with hexagon	DOP-NIP-S G1/8-AGx5	10.08.05.00132	
Double nipple with hexagon	DOP-NIP-S G1/4-AGx5	10.08.05.00133	Mounting Elements
Double nipple with hexagon	DOP-NIP-S G3/8-AGx5	10.08.05.00134	
Double nipple with hexagon	DOP-NIP-S G1/2-AGx6	10.08.05.00135	
Double nipple with hexagon	DOP-NIP-S G3/4-AGx8	10.08.05.00136	Vacuum Generators
Double nipple with hexagon	DOP-NIP-S G1-AGx10	10.08.05.00137	
Reduction nipple with hexagon	RED-NIP-S G1/8-AG M5-AG MS V	10.08.05.00138	
Reduction nipple with hexagon	RED-NIP-S G1/4-AG G1/8-AG MS V	10.08.05.00139	Valve Technology
Reduction nipple with hexagon	RED-NIP-S G3/8-AG G1/4-AG MS V	10.08.05.00141	
Reduction nipple with hexagon	RED-NIP-S G1/2-AG G1/4-AG MS V	10.08.05.00140	
Reduction nipple with hexagon	RED-NIP-S G1/2-AG G3/8-AG MS V	10.08.05.00142	Switches and Monitoring
Reduction nipple with hexagon	RED-NIP-S G3/4-AG G1/2-AG MS V	10.08.05.00143	
Reduction nipple with hexagon	RED-NIP-S G1-AG G1/2-AG MS V	10.08.05.00144	
Reduction nipple with hexagon	RED-NIP-S G1-AG G3/4-AG MS V	10.08.05.00145	Filters and Connections

Type		Part no.	
Hose sleeve	ST M3-AG 2 MS-V	10.08.03.00151	Services
Hose sleeve	ST M5-AG 4 MS-V	10.08.03.00152	
Hose sleeve	ST G1/8-AG 4 MS-V	10.08.03.00153	
Hose sleeve	ST G1/8-AG 6 MS-V	10.08.03.00154	Contact
Hose sleeve	ST G1/8-AG 9 MS-V	10.08.03.00155	
Hose sleeve	ST G1/4-AG 6 MS-V	10.08.03.00156	
Hose sleeve	ST G1/4-AG 9 MS-V	10.08.03.00157	Glossary
Hose sleeve	ST G1/4-AG 12 MS-V	10.08.03.00158	
Hose sleeve	ST G3/8-AG 9 MS-V	10.08.03.00159	
Hose sleeve	ST G3/8-AG 12 MS-V	10.08.03.00160	Index of Products
Hose sleeve	ST G1/2-AG 9 MS-V	10.08.03.00161	
Hose sleeve	ST G1/2-AG 12 MS-V	10.08.03.00162	
Hose sleeve	ST G1/2-AG 19 MS-V	10.08.03.00163	
Hose sleeve	ST G3/4-AG 12 MS-V	10.08.03.00164	
Hose sleeve	ST G3/4-AG 19 MS-V	10.08.03.00165	
Hose sleeve	ST G3/4-AG 25 MS-V	10.08.03.00166	
Hose sleeve	ST G1-AG 25 MS-V	10.08.03.00167	
Hose sleeve	ST G1-AG 32 MS-V	10.08.03.00168	
Hose sleeve	ST G1-1/4-AG 32 MS-V	10.08.03.00169	
Hose sleeve	ST G1-1/4-AG 38 MS-V	10.08.03.00123	
Hose sleeve	ST G1-1/2-AG 38 MS-V	10.08.03.00170	



# Accessories for Screw Unions

Connection thread M5 to G1-1/2"

Schmalz – The Company  
Vacuum Suction Cups



## Technical Data Accessories for Screw Unions

Pressure range (operating pressure) [bar]	Operating temperature [°C]
-0.95 ... 16.00	-20 ... 60

Special Grippers



## Design Data Accessories for Screw Unions

Gripping Systems  
Clamping Systems  
Mounting Elements

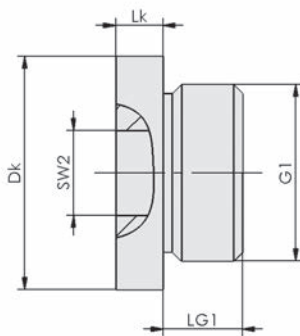

VRS-SB

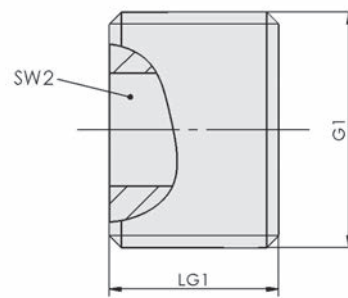

VRS-S

Valve Technology  
Switches and Monitoring  
Filters and Connections

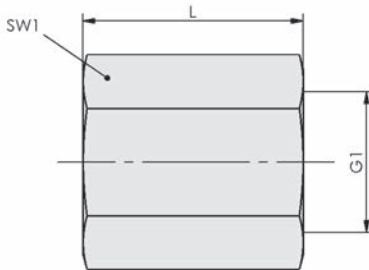

MUF-S

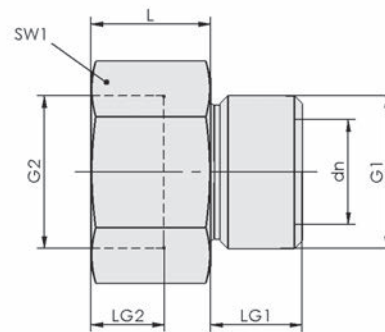

VRL-S

Services  
Contact  
Glossary  
Index of Products

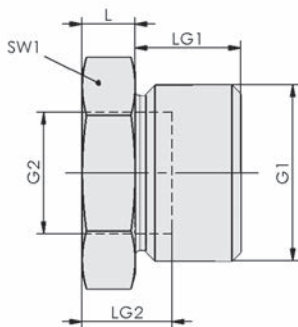

RED-STK

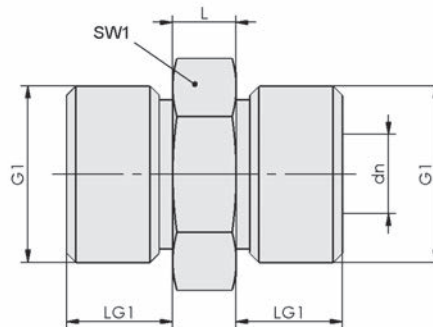

DOP-NIP



# Accessories for Screw Unions

Connection thread M5 to G1-1/2"



## Design Data Accessories for Screw Unions

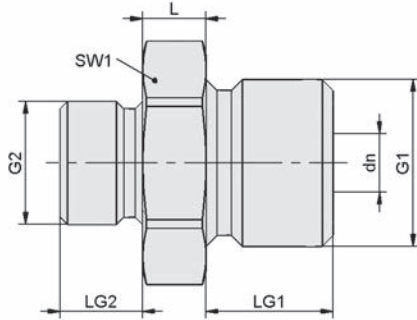

RED-NIP

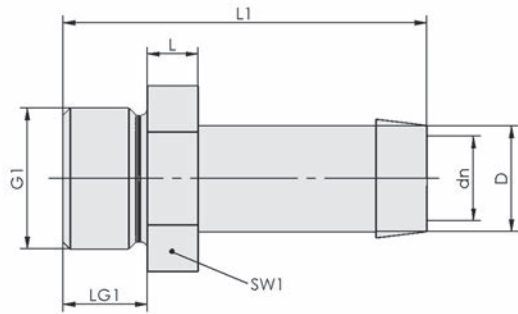

ST

Type	Dk [mm]	G1	LG1 [mm]	Lk [mm]	SW2 [mm]
VRS-SB M5-AG ISKT O-Ring	8	M5-M	5.0	2.5	3
VRS-SB G1/8-AG ISKT O-Ring	14	G1/8"-M	5.5	3.5	5
VRS-SB G1/4-AG ISKT O-Ring	18	G1/4"-M	7.5	4.5	6
VRS-SB G3/8-AG ISKT O-Ring	22	G3/8"-M	7.5	4.5	8
VRS-SB G1/2-AG ISKT O-Ring	27	G1/2"-M	9.5	5.0	10
VRS-S G1/8-AG	-	G1/8"-M	6.0	-	5
VRS-S G1/4-AG	-	G1/4"-M	9.0	-	6
VRS-S G3/8-AG	-	G3/8"-M	10.0	-	8
VRS-S G1/2-AG	-	G1/2"-M	12.0	-	10
VRS-S G3/4-AG	-	G3/4"-M	10.0	-	12

Type	dn [mm]	G1	G2	L [mm]	LG1 [mm]	LG2 [mm]	SW1 [mm]
MUF-S M5-IG 9 SW8 MS-V	-	M5-F	-	9	-	-	8
MUF-S G1/8-IG 18 SW14 MS-V	-	G1/8"-F	-	18	-	-	14
MUF-S G1/4-IG 26 SW17 MS-V	-	G1/4"-F	-	26	-	-	17
MUF-S G3/8-IG 26 SW22 MS-V	-	G3/8"-F	-	26	-	-	22
MUF-S G1/2-IG 30 SW27 MS-V	-	G1/2"-F	-	30	-	-	27
MUF-S G3/4-IG 28 SW32 MS-V	-	G3/4"-F	-	28	-	-	32
MUF-S G1-IG 33 SW41 MS-V	-	G1"-F	-	33	-	-	41
VRL-S M5x8 MS-V	2.5	M5-M	M5-F	8	4.5	6.6	8
VRL-S G1/8x15 MS-V	5.0	G1/8"-M	G1/8"-F	15	8.0	13.0	14
VRL-S G1/4x18 MS-V	7.0	G1/4"-M	G1/4"-F	18	10.0	15.0	17
VRL-S G1/2x22 MS-V	12.0	G1/2"-M	G1/2"-F	22	12.0	16.3	24

# Accessories for Screw Unions

Connection thread M5 to G1-1/2"



## Design Data Accessories for Screw Unions

Type	dn [mm]	G1	G2	L [mm]	LG1 [mm]	LG2 [mm]	SW1 [mm]
RED-STK G1/8-AG M5-IG MS-V	-	G1/8"-M	M5-F	4	6.5	10.0	14
RED-STK G1/4-AG G1/8-IG MS-V	-	G1/4"-M	G1/8"-F	4	10.0	14.0	17
RED-STK G3/8-AG G1/8-IG MS-V	-	G3/8"-M	G1/8"-F	5	10.0	15.0	19
RED-STK G3/8-AG G1/4-IG MS-V	-	G3/8"-M	G1/4"-F	5	10.0	15.0	19
RED-STK G1/2-AG G1/4-IG MS-V	-	G1/2"-M	G1/4"-F	6	12.0	18.0	24
RED-STK G1/2-AG G3/8-IG MS-V	-	G1/2"-M	G3/8"-F	6	12.0	18.0	24
RED-STK G3/4-AG G3/8-IG MS-V	-	G3/4"-M	G3/8"-F	7	14.0	21.0	32
RED-STK G3/4-AG G1/2-IG MS-V	-	G3/4"-M	G1/2"-F	7	14.0	21.0	32
RED-STK G1-AG G1/2-IG MS-V	-	G1"-M	G1/2"-F	8	16.0	24.0	41
RED-STK G1-AG G3/4-IG MS-V	-	G1"-M	G3/4"-F	8	16.1	24.1	41
DOP-NIP-S M5-AGx4	2.5	M5-M	-	4	4.5	-	8
DOP-NIP-S G1/8-AGx5	4.6	G1/8"-M	-	5	6.5	-	14
DOP-NIP-S G1/4-AGx5	7.6	G1/4"-M	-	5	10.0	-	17
DOP-NIP-S G3/8-AGx5	11.0	G3/8"-M	-	5	9.0	-	19
DOP-NIP-S G1/2-AGx6	12.0	G1/2"-M	-	6	12.0	-	24
DOP-NIP-S G3/4-AGx8	15.0	G3/4"-M	-	8	14.0	-	32
DOP-NIP-S G1-AGx10	20.0	G1"-M	-	10	16.0	-	41
RED-NIP-S G1/8-AG M5-AG MS V	2.5	G1/8"-M	M5-M	4	6.5	4.5	14
RED-NIP-S G1/4-AG G1/8-AG MS V	4.6	G1/4"-M	G1/8"-M	5	10.0	6.5	17
RED-NIP-S G1/2-AG G1/4-AG MS V	7.5	G1/2"-M	G1/4"-M	6	12.0	10.0	24
RED-NIP-S G1/2-AG G3/8-AG MS V	10.0	G1/2"-M	G3/8"-M	6	12.0	10.0	24
RED-NIP-S G3/4-AG G1/2-AG MS V	12.0	G3/4"-M	G1/2"-M	8	14.0	12.0	32
RED-NIP-S G1-AG G1/2-AG MS V	12.0	G1"-M	G1/2"-M	10	16.0	12.0	41
RED-NIP-S G1-AG G3/4-AG MS V	17.0	G1"-M	G3/4"-M	10	16.0	14.0	41

Type	dn [mm]	D [mm]	G1	L [mm]	L1 [mm]	LG1 [mm]	SW1 [mm]	Hose diameter (recom.) d [mm]
ST M3-AG 2 MS-V	1.2	2.4	M3-M	2.0	10.8	3.5	5	2
ST M5-AG 4 MS-V	2.2	4.4	M5-M	3.3	18.4	4.4	8	4
ST G1/8-AG 4 MS-V	3.5	4.5	G1/8"-M	5.0	34.0	8.0	14	4
ST G1/8-AG 6 MS-V	4.4	5.4	G1/8"-M	5.0	34.0	8.0	14	6
ST G1/8-AG 9 MS-V	4.0	8.3	G1/8"-M	5.0	34.0	8.0	14	9
ST G1/4-AG 6 MS-V	4.5	5.5	G1/4"-M	5.0	42.0	10.0	17	6
ST G1/4-AG 9 MS-V	7.5	8.5	G1/4"-M	5.0	42.0	10.0	17	9
ST G1/4-AG 12 MS-V	7.5	13.0	G1/4"-M	5.5	42.0	10.0	17	12
ST G3/8-AG 9 MS-V	7.4	8.5	G3/8"-M	6.0	43.0	10.0	19	9
ST G3/8-AG 12 MS-V	10.0	13.0	G3/8"-M	5.9	43.0	10.0	19	12
ST G1/2-AG 9 MS-V	7.5	8.6	G1/2"-M	6.1	45.0	11.9	24	9
ST G1/2-AG 12 MS-V	11.0	12.0	G1/2"-M	6.0	45.0	12.0	24	12
ST G1/2-AG 19 MS-V	14.3	19.0	G1/2"-M	10.0	58.0	12.0	24	19
ST G3/4-AG 12 MS-V	10.4	13.0	G3/4"-M	8.0	60.0	16.0	32	12
ST G3/4-AG 19 MS-V	16.0	19.0	G3/4"-M	7.8	60.0	15.8	32	19
ST G3/4-AG 25 MS-V	18.5	25.0	G3/4"-M	8.5	60.0	16.0	32	25
ST G1-AG 25 MS-V	22.0	25.0	G1"-M	10.1	62.0	15.8	36	25
ST G1-AG 32 MS-V	26.0	32.0	G1"-M	10.5	62.0	16.0	36	32
ST G1-1/4-AG 32 MS-V	27.9	32.0	G1-1/4"-M	10.3	62.0	15.9	46	32
ST G1-1/4-AG 38 MS-V	32.8	38.2	G1-1/4"-M	8.0	60.0	12.0	48	38
ST G1-1/2-AG 38 MS-V	29.9	38.0	G1-1/2"-M	12.2	64.0	15.5	50	38



Schmalz - The Company  
Vacuum Suction Cups  
Special Grippers  
Gripping Systems  
Clamping Systems  
Mounting Elements  
Vacuum Generators  
Valve Technology  
Switches and Monitoring  
Filters and Connections  
Services  
Contact  
Glossary  
Index of Products

# Sealing Rings DR

For thread from M3 to G1-1/2"



## Suitability for Industry Specific Applications

### Applications

- Sealing of connection nipples and other connecting elements

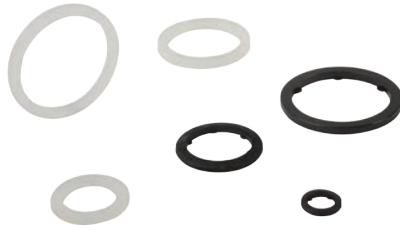

Sealing Rings DR

### Design

- Polyamide sealing ring Easy-Fix with internal locking element to secure the ring on the thread

### Our Highlights...

- Sealing rings made of polyamide PA
- Optionally available with integrated fixing facility (Easy-Fix)
- Wide range of diameters

### Your Benefits...

- Excellent sealing properties
- Sealing ring cannot be lost when mounting and removing the connecting element
- The ideal solution for complete hose connection systems



## Designation Code Sealing Rings DR



#### 1 – Abbreviated designation

Code	Version
DR	DR

#### 2 – Connection

Code	Connection
M3...G1-1/2	M3...G1-1/2

#### 3 – Material

Code	Material
PA	Polyamide

#### 4 – Product addition

Code	Type
Easy-Fix	Internal locking element Easy-Fix

Sealing ring is delivered in the desired diameter.

- Schmalz – The Company
- Vacuum Suction Cups
- Special Grippers
- Gripping Systems
- Clamping Systems
- Mounting Elements
- Vacuum Generators
- Valve Technology
- Switches and Monitoring
- Filters and Connections
- Services
- Contact
- Glossary
- Index of Products



# Sealing Rings DR

For thread from M3 to G1-1/2"



## Ordering Data Sealing Rings DR

Type*	Part no.
DR M3 PA	10.07.08.00018
DR M5 PA	10.07.08.00019
DR G1/8 PA	10.07.08.00020
DR G1/4 PA	10.07.08.00021
DR G3/8 PA	10.07.08.00022
DR G1/2 PA	10.07.08.00023
DR G3/4 PA	10.07.08.00024
DR G1 PA	10.07.08.00025
DR G1-1/4 PA	10.07.08.00026
DR G1-1/2 PA	10.07.08.00027
DR M5 PA Easy-Fix	10.07.08.00245
DR G1/8 PA Easy-Fix	10.07.08.00247
DR G1/4 PA Easy-Fix	10.07.08.00248
DR G3/8 PA Easy-Fix	10.07.08.00249
DR G1/2 PA Easy-Fix	10.07.08.00250
DR G3/4 PA Easy-Fix	10.07.08.00251
DR G1 PA Easy-Fix	10.07.08.00252

\*Sealing ring Easy-Fix with inner centering pins. Ensures optimal sealing. Cannot slip off the thread when the screw connection is opened.



## Design Data Sealing Rings DR

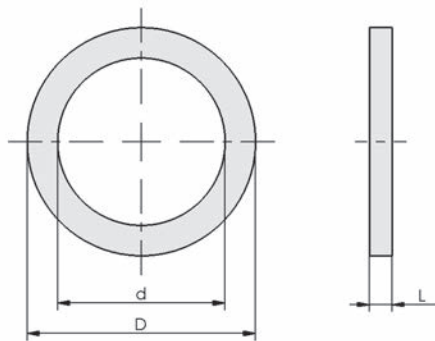

DR

Type	d [mm]	D [mm]	L [mm]
DR M3 PA	3.5	6.0	1.0
DR M5 PA	5.0	8.0	1.2
DR G1/8 PA	10.0	15.0	1.5
DR G1/4 PA	13.5	18.0	1.5
DR G3/8 PA	17.0	22.0	2.0
DR G1/2 PA	21.5	26.0	1.5
DR G3/4 PA	27.0	33.0	2.0
DR G1 PA	34.0	39.0	2.0
DR G1-1/4 PA	42.0	49.0	2.0
DR G1-1/2 PA	48.0	55.0	2.0



# Overview of Sections

	Page	
<b>Services for Your Vacuum System</b>		Schmalz – The Company
<b>Service – Throughout Your Product's Life</b>	670	Vacuum Suction Cups
<b>Complete System Tests and Continuous Operation</b>	671	
<b>Schmalz Training and Test Sets</b>		Special Grippers
<b>Selecting Suitable Vacuum Components for the Packaging Industry</b>	672	
<b>Selecting Suitable Vacuum Components for Other Industries</b>	672	Gripping Systems
<b>Starter Set for Vacuum End Effectors</b>	672	
<b>Schmalz Academy</b>		Clamping Systems
<b>Training Courses and Seminars with a Vacuum Specialist</b>	673	
<b>Schmalz Calculator</b>	674	Mounting Elements

- Schmalz – The Company
- Vacuum Suction Cups
- Special Grippers
- Gripping Systems
- Clamping Systems
- Mounting Elements
- Vacuum Generators
- Valve Technology
- Switches and Monitoring
- Filters and Connections
- Services
- Contact
- Glossary
- Index of Products



# Services

## Services for Your Vacuum System

Benefit from our expertise as system provider and our years of experience as component manufacturer.

A purchase from Schmalz gives you real competitive advantages. Our highly qualified system consultants offer quality advice regarding all your vacuum system needs, from

planning and design to installation, start of operations and even beyond. Thanks to our future-proof approach with a sharp focus on technological innovation and functional performance, Schmalz customers can count on an economical system design and efficient processes throughout the whole product service life.



- Consultation**
- Catalogs
  - Product inquiries
  - CAD data
  - Project planning aids
  - Set-up time optimization



- Procurement**
- Online shop
  - Delivery service
  - Financing / leasing
  - Used devices
  - Test sets



- Start of Operations**
- Project planning
  - Function and durability tests
  - System solutions
  - Design solutions
  - Start-up on site

# Test Center – Function Tests with Original Parts

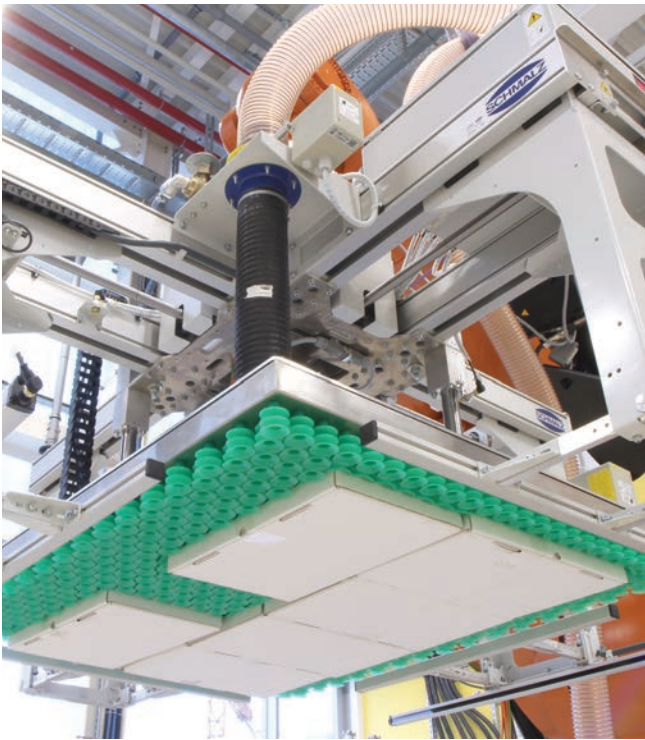

Function tests on a vacuum layer gripping system in the company's own testing laboratory



Standardized durability test cycles on the original workpiece for disruption-free production processes

## FUNCTION TESTS ON ENTIRE SYSTEMS

A part of project planning involves conducting trials with original workpieces. This ensures excellent performance and a high degree of safety. In order to carry out the tests under conditions that are as realistic as possible, Schmalz operates its own test center at its headquarters. There, it identifies potential weak points and solutions.



### Operation

- Maintenance
- Preventative maintenance
- Certified approval
- Energy efficiency
- Spare parts



### Training

- Training courses
- Seminars
- Customer-specific training
- Training materials
- How-to videos



### Repairs

- Emergency service
- Repair service
- Seamless returns management
- Warranty

## ENDURANCE TESTS

Our products are subject to endurance testing as part of their development. For example, suction cups are tested for wear resistance and chemical resistance to various environmental influences. Ejectors are tested for their performance capability and leak-tightness.

Schmalz –  
The Company

Vacuum  
Suction Cups

Special  
Grippers

Gripping  
Systems

Clamping  
Systems

Mounting  
Elements

Vacuum  
Generators

Valve  
Technology

Switches and  
Monitoring

Filters and  
Connections

Services

Contact

Glossary

Index of  
Products

# Schmalz Test Sets

Schmalz – The Company

Vacuum Suction Cups

## Selecting Suitable Vacuum Components for the Packaging Industry

Modern production processes place ever increasing demands on vacuum suction cups. This is especially true in the packaging industry, where specific demands are created by the need to handle extremely different materials such as cardboard boxes of various weights and sizes, blister packs and plastic films.

Special Grippers

With the “suction cups for the packaging industry” test set, Schmalz enables you to quickly choose the best suction cup for your particular application in the packaging industry.

Gripping Systems

The set contains every component you need for the suction test:

- More than 80 vacuum suction cups in various shapes and materials cover almost all applications
- Three ejectors with differing suction rates generate the vacuum directly via a compressed air connection
- A vacuum gauge up to -1 bar, a polyurethane vacuum hose and a number of connectors complete the test set

Clamping Systems

Mounting Elements



### Ordering Data

Type	Part no.
Packaging test set	30.02.03.00226

Vacuum Generators

## Selecting Suitable Vacuum Components for Other Industries

We have also developed suitable test sets for other industries. Contact us to find out more and we will select the appropriate components for your tests from our product range.

Valve Technology

### Schmalz Customer Center

Phone +49 7443 2403-102  
 Fax +49 7443 2403-9102  
 kundencenter@schmalz.de

Switches and Monitoring

## Starter Set for Vacuum End Effectors

Until now, a custom-manufactured gripper for each format was used on packaging machines. Now, with Schmalz system modules, vacuum end effectors can be configured flexibly: the user can assemble end effectors from a range of different flanges, connectors and suction cups, and these can then be quickly modified when required. To make designing the gripper even more straightforward, every element of the modular system can be downloaded as a CAD model from our website. [WWW.SCHMALZ.COM/VEE](http://WWW.SCHMALZ.COM/VEE)

Filters and Connections

Services

With the VEE starter set, you can instantly configure vacuum end effectors for the fastest possible packaging processes.

Contact

Contents:

- 120-piece starter set with all components for assembling up to two vacuum end effectors VEE
- Eight vacuum suction cups SPB4f-30 for bags and other non-rigid types of packaging
- Quick-change adapter with bayonet mount
- Supplied in a sturdy plastic case with detailed assembly instructions

Glossary

Index of Products



### Ordering Data

Type	Part no.
VEE starter set	10.01.36.00030





## Schmalz Imparts Knowledge - Tailored to the Needs of the Employees of Your Company



Qualified, motivated employees with a high level of expertise and technical knowledge are vital for an innovative and competitive business. They form the basis for commercial success. Schmalz imparts knowledge – carefully tailored to meet the needs of your company's employees.

### Training Courses and Seminars with a Vacuum Specialist

Schmalz has extensive knowledge about vacuum technology. The functions and application areas of vacuum components, how these can be used effectively in automation systems and the efficient design and conception of complex vacuum systems, are particular areas of expertise. This gives participants of Schmalz training courses the chance to benefit from years of knowledge and intensive individual support.

Get in touch with us; we would be happy to offer a seminar tailored to your requirements.

You can find our contact information in the chapter "Contact".



- Schmalz – The Company
- Vacuum Suction Cups
- Special Grippers
- Gripping Systems
- Clamping Systems
- Mounting Elements
- Vacuum Generators
- Valve Technology
- Switches and Monitoring
- Filters and Connections
- Services
- Contact
- Glossary
- Index of Products

- Schmalz – The Company
- Vacuum Suction Cups
- Special Grippers
- Gripping Systems
- Clamping Systems
- Mounting Elements
- Vacuum Generators
- Valve Technology
- Switches and Monitoring
- Filters and Connections
- Services
- Contact
- Glossary
- Index of Products

## Schmalz Calculator

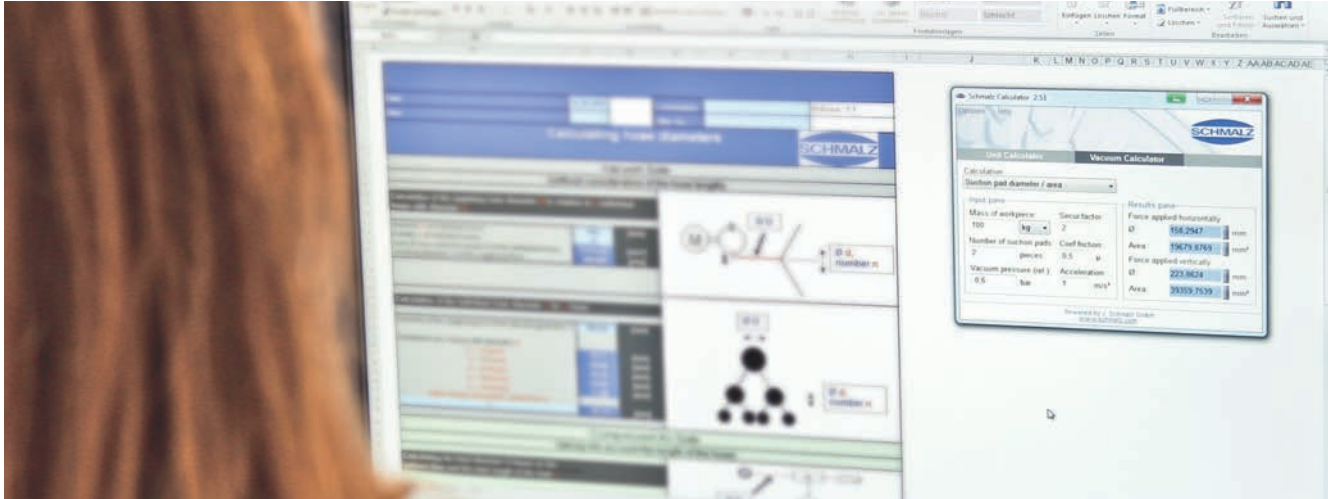

The Schmalz Calculator is a program by Schmalz which is free of charge. It permits easy and quick conversion of system variables and calculations for the design of vacuum systems.

Numerous units and variables are clearly arranged in 14 primary groups on the Schmalz Calculator. These primary groups are located in the "Units Calculator". With just a few clicks, you can

convert units here. For example, you can convert various units in the areas of flow rate, pressure, output, area, time, distance, energy, power, mass, etc. in no time at all.

Calculation of these general variables, however, is only one of the Schmalz Calculator's functions. When solving vacuum specific calculations, the calculator turns out to be the real "expert".

### THE "VACUUM CALCULATOR" PROVIDES YOU WITH INFORMATION ON:

- Evacuation time for pumps
- Suction capacity and area
- Suction force
- Suction capacity for pumps
- Hose diameter

Schmalz's expert knowledge of vacuum technology and its long-time experience in the area of system layouts also form the basis for this calculator's programming. Values for the vacuum sector can hardly be calculated faster and more confidently.

### ADDITIONAL HIGHLIGHTS:

- Frequently used or needed, start and target values can be assigned to the "user-defined" area.
- Custom-created entries are possible, i.e. the user can define a start and target value himself, assign a conversion factor, calculate using this value and/or delete the entries again.
- Decimal places can be set from 0 to 5.
- The Schmalz Calculator contains an integrated help.

Download the Schmalz Calculator free of charge and test it!

# Overview of the Chapter

	Page
<b>Contact to the Vacuum Specialist</b>	
<b>Website</b>	676
<b>International Sales Network</b>	677
<b>General Terms and Conditions of Sale and Delivery and Imprint</b>	678

Schmalz – The Company
Vacuum Suction Cups
Special Grippers
Gripping Systems
Clamping Systems
Mounting Elements
Vacuum Generators
Valve Technology
Switches and Monitoring
Filters and Connections
Services
<b>Contact</b>
Glossary
Index of Products

# Contact Website



Search

Plan

Design

Purchase

Operate

Optimize

## Our Complete Product Portfolio

At [WWW.SCHMALZ.COM](http://WWW.SCHMALZ.COM), you can access our extensive range of products and industry solutions with easy-to-follow and informative video guides.



### Vacuum Technology for Automation

Schmalz vacuum components and gripping systems let you significantly increase productivity in your automated processes.



### Vacuum Lifters and Crane Systems

We offer you handling technology for manual lifting tasks in a huge number of industries to help with your workplace ergonomics.



### Vacuum Clamping Technology

Schmalz offers a wide selection of high-quality clamping equipment for your application.



### Industry Overview

See an overview of the most important product solutions in your sector.

## Comprehensive Tools and Services

Our website provides many tools and services for getting started quickly in the individual areas. They make it quicker and easier to find the right product.



### Online Services for our Customers

A variety of online services such as how-to videos and the Schmalz Calculator help you to select and operate your products.

[WWW.SCHMALZ.COM/ONLINE-SERVICES](http://WWW.SCHMALZ.COM/ONLINE-SERVICES)



### Practical Selection Aids and Configurators

Our selection aids help you to find the right product for your application quickly.

[WWW.SCHMALZ.COM/SELECTION-AIDS](http://WWW.SCHMALZ.COM/SELECTION-AIDS)



### Application Videos

See our vacuum technology in action.

[WWW.SCHMALZ.COM/VIDEOS](http://WWW.SCHMALZ.COM/VIDEOS)



### Catalog Overview

Browse our catalogs or order a printed version free of charge.

[WWW.SCHMALZ.COM/CATALOGS](http://WWW.SCHMALZ.COM/CATALOGS)

### Online Shop

Our helpful online shop makes it easy for you to order more than 6,000 standard components and clamping solutions.



## Schmalz Online-Shop

[WWW.SCHMALZ.COM](http://WWW.SCHMALZ.COM)



Schmalz – The Company  
Vacuum Suction Cups  
Special Grippers  
Gripping Systems  
Clamping Systems  
Mounting Elements  
Vacuum Generators  
Valve Technology  
Switches and Monitoring  
Filters and Connections  
Services  
Contact  
Glossary  
Index of Products

# International Sales Network



## GERMANY

(Headquarters)

J. Schmalz GmbH  
 Johannes-Schmalz-Str. 1  
 72293 Glatten  
 T: +49 7443 2403-0  
 F: +49 7443 2403-259  
 schmalz@schmalz.de

## AUSTRALIA

Millsom Hoists Pty. Ltd.  
 A Schmalz Company  
 25 Turbo Drive  
 Bayswater North VIC 3153  
 T: +61 3 9215 8800  
 F: +61 3 9720 7879  
 schmalz@schmalz.com.au

## CANADA

Schmalz Vacuum Technology Ltd.  
 14-2900 Argentia Rd.  
 L5N 7X9 Mississauga; Ontario  
 T: +1 905 569 9520  
 F: +1 905 569 8256  
 schmalz@schmalz.ca

## CHINA

Schmalz (Shanghai) Co. Ltd.  
 No. 1 Chunquan Road  
 201210 Pudong, Shanghai  
 T: +86 21 510999 33  
 F: +86 21 503988 82  
 schmalz@schmalz.net.cn

## FINLAND

Oy Schmalz Ab  
 Hakkilankaari 2  
 01380 VANTAA  
 T: +358 10 2312011  
 F: +358 9 85746 94  
 schmalz@schmalz.fi

## FRANCE

Schmalz S.A.S.  
 Le Prométhée  
 65 Avenue du Général de Gaulle  
 77420 Champs-sur-Marne  
 T: +33 1 6473 1730  
 F: +33 1 6006 6371  
 schmalz@schmalz.fr

## INDIA

Schmalz India Pvt. Ltd.  
 EL – 38 'J' Block MIDC  
 Bhosari  
 411026 Pune  
 T: +91 20 4072 5500  
 F: +91 20 4072 5588  
 schmalz@schmalz.co.in

## ITALY

Schmalz S.r.l. a Socio Unico  
 Via delle Americhe 1  
 28100 Novara  
 T: +39 0321 621 510  
 F: +39 0321 621 714  
 schmalz@schmalz.it

## JAPAN

Schmalz K.K.  
 3001-7 Odana-cho  
 Tsuzuki-ku  
 JP-224-0027 Yokohama  
 T: +81 45 565 5150  
 F: +81 45 565 5151  
 schmalz@schmalz.co.jp

## MEXICO

Schmalz S. de R.L. de C.V.  
 Pirineos 500, Bodega 18  
 Parque Industrial Benito Juarez  
 Micro Parque Santiago II  
 76120 Querétaro  
 T: +52 442 209 5218  
 schmalz@schmalz.com.mx

## NETHERLANDS

Schmalz B.V.  
 Generatorstraat 34  
 7556 RC Hengelo  
 T: +31 74 25557 57  
 F: +31 74 25557 58  
 schmalz@schmalz.nl

## POLAND

Schmalz Sp.z.o.o.  
 Ul. Kobaltowa 4, Złotniki  
 62-002 Suchy Las (Poznan)  
 T: +48 22 460 49 72  
 F: +48 22 460 49 79  
 schmalz@schmalz.pl

## RUSSIA

OOO Schmalz  
 Mozhayskoe highway 165, bdg 1  
 121596, Moscow  
 T: +7 495 96712 48  
 F: +7 495 96712 49  
 schmalz@schmalz.ru

## SOUTH KOREA

Schmalz Co. Ltd.  
 1412 O-Biz Tower  
 Beolmal St. 126, Dongan-gu  
 Anyang-si, Gyeonggi-do  
 T: +82 31 816 2403  
 F: +82 31 816 2404  
 schmalz@schmalz.co.kr

## SPAIN

Schmalz S.A.  
 Avda. Ribera de Axpe. 49  
 P.A.E. UDONDO-Edificio B-Nave 2  
 48950 Erandio (Vizcaya)  
 T: +34 94 480 5585  
 F: +34 94 480 7264  
 schmalz@schmalz.es

## SWITZERLAND

Schmalz GmbH  
 Eigentlstrasse 1  
 8309 Nürens Dorf  
 T: +41 44 88875 25  
 F: +41 44 88875 29  
 schmalz@schmalz.ch

## TURKEY

Schmalz Vakum  
 San. ve Tic. Ltd. Şti.  
 Aydınlı Mah. Patlayıcı  
 Maddeler Yolu  
 Dumankaya Botanik A-89  
 34953-TUZLA-ISTANBUL  
 T: +90 216 34001 21  
 F: +90 216 34001 24  
 schmalz@schmalz.com.tr

## UNITED STATES

Schmalz Inc.  
 5850 Oak Forest Drive  
 Raleigh, NC 27616  
 T: +1 919 71308 80  
 F: +1 919 71308 83  
 schmalz@schmalz.us

You can find the Schmalz sales partner in your country at: [WWW.SCHMALZ.COM/SALESNETWORK](http://WWW.SCHMALZ.COM/SALESNETWORK)





# General Terms and Conditions of Sale and Delivery and Imprint

Schmalz – The Company

Vacuum Suction Cups

Special Grippers

Gripping Systems

Clamping Systems

Mounting Elements

Vacuum Generators

Valve Technology

Switches and Monitoring

Filters and Connections

Services

Contact

Glossary

Index of Products

IMPRINT  
VACUUM AUTOMATION  
COMPONENTS CATALOG

Printed on: 07/2018

All contents and technical data were correct when the catalog went into print. Great care has been taken in the compilation of the catalog and all technical and other information was thoroughly checked. However, Schmalz accepts no liability for faulty or incomplete information, mistakes or printing errors.

Schmalz reserves the right to make changes for the sake of the further product development.

Schmalz shall not be held liable for size variation resulting from production and the materials used.

All contents, images, drawings and data included in this catalog are property of J. Schmalz GmbH and are protected by copyright. Any reproduction, modification, translation, microfilming or manipulation of the contents without permission from J. Schmalz GmbH is forbidden.

All contractual relationships, orders and purchase agreements are subject to our general terms of sale and delivery. A current version of our sales and delivery agreement is available at [WWW.SCHMALZ.COM/TERMS](http://WWW.SCHMALZ.COM/TERMS).

Publisher:

J. Schmalz GmbH  
Johannes-Schmalz-Str. 1  
72293 Glatten, Germany  
T: +49 7443 2403-0  
F: +49 7443 2403-259  
[schmalz@schmalz.de](mailto:schmalz@schmalz.de)  
[WWW.SCHMALZ.COM](http://WWW.SCHMALZ.COM)

## GENERAL TERMS AND CONDITIONS OF SALE AND DELIVERY

All prices and benefits are based on the general business terms and conditions which can be downloaded from our website [WWW.SCHMALZ.COM/TERMS](http://WWW.SCHMALZ.COM/TERMS) or requested directly from us.



**Glossary**

Page

**Technical Terms of the Vacuum Technology**

680

Schmalz –  
The Company

Vacuum  
Suction Cups

Special  
Grippers

Gripping  
Systems

Clamping  
Systems

Mounting  
Elements

Vacuum  
Generators

Valve  
Technology

Switches and  
Monitoring

Filters and  
Connections

Services

Contact

**Glossary**

Index of  
Products



# Technical Terms of the Vacuum Technology

Schmalz –  
The CompanyVacuum  
Suction Cups**ABRASION RESISTANCE**

The abrasion resistance refers to the resistance of suction cups (elastomer part) against mechanical stress, especially friction. It is determined by the material properties of the suction cup as well as its shape.

Special  
Grippers**ABSOLUTE PRESSURE**

The absolute pressure refers to the absolute zero point, or a space completely empty of molecules. In an absolute vacuum there is a pressure of 0 bar. A relative vacuum of -600 mbar corresponds to an absolute pressure of 400 mbar.

Gripping  
Systems**AIR-SAVING FUNCTION**

Air-saving function refers to the ejector's function to save compressed air during the handling procedure. Once the ejector reaches a particular vacuum value, the evacuation process is interrupted. If the vacuum drops below a defined value, the ejector starts evacuating again. The air-saving function can therefore increase the energy and economic efficiency of a vacuum system.

Clamping  
SystemsMounting  
Elements**AMBIENT PRESSURE (atmospheric pressure)**

Ambient pressure refers to the hydrostatic pressure that exists at any given point. Ambient pressure is also known as atmospheric pressure. The standard atmospheric pressure at sea level is 1,013 mbar. The ambient pressure drops with increasing altitude. At an altitude of 600 m (the location of J. Schmalz GmbH in Glatten, Germany) the ambient pressure is reduced to 938 mbar. The ambient pressure has a direct influence on the maximum vacuum value that can be reached.

Vacuum  
GeneratorsValve  
Technology**BERNOULLI'S PRINCIPLE**

Bernoulli's principle describes the drop in pressure of a fluid when it passes from a narrow section to a much wider section. In practice, this happens in the form of a direct transition into an open space. To prevent the vacuum collapsing, the fluid is diverted to the side.

Switches and  
MonitoringFilters and  
Connections**CENTRALIZED VACUUM SYSTEM**

In a centralized vacuum system, the vacuum is generated with a central vacuum source for more than one suction cup.

Services

**CHECK VALVE**

The check valve automatically monitors volume flow. If the volume flow exceeds a defined value, the valve closes automatically; for example, when suction cups are not being used.

Contact

**CONTROL PRESSURE RANGE**

The control pressure range is the range between the lowest and highest permissible control pressures.

Glossary

**CYCLE TIME**

The cycle time refers to the time taken for a repetitive process to complete one cycle.

Index of  
Products**DECENTRALIZED VACUUM SYSTEM**

In a decentralized vacuum system, vacuum is generated directly at each individual vacuum suction cup. Positioning vacuum generation directly at the suction cup allows for short pick-up and depositing times.

**EVACUATION TIME**

The evacuation time refers to the time it takes to evacuate a certain volume in order to reach the required vacuum value.

**FLOW RESISTANCE**

Flow resistance refers to a reduced flow cross-section in a vacuum line. The resistance reduces the volume flow that can pass through a line.

**FRICTION COEFFICIENT**

The friction coefficient [ $\mu$ ] refers to the relation between friction force and normal force (contact force between suction cup and workpiece). The friction coefficient is not specified by an unit.

**HIGH VACUUM**

A high vacuum describes any vacuum in which there is an absolute pressure of  $10^{-7}$  to  $10^{-3}$  mbar. High vacuums are used, for example, in electron tubes and particle accelerators.

**HOLDING FORCE**

Holding force refers to the force that can be exerted by a suction cup to grip a workpiece. It is calculated by multiplying the pressure difference by the effective suction area of the suction cup ( $F = \Delta p \times A$ ). The holding force of a suction cup is thus influenced by underpressure and the suction area. It is a theoretical value, specified without safety factors. It is usual to state the holding force of a suction cup with a relative vacuum of 60 %.

**HYSTERESIS**

Hysteresis refers to a pressure difference between two switching points, and thus defines the state of the output signal. The respective output signal changes when either the upper or lower limit value of the hysteresis is reached. Using the example of a vacuum switch: When the vacuum reaches a specified value, the signal changes to "ON". If the vacuum drops below a defined value, the signal switches to "OFF". Hysteresis is mainly used to control the air-saving function of ejectors.

**IDLE POSITION OF NC VALVE**

The idle position of an NC valve refers to the position of the valve when it is not actuated, i.e. "closed" (normally closed).

**IDLE POSITION OF NO VALVE**

The idle position of an NO valve refers to the position of the valve when it is not actuated, i.e. "open" (normally open).



# Technical Terms of the Vacuum Technology

## INNER VOLUME

The inner volume indicates the volume of the body that has to be evacuated during a suction procedure. For example, the inner volume of a suction cup has an effect on the evacuation time.

## IO-LINK

IO-Link is used for bidirectional communication with all common fieldbus systems. This enables remote parameterization and remote diagnostics.

## LEAKAGE

Leakage refers to a leak within the vacuum system. This can be caused by missing or faulty sealing elements, or by the porosity of the workpiece being processed.

## LOAD CASE

Load case refers to the handling task, or the process of handling a workpiece.

Load case I – Suction cup horizontal, direction of force vertical

Load case II – Suction cup horizontal, direction of force horizontal

Load case III – Suction cup vertical, direction of force vertical

## LOW VACUUM

A low vacuum describes any vacuum in which there is an absolute pressure of 1 mbar up to atmospheric pressure (1,013 mbar). Examples of applications for a low vacuum include light bulbs and vacuum cleaners. Vacuum handling technology also uses values in the low vacuum range because these can be generated economically to create high suction power and short cycle times.

## MEDIUM VACUUM

A medium vacuum describes any vacuum in which there is an absolute pressure between 0.001 mbar and 1 mbar. Medium vacuum is used, for example, in low-pressure gas-filled lights.

## MINIMUM RADIUS OF CURVATURE

The minimum radius of curvature refers to the smallest radius that a suction cup can securely grip. For round suction cups, this refers to a sphere, while for oval suction cups it refers to a cylinder.

## NFC TECHNOLOGY

NFC technology (Near Field Communication) enables contactless communication over a point-to-point connection between a product and a mobile device such as a smartphone. It is possible to read out data as well as parameterize it.

## NOMINAL FLOW

Nominal flow refers to the maximum flow through a certain diameter (nominal diameter). The nominal flow is given in l/min or m<sup>3</sup>/h.

## NORMAL FORCE

Normal force is the force component acting perpendicular to a surface. Every force acting on a surface can be divided into normal force and shear force (see "Shear force"). Based on the

normal force, the friction force can be calculated using the friction coefficient for a material pairing. The result indicates the friction force between two surfaces, for example between a suction cup and a workpiece. Normal force is measured in Newton [N].

## NPN – SWITCHING OUTPUT

NPN switching output refers to the configuration of a switching output in cases where the load is connected to the positive pole of the operating voltage source. The output transistor of the vacuum switch connects the active device through to the operating voltage, allowing current to flow through the consuming device.

## OPERATING TEMPERATURE

The operating temperature is the temperature range in which a product can be deployed or run.

## OVERPRESSURE RESISTANCE

Overpressure resistance refers to the maximum pressure that a body (for example, a reservoir or vacuum filter) can resist.

## PNP SWITCHING OUTPUT

PNP switching output refers to the configuration of a switching output in cases where the load has a permanent connection to the operating voltage source. The output transistor of the vacuum switch connects the active device to the positive pole, allowing current to flow through the consuming device.

## RECOVERY TIME

The recovery time is the period in which the product is not being used or is not subject to significant work loads. The product can recover during this time.

## REFERENCE PRESSURE

Reference pressure is the pressure referred to by a sensor. Vacuum switches, for example, have a connection for reference air.

## RELATIVE PRESSURE

Relative pressure refers to the value of pressure in relation to the prevalent ambient pressure. The vacuum is given using negative values. Relative pressure has a pressure of 0 mbar as a reference point. An absolute pressure of 400 mbar corresponds to a relative pressure of -600 mbar. In the field of vacuum handling, it is also common to state the values in percentages: -600 mbar corresponds to a vacuum of 60 %.

## REVERSING VALVE

A reversing valve is a type of changeover valve used in a blower. The valve supplies the system alternately with overpressure and underpressure. The valve thus controls the suction, blow off and neutral setting in the vacuum system.

## SHEAR FORCE

Shear force is the force acting tangentially to a surface and indicates how much friction can be transferred between the suction cup and workpiece. Shear force is given in Newton [N].

# Technical Terms of the Vacuum Technology

Schmalz – The Company
Vacuum Suction Cups
Special Grippers
Gripping Systems
Clamping Systems
Mounting Elements
Vacuum Generators
Valve Technology
Switches and Monitoring
Filters and Connections
Services
Contact
Glossary
Index of Products

## SHORE HARDNESS

Shore hardness refers to the hardness of elastomers and plastics. It is a standardized material property for the hardness of materials.

## STANDARD LITER

A standard liter is the measurement of a gas occupying a liter at 20° C and 1,013 mbar (standard state).

## STANDARD PRESSURE

Standard pressure is the pressure in the atmosphere under standard conditions. In both technology and the natural sciences, this is 1,013 mbar at 0° C. The values in the Schmalz catalog refer to a temperature of 20° C.

## STANDARD TEMPERATURE

Standard temperature is the temperature under standard conditions. The values in the Schmalz catalog refer to a temperature of 20° C.

## SUCTION FORCE

See "Holding force"

## SUCTION CUP STROKE

The suction cup stroke refers to the stroke effect that is created by the suction cup when picking up a workpiece. The stroke value indicates the maximum contraction of the suction cup.

## SUCTION POWER

See "Suction rate"

## SUCTION RATE

Suction rate refers to the suction power of a vacuum generator. This value indicates the volume that can be evacuated by a vacuum generator in a certain time. The suction rate is given in l/min or m<sup>3</sup>/h.

## SWITCHING POINT

The switching point refers to a point at which a switch changes the state of the output signal.

If, for example, a programmed vacuum value is reached on a vacuum switch, the output signal switches to "ON" and there is voltage at the switch output.

The initial position of the signal can be set to either NC (opener) or NO (closer).

## VACUUM

A vacuum is a pressure range lower than that of the ambient pressure. The vacuum value is divided into various classes; refer to "High Vacuum", "Medium Vacuum" and "Low Vacuum".

## VENTILATION TIME

The ventilation time refers to the time it takes to release vacuum in a system. This defines the time it takes to release a workpiece. A suction cup can be ventilated either atmospherically or actively by a compressed air pulse (active blow off).

## VENTURI PRINCIPLE

The Venturi principle describes the correlation between dynamic and static air pressure when air flows through a tube. At the narrowest section, the dynamic pressure is at a maximum, while the static pressure is at a minimum. Since the same volume is flowing through the tube, the velocity increases in proportion to the cross sections. Because of this differential pressure, a vacuum can be created and air can be drawn in by using Venturi nozzles with a side inlet port. Vacuum generators based on this principle are called ejectors.

## VOLUME FLOW

Volume flow refers to the volume of a medium that flows through a cross section within a certain amount of time. Volume flow is given in l/min or m<sup>3</sup>/h.

## WORKPIECE TEMPERATURE

The workpiece temperature is the temperature of a processed workpiece. This temperature can influence the selection of a suitable suction cup material.

## Vacuum Knowledge for Automation

- Our vacuum knowledge provides a well-founded overview of the functions and applications of vacuum components as well as the design of complex vacuum systems
- Obtain a sound basic knowledge of vacuum technology in automation

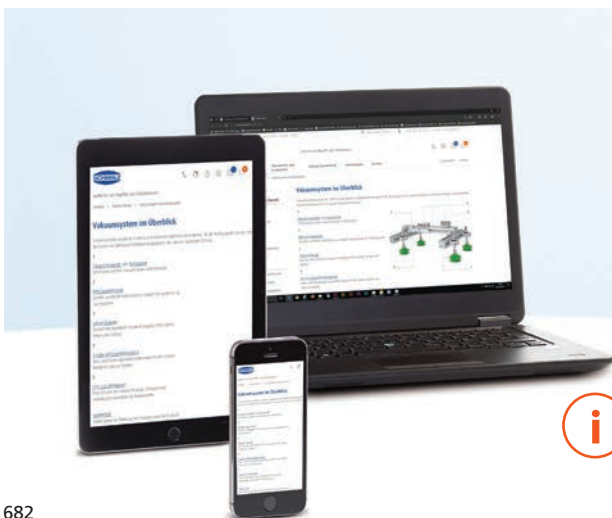

[WWW.SCHMALZ.COM/VACUUM-KNOWLEDGE](http://WWW.SCHMALZ.COM/VACUUM-KNOWLEDGE)

Sorted alphabetically

Designation	Type	Page	Designation	Type	Page	Schmalz – The Company
<b>A</b>						
Adapters for Elbow Connector ANW	ANW	396	Clamping Equipment for Schmalz Consoles (two-circuit)	VCBL-K2	336	Vacuum Suction Cups
Area Gripping Systems FM-SW	FM-SW	315	Compact Ejectors SEM-C	SEM-C	506	
Area Gripping Systems FMHD	FMHD	311	Compact Ejectors SCPM	SCPM	502	Special Grippers
Area Gripping Systems FMP	FMP	303	Compact Ejectors SCPS / SCPSi	SCPS / SCPSi	486	
Area Gripping Systems FX-SW	FX-SW	312	Compact Ejectors SCPSb	SCPSb	480	Gripping Systems
Area Gripping Systems FXP	FXP	296	Compact Ejectors SCPI / SMPi	SCPI / SMPi	497	
Area Gripping Systems SBX-C with Ejector	SBX-C	320	Compact Ejectors X-Pump SXPi / SXMPi with IO-Link	SXPi / SXMPi	492	Clamping Systems
Area Gripping Systems SBX-C without Ejector	SBX-C	323	Compact Terminal SCTMi	SCTMi	512	
<b>B</b>						
Ball Joints KGL	KGL	357	<b>D</b>			Gripping Systems
Basic Ejectors SBP	SBP	441	Dry-Running Vacuum Pumps EVE-TR	EVE-TR	518	
Basic Ejectors SBP-C with Additional Functions	SBP-C	446	Dry-Running Vacuum Pumps EVE-TR X	EVE-TR X	526	Clamping Systems
Basic Ejectors SBP-HV/HF	SBP-HV/HF	454	<b>E</b>			
Basic Ejectors SBPL	SBPL	427	Ejector Modules ecoPump SEP	SEP	421	Mounting Elements
Basic Ejectors SEG	SEG	435	Ejectors with Active Blow Off SEAC	SEAC	468	
Basic Holding Fixture BHF	BHF	347	Ejectors with Atmospheric Ventilation SEAC ECO	SEAC ECO	476	Vacuum Generators
Bell-Shaped Suction Cups SAOXM (Oval)	SAOXM	101	Ejectors with Blow Off System SEAC RP	SEAC RP	472	
Bell-Shaped Suction Cups SAX	SAX	97	Electric Needle Grippers SNGi-AE	SNGi-AE	256	Valve Technology
Bellows Suction Cups FG PVC (2.5 Folds)	FG PVC	177	<b>F</b>			
Bellows Suction Cups FGA PVC (1.5 Folds)	FGA PVC	174	Feed Ejectors SEC	SEC	282	Switches and Monitoring
Bellows Suction Cups FSG (2.5 Folds)	FSG	83	Filter Discs FD	FD	225	
Bellows Suction Cups FSG VU1 (2.5 Folds)	FSG VU1	90	Flat Suction Cups PFYN	PFYN	36	Filters and Connections
Bellows Suction Cups FSGA (1.5 Folds)	FSGA	66	Flat Suction Cups PFYN VU1	PFYN VU1	44	
Bellows Suction Cups FSGA (1.5 Folds) from Ø110 mm	FSGA	77	Flat Suction Cups SAF	SAF	106	Services
Bellows Suction Cups FSGA VU1 (1.5 Folds)	FSGA VU1	72	Flat Suction Cups SAF HT2	SAF HT2	200	
Bellows Suction Cups FSGAO (1.5 Folds)	FSGAO	94	Flat Suction Cups SAOF (Oval)	SAOF	114	Contact
Bellows Suction Cups FSGPL (1.5 Folds)	FSGPL	80	Flat Suction Cups SAOF HT2 (Oval)	SAOF HT2	206	
Bellows Suction Cups SAB (1.5 Folds)	SAB	110	Flat Suction Cups SGON	SGON	56	Glossary
Bellows Suction Cups SAB HT1 (1.5 Folds)	SAB HT1	193	Flat Suction Cups SGPN	SGPN	183	
Bellows Suction Cups SAB HT2 (1.5 Folds)	SAB HT2	203	Flat Suction Cups SHFN	SHFN	125	Index of Products
Bellows Suction Cups SAB2 P (2.5 Folds)	SAB2 P	122	Flat Suction Cups SPF	SPF	134	
Bellows Suction Cups SAOB (Oval, 1.5 Folds)	SAOB	118	Flexolink FLK	FLK	354	Index of Products
Bellows Suction Cups SAOB HT1 (Oval, 1.5 Folds)	SAOB HT1	197	Floating Suction Cups SBS	SBS	243	
Bellows Suction Cups SAOB HT2 (Oval, 1.5 Folds)	SAOB HT2	209	Flow Grippers SCG	SCG	274	Index of Products
Bellows Suction Cups SPB1 (1.5 Folds)	SPB1	139	Flow Restrictors SW	SW	584	
Bellows Suction Cups SPB2 (2.5 Folds)	SPB2	149	<b>H</b>			Index of Products
Bellows Suction Cups SPB2 P (2.5 Folds) Flow Restrictor	SPB2 P	153	Holders for Light-Metal Sections HTR-STA	HTR-STA	401	
Bellows Suction Cups SPB2f (2.5 Folds)	SPB2f	165	Holders for Square Tubes HTR-STS	HTR-STS	403	Index of Products
Bellows Suction Cups SPB4 (4.5 Folds)	SPB4	156	Hose Clamps SSB / SSD	SSB / SSD	653	
Bellows Suction Cups SPB4f (4.5 Folds)	SPB4f	169	<b>I</b>			Index of Products
Bellows Suction Cups SPOB1 (Oval, 1.5 Folds)	SPOB1	145	Inline Ejectors SLP	SLP	460	
Bellows Suction Cups SPOB1f (Oval, 1.5 Folds)	SPOB1f	161	Inline Ejectors VR	VR	464	Index of Products
Bulkhead Connectors SVS-GE	SVS-GE	399	Inline Filters VFI	VFI	644	
<b>C</b>						
Check Valves SVK, SVKG, SVV	SVK, SVKG, SVV	578	Inline Valves IV	IV	563	Index of Products
Check Valves SVN	SVN	581	Innospann Steel-Plate ISST	ISST	340	
Chocolate Suction Cups SPG	SPG	180	Innospann Steel-Plate Systems ISST-MPL	ISST-MPL	346	Index of Products
Clamping Equipment for Biesse consoles	VCBL-B	337	<b>M</b>			
Clamping Equipment for Grid Tables	VCBL-R	339	Magnetic Grippers SGM	SGM	248	Index of Products
Clamping Equipment for SCM / Morbidelli Consoles	VCBL-S	338	Magnetic Grippers SGM-HP/-HT	SGM-HP/-HT	252	
Clamping Equipment for Schmalz Consoles (single-circuit)	VCBL-K1	335				

Sorted alphabetically

	Designation	Type	Page	Designation	Type	Page
Schmalz – The Company				<b>T</b>		
Vacuum Suction Cups	Manometer VAM-D	VAM-D	628	Thin Glass Grippers STGG	STGG	278
	Manometers VAM	VAM	625	Three-Way Ball Valves KVD	KVD	594
	Manual Slide Valves HSV	HSV	596	Touch Valves TV / TVN	TV / TVN	587
	Matrix-Plate MPL	MPL	345	Two-Way Ball Valves KVZ	KVZ	592
	Mounting Sections MO-PROF	MO-PROF	409			
Special Grippers	Multi-Clamp VC-M	VC-M	344	<b>U</b>		
				Universal Holders HTR-UNI	HTR-UNI	406
	<b>N</b>			<b>V</b>		
Gripping Systems	Needle Grippers SNG-AP	SNG-AP	259	Vacuum / Compressed Air Distributors VTR	VTR	647
	Needle Grippers SNG-M	SNG-M	266	Vacuum / Compressed Air Hoses VSL	VSL	649
	Needle Grippers SNG-V	SNG-V	262	Vacuum Blocks VCBL-G	VCBL-G	341
	Non-Return Valves RSV	RSV	590	Vacuum Blocks VCBL-GL	VCBL-GL	342
				Vacuum Blowers SB	SB	541
Clamping Systems	<b>O</b>			Vacuum Blowers SGBL-DG	SGBL-DG	535
	Oil-Lubricated Vacuum Pumps EVE-OG	EVE-OG	527	Vacuum Centres VZ	VZ	534
				Vacuum Cup Filters VFT	VFT	641
	<b>P</b>			Vacuum End Effectors VEE	VEE	328
Mounting Elements	Pressure-Reduction Valves DM	DM	630	Vacuum Filters VF / STF / STF-D	VF / STF / STF-D	638
	Protection Covers PC	PC	233	Vacuum Generator ECBPi	ECBPi	549
				Vacuum Layer Gripping System SPZ	SPZ	326
	<b>S</b>			Vacuum Operation Center VOC	VOC	555
Vacuum Generators	Schmalz Quick-Change SQC	SQC	343	Vacuum Regulators VR	VR	623
	Screw in Push Fittings	STV	656	Vacuum Reservoirs VOL	VOL	533
	Sealing Cords DI-SCHN	DI-SCHN	219	Vacuum Sensor VS-V-SA	VS-V-SA	605
	Sealing Profiles DI-PROF	DI-PROF	221	Vacuum Switches VS-V-PM/EM-ST	VS-V-PM/EM-ST	602
	Sealing Rings DR	DR	667	Vacuum Switches VS-V-SD	VS-V-SD	618
Valve Technology	Sealing Rings DR-MOS SI	DR-MOS SI	230	Vacuum Unit VAGG	VAGG	552
	Solenoid Valves EMV	EMV	566	Vacuum and Pressure Sensors VS	VS	609
	Solenoid Valves EMVO	EMVO	570	Vacuum and Pressure Switches VS-V/P-AH/AV-T	VS-V/P-AH/AV-T	620
	Solenoid Valves EMVP	EMVP	565	Vacuum and Pressure Switches VS-V/P-W-D-K(-2C)	VS-V/P-W-D-K(-2C)	614
Switches and Monitoring	Spring Plungers FSTA	FSTA	375	Vacuum and Pressure Switches VSi	VSi	611
	Spring Plungers FSTA-HD	FSTA-HD	378			
	Spring Plungers FSTE	FSTE	364	<b>W</b>		
	Spring Plungers FSTE-HD	FSTE-HD	368	Wafer Grippers SWGm	SWGm	269
	Spring Plungers FSTE-HDB	FSTE-HDB	372			
Filters and Connections	Spring Plungers FSTF	FSTF	385			
	Spring Plungers FSTI	FSTI	381			
	Spring Plungers FSTIm	FSTIm	360			
	Suction Cup Covers SU	SU	230			
	Suction Cup Inserts SPI PEEK	SPI PEEK	228			
Services	Suction Plates SGF	SGF	188			
	Suction Plates SHF	SHF	131			
	Suction Plates SPK	SPK	53			
	Suction Plates SPL POM-NBR	SPL POM-NBR	217			
Contact	Suction Plates SPLO	SPLO	62			
	Suction Plates SPU	SPU	48			
	Suction Plates for High-Temperature SPL-HT	SPL-HT	215			
	Suction Plates for High-Temperature SPL-HT FPM-F	SPL-HT FPM-F	212			
	Suction Spiders SSP	SSP	327			
Glossary	Suction-Cup Balance SSCB	SSCB	285			
	Suspension Flexible FST-FLEX	FST-FLEX	388			
Index of Products	Suspension rigid FST-STARR	FST-STARR	392			

Sorted alphabetically

Type	Designation	Page	Type	Designation	Page	Schmalz – The Company
<b>A</b>			<b>I</b>			
ANW	Adapters for Elbow Connector ANW	396	ISST	Innospann Steel-Plate ISST	340	Vacuum Suction Cups
			ISST-MPL	Innospann Steel-Plate Systems ISST-MPL	346	
			IV	Inline Valves IV	563	
<b>B</b>			<b>K</b>			
BHF	Basic Holding Fixture BHF	347	KGL	Ball Joints KGL	357	Special Grippers
			KVD	Three-Way Ball Valves KVD	594	
			KVZ	Two-Way Ball Valves KVZ	592	
<b>D</b>			<b>M</b>			
DI-PROF	Sealing Profiles DI-PROF	221	MO-PROF	Mounting Sections MO-PROF	409	Gripping Systems
DI-SCHN	Sealing Cords DI-SCHN	219	MPL	Matrix-Plate MPL	345	
DM	Pressure-Reduction Valves DM	630				
DR	Sealing Rings DR	667	<b>P</b>			
DR-MOS SI	Sealing Rings DR-MOS SI	230	PC	Protection Covers PC	233	Clamping Systems
			PFYN	Flat Suction Cups PFYN	36	
<b>E</b>			PFYN VU1	Flat Suction Cups PFYN VU1	44	
ECBPi	Vacuum Generator ECBPi	549	<b>R</b>			
EMV	Solenoid Valves EMV	566	RSV	Non-Return Valves RSV	590	Mounting Elements
EMVO	Solenoid Valves EMVO	570				
EMVP	Solenoid Valves EMVP	565	<b>S</b>			
EVE-OG	Oil-Lubricated Vacuum Pumps EVE-OG	527	SAB	Bellows Suction Cups SAB (1.5 Folds)	110	Vacuum Generators
EVE-TR	Dry-Running Vacuum Pumps EVE-TR	518	SAB HT1	Bellows Suction Cups SAB HT1 (1.5 Folds)	193	
EVE-TR X	Dry-Running Vacuum Pumps EVE-TR X	526	SAB HT2	Bellows Suction Cups SAB HT2 (1.5 Folds)	203	
<b>F</b>			SAB2 P	Bellows Suction Cups SAB2 P (2.5 Folds)	122	
FD	Filter Discs FD	225	SAF	Flat Suction Cups SAF	106	Valve Technology
FG PVC	Bellows Suction Cups FG PVC (2.5 Folds)	177	SAF HT2	Flat Suction Cups SAF HT2	200	
FGA PVC	Bellows Suction Cups FGA PVC (1.5 Folds)	174	SAOB	Bellows Suction Cups SAOB (Oval, 1.5 Folds)	118	Valve Technology
FLK	Flexolink FLK	354	SAOB HT1	Bellows Suction Cups SAOB HT1 (Oval, 1.5 Folds)	197	
FM-SW	Area Gripping Systems FM-SW	315	SAOB HT2	Bellows Suction Cups SAOB HT2 (Oval, 1.5 Folds)	209	
FMHD	Area Gripping Systems FMHD	311	SAOF	Flat Suction Cups SAOF (Oval)	114	Switches and Monitoring
FMP	Area Gripping Systems FMP	303	SAOF HT2	Flat Suction Cups SAOF HT2 (Oval)	206	
FSG	Bellows Suction Cups FSG (2.5 Folds)	83	SAOXM	Bell-Shaped Suction Cups SAOXM (Oval)	101	Switches and Monitoring
FSG VU1	Bellows Suction Cups FSG VU1 (2.5 Folds)	90	SAX	Bell-Shaped Suction Cups SAX	97	
FSGA	Bellows Suction Cups FSGA (1.5 Folds)	66	SB	Vacuum Blowers SB	541	Filters and Connections
FSGA	Bellows Suction Cups FSGA (1.5 Folds) from Ø110 mm	77	SBP	Basic Ejectors SBP	441	
FSGA VU1	Bellows Suction Cups FSGA VU1 (1.5 Folds)	72	SBP-C	Basic Ejectors SBP-C with Additional Functions	446	Filters and Connections
FSGAO	Bellows Suction Cups FSGAO (1.5 Folds)	94	SBP-HV/HF	Basic Ejectors SBP-HV/HF	454	
FSGPL	Bellows Suction Cups FSGPL (1.5 Folds)	80	SBPL	Basic Ejectors SBPL	427	Services
FST-FLEX	Suspension Flexible FST-FLEX	388	SBS	Floating Suction Cups SBS	243	
FST-STARR	Suspension rigid FST-STARR	392	SBX-C	Area Gripping Systems SBX-C with Ejector	320	Services
FSTA	Spring Plungers FSTA	375	SBX-C	Area Gripping Systems SBX-C without Ejector	323	
FSTA-HD	Spring Plungers FSTA-HD	378	SCG	Flow Grippers SCG	274	Contact
FSTE	Spring Plungers FSTE	364	SCPM	Compact Ejectors SCPM	502	
FSTE-HD	Spring Plungers FSTE-HD	368	SCPS / SCPSi	Compact Ejectors SCPS / SCPSi	486	Contact
FSTE-HDB	Spring Plungers FSTE-HDB	372	SCPSb	Compact Ejectors SCPSb	480	
FSTF	Spring Plungers FSTF	385	SCPi / SMPi	Compact Ejectors SCPi / SMPi	497	Glossary
FSTI	Spring Plungers FSTI	381	SCTMi	Compact Terminal SCTMi	512	
FSTIm	Spring Plungers FSTIm	360	SEAC	Ejectors with Active Blow Off SEAC	468	Glossary
FX-SW	Area Gripping Systems FX-SW	312	SEAC ECO	Ejectors with Atmospheric Ventilation SEAC ECO	476	
FXP	Area Gripping Systems FXP	296	SEAC RP	Ejectors with Blow Off System SEAC RP	472	Index of Products
<b>H</b>			SEC	Feed Ejectors SEC	282	
HSV	Manual Slide Valves HSV	596	SEG	Basic Ejectors SEG	435	
HTR-STA	Holders for Light-Metal Sections HTR-STA	401				
HTR-ST5	Holders for Square Tubes HTR-ST5	403				
HTR-UNI	Universal Holders HTR-UNI	406				

## Sorted alphabetically

Schmalz – The Company	Type	Designation	Page	Type	Designation	Page
				<b>T</b>		
Vacuum Suction Cups	SEM-C	Compact Ejectors SEM-C	506	TV / TVN	Touch Valves TV / TVN	587
	SEP	Ejector Modules ecoPump SEP	421			
	SGBL-DG	Vacuum Blowers SGBL-DG	535	<b>V</b>		
	SGF	Suction Plates SGF	188	VAGG	Vacuum Unit VAGG	552
	SGM	Magnetic Grippers SGM	248	VAM	Manometers VAM	625
Special Grippers	SGM-HP/-HT	Magnetic Grippers SGM-HP/-HT	252	VAM-D	Manometer VAM-D	628
	SGON	Flat Suction Cups SGON	56	VC-M	Multi-Clamp VC-M	344
	SGPN	Flat Suction Cups SGPN	183	VCBL-B	Clamping Equipment for Biesse consoles	337
	SHF	Suction Plates SHF	131	VCBL-G	Vacuum Blocks VCBL-G	341
	SHFN	Flat Suction Cups SHFN	125	VCBL-GL	Vacuum Blocks VCBL-GL	342
Gripping Systems	SLP	Inline Ejectors SLP	460	VCBL-K1	Clamping Equipment for Schmalz Consoles (single-circuit)	335
	SNG-AP	Needle Grippers SNG-AP	259	VCBL-K2	Clamping Equipment for Schmalz Consoles (two-circuit)	336
	SNG-M	Needle Grippers SNG-M	266	VCBL-R	Clamping Equipment for Grid Tables	339
	SNG-V	Needle Grippers SNG-V	262	VCBL-S	Clamping Equipment for SCM / Morbidelli Consoles	338
Clamping Systems	SNGi-AE	Electric Needle Grippers SNGi-AE	256	VEE	Vacuum End Effectors VEE	328
	SPB1	Bellows Suction Cups SPB1 (1.5 Folds)	139	VF / STF / STF-D	Vacuum Filters VF / STF / STF-D	638
	SPB2	Bellows Suction Cups SPB2 (2.5 Folds)	149	VFI	Inline Filters VFI	644
	SPB2 P	Bellows Suction Cups SPB2 P (2.5 Folds) Flow Restrictor	153	VFT	Vacuum Cup Filters VFT	641
	SPB2f	Bellows Suction Cups SPB2f (2.5 Folds)	165	VOC	Vacuum Operation Center VOC	555
Mounting Elements	SPB4	Bellows Suction Cups SPB4 (4.5 Folds)	156	VOL	Vacuum Reservoirs VOL	533
	SPB4f	Bellows Suction Cups SPB4f (4.5 Folds)	169	VR	Inline Ejectors VR	464
	SPF	Flat Suction Cups SPF	134	VR	Vacuum Regulators VR	623
	SPG	Chocolate Suction Cups SPG	180	VS	Vacuum and Pressure Sensors VS	609
Vacuum Generators	SPI PEEK	Suction Cup Inserts SPI PEEK	228	VS-V-PM/EM-ST	Vacuum Switches VS-V-PM/EM-ST	602
	SPK	Suction Plates SPK	53	VS-V-SA	Vacuum Sensor VS-V-SA	605
	SPL POM-NBR	Suction Plates SPL POM-NBR	217	VS-V-SD	Vacuum Switches VS-V-SD	618
	SPL-HT	Suction Plates for High-Temperature SPL-HT	215	VS-V/P-AH/AV-T	Vacuum and Pressure Switches VS-V/P-AH/AV-T	620
Valve Technology	SPL-HT FPM-F	Suction Plates for High-Temperature SPL-HT FPM-F	212	VS-V/P-W-D-K(-2C)	Vacuum and Pressure Switches VS-V/P-W-D-K(-2C)	614
	SPLO	Suction Plates SPLO	62	VSL	Vacuum / Compressed Air Hoses VSL	649
	SPOB1	Bellows Suction Cups SPOB1 (Oval, 1.5 Folds)	145	VSi	Vacuum and Pressure Switches VSi	611
	SPOB1f	Bellows Suction Cups SPOB1f (Oval, 1.5 Folds)	161	VTR	Vacuum / Compressed Air Distributors VTR	647
Switches and Monitoring	SPU	Suction Plates SPU	48	VZ	Vacuum Centres VZ	534
	SPZ	Vacuum Layer Gripping System SPZ	326			
	SQC	Schmalz Quick-Change SQC	343			
	SSB / SSD	Hose Clamps SSB / SSD	653			
Filters and Connections	SSCB	Suction-Cup Balance SSCB	285			
	SSP	Suction Spiders SSP	327			
	STGG	Thin Glass Grippers STGG	278			
	STV	Screw in Push Fittings	656			
	SU	Suction Cup Covers SU	230			
Services	SVK, SVKG, SVV	Check Valves SVK, SVKG, SVV	578			
	SVN	Check Valves SVN	581			
	SVS-GE	Bulkhead Connectors SVS-GE	399			
Contact	SW	Flow Restrictors SW	584			
	SWGm	Wafer Grippers SWGm	269			
	SXPI/SXMPi	Compact Ejectors X-Pump SXPI / SXMPi with IO-Link	492			

# International Sales Network

On-site Expertise in more than 80 Countries



## GERMANY

(Headquarters)

J. Schmalz GmbH  
Johannes-Schmalz-Str. 1  
72293 Glatten  
T: +49 7443 2403-0  
F: +49 7443 2403-259  
schmalz@schmalz.de

## AUSTRALIA

Millsom Hoists Pty. Ltd.  
A Schmalz Company  
25 Turbo Drive  
Bayswater North VIC 3153  
T: +61 3 9215 8800  
F: +61 3 9720 7879  
schmalz@schmalz.com.au

## CANADA

Schmalz Vacuum Technology Ltd.  
14-2900 Argentia Rd.  
L5N 7X9 Mississauga; Ontario  
T: +1 905 569 9520  
F: +1 905 569 8256  
schmalz@schmalz.ca

## CHINA

Schmalz (Shanghai) Co. Ltd.  
No. 1 Chunquan Road  
201210 Pudong, Shanghai  
T: +86 21 510999 33  
F: +86 21 503988 82  
schmalz@schmalz.net.cn

## FINLAND

Oy Schmalz Ab  
Hakkilankaari 2  
01380 VANTAA  
T: +358 10 2312011  
F: +358 9 85746 94  
schmalz@schmalz.fi

## FRANCE

Schmalz S.A.S.  
Le Prométhée  
65 Avenue du Général de Gaulle  
77420 Champs-sur-Marne  
T: +33 1 6473 1730  
F: +33 1 6006 6371  
schmalz@schmalz.fr

## INDIA

Schmalz India Pvt. Ltd.  
EL - 38 'J' Block MIDC  
Bhosari  
411026 Pune  
T: +91 20 4072 5500  
F: +91 20 4072 5588  
schmalz@schmalz.co.in

## ITALY

Schmalz S.r.l. a Socio Unico  
Via delle Americhe 1  
28100 Novara  
T: +39 0321 621 510  
F: +39 0321 621 714  
schmalz@schmalz.it

## JAPAN

3001-7 Odana-cho  
Tsuzuki-ku  
JP-224-0027 Yokohama  
T: +81 45 565 5150  
F: +81 45 565 5151  
schmalz@schmalz.co.jp

## MEXICO

Schmalz S. de R.L. de C.V.  
Pirineos 500, Bodega 18  
Parque Industrial Benito Juarez  
Micro Parque Santiago II  
76120 Querétaro  
T: +52 442 209 5218  
schmalz@schmalz.com.mx

## NETHERLANDS

Schmalz B.V.  
Generatorstraat 34  
7556 RC Hengelo  
T: +31 74 25557 57  
F: +31 74 25557 58  
schmalz@schmalz.nl

## POLAND

Schmalz Sp.z.o.o.  
Ul. Kobaltowa 4, Zlotniki  
62-002 Suchy Las (Poznan)  
T: +48 22 460 49 72  
F: +48 22 460 49 79  
schmalz@schmalz.pl

## RUSSIA

OOO Schmalz  
Mozhayskoe highway 165, bldg 1  
121596, Moscow  
T: +7 495 96712 48  
F: +7 495 96712 49  
schmalz@schmalz.ru

## SOUTH KOREA

Schmalz Co. Ltd.  
1412 O-Biz Tower  
Beolmal St. 126, Dongan-gu  
Anyang-si, Gyeonggi-do  
T: +82 31 816 2403  
F: +82 31 816 2404  
schmalz@schmalz.co.kr

## SPAIN

Schmalz S.A.  
Avda. Ribera de Axpe. 49  
P.A.E. UDONDO-Edificio B-Nave 2  
48950 Erandio (Vizcaya)  
T: +34 94 480 5585  
F: +34 94 480 7264  
schmalz@schmalz.es

## SWITZERLAND

Schmalz GmbH  
Eigentalsstrasse 1  
8309 Nürens Dorf  
T: +41 44 88875 25  
F: +41 44 88875 29  
schmalz@schmalz.ch

## TURKEY

Schmalz Vakum  
San. ve Tic. Ltd. Şti.  
Aydınlı Mah. Patlayıcı  
Maddeler Yolu  
Dumankaya Botanik A-89  
34953 - TUZLA - ISTANBUL  
T: +90 216 34001 21  
F: +90 216 34001 24  
schmalz@schmalz.com.tr

## UNITED STATES

Schmalz Inc.  
5850 Oak Forest Drive  
Raleigh, NC 27616  
T: +1 919 71308 80  
F: +1 919 71308 83  
schmalz@schmalz.us

You can find the Schmalz sales partner in your country at: [WWW.SCHMALZ.COM/SALESNETWORK](http://WWW.SCHMALZ.COM/SALESNETWORK)

## At Your Service Worldwide

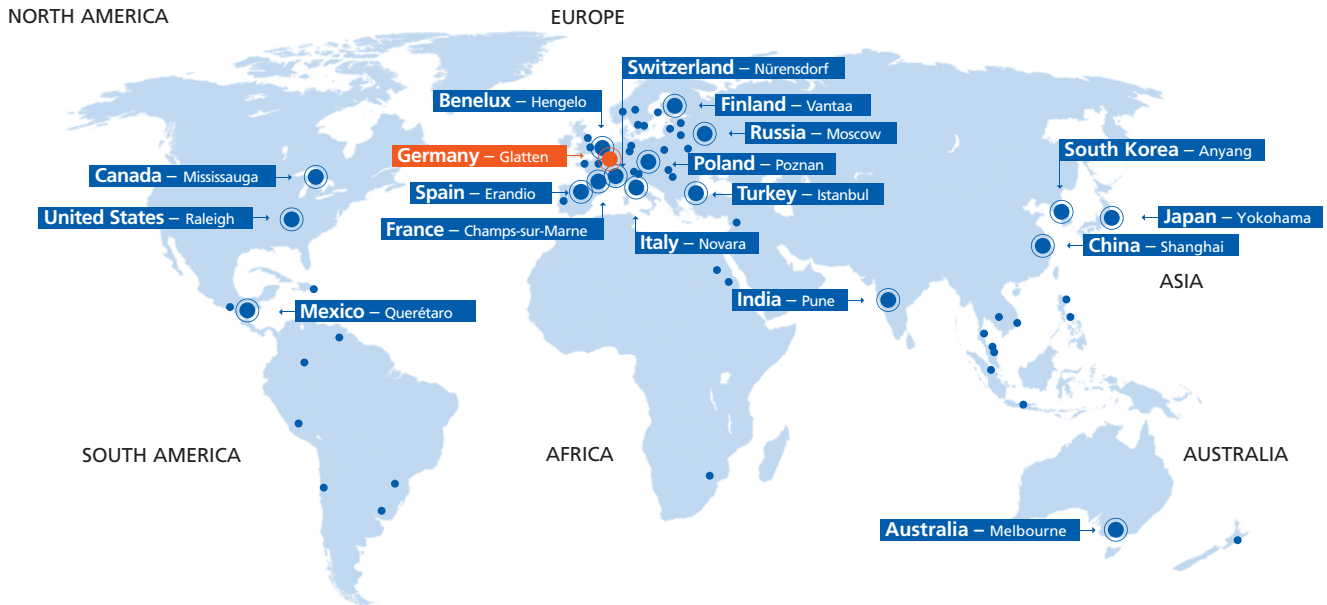

### Headquarters

Schmalz Germany – Glatten

### Subsidiaries

Schmalz Australia – Melbourne  
 Schmalz Benelux – Hengelo (NL)  
 Schmalz Canada – Mississauga  
 Schmalz China – Shanghai  
 Schmalz Finland – Vantaa  
 Schmalz France – Champs-sur-Marne  
 Schmalz India – Pune  
 Schmalz Italy – Novara  
 Schmalz Japan – Yokohama

### Sales Partners

You can find the Schmalz sales partner in your country at:  
[WWW.SCHMALZ.COM/SALESNETWORK](http://WWW.SCHMALZ.COM/SALESNETWORK)

## Vacuum Automation

T: +49 7443 2403-102

## Handling Systems

T: +49 7443 2403-108

J. Schmalz GmbH  
 Johannes-Schmalz-Str. 1  
 72293 Glatten, Germany  
 T: +49 7443 2403-0  
[schmalz@schmalz.de](mailto:schmalz@schmalz.de)  
[WWW.SCHMALZ.COM](http://WWW.SCHMALZ.COM)